

AUSTRALIA'S DYNAMIC ELECTRONICS MONTHLY!

\$2.75*
NZ \$3.50

Electronics Today

INTERNATIONAL

eti

OCTOBER 1985

TWO OSCILLOSCOPES TO WIN!

BONUS: SOLDERING & WIREWRAP SUPPLEMENT

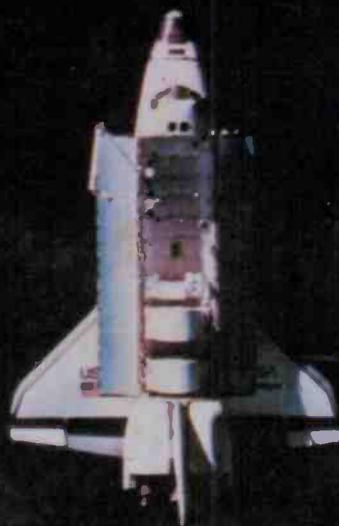

TOURING AUSSAT

**8 mm — THE NEXT VIDEO STANDARD
USING DATA COMMUNICATIONS SERVICES
NO FRILLS AMPLIFIER REVIEWED**

**PROJECTS:
LOW DISTORTION OSCILLATOR
COMPUTER ROUTING SWITCH
OPTICAL CAR ALARM CONTROL**

Get all of Yamaha's latest audio equipment for only 33 cents.



Fill in this coupon and you'll get Yamaha's free catalogue featuring the latest and complete range of compact disc players, cassette decks, turntables, cartridges, integrated amps, separate amps, tuners, receivers, graphic equalizers, headphones and system components. With each component comes something you wouldn't expect. **5 YEAR WARRANTY.**

Name _____

Address _____

Postcode _____

Yamaha Consumer Electronics Division, 17-33
Market Street, South Melbourne, Victoria 3205.

*Limited warranty.



Electronics Today

INTERNATIONAL

EDITOR

David Kelly

EDITORIAL STAFF

Mary Rennie
Jon Fairall B.A.
Robert Irwin B.E.
S. K. Hui B.Sc. (Hons)
Neale Hancock B.E.

DRAUGHTING

David Burrows

ART DIRECTOR

Vicki Jones

ART STAFF

Kevin Miller
Stephen Pickells
Nikki Byrne

ADVERTISING MANAGER

Peter Hayes

ADVERTISING PRODUCTION

Danny Hooper

READER SERVICES

Elizabeth Barnett
Felicity Skinner

ACOUSTICAL CONSULTANTS

Louis Challis and Associates

MANAGING EDITOR

Jamieson Rowe

PUBLISHER

Michael Hannan

HEAD OFFICE

140 Joynton Avenue, (PO Box 227)
Waterloo, NSW 2017.
Phone: (02) 663-9999 Sydney.
Telex: 74488, FEDPUB.
Federal Facsimile: 663-5144.

**ADVERTISING OFFICES
AND AGENTS:**

New South Wales: Peter Kilby, The Federal
Publishing Company, 140 Joynton Avenue,
Waterloo.

Victoria and Tasmania: Virginia Salmon, The
Federal Publishing Company, 23rd Floor, 150
Lonsdale Street, Melbourne, Vic. 3000. Phone: (03)
662-1222 Melbourne. Telex: 34340, FEDPUB.

South Australia and Northern Territory: Steve
Birbeck, The Admedia Group, 24 Kensington
Road, Rose Park, SA 5067. Phone: (08) 332-8144
Adelaide. Telex: 82182, ADMEDIA.

Queensland: John Perry, The Federal Publishing
Company, 25 Balaclava Street, Woolloongabba,
Qld. 4102. Phone: (07) 391-8922. Telex:
AA145520.

Western Australia: Tony Allen & Associates, 7
Fore St, Perth, WA 6000. Phone: (09) 328-9833.

New Zealand: Chris Horsley, 4A Symonds Court,
Symonds Street, Auckland. Telex: NZ60753,
TEXTURE. Phone: 39-6096. Auckland.

Britain: Peter Holloway, John Fairfax and Sons
(Australia) Ltd, Associated Press House, 12
Norwich Street, London EC4A 1BH. Phone: (01)
353-9321 London. Telex: 262836, SMHLDN.

Japan: Genzo Uchida, Bancho Media Services,
5th Floor, Dal-ichi Nisawa Building, 3-1 Kanda
Tacho 2-chome, Chiyoda-ku, Tokyo 101. Phone:
(03) 252-2721 Tokyo. Telex: 25472, BMSINC.



ELECTRONICS TODAY INTERNATIONAL is published monthly by the Electronics Division of the Federal Publishing Company Pty Limited, 140 Joynton Avenue, Waterloo, NSW 2017 under licence from Double Bay Newspapers Pty Limited, General Newspapers Pty Limited and Suburban Publications Pty Limited. Typeset by ESN-The Litho Centre, Sydney. Printed by Masterprint Pty Ltd, Dubbo NSW. Distributed by Gordon and Golch Limited, Sydney. *Maximum and recommended Australian retail price only. Registered by Australia Post, Publication No NBP0407. ISSN No 0013-5216.

COPYRIGHT © 1985, Double Bay Newspapers Pty Limited, General Newspapers Pty Limited and Suburban Publications Pty Limited (trading as "Eastern Suburbs Newspapers").

FEATURES

The bird's eye view	10
8 mm video is set to soar high	
Audio best at Perth CES	16
Blue ribbons still going to CD	
Data communications	20
The search for the ultimate transmission	
Starting electronics	92
Making the right connection	
Touring Aussat	114
Tripping around the Californian plant	

PROJECTS

ETI-169: Low distortion audio oscillator	54
ETI-665: Computer routing switch	63
ETI-343: Optical car alarm switch Part 2	70

REVIEWS

The 8 mm video challenge	29
Sony's Video 8 model CCD-V8 has thrown down the gauntlet	
Top sound, budget price	36
Yamaha has dropped the 'fancy overheads' on its A-320	
Well staged performance	88
Eclipse ECS-186 computer comes assembled or in kit stages	
Good things come in small packages?	108
Marketing principles and performance sometimes diverge	
Affordable hobbyist's CRO	119
Assessing the Dick Smith bargain	

OFFERS

Reader information service	19
ETI mail order books	103,105,106
Subscriptions offer	107
Dick Smith CRO competition	118

DEPARTMENTS

News Digest	6	Ideas for Experimenters	81
New Equipment	48	Microbee Column	85
New Components	52	Shoparound	98
Computing News	82	Minimart	98
Communications News	100	Dregs	122
Idea of the Month	80		

COVER: Photographs courtesy of ATN-7 Sydney and NASA.

SCOPE SPECIALISED TOOLS

PORTABLE SOLDERING STATION

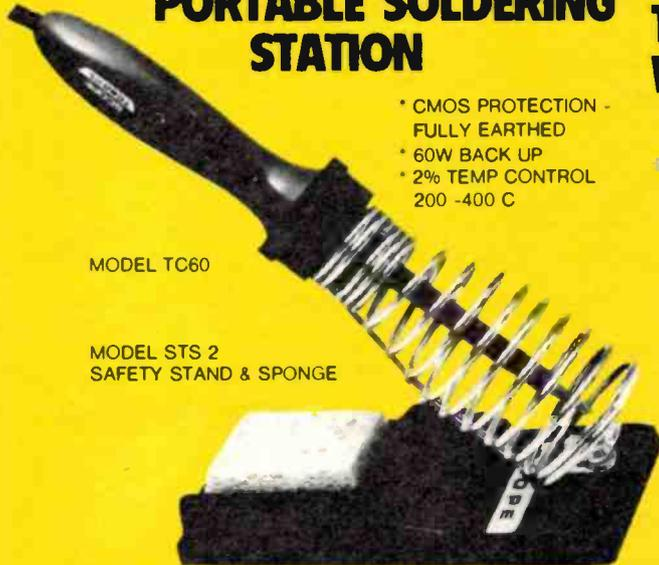

MODEL TC60

MODEL STS 2
SAFETY STAND & SPONGE

- * CMOS PROTECTION - FULLY EARTHED
- * 60W BACK UP
- * 2% TEMP CONTROL 200 - 400 C

THE PENCIL IRON WITH REAL POWER



- * YOUR FINGER ADJUSTS WATTAGE & TEMP. 200 - 500 C
- * FAST HEAT FOR MAINTENANCE & REPAIR WORK

MANUAL
ADJUSTMENT OF
TEMPERATURE
200 - 500 C

INDEXING P.C.B. HOLDER

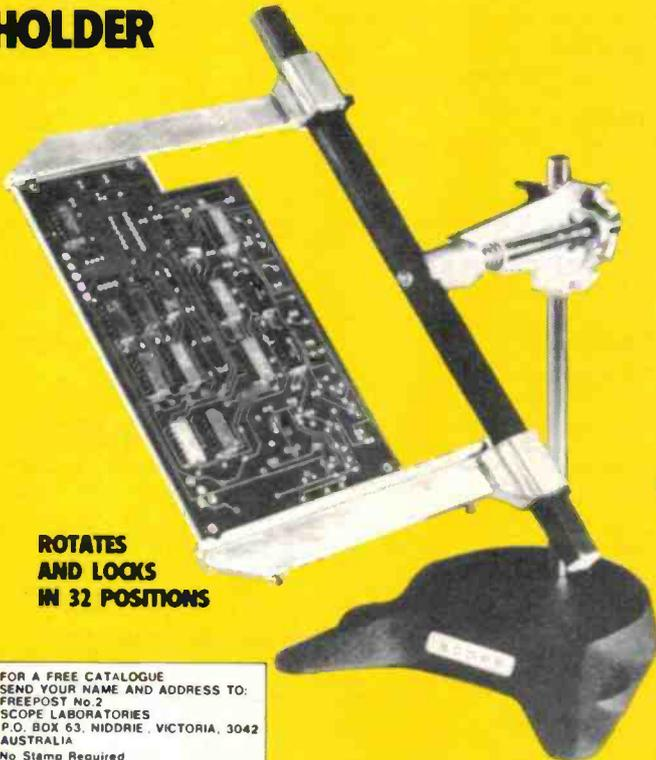

ROTATES
AND LOCKS
IN 32 POSITIONS

SELF CLEAN TIP METAL BODY

- * CRUSH PROOF METAL BODY
- * TIP SELF CLEANS EVERY CYCLE



RADICAL SCISSOR ACTION



- * SAFETY OFFCUT CATCHER OPTION
- * SCISSOR ACTION REDUCES CUTTING EFFORT

FOR A FREE CATALOGUE
SEND YOUR NAME AND ADDRESS TO:
FREEPOST NO 2
SCOPE LABORATORIES
P.O. BOX 63, NIDDRIE, VICTORIA, 3042
AUSTRALIA
No Stamp Required

CONTACT
YOUR NEAREST
SCOPE RETAILER

N.S.W.
Promark (02) 439 6477
Selectro Parts (02) 708 3244
D.J. Coulter (049) 67 1455 AA 28650
Geo Brown (02) 519 5855
Sheridan (02) 699 6912
Martin De Launay Pty Ltd (02) 267 1055 AA26679
David Reid (02) 267 1385

QLD.
L E Boughen (07) 369 1277
ECO (07) 376 5677
Fred Hoe (07) 277 4311
Delsound (07) 229 6155
Dunlop IBC (07) 392 0011 AA41561
St Lucia Electronics (07) 52 7466 AA42883
Magraths (07) 832 3944

VIC.
Aust School of Electronics (03) 523 5622
Ballarat Electronics Supplies (053) 31 1947 AA37435
Ellistronics Pty Ltd (03) 561 5844 (03) 602 3282
Radio Parts (03) 329 7888 (03) 211 8122 (060) 21 8177
Teleparts Investments Pty Ltd (052) 21-7288
McGraths Electronics (03) 347 1122 AA31001
R D Irving (03) 489 8131
Electroool (03) 848 1045

S.A.
AJF Electrical (08) 269 1244
Gerard & Goodman Pty Ltd (08) 223 2222 AA 88983

W.A.
Atkins Carlyle Ltd (09) 321 0101 AA93750
Letco Trading Company (09) 387 4966 AA94396

TAS.
GHE Electronics (002) 34 2233 (003) 31 6533



SCOPE

(03) 338 1566
TLX 38318

SERVICES

TECHNICAL INQUIRIES: Technical inquiries by mail must be accompanied by a stamped self-addressed envelope. There is no charge, but we reserve the right to publish the inquiry and the reply in *Electronics Today* or any of its associated publications. We can only answer queries relating to projects and articles as published. We cannot advise on modifications, other than errata or addenda. Difficult questions may take some time to answer.

GENERAL INQUIRIES: For all inquiries about back issues, subscriptions, photocopies of articles, artwork or submitting articles, call (02) 663-9999 or write to: ETI Reader Services, 140 Joynton Avenue (PO Box 227), Waterloo, NSW 2017.

CONTRIBUTIONS: Submissions must be accompanied by a stamped, self-addressed envelope. The publisher accepts no responsibility for unsolicited material.

COPYRIGHT: The contents of *Electronics Today International* and associated publications is fully protected by the Commonwealth Copyright Act (1968). Copyright extends to all written material, photographs, drawings, circuit diagrams and printed-circuit boards. Although any form of reproduction is a breach of copyright, we are not concerned about individuals constructing projects for their own private use, nor by bands (for example) constructing one or more items for use in connection with their performances. Commercial organisations should note that no project or part project described in *Electronics Today International* or associated publications may be offered for sale, or sold in substantially or fully assembled form, unless a licence has been specifically obtained so to do from the publisher, The Federal Publishing Company, or from the copyright holders.

LIABILITY: Comments and test results on equipment reviewed refer to the particular item submitted for review and may not necessarily pertain to other units of the same make or model number. Whilst every effort has been made to ensure that all constructional projects referred to in this edition will operate as indicated efficiently and properly and that all necessary components to manufacture the same will be available, no responsibility is accepted in respect of the failure for any reason at all of the project to operate effectively or at all whether due to any fault in design or otherwise and no responsibility is accepted for the failure to obtain any component parts in respect of any such project. Further, no responsibility is accepted in respect of any injury or damage caused by any fault in the design of any such project as aforesaid.

I HAVE NOW SEEN Australia's domestic satellite go from inception to birth since the time I started editing electronics magazines. In the late seventies there was a lot of discussion in the electronics community about a number of 'brave new' communications technologies like Prestel (now called Viatel), cable television, subscription television, fibre optics and direct broadcast satellites.

It was in this optimistic environment, with the aid of a little political "pork-barrelling", that Aussat was conceived. The decisions of that time mean that the satellite will never be quite as suitable or viable as it could have been.

The cynics have called the satellite Australia's highest flying pork-barrel. You can't even blame a particular political party as Communications Ministers from three parties had a hand in flogging the satellite idea.

When it was first decided that we'd have a satellite, there weren't many examples to go by. Only Indonesia and Canada had similar satellites going and for some reason we chose the Canadian one as an example.

Canada's first satellite was highly experimental and impressed just about everyone with demonstrations of direct television broadcasting. The Canadians and Hughes Aircraft were so keen they moved a Canadian satellite over Australia for a demonstration. A sacrificial gesture it seems as the satellite ran out of station keeping fuel and failed after the demonstration.

The effort worked because we did in fact buy a Hughes satellite, but the Canadian experiment may not have been the best guide for Australia. Canada, near the North Pole, is not a large but a small country from a satellite's point of view and a good target for satellite broadcasting.

Australia's satellite was designed mainly as a direct broadcasting system. Some general communications ability was added at the instigation of a conservative government, both to help pay for the satellite and to provide some competition for Telecom. Ironically the Telecom strikes of the time probably led to an expansion of the satellites general communications ability.

In the end, half the satellite's electrical power, its most limited resource, is dedicated to broadcasting. Yet most of the discussion since we decided to buy the satellite system has been aimed at limiting the use of these broadcasting transponders lest they compete with terrestrial broadcasters.

At the very last chance Aussat decided to reduce the satellite's operational life by adding switches which would find other uses for the high power broadcast transponders.

Now we have the satellite. Let's hope we find it useful and it will pay its way despite all the limitations we have imposed on it.

David Kelly
Editor

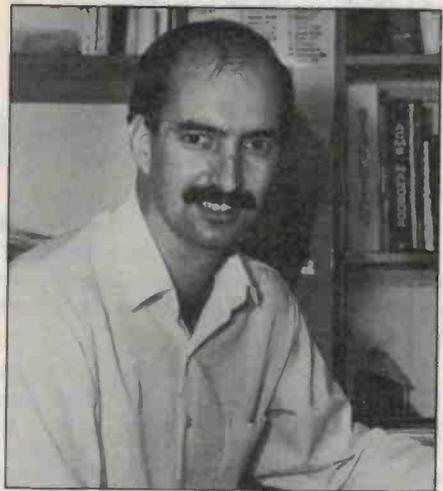

AUSSAT LAUNCH

Covering the launch of Aussat. Our peripatetic, night owl journo answers questions: who splashed everyone with champagne? And why did the Yanks try to stick a post up our antenna? These riddles and more will be answered next month.

JOINING THE CLUB

Aussat joins at least 33 other satellites all broadcasting signals more than 10 degrees above the Australian horizon: a sky full of telly! What possibility is there of you receiving them?

ROBOT TO BUILD

Advance Australian robots! Our office robot can pace from one end of the room to the other and pirouette in the middle! So far the tea lady's job is safe but we haven't begun to wear out this programmable, navigating robot.

NEXT MONTH

LIGHT BULB SAVER

This project has been held over to next month despite our rash promises. In the effort to bring you a highly reliable project — and for our own curiosity — testing ran a bit longer than we expected. Next month will see the anticipated article.

1200/75 BAUD MODEM

ETI has been very successful in designing modems. In fact, we are the leading Australian electronics magazine in this area. Due to the huge recent demand for the Viatel 1200/75 modem, ETI will knock out a WORLD BEATING design in the December Issue.

'Cellular' mobile phones to start next year

Telecom will offer a new high capacity mobile telephone service, using a network technique called cellular radio. When the service starts in Sydney late next year Australia will be one of a handful of countries in the world using the cellular technique.

Telecom has signed a contract with telecommunications supplier LM Ericsson worth nearly \$16 million for the initial equipment needs of the system and will spend around \$65 million on the service in its first three years.

While this seems a lot of money to spend on a new mobile phone service, the revolutionary cellular technique promises to squeeze many thousands more subscribers into few frequencies.

The existing mobile phone service will soon be used to capacity. With it the use of one frequency by a subscriber prevents that frequency's use by any other subscriber within the same city at that time.

Cellular radio divides a city into many small cells, some only a few kilometres across. Frequencies can be re-used many times so long as they are not re-used in adjacent cells.

Because many subscribers can use the same frequency at the same time but in different parts of the city, cellular radio drastically increases the number of mobile telephones that can be connected to the service.

Each mobile phone on the service will have two receivers and two transmitters. While one transceiver pair is used in a conversation the other pair continually looks for another base station to give a better signal.

The system has a high immunity to fading because mobiles are always close to base stations and always have a number of base stations to choose from. The continual frequency changes also provide considerable protection from eavesdropping.

The Minister for Communications, Michael Duffy said, "Besides providing a reliable means of mobile telephone communications, the introduction of cellular radio will provide an important boost to the local electronics manufacturing sector, as nearly half of this first contract involves local content."

"While Telecom will be the sole operator of the network, and will also provide the infrastructure, private enterprise will be able to manufacture and sell the customer units (car units, portable and hand-held units) in competition with Telecom. A

minimum level of local content will be required for these units."

Mr Duffy said the first cellular network was expected to begin in Sydney in late 1986, with Melbourne and other capital cities following in 1987. Telecom had estimated that 100,000-150,000 mobile and portable telephone services would be in operation by 1994.

The present automatic mobile telephone system will be compatible with the new system and would continue to operate alongside it in the capital cities. To serve regional and more remote areas Telecom is planning an interim non-cellular mobile service employing manual operators. The equipment for this service would be manufactured in Australia. The first of these services is scheduled to begin late this year.



From left, Part of the UNSW VLSI CAD research team, Foo Ngok Yong, Tony Ng, David Gedye, Dr Graham Hellestrand.

Oz CAD tools

Australian home produced CAD tools for integrated circuit design are finally looking successful after three years of dedicated research conducted at the University of New South Wales (headed by Dr G. Hellestrand) and RMIT (headed by Dr G. Egan). A specially formed company called Neology has been granted the contract to commercialise the work. In the very near future, these tools will allow a great number of Australian companies to design and simulate custom chips in their own environments.

Not only will manufacturers be able to protect their products against cheap copies with custom chips, they will be able to supply our demands in high technology products too. According to university and company representatives, in the last twelve months Australia has spent more than \$3 billion on

imported high technology equipment, but produced just over \$4 million worth of components. Many of the imports contained silicon chips and printed circuit boards which could have been produced locally. This huge market for electronics within Australia will be self supporting only if CAD design tools are widely used throughout industry and Australian companies begin designing chips to supply our own market.

With the support of the Department of Science, Technology and Commerce, these integrated circuit design software tools are now being commercialised under a contract worth \$700,000. The money will be reinvested by UNSW and RMIT into more research. Currently, UNSW is concentrating on very large scale integration (VLSI) tools and RMIT on standard cell and gate array tools.

Semi-custom linear ICs

The semi-custom and custom IC design and fabrication techniques that have been available to digital designers for some time are now being applied to linear circuits.

David Spalding Pty Ltd, known for its research into ultra high speed digitisers, and the Canadian semiconductor house

Linear Technology Inc have combined to set up a new linear IC design bureau.

Information on this new design and prototyping service is available from David Spalding Pty Ltd, 45A Blakett Drive, Castle Hill, NSW 2145. F. Perot & Co will continue to represent LIT's full standard product line.

Electronic shopping

With the growing trend towards electronic shopping via home computers, Dick Smith Electronics has expanded its input to the Viatel service from 20 to 250 pages.

The on-line service through Cable Shop means that people can call up the DSE catalogue on a home computer or Video-text terminal and make purchases through a Bankcard or credit card.

Viatel is an inexpensive infor-

mation and trading service through the phone lines. By hooking a computer to the Viatel service, users immediately have pages of information at their disposal. Both shopping and banking can be conducted through the service.

Dick Smith Electronics will also present specials, data and information for enthusiasts. There's no charge to call up these pages, and the goods will be forwarded the next day.

New CSIRO technique saves \$21m

The Minister for Science, Mr Barry Jones, has announced that an estimated \$21 million and 10 years of effort have been saved in mapping the Great Barrier Reef by a CSIRO-developed technique of using data from the American Landsat series of satellites.

The technique, officially called the Barrier Reef Image Analysis System but nicknamed 'BRIAN', was developed for the Great Barrier Reef Marine Park Authority by Dr David Jupp of the CSIRO's Division of Water and Land Resources in Canberra. It enables rapid and inexpensive mapping of shallow marine areas on a very large scale and has enormous significance for the Authority's activities of classifying, monitoring and protecting the Reef, and for mapping islands and shallow water areas throughout the Pacific and ASEAN regions.

A successful pilot project has already been completed in Papua New Guinea and interest in the technique has been shown by government authorities in In-

donesia, the Philippines, Malaysia, Thailand, the Republic of the Maldives, Fiji and the Solomon Islands. A 'MICRO-BRIAN' program has now been developed for use on a micro-computer and will increase its usefulness in developing countries.

The technique was initially developed to map sea depth and interpret marine resources in shallow waters in particular Reef areas. However, the Authority realised that BRIAN could also be used for large-area mapping of the entire region at international cartographic standards of accuracy at 1:250,000 scale. Once this potential was accepted, the Authority played a major part in transferring BRIAN to the Australian Survey Office.

All the work necessary for production of maps covering the entire 348,000 square kilometre Great Barrier Reef region has now been completed by the ASO at an approximate cost of \$250,000.

BRIEFS

Music group

Noise Inc, a Ballarat-based volunteer group with experience in the electronics and music industries, is offering young people the opportunity to practise music using the group's equipment and expertise. Training in the construction and operation of pa equipment is also available. For further information, phone (053)31-7493.

In-flight video games

Singapore Airlines has introduced a range of computer video 'brain games'. The new entertainment system enables passengers to independently operate a console containing audio-visual systems capable of delivering video games, electronic card and table top games from their seats. The airline will progressively equip its entire B747 fleet with the system. Charges are around \$US2 per hour and the consoles accept credit cards.

Robot 'eyes' system

Vision Systems, an Adelaide-based company formed only two years ago, has been chosen to commercialise a high-speed vision processor developed by the CSIRO. A prototype of the system will be demonstrated this month, when Vision Systems moves into a purpose-built facility in Adelaide's Technology Park. Claimed to be 100 times faster than nearest rivals, the system's capabilities for picking out faulty products on production lines extends even to the grading of rice and wheat. It will be in full production by February 1986.

Bicentennial link

Telecom has awarded contracts worth \$20 million for its first intercapital optical fibre link, between Sydney and Melbourne, planned to go into service on Australia Day 1988. It will have a capacity equal to 60,000 simultaneous speech circuits. All cable and just over half the transmission equipment will be made in Australia.

Aussie robots step out

Tasmanian high-tech robotics company, Branch & Associates, is attracting US interest in its autonomous vehicle navigation technology. Branch claims to have initiated new contracts and joint venture agreements potentially worth \$34 million over the next three years and involving some 47 new jobs.

Superchips getting hot

The next generation of integrated circuits is looming on the horizon, and ought to be visible pretty soon. Hard on the heels of IBM's announcement that it has a one meg memory chip in prototype form, Siemens and Toshiba have also come to the party with a joint venture to produce a one meg chip, with a view to development of a 4 meg chip by 1989. Siemens hopes to have the one meg chip in production in 1986, and recently announced that its R&D budget would increase to Dm 1.7 x 10⁹. Philips of the Netherlands also has a stake in the project.

Meanwhile the American

military is pumping money into the VHSIC project. VHSIC (pronounced Vis-ik) is an acronym for Very High Speed Integrated Circuits. Government money to the developers should exceed \$US1 billion by 1990.

The project has two phases. One is to produce chips with clock rates in excess of 25 MHz. The second is to increase this to 100 MHz. Speed is limited essentially by the time delay imposed by the size of the elements within the chip. Phase one requires components on the chip substrate to be about 1.25 µm, while phase two will require half micron technology.

NOTES & ERRATA

Series 5000, Stereo Control Preamp/ifier, October '81: Just to prove that we do care, ETI staffers often (sometimes) build up projects for their own edification. One of us recently decided to build the series 5000 preamplifier, and spent a frustrating day trying to set up the level meters using the on-board oscillator. (Does this sound familiar?) Turns out the overlay, printed p 38 October 1981, shows R53 and R52 as 220 ohm. The circuit diagram and the parts list show 220k, which is the correct value. This mistake does amazing things to the input resistance of the line amplifier. The moral of the story: check parts lists, circuit diagrams and overlays for inconsistencies. We try to be perfect, but even angels slip up sometimes.

Project 153, Temperature Adaptor for DMMs, June '83: A note at the end of the parts list says that a 5V6, 1 W zener can be substituted for the original. This should actually read 5V1, 1 W.

Ideas for experimenters, Motor car light controller, April '85: Peter Hill's idea for a motor car light controller (ETI 1985) was drawn with Q1 and Q2 as npn transistors. In fact they are pnp's. Our apologies.

ETI new faces



Neale Hancock

We have just got ourselves a new engineer whose ingenuity and creativity are exceeded only by his beauty. Born in England 1961, he was educated at Geelong, which is somewhere between ci-

vilisation and the South Pole, and later in the hallowed halls of RMIT, where vicious dons thrashed knowledge into young Neale at a prodigious rate. He now knows all the colour codes on resistors right up to nine. Seminal educational experience had with Gaylene \$\$\$\$ behind smoko shed at Whitley college, University of Melbourne. Fave muso: Peter Gabriel. Fave saying: "Up yours Rambo" (in a quiet voice and only when the big R is not in the room). Described as having "wild life style". Spends his money on a recording studio. "It's either that or become a Yuppie." Likes Mex food and tequila. He once worked for the Department of Aviation in a somewhat junior capacity. Now described as a learning experience. Don't worry about the picture. We know it's not very flattering but he only looks good when he's drunk.



With a Barra Sonobuoy are chairman of AWA Mr J. A. L. Hooke, Defence Minister Kim Beasley, and general manager of AWA North Ryde Division Mr Graham Darley.

More Barrabuoyes

AWA has signed its fourth major contract for Barra sonabuoyes with the Department of Defence.

The sonabuoy has been in

production since 1979, and is used by the RAAF and RAF for submarine detection. The total contracts have been worth about \$100m.

No more crossbars

There was a celebration at Meadowbank the other day as Plessey staff celebrated the roll out of the last crossbar switch. Plessey has been manufacturing crossbars for Telecom exchanges for the last 25 years, and these switches now form a central component in most Telecom exchanges.

Production reached a peak in the 1970s, when the plant was responsible for a significant percentage of employment in the Meadowbank area. Production then was 12 a day. Over the full time of the contract more than 16,000 have been produced.

CSIRO leads Australian industry into space

Australian companies have won space technology contracts worth \$20 million in a major step towards developing an Australian space industry.

The Minister for Industry, Technology and Commerce, Senator John Button, and the Minister for Science, Barry Jones, jointly announced the biggest of three contracts — a \$15 million deal with the CSIRO for the construction of antennas for the Australia Telescope.

The two smaller contracts were announced recently by OTC. One is for the construction and design of three OTC earth station antennas, the other for the development of an Intelsat rooftop earth station proto-

type specially designed for Australian conditions.

The ministers also announced that the CSIRO and Australian company Macdonald Wagner were moving towards the formation of a joint venture company to market Australian antenna designs on the international market, particularly in the Asian and Pacific regions. The company is expected to be set up before the end of the year.

The CSIRO has awarded the Australia Telescope antenna contract to the Brisbane-based company, Evans Deakin Industries Ltd. The 18-metre diameter OTC station antennas will be designed by Macdonald Wagner in consultation with CSIRO's

Division of Radiophysics, and will be built by Johns Perry Ltd of South Australia. The remaining \$2.5 million OTC contract to develop rooftop earth stations for the Intelsat Business Services network has been awarded to a consortium, headed by Codan Pty Ltd of Adelaide and comprising CSIRO's Division of Radiophysics, the University of Sydney, the South Australian Institute of Technology and MITEC Pty Ltd (University of Queensland).

By the end of 1985 Australia will have spent about \$500 million on operational space systems such as Intelsat and Ausat, but relatively little of the equipment associated with these

systems has been manufactured in Australia. The new contracts should go a long way towards changing this situation and are the result of cooperation between government bodies, universities and industry.

The announcement of the space technology contracts follows the release of the Madigan report, "A Space Policy for Australia". The report urged the development of a space industry and identified small and medium-sized ground receiving stations as providing the best opportunities for Australian industry.



You can come on an incredible journey, not to the future, but to a technology available today for innovative electronics users. Philips, custom design and manufacture right here in Australia, both hybrid circuits or custom I.C. chips, to suit your budget and product concept.

Access to reliable hi-technology at very competitive cost even in modest production quantities.

Tell the Philips Elcoma designers what you are trying to achieve and they will create for you a unique microcircuit solution. Perhaps you already have a design. That's where Philips 50 years of continuous production experience in Australia will ensure an efficient result. Naturally, your product design security is always assured and the resulting microcircuit is exclusively your own property.

Philips years of practical experience in computer aided design (CAD/CAM) will get you off to a good start. Your new electronics package will require little space, will improve reliability and the performance of your "new product." At the same time it will provide you with more features and added benefits for your customer, and protect your design against "copycats"!

Imagine the new business opportunities with Philips custom microcircuits

The time it takes, from engineers briefing to delivery of your first electronic microcircuit or micro sub-assembly, will pleasantly surprise you. Design sampling and testing may be as little as 8 to 10 weeks for hybrid circuits. More advanced custom "monolithic chip" designs will take longer, depending on the size of the chip and complexity of the design.

Send off the coupon today or call Philips Electronic Components & Materials to get the ball rolling on the improvements you'd like to make to your product.

Sydney	(02) 439 3322
Melbourne	(03) 542 3333
Adelaide	(08) 243 0155
Perth	(09) 277 4199
Brisbane	(07) 44 0191

We make electronics in Australia

I'd like to explore the benefits of Philips microcircuits in my products. ETI

My area of interest is _____

Name: _____

Organisation: _____

Address: _____

Postcode: _____ Phone: _____

Send to: Philips Elcoma, 11 Waltham Street, ARTARMON, N.S.W. 2064.

THE UNTOB



Electronic Components & Materials

PHILIPS

THE BIRD'S EYE VIEW

— 8 mm video

Jon Fairall

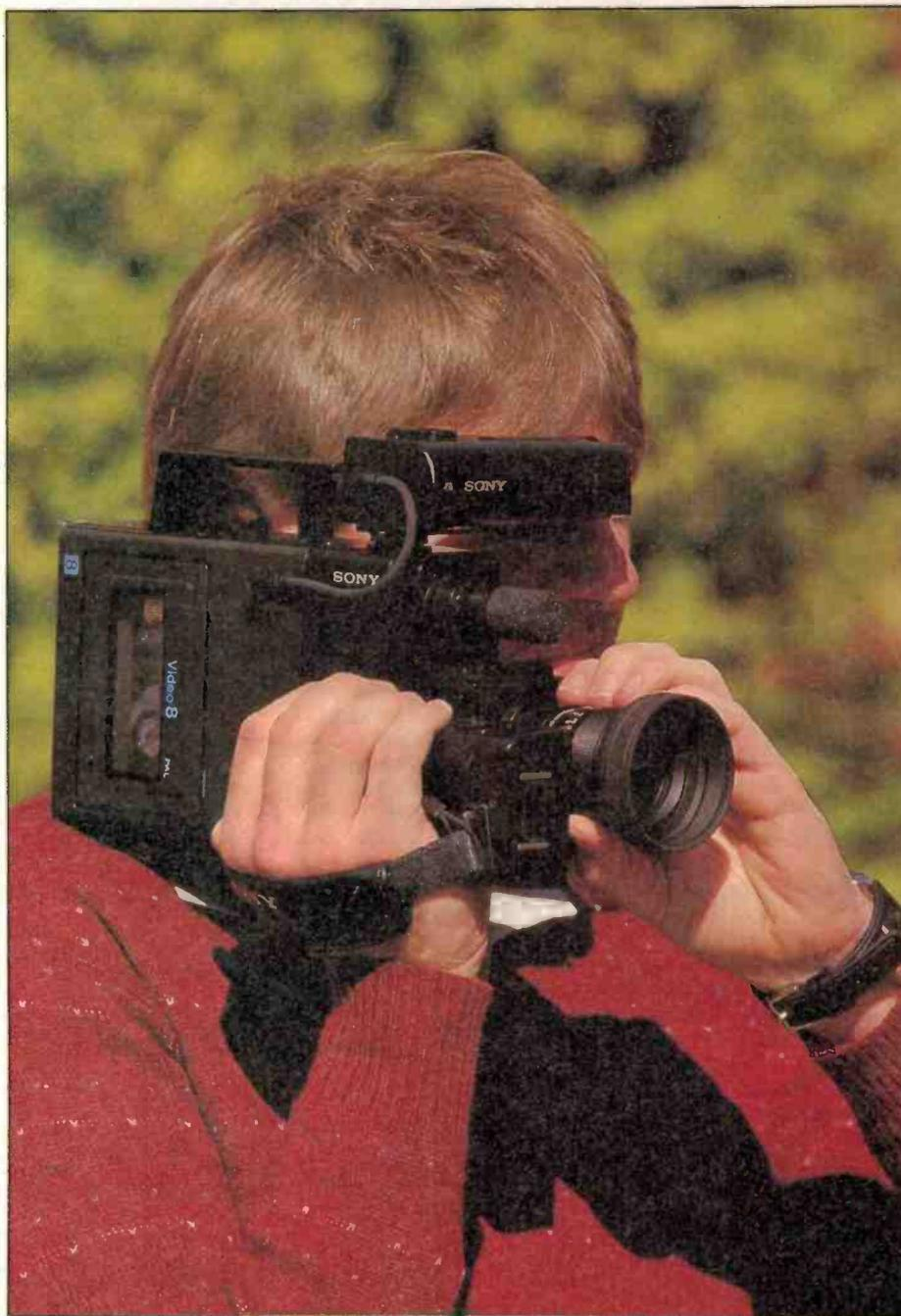

Video packages are getting lighter and flying higher. The latest release, 8 mm video, has miniaturised all that 'state of the art' into something like an eyewitness shoulder bag! Playback could hardly be easier. So how do they do it?

SONY RELEASED its first 8 mm product in Sydney on July 17. It was a fairly low key affair, nothing much appeared in the general media. And really, it was to be expected. The package looks innocuous, and no amount of talking the market up can change that.

All of which shows how wrong appearances can be. The 8 mm video is probably the most sophisticated product ever to be released on to the domestic market. It represents a degree of circuit integration only dreamed of 10 years ago, light reception capability as good, if not better, than most professional cameras costing orders of magnitude more, and extremely high level tape technology.

All the planned or released 8 mm products follow a similar pattern. At the heart of the system: a camcorder — a camera and recorder in one package. Then some kind of additional module that carries, at a minimum, provision for modulating the camera output so that it can be received by a TV. This module will also have a separate tuner/timer element to allow the unit to function like a traditional Beta or VHS VCR. The difference between this system and the older ones is that it uses a tape package system no bigger than a typical audio cassette tape.

Truth to tell, 8 mm technology is not new. In fact this magazine recorded in a 1981 edition the release of an 8 mm prototype in Japan. Between then and now has been a long hard slog for both the 8 mm format and the Sony company, whose baby this is. During that time the Japanese giant has had to accept that all its

THE USER'S VIEW

Sony gave us one of its precious demonstration models, the Video 8 model CCD-V8, to have a look at while I was researching this article, and, rather than have it clutter up the office, I took it home for the weekend. Just to prove that ETI is on duty 24 hours a day and weekends, here is a little essay entitled "What I did on the weekend".

It's easy to be blinded by the spectacular technology into a totally uncritical attitude when talking about 8 mm video. In fact, there is considerable room for improvement from the user's point of view. Having said that, it needs to be stressed that 8 mm video is orders of magnitude better than anything else on the market when it comes to making home movies.

Another plus: it's really easy to use, evidenced by the fact that somewhere along the line the manuals had parted company with the package so I had to use common sense alone to figure out how to shoot.

First impressions: it's ultra light. I remember in a former life being required to hump professional movie or video gear around the place. You needed a Real Man for the job and I'm afraid my muscles weren't up to it so they replaced me with a gorilla from the dole office. I've been sensitive about my stature ever since. Anyway, you can carry a Video 8 around for hours without problems. Even those of you who are small and petite and rather cute.

Second impression: the handgrip is really nice. It's designed to be held with the right hand, stabilised against the shoulder. In this position you have perfect control, and the eyepiece is right in front of your eye. It's easy to move, easy to hold steady. The left hand is completely free to manipulate the focus and zoom controls.

The only problem is that there is little room for adjustment. A lady who tried it (and has small, petite and rather cute hands) found it difficult to get at the record button while still supporting the weight of the machine. Conversely, a local gorilla complained that the strap was too tight and I had to take it off him before he ate it. But both parties agreed that they could get used to it.

The view through the eyepiece requires 'interpretation'. It's a one inch black and white screen with a magnifying glass in front of it. The magnifying

glass is both removable and adjustable, so you can view it without the glass if required or adjust the degree of magnification to suit your eyes. I found that viewing with the glass removed was ideal for playback on location, especially if someone else was peering into it at the same time.

Actually filming with the magnifying glass in place took a bit more getting used to. The adjustment moves very easily, so one is never quite sure whether lack of focus is due to faulty magnification of the image or faulty setting of the camera. There are other problems. The image is so small one tends to overlook small objects in the field. It is incredibly 'contrasty', so any dark area appears as a black blob, and you can't see anything happening in it. I also found the image tended to blur easily during even the most modest pan. Most of these features tend to disappear during a playback into a TV set or monitor, so they are artefacts of the display rather than the imaging system, but nevertheless they take some getting used to.

As a matter of fact the whole idea of using a black and white monitor for the eyepiece seems a little questionable to me. What's wrong with a TTL optical system similar to that used in 35 mm cameras for years? I concede a more complex optical system but I would have thought the advantages worth it.

The first recording I did was to take some shots of people sitting around at home. It was night time and the scene was lit by 60 watt incandescent bulbs. I was not particularly surprised when they turned out on playback to be a yucky shade of green. Disappointed, but not surprised. The Sony claim is to be able to shoot down to 20 lux, which should allow shooting under candle light, so I was hoping for better performance than from my 8 mm movie camera equipped with fast film.

The problem was solved when I started fiddling with a little switch on the side called 'white balance'. A perusal of the manual would have shown me that this has to be operated before shooting every scene to allow the camera to set up the colour correctly for the particular illumination levels present. I would really have liked to see this function automated, because it was the

only one that caused me any problems at all. Considering the other technical marvels achieved in the CCD 8 this should be small beer.

Having got the operations sorted out I started playing about with it, first indoors, and then on an expedition to the Sydney Boat Show, which was being held on one of the piers down in the harbour. Playback was little short of spectacular, especially images shot outdoors with the sun shining. It seemed slightly better than the best off-air images I can receive on my set (UHF aerial, two baluns, about fifty foot of coax cable), considerably better than the best half-inch tape I have ever seen played back at home. One interesting thing I noticed: the virtual total absence of 'comet tails', the long, slowly fading streak that used to crop up on video systems whenever a bright light crossed the screen.

The only thing that concerned me during our little expedition was that the camera suddenly seemed a little less than robust. There is a big lens hood that covers the whole lens and microphone assembly. It's made out of very flimsy plastic and would presumably last not a long time in actual practice. The eyepiece is also cause for concern, as in normal operation it projects out at right angles from the camera body. How long would it last on the family holiday I wonder. A special carry case is available from Sony as an optional extra. It's worth it, unless you are the super careful type. I think the Sony people would do their reputation a favour if they included it in the basic deal.

The sound system is a little gem. The microphone is reasonably directional, and picks up pretty much what you want, without lots of background noise. I suspect that's due as much as anything to the fact that a filter is used to roll off the audio response below 200 Hz, thus attenuating wind roar and lots of other distracting sounds. I actually shot some footage in the car while we were travelling to the show, and car noise, while loud was not too intrusive and certainly didn't stop normal conversation being recorded. I suspect many a professional sound recordist would have killed for a system this good ten years ago.

marketing and technical expertise could sometimes be insufficient to sell a product to the public. Since it was introduced, the Beta format half-inch tape has lurched from one crisis to another.

To recap: the 1970s were a great time for video miniaturisation. At the start of the decade 'state of the art' was two-inch tape, requiring huge machines that could fill a small room, cameras so big they needed two men to carry them. Then came, in a rush, one inch for professional broadcasting, three-quarter inch, and then half-inch for domestic applications. Unfortunately, the standardisation system broke down at half-inch tape, and instead of one common format, people had to choose between two incompatible systems, Beta and VHS.

By the end of the decade the tape size was all set to be halved again, as Hitachi and Bosch readied themselves for release of a quarter-inch tape camera for the professional market. At the same time, the Sony corporation was in the final stage of development of a metric equivalent: 8 mm.

Meanwhile, Sony executives were begin-

ning to realise they had a problem with half-inch tape. In spite of running a technically superior product, it was obvious that they were losing the war against the VHS format. It's difficult to know why. At various times industry observers have blamed bad timing, pricing, software support, even the weather. In any event, Sony was stuck with a market loser, not losing money exactly (at least according to Sony itself), but certainly not in a position to take advantage of market development.

In the circumstances the last thing Sony wanted was more competition for the beleaguered Beta format, at least not until it could put itself in a position to exploit competition. In effect, this meant it had to get industry agreement on a new standard for 8 mm.

Of course, everyone else in the industry was also watching the situation develop and making calculations on where their interests lay. The VHS manufacturers were on a good thing and could do without competition. But on the other hand no one can afford to be off the bandwagon once it starts rolling. Meanwhile film makers, Kodak, Polaroid and Fuji among

others, were starting to recognise that they were risking being left on the shelf by having no interest in the electronic media. In spite of continuing evidence of the durability of film, they felt like hedging their bets.

As a result of all these conflicting interests a committee was set up in 1981 to consider the question of a standard for video. The early '80s were boom times for video makers though, and the VHS camp ensured that nothing much happened. Then in 1982 a recession started, and everyone began to think about new ways to stimulate demand. Some far sighted people in the VHS camp also started to worry about another threat to their market interests, the Koreans. The Japanese were right to be worried, as predictions are that Korean VCRs will be at least 25 per cent cheaper than equivalent Japanese models when they start to hit the market in bulk next year.

In the event a new standard for 8 mm video was agreed on by 127 companies representing all the major tape and equipment manufacturers around the world. In early 1984 the agreement was signed and ▶



products started to hit markets in Japan soon afterwards. People in the PAL countries had to wait a bit longer.

The actual marketing arrangements are curious to say the least. Sony, reeling under a further six per cent reduction in demand for Beta to September 1984, was eager to roll, and had products on the market as soon as possible. But the other Japanese manufacturers have been rather less forthcoming, entering into all kinds of

THE TAPE

As much as anything, 8 mm technology is due to improvements in the tape itself. Some fairly graphic numbers illustrate the process: one minute of recording consumed 3654.55 sq cm on a one inch BVH system in 1979. The U-matic standard needed 1089.28, while VHS standard play could get away with 177.53. Beta pushed this down marginally to 141.93. Standard play 8 mm comes in at 96.24. In the long play mode this is compressed even further into 48.12 sq cm.

The standard approves two types of tape for use on 8 mm video: metal powder (MP) and metal evaporated (ME) tapes (see Figure 1).

MP tape consists of three distinct layers bonded together in a sandwich. There is a central substrate nine microns thick with a one micron back coating and a three micron magnetic coat on the front. The magnetic coating consists of a powder of alloy of iron, nickel and cobalt and of course, provides the magnetic storage medium. The backing layer is there to provide a surface for the transport to grip onto.

ME tape is much the same as MP in construction, although manufactured by a very different process. The metal is first heated to a gas, then deposited on the tape in a vacuum. This method allows a precisely controlled, exceptionally pure and very thin layer of metal (0.15 μ m thick) to be deposited on the substrate. Individual particles of metal can be made exceptionally small, in fact, according to Sony, its tape features particles 1/25 the volume of the particles on its Beta tapes.

There were two major questions surrounding tape technology when the decision to implement 8 mm video was made. One concerned the signal-to-noise ratio that could be obtained and the other, the high frequency response. Not that it was a problem to get adequate figures, since quality video tapes have been around for years. The problem was to get it in a format compact enough to fit into 8 mm equipment.

This explains the quest for small particle size in the metal layer. The size of the particles is one of the critical determinants of the high frequency response of the tape. The smaller the particles, the faster the magnetic information on the tape can vary, the higher the frequency response of the system. ME tape in particular, offers very small particles, of the order of 0.15 μ m or less.

The other route to high frequency response is via increased tape-to-head speed. In 8 mm technology the tape runs at 20.05 mm per second,

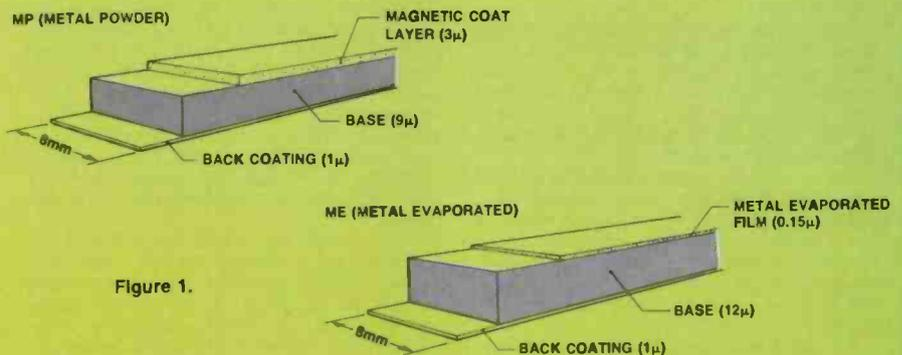

Figure 1.

which is increased significantly by putting the heads on a drum and rotating the drum against the tape as it slides past. This raises the effective speed to 3100 mm per second. This is certainly not exceptional by the standards of other video media. B format videos run at 5830 mm a second for instance. However, coupled with the small grain size it is sufficient to handle the 8 MHz required to make the format work.

The signal-to-noise ratio has been improved by a number of novel techniques in the tape itself, and in the interaction between the tape and the heads. For instance there has been the move to pure iron with very small admixtures of nickel and cobalt instead of the conventional Iron oxide. Pure iron has the ability to store far more magnetic energy. In fact it's four times better. As an extra advantage, high frequency signals are much more immune to degradation when on conventional tapes.

One objective measure of the quality of the tape is given by the hysteresis loop. The point D in Figure 2 represents the starting point. As the magnetic field (H) is increased, the degree of magnetisation of the tape (B) will also increase, but not in a linear fashion. In fact we soon arrive at a point, A, where further increases in the magnetic field result in no further increase in the magnetisation of the tape.

If we now remove the field, the degree of magnetisation of the tape will decrease, but not by much. This is demonstrated at the point B. This value of B, B_r , is called the residual flux density. In order to reduce it to zero, we must exert a magnetic force in the opposite direction, ie, re-

verse the polarity of the field. This happens at the point C. H_c , the coercivity of the tape, is thus the amount of magnetic energy necessary to reduce the magnetism of the medium to zero. Figure 3 shows a comparison of the hysteresis loop of Sony's Beta and 8 mm tapes.

A second technique has been the very close coupling achieved between the tape and the head itself, ensuring that as much energy as possible is transferred across the tape/head interface. This is achieved in two ways. Firstly, the metal surface of the tape has been made exceptionally smooth, almost glass-like in fact. This means the head can get really close to the tape without too many abrasion problems. Secondly the tape transport uses a complex loading mechanism to ensure that the tape is wrapped around the head drum for 221 degrees.

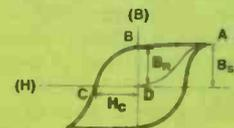

Figure 2.

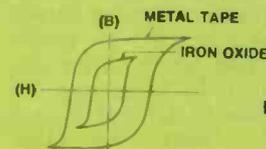

Figure 3.

strange deals with big US companies. Matsushita, known as National here, is selling all its products via Kodak. Toshiba has a similar deal with Polaroid. In addition, Sony itself is the source of components for many smaller companies now starting to enter the market in Japan.

These arrangements are working to everyone's advantage. For the Japanese it means a free ride while the film companies create a market. Conversely, for the American companies it means a chance to jump on the electronic bandwagon without hundreds of man years of research.

The big question of course is whether there is a bandwagon. Opinion is divided, many believe it's come and gone: Sony should have released 8 mm in 1981; now



THE PRODUCT

Just about every company in the world with a stake in consumer electronics has at one time or another played around with the idea of 8 mm video. Only a small number have ever demonstrated products however, and an even smaller number have plans to release anything in this country. In view of the rapidity with which Australians accept new technologies, that may well be a big mistake — in spite of the small overall size of our market compared to the US.

It's now possible to make a comparison between the three products for which specifications are available, the CCD 8, the Canovision 8 and the Kodavision 2000. The Sony and Canon products squeeze 90 minutes on to one tape in standard mode, 180 minutes in the long play mode. The Kodak, by comparison is rather profligate: only 60 minutes.

Other than that the technologies are convergent. The Sony has a 1.4 lens while the Kodak and Canon are marginally faster with 1.2. This is reflected in the minimum light figures. Kodak claims to be able to get results at 20 lux, Sony at 22. Either way, you'll be shooting in the dark. All cameras have zoom lenses.

All the units are camcorders with small playback facilities in the eyepiece. They have rf modulators included in the package to allow you to replay on a TV set. In the Sony and Canon products this is a little black box that plugs into the bottom of the camera. In the Kodak product it's part of the model 2020 cradle. Sony sells a tuner timer unit complete with infrared remote control, as does Kodak. However, in the Kodak unit all the elements of the system fit into the cradle, which is a rectangular box styled so as not to look out of place with the rest of a hi-fi system.

Of interest to the amateur movie maker will be editing facilities. According to Kodak, the editing facilities will be available for editing and dubbing between half-inch and 8 mm (or between two 8 mm units). However no details on price, availability or editing functions are available yet.

The Sony version is a flat panel that will control the CCD 8 plus most other recorders in the Sony, Panasonic or JVC ranges. You can keep track of up to eight individual scenes and link them together in any order you want. There are no plans as yet for any special effect or function generators, so you can only use straight cuts to link scenes. It will cost \$375.

THE 8 mm STANDARD

Like most consumer technologies, 8 mm video is defined by a standard that ensures that every manufacturer produces a product that does exactly the same thing. Thus all 8 mm tapes can be used in any 8 mm machine, and tape recorded in one machine can be played back in another.

For a start, the standard defines the cassette size to be 95 x 62.5 x 15 mm. Inside the cassette is a tape 8 mm wide, running at 20.05 mm a second. The tape runs past a spinning drum 40 mm wide that carries the heads.

The video tracks mark out diagonal lines across the tape. In the standard play mode the tracks are 34.4 µm wide. In long play this shrinks to 1.2 µm. This signal takes up 5.35 mm of the tape width, with an extra 1.25 mm being reserved for PCM audio. On both sides of the track there is a guard band 100 µm wide and then a 600 mm wide strip on both edges of the tape reserved for a stationary head.

Information on the tracks is laid down with frequency modulation. The spectrum of this signal is reproduced in Figure 4, and shows the luminance carrier (black and white information) at 5.4 MHz, the chrominance carrier (colour information) at 732.442 kHz, and the audio sandwiched between them at 1.5 MHz.

Clearly track finding is a major problem, since no flexible system like magnetic tape can be expected to track accurately to tolerance of the order of a few microns. Conventional systems use a separate control track, usually implanted by a separate head dedicated to that purpose. It's a simple system, but it suffers from the disadvantage that the distance between the control

head and the drum must be precisely known, and in practice it must be realigned every so often. The requirements of 8 mm video are much more stringent, so a system was developed that is inherently more reliable.

A system called ATF (automatic track finding) was developed by Philips to do the job. Four pilot tones (f1 to f4) are laid down along the tracks during the recording process. Frequencies are 101, 117.2, 162.8 and 146.5 kHz. In two head systems such as most of those developed to date, f1 and f3 are read by one head, f2 and f4 by the other. While one head is reading information off its track, the other head is comparing the value of the pilot tones in the other two tracks. If the system is tracking correctly they will be equal. Position can be maintained by changing either the tape speed or the head drum rotation speed.

Sound can be recorded on 8 mm in a number of different ways. It can be frequency multiplexed onto the video signal, as demonstrated in Figure 4, when an FM standard is used. Frequency deviation is 100 kHz. An alternative is to use PCM which is time multiplexed with the video signal. In this mode the first 30 degrees of the track are used for audio, the remaining 180 for video. PCM like this will allow two channels, as against the FM version's one. PCM uses eight 8 mm bits and offers a dynamic range of 48 dB.

A third audio application of 8 mm is to use the playback unit for audio applications only. When this is done the six high quality PCM tracks can be fitted on to one tape by dividing up the video portions of it.

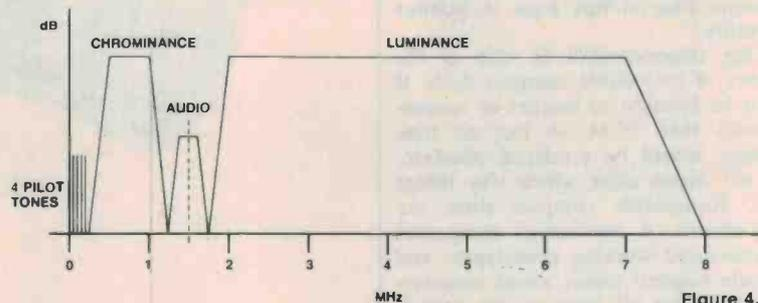

Figure 4.

THE HEART OF THE BEAST

half-inch is so firmly entrenched 8 mm will not be able to manage more than a fractional market share. There is something to this view, especially if the Koreans, as expected start hitting the market with really cheap VCRs next year.

There is also the question of prerecorded software, regarded by many as the *sine qua non* for any kind of marketing success for 8 mm. R. V. Klingensmith of Paramount Pictures has been quoted as saying that Paramount would require a market of at least a million machines before releasing software on 8 mm. Pirates may be expected to play a part in pre-empting the big studios, but even so, it could be years before 8 mm software is comparable to half-inch.

But 8 mm supporters have a number of points to make. Firstly, 8 mm is a new medium, with plenty of development ahead of it. Time will tell how small and cheap it is possible to make it. All things being equal, it should be possible to beat both Beta and VHS in size and price.

Secondly, there is a big market out there interested in home movies. It has kept camera and film makers happy for years, and may now be set to do the same thing for the video makers. Of course, this argument says there is no real contest between the two types of tape. Half-inch will continue to be the playback medium of choice, but don't bank on the success of half-inch camcorders. This is the argument that appeals to Kodak and Polaroid, and no doubt will be reflected in their marketing strategy.

The third thing that gives the 8 mm enthusiasts reason to hope is the emergence of a new PCM standard based on eight millimetre. Pulse code modulation is the only way tape mediums can approach the fidelity of compact discs. As CD becomes more popular a huge market will open up composed of people demanding similar fidelity from their recorded tape. A multi-role device would sell very well; in fact one company, Pioneer, has already announced a PCM audio/FM video device. The half-inch makers reply that half-inch can do anything 8 mm can do, and indeed it can, but it appears that 8 mm is already price competitive in this area. A pointer to the future?

The big imponderable in this is the emergence of recordable compact discs. If they can be brought to market at reasonable prices then PCM, in fact all tape technology, would be rendered obsolete. It's by no means clear which way things will go. Recordable compact discs are proving elusive. A number of companies have announced working prototypes, and even made hopeful noises about commercial releases, but all have so far proven hopelessly optimistic. I would bank on 8 mm being around for a while yet. ●

There are two competing technologies at the heart of 8 mm video: CCDs and mini camera tubes. The tube technology, epitomised by the Kodak newicon, is simply a miniaturisation of conventional camera technology. ('Simply' here is strictly relative, a fact obvious to anyone who compares the tube size of a 'state of the art' five year old TV camera and the newicon.)

But there is no doubt that most interest is fixed on the CCDs being used in a domestic application for the first time. One way of thinking of them is as a large array of photo diodes all fabricated on one piece of silicon. More accurately, they are a grid of photo sensitive metal oxide semiconductor (MOS) capacitors each coupled together in such a way that the charge on any one of them can be transferred from one to the other.

The individual elements of the CCD array can be packed extremely close together by using photolithography. The Sony model features a matrix of 500 by 582 in a package of 3.1 x 2 x 0.45 mm. The result is a potential for extremely high definition reception. It also makes it possible to transfer the charge from one cell to the other.

The elements are stacked one on top of the other to form columns in the matrix. Each column has a vertical shift register associated with it, made up of non-photo sensitive CCDs. In operation, incident light impinges on the CCD which charges up to a level proportional to the intensity of the radiation. The charge is transferred into the associated shift register during the vertical blanking interval. The charges stored in the shift register are then transferred down, row by row, into a horizontal shift register during the horizontal blanking interval. This is another non-photo sensitive CCD, and is used to transfer the information to the rest of the electronics at a rate of 9.4 MHz.

Colour information is obtained by having the usual RGB filters over the sensors, so that some are sensitive to red, some to green and some to blue. Decoding of this information is done inside a scan generator chip which has to be able to tell that a particular charge, coming out of the end of the device was generated in a red, green or blue cell.

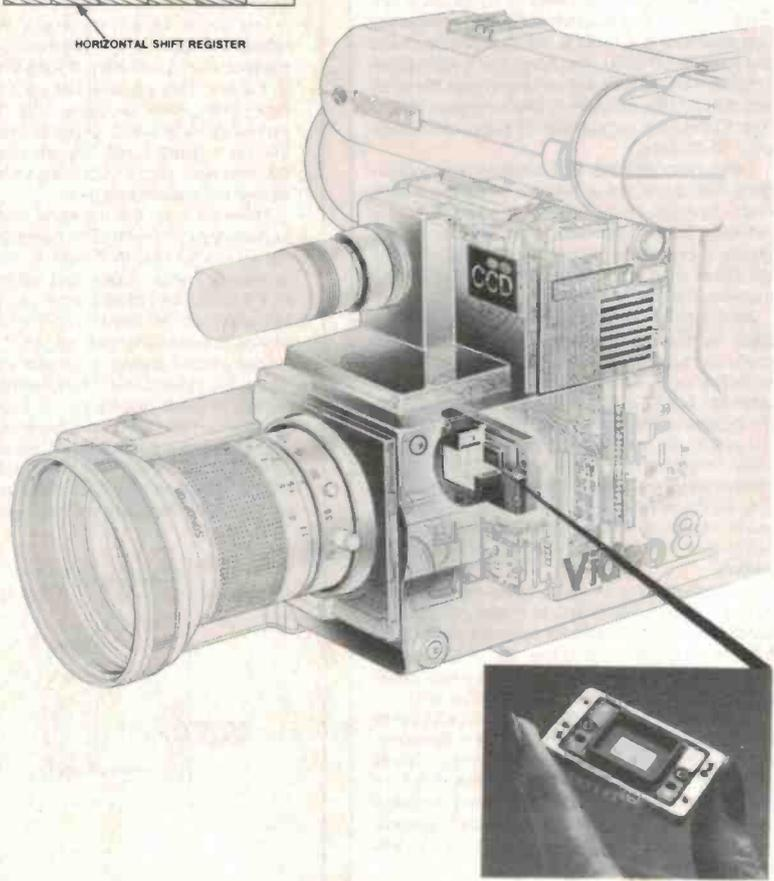
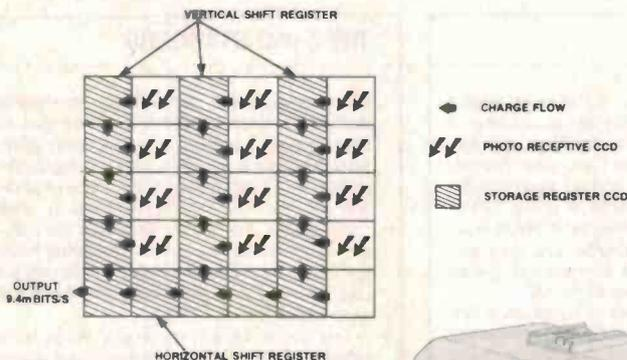

ARCHIVE COMPUTER SERVICES SYDNEY PTY. LIMITED

(INCORPORATED IN N.S.W.)

Microcomputer Products — Sales & Specialists



SOFTWARE:

- Suppliers of computer software including:
VIDEOTEXT, SPREADSHEETS, WORD PROCESSING, COMPILERS, DATA BASES, GRAPHICS and much more. Most operating systems are supported. Now available
- SMART MODEM 1200 — SM 720**
 The SmartModem 1200 is a high performance full duplex modem designed to work at varying speeds of up to 1200 bps on normal 2-wire "voice" grade General Switched Telephone Lines. **\$1038**
- SMART MODEM 2400 — SM 730**
 The SmartModem 2400 is a very high performance full duplex modem designed to work at varying speeds of up to 2400 bps on normal 2-wire "voice" grade General Switched Telephone Lines. **\$1650**
- P.C. IN/MODEM/VIDEOTEXT — SM715** **\$742**
- OLIVETTI M24**
 Faster than a speeding IBM P.C. 2x360 kb diskettes, Mono Screen, 256 kb Ram, IBM compatible MSDOS. **\$3665**
- Just released and selling like hot cakes the **PRESIDENT JR IBM compatible**. Use it at home or in the office. Includes free software. **\$1790**
- OLIVETTI M24**
 Even Faster again. 1x20Mb Hard Disk, 1x360kb diskette, Mono screen, 256kb Ram, IBM compatible MSDOS. **\$5641**
- 64k Chips — 150 NS \$2 — including tax.
- SHOP 13, Level 3 MOUNT STREET PLAZA, CNR MOUNT & WALKER STREETS, NORTH SYDNEY, N.S.W. 2060**
(02) 923-1200

Are your current tweeters ferrofluid cooled?



DALI (Danish American Loudspeakers Incorporated) believe that it's what goes into loudspeakers which makes what comes out of them both different and better.

Their choice and design of components is superlative — and so is the musical result they achieve. DALI will not hear of cheap vinyl cabinets, nor flashy looking drivers from the Far East. A DALI speaker is crafted from Danish wood — powered with Danish quality drivers.

A simple, but vitally important, fact is that all DALI tweeters are ferrofluid cooled. This allows for both cleaner and tighter detail as well as high power handling. In the era of the compact disc, a critically important feature.

Listen to the DALI difference at your nearest DALI dealer soon. At prices ranging from \$400 to \$2,000 they are definitely in a class all their own.

DALI DISTRIBUTORS
 PO Box 242, Hawthorn, Victoria 3122. Telephone (03) 8195352



Return this advertisement for a 5% Discount.



BURGLAR ALARMS AUSTRALIA

1064 Victoria Rd., West Ryde.
Ph: (02) 858-3211



SUPPLIERS OF QUALITY ALARM EQUIPMENT

- STOCKETS OF:**
- Controls: NESS, EFCO, IEI
 - Detectors: ELKRON, GUARDALL, RACAL, COLORADO
- Trade discounts to approved customers**



GRUV-GLIDE

THE 15° SOLUTION TO RECORD WEAR

GRUV-GLIDES claims of complete record care and protection are now accepted by most discerning record users. Gruv-Glide replaces all other record cleaning methods in one simple application. Gruv-Glide will actually improve the sound from your records (old and new). You can make the test by taking one of your own records to your local Gruv-Glide dealer. Gruv-Glide will also remove old record cleaners that clog your stylus, and at around 15° a record is a most economical treatment.

Gruv-Glide really works.

For more information:
LEISURE IMPORTS
 401 Pacific Hwy,
 Artarmon, 2064.
 (02) 438 4166



PERTH CES David Kelly

The Perth Consumer Electronics Show has traditionally been a major venue for the release of hi-fi and video equipment in Australia. This year's show was an indicator of things to come.

THERE ARE Consumer Electronics Shows and consumer electronics shows. It's easy, having seen a few mediocre events, to be a bit cynical about them all. Not so the Perth CES held in August. Organised by the consumer electronics industry in WA, the show was well run and attracted every significant supplier of hi-fi and video, and many of the home computer makers.

Exhibitors at the show spared little in effort and money to make their exhibits attractive and to get many hi-fi and video products on show to the public for the first time in Australia. Quite a few items were shown up to six months ahead of release.

Audio products easily dominated the affair. Interest in CD players is bringing people back into hi-fi shops and the suppliers of equipment are predicting a very busy year ahead. One exhibitor at the Perth show said that 90% of the people on his stand were asking about disc players.

Satellite ground stations and camcorders (video cameras/recorders) were also talking points of the show, but because of their cost didn't attract the biggest crowds.

WA technology

Ahead of the public opening of the show, trade and industry visitors were treated to a day of consumer electronics seminars. The first of these was about the activities of an innovative WA company, the Parry Corporation, given by its communications division manager George Chapman.

Chapman outlined two significant research and development projects of Parry. The company is developing a 50 cm planar array which it says will replace 1.2 m parabolic satellite earth station dishes.

The other project is a new technique for etching integrated circuits. The plasma etching technique was developed at the Australian National University and will be commercialised by Parry. It will result in high speed and accurate etching of chips at a cost only a little above the traditional, and slow, diffusion oven method.

The Parry Corporation is also promoting a computer controlled interactive laser disk which has, among other uses, applications in the travel industry. Using a \$15,000 laser disk system travellers of the future will be able to inquire about tours, get accurate fare and timetable information and even see video clips of places they would like to visit.

Satellites

Western Australia has a special interest in satellites; it has a large remote population with no television and even its capital city broadcasters have to pay more than anyone else to get programmes over the existing communications links.

AWA, Homesat, Acesat and Videosat all exhibited earth station equipment and at least two were taking orders from the public. To receive television, viewers will have to buy a BMAC decoder, which at \$1500 makes up more than half the system cost.

Although the Australian satellite is now flying, everyone will have to wait till the BMAC decoders become available from the sole supplier, Plessey, in November.

Systems

In case you hadn't noticed, many of those new CD players on the market come in the midi width of 350 mm not the currently common 430 mm maxi width. This is a not

so subtle hint to the public to buy a new (midi) system to match the new CD player.

It is also an indicator of a trend catching up on Australia: midi hi-fi components, especially system components that connect together through a special cable or connector. With the connector systems, connectors on the top and bottom of components mate when the components are stacked.

There were a lot of systems at the Perth show. Technics, Mitsubishi, Aiwa, Pioneer, Sony, JVC and Sharp had midi systems on show. Sony and Akai had maxi systems.

One of the most elegant solutions was the 100 W Mitsubishi E63 available through AWA. It had remote control, one control panel, one ribbon interconnect cable and one power cord.

CD players were of course the driving force behind the new interest in hi-fi and there were a lot of them on show (see Table). They ranged from the cheapest, the \$449 Toshiba XRV-11, to the most expensive, the Technics SLP-50, being offered to radio stations at \$7500.

Of the few companies that will have 8 mm camcorders in Australia by Christmas only Sony was able to tell the public much about it. And Sony did it with style. It had plenty of camcorders to play with and good monitors to replay on.

Hitachi, National and JVC also weighed in with VHS camcorders all attracting enough interest to show that a lot of people will buy these devices in the coming year.

Pioneer, Kenwood and Sony showed car CD players; Sony, Pioneer and Eurovox demonstrated AM stereo receivers for cars.

Outside cars though, there was little in the way of AM stereo, except for a good showing by Pioneer and Sony.

Among the novel at the show were NEC, Akai and Technics with surround sound, Akai's with full Dolby movie surround sound decoder, and Philips with a CD player that displayed the text of songs along with the sound.

The weird award goes to Pioneer whose Bodysonic chair has transducers to make it vibrate with the sound. I think they were showing it with the movie "Earthquake"!

CD PLAYERS ON SHOW

Less than \$500

Hitachi	DA500	\$499	midi
Sony	D50	\$459	portable
Sony	CDP30	under \$500	midi
Sony	CDP70	\$499	maxi
Toshiba	XRV11	\$449	midi
Toshiba	XR40	\$499	maxi
NEC	509	\$499	maxi
Sharp	DX100	\$499	midi
Philips	CD10	\$499	portable

\$500-\$600

Philips	CD104	\$569	midi
Technics	315	\$579	midi
Yamaha	CDX2	\$549	midi
Pioneer	PD5010	\$559	maxi
Hitachi	DA501	\$549	midi

Over \$600

Kenwood	DP840	\$799	maxi
Kenwood	DP1100	\$1499	maxi
NEC	709	\$799	maxi
Akai	CDM88	\$649	midi
Akai	CDA7	\$649	maxi
Yamaha	CD3	\$749	maxi
Nakamichi	OMS5	\$1795	maxi
Technics	CDP3	\$889	maxi
Philips	CD204	\$649	maxi
Philips	CD304	\$699	maxi

These prices were quoted by the companies as recommended retail prices and may change as a result of the show or in individual shops.

Eliminate hot sites faster. HP's complete family of protocol analyzers. All compatible.

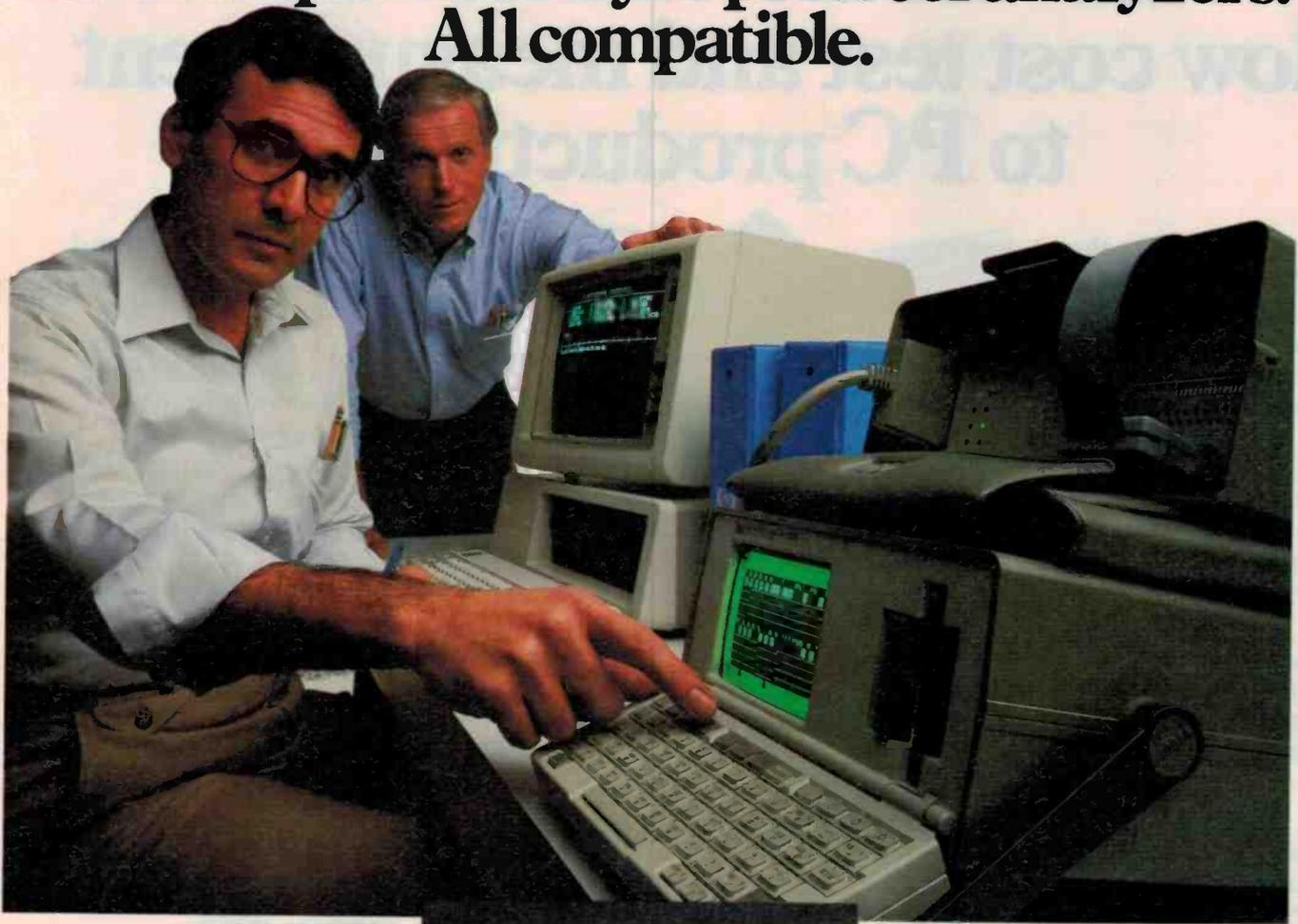

HP is the first company to offer you a complete family of protocol analyzers that are all data-compatible. Now, you can quickly identify and solve network problems — without having to recreate them for analysis at each organizational level.

Clear lines of communication with remote capability

For the first time, you can have a clear line of communication from the customer's hot site to your district or regional service center — even to R&D if necessary.

All HP protocol analyzers permit remote transfer of data and test programs, so you have high-powered analysis wherever you need it. Captured data and test programs written on one HP analyzer can be transferred to any other remote unit.

Now your field service personnel have direct access to the technical resources they need to solve even the toughest problems



in the shortest possible time — no matter how dispersed the network is geographically.

Software extends flexibility

With three HP protocol analyzers to choose from, you don't have to buy any more performance than you need. You are also assured continuing software support — a comprehensive package for X.25 certification and testing as well as powerful decode and simulation packages for SNA, X.21, CCITT #7, and the other protocols you need.

Quick and easy measurements

All HP protocol analyzers feature a common human interface — menus, decoded displays, ASCII keyboards, and softkeys that quickly and easily guide you through your measurements. Learn how to use one HP protocol analyzer and you can use them all.

For details about the HP family of data-compatible protocol analyzers, call Hewlett-Packard.

Melbourne: 895-2895,

Sydney: 888-4444,

Adelaide: 272-5911,

Perth: 383-2188,

Brisbane: 30-4133,

Canberra: 80-4244.



**HEWLETT
PACKARD**

Now Hewlett-Packard ties low cost test and measurement to PC productivity.

Introducing the HP Personal Computer Instrumentation System – conduct test and measurement and business applications at the same workstation.

It's a new concept in test and measurement. A system which offers a more efficient, cost saving way to program and perform test procedures, analyse and compare data, and record and plot results.

A system which enables you to simultaneously monitor and control as many as eight instruments – for example a D.V.M., a Digitizing Oscilloscope, a Function Generator – from the screen of your PC.

For HP 150's & IBM PC's

Simply connect the instruments and accessories of your choice to your HP 150 Touchscreen, or IBM PC, PC/XT, or PC/AT personal computer and load the System Software.

Now you can perform test and

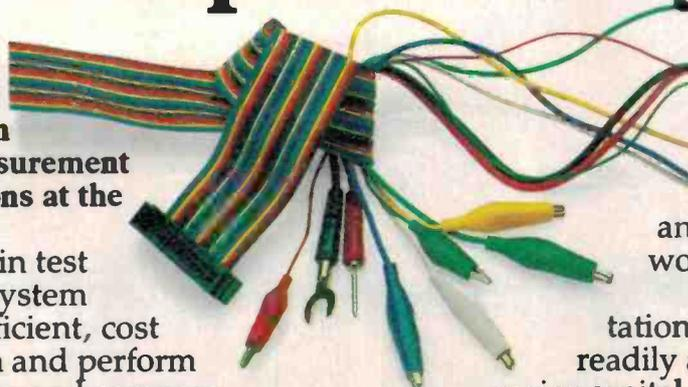

measurement and run business applications like word processing and spread sheet analysis at a single workstation.

HP's PC Instrumentation System makes all this readily achievable without major capital outlay.

Discover how to improve your productivity by putting the system to work for you.

Phone HP – the instrumentation leader – to arrange for a demonstration today.

Melbourne: 8952895, Sydney: 8884444, Adelaide: 2725911, Perth: 3832188, Brisbane: 304133, Canberra: 804244.



**HEWLETT
PACKARD**

Leo Burnett 7218 HEP 90474





PC Instruments

See advertisement on opposite page

I am interested in

- Technical Data
- Attending a technical seminar on Hewlett Packard PC Instrumentation



HEWLETT PACKARD

I currently have an HP 150 IBM PC

My application would be

- Prototype testing
- Component evaluation
- Temperature monitoring
- Environmental testing
- Academic research
- Other
- Biological research
- Analytical chemistry
- Botanical Research
- Education

Name

Company

Address

..... Pcode

Phone

SALES OFFICES

Hewlett-Packard Aust. Ltd.
31-41 Joseph Street,
Blackburn, Victoria 3130
Phone: 895-2895
Telex: 31024

Hewlett-Packard Aust. Ltd.
17-23 Talavera Road,
North Ryde, N.S.W. 2113
Phone: 888-4444
Telex: 21561

Hewlett-Packard Aust. Ltd.
153 Greenhill Road,
Parkside, S.A. 5063
Phone: 272-5911
Telex: 82536

Hewlett-Packard Aust. Ltd.
261 Stirling Highway,
Claremont, W.A. 6010
Phone: 383-2188
Telex: 93859

Hewlett-Packard Aust. Ltd.
10 Payne Road,
The Gap, Qld. 4061
Phone: 30-4133
Telex: 42133

Hewlett-Packard Aust. Ltd.
121 Wollongong Street,
Fyshwick, A.C.T. 2069
Phone: 80-4244
Telex: 62650

also

Hewlett-Packard (NZ) Ltd.
4-12 Cruickshank Street,
Kilbirnie, Wellington 3
Phone: 877-199

Hewlett-Packard (NZ) Ltd.
5 Owens Road,
Epsom, Auckland
Phone: 687-159

Electronics Today

READER SERVICE

POST FREE

No postage stamp required
if posted in Australia

FREEPOST No. 4

The Federal Publishing Company

PO Box 227

WATERLOO, NSW 2017

Electronics Today

READER SERVICE

POST FREE

No postage stamp required
if posted in Australia

FREEPOST No. 4

The Federal Publishing Company

PO Box 227

WATERLOO, NSW 2017

No postage stamp required
if posted in Australia

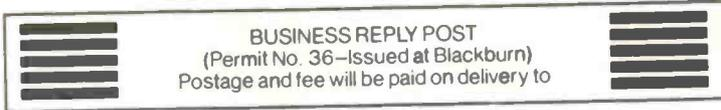

**INSTRUMENT DIVISION
HEWLETT-PACKARD AUSTRALIA LIMITED
31-41 JOSEPH STREET
BLACKBURN, VIC. 3130**

Attention: Glenys Taylor

**Find
it hard
to keep
on top
of —**

test equipment and
fault finding

amateur radio
dx, communications

circuit techniques
and design

constructional
projects

electronic music
and audio/video

computing
software

reference and
data handbooks

special
offers

???

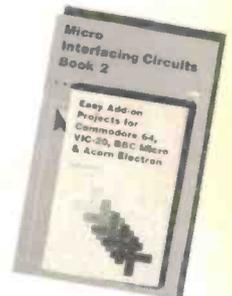

See our catalogue of
BOOKS in this
issue!

**Federal Marketing
Book Sales**

Electronics Today

READER INFORMATION SERVICE

To obtain further information from any of the advertisers in this issue, please fill in their code number (plus any product code number, e.g., 0711/Cat. 7894) in the boxes below:

Areas of Interest

- New products/equipment
- Radio/communications
- Computer hardware
- Audio/hi-fi
- Circuit design
- Industrial control
- Computer software
- Video/television

Reader Category

- Regular buyer
- Casual reader
- Subscriber

- Engineer/designer
- Technician
- Manager
- Hobbyist
- Interested consumer

NAME:

ADDRESS:

POSTCODE:

Please tick the appropriate boxes:

Electronics Today

READER INFORMATION SERVICE

To obtain further information from any of the advertisers in this issue, please fill in their code number (plus any product code number, e.g., 0711/Cat. 7894) in the boxes below:

Areas of Interest

- New products/equipment
- Radio/communications
- Computer hardware
- Audio/hi-fi
- Circuit design
- Industrial control
- Computer software
- Video/television

Reader Category

- Regular buyer
- Casual reader
- Subscriber

- Engineer/designer
- Technician
- Manager
- Hobbyist
- Interested consumer

NAME:

ADDRESS:

POSTCODE:

Please tick the appropriate boxes:

Electronics Today's FREE Reader Information Service

This service is designed to make it easy for readers to receive further information on the products and services advertised in this issue of Electronics Today.

Look up the name of the advertiser in the index at right and transfer the code number shown to a box on one of the tear-out reply-paid response cards opposite. To specify a particular product, you may need to add a code number (eg, product code number) shown in the advertisement itself. Do this for up to six products, if you wish. Then fill in the rest of the card and drop it in the mail.

We will direct your enquiries to the advertisers concerned so that they can send you the information you've requested. It's easy, avoids cutting up your magazine and saves you the time and effort of writing letters. But remember to fill in the complete card, to ensure that you get the information you want.

The cards in this issue must reach us before the end of the month of publication (ie, the month on the cover).

NOTE: This Advertiser Index and Reader Information Service are provided as an additional service to readers. The publisher cannot assume any liability for errors or omissions. The absence of a code number for any advertiser indicates that no further information is available for the products advertised.

ADVERTISERS' INDEX

Advertiser	Code	Page Number
ACME Electronics	10001	OBC
Active Electronics	10002	62
All Electronic Components	10003	97
Allen Bradley	10061	102
Altronics	10004	42,43,44, 45,46,47
Applied Technology	10005	26,27
Archive Computer Service	10079	15
Audio Engineers	10062	121
Australian School of Electronics	10057	99
Burglar Alarms	10045	15
BWD Industries Ltd	10046	120
Coltronics Trading Co	10081	Supplement 13
Cooper Tool	10009	Supplement 23
Dick Smith Electronics	10012	35,79,87, Supplement 2
Eclipse Computer Systems	10028	84
Emona Instruments	10052	104
Energy Control	10017	90
ETI books	10019	103,105,106
Geoff Wood Electronics	10044	Supplement OBC
Hewlett-Packard	10021	17,18
Hi-Com Unitronics	10068	120
IEI (Aust) Pty Ltd	10051	78
Jaycar Electronics	10023	60,61,68,69
Leisure Imports	10024	15
Lovelock Luke	10087	Supplement 17
Marist Bros Art Union	10071	34
Multicore Solders	10086	Supplement 7
Pacific Electronics	10082	40
Philips	10027	9
Prepak Electronics	10029	104
Racal-Milgo	10080	25
Robert Ford & Co	10047	98
Rod Irving Electronics	10031	41,50,51, 74,75,117
Rose Music	10032	IFC
Royston Electronics	10085	Supplement IFC
Scan Audio	10033	15
Scientific Devices	10083	99
Scope	10034	4
Siemens Ltd	10035	59
Sony Australia	10037	33
Statronics	10074	120
Subscriptions offer	10088	107
Syntec	10089	IBC
Telecom Australia	10075	28
Truscott	10039	96,106
Wireless Institute of Australia	10041	58

DATA COMMUNICATIONS

— the search for the ultimate transmission

Jon Fairall

Access to data communications is no longer only available to the skilled computer user. The pool of affordable modems, the increasing number of Telecom services and the growing population of personal computers are making electronic transfer devices the medium of the 80s.

WE HAVE BEEN a little taken aback by the interest in the ETI-699 (May '85). Modems are the new craze; to '85 what bobby sox were to '55 and mini-skirts to '65. If you feel left out in the cold, without the faintest idea why anyone would want to spend \$100 building a modem, then read on, this story is for you.

A modem is used to connect your computer to the telephone lines so that it can access other data machines. Paul Beaver, head of Dick Smith Electronics customer services, says modems will lead to the first really practical use of domestic computers. Indeed, the number of applications is enormous. You can use your computer to communicate with other people with interests like yours, engage in an increasing array of

financial transactions, order various services and so on. And the list is growing all the time.

If you want to know how modems work read the May edition of ETI in which Geoff Nicholls gave a good grounding of all the ins and outs. Fundamentally, a modem (MODulator/DEMODulator) modulates a computer output so that it can be transmitted over the telephone lines. In Australia that means transmitting at frequencies between 300-3400 Hz. The standard modulation method is frequency shift keying (FSK), in which a logic 1 is assigned a value of one frequency and a logic 0 another. The CCITT V21 standard in use in Australia specifies 980 and 1180 Hz if the modem originates the call and 1650 and 1850 Hz in

the answer mode.

There are two types of modem of interest to the domestic user: those that run at 300 baud and those that run at 1200/75. One baud equals one unit element in the pulse train per second. Thus a signalling speed of n baud implies a signal element length in $1/n$ or n bits per second. The 300 baud speed is used for most transmissions by microcomputers so all the cheaper modems use it. Another protocol that is becoming very popular is 1200/75. Signals are received at 1200 baud and transmitted at 75.

Apart from a modem the other thing you need to get talking is suitable software, a communications package. This directs output from the computer to the modem and sets up the appropriate protocols. Protocols are the standards of transmission and error checking that allow your computer and the computer to which you are connected to operate in the same way.

The simplest protocol is called Xon/Xoff. Indeed it's hardly a protocol at all, since all it does is provide a mechanism for the receiving computer to make the transmitting

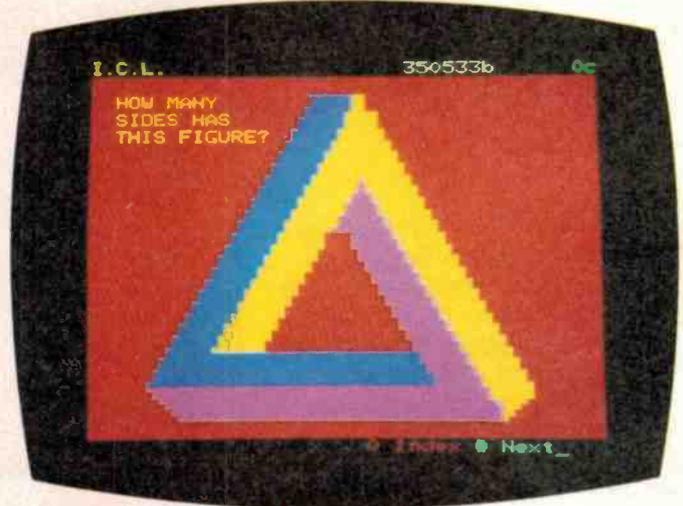
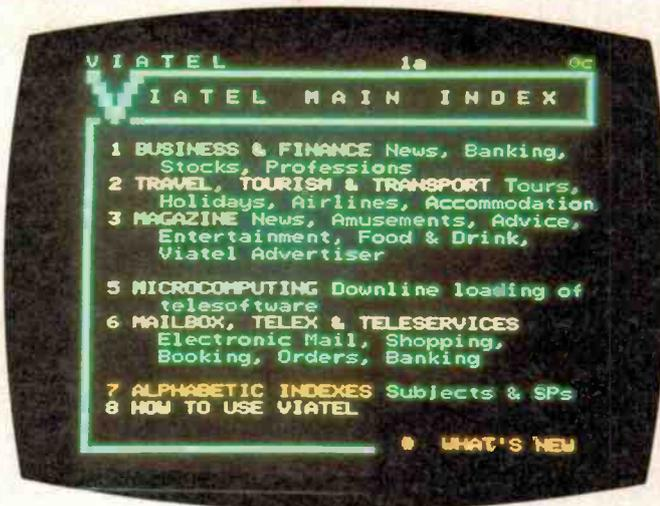

computer pause in appropriate places.

A more sophisticated beast is the Ward Christensen protocol, probably the most widely used among microcomputer users. This protocol was developed by Ward Christensen in the US for the CP/M Users Group. Programs using it include YAM (Yet Another Modem), MODEM and XMODEM.

Most of the popular micros have one of these programs or some variation of them available on ROM when you purchase one. The Microbee has Netcom or Telcom for instance. If you have any problems get in touch with one of the bulletin boards, which will be 'happy' to give you a public domain copy.

Computer talking

Modems add another new dimension to computing. You can get an idea of what this means as soon as your modem is up and running, by calling a friend and transferring files back and forth. However, unless you have some very specific applications, just transferring files of text or programs between computers can be pretty limiting.

One of the missing ingredients might be relevant software. Implemented correctly this can mean that both machines can be joined together to produce a much more powerful machine. For example there is a new trend in games software in which you compete with each other rather than the computer. A game called 'Mustang P51 Attack' takes the ubiquitous flight simulator program, 'Fighter Ace' and adapts it so that it runs on two computers simultaneously, the idea, as in real life, being to shoot the other fellow down. (It's worth \$59.95 from Paris Radio in Sydney.)

Bulletin boards

Another interesting application of a modem is to join the growing network of bulletin boards.

Bulletin boards are electronic meeting places. You leave messages, swap programs and tips, in general, exchange information with people who have similar interests to your own. The trick is to find a bulletin board that reflects your interests. A glance at the accompanying list will reveal boards dedicated to most of the popular micros, as well as several particular operating systems.

The sysop (systems operator) is the person who controls the bulletin board and thus determines the material it will hold. Sometimes he or she will have some vested interest of which the bulletin board is just one part. Retail store owners are a case in point. The bulletin board is used to provide mailing and ordering services for their customers, as well as technical information on their products, as part of ongoing sales backup.

There is a completely different type of sysop from the retail proprietor: the computer hacker who, in a fit of madness, decides that being a sysop is a Good Thing. These benighted individuals give up much money and considerable time to get their machinery up and running. Their

DIRECTORY OF TELECOM DATA SERVICES

Telex: The oldest and best established data communications network. Its transmission rate is 50 baud, but it has many thousands of subscribers. Terminal equipment tends to be stone age, and has been known to send people deaf. Two years ago Telecom discovered the VDU and made a half-hearted attempt to sell a new generation of machines, but it has all been superseded by the latest developments.

Teletext: The replacement for telex. It operates at 2400 baud and will possess gateway into the telex network to allow it to take advantage of the customers that already exist. It comes with personal computer style terminal equipment, including word processors, disk storage and printers. Interfacing a standard PC is simple.

Telememo: A variation of Teletext and using the same technology. It will work exactly the same way as a bulletin board, ie, you will be able to enter, leave and retrieve messages at will.

Datel: The basic business communications system. A choice of leased line permanently dedicated to the customer's use or switched line through an exchange is available. Transmission speeds are available between 300 and 48,000 baud.

Digital Data Service (DDN): An updated version of Datel for business communications, the system uses between 2400 and 48,000 baud x21 transmission standards. It multiplexes data streams along major trunk routes, but each

customer is guaranteed a full time service. Some typical annual charges: Perth-Canberra 19.2 kbs, \$23,220; Melbourne-Canberra 48 kbs, \$22,992; Sydney-Canberra 9.6 kbs \$2,592.

Auspac: Telecom's packet switched network. Access on 300 baud by dialling 01921, 1200 baud on 01922 and 1200/75 baud on 01923. These access numbers route a call through the telephone exchange to a PAD (Packet Assembler/Disassembler). This device assembles data from your computer into a 'packet'. The packet consists of an address header at the front, some data and an error checking group at the back. The entire packet can be up to 128 bits long. This is then sent over trunk lines in the direction indicated by the address. Typical transmission rate is 1.4 Mbs. The packet is sandwiched between other packets with the same address, so effectively the trunk routes are time division multiplexed with an indeterminate number of users. At the receiving end the reverse process occurs as the PAD separates out the packets, puts them into one long string and sends them to the destination computer. The advantage of this way of doing things is that high speed trunk lines are used to maximum advantage.

Vlatel: One of the services provided on Auspac. Direct access is by dialling 01955. See main text.

bulletin boards are more idiosyncratic, as benefits their status as amateurs, and elicit more intense likes and dislikes.

Electronic shops

As one would expect, Dick Smith Electronics is in the forefront of this type of bulletin board operator. There are a couple of other, smaller, operators around as well who have their own peculiarities.

The sysop at DSE is Paul Jones, who presides over an Olivetti M21 and an Avtek multimodem. Mass storage is on a 20M hard disk. At the time of writing there were 3368 registered users of the system and it was averaging about 3000 calls a month. Major uses to which the system is put: electronic shopping, customer support and chat-ter.

Electronic shopping at DSE is now a highly refined art. When you enter the system and select shopping from the menu, the system guides you through a sequence of questions that establish your name, postal address, order and Bankcard number. After confirmation from Bankcard the order is mailed to you, a service that takes less than 24 hours. (That's the theory anyway, and Paul Beaver assured me DSE is trying to make it work.) If you know the DSE product line it's far and away the easiest way of getting material from the company. The only real disadvantage is that the system runs from Sydney, so it takes the cost of an STD call to access from outside the metropolitan area. A (008) line is under consideration, so cheer up.

Another board of the same type is the Infocentre which is run by Paris Radio, a retail store in the southern Sydney suburb of

Kingsford. Infocentre has been running for about four years and is currently receiving about 1000 calls a month according to sysop Jacky Cockinos.

Like others of its type, Infocentre's main reason for existence is as an electronic shop front, and so there are large areas of the database set aside for electronic ordering and customer support services. These latter consist mainly of advice for owners of the equipment sold by Paris Radio. Currently there is several megabytes worth of space devoted to programs for Tandy and Sanyo computers.

In addition Paris Radio has special areas of the database available to people who pay the \$25 membership fee. These areas contain things like book reviews (written by a professional writer) and a message system.

Plans call for the establishment of Ward Christensen protocols within the next few months, which will allow the exchanging of binary files. According to Cockinos, one of the most interesting uses will be the creation of a graphics library using the CoCo Max package for Tandy Colour Computers.

One of the most unusual things about the Infocentre is that all the software to run it was originated in-house. It's designed for a 6809 system, called Access 09, and after several years of developing and debugging Cockinos has just put it on the market in the USA. He reports several expressions of interest from local and overseas operators.

Fun lovers

Boards set up by hackers just for the hell of it tend to be very different types of operation. For a start there is a much wider variety of equipment, much of it ▶

BULLETIN BOARD ACCESS NUMBERS

This is a selection of boards available in Australia. We have also listed a few overseas that use V21 format. Note that if you want to access boards in the US or Canada you will need Bell 103 format on your modem.

NEW SOUTH WALES

Abcom-IBBS
(047)36-4165
24 hours

Apple Users' Group RBBS
(02)451-6575
24 hours

Ausborne Users Group RCPM
(02)95-5377
24 hours

Augur BBS (AUGUR-BBS)
(02)661-4739
24 hours

Club-80 RTRS
(02)332-2494
24 hours

Dick Smith Electronics RIBM
(02)887-2276
24 hours

Infocentre RBBS
(02)344-9511
24 hours

Mi Computer Club RBBS
(02)662-1686
24 hours

Micro Design Lab RCPM
(02)663-0151
24 hours

Newcastle Micro Club RCPM
(049)68-5385
24 hours

Omen RTRS
(02)498-2495
Weekends: 24 hours
Weekdays: 1630-0800

Prophet TBBS
(02)628-7030
24 hours

RUNX UNIX
(02)48-3831
24 hours

Sydney Commodore 64 BBS
(02)664-2334
24 hours

Sydney Public Access RCPM
(02)808-3536
24 hours

TI User Group RBBS
(02)560-0926
Mon-Tue: 1900-0700
Sat: 1900-0000
Sun: 0900-0000

Tomorrow's Land
(02)411-2058
24 hours

ACT

Canberra IBBS
(062)58-1406
24 hours

Canberra RBBS
(062)86-6334
24 hours

VICTORIA

Am-Net RCPM
(03)366-7055
24 hours

Computers Galore RIBM
(03)561-8497
24 hours

East Ringwood RCPM
(03)870-4623
24 hours

Gippsland Mall-Bus
(03)27-7245
24 hours

Gippsland RCPM
(051) 34-1563
24 hours

Hi-Soft RIBM
(03)799-2001
24 hours

Melbourne CBBS
(03)762-5088
24 hours

Melbourne MCC
(03)762-5088
24 hours

Microbee User Group RCPM
(03)873-5734
24 hours

MicroPro Computers RCPM
(03)568-8180
24 hours

Omen-IV RTRS
(03)846-4034
24 hours

Sorcerer Computer Users 1 CBBS
(03)836-4616
24 hours

Sorcerer Computer Users 2 CBBS
(03)434-3529
24 hours

Tardis RCPM
(03)67-7760
Weekends: 24 hours
Weekdays: 1800-0800

Teletaille
(03)755-1341
Austpac ?237520000
24 hours

The Australian Beginning

(03)813-3522
Austpac ?238220000
24 hours

The PC Connection
(03)528-3750
Weekends: 1600-1000
Weekdays: 2100-0800

QUEENSLAND

ACEA Commodore BBS
(07)341-0285
24 hours

Bex II RCPM
(07)395-1809
24 hours

Brisbane Microbee RCPM
(07)38-4833
24 hours

Brisbane T.I. RBBS
(07)263-6161
Daily: 2100-0700

Cairns and District IBBS
(070)51-3582
Wed: 1800-0800
Weekends: 24 hours

Colour Computer Link
(075)32-6340
24 hours

Commodore Users BBS
(07)808-2125
24 hours

Compotron IBBS
(07)52-9294
24 hours

Hi-Tech C BBS
(07)38-6872
24 hours

Software Tools RCPM
(07)378-9530
24 hours

Texas Instruments
(07)263-6161
Weekdays: 2100-0600

Tomorrowland Direct
(07)286-2438
24 hours

SOUTH AUSTRALIA
Adelaide Micro Users Group RBBS
(08)271-2043
24 hours

Computer Ventures RBBS
(08)255-9146
24 hours

Electronic Oracle IBBS
(08)260-6686
24 hours

Omen V RTRS

(08)45-4666
1800-0700

Nexus Ed Dept BBS
(08)243-2477
24 hours

Multiple BBS
(08)255-5116
24 hours

SA Commodore BBS
(08)382-4631
24 hours

NORTHERN TERRITORY

Omen-II RTRS
(089)27-4454
24 hours

Outback RCPM
(089)27-7111
CCIT v.21 and v.23
24 hours

Red Centre RCPM
(089)52-8852
24 hours

WESTERN AUSTRALIA

Omen-III RTRS
(09)279-8555
24 hours

Perth RMPM
(09)367-6068
1800-2100

TASMANIA

Mike Scott's (MS-BBS)
(003)34-9411
24 hours

NEW ZEALAND

Attache RBBS
0011-649789084
24 hours

New Zealand Micro Club RBBS
0011-64-9-76-2309
24 hours

Rotorua BBS
0011-647370154
24 hours

SINGAPORE

Dr Data RCPM
0011-65-4-439181

SOUTH AFRICA

Cape Computer Club RBBS
0011-21-21-5363
24 hours

Cape Town Connection-80 RBBS
0011-21-45-7750
24 hours

begged and borrowed. Mass storage is strictly ad-hoc, very much a question of using what's available.

The Prophet is a case in point. The sysop is Larry Lewis. A computer analyst with the Commonwealth Bank in real life, his hobby is messing about with the bulletin board. When I spoke to him he had just managed to persuade AED to sponsor the system by donating one of its Universe Supercomputers to his system. It will form the basis of a multi-user bulletin board, although at the moment Lewis is held up by a lack of suitably cheap modems. Getting extra Telecom lines put on is also something of a problem.

Bulletin boards of this type tend to allow the serious user much greater freedom than

the retail stores. You can get into the operating system, play around, find out how everything works. Of course you will find yourself locked out of certain areas and unable to access some commands, but by and large the object here is only to prevent people destroying the board.

From the foregoing you may deduce that there are no special qualifications required to set up a bulletin board, and this is indeed the case. All you need is an auto answer modem and a telephone line. Endless patience and a bit of spare time help of course.

Telecom

At the centre of all this, like a spider at the middle of a web, sits Telecom Australia.

Telecom provides the transmission paths and sets the rules. Like any organisation in such a position it cops a fair amount of flack. Some of it deserved and some of it not. Also like any other bureaucracy, it is often its own worst enemy when it comes to tackling public criticism.

Whatever, Telecom Data Services sees itself as a cut above the pedestrian old phone supplier. It has discovered commercialism. It even knows about competition. Broadly speaking the modern Telecom view is that Telecom is a service provider, in the business of selling lines for communications. Within broad limits it has no interest in what goes on the lines. You are allowed to connect anything to the plug in your house

providing it conforms to Telecom safety regulations. These are fairly stringent, and centre around the possibility of 240 volts finding its way into the network.

This view has led to a wide range of terminal devices competing on the open market, in many cases competing directly with Telecom products. The existence of a more competitive environment seems in turn to be stimulating Telecom into providing a far greater range of services, and providing them at a far greater pace than it has ever done in the past.

Viatel

From our point of view the most interesting thing happening at the moment is the use of the packet switched network called Auspac to provide Viatel. You communicate with Viatel using a 1200/75 baud modem and some interpretive software that allows the computer to format the data correctly. (It uses low resolution graphics controlled by escape codes and a 40 column screen format.) See opposite for a list of suppliers.

The general structure of Viatel is that anyone who wishes to become a service provider can, upon payment of a monthly sum to Telecom, take some small part of the Telecom database and put whatever information is desired on it, and charge other people to view it. The basic cost to 'users' is \$2.50 a month. Alternatively, the service providers can have a gateway installed which permits access from Viatel into the provider's own computers.

The number of service providers and service users on Viatel is already quite considerable, and likely to grow at an alarming rate. At present subscribers are signing on at about 1000 a month, even before the home computer industry has focused on it.

You can already do all your banking (except get cash) from the Commonwealth Bank, look at TAA flight schedules and ask for a seat, or buy a range of wines and appliances from an outfit called the Cable Shop. Money Watch allows you to monitor the state of the Sydney or Melbourne stock exchanges. There's even a 'what's on' for Melbourne.

The services offered are being updated constantly. All the other banks can be expected to follow the Commonwealth and offer home banking very shortly. TAA is planning to update its services so that it will be possible to actually reserve a seat on a specific flight. Entertainment houses of all kinds will probably use it to advertise upcoming features, and allow booking with a variety of credit cards.

The future

This is only a brief account of what's available today. The situation is changing extremely quickly however, under pressure from a larger and larger number of users, and will continue to grow as the field moves from being the province of the computer buff to a tool used by the community at large.

VIATEL SOFTWARE

Both suitable software and a modem are required to connect microcomputers to Viatel. The following companies have been identified as being involved with the supply of Viatel software suitable for use with commonly available personal computers. This is not a complete list by any means, but it does give some idea of the range of product available.

Apple (those indicated with * do Macintosh as well.)		Corona	
AAV	(03)699-1844	Netcomm Australia	(02)498-5577
Netcomm Australia*	(02)498-5577	Microcorp	(02)27-1122
Rank Electronics	(02)449-5666	Techmedia	(08)212-2168
GEC	(02)887-6222	Ericsson PC	
Computerland*	(02)745-4311	Netcomm Australia	(02)498-5577
Eftec	(02)957-5788	Microcorp	(02)27-1122
Syscorp	(02)92-1907	Techmedia	(08)212-2168
Microcorp*	(02)27-1122	Hewlett-Packard	
Visionhire	(02)92-0902	Hewlett-Packard	(02)888-4444
Thorn EMI	(02)439-7411	ICL	
Techmedia*	(08)212-2168	GEC	(02)887-6222
Zephyr Products	(03)553-3266	Visionhire	(02)92-0902
Kurrawood Computers*	(045)78-2377	Thorn EMI	(02)439-7411
IBM		Techmedia	(08)212-2168
Netcomm Australia	(02)498-5577	ITT XTRA	
Rank Electronics	(02)449-5666	Netcomm Australia	(02)498-5577
Dotsoft	(02)449-6923	Microcorp	(02)27-1122
GEC	(02)887-6222	Techmedia	(08)212-2168
Eftec	(02)957-5788	Microbee	
Sperry	(02)929-7800	Applied Technology	(02)487-2711
Syscorp	(02)92-1907	Applied Technology	(043)24-2711
Microcorp	(02)27-1122	NEC	
Neologue	(02)487-2859	Neologue	(02)487-2859
Visionhire	(02)92-0902	OLIVETTI M24	
Thorn EMI	(02)439-7411	Netcomm Australia	(02)498-5577
Techmedia	(08)212-2168	Microcorp	(02)27-1122
Zephyr Products	(03)553-3266	Techmedia	(08)212-2168
Computer Electronics	(02)428-3236	Remington	
Computer Techniques	(057)21-8140	Remington	(03)699-4722
Avtec	(02)427-6688	Netcomm Australia	(02)498-5577
Commodore		Techmedia	(08)212-2168
(Vic 20 as well if indicated with *)		Sigma Multitec	
Microtex 666	(03)531-8411	Netcomm Australia	(02)498-5577
Dotsoft	(02)449-6923	Techmedia	(08)212-2168
GEC*	(02)887-6222	Sirius	
Visionhire*	(02)92-0902	Rank Electronics	(02)449-5666
Thorn EMI*	(02)439-7411	Syscorp	(02)92-1907
Zephyr Products	(03)553-3266	Sperry	
Rank Electronics	(02)449-5666	Sperry	(02)929-7800
Modem Technology	(02)634-3988	Tandy	
Techmedia*	(08)212-2168	Tandy	(02)675-1222
Megavision	(02)290-2655	Paris Radio	(02)344-9111
Ball Electronics	(057)21-6260	Telic Alcatel	
Kurrawood Computers	(045)78-2377	AWA	(02)638-8444
Apricot		Wang	
Syscorp	(02)92-1907	Neologue	(02)487-2859
Rank Electronics	(02)449-5666		
Neologue	(02)487-2859		
Aquarius			
Modem Technology	(02)634-3988		
BBC			
GEC	(02)887-6222		
Visionhire	(02)92-0902		
Thorn EMI	(02)439-7411		
Rank Electronics	(02)449-5666		
Techmedia	(08)212-2168		
Jacaranda Electronics	(062)82-5458		
Burroughs			
Burroughs	(02)922-9300		
Compac			
Techmedia	(08)212-2168		
Netcomm Australia	(02)498-5577		
Microcorp	(02)27-1122		
Computerphone			
(equipped for Viatel Is standard)			
Telecom Business Office			
(see front of telephone directory)			



The cultural scope of the new electronic lifestyle

MODEM SUPPLIERS

The following is a representative sample of modem suppliers. Inclusion in this list implies no particular endorsement from ETI, nor does omission imply censure.

Active Electronics, 289 Latrobe St, Melbourne, Vic 3000. (03)602-3499: Sells the Acetel multi modem with 300, 600 and 1200 baud standards and auto answer for \$349.

Applied Technology, 1a Pattison Ave, Waitara, NSW 2077. (02)487-2711: Produces a dedicated modem for the Microbee computer. It's switchable 300 or 1200/75 and worth \$169.

Case Communications, 1 Rodborough Rd, Frenchs Forest, NSW 2086. (02)451-6655: SB321 300 baud modem with auto dial and auto answer as optional extras. Available in rack mount or bench top configurations. A 1200/75 version called the SB1275 is also available. Price is \$595 for the basic version, an extra \$490 for the options.

Computerama, 4/912 Albany Hwy, East Victoria Park, WA 6101. (07)362-5882: Sells the First Nice Modem. It's a 300 baud modem with auto dial/answer 1200/75, 75/1200, 300 and the prize for the best name on the market. Sells for \$299.

Datacraft, Maroondah Hwy, Croydon, Vic 3136. (03)726-9911: Datacraft 5312 has 1200/75 and sells for \$627. The 500 MkII includes 300 baud and Bell 103 and sells for \$699. The 5003 has 300 baud alone, but features an auto answer facility for \$350.

Datatron, 54 Malvern St, Bayswater, Vic 3154. (03)729-2844: Sells a 1200/75 modem with auto dial and auto answer. Price on application.

Dick Smith Electronics, Waterloo Rd, North Ryde, NSW 2113. (02)888-7566: Dataphone 2. Runs at 300 baud, no frills, sells for \$199.

GEC, 2 Giffnock Ave, North Ryde, NSW 2113. (02) 887-6222: The Tandata TM110 1200/75 modem has auto dial and sells for \$292. The TM200 sells for \$487 and is switchable between 300 and 1200/75. It has auto dial. The TM512 will feature auto dial and auto answer facilities and will be available in November.

Jaycar, 117 York St, Sydney, NSW 2000. (02)267-1614: Sells the Avtek multimodem which has auto answer and both V21 and Bell 103 standards for \$349.

NEC, 646 Springvale Rd, Mulgrave, Vic 3170. (03)560-5233: Sells a switchable 300 and 1200/75 modem bundled with Viatel software for \$700.

Netcomm, 33 Ryde Rd, Pymble, NSW 2073. (02)888-5533: Supplies special modems for the Apple at \$558 and the IBM at \$848. A 1200/75 version is also available for the Apple, for \$730. A 1200/75 modem for the Commodore 64 is in the pipeline.

Paris Radlo, 161 Bunnerong Rd, Kingsford, NSW 2032. (02)344-9511: Sells Avtek (auto answer, 300 baud, \$399) and Cicada (\$199) modems. Also the Rainbow Bits 300, a 300 baud modem with inbuilt intelligence which sells for \$200.

Parity Computers, 472 Pacific Hwy, St Leonards, NSW 2065. (02)438-3222: Sells Sendata modems and Data Netcomm.

Eclipse Computer System, 1 Stralhaird Cl, Diamond Creek, Vic 3089. (03)438-2713: Sendata 1200. Price on application.

Racal, 47 Talavera Rd, North Ryde, NSW 2133. (02) 888-6444: Sells the 3414 300 baud modem, V21 standard for \$450. The PA21220 is switchable 300 and 1200 baud with both auto answer and auto dial facilities. It sells for \$1500.

Rod Irving Electronics, 425 High St, Northcote, Vic 3070. (03)489-3070: The model 303 runs at 300 baud, with both auto dial and auto answer Bell 103 and V21 protocols. It sells for \$199.

Rosser Communications, 4/1051 Pacific Hwy, Sydney, NSW 2073. (02)449-8233: Sendata 300/1200/75 costs \$344, the Sendata 1200/75 is \$306 and the CEI2123 which has switchable 300 and 1200/75, auto answer and auto dial is worth \$695.

Techway, 6 Lavender Rd, Milsons Point, NSW 2061. (02)929-4988: Sells the FDx 120 1200 baud modem. Price on application.

Telecom data services are multiplying like rabbits. A brief survey uncovered Telex, Teletex, Telememo, Datel, Digital Data Service, Auspac and Viatel. These services use a wide range of communications protocols, not usually found on the domestic modem, but they are of interest because Telecom's philosophy is to provide gateways between the various services. In theory, at any rate, it should soon be possible for any data machine anywhere in the country to access any other machine, irrespective of the network to which either machine is connected. Some of these gateways will be available in the very near future. Telex, Teletex and Telememo will be connected next year according to Ron Glasgow of Telecom's data products section.

Hacking

In spite of all the changes on the horizon, one thing is for sure: the propensity of human beings to break the rules will not change much in the future, whatever else happens. As we rely more on data communications to do many of the ordinary things of life — to pay a bill, use a Bankcard to order components for a kit, store important company information — we become more vulnerable to people with the ability to misuse the network.

Computer crime is always in the news; stories about how a bunch of kids penetrated the world's most secure computers and nearly started World War III, or stole a million bucks are part of modern urban myths.

Predictably, the bulletin boards are where most people learn about hacking. They are home turf for the people who have the interest and ability to do it. The problem is this: most bulletin boards attempt to constrain the behaviour of callers. If you phone an electronic shop like the Infocentre, for instance, you will be directed to a specified list of options and allowed to look at certain parts of the database. There will be private files with limited access (eg, other people ordering information) and commands for controlling the behaviour of the board (eg, to allow the sysop to delete files) to which access will be restricted.

The quest of the hacker then is to get into these areas. One way is to cause a system crash, since when the system detects an error it will naturally return you to the operating system. Then you can move around at will, satisfying your curiosity or destroying the bulletin board completely. Some hackers delight in completely erasing disks, or in replacing the information with garbage. Typical techniques might be typing Control C in the middle of a line, or giving strange answers to prompts, eg, an escape code or control characters.

Such people are not Good Friends with the sysops.

Of course this strategy depends for its success on the ignorance of the sysop. Once he knows where a crash occurs it's a comparatively simple matter to fix it up. In fact sysops seem to spend a great amount of



MacVideotex software on the Apple Macintosh and Videotex II on the Apple IIc are used in conjunction with the Apple modem 1200.

time trying to get into each other's systems, and then telling each other about it. Over time the system becomes more and more immune.

Another sabotaging strategy involves acquiring 'super-user', or sysop status. In virtually all systems the sysop gives himself or herself a special name/password combination that allows him or her to access all areas of the database and change it in any way he or she sees fit. The problem then becomes one of examining all possible combinations of password and name to see if one of them will let you into the system. The number of possible combinations is truly astronomical, so the standard way of tackling the problem is to develop a program to make the computer do it for you.

The standard counter to this method is to have the bulletin board disconnect the call after three tries. Of course you could get an auto dial modem and redial automatically, but it would get very expensive if every three tries cost the price of a local call. This method of protection is used by all the bulletin boards, and by a number of private networks that have reason to be security conscious. Maynet, run by the Mayne Nickless organisation is a case in point.

One of the criticisms made of Viatel is that it does not provide this facility. Because Telecom's brief is to make access to its network as easy as possible it only makes a single user name and number check at log-on. After that it's open slather. There is certainly no mechanism to disconnect unwelcome callers at the behest of the service providers. In principle there is no reason why a caller cannot try a million combinations in the hope of finding the correct one. The only limitation is the charging rate of the Auspac network itself. One answer is to make the computer record failed name/password combinations, and sound an alarm whenever this happens.

Of course this ignores the most common method of computer espionage, which is to steal or in some other way, obtain the password illegally, thus permitting perfectly straightforward entry into the computer. As a matter of fact this is how most of the world's great computer frauds have been perpetrated. The lesson being read by the publicity people at Telecom is that, if security matters, the first step is to make sure that the computer is in a physically secure environment and that all the dedicated lines are also secure.

According to Telecom, data in Auspac itself is relatively secure, since it is a packet switched network. There is no reason why one piece of data from your computer will be physically associated with another on any particular line, making it virtually impossible to decipher. However, this has not satisfied some of the big users of data communications. Mayne Nickless, and most of the banks have their own autonomous networks for transferring sensitive financial information.

Whether these networks are more secure one time will tell. Or maybe it won't, since

illegal penetration of networks is not something that the networks themselves are anxious to publicise.

Morals and the facts of life

Undoubtedly, doing something you are not supposed to do on a bulletin board is quite a challenge, especially as the easy options close up over time. However, damag-

ing the board is no different really from ripping up the seats on public transport. They both cause discomfort and hardship to other users. A vandal is a vandal whether sitting in a train or in front of a computer. An appeal from the sysops is in order: "If you want to mess in the joint, take your drop-pings with you."

Meet the friendly modems, from **Racal.**

Here are two modems that will help make your network a lot better. And what's more, they're friendly!



- Software controlled options, so you don't have to start modifying your hardware. That's friendly!
- Stores up to 10 telephone numbers in its own memory. (Handy!)
- Dials automatically . . . or manually. (Versatile!)
- Can be driven either by software or in immediate manual mode. (Adaptable!)
- 1200 BPS or 300 BPS asynchronous or 1200 BPS synchronous and talks to V22, Bell 212 and Bell 103. (Gregarious!)
- Has comprehensive self test operations. (Self reliant!)
- 8 character 8mm. high LCD display. (Honest!)
- Telecom approved. (Recognised!)

Here's another good friend, VP 1222 AC.

- Speeds: Asynchronous 0 - 300, 600 and 1200 BPS. Synchronous 600 and 1200 BPS. (Understanding!)
- Full duplex operation over 2-wire dial up or leased telephone circuits. (Two friends in one!)
- Out performs most other modems when the going gets tough. (Steadfast and true!)
- Telecom approved. (Well liked!)
- Fully meets International CCI TT V.22 recommendations. (Well qualified!)
- Proven worldwide. Same modem as supplied by Racal Milgo to postal and telegraphic commissions around the globe. (Worldly!)

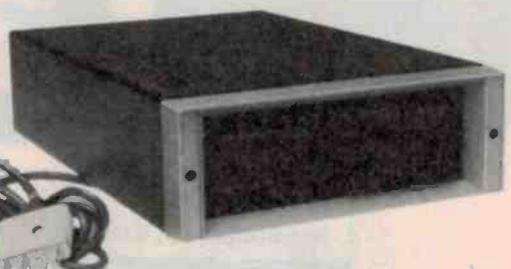

What a friend to have on your network!

RACAL

**Racal-Milgo
Australia Pty Ltd**

Head Office
47 Talavera Road North Ryde NSW
Australia 2113 Telex: 20365
Tel: (02) 888 6444

This is just the tip of the iceberg. We have a huge range of modems and MUX's from which you can make your selection, whatever your needs. Isn't it time you met some new friends? Give us a call and we'll arrange an introduction for you.

Branches:
Melbourne (03) 699 2133
Brisbane (07) 393 0699
Perth (09) 331 1199
Canberra (065) 47 9621

You can bank on the Bee!

Information Window to the World

Microbee brings direct low cost communications to Schools, Homes and Businesses through a number of emerging facilities worldwide. With the addition of the Telecom approved beemodem, any microbee becomes your information window to the world.

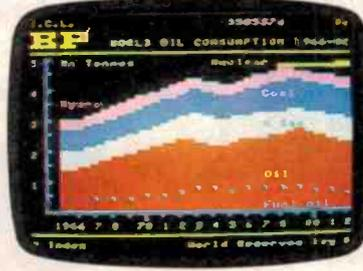
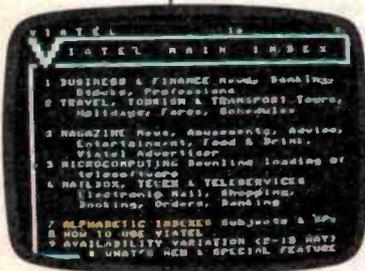

The beemodem operates at 300 or 1200/75 BAUD.
beemodem . . . \$189.50

Austpac Telecom's X25 Revolution

Austpac opens the gateway to the world of data transmission, offering organisations and individuals a window to the world of computer communications and data base access, heralding a giant leap forward in telecommunications. Networks, a buzz word of not long ago are now a reality. Telecom's Viatel Gateway now links microbee's in Homes, Businesses and Schools with Viatel Service Providers, offering services, information and goods as many as they are varied. The communications horizon has indeed increased for microbee users.

The microbee/Viatel Option

Viatel, Telecom's exciting new interactive videotext system is now in full operation and even more exciting, it's available on the microbee, Australia's own Educational, Home and Business Computer.

The Viatel Option is a hardware/software modification for any microbee, that used in conjunction with a 1200/75 BAUD beemodem will bring information, banking, news, weather reports, software and much, much more into your school, home or business for not much more than the cost of a local phone call . . . Microbee/Viatel Option . . . \$49.50

Instant Access to Information

By utilising the existing telephone network, Viatel gives domestic and business users instant access to



information and services available through the central Viatel computer.

Information is received through your microbee personal computer fitted with the Viatel Option. You can even have a printer connected to your microbee.

So Simple to Use

Press a key on your microbee and you enter the Viatel system. Enter your personal password and you get the index. From here you can call up information from hundreds of different sources and see it displayed on your screen. It's that simple.

A registered Viatel user can enter the system from anywhere in Australia for the cost of a local phone call. 24 hours a day. All you need is your password and in most instances, a standard telephone service.

A Two-Way System

Telecom Viatel does more than just provide you with information. It also lets you act on it. Imagine the convenience of being able to place orders, confirm bookings . . . even make payments through the system. And you're not limited to communicating just with the people who provide the information. You can also send messages to other Viatel users. And remember, with Viatel, all your communications are instant and confidential.

Bank on the Bee

You can bank, shop, learn and exchange ideas on a microbee, fitted with the Viatel Option. What's more, you can first store, then retrieve a number of screens of information for use later when off-line. This particular feature will prove a real boon to those monitoring exchange rates, weather patterns, stocks and commodity prices.

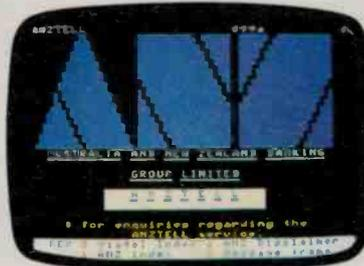

Electronic Mail

Already in use in Western Australian Schools, microbee's with beemodems are linking together in information exchanges and speeding up inter school communications.



Designed and manufactured in Australia by Applied Technology

microbee

PHONE ORDERS
ACCEPTED

microbee technology centres

- N.S.W. 1 Pattison Ave, Waitara 2077 Phone (02) 487 2711 - 2/956 Hunter St, Newcastle West 2302 Phone (049) 61 1090
- VIC. 50-52 Whitehorse Rd, Deepdene 3103 Phone (03) 819 5288
- W.A. 141 Stirling Highway, Nedlands Phone (09) 386 8289
- S.A. 117-119 Gouger St., Adelaide 5000 Phone (08) 212 3299
- QLD. 455 Logan Rd, Stones Corner 4120 Phone (07) 394 3688
- FACTORY Koala Crescent, West Gosford 2250 Phone (043) 24 2711 — microbee educational technology centre • Unit 2, Eden Park Industrial Estate, 31 Waterloo Rd, North Ryde 2113 Phone (02) 888 9940.



How business can make the Telecom Network work even harder.

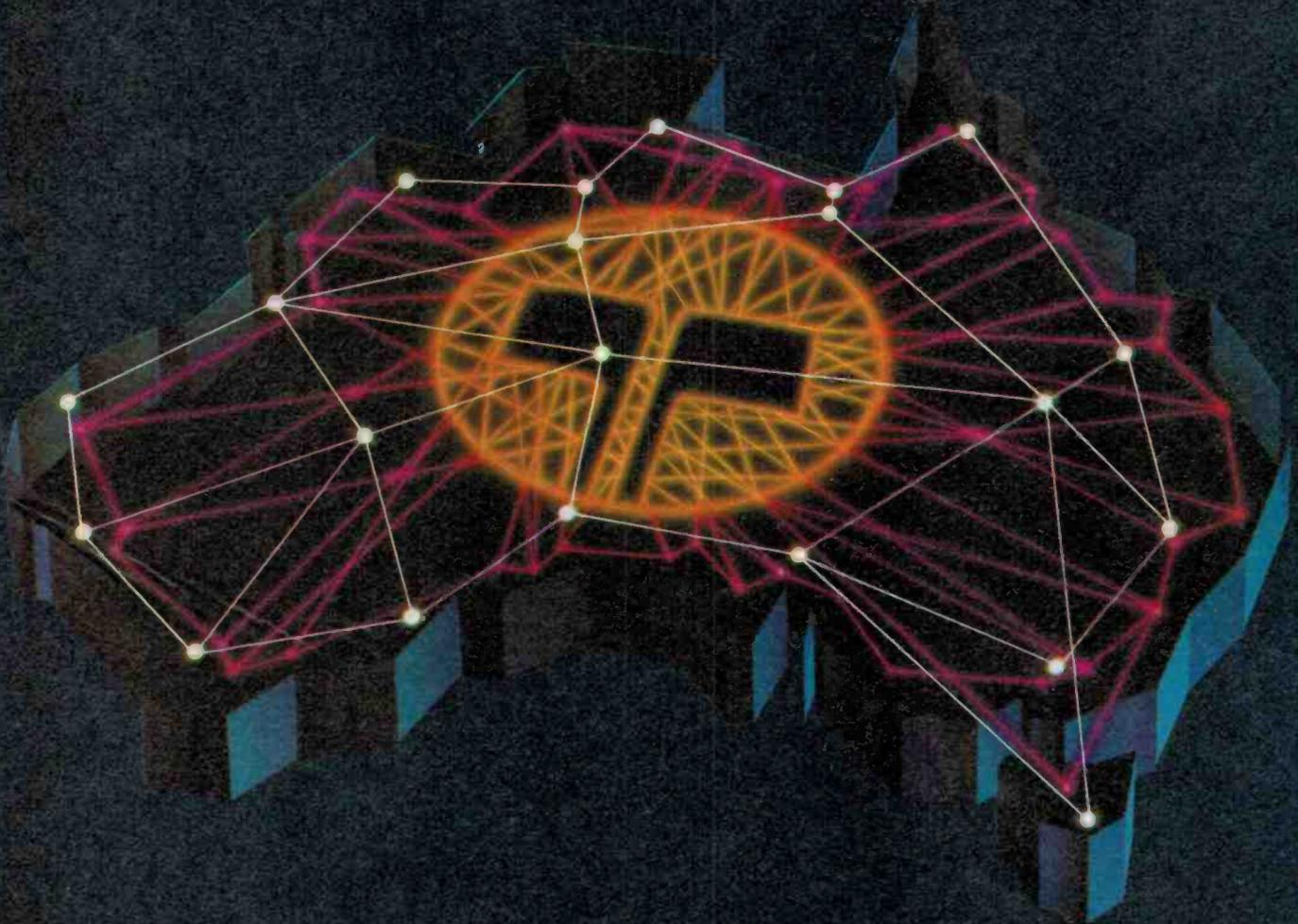

The Telecom network is one of Australia's most precious assets. Every day channelling 30 million messages throughout the land. Yet still capable of helping both large and small businesses even further.

By opening new markets at minimal expense through the use of 008 and STD. By transmitting masses of text and data as well as verbal messages. By providing written communications through Telex or, wherever there's a phone,

through Telememo and now through ComputerPhone. And in keeping business on the move with radio paging and mobile phones.

So why not call your business consultant on 008 011 311* for the cost of a local call and start making the network work even harder for your business.

*In Tasmania call 31 4888.



Telecom Australia
Better for Business

THE 8 mm VIDEO CHALLENGE

— Sony Video 8 Model CCD-V8

Louis Challis

Three technical breakthroughs have enabled Sony to produce a featherweight contender that may well prove a winner over the heavier half-inch camera/recorders that until now have dominated the video camera/recorder market.

ANYBODY WHO HAS ever attempted to use a battery operated video recorder in the field (or at home) will tell you what a thankless task this becomes after you have held the recorder on your shoulder for more than a few minutes. Even with the best ergonomically designed shoulder rests, the weight, quite apart from the constriction of your hand muscles, makes you wish you had never contemplated the task!

Obviously, the availability of a tripod solves that problem, but it usually creates a new one because you immediately lose the mobility and flexibility that a hand-held, shoulder-mounted video recorder can provide. Nowhere is this more evident than in the field of news gathering where the TV station news crews have to run around in situations that are often complex or dangerous, carrying their modern generation 'balls and chains' on their shoulders and backs.

Sony Corporation (and most of its competitors) are well aware of this problem, which has tended to discourage many budding cameramen (and women) from enter-

ing the wonderful world of home and sports video.

The release of the Sony CCD-V8 8 mm video camera/recorder (camcorder) is unquestionably the 1985 breakthrough that most of us have been waiting for. Sony has in one bold step produced an unbelievably lightweight, integrated camera/recorder that solves most of the problems which previous generations of heavy and large video cameras and recorders had created.

Three fundamental technical problems had to be overcome to create this delightful piece of equipment. The first 'breakthrough' related to the camera itself, where the optical signal has to be converted into an electrical signal with adequate resolution. An alternative approach had to be found for the heavy and large camera tubes which were a feature of the previous equipment. Sony has developed a highly efficient charge coupled device (CCD) image sensor which is so small and so sensitive that it works happily

down to a 22 lux illumination level.

The second breakthrough was the development of a new 'industry standard' compact video cassette, physical size of which is comparable to the standard 'compact audio cassette', is only a quarter of the volume of a standard Beta format cassette and is proportionally smaller than a standard VHS format cassette. These compact video cassettes are called '8 mm video' or 'Video 8', based on the 8 mm wide tape. They have a metal-coated format which achieves high modulation levels, wide dynamic range and twice the recording density of conventional 12.5 mm (half inch) video tape. The tape formulation Sony has developed incorporates ultrafine metal particles whose individual length and dimensions give a volume of less than 1/25 of that associated with conventional videotape magnetic material. The metal particles also give a higher coercivity and better retentivity, together with the ability to record at higher frequencies, ▶

SONY VIDEO 8 MODEL CCD-V8

Dimensions:	Approx 117 mm (wide) x 193 mm (high) x 344 mm (deep)
Weight:	Approx 2.3 kg (including battery and cassette)
RRP:	\$2199



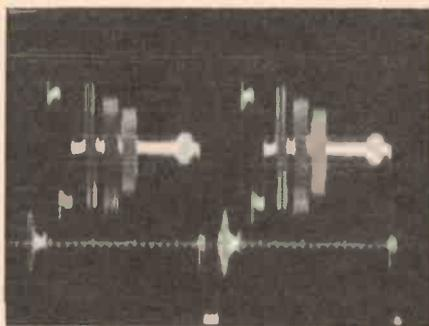
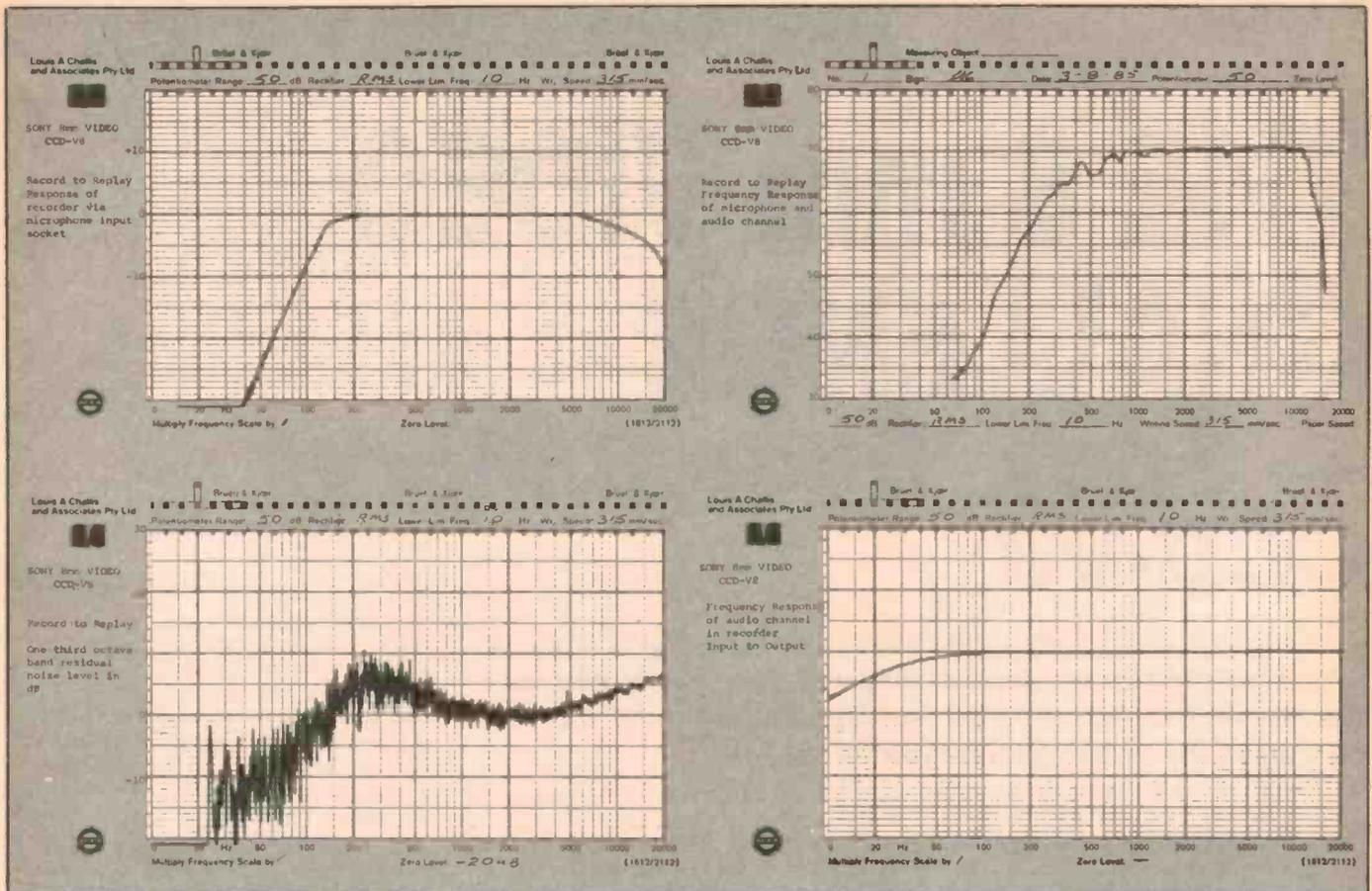

Multi-burst frequency response display.

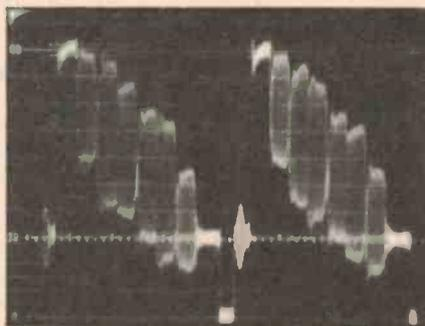

Colour burst linearity performance.

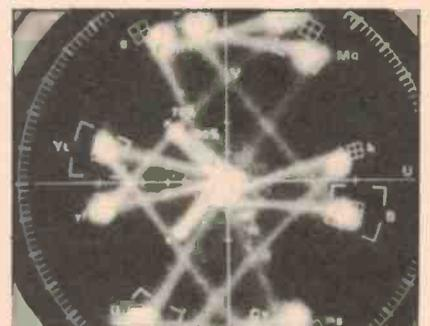

Vector scope colour balance display.

which becomes a critical requirement in the system.

The 8 mm video cassette tapes look different from the ordinary compact cassette tapes because, as well as incorporating superior magnetic properties, they have been developed with enhanced binder systems; the surface is super-polished by a new calendaring technology which provides a mirror smooth surface to reduce the likelihood of recording head contamination and, even more critical, recording head wear. As a final touch, the tape is 'back coated' to improve the tracking of the drive system, which has twice the demands placed on it as a half-inch VCR tape format. The tapes also incorporate a new automatic tape recognition system based on the concepts (but different in precise detail) of those developed

for the audio compact cassette.

The third breakthrough concerned miniaturisation, with Sony once again achieving a level of sophisticated miniaturisation for which it has become famous and universally respected.

The most critical aspects of this miniaturisation are readily evident in the video recorder section of the integrated package, which provides all the versatility expected in a conventional full-sized video recorder in a package only slightly larger than the audio cassette recorder you are currently using at home or in the office.

Design

The Sony Video 8 integrated video camera/recorder comes in a neat package, the working part of which is covered by a

slip-on plastic cover which provides protection for both the lens assembly and the plug-in cardioid microphone located immediately above the zoom lens. With the cover removed the small zoom lens assembly, with its 1:1.14 aperture covering 12-72 mm focal length and its ability to focus from 1.1 m to infinity is clearly seen. The working end of the lens has both a roll-out rubber hood, which can be simply pushed back to save space, and a clip-on lens cover with central white plastic diaphragm to provide simplified white balance adjustment.

The microphone is a 12 mm diameter plug-in cardioid assembly with simple bayonet fitting, double plug connections for power and signal, and an integral foam plastic windscreen cover providing both mechanical vibration isolation and reasonable

outdoor wind protection.

The major controls for the camera are located on the left hand side of the body and are limited to a three position 'white balance' control — for sunlight, incandescent light and automatic. Adjacent is a power ON switch coupled to an internal timer that switches the unit off to conserve battery power if the unit is inadvertently left on for more than five minutes without filming. Below this switch are two others which set the amount of light entering the camera with a normal CENTRE position; a BACK-LIGHT position when the subject has the illumination behind it, and a HIGHLIGHT position to adjust the illumination level when the subject is more brightly lit than the background. The remaining switch in this grouping is the RECOARD REVIEW switch which allows the operator to review the last few seconds of filming when the recorder is set in the pause mode.

At the top of the camera an adjustable horizontal shoe is provided to connect the model VF-206 viewfinder, which is a small (20 mm x 15 mm) black and white video display with mirrors, adjustable focusing lens and eye hood through which accurate focusing can be achieved.

The viewfinder also allows you to view the filming as you record it (or afterwards) and contains three separate indicator lights. The first of these is a yellow light which indicates that there is inadequate light level for recording. The second is a red light which is steady during recording but blinks when the battery voltage is too low, when the tape is at the end or when a pre-recorded tape with tabs removed has been inserted in the recorder. The third light, which is orange, glows steadily when the white balance switch is functioning correctly in sunlight or illuminated light and blinks when the balance is incorrect.

The viewfinder is universally adjustable to suit different sizes of human head but is only suitable for viewing with the camera mounted on the right shoulder and the controls operated by the right hand. When mounted on a tripod it can be rotated to suit the requirements of a left-handed person, if desired.

Located on the right hand side of the unit is a bulbous container with a covered hand-strap, designed for gripping and conveniently holding the camera/recorder on your right shoulder. The front of the container has a neat inward hinging 'trap-door' which will accept either of two different power supply units (both of which are supplied). The first is a mains power supply cartridge to which a 2 m long mains lead is connected. This cartridge provides 8.5 volts at 1 amp and, in conjunction with a neat little adaptor (model BCA-85), doubles as a battery charger for the battery pack supplied with the unit. The battery pack (NP-22), after charging, provides 6 volts at 1.3 amps and is capable of powering the unit for up to 30 minutes of recording. A serious user would be well advised to buy a second battery pack (or even more) if long-term outdoor recording is contemplated. On top of

the power supply container is a wide angled/telephoto rocker switch control, and at the rear there is a single RECORDING START/STOP button.

Immediately behind the power supply container is the cassette well into which you may insert one of three different sizes of Sony (or other) 8 mm video tapes; these are the P30, P60 and P90 lengths which provide 30, 60 and 90 minutes respectively of recording at standard speed and double that time in the long play (LP) mode.

The opening of the cassette well is fully automatic, controlled by the EJECT button. It can be closed with or without a cassette inside by pushing down on the lid.

The control panel on the rear of the recorder is relatively conventional. On the top left hand side there's a VTR pushbutton for powering up the video recorder section without turning on the camera. To the right of this is the liquid crystal display providing information on moisture content within the unit, battery level if the battery supply is exhausted, four digit tape counter, MEMORY function and a tape indicator which shows that the cassette has come to an end, the tab has been removed or the recorder is in the camera mode. Immediately below this are three pushbuttons: a RESET button to put the counter back to zero, a MEMORY button to spool back to '0000' in the FAST FORWARD or REWIND modes, and an INSERT button to insert footage onto a section of previously recorded tape. To the top right is a switch for STANDARD play or LP which allows normal or half-speed video recording. Below it is a 5-pin remote control socket to accept the wired remote control unit.

On the bottom of the panel is a red slide record switch and lamp which allows you to make video recordings when only the recorder section is turned on. The red light then glows and you are able to use the five normal buttons of PLAY, FAST FORWARD and REWIND, STOP and PAUSE located on the bottom of the panel. Last but not least, an ear socket is provided through which you can monitor the quality of the sound being recorded on the tape during camera or insert recording and during playback.

A removable cover on the bottom of the unit conceals a 24-pin socket which accepts the Sony RFU-85 adaptor. This conveniently provides the full spectrum of connectors for video input and output, as well as audio input and output using RCA coaxial sockets, together with rf output to feed to a conventional TV set. The adaptor has adjustments for optimum viewing on UHF video channels 30 through 39 and a switch to facilitate correct viewing with video channel spacings required in European or other PAL systems.

The unit also comes equipped with a video editing controller (RM-E100V) which

allows you to control an 8 mm video format camera/recorder together with another video camera recorder or VTR, either simultaneously or individually, to perform a wide range of tape-to-tape editing procedures. It enables you to assemble, memorise and automatically edit up to eight separate segments of programme in any desired sequence, simply by pressing a button. The unit also provides the facility to rehearse 'or preview' the playback procedure before the actual editing takes place.

Objective testing

The objective testing of the recorder was firstly devoted to an assessment of the video characteristics of the camera when feeding either directly to line or through to the video recorder for subsequent replay. The first series of laboratory assessments aimed at determining the video resolution and bandwidths of the viewfinder and its focusing accuracy. It confirmed that the viewfinder has a resolution of at least 300 lines and a resolution to 4.8 MHz when provided with multi-bursts from a CCIR standard multi-burst signal generator. The multi-burst generator provided signals at 0.5, 1.0, 2.0, 4.0, 4.8 and 5.8 MHz. The multi-burst signals confirmed that the video recorder offers good linear response to beyond 2.3 MHz with a substantial reduction in signal up to the chrominance sub-carrier frequency, at which it is still acceptable.

The replay linearity was checked on the Marconi (BBC resolution chart no 1) and confirmed that the resolution of the optical system plus CCD detector is better than 270 lines on replay and just exceeds 280 lines on direct monitoring.

The colour balance response was assessed with a Tektronix 521A PAL Vectorscope which confirmed that the colour balance of the unit is extremely good and substantially better than the majority of conventional VHS and Beta format video tape recorders that we have recently assessed. The signal-to-noise characteristics of the recorder were assessed over the range 40 Hz to 10 MHz. With the sub-carrier trap on, the noise figure was -36 dB re 1 volt rms output from the camera. With the sub-carrier trap in the IN position (ie, no information at 4.43 MHz) and with the video weighting filter on, this improved to -36.4 dB rms whilst the luminance noise figure was -40.2 dB and the chrominance figure was -46.6 dB.

The colour balance was also checked using a Sony Profeel colour monitor and confirmed that the colour balance with a Technics colour bar pattern provided excellent colour fidelity as did the standard colour burst signal.

The evaluation of the audio frequency response of the video recorder presented a number of practical, and what initially appeared to be almost intractable, problems. ▶

SIGHT AND SOUND REVIEW

MEASURED PERFORMANCE OF SONY VIDEO 8 CCD-V8 VIDEO CAMERA RECORDER

Serial No. 203413

VIDEO PERFORMANCE

Luminance bandwidth	2.3 MHz
Step Response linearity	better than 3%
Chrominance response	above average
Chrominance linearity	above average
Video resolution	280 lines
Linearity at 50% luminance	above average
Video gain	adequate
Signal to noise and noise figure with sub-carrier trap on	40 Hz to 10 MHz re 1 volt rms -36 dB rms
with video weighting figure on	-36.4 dB rms
Luminance noise figure	-40.2 dB
Chrominance noise figure	-46.6 dB

AUDIO PERFORMANCE

	Record to Replay frequency response
Microphone input	600 Hz to 12.3 kHz - +1 -3 dB
Electrical input	126 Hz to 12.3 kHz - +0 -3 dB
Internal amplifier	23 Hz to 20 kHz - +0 -3 dB

DYNAMIC RANGE Greater than 70 dB(A)

NOISE THRESHOLD 14 dB(A) re 20 micropascals

ERASURE RATIO

(for 1 kHz signal recorded at 0 VU)

Tape:- Sony P5-30 Greater than 90 dB

MEASURED WOW & FLUTTER

0.02 %

These problems arose because of the fundamental design of the video recorder which works on the principle that the user should not be given control of the audio channel recording level and consequently does not require any read-out or indication of modulation level or overload.

Our consequent approach was to place the video recorder in our anechoic room to measure the frequency response of the microphone when fed by our reciprocity microphone calibration system. These measurements revealed that the frequency response is essentially flat from 600 Hz to 12.3 kHz (+1 -3 dB). The frequency response at the input socket is far flatter being 126 Hz to 12.3 kHz (+0 -3 dB) whilst the internal electronics of the audio channel has a frequency response which extends from 22 Hz to beyond 20 kHz.

The handbook and manufacturer's literature make no mention of these characteristics nor of the reasons underlying this approach. I suspect that the low frequency response has been deliberately rolled-over to reduce the impact of traffic noise, wind noise and room modes which would otherwise detract from the quality of the sound. Remember, normal speech extends from

approximately 300 Hz to 8 kHz and would be faithfully reproduced by the recorder.

The next series of measurements that was recorded aimed at determining the lower sound level threshold of the audio channel and corresponded to 14 dB(A) and 17 dB unweighted. A signal threshold this low is extremely good and has obviously been achieved only at the expense of the low frequency response.

The maximum audio recording level of the unit exceeds 90 dB(A), resulting in an effective dynamic range in excess of 70 dB. With a dynamic range as great as this, it is no wonder that Sony has discarded the normal volume control or AVC circuitry that would otherwise have been essential.

Subjective testing

When you start using the CCD-V8 camera/recorder the first thing you are aware of is how well balanced the design is when either held in the hand or placed on your shoulder, or indeed even when placed on a simple video tripod. The unit is so easy to set-up, easy to record with and so easy to replay that first qualms about producing reasonable (or above average) footage are soon dispelled. It is as though the designers

understood your limitations and have produced a unit specifically for you. On replay I experienced fewer problems and a much more rapid familiarisation period than I recall with any other video recorder I have used. The plug-in rf adaptor unit (type RFU-85) is an absolute delight in use, providing rapid and convenient connection to either a video recorder or a conventional TV set.

The quality of video produced is almost as good as any I have seen recorded with a 'general consumer' oriented product. The 22 lux sensitivity of the CCD image sensor is not as high as that offered by some other new video cameras and recorders which are either larger or heavier. In practical terms, I did not find that this sensitivity limited my ability to use the recorder in low light situations or inside my house.

However, one limitation of the Video 8 system will soon become apparent if you wish to slow down sporting scenes, like football matches or swimming races. To achieve this you will have to resort to the use of one of the latest generation Sony Beta system recorders or a competing VHS VTR which offers 'super still' and almost perfect slow motion capabilities. Alternatively, the lack of that capability need not present any real problems because, as Sony points out, it is a primary design intention that such material when recorded on the Video 8 format is readily capable of being transferred to one of the alternative formats. This can be achieved during normal editing, after replay with a conventional video tape recorder (VTR) in any of the available formats.

I took some footage recorded with the CCD-V8 and replayed it through an older generation Sanyo VCR and found that there was no perceptible difference in the quality of the signal, provided I used a quality video tape (L-500 UHG). The audible quality of speech differed almost imperceptibly and the effective noise figure increased by less than 2 dB.

The Sony CCD-V8 Video 8 recorder enlarges the market for portable video recorders — a market that is already stronger and larger than most people realise. It does this by reducing the potential buyer resistance created by the heavier and bulkier machines which in plain English may be described as a 'real drag'. With portable videos already accounting for something in excess of 8 per cent of the Australian market I am convinced that sales will grow even larger when the convenience and flexibility of this particular product is fully recognised. It is undoubtedly the product sought by potential purchasers who want real convenience coupled with excellent performance. ●

Absolute copyright in this review and accompanying measurements is owned by Electronics Today International. Under no circumstances may any review or part thereof be reprinted or incorporated in any reprint or used in any advertising or promotion without the express written agreement of the Managing Editor.

Video 8

Video 8. It's the biggest thing to happen to video in a decade.

And the smallest.

The biggest thing to happen to video in years is incredibly small. In fact, it's only 8mm.

This new VIDEO 8 format has been agreed upon by 127* of the world's leading video-related companies.

BIG PERFORMANCE. Sony's VIDEO 8 camera recorder, the CCD-V8, is a sophisticated video recorder and camera in the same miniature package weighing only 2kg.

It allows you to shoot and record up to three hours on a single VIDEO 8 cassette, and play back on its detachable viewfinder or any television or monitor. As well, it offers all the features you'd expect from a full-size video recorder, even off-air recording with its optional tuner.

When shooting, an innovative new kind of erase head enables smooth, professional-looking edits in the camera, automatically.

SMALL SIZE. The cassette it uses is about the same size as your everyday cassette, yet, because of the new and greatly enhanced type of tape it uses, its picture quality rivals that of many half-inch systems.



And because VIDEO 8 employs the same FM audio recording method as hi-fi video recorders, its sound quality is probably superior to what you're using now.

COMPLETELY COMPATIBLE. This milestone in miniaturisation has been designed from the ground up to complement your existing video system. Whatever format you currently use, Sony's new VIDEO 8 works side by side as the most portable, most flexible, most extraordinary home video system ever conceived.

TOTALLY UNIQUE. Sony's new VIDEO 8 camera recorder, the CCD-V8, is like no other system you've seen before. It has so many unexpected and sophisticated features that you will immediately recognise it as the biggest thing to happen to video in a decade.

It's also the smallest.

SONY®

Recording of TV programmes is not permitted unless permission is granted by the copyright owner. *As at February 1985.

VID 0617/C

BIG CHOICE ART UNION

No. 132

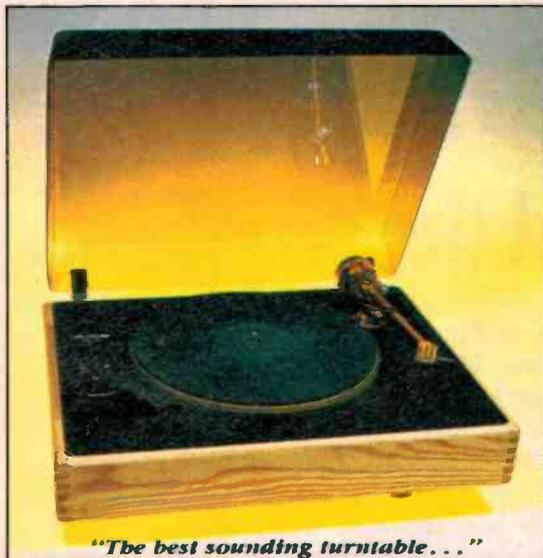

"The best sounding turntable..."

SOTA SAPPHIRE TURNTABLE

THIS TURNTABLE WILL TURN YOUR HEAD — AND IS ONLY PART OF A FABULOUS \$35,000 PACKAGE OF HI-FI EQUIPMENT which includes SOTA Sapphire turntable, mod squad triplaner tunearm, hybrid tube and transistor pre amp, 250 Watt power amp for driving bass speakers, Vandersteen Speakers. (Value \$35,000) also included is an IBM AT Personal Computer, Blackfin 24 Power Boat and a Qualtrovalvole FERRARI.

To summarize, the winning ticket holder receives superb Hi-Fi equipment (value \$35,000) plus an IBM AT Personal Computer with Software (value \$15,000) plus a Blackfin 24 Express Centre Cabin Power Boat with full electronic fit out (value \$50,000) plus a GTS 308 Qualtrovalvole FERRARI (value \$80,000).

TOTAL VALUE \$180,000

BIG CHOICE ART UNION NO. 132 DRAWN 8TH NOVEMBER, 1985.

Choose this as your \$180,000 first prize or select from these alternatives:

A Silver Spirit Rolls Royce (\$161,000) plus a \$19,000 diamond pendant OR
A Mack Ultraliner (Model MHR 613R) or a Mack Superliner (Model 721RS) both with extras OR

A Cuddles "35", plus a Cuddles "30" Cruiser with luxurious extras OR

A GTS 308 Qualtrovalvole Ferrari (\$80,300) plus a Haines Hunter 850 FBC Cruiser with dual Volvo 6 cyl. turbo motors (\$89,700) plus a \$10,000 diamond pendant OR

A John Deere 8850 Tractor with a John Deere 1610 Chisel Plough or Cultivator (\$177,000) plus a Honda 4 wheel TRX250 (\$3,000) OR

A fully furnished 4 bedroom Gold Coast home a 162 Burleigh St, Burleigh Waters (\$175,000) plus a diamond pendant (\$5,000) OR

A "Round Australia" package including a Range Rover, Viscount caravan, 2 trail bikes, camera equipment, \$10,000 of Flag Inns accommodation and services, a Ford Fairlane, camping equipment, diamond pendant, and a Haines Hunter Cabin Cruiser.

Each of these prizes valued at **\$180,000**

Tickets in the Art Union are just \$5.00 each.

BOOK BUYERS PRIZES

\$10 Book

Choose from: A Ford Spectron XLT OR a BMW K100 motorcycle with extras OR a Mitsubishi L300 4WD Wagon OR Ford Falcon GL Sedan OR a diamond pendant

Each valued at \$15,000

\$20 Book

Choose from: A Nissan Patrol 4WD Wagon OR a Haines Hunter 19' 4" Cabin Cruiser with 140 h.p. Johnson outboard with Roll-Ezy trailer OR a Ford Fairmont 4.1 EFI T-Bar Auto. Sedan (with extras) OR or a diamond pendant

Each valued at \$20,000

\$40 Book

Choose from: A Ford Fairlane plus a \$2,000 diamond pendant OR a 19' 6" Haines Hunter Cabin Cruiser with a 185 h.p. Johnson outboard with Roll-Ezy trailer and extras OR a 12.2 metre Haulmark tri-axle semi-trailer complete with gate sides, with cap tarp and side curtains and 6-15RX22.5 wide profile tyres

Each valued at \$26,000

\$50 Book

A Citroen CX25 GTI 2500 plus a \$3,000 diamond pendant OR the new magnificent Renault 25 automatic saloon PLUS a \$4,000 diamond pendant OR a 4 door Range Rover (with extras) OR an LTD Luxury Saloon (with extras) OR a 21' Haines Hunter Cabin Cruiser with 260 h.p. Merc Cruiser stern drive with extras on a Roll-Ezy trailer

Each valued at \$40,000

IN AID OF MARIST BROTHERS SCHOOLS AND PROJECTS AND SPORTING WHEELIES DISABLED SPORTS ASSOCIATION OF QUEENSLAND

For further information regarding prizes, or if the ticket order form has been detached, contact The Big Choice Art Union, 82 Moola Road, Ashgrove, QLD 4060. Phone (07) 38 4134

Permit No. A7390

A.C.T. Permit No. 85/287

KITS

Lotsa bits to test your wits!

Now RTTY too! Yes, you can now display Radio Teletype on your Cat Computer or display facsimile (FAX) weather pictures on your printer. This amazing DSE kit has a higher resolution than anything else at the price so you get sharper more detailed pictures than you'd think possible! Power comes from your computer so there's no need for separate supplies! Has a Serial TTL compatible output, operates at 1600Hz and 2400Hz and Fax synchronization is crystal locked! Cat K-6335



FAX & RTTY FOR THE CAT COMPUTER

VALUE **\$79⁹⁵**
AT ONLY

As described in ETI

Two Great Mosfet Amps



Wow! Now you can have a 60W or 100W Mosfet module amp at a fraction of the cost of a commercially produced unit.

These high performance general purpose amp kits are intended for use in a wide variety of applications and offer performance, reliability and versatility at an incredible price.

The design of the modules makes them suitable for a wide range of standard low-cost chassis. These are high performance modules at a price that's hard to beat!

SPECIFICATIONS:

- Power Output: Max — 100W RMS
- Frequency Response: Flat within +/- 0.4dB from 8 Hz to 20kHz
- Input Sensitivity: 1.2V RMS for 100W out
- Noise: - 100dB below full output
- Intermodulation Distortion: 0.003% at 100W (50Hz & 7kHz mixed 4:1)
- Stability: Unconditionally stable.

60 Watt Mosfet \$49
Cat K-3441
100 Watt Mosfet \$69
Cat K-3443

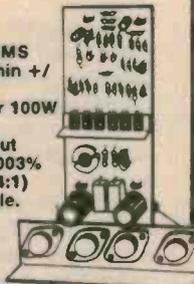

Shortwave Antenna \$16⁹⁵

Your expensive receiver isn't worth much if your antenna's a piece of string! Get the best reception from your equipment with this high quality short wave antenna.

It was designed by a shortwave expert just for DSE and it's complete and ready to assemble — without any soldering! Comes with full instructions. It's great value! Cat K-3490

I/R Remote Repeater

As described in AEM.

You're in bed, the video's started and finally you can relax. Oh no! The telephones at it again and you drag yourself into the lounge to stop the tape. Now it couldn't be easier with the I/R Remote repeater. With this easy to assemble kit you can have the convenience of your Infra-red remote controller from any room in the house. Cat K-3426



VALUE!
\$34⁵⁰

Build a Teletext? Remote is easy

\$49⁹⁵

As described in EA



Why move when you can do it from your chair? With the TELETEXT Infra-red Remote Control you'll have it all at your fingertips.

It's easy to build and the transmitter's a compact hand held unit while the receiver fits into your Teletext decoder (K-6315)

Make life easy for yourself — with everything at your finger tips! Cat K-3425

VZ Serial Interface



Now you can have all the hardware and software necessary to emulate a simple 300 Baud terminal with full or half duplex operation for your VZ series computer. Suits VZ200 & VZ300.

It allows you to connect a modem and get your VZ on the line. Even has a print echo so you can record the conversations!

The kit is easy to build and fits inside a VZ expansion case so you get a professional finish at a low DSE price! Cat K-6317

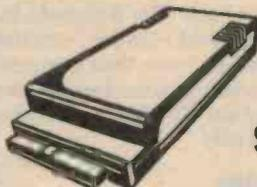

As described in ETI

BARGAIN!
\$49⁹⁵



200 Watt Playmaster

BUILD & SAVE

As described in EA

Wow! Quality, performance, reliability, an incredible 200 watts and a DSE low price!

The Playmaster 200 Hi Fi Mosfet Amplifier is just incredible value! It's so advanced you'd wonder why anyone with a soldering iron would buy anything else.

Just look! *100W/channel *Freq. Res. 8Hz-20kHz (-0.3db) — 2.8Hz-65kHz (-1dB) *RIAA equalisation within 0.3dB *Distortion <0.01% max (typical — 0.003%) 20Hz - 20kHz * And much much more! Cat K-3516

GREAT VALUE! **\$439**

Beat Triggered Strobe

ONLY **\$59**



As described in AEM

A flasher's guaranteed to put some life into any party! An now you can have one of your own. A beat triggered strobe that comes complete with case, reflector, PCB, everything! It's so simple to build and has adjustable sensitivity. Don't let your party flop when you can get it rocking in a flash! Cat K-3153

DICK SMITH ELECTRONICS

TOP SOUND, BUDGET PRICE

— the Yamaha A-320 amplifier

By removing the tone controls and associated circuitry, Yamaha has come up with a budget priced amplifier — without compromising on the quality of sound.

Louis Challis

DURING THE LAST year I have reviewed a number of amplifiers in which the designers have broken with tradition and deleted tone controls from the front panels of the pre-amplifiers or integrated amplifiers. One of the most interesting of these products was the Perreux SM2 pre-amplifier, which performs outstandingly; both the ME 15 and the QED A230 which I reviewed follow the same trend. Even the illustrious firm of NAD in America now subscribes to the same concept, suggesting a new 'ground swell' of public demand and general acceptance of this 'no frills' concept.

I would guess that 90 per cent of owners seldom, if ever, use their tone controls so there is either no adjustment from the centre indent position or at best a fixed adjustment of the treble or bass controls to account for inadequacies in the loudspeakers or in the listening environment. Obviously, tone controls add significantly to the cost of a pre-amplifier or an integrated amplifier; consequently in the world of marketing there are great advantages to be gained through the deletion of any possible unwanted components.

The circuit designers at the Yamaha factory in Hamamatsu, Japan, are unquestionably among the best in their country and they have impressed me with the superb quality in their top of the line pre-amplifiers and amplifiers. When I visited this factory late last year, I was able to see at first-hand how the designers achieved the quality in their products, and to inspect one of their production and research facilities. As a result of that visit I have a much better appreciation of what they 'are all about'.

It came as no surprise to hear that they

too had decided to develop and market a 'no frills' amplifier aimed at the lower end of the market where they would compromise nothing by the deletion of the tone controls and the associated circuitry. What Yamaha decided to market was an amplifier in which the dynamic range, signal-to-noise ratio and inherent distortion characteristics were "one order of magnitude better than either their previous products or their competitors' products".

By reducing the number of components in the front end it should be readily possible to improve the overall signal-to-noise ratio as well as to improve overall amplifier stability. By removing a significant number of unwanted components, total stability should be enhanced and special purpose integrated circuits could then be developed to meet the special needs of this unit (and subsequent derivatives). The designers assured me that this would result in "a better amplifier which would leave their competitors reeling" in much the same way that the release of the Yamaha CD-X1 compact disc player did in mid-1984.

Design details

The A-320 amplifier has a conservative black front panel which is deceptively 'bland'. The brushed black anodised aluminium front panel uses light grey silk-screened lettering to create a subdued image that may well appeal. On the left hand side of the panel is a large rectangular power ON/OFF switch flanked by a small elongated red LED. Immediately below this is a standard 6.5 mm tip ring and sleeve headphone socket.

On the other side of the front panel are

The amplifier is constructed on a very strong, well ventilated steel chassis with a matching perforated slotted steel lid ensuring adequate cooling under almost all reasonable conditions. The rear of the amplifier incorporates six pairs of RCA coaxial sockets, two of which (for the phono sockets) are gold flashed; the other two groups of tape recorder input and output sockets are sensibly grouped together. The designers have taken more trouble than usual with the speaker terminals, which use spring-loaded terminals with oxygen-free copper wiring to further enhance the low resistance of the output circuitry. Apart from the colour coded speaker sockets and a screwed grounding terminal, the only other notable mechanically interlocked selector switches for TAPE MONITOR, VIDEO/AUXILIARY, CD, TUNER and PHONO. Above these five switches is a small black escutcheon behind which five separate large red LEDs are located. The switch that has been activated does not stay indented so the associated light is necessary to indicate which functional input has been selected. To the right of this is a pair of coaxial volume controls, the outer knob being used for the right channel and the inner being used for the left channel. Mechanical friction between the two knobs allows you to adjust the relationship and thereafter retain it without complication. The volume control appeared to be a little loose (and unsure of itself) and it subsequently transpired that the unit had apparently received a knock during shipment resulting in a loosening of the fixing screws. worthy feature on the back panel is the 2.4 m long double insulated mains lead

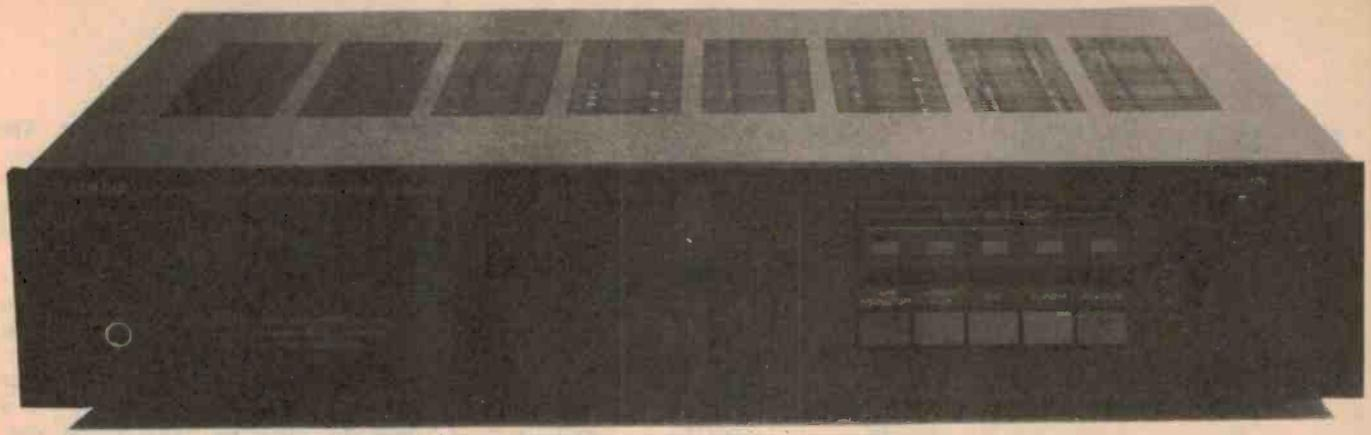

YAMAHA A-320 AMPLIFIER

Dimensions: 435 mm (wide) x 92 mm (high)
x 293 mm (deep)
Weight: 4.6 kg
Manufacturer: Nippon Gakki Co Ltd, Japan
RRP: \$299

which terminates in a two pin mains plug.

On opening the amplifier, my first impression was 'where have all the components gone?'. Although there are components including, it should be noted, an output protection circuit, Yamaha has achieved notable gains through the use of the same techniques that it applied so cleverly in its CD-X1 second generation CD player. The basis of those gains was on using new purpose designed ICs which literally replaced dozens (or even hundreds) of components with a single integrated circuit. In this case, the amplifier contains just three integrated circuits, three small low level signal transistors and four power output transistors to achieve superior performance to that offered by other amplifiers like the QED A230.

Inside the amplifier you can clearly see the space that has been allocated for fitting tone controls on the chassis as well as the spaces and holes for associated electric circuitry on the motherboard. The heatsink is a simple aluminium 'top hat' folded on the bottom of the heatsink with the individual leads soldered back into the motherboard below. The mains circuit of the amplifier is fused, while the output circuitry incorpo-

IEC HIGH FREQUENCY TOTAL DIFFERENCE FREQUENCY DISTORTION

YAMAHA A-320 STEREO AMPLIFIER

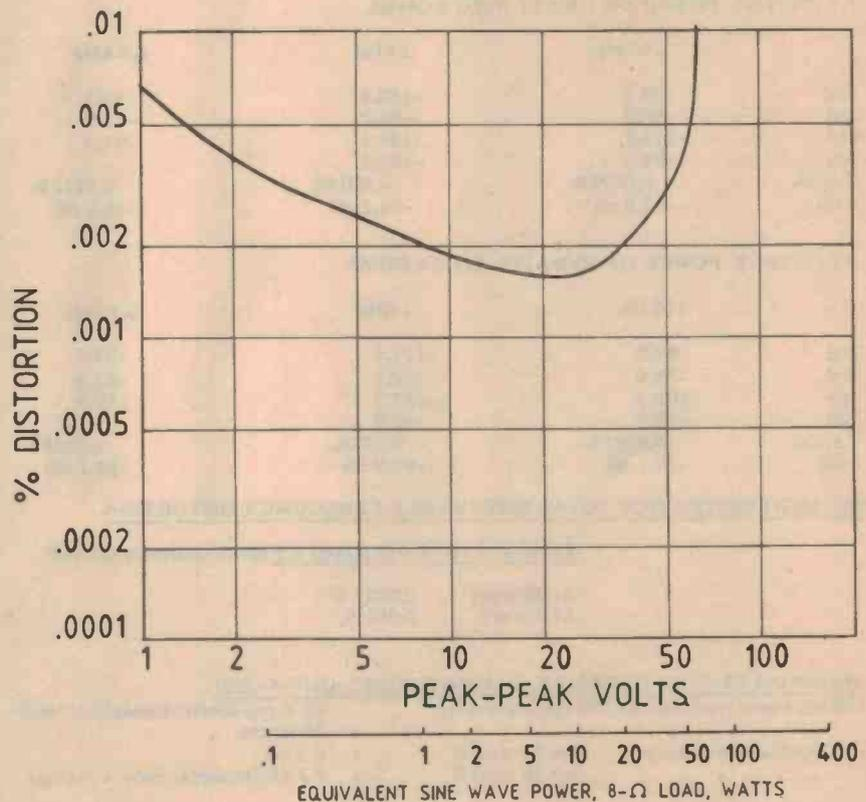

AMPLIFIER DATA SHEET

MEASURED PERFORMANCE OF : YAMAHA A-320

SERIAL NO : 100124

FREQUENCY RESPONSE (-3dB re 1 watt) :

Input to Aux = 0.5V	Tone Controls Defeated				
	Left	8.9 Hz	to	231 kHz	
	Right	8.6 Hz	to	217 kHz	

SENSITIVITY (for 1 watt in 8 Ohms) :

	Left	Right
CD	26.5 mV	26.5 mV
Auxiliary	26.5 mV	26.5 mV
Tuner	26.5 mV	26.5 mV
Tape	26.5 mV	26.5 mV
Phono	0.48 mV	0.48 mV
OVERLOAD	Phono 190 mV	190 mV

INPUT IMPEDANCE (@ 1kHz) :

	Left	Right
CD	45 k ohms	45 k ohms
Auxiliary	45 k ohms	45 k ohms
Tuner	45 k ohms	45 k ohms
Tape	45 k ohms	45 k ohms
Phono	45 k ohms	45 k ohms

OUTPUT IMPEDANCE (@ 1kHz) : 168 milliohms

NOISE & HUM LEVELS (re 1 watt in 8 ohms) :

Input 0.5 V					
Input 5 mV	Auxiliary	-74.5 dB(Lin)		-84 dB(A)	
	Phono	-72 dB(Lin)		-83 dB(A)	

HARMONIC DISTORTION :

AT OUTPUT POWER OF 1 WATT INTO 8 OHMS

	100 Hz	1 kHz	6.3 kHz
2nd	-99.6	-100.4	-92.1
3rd	-82.2	-96.2	-78.9
4th	-115.2	-107.1	-97.3
5th	-108.4	-105.3	-
T.H.D.	0.0078%	0.0019%	0.0117%
= dB	-82.0 dB	-94.2 dB	-78.6 dB

AT OUTPUT POWER OF 50 WATTS INTO 8 OHMS

	100 Hz	1 kHz	6.3 kHz
2nd	-84.8	-104.6	-93.1
3rd	-74.6	-82.6	-87.3
4th	-107.3	-107.3	-89.9
5th	-93.7	-90.5	-
T.H.D.	0.0197%	0.008%	0.0058%
= dB	-74.1 dB	-81.9 dB	-84.7 dB

IEC HIGH FREQUENCY TOTAL DIFFERENCE FREQUENCY DISTORTION

8 kHz and 11.95 kHz mixed 1:1 (both channels driven)

At 30 watt	0.0013 %
At 1 watt	0.001 %

MAXIMUM OUTPUT POWER AT CLIPPING POINT (IHF-A-202) :

(20 mS burst repeated at 500 mS intervals)	= 60 V p-p (both channels driven)
	= 56 watts
Dynamic Headroom (re 50 watts)	= 0.5 dB
(re 30 watts)	= 2.7 dB (manufacturer's rating)

rates an overload protection relay. The large and adequately sized power transformer is angled for minimum inductive pick up, and sports two large rubber blocks on top to provide additional support and damping for the lid.

One soon perceives that the amplifier could easily have been encased in a package with a quarter of the space. That approach would most probably have resulted in reduced sales as 'things in little boxes never sell as well as the same item packaged in a bigger box'. All of the wiring is neatly executed in ribbon cables with plugs and sockets to assist in assembly and servicing and, although the contents are relatively sparse that is by no means objectionable.

Objective testing

The objective assessment of the amplifier performance soon confirmed that the circuit designers at Yamaha really know what they are doing. The frequency response of the amplifier is virtually ruler flat from 25 Hz to beyond 100 kHz and is only 3 dB down at 9 Hz and 200 kHz. The input sensitivities are identical for the CD input, auxiliary input, tuner input and tape input while the phono input has a very sensible 0.48 millivolts input sensitivity (for 1 watt output) and 109 millivolts overload level. That latter figure would obviously require many times the power capabilities of the power amplifier to produce an overload condition.

The input impedances for each of the inputs (including phono) is 45k ohms, a reasonably sensible value, while the output impedance is only 168 milliohms.

The measured hum and noise levels (relative to 1 watt) are particularly good with -86 dB(A) for all the auxiliary and associated inputs and an excellent -83 dB(A) for the phono input. These low figures have been aimed at ensuring the amplifier is good enough for the best record player and cartridge and equally well matched for the finest CD player available.

The total harmonic distortion figures we measured at the 1 watt level were 0.0078% at 100 Hz, 0.0019% at 1 kHz and 0.01% at 6.3 kHz. These figures did not deteriorate significantly at the 50 watt level into 8 ohms where the distortion at 100 Hz was 0.01%, at 1 kHz was 0.008% and at 6.3 kHz was 0.0058%. When performing the objective measurements the manufacturer's tentative performance data (in particular the power ratings) had not been received. We consequently carried out the distortion measurements at a 50 watt power level rather than at the 30 watt level where the overall distortion would have been substantially lower. It is worthwhile highlighting that these distortion figures are markedly better than those of the QED A230, are comparable with those of the ME 15 amplifier and slightly better than those of the Perreux

model PMF 115B power amplifier (which of course can deliver much more power).

The measurements of the IEC high frequency total difference frequency distortion confirmed the lowest distortion levels in the 10 to 30 watt region and generally acceptable total distortion levels all the way up to an output power of 50 watts per channel (with both channels driven).

Although the manufacturer's tentative literature also claims 'high dynamic power' we were only able to measure 56 watts into 8 ohms, 75 watts into 4 ohms and 80 watts peak into 2 ohms. I also noted that the manufacturer does not actually warrant the amplifier at the 4 ohm or 2 ohm output level, and the back panel specifically cautions connection to speakers with impedances in the 8-16 ohm range.

The transient overload tests performed in accordance with the IHF-A-202 procedure revealed excellent stability and absolutely no trace of jitter or carry over of overload instability following the application of an overload signal to any of the inputs.

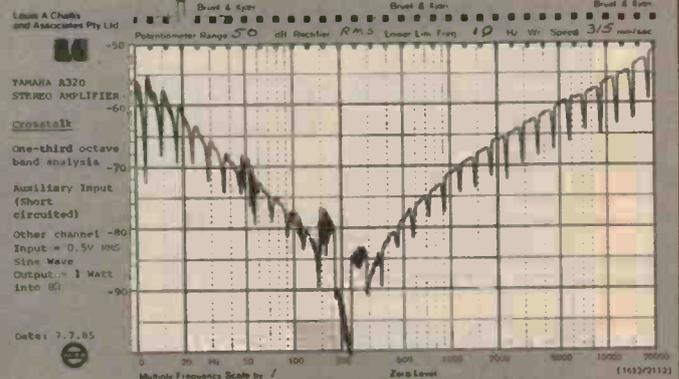
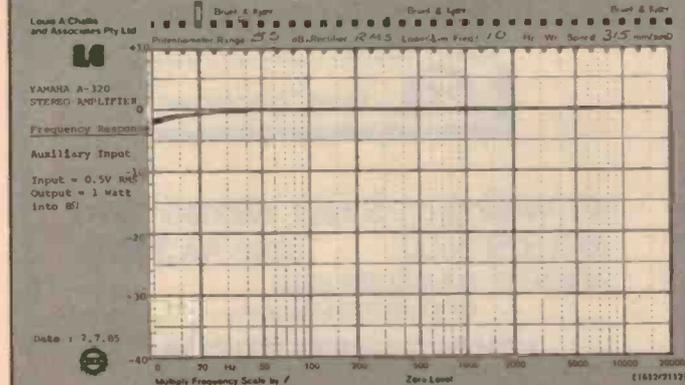
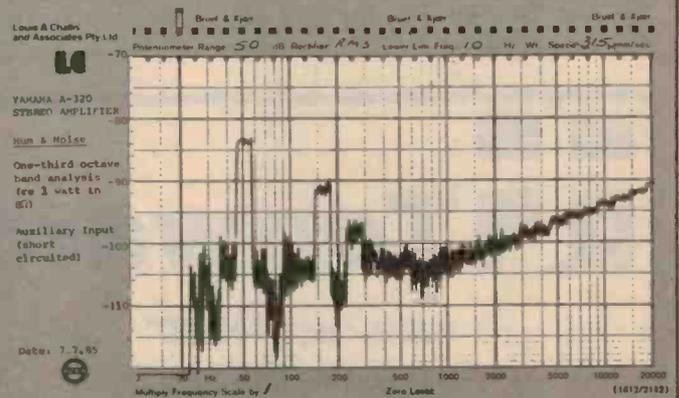
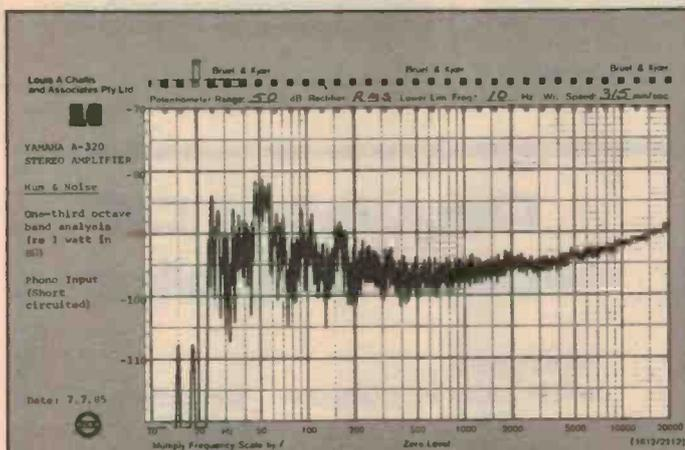
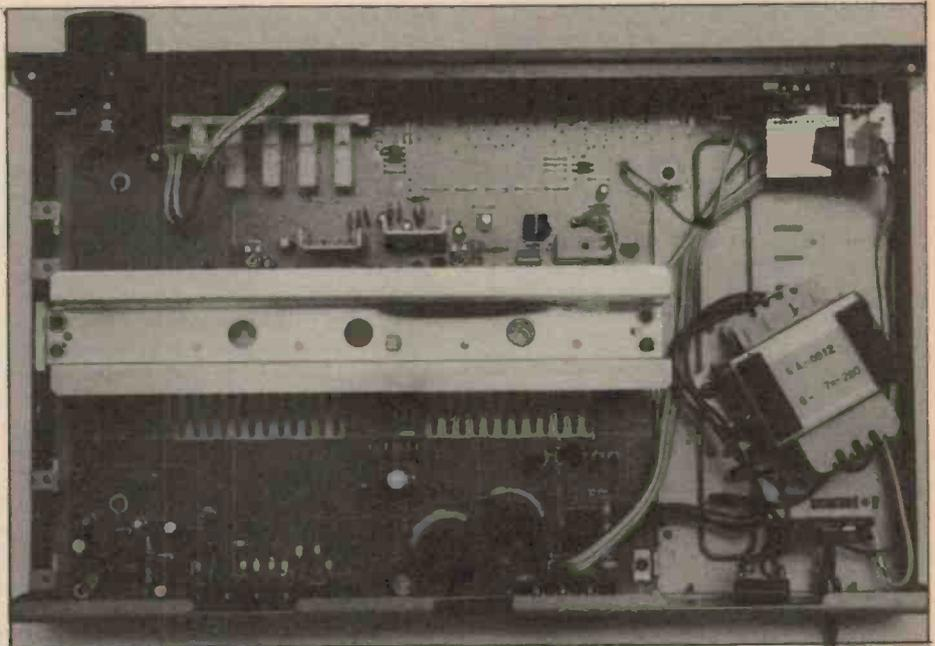

SOUND REVIEW

Subjective testing

The subjective assessment of the amplifier revealed that the A-320 is a truly outstanding little amplifier, output power of which is suitable for listening to classical music or medium power jazz and is happy with medium to low efficiency speakers, provided you don't wish to drive the amplifier too hard on transients.

Connected to a pair of B&W 801F monitors and comparing the output from a Yamaha C2A pre-amplifier and 101/M power amplifier, the only detectable difference was the ability of the 'affluent relatives' to produce power outputs 10 dB (10 times) higher. If anything, the hum and noise characteristics of the A-320 are very slightly smoother than those produced by the A101 amplifier and this is to a large measure due to superior and simpler electronics.

I listened to a range of new compact discs from Denon including 'The Complete Sonatas for Piano' Volume 5 played by Maria Joao Pires (Denon C37-7390) which is an exquisite rendition of some of Mozart's most beautiful works and exemplifies the quality of the latest CD discs being produced in Japan.

The next disc I listened to was the latest

Telarc digital sampler entitled 'Time Warp' (Telarc CD-80106) with Erich Kunzel leading the Cincinnati Pops Orchestra. Track one with 'Also Sprach Zarathustra' and track nine 'Gayne Ballet' by Aram Khachaturian provide exceedingly high transient signals which the A-320 handled with the aplomb of a more powerful amplifier delivering healthy 100 dB transient and crescendo levels with a pair of B&W 801Fs.

Another new disc I listened to was 'Perfect Stranger' by Deep Purple (Polydor Stereo 823-777-2) where each of the tracks provides excellent heavy rock music with which the amplifier was quite at home at listening levels of up to 100 dB.

Last of all I listened to the latest Denon digital audio check CD which only reinforced my opinion regarding the quality and lack of electronic colouration or distortion provided by the A-320 amplifier.

All of the new software (as well as the well tried and tested discs and records, which I used) convinced me how good this amplifier really is. At a recommended retail price of \$299, this amplifier obviously constitutes good value. However, at the discount prices which I expect many retailers will offer, this amplifier should prove to be truly exceptional value for the money. ●

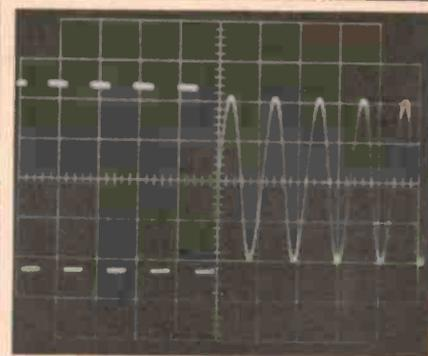

1 ms/div

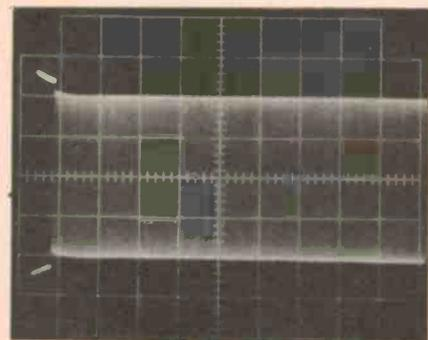

50 ms/div

Measured performance in transient overload recovery test (IHF-A-202). 10 dB overload re-rated power into 8 ohms both channels driven. Overload duration: 20 ms; repetition rate: 512 ms.

Topward

MODEL 4303 **\$445.00***

MODEL 4302 **\$429.00***

MODEL 2303 **\$255.00***

MODEL 2302 **\$229.00***

*Plus Sales Tax.

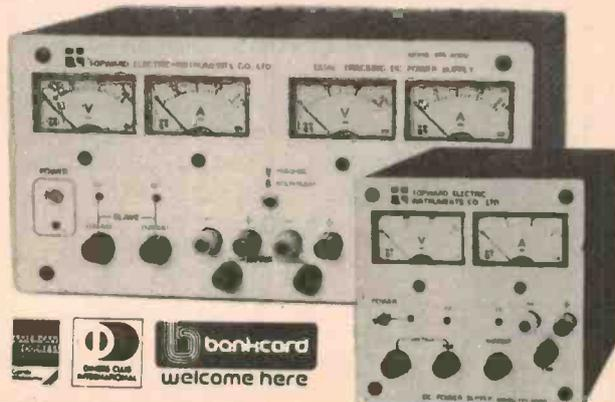

Regulated DC Power Supplies

FEATURES:

- 4303 (4302) Triple Output — ± 30 volt/3A (2A) +5 volt 3/A
- 2303 (2302) Single Output — ± 30 volt/3A (2A)
- Constant voltage and current capability
- Short circuit protection
- Extremely low ripple and internal resistance
- Compact size

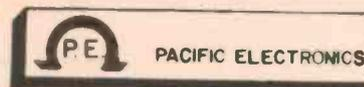

45 Wellington Street Windsor 3181
(03) 529 8500 Telex: AA 38432

AGENTS: SA (08) 264 5237
QLD (070) 51 2404

DEALER ENQUIRIES WELCOME

POLYESTER 100V "GREENCAP" TYPE

Cat No.	1-99	100+	1000+	
R15131	.001uF	0.06	0.04	.036
R15137	.0012uF	0.06	0.04	.036
R15138	.0015uF	0.06	0.04	.036
R15140	.0022uF	0.06	0.04	.036
R15142	.0033uF	0.06	0.04	.036
R15143	.0039uF	0.06	0.04	.036
R15145	.0047uF	0.06	0.04	.036
R15146	.0056uF	0.06	0.04	.036
R15147	.0082uF	0.06	0.04	.036
R15148	.01uF	0.07	0.05	.045
R15150	.015uF	0.07	0.05	.045
R15152	.022uF	0.07	0.05	.045
R15154	.033uF	0.07	0.05	.045
R15155	.039uF	0.07	0.05	.045
R15156	.047uF	0.08	0.06	.055
R15157	.056uF	0.08	0.06	.055
R15158	.088uF	0.08	0.06	.055
R15159	.082uF	0.08	0.07	.065
R15160	.1uF	0.09	0.08	.07
R15162	.15uF	0.11	0.10	.09
R15164	.22uF	0.15	0.14	.13
R15165	.27uF	0.16	0.15	.14
R15172	.1uF	0.70	0.55	0.50
R15176	2.2u	1.20	1.10	1.00
R15178	3.3uF	1.50	1.20	

Plus 32 1/2% tax where applicable

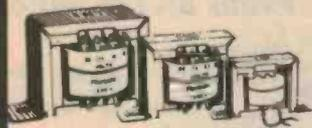

TRANSFORMERS

Cat No.	1-99	100+	1000+	
M12851	2851	2.50	2.25	1.000+
240V 12-6V CT 150mA				
M12155	2155	4.80	4.10	3.70
240V 8-15V 1A tapped				
M12156	2156	6.35	6.15	5.95
240V 8-15V 2A tapped				
M16672	6672	6.35	6.15	5.95
240V 15-30V 1A tapped				

Plus 20% tax where applicable



HORN SPEAKERS

Cat No.	1-99	100+	
C12010	5" Plastic 8W Max	4.80	4.70
C12015	5" Metal 8W Max	4.70	4.30
C12012	12V Siren	8.50	8.00

Plus 20% tax where applicable



NEW SWITCHES

SPDT Cat.	10-99	100+	
S11040	1.00	.95	
DPDT Cat.	S11042	1.20	1.00

Plus 20% Sales Tax where applicable



PANEL METERS

	1-9	10+	100+	
Q10500	MU45 0-1mA	6.95	6.75	6.50
Q10502	MU45 50-0-50uA	6.95	6.75	6.50
Q10504	MU45 0-100uA	6.95	6.75	6.50
Q10505	MU45 0-50uA	6.95	6.75	6.50
Q10510	MU45 0-5A	6.95	6.75	6.50
Q10518	MU45 0-1A	6.95	6.75	6.50
Q10520	MU45 0-20V	6.95	6.75	6.50
Q10535	MU45 VU	7.95	7.75	7.50
Q10530	MU52E 0-1mA	9.95	8.35	
Q10533	MU52E 0-5mA	9.95	8.35	
Q10538	MU65 0-50uA	9.35	8.95	8.75
Q10540	MU65 0-1mA	9.35	8.95	8.75
Q10550	MU65 0-100uA	9.35	8.95	8.75
Q10560	MU65 0-20v	9.35	8.95	8.75

Plus 20% tax where applicable

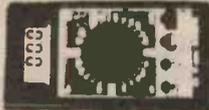

YU-FONG YFE-1030C

Features:
 • Large 3 1/2 digit display. (1/2 inch high)
 • Auto polarity. "-" display for Negative input.
 • High over-load protection for all ranges.
 • Over-load display highest figure "1" or "-1" alone glows.
 • Power consumption 20mW approx.
 Cat. Q126030
 1-99 100+
 43.95 34.00

TRANSISTOR

	10-99	100+	1000+		
2SJ49	4.90	4.50	4.90	4.50	
PN2222A	.10	.08	PN2907A	.10	.08
PN3463	.15	.13	PN3565	.12	.11
PN3566	.15	.13	PN3567	.10	.08
PN3569	.18	.16	PN3639	.18	.16
PN3640	.18	.16	PN3641	.10	.08
PN3642	.10	.08	PN3643	.10	.08
PN3644	.15	.13	PN3645	.15	.13
PN4250A	.15	.13	PN4355	.16	.14
PN4356	.16	.14	MPSA42	.23	.20
MPSA43	.23	.20	MPSA55	.15	.14
MPSA56	.15	.14	MPSA92	.22	.20
MPSA93	.22	.20	SC1410	.85	.75
BU126	1.50	1.25	BUX80	2.50	2.20
BU206	2.50	2.20	2SD350	2.50	2.20

Plus 32 1/2% tax where applicable



FANS

Cat.	1-9	10+	100+	
T12461	240V 4 1/2"	10.50	10.00	8.00
T12465	240V 3 1/2"	10.50	10.00	8.00
T12463	115V 4 1/2"	10.50	10.00	8.00
T12467	115V 3 1/2"	10.50	10.00	8.00

Plus 20% tax where applicable

DIP SWITCHES

	10+	100+	1000+
S13402	2 Way .70	.65	.50
S13404	4 Way .80	.75	.70
S13405	5 Way .90	.85	.90
S13407	7 Way 1.10	1.00	.95
S13408	8 Way 1.20	1.10	1.00

20% Sales tax where applicable



MINITURE BUZZER

5-15V White or black
 Cat. A15062 10-99 100+
 0.90 0.80
 Plus 20% tax where applicable

SEALED LEAD ACID BATTERY 12V 1.2 AH

S15029	1-9	10-99	100+
	12.50	11.00	10.50



COMPUTER CONNECTORS

Cat No.	Description	1-99	100+	1000+
P10900	DB25 Plug	1.30	1.20	1.00
P10901	DB25 Socket	1.40	1.30	1.20
P12210	Centronics Solder	3.50	3.15	2.50
P12200	Centronics Crimp	6.00	5.50	5.00
P10880	DB9 Plug	1.30	1.20	0.90
P10881	DB9 Socket	1.40	1.30	1.00
P10890	DB15 Plug	1.30	1.20	0.90
P10891	DB15 Socket	1.40	1.30	1.00
P10902	DB25 Cover	.80	.75	.70

Plus 20% tax where applicable



CANNON TYPE AUDIO CONNECTORS

We've sold 1000's because of their great value!!
 1-9 10+
 3 Pin Line male Cat. P10960 1.80 1.80
 3 Pin Chas male Cat. P10962 1.90 1.70
 3 Pin line female Cat. P10964 2.50 2.20
 3 Pin Chas FMie Cat. P10966 2.90 2.50
 Plus 20% Sales Tax where applicable

RELAYS

Massive 3A connectors
 1-9 10+ 100+
 S.P.D.T. Cat. S14060 \$1.20 \$1.10 \$0.90
 D.P.D.T. Cat. S14061 \$1.50 \$1.40 \$1.20



75OHM COAXIAL CABLE

Cat No.	100M	500M	1000M
W11222 3C2V	18.00	17.00	16.00
W11224 5C2V	27.00	25.00	24.00

(5C2V WHITE OR BLACK)
 100M ROLLS

LINE LOSS PER 100' (33M 200MHz)

W11222 6.2dB (Approx)

W11224 3.9dB (Approx)

Plus 20% tax where applicable



GREY FLAT RIBBON CABLE

Cat No.	Desc.	PER 100 FT ROLL			
		Per Mtr 1-3	4-9	10-99	100+
W12614	14 Way	1.29	19.50	18.50	14.00
W12616	16 Way	1.90	21.50	19.50	16.00
W12620	20 Way	2.20	29.50	26.00	20.00
W12625	25 Way	2.50	32.50	29.00	25.00
W12626	26 Way	2.50	34.00	32.00	26.00
W12634	34 Way	2.80	44.00	42.00	34.00
W12636	36 Way	3.00	49.00	47.00	36.00
W12640	40 Way	3.20	55.00	52.50	40.00
W12650	50 Way	3.75	62.00	59.50	50.00

EX STOCK

LARGER QUANTITIES NEGOTIABLE

Plus 20% tax where applicable

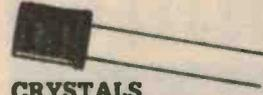

CRYSTALS

Cat No.	Frequency	Can 10+	100+	500+	1000+	
Y11000	1MHz	HC33	5.50	4.75	4.50	4.00
Y11005	2MHz	HC33	2.25	1.95	1.85	1.70
Y11008	2.4576MHz	HC33	2.25	1.95	1.85	1.70
Y11015	3.57954MHz	HC18	1.20	.90	.85	.60
Y11020	4.00MHz	HC18	1.30	.90	.75	.60
Y11022	4.194304MHz	HC18	1.40	.90	.75	.60
Y11025	4.75MHz	HC18	1.40	.90	.75	.60
Y11026	4.9152MHz	HC18	1.40	.90	.75	.60
Y11042	6.144MHz	HC18	1.40	.90	.75	.60
Y11050	8.00MHz	HC18	1.40	.90	.75	.60
Y11055	8.867238MHz	HC18	1.40	.90	.75	.60
Y11070	12.00MHz	HC18	1.40	.90	.75	.60
Y11072	14.318MHz	HC18	1.40	.90	.75	.60
Y11080	16.00MHz	HC18	1.40	.90	.75	.60
Y11085	18.432MHz	HC18	1.40	.90	.75	.60
Y11090	20.00MHz	HC18	1.40	.90	.75	.60

FULL RANGE OF CRYSTALS AVAILABLE ON INDENT

Plus 20% tax where applicable

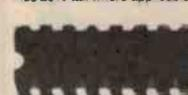

MEMORY

"Check for the latest memory prices!"

	10-99	100+	1000+	10K+
4164-15P	\$2.00	\$1.50	\$1.30	\$1.10
41256	\$7.00	\$6.00	\$5.50	\$5.00
6116P-3	\$3.00	\$2.90	\$1.80	\$1.50
2716	\$4.90	\$4.50	\$4.25	\$4.00
27128	\$7.00	\$6.00	\$5.00	\$4.00
2532	\$7.50	\$6.50	\$6.40	\$6.30
2732	\$6.50	\$6.10	\$5.90	\$5.50
27256	\$29.00	\$27.00	\$22.00	19.00
6264	\$9.00	\$7.50	\$6.00	\$5.50

Plus 20% tax where applicable



VERBATIM DATA LIFE DISKETTES

	10-99	100+	1000+	
SS/DD	MD525-01	2.50	2.35	2.25
DS/DD	MD550-01	3.20	3.00	2.80

XIDEX DISKETTES

	10-99	100+	1000+	
SS/DD		2.50	2.50	2.25
DS/DD		3.40	3.05	2.85

Plus 20% tax where applicable



RITRON II

Swivel base monitor in stylish case.

	1-9	10+	
Green Cat.	X14506	\$165	\$159
Amber Cat.	X14508	\$165	\$159

Plus 20% tax where applicable

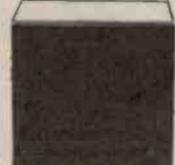

MONITORS

Cat No.	1-3	4+	
X14500	Ritron 1 Green	\$140.00	\$135.00
X14502	Ritron 1 Amber	\$145.00	\$140.00

WHILE STOCKS LAST

Plus 20% tax where applicable

UNPROTECTED HEADERS STRIP HEADERS

	1-9	10+	
P12240	10 Way Unprot Header	1.25	1.10
P12245	16 Way Unprot Header	1.35	1.20
P12250	20 Way Unprot Header		

BANKCARD HOLDERS—PHONE ALTRONICS TOLL FREE 008 • 999 • 007 FOR NEXT DAY JETSERVICE DELIVERY

ALTRONICS 9th Birthday Sale

COMPONENTS

• Hundreds of Quality Electronic

Save up to 50% on

Credit Cards accepted — You don't pay a



AM Stereo Sensation!

★ AM Stereo ★ FM Stereo ★ Auto reverse Tape Deck

Why Pay \$300—\$400??

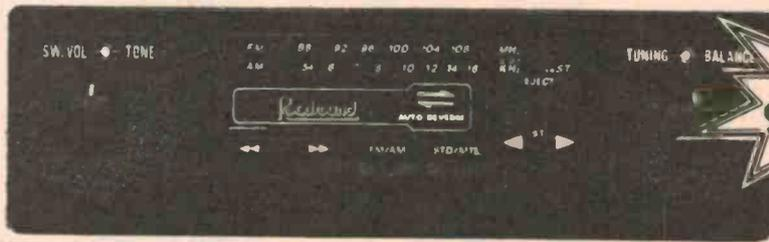

\$199

AM Stereo is here to stay (at long last!) Of course up until now it has cost a kings ransom for AM Stereo Car Sound. We hear of price tags of \$400 and up. Well — No More!! We At Altronics are proud to announce the release in Australia of the superbly engineered Roadsound RCR.760 AM Stereo/FM Stereo auto reverse cassette player. Manufactured in Japan, this fine set utilises the brilliant Motorola C-Quam system and is designed for Australian transmission specifications. Naturally the FM receiver is excellent and the robust auto reverse tape deck features metal tape compatibility and exhibits wow and flutter typically less than .25%. Audio output is 8 watts channel. Frequency response extends beyond 12KHz.

Treat yourself today to the greatest thing to happen to AM Radio in 60 years! Cat C 9122.

GRAPHIC EQUALISER 7 BAND

30 watt per channel

\$55.00

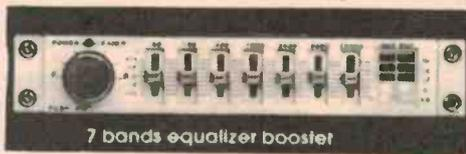

Ultra compact car sound graphic. Simply feed your car radio or Radio Cassette player through this great amplifier and be amazed at the difference. 30 watts max. per channel — frequency Response to 20KHz. Mounts conveniently under the dash. Cat 9132

Roadsound 6.5 inch coaxial Flush Car Speakers

30 watt Max. C 9380 \$39.95

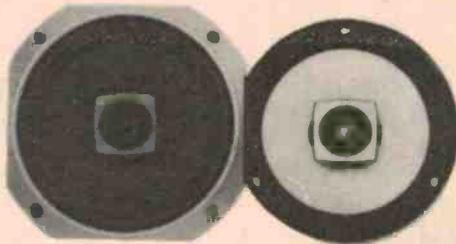

Superb Itron 35W Rear Shelf Wedge 3 way Speakers

Separate Bass, Midrange and Dome Tweeters - Crystal clear Hi Fi performance. Cat C 9384



\$59 pair

MOTORIZED ANTENNA FULLY AUTOMATIC

Extends automatically when ignition is turned on. Retracts similarly when turned off. Full kit includes all accessories and fixings. Full instructions included. Cat C 9420

\$45.00

\$39.00



Look at This!
Superb Quality Nicad Rechargeable's
From an Incredible

\$1.50



Save Up to 50%

1-9 \$2.20
10-99 \$1.80
100 Plus \$1.50 ea.

Cat S 5020

SAVE \$5



MULTIPURPOSE NICAD BATTERY CHARGER

With the increasing popularity of Nicad rechargeable batteries, this low cost multipurpose charger is just what the doctor ordered. Charges every conceivable battery from AAA through to 9V.

M 8010 NOW \$19.95

BICYCLE COMPUTER INCREDIBLE 12 FUNCTION Cat D 2050

The brilliant BIKOMP COMPUTER that is all the rage in USA is now available in Australia. For a few dollars more than a digital speedo this superbly accurate computer provides every actively readout the enthusiast cyclist is ever likely to require.

NOW \$49

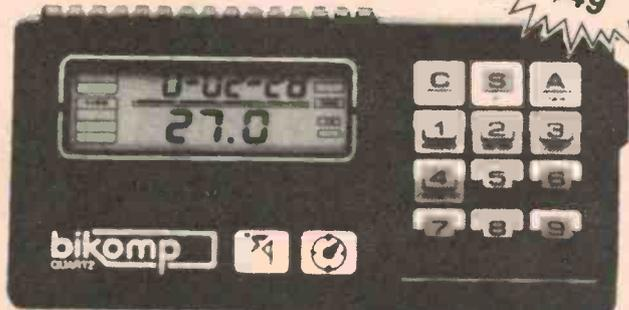

- Instantaneous Average & Peak Speed Readouts.
- Measures Calories Used per Trip.
- Measures Distance.
- Clock, Stopwatch and journey time (whilst Mobile)

- Miles or Kilometres
- Pacer Tone and Performance Monitor
- Dual Display
- Easy Removal for Security
- Fits to Bike in minutes

Bonanza

Components and Products —
our Competitors prices.

cent until you get your statement next month!

With Altronics Jetservice
We deliver to Your Door Next Day
— Just Try Us !! —
(Capital Cities & Suburbs - Country areas allow extra 24 - 48 hours)



BANKCARD HOLDERS—PHONE ALTRONICS TOLL FREE 008 • 999 • 007 FOR NEXT DAY JETSERVICE DELIVERY

Desk Mounted Lamp Magnifier



Only \$169

This unit magnifies any object under a clear cool florescent light. The magnification is the maximum obtainable (lens 127mm diameter biconvex 4 Dioptres, focal length 254mm) consistent with minimum distortion and eyestrain and good off-angle viewing. It is NOT cheap, but then again it will definitely last a lifetime. It is built like a Rolls Royce. (We doubt whether 20 years continuous use would wear out the German made flexible arms for example). Spare fluoro tubes are available either from us or electrical outlets.

If you have trouble with fine PCB work or component identification but still want both hands free, this is for you. We thoroughly recommend this quality Australian made product.

TECHNICAL INFORMATION - Illumination: 22W Fluorescent Weight: 8.16kg Lateral Extension: 254mm Vertical Extension: 254mm Fixing: Heavy table base (grey & Ivory) with two chrome plated flexible arms. Lens: (see text) Cat A 0980

VHS VIDEO TAPE EXCELLENCE



We've tested the lot - Well how does ME stack up? — in a word superb - Forget all about paying a premium for BASF or TDK—Altronics positively guarantee our new ME Metallics equal to the very best—and that goes for mechanical construction as well as picture quality!

Were \$12.00 Limited Stocks Cat A 9330

NOW \$9.90

10Up \$8.90

BLOOD PRESSURE & HEART RATE MONITOR

Why Risk Unnecessary Heart Attack?

A simple (take the reading yourself) periodic check of your blood pressure and pulse provides an "inward look" into a vital aspect of your bodily health. Heart disease strikes down many people in their early 40's (or even 30's). The tragedy remains that had such victims been alerted, remedial medical, physical and dietary action could have been prescribed to avoid illness and in many cases restore full bodily health.

A superb Gift for the dedicated fitness enthusiast Absolutely essential for those over 40 and concerned with their health, or on Fitness Therapy. Use this easy to operate Monitor, to measure your pulse (or heart rate) and Blood Pressure. Remember high blood pressure is in itself symptomless and the usual forerunner to future chronic heart disease. Features include "error" display warning of incorrect use. Handbook supplied will enable anyone in your family to be fully conversant with this monitor in minutes. Easy to read display of Systolic and Diastolic Blood Pressure and Pulse Rate. Cat X 3055

Don't Pay \$150 Now Only \$89



Brilliant Smoke/Fire Detector

100 Only — Great for Boat, Caravan, Home.

Every year 100's of Australian Men Women and Children perish through house fires and smoke Inhalation.

Virtually none would have died had a Smoke Sentry Alarm been fitted to their home. Cat A 0090

Be Quick 100 Only Were Selling for \$59.95 **\$14.99**



Does not include battery.

- Brilliantly Designed Dual Chamber Ionisation sensor detects particles of combustion (smoke) at earliest stages of fire e.g. smouldering etc.
- Loud, persistent 85db alarm wakes the soundest of sleepers.
- Low cost 9 volt battery lasts approx. 1 year, easily replaced.
- Low battery alarm • Test Switch.
- Dead easy to install-takes less than 10 minutes-all you need is a screw driver. Protect yourself and your whole family as of today.

Magneto Torch \$3

This handy little flashlight uses no batteries and is every bit as bright as your average torch. The squeeze/spring action hand grip drives a tiny inbuilt Magneto. Just the job for the car glove box, boat, holiday flat, or for anywhere where you need an occasional flashlight without ever having to buy a single battery. Where selling for over \$20!! Altronics Sale Price Just \$3. Cat A 0950 Dimensions 120 x 60 x 60.



Bonus Free Offer

Normally \$7.95

When ordering from this advertising - please tell us where you saw the advert - e.g. E.A. ETI etc. This will be of enormous benefit to our future advert planning and as a gesture of our appreciation we will send you our super handy 13 piece Drill Set absolutely Free Grats.

Cat T 2330 High Speed Sizes 1.5 to 6.5mm

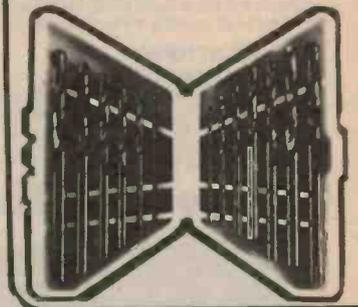

Entertainers Microphone

Dynamic Low Impedance 600 Ohm Fitted with Lead and Jack Plug

A scoop purchase of these surprising quality entertainers Microphone allows us to pass these on to you at an unbelievable price - these recently sold for nearly \$40!! - Sturdy construction, frequency response 80-15KHz



Desk Top Calculator

Just released for 1985. New technology now allows powering of large desk top type display as used with our new X 1050. No more batteries to go flat. No more Batteries to leak! No more Batteries!!! Perfect for Home or Office Fantastic Value. Cat X 1060

Was \$19.95

Now

\$15

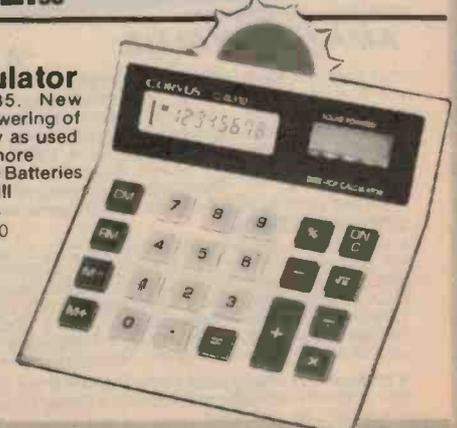

BANKCARD HOLDERS—PHONE ALTRONICS TOLL FREE 008 • 999 • 007 FOR NEXT DAY JETSERVICE DELIVERY

ALTRONICS COMPONENTS

9th Birthday Sale

• Hundreds of Quality Electronic

Save up to 50% on

Credit Cards accepted — You don't pay a



Stereo Mixers at Low Import Price

ATTENTION—Social Clubs, Schools, Churches, Disco Operators, Entertainers, Hotels, Night Clubs and sporting Bodies. With Altronics low prices—here is your opportunity to install one of these outstanding sound control mixers. Both models include microphone "Soundover" facility—making either ideal for live entertainment use.

Stereo Audio Mixer

A 2550

\$125

240V Mains Operated



This brilliant little mixing console is absolutely packed with features. Allows blending of Microphone, two Phono inputs and either two Tape or Turner inputs • Right and left VU meters • Separate Bass and Treble controls • 5 slide level controls • Fader control between Phono pickups for professional cueing • Headphone monitor switch • Talkover facility.

SPECIFICATIONS:

• Input Mic 0.5mV 600 Ohms Phono 3mV 50K Ohms Tape/Tuner 150mV 100K Ohms • Output 250mV • Frequency Response 20Hz to 20KHz (plus or minus 1db) • Tone Control (Treble) 10KHz (plus or minus 12db) • Tone Control (Bass) 100Hz (plus or minus 12db) • Distortion Less than 0.07% • S/N Ratio More than 60db • Headphone Impedance 4—6 Ohms • Dimensions 318 (L) x 217 (W) x 85 (H)

Pro-Quality Stereo Console



240V Mains Operated

AMAZING VALUE

A 2570 **\$399**

Our sophisticated 'NEW' Audio Mixing Console is ideal for 'live' recording • PA mixing • Fantastic Tape recordings • Even Stereo/Mono VCR recording. A truly professional deck that features separate R/L 5 band graphic equalisers • Echo and Peak LED level indicators • Talkover facility • Separate H/Phone level control • Patch switch bank • Individual microphone, Phono 1, Phono 2, Aux/Line 1, Aux/Line 2, and Master slide level controls. — Blend up to two magnetic or crystal turntables, two tape decks or tuners and two microphones all at once!

SPECIFICATIONS:

• Input Mic 1—0.5mV 600 Ohms Mic 2—0.5mV 600 Ohms Mic 2—0.5mV 600 Ohms (low imp.) 2.5mV 10K Ohms (low imp.) Phono 1 & 2 (Mag) 3mV 50K Ohms Phono 1 & 2 (Cry) 150mV 100K Ohms Tape/Tuner 1 & 2 150mV 100K Ohms • Equaliser 5 frequency bands—60Hz, 250Hz, 1KHz, 4KHz, 12KHz—Boost Cut range-plus or minus 12db @ Centre frequency. • Output 1.5V/0.775V (Selectable) • Frequency Response 20Hz to 20KHz plus or minus 1db • Distortion Less than 0.05% • S/N Ratio More than 50db • Headphone Impedance 4—16 Ohms • Echo B.B.D. System • Delay Time 30—200mS • Echo Repeat Control • Delay Time Control • Dimensions 480 (L) x 240 (W) x 110 (H)



NEW \$89

UV EPROM ERASER

Cat D 1450

Erase your EPROMS quickly and safely. This unit is the cost-effective solution to your problems. It will erase up to 9 x 24 pin devices in complete safety in about 40 minutes for 9 chips (less for less chips).
• Erase up to 9 chips at a time • Chip drawer has conductive foam pad • Mains Powered • High UV intensity at chip surface ensures thorough erase • Engineered to prevent UV exposure • Long Life UV tube • Dimensions 217 x 80 x 68mm • Weight 670 grams

AC ADAPTORS

SEC APPROVED

M 9000

240/3,4,5,6,7,5,9,12V at 300mA
Multiway Connector fitted

\$14.50 5Up 12.95

MULTIWAY CONNECTOR FITTED

M 9005

240/6,9,12V at 500mA

\$16.95 5Up \$15.50

FAMOUS CALL MASTER PHONE ANSWERING MACHINES

With Callmaster you'll never miss a call again just because you weren't near the telephone when it rang. Callmaster answers for you, in your own voice if you wish, then records and stores the callers messages for your convenience.

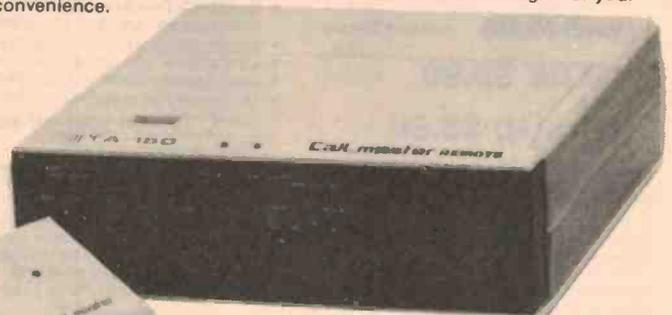

Standard Model A 0510 **\$229**

Remote control model A 0515 **\$299**

DUAL CASSETTS • MONITORING FUNCTION • CONDENSOR MICROPHONE • LARGE INCOMING MESSAGE CAPACITY • EASY CHANGE OF OUTGOING MESSAGES • CALLING PARTY CONTROL • REMOTE CONTROL (A 0515 only) • FAST FORWARD (A 0515 only) • PRECISION AND QUALITY - Callmaster is designed especially for Australian telephone conditions and precision manufactured in Japan, assuring unequalled performance and reliability.
TELECOM - Callmaster A 0510 and A 0515 are both permitted for direct connection to the telephone network. You just plug it in!
Telecom Australia Permit # C81—16—18
Energy Authority of N.S.W. Certificate # CS2029N

ALL THESE FEATURES PLUS A FULL 12 MONTHS WARRANTY AGAINST FAULTY WORKMANSHIP OR MATERIALS

Bonanza

Components and Products —
our Competitors prices.

cent until you get your statement next month!

Remember Altronics
Famous 14 Day Money Back
Satisfaction Guarantee



THE AVTEK MULTIMODEM

A breakthrough in low cost modem design. Digital signal processing is used to achieve functions normally requiring analogue filters.

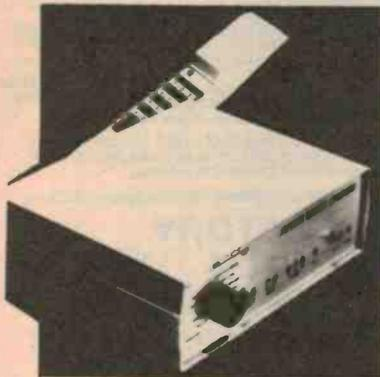

MULTIMODEM NEVER REQUIRES ADJUSTMENT

MULTIMODEM WORKS RELIABLY ON LINES WHERE OTHER MODEMS CAN'T FUNCTION
Its digital filters are much sharper than on conventional modems. Line interference is screened out. You get error free data transfer, even on very noisy lines.

MULTISTANDARD OPERATION
CCITT and Bell Duplex and Half Duplex.

AUTO ANSWER OPTION (MODEL D 1205)

Autoanswer is the ability of your computer/modem to receive when the phone rings. Leave your computer waiting for information.

TEST FUNCTIONS

DIG: This function enables the user to test the modem's operation over a line, testing both modem and line.
ANL: Provides testing of computer, software, cabling and modem.

SPECIFICATIONS

Data Standards: CCITT V.21 & V.23 Bell 103 and 22
Data Rates: 300,600 & 1200 BPS
Backward Channel: BPS in conjunction with 1200 BPS
Computer Interface: CCITT V.24 (RS232C)
Power Requirement: 240 VAC Power drain — 3 watts

TWO MODELS

D 1200 (Standard) **\$349**
D 1205 with auto answer **\$389**

MICRO RADAR DETECTOR CLIPS ONTO SUNVISOR

Now X band, K band stationary, gun or even Mobile Radar are detected up to an amazing 13Km with the all new "Space Age" Micro Compuheterodyne Radar Detector. The very first in the world to utilize a custom microprocessor—hence enabling quite incredible sampling/checking detection of incoming signals—and what's more it's so light and compact it simply clips securely on to your sunvisor out of sight of anyone outside the vehicle.

• Detects Mobile Radar equipment even monitors the pulse which is sent to the road from the Police vehicle to enable them to accurately calibrate their own speed • Highway/City Mode switch allows monitoring of City or Highway conditions. By measuring and storing the field strength of each microwave sample taken from the source, the compuheterodyne will automatically, whilst in City Mode, discriminate between Microwave Alarm Systems and Radar Traps etc. — 21 Day Money Back Guarantee Unconditionally Guaranteed to out perform any other detector you've ever tried or your money back—absolutely no quibbles whatsoever.



Cat
A 0920
\$399

27 Meg Band Transceiver plus Seaphone FM Receiver Bands 16 (emergency) and 67 (weather)

Its Now Official !!

The Brilliant Sea Wasp is now miles in front of any other Marine Two-Way in Australia Under \$200



Just Released
Uniden Sea Wasp Marine 2 way Radio
10 Channels 27 Meg. Marine Band Transmit and Receive.
Plus Seaphone FM Channels 16 (emergency) and 67 (continuous weather and sea conditions reports) Receive facility.

C 5012 Only **\$199**

Designed for Australia our fantastic new Uniden Sea Wasp Transceiver includes allocated 27Meg. Marine channels for normal boat to boat and boat to shore communication and emergency calls. The Big Bonus is the inclusion of the Seaphone FM channels 16 (emergency 156.8MHz) and 67 (weather/sea reports 156.375MHz) receive channels. Now you can listen out for other craft in distress or get up to the minute sea and weather reports whilst fishing or relaxing in that bay 30KM from home. Another Fantastic Feature of this Radio is the simple "One Touch" emergency switch, i.e. a person totally unfamiliar with 2 way radio operation can, in an emergency, i.e. boat fire, capsiz etc simply select the "88" (or 27.88MHz) override button and make that life saving call.

FACILITIES

• In-built Signal Meter indicates level of both incoming and outgoing transmissions • CB/PA Switch with external horn speaker (C 2010) fitted, you now have a handy little Boat PA System • WX1 (CH16) and WX2 (C-67) Selector switch independent of Main Channel Selector • Noise Limiter • RF Gain Control • Mic Gain Control • Digital Channel readout.

SPECIFICATION:

Channels RX/TX	10.27.680-27.980Mhz	Accessories	DC power cable with fuse, microphone and mic.clip.
Channels RX (WX)	2.CH16 156.8Mhz.CH67 156.375Mhz	Transmitter RF Power	4 Watt
Speaker	In-built plus external speaker Jack	Receiver Sensitivity	5uV/12db SNR.
Size/Weight	160W x 55H x 217D.1.2KG	Squelch Range	1—1000uV
		Audio O/P	5W
		PA Facility	Included 5W O/P

Helical Whip Antenna with Ground Plane Eliminator.

1.4m length suitable for horizontal mounting surfaces—angle bushing supplied allows mounting to sloping surfaces. Complete with lead and PL259 plug. Pretuned for 27Mhz Marine band.

C 5100 **\$39.50**

Deluxe 9' Whip with Multiway Base Mount

Superb pretuned 27Mhz Marine Antenna with sturdy multiway mount. With mount on horizontal, vertical or angled surfaces—Very efficient.

C 5110 **\$69.50**

Free Bonus Offer

Free booklet on the Coast Radio Service throughout Australia with each Sea Wasp Sale.



1/2 PRICE TELEPHONE EXTENSION LEADS AND ADAPTOR

P 0990	5 Metre ext.lead	\$14.95	Now	\$7.50
P 0992	10 Metre ext.lead	\$17.50	Now	\$8.50
P 0995	Double Adaptor	\$12.50	Now	\$6.50



BANKCARD HOLDERS—PHONE ALTRONICS TOLL FREE 008 • 999 • 007 FOR NEXT DAY JETSERVICE DELIVERY

ALTRONICS

COMPONENTS

9th Birthday Sale

• Hundreds of Quality Electronic
Save up to 50% on
Credit Cards accepted — You don't pay a



STATE OF THE ART TOROID POWER TRANSFORMERS

NEW FOR '85



ALL WITH 240V PRIMARY

For the same price as your common garden heavy, bulky, buzzing iron (any old iron at that!) transformer you can now design in a superb Toroid Power Transformer from Altronics.

Why a Toroid?

- Smaller size and weight to meet modern "Slimline" requirements.
- Low electrically induced noise demanded by compact equipment.
- High efficiency enabling conservative rating whilst maintaining size advantages.
- Lower operating temperature.
- Simple, quick single bolt mounting.

Cat No.	Sec V	VA	Es.	10Up
M 3050	12V + 12V	160W	45.00	43.50
M 3080	25V + 25V	160W	45.00	43.50
M 3085	30V + 30V	160W	45.00	43.50
M 3070	35V + 35V	160W	45.00	43.50
M 3075	40V + 40V	160W	45.50	43.50
M 3080	45V + 45V	160W	45.60	43.50
M 3085	12V + 12V	300W	55.00	52.50
M 3088	25V + 25V	300W	55.00	52.50
M 3090	30V + 30V	300W	55.00	52.50
M 3092	35V + 35V	300W	55.00	52.50
M 3100	40V + 40V	300W	55.00	52.50
M 3105	45V + 45V	300W	55.00	52.50

The toroidal transformer is now accepted as the standard in industry, overtaking the obsolete laminated type. Industry has been quick to recognise the advantages toroids offer in size, weight, lower radiated field and, thanks to Altronics—Low Price.

DIMENSIONS

Diameter 110mm
Height 42mm (160VA Models)
52mm (300VA Models)
Leads 200mm length

Highly Recommended For:

- Audio Amplifiers
- Power Supplies
- Microprocessor/computer equipment

MANUFACTURERS AND BULK USERS PLEASE CONTACT OUR WHOLESALE DEPT. FOR BULK QUANTITY RATES.

Made in UK Quality



Checks audio & RF circuits
Signal Tracer for Trouble—Shooting
(See EA Aug. '85)



This simple signal tracer makes a valuable servicing aid and can be used to trouble-shoot both RF and audio circuits. It features an RF probe, battery operation and an in-built loudspeaker

K 2560
\$19.50

Low-Cost Unit Checks Values from 1pF to 100uF
Upgraded digital Capacitance Meter



Cat K 2522
\$69.00

Digital Capacitance Meter Checks capacitor values from 1pF to 99.99uF over three ranges. Features include a nulling circuit and bright 4-digit LED display. (See EA Aug. '85)

The readout consists of a bright 4-digit LED display and the full scale readings for each range are 9999pF, 999.9nF and 99.99uF. No adjustments are necessary when taking a reading. You simply connect the capacitor to the test terminals and select the appropriate range. The circuit can accurately measure capacitance down to one picofarad (1pF). This is made possible by the internal nulling circuit which cancels any stray capacitance between the test terminals or test leads. So when you measure a 5pF capacitor, the unit will display 5pF.

EA'S LABORATORY POWER SUPPLY
3—50 Volt at up to 5 Amps

Single Printed Circuit Board construction - dead easy to build.

SPECIFICATIONS:

- Output Voltage = 3-50 volts
- Output current up to 5 amps (max.175W)
- Floating outputs isolated from ground
- Ripple less than 90mV p.p. at Max.

EXCLUSIVE TO ALTRONICS:

- Deluxe instrument case.
- Attractive silk screened front panel.
- Fully drilled and punched chassis-no holes to drill

K 3300

\$139.50



240V Mains Power From Your 12V Battery
300 Watt Inverter with Auto Start

(See EA Sept. '85)

Just think how handy it would be to have 240 Volt AC Mains Power when camping, or for your Boat or Caravan — well this brilliant new design from Leo Simpson and the design team at Electronics Australia is the answer



- Super Compact - Kit is supplied in Altronics H 0482 Tough ABS Case.
- Uses High Efficiency Toroid Transformer thus keeping down heat dissipation, battery drain and weight.
- Auto Start draws power from your battery only when appliance is plugged in and "turned on" i.e. battery can be left permanently connected if desired.
- Thermal Over Load automatically shuts down if/when output stage is overheated (through high ambient temperature and high load or combination thereof — Automatic reset).
- Current Regulated Indicates inverter is being used within designed load limits.
- Current Overload unit self limits — LED indicates overload condition. Single P.C. board construction — easy to build as there is very little internal wiring.

Complete Kit K 6752 **\$199.00**
Fully Built and Tested K 6754 **\$249.00**

Super Low Price on Famous EA 8 Sector Alarm System Kit
(See EA Mag. Jan '85) **NOW AN INCREDIBLE \$99**

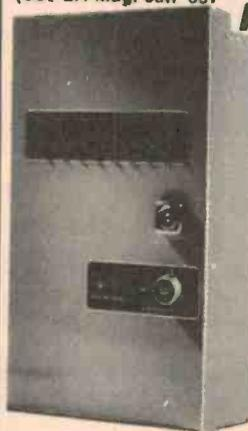

FEATURES:

- Alarm has 8 separate input circuits—8 sectors can be monitored independently.
- Each input circuit is provided with an indicator LED and a sector On/Off switch
- Individual sector isolation allows the user to have some areas of the premises habited while others remain protected e.g. Inside Off/Outside On.
- Inputs accept both normally closed and normally open sensors
- Two Inputs provided with an entry delay (between 10 - 75 seconds)
- Internal trip warning buzzer—alerts owner/occupant of pending alarm operation—great for the "forgetful" amongst us. This buzzer is pre-settable between 5 and 55 seconds prior to Alarm.
- Unique circuit detects automatically when any N/O or N/C loops are either open circuit or dead short. e.g. someone trying to bridge reed switches etc.
- Switched output can be used to send a silent alarm through an auto-dialler circuit or similar.
- Full battery back up provided via. 12V—1.2Ah battery
- Supplied in an attractive functional security case.

K 1900 (without Backup Battery) **\$99**
S 5065 12V 1.2AH Backup Battery **\$22.95**

BANKCARD HOLDERS—PHONE ALTRONICS TOLL FREE 008 • 999 • 007

Bonanza

Components and Products —
our Competitors prices.

cent until you get your statement next month!

Just Arrived

— Ultrasonic Insect and Pest Repeller

PESTREPELLER is effective in controlling mice, rats, roaches, flees, flies, crickets, silverfish, waterbugs, moths, ants, and most other common pests. Laboratory research has shown ultrasonic sound waves attack the auditory and nervous systems of most common pests causing them pain and discomfort. 130 decibels of sound waves are out of the range of hearing of humans and most household pets such as dogs, cats fish and birds, and farm animals.

Specifications—Dimensions: 100 x 90 x 80 Power Supply adaptor supplied 240/9V Frequency Range 30KHz to 65KHz variable Output Level 130db Cat A 0083 **\$49.50**



Build this Fantastic New Kit
NO COMPROMISE DESIGN
Ultra Fidelity
Series 200 Mosfet
Integrated Amplifier



\$439

INCREDIBLE VALUE

FEATURES: — This brilliantly designed stereo amplifier will equal or better just about any integrated commercial amp regardless of price. It is a no-compromise design capable of delivering 100 watts per channel at very low distortion. Four basic stereo inputs are provided for both moving magnet and moving coil cartridges. Also three high level stereo inputs are provided for compact disc players, AM/FM tuner and auxiliary input which could be from a stereo TV tuner of HI FI VCR. Input facilities are also provided for two stereo cassette decks and full monitoring facilities are available for either deck plus dubbing from Deck 1 to Deck 2 or vice versa. • Full CMOS Analog switching (soft touch) • Twist Type speaker lead binding posts supplied • De-thump muting in-built • All Hi-Spec low noise IC's used.

• Incredibly accurate RIAA equalisation. • No control wiring whatsoever • Led indication of switch status (on/off) • All components mount on the PCB, even pots and sockets • Super efficient Toroidal Transformer—Low Hum • Uses Hitachi Mosfet Power devices • In-built over drive protection • Centre detents on Bass, Treble and Balance controls; multiple detents on volume control. • Heavy Duty Heatsinks.

SPECIFICATIONS: —
Power Output: 100W RMS into 8 Ohms (per channel) Freq. Response: 8Hz to 20KHz +0 -0.3db 2.8Hz to 65KHz +0 -1db Input Sensitivity: 0.775mV for full power Hum: -100db below full output S/N Ratio: 94db flat -100db A-weighted Distortion: 0.01% @ 1KHz Stability: Unconditional Cat K 5030

Dear Customer
Don't forget to tell us where
you saw this advertisement — we'll
be delighted to send you the bonus free
offer mentioned at the beginning of the ads.



ALTRONICS COMPONENTS

105 STIRLING STREET, PERTH
FOR INSTANT SERVICE
PHONE ORDER TOLL FREE
008 999 007
PERTH METRO AND A/HRS
(09) 328 1599

ALL MAIL ORDERS
Box 8280, Stirling St. Perth WA 6000
PACKING & DELIVERY CHARGE
\$3.00 DELIVERY AUSTRALIA WIDE
— We process your order the day received and despatch via. Australia Post. Allow approx. 7 days from day you post order to when you receive goods. Weight limited 6Kgs.
\$5.00 OVERNIGHT JETSERVICE — We process your order the day received and despatch via. Overnight Jetservice Courier for delivery next day Country areas please allow additional 24-48 hours. Weight limit 3Kgs.

\$10.00 HEAVY HEAVY SERVICE — All orders of 6Kgs. or more must travel Express Road — Please allow 7 days for delivery.
INSURANCE — As with virtually every other Australian supplier, we send goods at consignees risk. Should you require comprehensive insurance cover against loss or damage please add 1% to order value (minimum charge \$1). When phoning please request "Insurance".
TOLL FREE PHONE ORDER — Bankcard Holders can phone order toll free up to 6pm Eastern Standard Time. Remember with our Overnight Jetservice we deliver next day.

ALTRONICS RESELLERS
Wanted in all Areas of Australia—Phone Steve Wroblewski on (09) 381 7233 for Details.

VICTORIA	NSW	TOWKLEY	SA
CITY Active Electronics 602 3499 All Electronic Components 662 3506 MaGraths Electronics 347 1122 SUBURBAN BENTLEIGH Absolute Electronics 557 3971 BOX HILL SOUTH Eastern Communications 288 3107 CHELTENHAM Talking Electronics 550 2386 DONCASTER Clipstone Electronics 84 2868 FOOTSCRAY Acron Electronics 689 1911 SOUTH CROYDEN Truscott Electronics 723 3860 COUNTRY BENDIGO K.G. Johnson 41 1411 MORWELL Morwell Electronics 34 6133 ROBINVALE John Mason Electronics 26 3643 SHEPPARTON GV Electronics 21 8866	Shop 872 4444 CORCOWOOD Jaycar 745 3077 GORE HILL Jaycar 439 4799 HURSTVILLE Jaycar 570 7000 LEWISHAM PrePak Electronics 569 9770 ORCUNTRY ALBURY Webb's Electronics 25 4066 BATHURST The Electronics 31 4421 BROKEN HILL Crystal TV 4803 COFFS HARBOUR Coffs Harbour Electronics 52 5684 GOSFORD Tomorrows Electronics 24 7246 KURRI KURRI Kurni Electronics 37 2141 NEWCASTLE D.G.E Systems 69 1625 George Brown & Company 69 6399 NOWRA Southern Communications 21 4011 ORANGE MW Electronics 626 491 PORT MACQUARIE Neil of Electronics 83 7440 RAYMOND TERRACE Alback Electronics 87 3419 RICHMOND Vector Electronics 78 4277 TAMWORTH Lindina Communications 65 4622 TENTERFIELD Nathan Ross 36 2204	TES Electronics 96 4144 WINDANG Medjens Electronics 96 5066 WINDSOR M & E Electronics Communications 77 5935 WOLLONGONG Newtek Electronics 27 1620 Vincom Electronics 28 4400	CITY Force Electronic 212 2672 Protronics 2123111 Gerard & Goodman 232222 SUBURBAN BRIGHTON Brighton Electronics 296 3531 CHRISTIES BEACH Force Electronics 382 3366 PROSPECT Jensen Electronics 269 4744 REYNELLA Force Electronics 381 2824 COUNTRY MT. GAMBIER South East Electronics 250 034 PT. LINCOLN West Coast Electronics 82 5802 WHYALLA Eye Electronics 45 4764 TASMANIA HOBART D & I Agencies 34 7877 George Harvey 342233 LAUNCESTON George Harvey 31 6533 Wills Electronics 31 5688 LEGA Frank Beech Electronics 301379 WA COUNTRY ALBANY BP Electronics 41 2681 ESPERANCE Esperance Communications 71 3344 GERALDTON K B Electronics & Marine 21 2176 KALGOORLIE Todays Electronics 21 2777 MANDURAH Kentronics 35 3227 WYALKATCHEM D & J Pease 81 1132

THE EVER POPULAR MUSICOLOUR IV

Combination Colour Organ and Light Chaser. Four channel colour organ. Internal microphone or connect to speakers for colour organ operation. (The lights connected to each channel pulse in beat to the music proportional to portion of frequency spectrum concerned). Four chaser modes forward and reverse. Output lamp load capacity a massive 2400 watts—that's 100 party guitars. Full instructions and every last nut and bolt included. Great for parties, shop signs, display windows etc.



Cat 5800
\$89.00

FOR NEXT DAY JETSERVICE DELIVERY
BANKCARD HOLDERS — PHONE ALTRONICS TOLL FREE 008 • 999 • 007

Low-cost 20 MHz digital scope

A low cost digital storage oscilloscope with 20 MHz sampling rate which also provides full analogue or 'direct display' operation has been introduced by Philips Test & Measuring Instruments. The PM 3302 features a 2 x 2 Kbyte memory and offers many analogue instrument facilities in digital mode, including x-y display.

Sensitivity ranges from 1 μ V to 20 V per division, extending to 200 V/division using standard probes delivered with the instrument.

The PM 3302 combines the advantages of digital storage such as pretrigger, single shot and optional data output with the ability to switch to direct display for use as a conventional 20 MHz analogue two-channel oscilloscope.

In digital mode, the incoming data is stored in a memory with a second memory available to hold reference signals.

For further information contact Philips, 25-27 Paul St, North Ryde, NSW 2113. (02)888-8222.

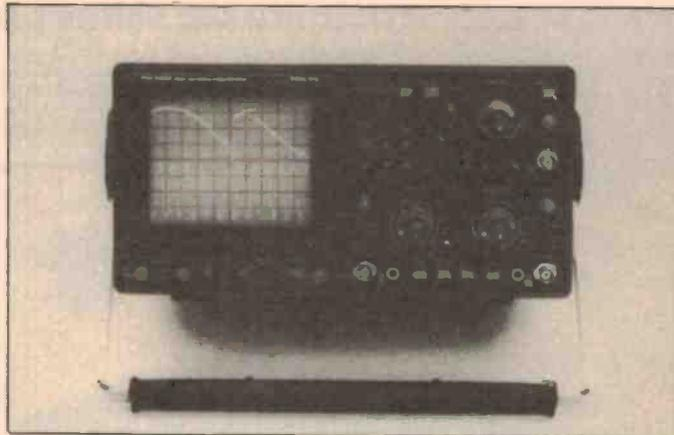

Digital multimeters

Tabor Electronics digital multimeters, models DMM 4120/4121/3121 consist of a single printed circuit board to provide easy access to each component from both sides.

The DMMs are housed in a metal case which protects their circuitry from mechanical damage and provides very good emi shielding.

The input circuitry of the DMM 4120/4121/3121 withstands voltages up to ± 1200 V which may be continuously applied in all Vdc ranges. The ac voltage ranges are protected up to input voltages of 750 Vrms.

Other features of these instruments include current measurements up to 16 A, maximum resolution of 10 nA; resistance measurements up to 20 Mohms maximum resolution of 10 milliohms; and an extremely bright 7-segment LED display with a numeral height of 11 mm.

Available options include a built-in charging power supply and battery holder; a built-in calibrator for complete self check and field calibration; fully parallel BCD data output; IEEE bus adaptor; and analogue output.

For further information contact Paton Electronics, 90 Victoria St, Ashfield, NSW 2131.

GHz spectrum analyser

Vicom has released what it claims is the most advanced low-cost portable spectrum analyser on the market today.

The new spectrum analyser, manufactured by IFR of the USA, incorporates two powerful microprocessors, is menu-driven and uses a digitised vertical raster scan as a display. This system allows the operator to view most analyser parameters simultaneously while monitoring an active or stored trace.

To further enhance the operational simplicity of the analyser, the microprocessor system automatically selects and optimises the analyser's bandwidth, sweep rate, centre frequency display

resolution and the rate of the frequency flying keys.

The A-7550 has 1 GHz frequency coverage, digital storage, automatically scaled electronic graticule, automatic amplitude calibration, video filters, line, bar average and compare display mode and internal battery system.

Options offered include tracking generator, FM/AM/SSB receiver and a quasi peak detector. IEEE 488 or RS232 interfaces will also be available as options together with the transit cases, locally made in Australia.

For more information, contact Vicom offices in Sydney, Melbourne and Brisbane.

Audio analysers for broadcast and transceiver testing

Two new products for audio analysis from Hewlett-Packard, the HP 8903B audio analyser and HP 8903E distortion analyser, enhance measurement capabilities in the broadcast and transceiver test marketplace.

The two analysers have performance ac voltmeters; fully automatic distortion analysers;

dc voltmeters; SINAD meters; and audio-frequency counters.

Not only an analyser, the HP 8903B also has an audio source capable of swept measurements down to -90 dB. The analyser can measure swept frequency response deviations as small as 0.01 dB. The more economical HP 8903E, with only audio-

measurement functions, has been developed for customers who already possess an audio source but are in need of sensitive test capabilities.

Both analysers can handle input signals up to 300 volts differentially. With balanced audio input, the instruments can directly measure bridged ampli-

fiers and professionally balanced audio equipment.

Both HP 8903B and HP 8903E have two internal plug-in filter positions, which can be loaded with any of six optional filters.

A new composite input op-amp gives both instruments a much lower noise floor than the HP 8903A. Noise is specified at the higher of -85 dB or 17 microvolts in an 80 kHz bandwidth.



HEWLETT
PACKARD

and
present



PC INSTRUMENTS COMPETITION

\$1726.00 in prizes!

Hewlett Packard has shown how innovative it can be with the release of the PC Instruments system. Now its your turn! If you can suggest the four most innovative applications for the PC Instruments system you can be in the running to win a high performance multimeter or one of two great programmable calculators.

You could win this high performance HP 3468B five function digital multimeter. It has 1 uV sensitivity and electronic calibration.

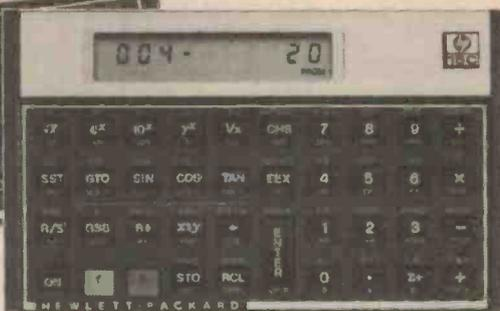
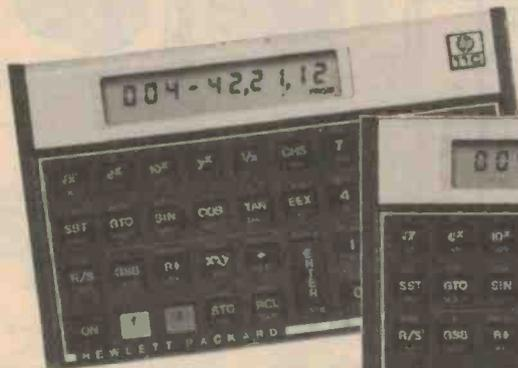
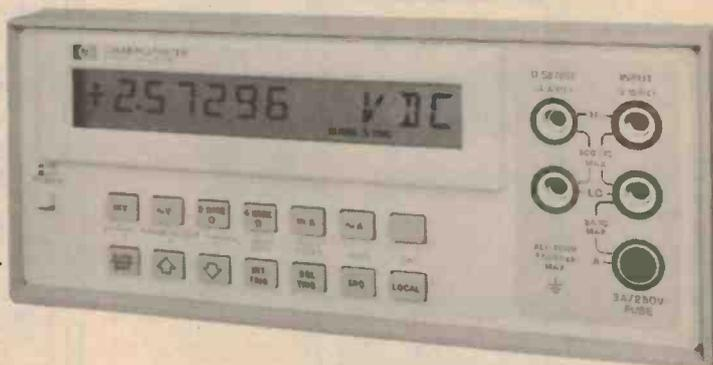

Or you could win one of these two runner up prizes, a HP 11C or a HP 15C scientific programmable calculator.

Closes November 1, 1985

Yes! Please enter me in the HP-ETI-PC Instruments Competition . . .

I think the four most innovative applications for the PC Instruments would be:

1..... Name:

..... Address:

2..... Postcode.....

..... State..... Phone

3..... Company/Organization

4.....

eti The Federal Publishing Company Pty. Ltd.
P.O. Box 227,
Waterloo, N.S.W. 2017.

Take advantage of Rod prices, extensive range,

NEW PHONE PLUGS & SOCKETS

We hear on the grapevine that all future installation will use the U.S.A type of plug and sockets for communication lines.



TELEPHONE CURL CORD
 • U.S. plug to U.S. plug
 • Replacement hand set cord
 • Length 4.5 metres
 • Colours: cream, dark brown
 Cat. Y16022 \$7.95



TELEPHONE NEW! EXTENSION CABLE
 • U.S. plug to U.S. socket
 • Length 10 metres
 • Cream colour cable
 Cat. Y16024 \$8.95



• Australian plug to U.S. socket
 • Length 10cm
 • Cream colour cable
 Cat. Y16026 \$6.95



TELEPHONE NEW! EXTENSION CABLE
 • U.S. plug to 2 U.S. sockets
 • Length 10 metres
 • Cream colour cable
 Cat. Y16028 \$10.95

AUSTRALIAN TYPE COMMUNICATION PLUGS/SOCKETS
 We still have great stocks of Australian type phone plugs and sockets!



TELECOMMUNICATION PLUG TO 2 SOCKETS
 Ideal for modem connections
 Cat. Y16014 \$12.95



TELECOMMUNICATION PLUG/SOCKET
 Plug Cat. Y16016 \$3.95
 Socket Cat. Y16018 \$4.95

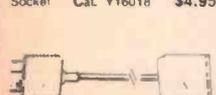

TELECOMMUNICATION EXTENSION LEADS
 5m \$12.50
 10m \$14.95



TELEPHONE NEW! EXTENSION CABLE UNIT
 Allows 15 metres of telephone extension cable to be neatly wound into a portable storage container. The reel sits on a squared off base and the reel has a handle to wind cable back on to it after use. No tangles - no mess! Ideal for the workshop, around the house, office, pool etc.
 Cat. Y16013 \$24.95



TELEPHONE INDUCTION COIL
 For recording or amplification.
 3.5mm plug with 3 metre cord
 Cat. A12035 \$3.95



TDK VIDEO TAPES AT BARGAIN PRICES!
 VHS
 E60 \$12.50
 E120 \$12.50
 E180 \$11.80
 E240 \$22.40
 BETA
 L250 \$13.50
 L500 \$14.40
 L750 \$15.50



VIDEO PROCESSING CENTRE
 Combination stabilizer, enhancer, distribution amplifier, RF converter designed to enhance all recording needs. Will handle 3 VCR's simultaneously with virtually zero signal loss. Built in RF converter permits in-line connection between VCR and TV for improving recording whilst viewing.



Specifications:
 Power Requirements 12V DC 300mA
 Inputs Video, Audio
 Outputs 3 video 3 audio
 RF UHF Channel 36
 Output Level 0-30dB
 Output Isolation More than 40dB
 Audio Outputs Unity gain
 Input Output 75 ohms
 • PP300 recommended power source
 Cat. A13012 only \$159



YFE 1030C DIGITAL MULTIMETER
 New multimeter at unbeatable value for under \$60! The new YU-FONG YFE-1030C features:
 • Large 3 1/2 digit display (1.2 inch high)
 • Autopolarity, "-" display for Negative input
 • High over-load protection for all ranges
 • Over-load display highest figure "1" or "1.1" alone glows
 • Power consumption 20mW approx.
 Cat. O16030 \$59.95



DESK MOUNTED LAMP MAGNIFIER
 This unit magnifies any object under a clear cool fluorescent light. The magnification is the maximum obtainable (lens 127mm diameter biconvex 4 Dioptres, focal length 254mm) consistent with minimum distortion and eye strain and good off-angle viewing. It is NOT cheap but then again it will definitely last a lifetime. It is built like a Rolls Royce! Spare fluoro tubes are available from electrical outlets. If you have trouble with fine PCB work or component identification but still want both hands free, this is for you.
TECHNICAL INFORMATION
 Illumination: 22W Fluorescent
 Weight: 816g
 Lateral Extension: 254mm
 Vertical Extension: 254mm
 Fitting: Heavy table base (grey) with two chrome plated flexible arms
 Cat. C9270 \$169



MEMCON CRAWLER
 The latest in our range of robots! Programmable 3 wheel crawler with on board RAM. Programs entered by detachable keyboard.
 Cat. K96686 Only \$79.95



PIPER MOUSE ROBOT
 This is a Super-Sonic robot, controlled by a super-sonic sound sensor and an electronic circuit. (1 Channel). By using the whistle included with this kit, Piper Mouse will obey your commands immediately turning to the left, stop, turning to the right, stop, advance and stop.
 Cat. K96680 \$44.95

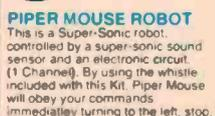

QUARTZ CRYSTAL CLOCK MOVEMENT
 • Very compact and reliable
 • Self starting one second stepping
 • Stepping motor has storage torque
 • Powered by 1.5V AA battery that lasts approximately a year
 • Supplied with two sets of hands, one short and one long
 • 15 seconds month accuracy
 • 56mm square 15mm deep
 Complete with data sheet instructions and wall hanger bracket.
 Cat. X90100 \$14.95



TDK LINE FILTERS
 240 V 3A
 Cat. X90100 \$12.50

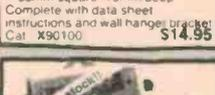

MODEM PHONE
 Check the features and the value for money of this stylish new modem phone...
 • Auto/Manual Answer, Manual Originate, Auto Disconnect
 • Carrier Detect Indication, 20 Memories (each with 18 Digits Capacity) for Auto-dialing
 • BELL 103 CCITT V21 Compatible
 • 300 BPS Full Duplex
 • Last Number Redial
 • Pushbutton Keyboard
 Cat. X19105 \$199
 (Not Telecom approved)



RITRON 2
 Stylish semi-base monitor, available in amber or green.
 Green Cat. X14500 \$215
 Amber Cat. X14500 \$219

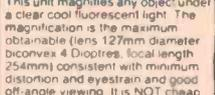

S100 PROTOCOL CARDS
 Horizontal Bus Cat. H19125 \$39.50
 Vertical Bus Cat. H19130 \$39.50
 Pad per Hole Cat. H19135 \$39.50



SAVE \$30!
APPLE* COMPATIBLE SLIMLINE DISK DRIVE
 Japanese Chiron mechanism
 Normally \$225 this month \$195
 (*Apple is a registered trade mark.)



SPECIAL!
5 1/4" FLOPPY DISK SPECIALS!
 XIDEX 1-9 10+
 S/D/D/D \$31.00 \$29.00
 Cat. C12401
 D/S/D/D \$38.00 \$36.50
 Cat. C12410
VERBATIM DATALIFE
 S/D/D/D \$27.95 \$26.95
 Cat. C12501
 D/D/D/D \$39.95 \$37.95
 Cat. C12504
VERBATIM VALULIFE
 S/D/D/D \$24.95 \$22.95
 Cat. C12421
 D/D/D/D \$31.95 \$29.95
 Cat. C12425



IBM* COMPATIBLE COMPUTER
 Incredible deals to suit everyone! All include colour graphics card, multi function card, disk controller, card, 2 serial and 1 parallel ports. Your choice of 256K or 640K and the option of our special "package deals" which include a 120 C.P.S. printer and a monochrome monitor, all available at incredible prices including a 3 month warranty!



DIGITAL MULTIMETER YFE YF1100 FEATURES
 • Large easy to read 3 1/2 digit display
 • Facilities for transistor and diode testing
 • Clearly laid out front panel
 • 10A DC AC range
 • Priced to undersell the others
 Cat. Q16025 \$89.95

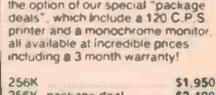

CRYSTALS SPECIALS
 Prime Specs. We just have too many in stock!
 Description Cat.No. 1-9 10+
 1MHz Y11000 \$7.50 \$6.50
 1.8432MHz Y11003 \$7.50 \$6.50
 4MHz Y11020 \$2.50 \$2.00
 4.194304MHz Y11022 \$2.50 \$2.00
 4.433618MHz Y11023 \$2.50 \$2.00
 4.75MHz Y11025 \$2.50 \$2.00
 4.915200MHz Y11026 \$2.50 \$2.00
 5MHz Y11030 \$2.50 \$2.00
 6MHz Y11040 \$2.50 \$2.00
 6.1444MHz Y11042 \$2.50 \$2.00
 6.570MHz Y11045 \$2.50 \$2.00
 8MHz Y11050 \$2.50 \$2.00
 8.867238MHz Y11055 \$2.50 \$2.00
 10MHz Y11060 \$2.50 \$2.00
 12MHz Y11070 \$2.50 \$2.00
 14.31818MHz Y11072 \$2.50 \$2.00
 15MHz Y11075 \$2.50 \$2.00
 18MHz Y11082 \$2.50 \$2.00
 18.432MHz Y11085 \$2.50 \$2.00
 20MHz Y11090 \$2.50 \$2.00



SUPER HORN TWEETER
 • Requires no crossover and handles up to 100W!
 • Sensitivity 100dB/0.5m
 • Frequency Response: 3kHz-30kHz
 • Impedance: 8 OHMS
 • Size: 145x54mm
 Cat. C12102 ONLY \$14.95

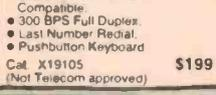

SUPER HORN
 • Wide dispersion tweeter, handles up to 100W.
 • Sensitivity 105dB/0.5m
 • Frequency Response: 3kHz-30kHz
 • Impedance: 8 OHMS
 • Size: 145x54mm
 Cat. C12103 \$14.95



5mm PRIME SPEC LEDS!
 1-9 10+
 Red Cat. Z10150 10c 10c
 15c 12c 10c
 Green Cat. Z10151 25c 18c 12c
 Yellow Cat. Z10152 25c 18c 12c



WE'RE OVERSTOCKED!
8000 SERIES IC SPECIALS!
 For 1 month only, we are offering these IC's at special low prices!

1-9 10+
 8085 4.50 3.50
 8212 1.50 1.40
 8216 1.50 1.40
 8226 1.70 1.50
 8243 4.50 3.90
 8251 3.90 3.50
 8253 3.50 3.30
 8255 2.90 2.50
 8257 3.50 3.10
 8259 3.50 3.10
 8279 3.50 3.10
 2532 7.50 6.90
 2764 5.50 5.10
 27128 7.50 6.90
 1488 55 45
 1489 55 45

MSM5832 BACK IN STOCK!
 1-9 10+
 \$12.50 \$11.50
6116P-3 PRICES SLASHED!
 1-9 10+
 \$2.75 \$2.50



P.A. SPEAKERS
 Low dual cone, wide range, 200mm (8in.) ideal for public address, background music, etc. Tremendous Value at these prices!
 Cat. C12000 1-9 10+
 \$6.95 \$5.95

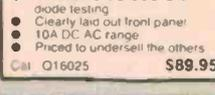

COMPUTER CASSETTES
 Quality 20 minute tapes.
 Cat. D11141 1-9 10+ 100+
 \$1.50 \$1.40 \$1.20



SAVE

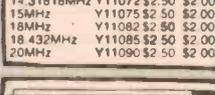

NEW!

Irving Electronics' great and quality service!

DIRECT IMPORT



SOLDER CENTRONICS PLUGS
 Unreal price for absolute top quality
 Normally \$14.95 (Our opposition charge up to \$19.95)

1-9	10-	100+
\$4.95	\$4.50	\$3.95



CANNON TYPE AUDIO CONNECTIONS
 We've sold 1000's because of their great value!!

3 Pin line male	1-9	10+
Cat. P10960	\$2.90	\$2.80
3 Pin chassis male		
Cat. P10962	\$2.90	\$2.50
3 Pin line female		
Cat. P10964	\$3.50	\$2.90
3 Pin chassis female		
Cat. P10966	\$3.90	\$3.20

NEW!



UV EPROM ERASER
 Erase your EPROMs quickly and safely. This unit is the cost effective solution to your problems. It will erase up to 9 x 24 pin devices in complete safety, in about 40 minutes (less for less chips).

Features include:

- Erase up to 9 chips at a time
- Chip drawer has conductive foam pad
- Mains powered
- High UV intensity at chip surface ensures EPROMs are thoroughly erased
- Engineered to prevent UV exposure
- Long life UV tube
- Dimensions: 217 x 90 x 68mm
- Weight 670 grams

Cat. X14950 **\$89.50**



36 WAY CENTRONICS CRIMP PLUG
 Cat. P12200

1-9	10-99	100+
\$7.95	\$7.50	\$7.25

RS232 & 'D' TYPE CONNECTORS

PART	DESCRIPTION	CAT. No.	10+
DE 9P	9 Pin Female	P10880	\$1.75
DE 9S	9 Pin Male	P10881	\$2.25
DE 9C	9 Pin Cover	P10992	\$2.55
DA 15P	15 Pin Male	P10894	\$2.10
DA 15S	15 Pin Female	P10895	\$2.25
DA 15C	15 Pin Cover	P10892	\$1.15
DB 25P	25 Pin Male	P10900	\$2.95
DB 25S	25 Pin Female	P10901	\$3.45
DB 25C	25 Pin Cover	P10902	\$1.20

NEW COMPUTER PRODUCTS!

NEW!



RS232 MINI PATCH BOX
 • Interface RS232 devices
 • With male to female 25 pin inputs
 • 25 leads with tinned end supplied
 • Complete with instructions

Cat. X15654 **\$25.95**

RS232 GENDER CHANGERS
 • Saves modifying or replacing non-mating RS232 cables by changing from male to female to male
 • All 25 pins wired straight through

NEW!



Male to Male
 Cat. X15650 **\$19.95**

NEW!



Female to Female
 Cat. X15652 **\$19.95**

NEW!



RS232 MINI TESTER
 • Male to female connections
 • All pin wired straight through
 • Dual colour LED indicates activity and direction on 7 lines
 • No batteries or power required

T.D. Transmit Data
 D.S.R. Data Set Ready
 R.D. Receive Data
 C.D. Carrier Detect
 R.T.S. Request to Send
 D.T.R. Data Terminal Ready
 C.T.S. Clear to Send

Cat. X15656 **\$39.95**

NEW!



RS232 SURGE PROTECTOR
 • Avoids costly damage from large voltage peaks caused by lightning or other power problems
 • Uses metal oxide varistors (M.O.V.) to suppress any voltage above 26V on pins 2,3 and 7
 • Will handle up to 1 Joule and 250A peak current

Cat. X15660 **\$34.95**

NEW!



RS232 NULL MODEM ADAPTOR
 • Male to female connections
 • Pins 2 and 3 reversed
 • All 25 pins connected

Cat. X15658 **\$19.95**

BANK AS SUPPLIED IN ARCADE GAMES!



4 WAY DIRECTIONAL JOYSTICK
 Cat. X15635 **\$29.95**

NEW!



AUTOMATIC ANTENNA ROTATOR
 • Fully automatic with 50kg vertical load
 • Suits most TV, FM, VHF & UHF antennas
 • Fully approved by the Energy Authority

SPECIFICATIONS:
 Rotation: 360° with mechanical stop
 Rotation Time: 360° in 70 seconds
 Mast Size: 22 to 40mm Ø diameter
 Loading: 50kg vertical
 0.25m Ø 25m wind
 Weight: Drive unit 3.1kg
 Size: 152x375(H)mm

Cat. A12069 **only \$99.50**



COMPUTER AND DISK DRIVE CASES AND POWER SUPPLIES

5 1/4" DRIVES

1 x 5 1/4" Slimline Drive Case X11001 Bare Case	\$49
X11011 Case and Pwr Supply	\$109
2 x 5 1/4" Slimline Drive Case X11001 Bare Case	\$69
X11012 Case & Pwr Supply	\$149
1 x 5 1/4" Standard Drive Case X11003 Bare Case	\$39
X11013 Case & Pwr Supply	\$109
2 x 5 1/4" Standard Drive Case X11004 Bare Case	\$59
X11014 Case & Pwr Supply	\$149

8" DRIVES

1 x 8" Standard or 2 x 8" Slimline and computer Case (BB1) X11006 Bare Case	\$99
X11016 Case & Pwr Supply	\$395
2 x 8" Slimline Drives and Computer Case (BB1 and BB2 etc) X11007 Bare Case	\$145
X11017 Case & Pwr Supply	\$395
1 x 8" Slimline Drive Case X11020 Bare Case	\$95
X11022 Case & Pwr Supply	\$159
Dual 8" Slimline Drive Case X11025 Bare Case	\$99
X11026 Case & Pwr Supply	\$279



BRAND NEW FANS
 Not noisy pullout! Stacks of uses in power amps, computers, hotspot cooling etc. Anywhere you need plenty of air.

240V 45w	Cat. T12461	\$12.95
115V 45w	Cat. T12463	\$12.95
240V 31/2"	Cat. T12465	\$12.95
115V 31/2"	Cat. T12467	\$12.95
10 Fans (mixed) less 10%		

AUSTRALIAN MADE



HIGH EFFICIENCY RADIAL FIN HEATSINK
 Black anodized with a thick base plate, this radial fin heatsink can dissipate large amounts of heat for maximum efficiency.

105x85mm Cat. H10524	\$ 2.80
105x75mm Cat. H10525	\$ 3.00
105x150mm Cat. H10535	\$ 5.50
105x225mm Cat. H10546	\$ 8.00
105x300mm Cat. H10549	\$12.00

NEW!



MINI JUMPERS
 • Contact terminal Phosphor bronze
 • Material P.B.T 94V-0
 • Gold plated

Qty	Cat. No.	Price
10	P12053	\$2.95
25	P12055	\$4.95
100	P12057	\$21.95



ECONOMY TRANSFORMERS

2155	1-9	10+
Cat. M12155	\$6.75	\$5.95
2156	\$9.50	\$8.95
Cat. M12156		
2851	\$4.50	\$3.60
Cat. M12851		
6672	\$9.95	\$9.30
Cat. M16672		



PANEL METERS GALORE!
 We have a great range of panel meters at great prices!

Cat.No.	Description	Price
O10500	MU45 0-1mA	12.50
O10502	MU45 0-0.50UA	12.50
O10504	MU45 0-100UA	12.50
O10510	MU45 0-5A	12.50
O10518	MU45 0-1A	12.50
O10520	MU45 0-1mA	12.50
O10525	MU45 0-20V	12.50
O10530	MU5E 0-1A	14.50
O10533	MU5E 0-5A	14.50
O10535	MU45 V P/Meter	14.95
O10538	MU65 0-50UA	16.95
O10540	MU65 0-1mA	16.95
O10550	MU65 0-100UA	16.95
O10560	MU65 0-20V	16.95

WHAT A RANGE!

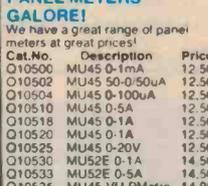

HORWOOD ALUMINIUM CASES
 We have a full range of quality Horwood cases.

Cat.No.	Dimensions	Price
H10382	3x4x2"	\$5.50
H10383	3x4x3"	\$ 6.50
H10384	3x4x4"	\$ 7.50
H10385	3x4x5"	\$ 7.95
H10386	3x4x6"	\$ 8.50
H10387	3x4x7"	\$ 9.50
H10388	3x4x8"	\$10.50
H10389	3x4x9"	\$10.95
H10390	3x4x10"	\$11.95

RECHARGEABLE 12V GELL BATTERIES
 Leakproof and in 3 convenient sizes, these long service life batteries are ideal for burglar systems, emergency lighting or as a computer backup power supply. Ideal for many power needs.

Cat. S15029	12V 1.2 AH	\$12.95
Cat. S15031	12V 2.6 AH	\$39.50
Cat. S15031	12V 4.5 AH	\$49.95

NEW!



UHF/VHF/FM ANTENNA
 Frequency: VHF 48-216 MHz (Ch 1-12)
 UHF 536-764 MHz (Ch 25-62)

Up grade your TV system now before Channel 68 disappears! Includes 75ohm and 300ohm balun, incredible value!!

Impedance: 75-300 (200) Ohm
 Element: VHF 4, UHF 9
 Gain (dB): VHF 4.6, UHF 4.8

Cat. L11014 **Normally \$39.50 NOW \$29.50**



FM ANTENNA
 88-108MHz, 75-300 Ohm

Cat. L11015 **Normally \$29.50 NOW \$19.50**

NEW!



PRECISION INSTRUMENT CASE
 Features vent system for cooling, top and bottom snap together (no screws required), removable front and back panels.

Cat.	Dimensions	Price
H10114	135x93x47mm	\$6.95

BARGAIN



ECONOMY 19" RACK CASE
 Tremendous Value! Dimensions W 480 x H 134 x D 250mm

Cat. H10415	1-9	10+
	\$47.50	\$44.50

WHAT A RANGE!



HORWOOD ALUMINIUM CASES
 We have a full range of quality Horwood cases.

Cat.No.	Dimensions	Price
H10382	3x4x2"	\$5.50
H10383	3x4x3"	\$ 6.50
H10384	3x4x4"	\$ 7.50
H10385	3x4x5"	\$ 7.95
H10386	3x4x6"	\$ 8.50
H10387	3x4x7"	\$ 9.50
H10388	3x4x8"	\$10.50
H10389	3x4x9"	\$10.95
H10390	3x4x10"	\$11.95

BARGAIN



HORN CRAZY!
 BW, aluminium or plastic, Normally \$9.50
 Aluminium Cat. C12015
 Plastic Cat. C12010

1-9	10+
\$6.50	\$5.95

NEW!



UTILITY CASE
 A must for all technicians, hobbyists and handy-men. Features clear plastic lid so you can tell at a glance the contents, up to 48 compartments, adjustable to suit your needs. A place for everything and everything in its place!

Cat. M10449 **\$18.95**

SAVE



WELLER WTCPN SOLDERING STATION
 The WTCPN Features:
 • Power Unit 240 V AC
 • Temperature controlled iron, 24 V AC
 • Flexible silicon lead for ease of use
 • Can be left on without fear of damaged tips!
 The best is always worth having.

Cat. T12500
 R.R.P. \$129 **Our price \$99**

ROD IRVING ELECTRONICS
 425 High Street, NORTHCOTE, 3070 VICTORIA, AUSTRALIA
 Phone [03] 489 8866
 48-50 A Beckett Street, MELBOURNE, 3000 VICTORIA, AUSTRALIA
 Ph. [03] 663 6151

Mail Order and correspondence:
 P.O. Box 620, CLAYTON 3168
 TELEX: AA 151938

MAIL ORDER HOTLINE
 (03) 543 7877
 (2 lines)

POSTAGE RATES

\$1-\$9.99	\$2.00
\$10-\$24.99	\$3.00
\$25-\$49.99	\$4.00
\$50-\$99.99	\$5.00
\$100-\$199	\$7.50
\$200-\$499	\$10.00
\$500 plus	\$12.50

This is for basic postage only. Comex Road freight, bulky and fragile items will be charged at different rates.



NEW!



UTILITY CASE
 A must for all technicians, hobbyists and handy-men. Features clear plastic lid so you can tell at a glance the contents, up to 48 compartments, adjustable to suit your needs. A place for everything and everything in its place!

Cat. M10449 **\$18.95**

MasterCard VISA

Blank order form with fields for Name, Address, P.Code, and a grid for items.

Post Z80 has arrived

The George Brown Electronics Group has announced delivery of 16- and 32-bit processors from Zilog. The 32-bit ones are called the Z80,000. The 16-bit family is the Z8000.

The Z80,000 processor includes a 32-bit instruction set, 32-bit implementation, 32-bit linear or segmented addressing, and 32-bit system bus, plus on-chip cache and memory management.

A heavily "pipelined" (as opposed to common "pre-fetch") architecture lets the Z80,000 CPU process more than one instruction at a time, thus raising CPU performance to up to five million instructions executed per second. Since every stage of the pipeline can process an instruction at every clock cycle, the Z80,000 CPU can execute at a high rate of one instruction per processor clock cycle.

The Z80,000 system architecture increases processing flexibility. Sixteen 32-bit general purpose registers can hold your

choice of either addresses or data. You can choose from nine available addressing modes for the load, arithmetic, logical and boolean instructions to manipulate byte, word or long-word operands.

The 16-bit version of the Z80 is called the Z8002. It directly addresses 64K bytes and has a choice of eight addressing modes and seven data types, ranging from bits to words of 32 bits, to byte and word strings.

The new processor is also capable of 32-bit operations, including signed multiply and divide. It is Z-bus compatible, and can be driven at a 4, 6 or 10 MHz clock rate.

Other members of the family include the Z8000 burst error processor (Z-BEP) which detects and corrects errors for high-

performance, high-speed data transfer; and the Z8060, a general-purpose buffer unit. This works with both Zilog Z8 and Z8000 CPUs. It can be connected in series to form parallel buffers of any length (in 128-byte increments) or width (in 8-bit increments).

The Z8038 is a FIFO/input/output interface unit (Z-FIO). It can reduce I/O overhead by as much as two orders of magnitude. It acts as an asynchronous 128-byte FIFO buffer between dissimilar CPUs, or CPUs and peripherals running under different speeds or protocols.

Another peripheral is the Z8036, which is a versatile, general-purpose peripheral circuit with a number of programmable options to meet specific applications needs.

Serial communications control is done by the Z8030, a dual-channel, multi-protocol serial-to-parallel or parallel-to-serial converter/controller. It supports virtually any serial data transfer application using the Zilog Z-BUS.

Asynchronous serial communications control is done with the Z8031. It is a dual-channel data communications controller with facilities for modem controls in both channels. Like the SCC, it is a serial-to-parallel, parallel-to-serial converter/controller.

For further information contact the George Brown Electronics Group, 174 Parramatta Rd, Camperdown, NSW 2050. (02)519-5855.

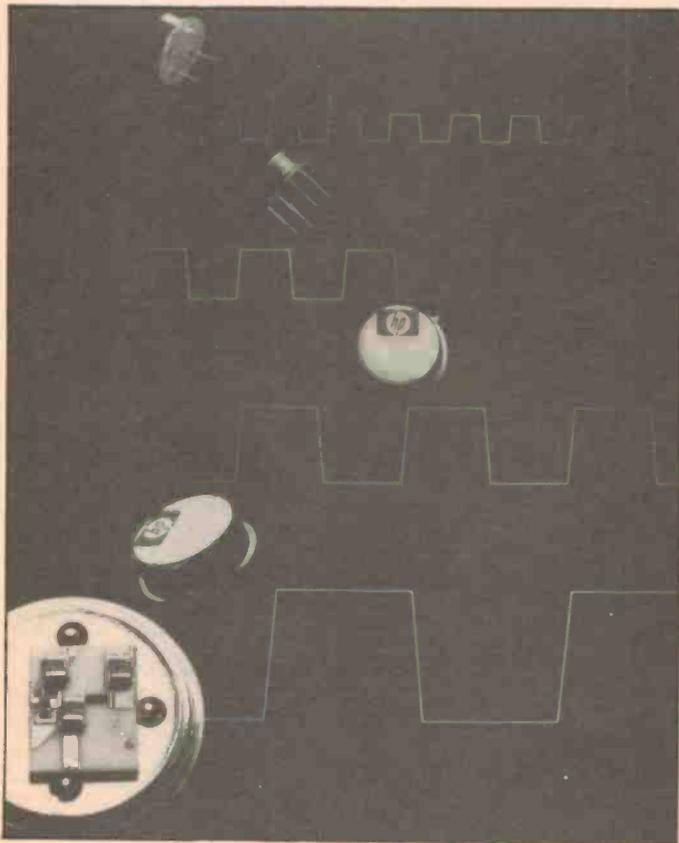

HP hybrids

A new series of hybrid cascaded amplifiers has been introduced by Hewlett-Packard.

HP's introduction of these products signals the company's intention to market components for the broadband, high-speed digital and analogue market.

HP has targeted the new product at the fast-growing area of high-speed digital communications, where speeds range from 400 to 2000 megabits per second. A primary analogue application will be the emerging GPS (global positioning satellite) systems.

The amplifiers use resistive feedback in a Darlington configuration to deliver what is claimed to be exceptional phase linearity over a wide temperature range and broad bandwidth.

The components achieve typical values in gain variation of ± 0.3 dB and provide a phase response with less than two degrees from linear phase over the specified frequency at -55 to

$+85$ degrees C.

Initial parts in this series are packaged in industry-standard, TO-8 metal-glass hermetic packages. They are capable of operating in the range from -55 to $+125$ degrees C and guaranteed for performance at temperatures from -55 to $+85$ degrees C.

HP has introduced four members of its amplifier series: the HAMP-1001 provides typical minimum output power at 1 dB compression) of 12.5 dBm; the 1 dB bandwidth of this amplifier is from 5 to 2800 MHz; the HAMP-1002 and HAMP-1003 general purpose amplifiers offer minimum gain of 9.7 dB. The 1 dB bandwidth of the HAMP-1002 is 5 to 1900 MHz; that of the HAMP-1003 is 5 to 2000 MHz.

With a 1 dB bandwidth of 5 to 1650 MHz, the HAMP-1004 has a maximum noise figure of 4 dB and a typical minimum gain of 12.5 dB.

For further information contact Hewlett-Packard, 17-23 Talavera Rd, North Ryde, NSW 2113. (02)888-4401.

SIL caps

Moulded case, single-in line packaged monolithic multilayer ceramic capacitor networks are primarily intended for use in signal and data processing equipment, where repetitive capacitor values and space and economy are also required.

The capacitor sections are

made by alternately depositing three thin layers of ceramic dielectric material and metallic electrodes; the resultant individual capacitor sections are fired into all but indestructible solid blocks.

Manufacturing and finishing operations are completely mechanised to provide highly reliable low cost devices. Multilayer construction provides a

very high capacitance/volume ratio with a minimum of self inductance. Moulded case construction produces rugged uniform devices suitable for automatic insertion while the single ended design affords significant space savings.

Five circuit configurations are available in standard gradings. Four individual capacitor sections or seven capacitor sections

with one common ground lead are supplied in 8-pin packages. Five individual capacitors, eight capacitors with two common ground leads or nine capacitors with one common ground lead, are supplied in 19-pin packages.

For further information, request Engineering Bulletin 6244 from Sprague Electric, 56 Silverwater Rd, Auburn, NSW 2144. (02)648-1661.

Easy interfacing

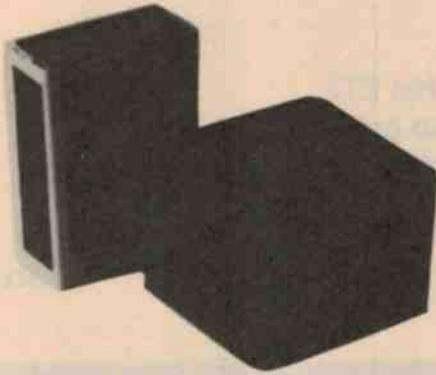

Correct electrical isolation of equipment connected to the telephone network is of paramount importance when applying for a Telecom "Permit to Connect". In the past, bulky HV capacitors, zener diodes and isolation transformers had to be used to achieve required isolation. All these components can now be replaced by a new protective line interface.

The unit is compact enough to be fitted inside any equipment with isolation to 3.5 kV. It has a built-in current and over voltage limiter.

The unit is a true inductive device — 600/600 ohms. As no capacitors are required to achieve line protection, it is especially suited to equipment, performance of which is degraded by capacitive coupling effects, for example high speed modems.

The Protective Line Interface Unit meets Telecom specification 1364 and Telecom Engineering approval no RA 84/152.

For more information contact Intelinc, F8, 62 Wellington Pde, East Melbourne, Vic 3002.

BRIEFS

15 ns PROM

National Semiconductor has introduced a new 256-bit (32 x 8) PROM with a 15 ns access time, designated PL87X288B.

It has five inputs, eight outputs, a fixed AND array generating all 32 product terms and a programmable OR array. Typical power dissipation is 550 mW. The new PROM is fabricated using National's OXISS, oxide-solated bipolar process. For more information contact National Semiconductor at 21/3 High St, Bayswater, Vic 3153. (03)729-6333.

Jumbo LEDs

Telefunken Electronics is now shipping a new 10 mm diameter LED, the TLH-400 series. To achieve high brightness in such a large package, Telefunken employs two high efficiency LED chips on a three lead header. The LEDs are available in red, yellow and green. For more information contact Promark Electronics, PO Box 381, Crows Nest, NSW 2065.

Improved rheostats

IRH Components manufactures the APR series of power wire wound rheostats in three popular power ratings: 25, 50 and 100 watts. Features include "off" position for isolation of the rheostat; fixed tapping; two styles of terminals, solder and 6.3 mm quick connect; and even lower resistance values in all three ratings. For further information contact IRH Components, 32 Parramatta Rd, Lidcombe, NSW 2141. (02)648-5455.

100 MHz A-D

With the SDA 8010, Siemens provides a monolithic integrated analogue-to-digital converter for 8-bit word lengths operating at 100 MHz. The SDA 8010 A-D converter is accommodated in a 24-pin DIL ceramic package. For more information contact Siemens at 544 Church St, Richmond, Vic 3121. (03)420-7204.

64K NMOS

George Brown Electronics now has the 64K F1600 chip available. It is a fully static asynchronous random access memory, organised as 65,536 words by 1-bit, using high-performance CMOS/NMOS technology. The F1600 is based on an advanced isoplanar oxide isolation process, with sub-2 micron design rules and high-performance tantalum silicide interconnects. The high-density NMOS memory array and the CMOS peripheral circuits provide fast access time plus low active and standby power. For further information contact the George Brown Electronics Group, 174 Parramatta Rd, Camperdown, NSW 2050. (02)519-5855.

Ceramic chip capacitors

Kemet catalogue F-20964/85 is now available on multilayer ceramic chip capacitors featuring Solderguard 11. They are available in standard ratings and sizes. Depending on the selected dielectric, these caps can be used in consumer items, in computer and automotive applications and communications circuitry. End metallisation is available in silver when the chips will be attached using conductive epoxy, or nickel barrier when the chip will be soldered in place. The catalogue is available free from Crusader Electronic Components, 81 Princes Hwy, St Peters, NSW 2044. (02)519-5030.

Component problems

British company Grolec is specialising in supplying parts for telecommunications and other products which are no longer in production — particularly those originally made in Britain. In addition to devices such as valves, semiconductors and transistors, Grolec holds extensive stocks of receiving, transmitting or industrial valves as well as integrated circuits, diodes capacitors and resistors, fuses, transformers, and relays made before 1965. Parts are subject to a quality control procedure which covers functional testing and checks correct marking, packing and documentation. For more information contact Grolec Ltd, Stephenson Rd, Gorse Lane Industrial Estate, Clacton-on-Sea, Essex C 15 4XA, England.

LOW DISTORTION AUDIO OSCILLATOR

Part 1

Our gnomes in the market research field have told us that ETI readers are more interested in hi-fi than the average. No great revelation, you probably built your own system? Well this project puts that to the test. It's an audio oscillator that allows you to accurately measure audio performance so you can be more authoritative than the average.

Ian Thomas

JUST ABOUT EVERYBODY in this civilized country of ours has a hi-fi system of some sort or another. Since you're reading this magazine you almost certainly take a more than passing interest in how well it works and have probably built some, maybe all of it yourself. If, like most of us, you aren't blessed with infinite financial resources then you probably put it together and said "well it seems to sound OK" and left the testing of your masterpiece at that. You probably knew that this wasn't the most definitive of tests but put the acquiring of good audio test equipment in the "too hard (expensive)" basket. At the request of our editor I've finally gotten around to doing something to rectify this situation.

The very first and most important piece of test equipment you'll need is an audio oscillator to provide a signal source whose performance is at least an order of magnitude better than the equipment you want to test. Audio oscillators have been around for an awful long time now and people have built very large and successful businesses around them. I've been assured that it really is true that two gentlemen by the names of Bill Hewlett and Dave Packard started building simple one valve Wien bridge audio oscillators in their garage in 1939. Their company is now worth billions of dollars so there has to be a future in it! Perhaps you could duplicate their efforts (if you do please remember where you got the idea!).

In modern hi-fi equipment the most commonly measured and quoted gauge of performance is referred to as the total harmonic distortion of the equipment and is

usually given as a percentage although in the professional literature it is often given in dB. When a signal is passed through equipment such as an amplifier the signal that emerges from the equipment is not an exact replica of the signal that went in. The amplifier tends to change the waveform slightly in the process of amplifying it.

In order to test the equipment it is necessary to apply a signal to the input that is exactly known so that some form of test can be applied to the output to see if it has been corrupted. Normal voice or music signals are very complex and it is impossible to apply any form of quantitative test to them apart from "well it sort of sounds OK". By far the simplest form of signal to handle both mathematically and in test equipment is a sine wave which can be described as

$$V = V_0 \sin(2\pi ft)$$

where f is the frequency of the sine wave. If this signal is applied to the input of an imperfect amplifier (as they all are) what emerges will be the input sine wave multiplied by the gain of the amplifier *plus* other signals as well. These other signals which are generated in the amplifier will have frequencies of $2f$, $3f$, $4f$ and so on. These are called harmonics of the input signal and are caused by distortion in the amplifier itself.

A bloke by the name of Fourier way back when put all this on a mathematical footing which I won't bore you with (assuming I could remember it) but the short of it is that if you have a regular periodic waveform which isn't a sine wave then it can be made

up by the sum of a lot of sine waves with frequencies that are harmonically related. As the signal that emerges from an amplifier when a perfect sine wave is put in is no longer a perfect sine wave, the output can be dissected into the amplified perfect sine wave and the resultant Fourier components which are harmonics of the input signal. Because they are harmonics of the sine wave input the distortion is called harmonic distortion; if all the harmonics are lumped together and measured the result is a total of all the harmonics — hence total harmonic distortion! Now you know what it really means when you see 'thd' on the data sheet.

For more consumer equipment the harmonic distortion is always given as a total but in many applications the level of each individual harmonic is given separately or odd and even harmonics may be separated out. This can help a lot in identifying the mechanisms that are causing the distortion.

The nub of all this is that the signal to be applied to the amplifier must not contain any harmonics of its own or the harmonics from the oscillator can't be separated from those generated in the amplifier and spuriously high (or even low!) readings are obtained. Hence the need for a low distortion oscillator. Most cheapie sine wave oscillators are absolutely useless for testing audio equipment as their distortion is usually around 1% or -40 dB. That is, the total of all the harmonics is one hundredth of a fundamental sine wave. Even the grottiest amplifier can beat this hands down; in fact you'd have to work at it to build one this bad.

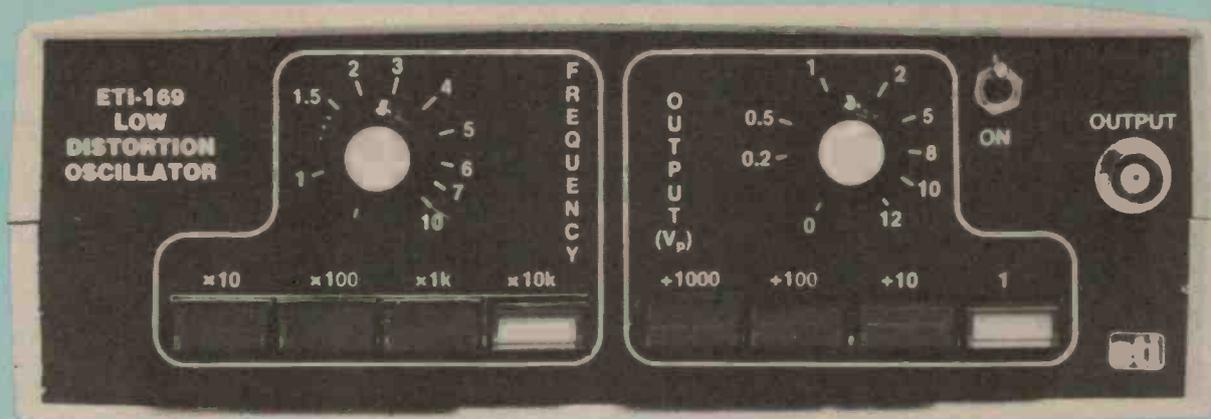

Amplifier distortions normally run from 0.1% or -60 dB (crummy) to 0.001% or -100 dB (so good it's very hard to measure and doesn't really matter!). This latter figure sets the required performance of an oscillator if it's to be used in the testing. That is, the sum of all the harmonics that come out of the oscillator should be about -100 dB or 0.001% of the fundamental. This is a pretty tall order but it seems a good place to start.

There are other factors that must be considered as well as the oscillator. So far I've only discussed the harmonics of the fundamental signal. As well as these any electronic circuit will generate electrical noise. This is a signal that is characterised by having components at all frequencies and sounds like the hiss you get from a tape recorder with a blank tape. Fields will also be picked up from mains operated equipment such as transformers and add in components usually at 50 Hz and 150 Hz. As the usual method to measure this is to use a very narrow selective filter to remove the fundamental and then measure what's left, all these unwanted signals will degrade the measurement of distortion figures.

The range of frequencies to be covered by a useful oscillator is usually set by how much you want to pay for it. The lowest frequency is set by the control circuitry to stabilise the oscillator (more of this later) and for most purposes is set at 10 Hz (you can't hear this low anyway!). The upper frequency is set by the choice of operational amplifiers to be used. To keep costs under control I decided to base all designs around the old trusty NE5534 which sets an upper limit around 100 kHz. The last thing to be decided is the type of output the oscillator should have. The output level is also set by the choice of operational amplifier and limits output swing to ± 12 volts peak.

If an op-amp output is brought directly to the output terminals, this enables people to do very bad things to the output circuitry so it's nicer to have some sort of series resistor in the output. In the industry this is nor-

BALANCING OUTPUTS

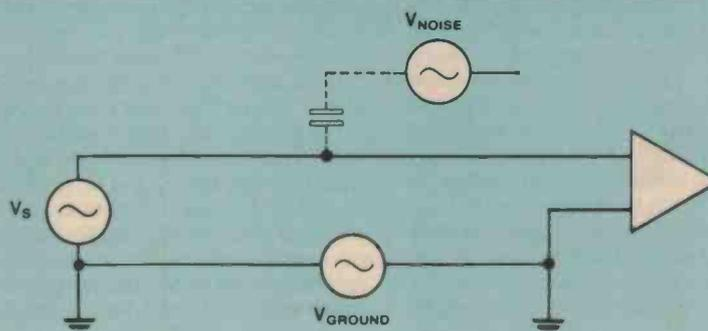

UNBALANCED

In an unbalanced condition the signal seen at the input of the receiving amplifier is degraded

by the addition of any ground loop voltages plus any stray signals that are capacitively coupled into the line.

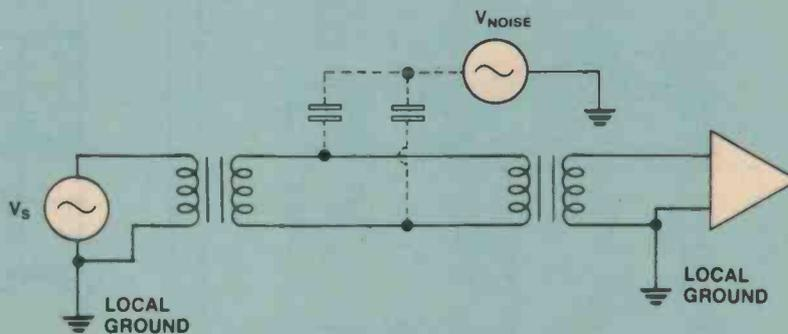

BALANCED

With balance, ground loop voltages have no effect on the input as the input transformer 'floats' the wanted signal on top of any ground

signals and the amplifier is able to ignore them. Capacitively coupled signals tend to be equally coupled into both lines of the balanced pair to be removed by the transformer.

mally chosen as 600 ohms (for a lot of reasons) and ensures that no matter how the output is mistreated (within reason) the oscillator can carry on. Another good reason to set the output impedance at 600 ohms is that then attenuators can be placed after the final amplifier. These will attenuate both the signal and any noise and distortion equally and thus will maintain the distortion performance of the oscillator at very low

levels. This means that if you want to measure the performance of, say, a preamplifier then you can be sure the signal is still clean. To generate these low level signals I decided to include attenuators of 20, 40 and 60 dB or 10x, 100x and 1000x and allowed for a continuous adjustment between.

The last major decision to be made about the output was to decide whether it should be balanced or unbalanced. In a lot of the

older oscillators it was very common to have a transformer in the output. This created what is known as a balanced output which has many advantages. The most important one relates to earthing in an audio system (see box) and makes an awful lot of problems simply go away! For this reason alone all broadcasting and many recording studios use *all* balanced circuits. The big disadvantage is cost. Using today's design techniques means transformers aren't necessary any more but it still doubles the complexity of the output so I decided to settle for an unbalanced output.

Which oscillator circuit?

Oscillator circuits are as many and varied as brands of soap powder and all have their plusses and minuses. The first type that can be ruled out is any form of inductor based oscillator. To build an LC oscillator that worked at 10 Hz you'd need an inductor the size of a brick that'd work just great as an antenna to pick up mains hum. Clearly some form of resistor capacitor oscillator must be used. Probably the most common oscillator configuration used is the Wien bridge (see Figure 1). This design goes way back to before Hewlett-Packard made good use of it and is still used in designs today.

The Wien bridge serves to illustrate what is required for an oscillator to work. Referring to Figure 1 you'll see that the oscillator consists of an op-amp (actually any ampli-

fier will do) with negative feedback around it to control the gain. The elements that form the frequency selective part of the oscillator are the two capacitors and the two variable resistors. If the attenuation from the output to the positive input is calculated then it can be shown that at a frequency equal to $1/2\pi RC$ the two resistors and capacitors divide the voltage at the output by exactly 3 and the voltage at the positive input is exactly in phase with the output voltage. At higher or lower frequencies the attenuation is greater and the two voltages are no longer in phase.

Suppose now that R_x and R_y are adjusted so the attenuation through them is also exactly 3. As they are only resistors the voltage on the negative input will also be exactly in phase with the output and under these conditions the whole network has infinite gain *but only at one frequency*. For frequencies greater or less than $1/2\pi RC$ the positive feedback drops away and the overall network gain becomes finite again.

If an amplifier configuration has infinite gain, it will oscillate as it takes no input signal to produce an output which is exactly what is wanted and what happens. If the attenuation through R_x and R_y is adjusted to be slightly less than $1/3$ then the oscillation will stop; if it is slightly greater than $1/3$ then the amplifier output will be driven hard up against the rails so the average gain over the entire swing is correct for oscillation. The

gain has to be adjusted to be exactly correct for oscillation without clipping.

In Figure 1 the frequency adjusting resistors are conveniently shown as R where two resistors are being changed at the same time to set the frequency. It is assumed that the two resistors are always exactly equal. In the real world this is very hard to do but if you dig into the mathematics a bit you'll find that oscillation can still occur if they aren't equal. All that's necessary is to change the attenuation of the R_x/R_y leg of the bridge. Similarly if the two capacitors aren't equal then once again adjusting R_x and R_y will do the deed.

This is where practicalities start to intrude. If the two variable resistors don't track exactly then when you change frequency R_x or R_y must be adjusted automatically to set up the right conditions for oscillation again. As the amount of adjustment is (more or less) proportional to the mismatch in the variable resistors, a badly tracking dual gang pot will require considerable adjustment of R_y by electronic means and *all electronically variable resistors cause distortion!* (R_y is normally chosen as one end is connected to ground.) This is just one of the rules of the game. In order to build a very low distortion oscillator the two variable pots must track to within a per cent or so. You can buy them but you won't get much change out of \$100. This just isn't a proposition for a cheap oscillator.

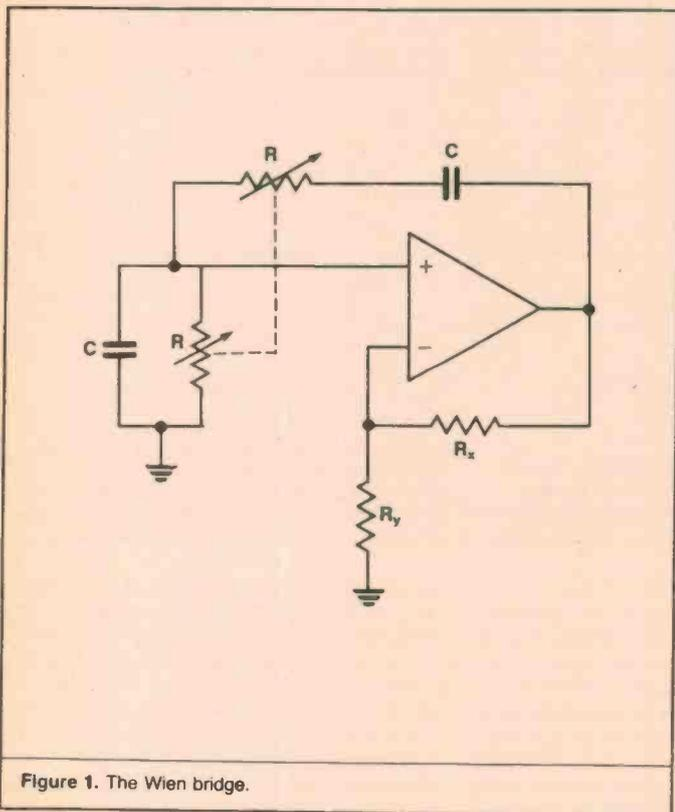

Figure 1. The Wien bridge.

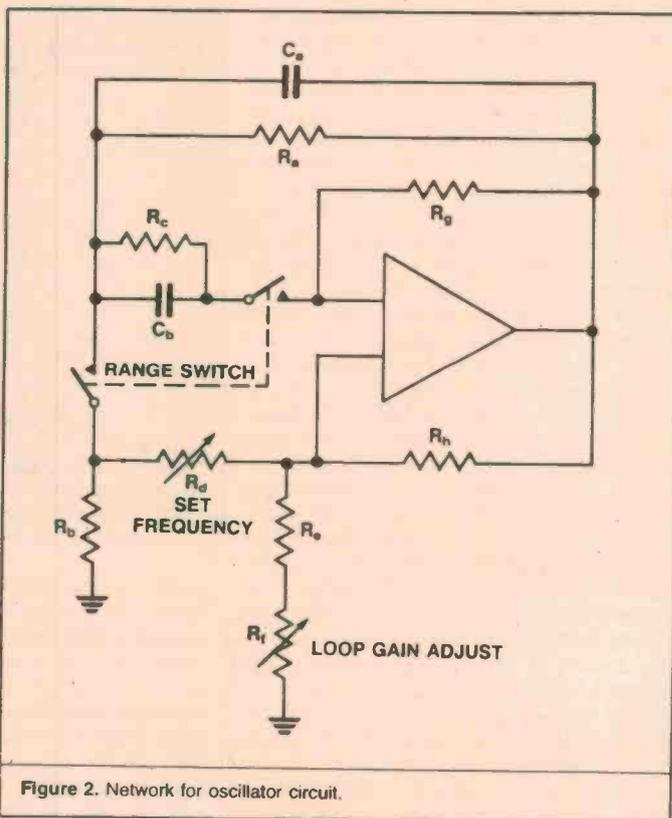
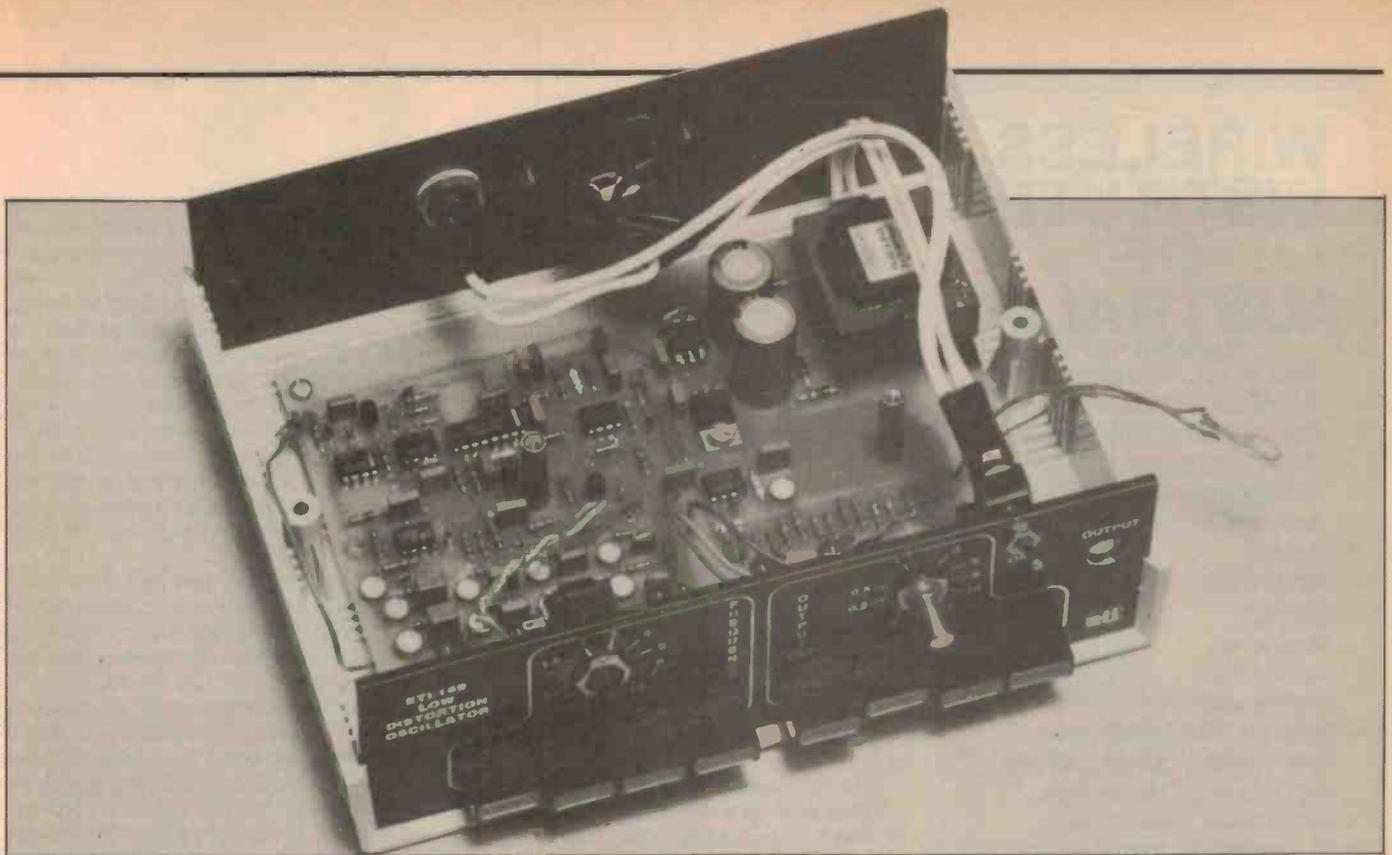

Figure 2. Network for oscillator circuit.



The capacitors also cause a similar problem as it is normal to only use the variable resistors to give a frequency range of 10 to 1 and then switch capacitors to switch ranges. In theory the same capacitors could be used for the entire range but in practice the impedances that would have to be driven at 10 Hz and 100 Hz become silly. Thus in the Wien bridge capacitors with tolerances of 1% are needed. Once again you can get them if you've got the dollars but I wanted this oscillator to be cheap (but, of course, superb!).

A little research into oscillator configurations showed that there has been a fair bit of work done on single control element oscillators. Much of it seems to have been done by Indian gentlemen with much brains but a research budget that wouldn't keep a mouse in cheese. This tends to restrict efforts to tinkering with exotic circuits on paper.

The type of circuit I was after was one where trim pots could be included to adjust out the tolerance variations in all the capacitors and, if possible, a ninth trimmer to adjust for the absolute value of the single gang frequency setting potentiometer (there are eight capacitors for the four frequency ranges). I couldn't find any configuration that was ideal but an article by V. Prem Pyara, S.C. Dutta Roy and S.S. Jamuar gave a method of finding a class of single control element oscillators so I could stir things around for myself.

The network I finally settled on is shown in Figure 2. Obviously it isn't anything like a Wien bridge but all the basic rules still apply. There is a condition that must be preserved in order that the circuit oscillate and if this condition is maintained then a simple

resistance-frequency law can be established. Cranking through pages of mathematics I was able to derive the simple law for the condition for oscillation if $R_b = R_f$:

$$\frac{C_a}{C_b} = \frac{\frac{1}{R_h} - \left(\frac{1}{R_a} + \frac{1}{R_c}\right)}{\frac{1}{R_g} + \frac{1}{R_c}}$$

This may seem all a bit overwhelming but it tells one very important thing. R_d , the frequency control pot, *does not appear in the condition for oscillation* (bewdy!).

More thrashing about with algebra showed that if R_a , R_c and R_g were made adjustable then not only could the oscillation condition above be set up but the frequency of oscillation could be made equal to:

$$(2\pi f)^2 = \frac{2}{R_d R_g C_a C_b}$$

Thus by adjusting R_g it is possible to adjust out any tolerancing errors in the frequency set pot, R_d . Then by adjusting R_a and R_c tolerances in C_a and C_b can be adjusted out.

A quick rats' nest verified that all the mathematics told no lies and quite dramatic control of frequency could be obtained without affecting the oscillation amplitude. According to the numbers the frequency could be taken to infinity if R_d was made equal to 0, and this was very nearly what happened. The only limit was the bandwidth of the operational amplifier and the only problem that remained was the fact that the frequency is proportional to the square root of $1/R_d$. This makes the fre-

quency scale very open for low frequencies and squeezed up at the upper end. However a bit of searching showed that I could get an inverse log law potentiometer from Allen Bradley in Sydney that more or less cancelled the nonlinearity caused by the square root law of the oscillator and gave a frequency-pot rotation law that was usable. This seemed to sort out all the problems with the oscillator itself. The last thing to be dealt with was the control of oscillator level.

In the final oscillator circuit R_h was chosen as the resistor to be varied to set oscillator loop gain. If one had the patience of Job and reflexes that would make a cat look sluggish then one could sit there and fiddle a trim pot to hold the loop gain steady but an automatic loop gain adjust is better. And that is where distortion mechanisms start to appear! R_h need only have about a $\pm 2\%$ adjust but this must be done by a control voltage. About the only voltage variable resistors that can be bought easily in Australia are FETs. If a field effect transistor has zero drain-source voltage applied to it, then it acts as a resistor whose value is varied by the gate bias. However if the applied ac signal becomes too large then it starts to produce distortion as the resistance of the channel is affected by the bias. This can be minimised by applying an ac component to the gate as well and I found that for the small range of resistance control needed it worked just fine.

A far worse problem than this is the possibility of components of the oscillator output voltage getting back to the control gate. The oscillator stabilisation loop consists of an output level detector and a control loop of an amplifier — loop filter to generate a control

WIRELESS INSTITUTE OF AUSTRALIA

FOUNDED 1910

The W.I.A. represents the Radio Amateur at Local, National and International level and offers following services:



- ★ Monthly "AMATEUR RADIO" Magazine, included in membership fee.
- ★ Most REPEATERS have their licence, power and site cost paid by the institute.
- ★ World wide QSL-service.
- ★ Assistance to members in legal problems arising out of the pursuit of their hobby.
- ★ A Weekly Sunday Broadcast to Amateurs and Short Wave Listeners.
- ★ Assistance in dealing with Interference Problems (TVI-RFI etc.)
- ★ Novice and full call courses.
- ★ Trial Novice and AOCB theory exam papers.
- ★ Advice on Radio Mast approvals
- ★ The ONLY representation of the RADIO AMATEUR in legislative matters.



Join the 8,600 Amateur members in the W.I.A. by forwarding this coupon to:
W.I.A. P.O. BOX 300,
CAULFIELD SOUTH, VIC. 3162

Please forward a membership application form and further details to:

Mr, Mrs, Miss, Ms

Address

Callsign

Postcode

voltage for the FET. It is imperative that the output level detector produce as near as possible a dc voltage that is proportional to the ac out of the oscillator. If any ac component is left in the detector output then it will modulate the FET and cause distortion. This dc control voltage must be generated for input frequencies between 10 Hz and 100 kHz which says that any form of rectifying and filtering is out of the question as the detector is part of a control loop.

The way I chose to do it is by using a peak detector which is reset every cycle of the oscillator output (see "How It Works"). This generates a dc voltage equal to the oscillator peak output voltage for a bit more than half the period of the oscillator. When the dc output is stable it is connected to the control integrator and when it is changing the integrator input is switched off. This very nicely removes any ac component from the control output and ensures that the FET only sees dc.

Like any control loop the oscillator control loop must be stabilised and this presents its own set of problems. The loop is stabilised by an extended RC circuit in the integrator that compares the dc from the peak detector with a reference dc set up by a zener diode. This makes sure that the control loop gain and phase are right over the entire 10 Hz to 100 kHz range. All this may seem a little complicated when compared to

some other techniques you may have seen (such as a light bulb in the feedback loop!) but this level control circuit is the essence of producing low distortion signals. The oscillator circuit alone, if left to itself and operated away from clipping, will produce almost no distortion (NE5534s are very good) and in practical circuits almost all the distortion is added in by the stabilisation loop. This stabilisation loop solves that problem almost completely. It is only necessary to adjust the capacitor compensation trimmers so the FET operates in the best region to get distortion performance that was so low I couldn't measure it.

The output circuit and attenuators presented little difficulty as the switch bank I chose to use (you can get it from either Jaycar or Geoff Wood Electronics) has two contact changeovers. This let me use a 'T' type switching configuration to minimise capacitive hopover. The problem is that if the -60 dB attenuator is selected then signal from the higher outputs is capacitively coupled to the output and you don't get -60 dB at 100 kHz (see Figure 3). Using a 'T' configuration shorts out all the capacitive hopover and gives the correct level. ●

Details of the construction, circuit, overlay and parts will be given in the November issue of ETI.

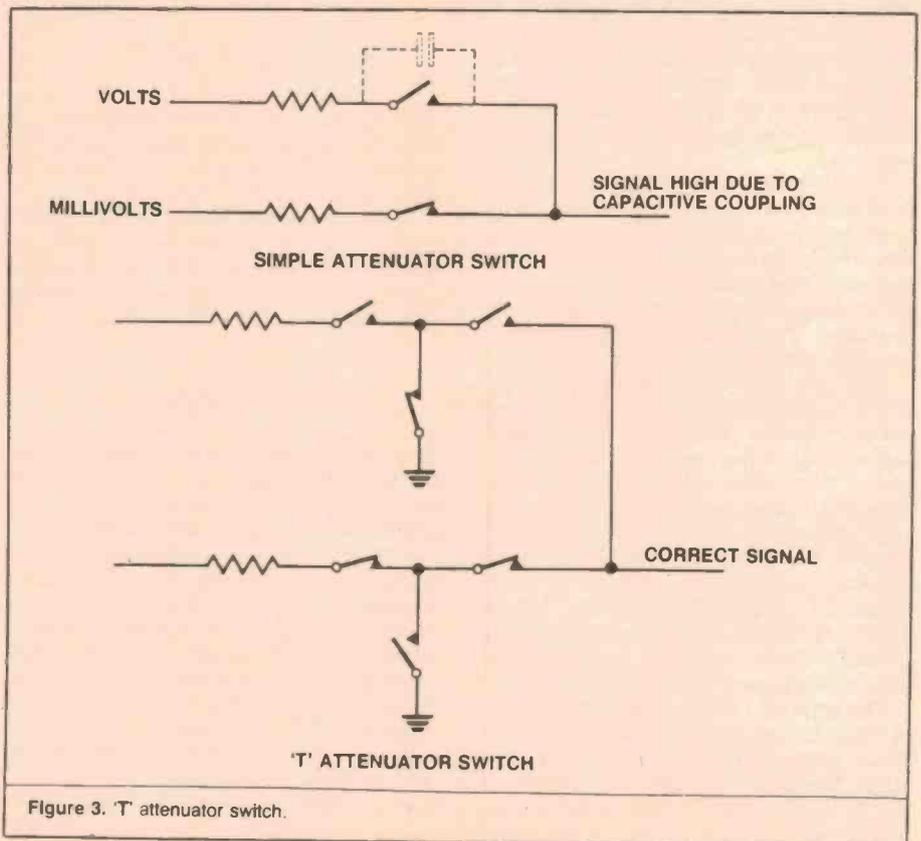

Figure 3. 'T' attenuator switch.

SIEMENS

VARISTORS

**Australia's widest range.
All applications. Biggest stocks.
Lowest prices. Quickest delivery.
What else?**

Siemens is now the biggest and best source of varistors in Australia with a full size range for all applications up to 70 kA. This is of special interest to the telecommunications industry. Comprehensive stocks, plus Siemens position as one of the world's largest manufacturers of varistors underwrites our promise of quick delivery and suitability.

Siemens innovation aims at achieving substantial cost reductions across a wide spectrum in the following applications:

- Power engineering
- Electronic communications
- Power electronics
- Measuring technique
- Processing technique
- Office electronics
- RFI suppression
- Stepped protection

This wide range of varistors is available through Siemens newly strengthened national distributor network. For further information, post the coupon or phone your nearest distributor.

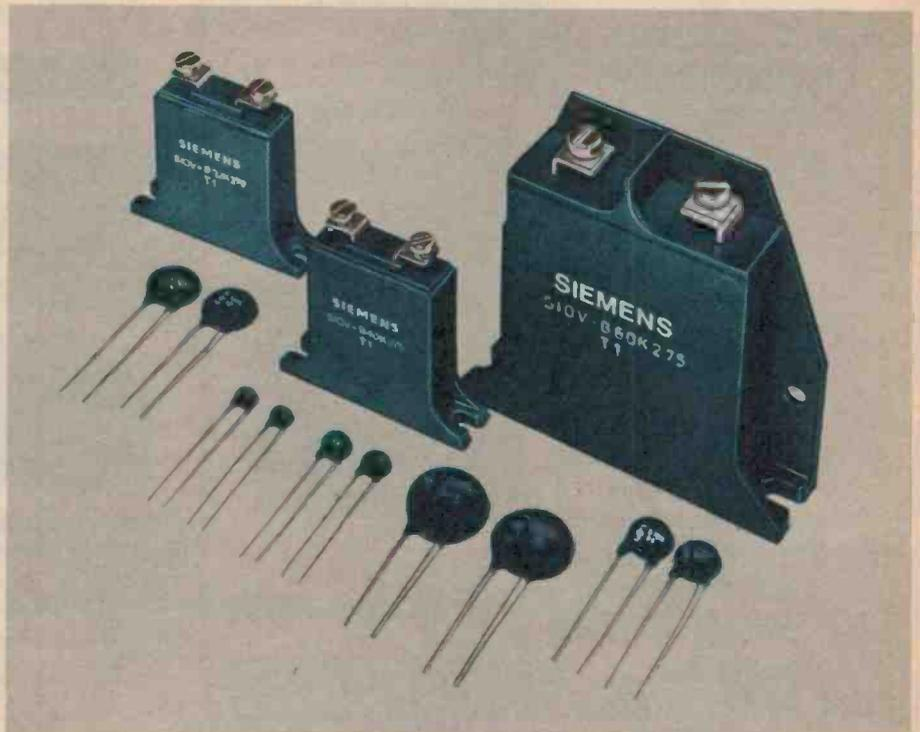

Distributors

Victoria: Promark Electronics (Vic)
(03) 878 1255

New South Wales: Nexus Electronics Pty Ltd
(02) 439 5800

New South Wales: Promark Electronics Pty Ltd
(02) 439 6477

Queensland: ECQ Electronics
(07) 376 5677

South Australia: R.G. Pank Pty Ltd
(08) 51 2411

South Australia: Protronics Pty Ltd
(08) 212 3111

Western Australia: Reserve Electronics
(09) 328 9755

New Zealand: Delphi Industries Ltd
Auckland 563 259

Siemens Ltd.

544 Church St., Richmond, Vic.

Melbourne: 420 7318 Sydney: 436 8730

Brisbane: 369 9666 Perth: 362 0123

Please mail me the new Informative varistors brochure.

NAME

TITLE

COMPANY

ADDRESS

STATE..... POSTCODE.....

Post this coupon now to Siemens Ltd.
Advertising Department, Melbourne.
544 Church St., Richmond 3121.

INGENIOUS ELECTRONIC ENGINEERING

RANGE OF KITS:-

100'S SOLD AM QAM STEREO DECODER KIT

Because this kit has been so popular, we thought we'd give you a chance to buy it at a special price. Cat. KJ-1555

**NORMALLY \$24.95
now only \$17.50
SAVE \$7.45**

**WE WANT EVERYONE TO HAVE
AM STEREO**

**QAM CHIP ONLY
MC13020** Cat. ZK-8862
**Usually \$11.95
NOW ONLY \$6.95
SAVE \$5.00**

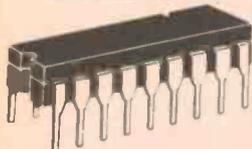

8 CHANNEL MIXER Model 8002

Balanced input 8 channel stereo mixer with features only found in units costing \$1,500 or more!

MAIN FEATURES:

- Balanced (600 ohm) mic. inputs/line inputs
- Input attenuators
- Cannon connectors included in the price
- Bass, mid and treble equalisation on each input
- 'Effects' (i.e. echo etc) capability
- Foldback on all 8 inputs
- Stereo pan on all 8 inputs
- 60mm slide faders used throughout
- 19" rack mount capability (or console mount)
- Professional black front panel with format borders and multicoloured knobs to assist function identification
- Designed for quick and easy service
- VU metering
- Only high quality components used
- 5534A OP amps used for low noise and very low distortion

TECHNICAL:

- Signal to noise microphone input -75dB with ref to +4dBm
- Signal to noise line input -90dB with ref to +4dBm
- Line level +4dBm (0VU)
- Distortion less than 0.005%
- Power requirements 240V AC 50Hz 25 watts

8002 MIXER

Ref. EA April/May 1983

8002 RACK KIT This is the basic mixer. This kit gives you virtually all the electronics. Provided front panel, VU meters, 11 PCB's, all pots (rotary and slide), knobs, components for PCB's, hook-up wire etc. All Cannon XC chassis connectors are included as well. It is ideal for rack mount and all that is necessary is a ±15V 1A power supply. Cat. KJ-6504

\$535.00

FREE DESK CONSOLE THIS MONTH

For October only, if you purchase the above kit, we will give you the desk console FREE - worth \$98
8002 DESK CONSOLE This kit consists of console chassis, power supply including fuses, power lead etc. and wooden end pieces. It enables you to mount the rack kit for conventional desk top use. Cat. KJ-6505

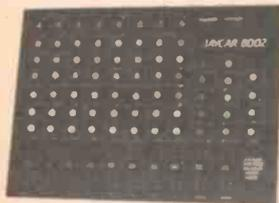

**NOW OPEN:
Our Gore Hill Store
is open till 4 pm
Saturdays**

The Listening Post

Ref. AEM July 1985

This device attaches between audio output of a short wave receiver and the input port of a computer. It allows decoding and printing of Morse Code, Radioteletype (RTTY), AND radio facsimile (FAX) pictures! You can, for example, watch weather maps from the Met and dump them on to your printer! Specific software for the Microbee is in the first article. Programs for other popular computers will be printed in later issues of AEM.

Complete set of specified components (Inc. IDC plug). Cat. KM-3015



ONLY \$29.50

8 SECTOR BURGLAR ALARM

Ref. EA Jan/Feb 1985

Why buy a commercially made up unit for more when you can buy this kit and SAVE money? A unique feature of this kit is the fact that you can wire N/O and N/C alarm sensors ON THE SAME LINE.

- ★ 8 SECTORS
- ★ 2 delayed entry sectors
- ★ Steel box
- ★ Includes battery and siren driver in the price
- ★ Variable exit and entry delays

Cat. KA-1580

\$149.00

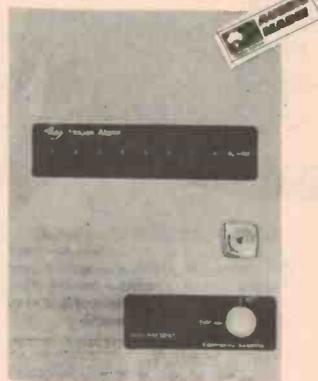

ETI 699 Modem Kit

Ref. ETI May 1985

This brilliant new design is a price breakthrough. Never has a modem with such SOPHISTICATED FEATURES been offered at such an incredibly low price. Now you can have no excuse to gain the tremendous benefits that a modem will offer viz.

- ★ Access to huge data banks
- ★ Networking
- ★ Telecommunications
- ★ Electronic shopping
- ★ Software exchange
- ★ And much more

This ETI kit is a full modem with facilities similar to units costing hundreds of dollars more. It even includes a Telecom approved push button telephone! Now is your chance to use your electronic skills in your new hobby and save a fortune over ready built.

You can obtain this modem kit (which includes a telephone for us humans) for the incredibly low introductory price of only \$139. That's right! \$139, inc. case, down to the last nut and bolt. But hurry! Stocks of the critical modem chip are very low and will severely limit kit supply. Cat. KE-4695

ONLY \$139.00



240V NEGATIVE ION GENERATOR

Ref. AEM Sept 1985

The Jaycar kit includes ABS plastic case, special PCB etc. Please note that this kit is the ORIGINAL KJ-6511 around which the AEM project was based. Cat. KJ-6511

ONLY \$45.00

AEM 9500 Beat Triggered Strobe

Ref. AEM July 1985

This project provides a very bright stroboscopic effect for parties, discos, etc., but with an ADDITIONAL FEATURE! This strobe will actually flash in synchronisation with the music!

The Jaycar kit includes case, photographic reflector, flash tube etc. Cat. KM-3018



ONLY \$59.00

**ONLY \$49.00
SAVE \$10.00**

Electronic Jumper Leads - ETI 341

Ref. ETI August 1985. This project enables you to charge up a car battery via the cigarette lighter plugs in each car. A small inverter boosts the battery voltage from car No.1 to charge the flat battery in car No.2 via its cigarette lighter socket.

It's amazing how quickly you can put enough charge in a flat battery to start the car!

Complete set of parts including 2 x cigarette lighter plugs. Cat. KE-4703

\$39.95



Digital Bench Type Capacitance Meter

Ref. EA August 1985

- ★ Easy to assemble
- ★ 4 digit LED readout
- ★ Measures from 1pF to 99.9uF
- ★ 3 ranges
- ★ Bench type mains powered

Cat. KA-1595

ONLY \$79.95

PLAYMASTER SERIES II MOSFET AMP KIT

Ref. EA Jan/Feb/March 1985

This stereo amplifier that will equal or better just about any integrated commercial amplifier, regardless of price! Leo Simpson, Editor of EA, February 1985

MAIN FEATURES

- Switchable phono input for MM and MC cartridges
- Electronic signal switching
- Full facilities for dubbing between two cassette decks
- Monitor loop for either of two cassette decks or a signal processor
- Click action pushbutton switches for selection of sources, dubbing and tape monitor with LED status indicators
- Centre detents on bass, treble and balance controls
- Multiple detents on volume control
- Heavy duty heatsinks
- Power transformer for low hum and noise
- Easy to build - all parts except power supply mount directly on the two printed circuit boards; wiring has been kept to an absolute minimum
- 100 watts RMS per channel into 8 ohm load
- Less than 0.01% total harmonic distortion

Cat. KA-1500

ONLY \$429.00

AEM 6500 - 60/120 WATT UTILITY MOSFET AMP MODULES

Ref. AEM July 1985

This is a low cost high performance design using proven MOSFET technology. A single pair of (2S)49/2SK134 Mosfets will deliver up to 60 watts output. Another pair may be added for 120 watt performance. The module has been designed to fit into a large variety of commonly stocked instrument cases and rack boxes. It features VERY LOW distortion and impeccable transient performance. It is unconditionally stable and virtually blow-up proof. It can be powered from common transformer/rectifier/capacitor combinations. A Winner! As usual, the Jaycar kit reflects a quality approach. All specified components for each version are included.

60 WATT MODULE Cat. KM-3010
\$49.50
120 WATT MODULE Cat. KM-3012
\$65.00



ETI 698 Microbee Dialler

Ref. ETI July 1985.

Complete set of parts. Cat. KE-4696

ONLY \$19.95

DWELL/TACHOMETER

Ref. EA Sept. 1985

Tune up your car quickly and easily with this handy piece of gear. The Jaycar kit includes case, large meter and Scotchall meterscale. Cat. KA-1612

ONLY \$34.95
**Suits 4-6 or 8 cylinder
cars**



ETI 1401 DIRECT INJECT BOX

Ref. ETI Sept. 1985

This unit accepts unbalanced audio inputs (line or mic. level) and produces a line level balanced signal to drive mixers or balanced input equipment. The Jaycar kit includes die cast box, specified push button switch bank and all other parts. Cat. KE-4708

ONLY \$34.95



**MAIL ORDER HOTLINE
(02) 747 1888**

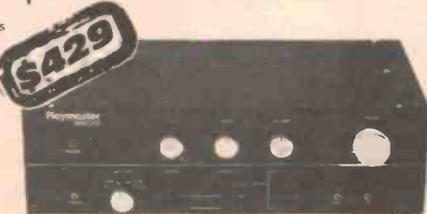

JAYCAR IS No 1...

40 WATT DC INVERTER

Ref. EA August 1985
An upgrade of a previous design featuring a smart new ABS case.
Cat. KA-1598

\$79.95 **NEW!**



300 WATT INVERTER

Ref. EA Sept. 1985
This totally new design is a vast improvement over the EA June 1982 project. It features a modern all-plastic case, easier assembly, toroidal type inverter transformer, auto start up and double, switched power outlets.

And it's cheaper than the old model! The Jaycar kit contains all specified parts to enable you to complete the project in one go.
Cat. KA-1610

ONLY \$199.00



Car Booster Amp

Ref. EA August 1985.
This project enables you to have 2 x 50 watts **ROBUST** power for your car sound system. In order to do this, a special high voltage power supply forms part of the system. Absolutely stunning value for money. Around half the price of inferior commercial units.

The Jaycar kit is, as usual, absolutely complete.
Cat. KA-1600



ONLY \$179

BRAKE LAMP FLASHER

Ref. EA November 1984
What is the best way to avoid rear end collisions when you hit the brakes? According to tests conducted among Sydney Taxi Drivers, the best way is to have additional FLASHING stop lamp installed on the parcel shelf. This project provides this facility. The Jaycar kit includes all specified parts but NOT the automotive stop lamps which are available from motor accessory or hardware stores for about \$20.
Cat. KA-1564

WAS \$16.50
NOW ONLY \$12.50

MAIL ORDER HOTLINE
(02) 747 1888

TOUCH LAMP DIMMER

Ref. EA April 1983
You can turn lights on and off (AND dim them) with one touch! Uses high tech Siemens IC. Features attractive HPM wall plate (supplied). The Jaycar kit contains ALL the necessary components including the small contact spring. Watch out for similar products that don't!
Cat. KA-1508

ONLY \$24.95
REMOTE OPTION Cat. KA-1509
ONLY \$14.50

INFRA RED DIMMER INCLUDES HAND CONTROLLER WITH I.R. DIODES

Ref. EA January 1984
Now you can dim, or turn off the lights from the comfort of your own armchair. This shortform kit contains all parts for the I.R. kit.

NOTE: Kit must be used in conjunction with the Jaycar KA-1508 Touch Lamp Dimmer.
Cat. KA-1529

SUPER SIREN

Ref. EA November 1982
Ear-splitting sound from a CMOS that only draws 5mA on average! Includes a powerful imported piezo siren.

Cat. KA-1055
ONLY \$17.95
SHORT FORM (Electronics Only)
Cat. KA-1484
ONLY \$8.50

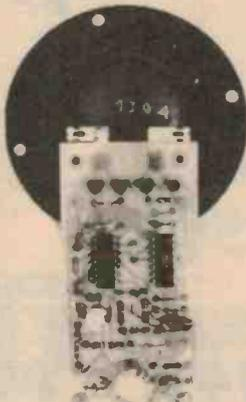

SUBWOOFER AMP

Ref. EA July 1982
State-of-the-art MOSFET technology combined with a low-pass filter. Around 100 watts RMS drive capability. Ideal for use with the Jaycar subwoofer speaker (Cat. CW-2119). Amp will take line level (1V) input or connect direct to speakers. The Jaycar kit includes all PCB parts, heatsink and power supply filter capacitors.
Cat. KA-1452

ONLY \$89.95

ETONE 10" SUBWOOFER

As used in the Electronics Australia subwoofer system.
★ Size 10" (250mm) ★ Cast frame, QT = 0.39, VAS = 631 ★ Power handling 100 watts rms ★ Free air resonance 32Hz ± 1Hz ★ Voice coil diameter 2" ★ Magnet assembly 3kg (6.6lbs)
Cat. CW-2119

ONLY \$99.95

MIDI CONTROLLED SAMPLER

Ref. Sonics July 1985
LAST STOCK - KIT \$1,500
Bulk \$2,000 - BELOW COST

'BEACHCOMBER' DELUXE METAL DETECTOR

Ref. EA December 1984
This unit is sensitive, accurate, has discriminate control and has automatic zeroing, as well as cancelling facility. It comes in a specially imported plastic case facility and pre-wound, sealed search head. The final project looks great and compares favourably with units costing up to \$700.
Cat. KA-1554

THIS MONTH - \$169
SAVE \$70 - usually \$239

300W PLAYMASTER AMPLIFIER

Ref. EA June 1980
This rugged design provides 200W rms into 8 ohms and 300W rms into 4 ohm loads. All parts fit onto a single PCB. It also features comprehensive protection circuitry, and will even withstand short circuits for short durations without adverse affect. Unlike other high powered amps, it is unconditionally stable. It will not therefore break into supersonic oscillations, overheat and fail. The Jaycar kit of this project provides a quality roller-thinned fibreglass PCB and other quality components down to the heatsink compound.
Cat. KA-1115

ONLY \$99.95
300W AMP POWER SUPPLY KIT

This basically consists of a 300VA power transformer (PF4363), rectifier and filter capacitors. It also has 15VAC power for the speaker protector.
Cat. KA-1116

ONLY \$79.95
Speaker Protector for Playmaster 300W amp

Ref. EA July 1980
This device is designed to mate with the Jaycar KA-1115 Playmaster 300W amp module. It also provides the handy facility of switch on mute. This disconnects the speakers for the first few seconds when the amp is switched on, avoiding the horrifying 'thump' in the speakers. If you have expensive speakers (whether you have the EA 300W amp or not) this speaker protector is cheap insurance. The Jaycar kit provides all PCB parts including the relay.
Cat. KA-1117

ONLY \$14.95

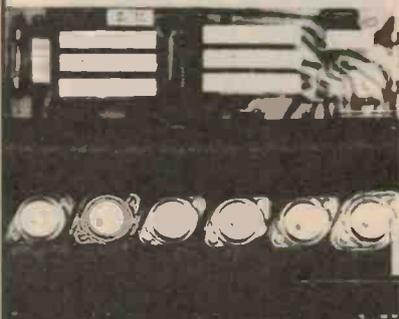

NOW OPEN:
Our Gore Hill Store
is open till 4 pm
Saturdays

Deluxe Red Light Flasher

* This kit is simply the easily identifiable pushbutton square dash mounted switch with a flasher circuit on the back! Very sneaky! You get the deterrence of a flashing red light (the original light switch as used on the real alarms) but without the cost or installation hassle of a full alarm. Kit includes 2 BONUS car alarm window stickers.
Cat. KJ-7000

ONLY \$24.50

EL-CHEAPO RED LIGHT FLASHER

(ETI 260 12V FLASHER)
A 12 volt chrome bezel fits to the dashboard and flashes continuously. Cheap but effective.
Cat. KE-4012

ONLY \$7.95

NOW OPEN:
Our Gore Hill Store
is open till 4 pm
Saturdays

MAIL ORDER HOTLINE
(02) 747 1888

Electronic Crossover

Ref. EA November 1984
NEW SHORT FORM KIT!
You can NOW build this desirable project for a lot less! There have been requests for a version of this kit that can be built into other equipment. This is it! The kit contains PCB and all board components etc. The box (including front panel) and selector switches are not supplied but everything else!
Cat. KA-1571

ONLY \$79.00

Jaycar

ELECTRONICS

Incorporating ELECTRONIC AGENCIES
NUMBER 1 FOR KITS
MAIL ORDER HOTLINE (02) 747 1888

N.S.W. SHOWROOMS

SYDNEY: 117 York Street Tel. (02) 267 1614
CARLINGFORD: Cnr. Carlingford & Pennant Hills Road Tel. (02) 872 4444
CONCORD: 115/117 Parramatta Road Tel. (02) 745 3077
HURSTVILLE: 121 Forest Road Tel. (02) 570 7000
GORE HILLS: 188/192 Pacific Highway (Cnr. Belmore Avenue) Tel. (02) 439 4799

QUEENSLAND MAIL ORDERS:

BURANDA: 144 Logan Road Tel. (07) 393 0777
P.O. Box 185, CONCORD 2137
HEAD OFFICE: 115-117 Parramatta Road, CONCORD 2137
Tel. (02) 747 2022 Telex 72293

SHOP HOURS

Carlingford, Hurstville & Gore Hill
Mon-Fri: 9am - 5:30pm, Thurs 8:30pm, Sat 12pm
Sydney
Mon-Fri: 8:30am - 5:30pm; Thurs 8:30pm; Sat 12pm
Concord
Mon-Fri 9am - 5:30pm Sat 12pm

POST & PACKING

\$5 - \$9.99	\$2.00
\$10 - \$24.99	\$3.75
\$25 - \$49.99	\$4.50
\$50 - \$99.99	\$6.50
\$100 - \$199	\$8.00
Over \$199	\$10.00

COMET ROAD FREIGHT ANYWHERE IN AUSTRALIA ONLY \$13.50



VISA

MAIL ORDER VIA YOUR PHONE



ACTIVE ELECTRONICS

289 LATROBE STREET, MELBOURNE 3000 PH. (03) 602 3499
887 SPRINGVALE ROAD, SPRINGVALE 3171 PH. (03) 547 1046

9am - 5.30pm MON-THURS

9am - 7.30pm FRIDAYS

9am - 12noon SATURDAY

ALL YOU HAVE EVER WANTED IN AN ELECTRONIC STORE - AND MORE!

OCTOBER PRICE SAVERS!

PRICES AVAILABLE FOR MONTH OF ISSUE ONLY

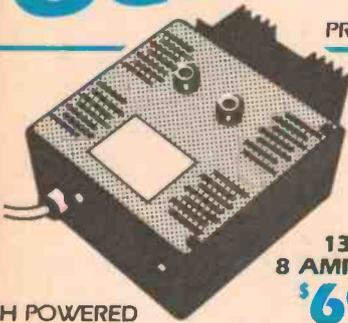

13.8V
8 AMP PEAK
\$69⁰⁰

HIGH POWERED

PANTHER POWER SUPPLY



VERBATIM

SSDD
\$22⁹⁵

BOX OF 10
DSDD
\$29⁹⁵

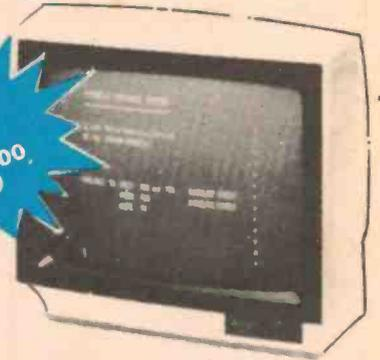

MITSUBISHI MONITOR

COMPARE THESE PRICES!

MEMORY SPECIALS

2732	\$4 ⁹⁵	4164	\$2 ²⁵
2764	\$5 ⁸⁰	41256	\$10 ⁹⁵
27128	\$11 ⁵⁰	6116	\$2 ⁷⁵
4164	\$2 ²⁵	6264	\$15 ⁰⁰
280CPU	\$3 ⁵⁰		

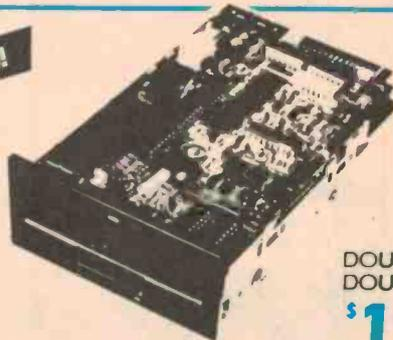

CHINON
5 1/4" DRIVE

SINGLE SIDED
DOUBLE DENSITY
\$149⁰⁰

DOUBLE SIDED
DOUBLE DENSITY
\$195⁰⁰

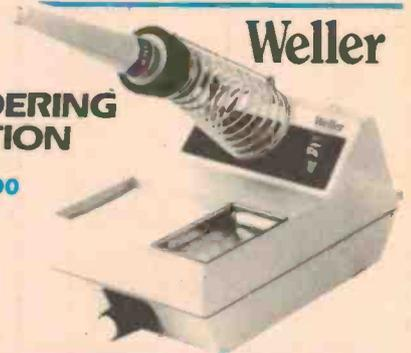

Weller

SOLDERING STATION
WTCPN
\$89⁰⁰



5 WATT
HORN SPEAKER
\$9⁹⁵



120 ML
240 WATTS

INSTRUMENT FAN

\$18⁹⁸

Weller

MARKSMAN
25 WATTS
240 VOLTS
\$24⁵⁰

NEW MAIL ORDER HOTLINE (03) 561 2103

PICK UP YOUR FREE COPY FROM ANY OF OUR ELECTRONIC SUPER STORES

POSTAGE RATES

\$1 - \$9.99	\$2.00	\$50 - \$99.99	\$5.00
\$10 - \$24.99	\$3.00	\$100 - \$199	\$7.50
\$25 - \$49.99	\$4.00	\$200 plus	\$10.00

ALL MAIL ORDERS TO ACTIVE ELECTRONICS NEW BULK STORE 797 SPRINGVALE RD. MULGRAVE. 3170.



PLEASE SEND ME ACTIVE'S FULL RANGE SEMICONDUCTOR CATALOGUE

NAME: _____

ADDRESS: _____

PLEASE ENCLOSE 50c FOR POSTAGE.

COMPUTER ROUTING SWITCH

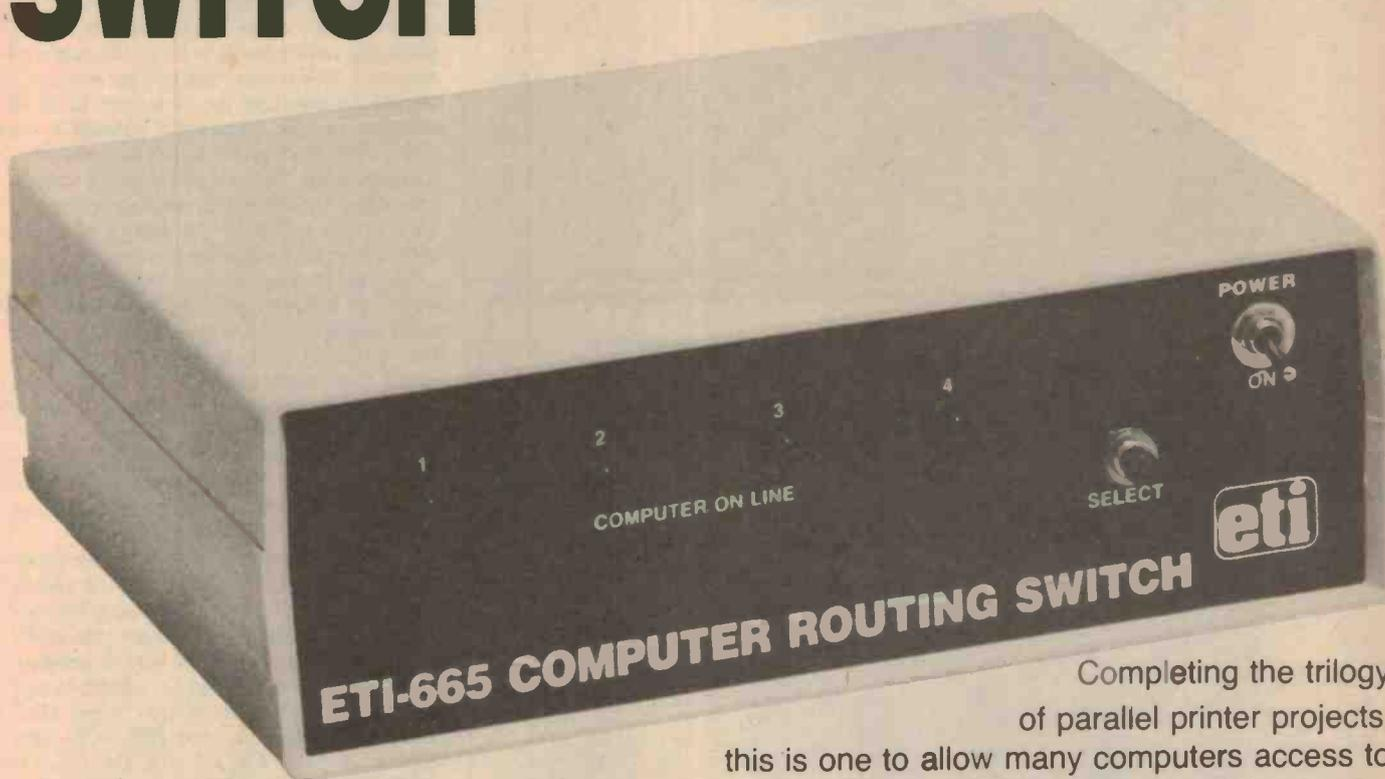

Neale Hancock

Completing the trilogy of parallel printer projects, this is one to allow many computers access to that coveted piece of hardware at the simple push of a button and saves you the hassle of constantly swapping plugs.

IF YOU ARE in a situation where one peripheral is shared by many computers you will probably appreciate the inconvenience of extracting your computer's cable from a bird's nest of others and connecting it to the desired peripheral. One expensive solution is to buy a local area network. Another solution is to use the ETI-665 Computer Routing Switch to give your computer easy access to peripherals. Even if your system expands, the ETI-665 can be expanded to match its growth.

The standard configuration of this project allows four computers access to one peripheral. Since the project has been designed around a central bus, it is easy to expand to allow eight computers to be switched between two peripherals. To add these four additional computers an identical circuit board can be connected to the bus and control lines of the first board.

The project can also be easily expanded to allow the computers to be connected to one of two peripherals. This is possible by using the ETI-666 Parallel Printer Switch to select between them. By virtue of the pin compatibility between the parallel printer switch and the computer routing switch they can be directly linked. There is space inside the computer routing switch's case to accommodate these additional circuit boards.

The switch has been designed to carry twelve Centronics signals, namely SELECT, BUSY, ACKNOWLEDGE.BAR, DATA 0 to 7 and STROBE.BAR. However, the use of this project need not be limited to Centronics signals. Any TTL level signals can be switched by this project, with nine signal lines available for outputs from each computer and three signal lines for inputs.

Construction

Begin the circuit board by soldering in all the pin throughs (this is especially important if the IDC header that you have is a bit wide). Use as little solder as possible to avoid creating bridges between tracks. (This also applies to the ICs.) If you have a fine tip for your soldering iron, it would be a good idea to use it here.

If you only require a four-way computer switch, put in the link which connects pins 3 and 4 of IC9.

The resistors can be soldered in next, followed by the capacitors. When mounting the capacitors be sure to check the polarity of the 10 μ F tantalum capacitor, C1. Next solder in the ICs, all of which must be mounted with the same orientation.

The voltage regulator (IC13) is mounted with the heatsink side facing into the circuit board. Do not forget to solder the IC pins ►

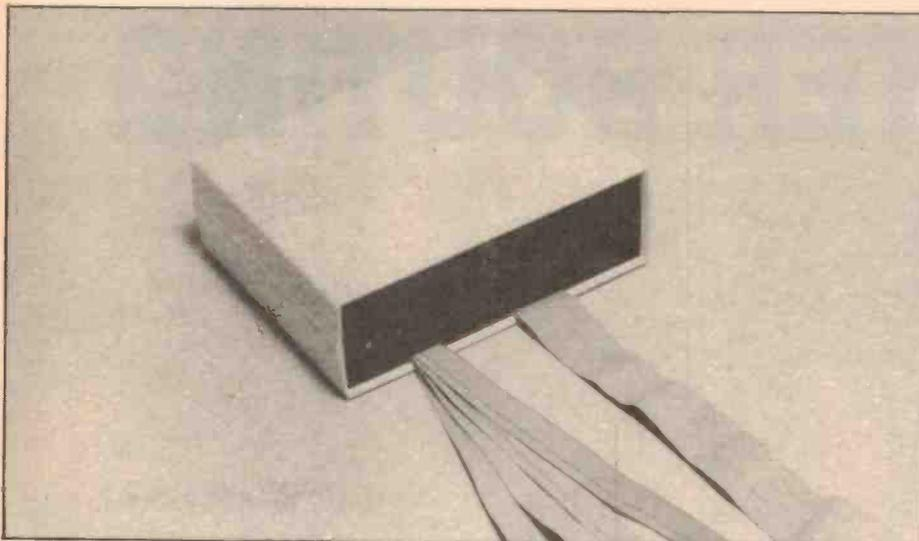

The ribbon cable neatly streams from the back of the routing switch directly to your permanently hooked up computers.

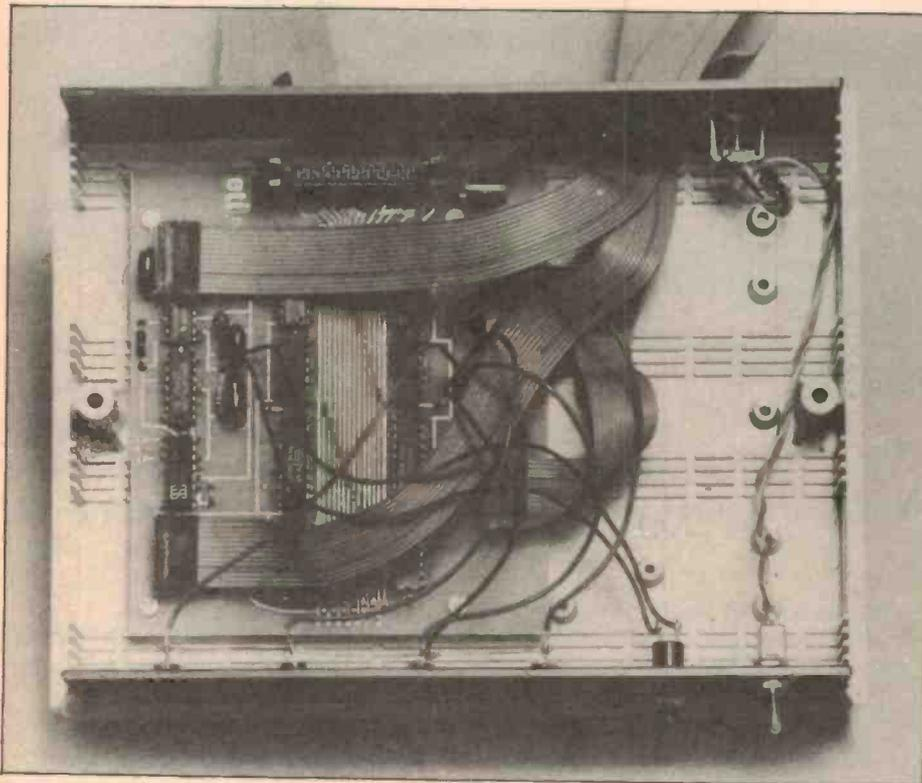

The inside arrangement.

on both sides of the circuit board where pads are provided. The DIL sockets can then go in. If the DIL sockets you are using are notched at the pin 1 end, orient them in the direction of the ICs. Next put in the 26-way IDC header, making sure to face the keyed side into the circuit board.

Finally solder the hookup wire connecting the switches, the plug pack socket and LEDs to the circuit board. When putting in the LEDs, take care to observe the polarity of their leads. The positive leads (the longer

of the two) are connected to the circuit board via their individual hookup wire links. The negative leads are then soldered together and taken to signal ground on the circuit board via a single wire. Check the component overlay for the location of these lead connections on the circuit board.

Any project dealing with many channels of parallel data is bound to become expensive once all the connectors and ports have been accounted for. The ID connectors used in previous printer projects (ETI-666

and ETI-667) were fine in projects where only two lines are switched, but when as many eight lines are being switched, the cost of all those ID headers makes the project fiscally unviable. In an attempt to limit the price as much as possible, I have used DIL IC sockets and headers to connect the computers to the routing switch.

The 14-pin headers which I have selected are crimped onto 14-way cable, then soldered onto the Centronics socket at the other end (see Table 1). (I know it is a 'pain' soldering cables but it is all in the name of economy.) To ensure that you get a connection to ground, link the pins from 19 to 30 together on the Centronics connector, as some Centronics ports do not use pin 19 as signal ground. When installing the cables, remember to orient the header with pin 1 towards the notch in the end of the DIL socket (the same direction as the ICs).

The cable used to connect the routing switch to the printer uses a 26-way IDC socket crimped to the end of 26-way cable. The other end of the cable is connected to a 'male' Centronics plug. In this case it may be more convenient to crimp a Centronics plug onto the cable, since all the connections from the 26-way header are one-to-one. When you are crimping the Centronics plug onto the cable, ensure that the cable is down at the pin 1 end of the plug.

In the design of the board, I have made provision for expanding the routing switch to allow eight computers to be switched between two peripherals. To allow the additional four computers to be added, another ETI-665 circuit board can be added. When this board is constructed the 26-pin IDC header is omitted, as are IC9, IC11 and IC13. Capacitors C1, C2, C3, C4, C5, C6 and resistors R1 and R2 are also left off.

After the relevant components have been soldered on to the printed circuit board, connect the data lines of the two boards together with a short length of 14-way ribbon cable. The cable is soldered to the 14 pads which are located on the end of the printed circuit board near IC1 and IC5. This cable carries all the Centronics signals as well as Vcc and ground to the second circuit board.

So that the control circuitry can select eight computers, remove the link which connects pins 3 and 4 on IC9 and make the wiring connections outlined in Table 2. Some minor surgery must now be performed on the expansion board (board 2). Cut the track which connects pin 5 to pin 12 on IC10, but make sure that you cut it at the pin 12 end. Since IC13 is omitted from the expansion board there is no connection between the voltage rails on both sides of the board. To correct this, solder a pin through where the output pin of the voltage regulator, IC13, would have been (you can't miss it because it is the only one with pads on both sides).

If you require the routing switch to access

two peripherals, you can directly connect the ETI-666 printer switch to it. This can be done via a short length of 26-way ribbon cable with two 26-pin IDC sockets crimped on to it with a pin-for-pin connection. One end plugs on to the input connector of the printer switch and the other plugs on to the 26-pin ID connector in the routing switch. Also connect the Vcc and ground lines of the printer switch to the corresponding lines on the routing switch.

As the drill holes on the circuit board are aligned with the standoffs in the bottom half of the case the circuit board can be mounted directly in it with four 6BA 12 mm bolts. Some thin (5 mm) spacers may be required to give the circuit board more clearance from the bottom of the case. If you are mounting two circuit boards, use 25 mm 6BA bolts with 12 mm spacers between them. There is also ample space in the case to mount the printer switch by securing it in the same manner as the other circuit boards.

The front panel holes should be drilled to suit the size of the LED grommets used, as should the holes for the switches and the rear panel plug pack socket. The rear panel requires slots to be cut into it to allow the ribbon cables to pass through. The cables should be reasonably tight in the slots to allow them some strain relief.

Testing

When checking the circuit board, firstly make sure that all the pin throughs have been soldered on both sides. This also applies to all ICs (except IC12) and component pins (which can be easily missed). Secondly, examine the board carefully for solder splashes, especially in the areas where tracks pass between IC pads. Before you take the plunge and connect up your computers and peripherals, check that the voltage rails are within 200 mV of 5 V. This can be done by measuring the voltage across C6. If this is not the case, double check for shorts around the voltage rails.

If the voltage is correct connect up the computers and peripherals with the ribbon cables. Be sure the pin 1 end of the DIL header is oriented toward the notch in the DIL socket. Select computer 1 and send a test pattern to your printer from it. The test pattern should contain all the commonly used characters on the computer's keyboard. If you do not get a response from the printer, first switch it off line then back on line and send the pattern again. Still no joy? Examine all of the handshake lines ACK, BAR, STROBE.BAR, BUSY and SELECT for shorts (refer to the circuit diagram for the relevant chip pins to check).

If the printer responds with a printout which resembles comic book expletives (*!°%%"%'&'\$#&'%#!!!), there is most likely a short between data lines on the circuit board or in the cables. To track down

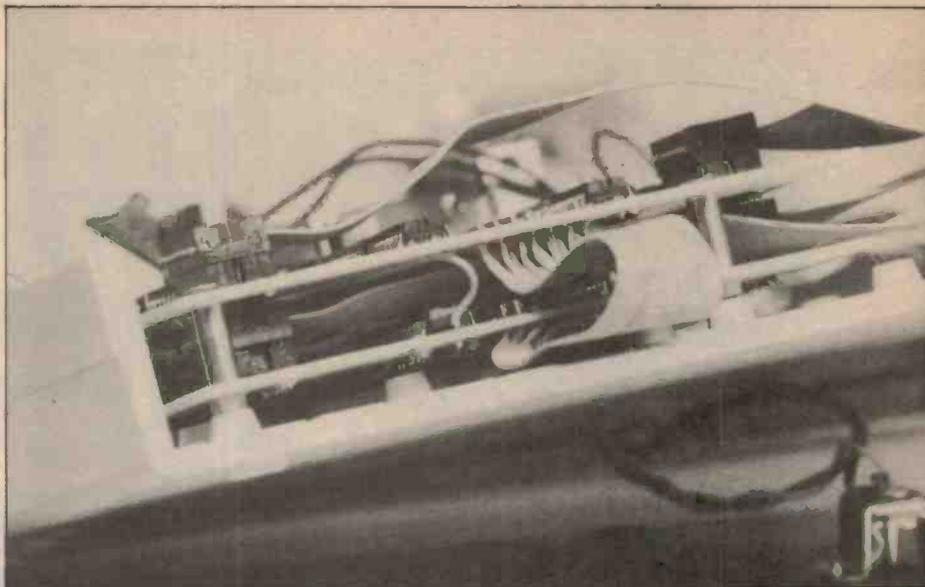

When the routing switch is expanded to cope with eight computers, the additional board sits atop the original board separated by spacers. The ribbon cable jumper goes from the top to the bottom board.

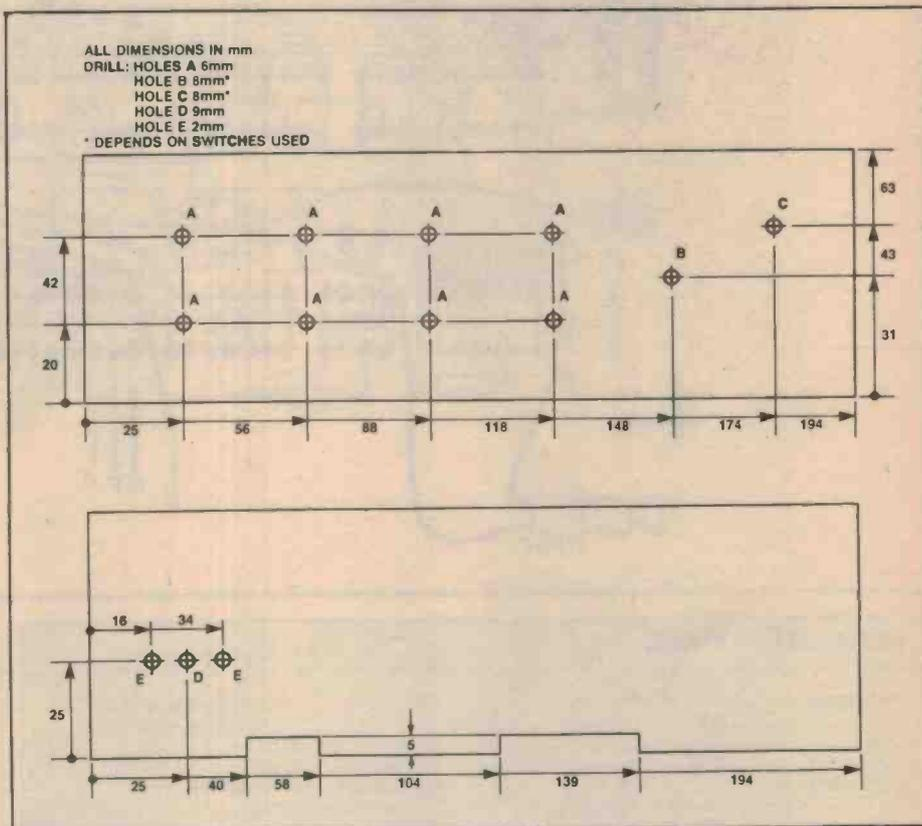

the culprit of this gobbledygook try sending data from a different computer. If the result is the same from all computers, carefully examine the solder joints on the bus lines which run down the middle of the circuit board; a short between these lines would cause this. If you only get a garbled message when a particular computer is selected, check the tracks and the ICs associated with data coming from that computer. To check for a faulty cable try swapping the cable connecting that computer with a cable

which has been used to pass data successfully.

If the pushbutton switch does not select between computers, check for shorts in the vicinity of IC9, IC10 and IC11, as well as the tracks used to carry the control signals to the buffer ICs. If data is being passed on a channel which is not indicated as being selected, check that the hookup wire connecting the LED is soldered into the correct hole on the circuit board; also check the polarity of the LED on the channel.

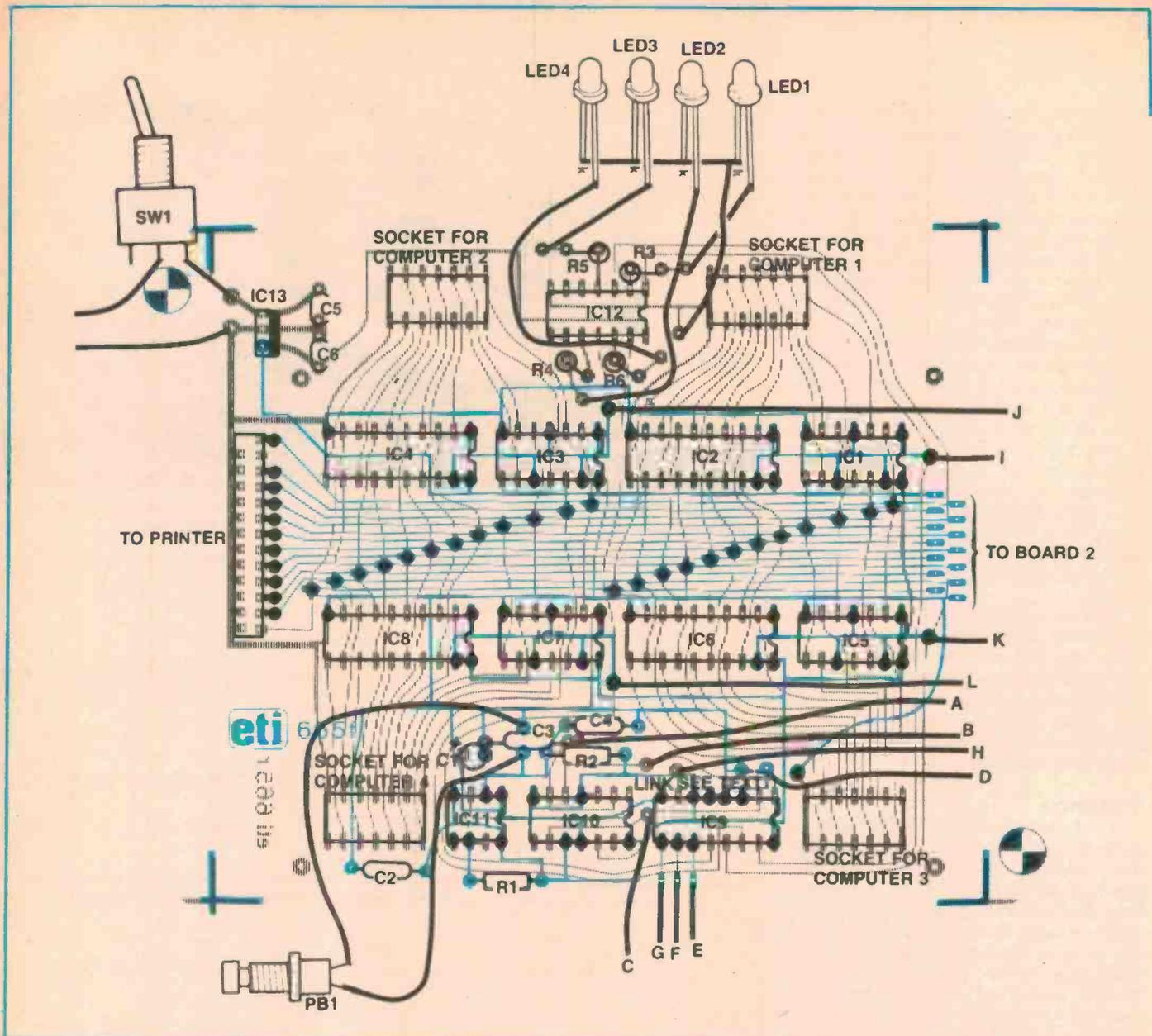

PARTS LIST — ETI-665

Resistors.....all 1/4 W, 5%

- R1.....22k
- R2.....1k
- R3, 4, 5, 6.....100k

Capacitors

- C1.....10μ 16 V tantalum
- C2.....100n greencap
- C3, 4.....10n greencap
- C5, 6.....100n ceramic

Semiconductors

- IC1, 3, 5, 7.....74LS125
- IC2, 4, 6, 8.....74LS244
- IC9.....74LS138
- IC10.....74LS73
- IC11.....74LS555
- IC12.....74LS04
- IC13.....7805
- LED 1, 2, 3, 4.....5 mm red

Miscellaneous

- SW 1.....SPDT miniature toggle switch

PB1.....miniature single pole momentary switch

- 8 x 14-pin IC sockets
- 8 x 14-pin IC headers
- 8 x Centronics solder sockets
- 1 x Centronics ID plug
- 1 x 26-way pin header
- 1 x 26-way ID transition socket

ETI-665 pc board; plastic instrument case non-vented 200 x 160 x 70 mm; Scotchcal label; 4 x 5 mm LED bezels; 9 volt plug pack and socket to suit; 26-way ribbon cable; 14-way ribbon cable; hookup wire, link wire, solder, nuts, bolts, etc.

PRICE ESTIMATE:

- 4-way switch \$88
- 8-way switch \$133

Prices with Centronics sockets \$144 and \$245 respectively.

TABLE 1. CABLE CONNECTIONS

DIL plug pin no	Centronics pin no	Function
1	13	SELECT
2	10	ACK
3	8	D6
4	6	D4
5	4	D2
6	2	D0
7	19-30	SIGNAL GND
8	19-30	SIGNAL GND
9	1	STROBE
10	3	D1
11	5	D3
12	7	D5
13	9	D7
14	11	BUSY

For a guide to components and kits for projects, see SHOPAROUND this issue.

computer routing switch

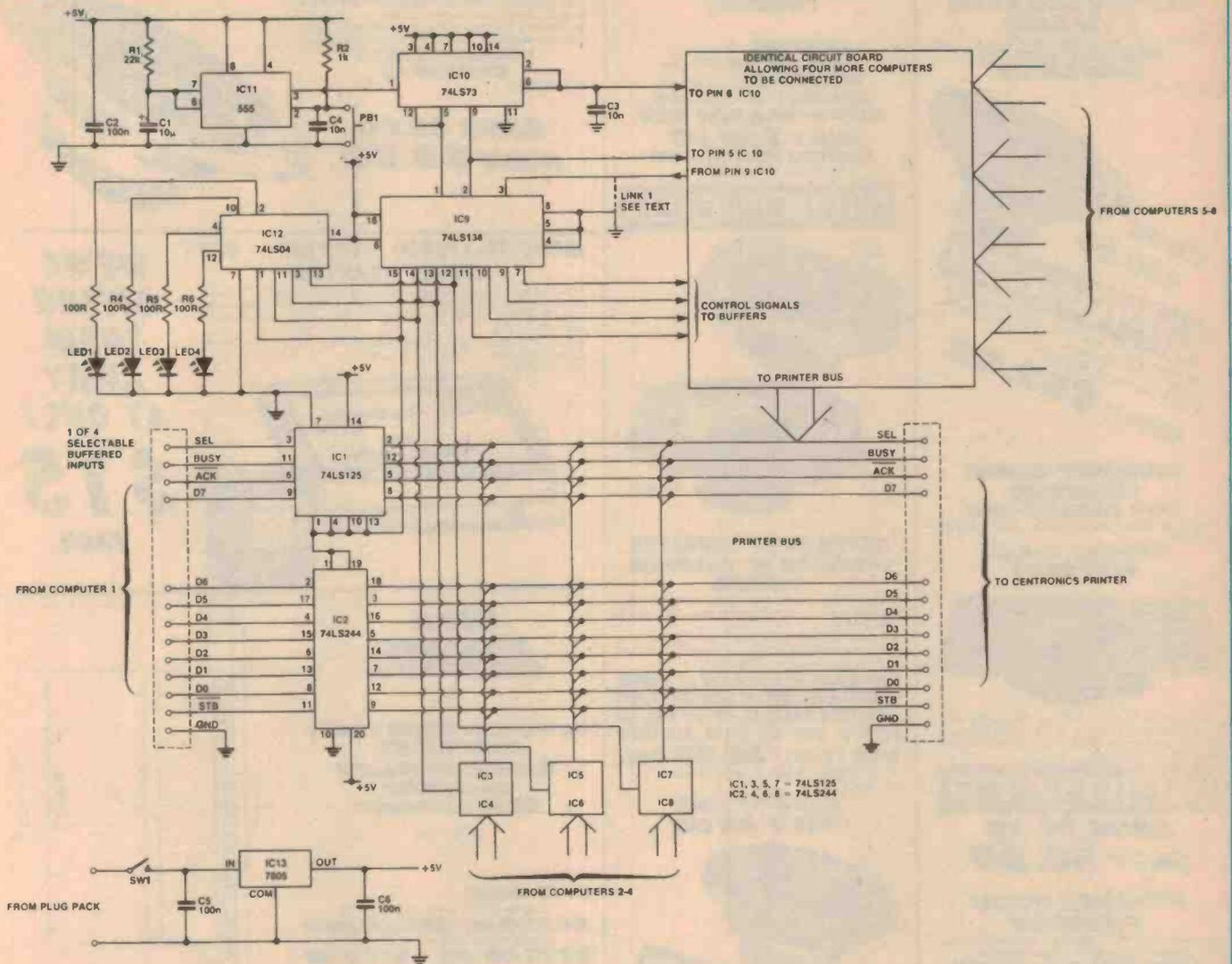

HOW IT WORKS — ETI-665

The circuit uses tristate buffers to switch 12 Centronics signals from one of four (or eight) selected computers to a central bus. This bus carries nine signals from the computer to the peripheral (D0 to D7 and STB.BAR) and three signals from the peripheral to the computer (SLCT, BUSY and ACK.BAR).

When computer 1 is selected, the tristate outputs of IC1 and IC2 are activated and the outputs of the other tristate buffers IC3 to IC8 go into the high impedance state. To select which buffer is to be enabled, a pushbutton switch is used to trigger IC11. The output from IC11 is then used to increment a counter. This counter consists of JK flip flops (IC10) configured as an asynchronous, two stage counter (a three stage counter is used for selecting eight computers).

The output from this counter drives a 1 of 8 demultiplexer, IC9. The circulating '0' output from this IC is used to select the buffer which

TABLE 2. EXPANSION INTERCONNECTS

Board 1 hole no	Signal	Board 2 hole no	Signal
A	CEAR OUT	A	CLEAR IN
C	Q2 OUT	B	CLOCK IN
D	Q3 IN	C	Q3 OUT
E	CHANNEL 5 ENABLE OUT	I	CHANNEL 5 ENABLE IN
F	CHANNEL 6 ENABLE OUT	J	CHANNEL 6 ENABLE IN
G	CHANNEL 7 ENABLE OUT	K	CHANNEL 7 ENABLE IN
H	CHANNEL 8 ENABLE OUT	L	CHANNEL 8 ENABLE IN

is to be switched onto the bus. The link connecting pin 3 to ground allows IC9 to operate as a 1 of 4 demultiplexer and is only omitted if you need to select eight computers.

The combination R1 and C1 is used to protect the timer chip, IC11, against 'push' contact bounce, whereas the combination of R2 and C4 protects IC11 against 'release' contact bounce. Capacitors C2, C5 and C6 serve to protect it against mains spikes which may

cause the counter to inadvertently increment, with undesirable consequences for anyone using the printer at that time. Since the selected output from the 1 to 8 demultiplexer is a '0', this must be inverted so it can drive an LED to indicate the selected computer. This is performed by the hex inverter chip IC12.

IC13 regulates the dc input voltage from the plug pack to provide the 5 V supply required for the circuit.

HI FI SPEAKERS at

PIONEER 12" GUITAR SPEAKER 65W RMS

Strictly limited quantity. Crazy price. They won't last.
USUALLY \$59.50
SAVE \$20.00

Cat. CG-2381



SAVE \$20.00

PIONEER
 ★ Impedance 8 ohms ★ Power rating 65W RMS ★ Sensitivity 97dB/w 1/2 metre ★ Frequency range 80-6kHz ★ Resonance frequency 80Hz

ONLY \$39.50

PIONEER DOME TWEETER LESS THAN 1/2 PRICE

A dome tweeter for under \$10! Ridiculous! Only 250 available.

USUALLY \$18.50
SAVE \$9.55

Cat. CT-2020



★ Impedance 8 ohms ★ Power rating 25W RMS - 100W RMS system power ★ Crossover frequency 2000Hz ★ Sensitivity 95dB/w 1/2 metre ★ Frequency range 2000 - 20,000Hz

PIONEER

SAVE \$9.55
ONLY \$8.95

PIONEER HORN TWEETER

Great sounding black anodised square metal horn. Two together sound great. Limited quantity.

LESS THAN 1/2 PRICE
WAS \$13.50 SAVE \$7.00

Cat. CT-2114

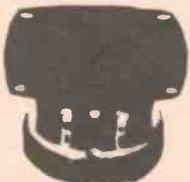

PIONEER

★ Impedance 8 ohms ★ Power rating 12W RMS - system 60W RMS ★ Crossover frequency 2000Hz ★ Sensitivity 101 dB/w 1/2 metre ★ Frequency response 2000 - 20,000Hz

SAVE \$7.00
ONLY \$6.50

MANUFACTURERS/WHOLESALEERS!!

Turn your surplus stock into cash!!

Jaycar will purchase your surplus stock of components electronic equipment or traded-in gear in good condition. We are continually on the lookout for sources of prime quality merchandise that can be resold to electronic enthusiasts.

Call Gary Johnston or Bruce Routley NOW (02) 747 2022

GREY MIDRANGE & TWEETER

TWEETER Cat. CT-2040
USUALLY \$5.95 ea
MIDRANGE Cat. CM-2042
USUALLY \$12.50 ea
BUY 2 OF EACH FOR ONLY \$23.90
SAVING YOU \$13.00
 More than the two tweeters!

PIONEER

Tweeter



Midrange

NEVER TO BE REPEATED PIONEER 6" WOOFER 4 OHMS

Another huge scoop once only purchase. Ideal woofer for cars, or a small speaker box, or even two in a tower box.

★ Power Rating 15 watts RMS ★ Nominal Resonant Frequency 40-45Hz ★ Nominal Sensitivity 97dB/W ★ Response Range fo - 4,000Hz

WE STOCK THIS IN A TWIN CONE VERSION FOR \$17.50
A REALLY SPECIAL PRICE WOULD BE \$10. BUT WE HAVE SLASHED THEM TO ONLY \$6.00 ea.
 THAT'S CRAZY. Limited Quantity.

Cat. CW-2105

SAVE \$11.50
ONLY \$6 ea



IMPORTERS DISTRESS STOCK 6" PIONEER WIDERANGE

4 ohm impedance. As used in ETI projects.
USUALLY \$6.95
SAVE UP TO \$4.45

Cat. AS-3011

ONLY \$2.95
10 up \$2.50 each

MAIL ORDER HOTLINE (02) 747 1888

MIDI CONTROLLED SAMPLER - Ref. Sonics July 1985
LAST STOCK - KIT \$1,500
Built \$2,000 - BELOW COST

5" MIDRANGE

This large magnet cone midrange really delivers the sounds. Sealed back, cloth surround.

★ Impedance 8 ohms ★ Frequency response 1kHz-12kHz ★ Sensitivity 96dB ★ Power 60WRMS system.

USUALLY \$12.50
SAVE \$3.00

Cat. CM-2062

SAVE \$3.00
ONLY \$9.50

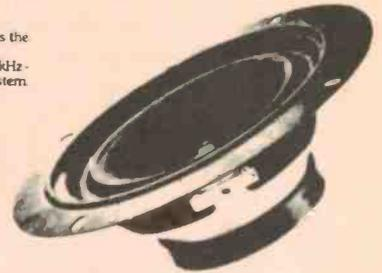

MONO-TO-STEREO ADAPTOR - VCR STEREO ADAPTOR

This unit will take a mono line input and convert it to 2 x "Pseudo" stereo outputs. You can use it to create a stereo effect from mono sources such as TV, AM radio, VCR's etc. (It is not a stereo decoder for AM radio or TV). Inputs and outputs RCA sockets. Dimensions 110 x 130 x 32mm. Comes complete with 240V plug pack.

Cat. AV-6506



WE'RE GIVING THEM AWAY AT ONLY \$15 EACH

VIFA SPEAKER SENSATION

European Style 2-way Speaker Kit
Sensational NEW design by Dave Tillbrook

SEE AEM JULY

SPEAKERS:

Tweeter DZ5TG 8 ohm Cat. CT-2020
\$45.00 ea - \$90.00 pair
 Woofer PZ1WO 8 ohm Cat. CW-2132
\$122.00 ea - \$244.00 pair

Crossover Network (Kit) Cat. CX-2630
\$39.95 ea - \$79.90 pair
Total \$413.90

for stereo SPECIAL INTRODUCTORY OFFER

The low value of the Australian dollar may mean that the prices of these components will go up. As a goodwill gesture, we will sell the speaker/crossover set (for stereo) for only

\$399.00!!!

We estimate that you will be able to build the cabinets for around \$50 - \$90 (depending on finish). This means that you can end up with a superior 100 watt speaker system for under \$500!!!

UNBELIEVABLE! Technical Data - Woofer

Nominal Impedance	8 ohms
Frequency Range	26 - 4000Hz
Free Air Resonance	33Hz
Operating Power	2.5W
Sensitivity (1W @ 1m)	92dB
Nominal Power	60 watts
Voice Coil Diameter	40mm
Voice Coil Height	12mm
Air Gap Height	6mm
Voice Coil Resistance	5.8 ohms
Effective Diaphragm Area	222cm ²
Moving Mass	20 grams
Thiele/Small Parameters	
Cm	2.4
Ce	0.41
Qr	0.35
Vas	80 l
Weight	1.65kg

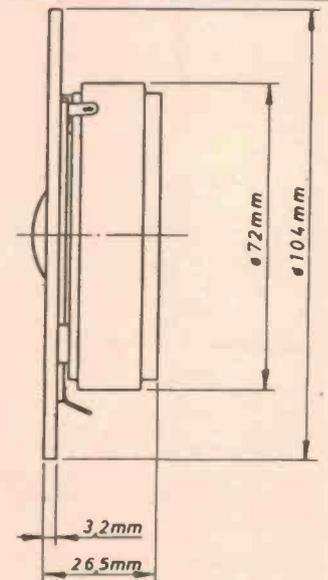

NOW AVAILABLE

This offer has been extended for October, as they were not available in August.

NOW OPEN: Our Gore Hill Store is open till 4 pm Saturdays

Technical Data - Tweeter

Nominal Impedance	6 ohms
Frequency Range	2 - 24kHz
Free Air Resonance	1500Hz
Operating Power	3.2 watts
Sensitivity (1W @ 1m)	90dB
Nominal Power	90 watts
Voice Coil Diameter	25mm
Voice Coil Height	1.6mm
Air Gap Height	2.0mm
Voice Coil Resistance	4.7 ohms
Effective Diaphragm Area	7cm ²
Moving Mass	0.3 grams
Weight	0.53kg

GREAT PRICES...

PLESSEY POT PACK BARGAINS BACK!

BRAND NEW STOCK

You get over 50 assorted pots (mostly English made by Plessey) in a pack weighing just under 1/2 a kilo. All have plain shafts, most with a flat, some are log, some are linear and some are switched. This pack is a great bargain at under 12¢ a pot how could you go wrong? The price of pots has recently risen and even if you only use 3 out of the 50 you could be in front. Cat. RP-3900

ONLY \$5.95

MIDI CONTROLLED SAMPLER - Ref. Sonics July 1985
LAST STOCK - Kit \$1,500
Built \$2,000 - BELOW COST

RESISTOR NETWORKS
 50 assorted values, top quality, 10 lead resistor networks. This pack would normally be worth \$40. Values range from 680 Ohms to 1M Ohm. Cat. RR-3380

ONLY \$10.00
 That's 20¢ per network!

22 PIN IC INSERTER
USUALLY \$6.50
October only \$2.50

CMOS safe conductive plastic - exclusive bent pin alignment guides in handle - ground strap can be connected - one hand operation



NO FRILLS KEYLESS CAR ALARM GIVE AWAY

No frills burglar alarm complete with siren.

- FEATURES:**
- Easy to install
 - No key lock switch required
 - Alarm sounds whenever the boot or bonnet is opened, or stereo/radio is removed
 - Highly sensitive to any attempt to enter the car
 - Low current drain
 - Solid state, professionally designed product
- Many people want car alarms with all the gadgets included, like ultrasonics and glass break detectors. If you've been thinking of a car alarm for your second car, then now is the time to buy it.

Cat. LA-5315
USUALLY \$49.95
this month \$27.50
SAVE \$22.45

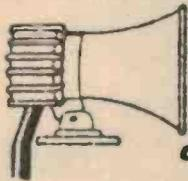

NOW OPEN:
Our Gore Hill Store
is open till 4 pm
Saturdays

MAIL ORDER HOTLINE
(02) 747 1888

EXPERIMENTERS RF MODULATOR

We have a quantity of Video Modulators to clear. We call them experimenters because we cannot offer a warranty, but at the price who would expect one. Complete in its own metal box and with 3 metres of 75 ohm coax with plug attached. (That alone is worth \$2.00)

Cat. LT-3805

LIMIT 5 PER CUSTOMER
ONLY \$2 each

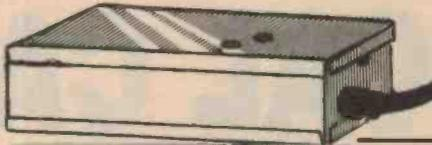

SURPLUS STOCK

Contact Gary Johnston or
 Bruce Routley

ONLY 90 AVAILABLE EXPERIMENTERS CLOCK with Fluorescent display

This clock was actually designed to go with a clock radio. It has a transistor output which could switch on a radio etc. Its 240V operated with mains lead and step-down transformer, which has a spare winding at about 9 volts. A second PCB houses 5 touchtype pad switches to control alarm time set - fast and slow, time set - fast and slow, and a snooze control, as well as an LDR to automatically dim the display at night. Display measures 90mm x 25mm with digits actually being 15mm high. It also displays AM or PM. Supplied with circuit diagram. Cat. XC-0150

ONLY \$9.95

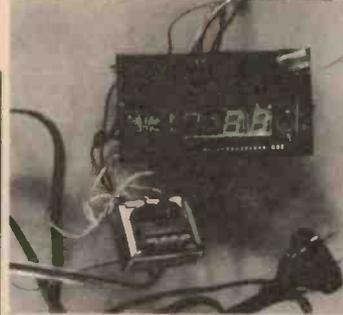

WHAT ARE MICROCHARTS?

MICROCHARTS are professional, comprehensive, plastic summary cards packed with key time-saving information on: microprocessors, electronics, programming, and tools for business. Colourful 100% plastic MICROCHARTS are carefully organised for fast use at home, work, and in the classroom.

7400 PINOUTS

Cat. BM-8503

Z80 CPU

Cat. BM-8500

WORDSTAR

Cat. BM-8506

6502 (65XX)

Cat. BM-8502

8086 & 8088

Cat. BM-8508

'C' LANGUAGE

Cat. BM-8512

BASIC INTRO

Cat. BM-8510

ALGORITHMS

Cat. BM-8504

8080 & 8085

Cat. BM-8501

HOW TO SAMPLE

Cat. BM-8514

ALL ONE PRICE
\$11.95 each

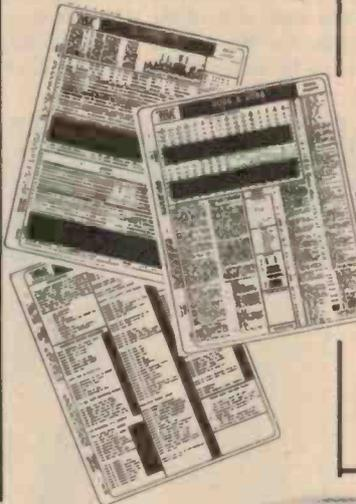

COMPACT disc DIGITAL AUDIO COMPACT disc DIGITAL AUDIO COMPACT disc DIGITAL AUDIO COMPACT disc DIGITAL AUDIO

JAYCAR COMPACT DISC BUYERS CLUB

Compact Disc players have become very popular but there is emerging a serious problem. The problem is, availability of compact discs!

Only about half the record stores carry compact discs and those who do generally have a limited range. Apart from this, most stores have risen in price from \$22 to \$25 recently, so they are getting very expensive!

Jaycar has decided to do something about it! Now you can order your favourite compact disc albums by Mail Order! You simply pick up the phone and quote your credit card number or send us a letter with your cheque or money order.

FREE PHONE SERVICE: If you do not know whether your favourite artist/album is on compact disc ring us! We have extensive files on all importers range and we will be able to advise you instantly!

SPECIAL CATALOGUE SERVICE: To save time we can send you a 56+ page catalogue of all CD titles currently available in Australia. (There are around 2,900 titles currently available, but some are in very short supply). Cost of the catalogue \$4 inc. P&P or FREE with any CD order over \$100. We recommend that you get the catalogue. It has separate sections for Jazz, Classical and Popular music and is a MUST for the serious CD enthusiast. (It is updated 4 times a year).

EXCLUSIVE! 30 day satisfaction guarantee! The CD enthusiasts at Jaycar have found that some albums on CD have been disappointing. This was either because the actual material was not as good as expected, or the quality of the CD itself has shown up poor mastering or excessive tape noise etc. This can be an expensive mistake!

BUT NOT if you buy your Compact Discs from Jaycar! If you buy a compact disc from us and you find that the disc is not to your liking you can **RETURN** the disc to us for a 50% credit towards future disc purchases. YES, you **DO** lose 50% but if the disc is worthless to you that's better than nothing! The offer is conditional on the returned disc being in **ABSOLUTELY FLAWLESS** condition and within 30 days of purchase. Once a disc is accepted back it will be kept by Jaycar. (You cannot return them to record companies for credit). We will accumulate stocks of returned discs and publish regular bulletins of these titles which will be sent to you automatically. Prices will be below normal retail.

For more information write to P.O. Box 185, Concord 2137 or ring our Mail Order Hotline (02) 747 1888.

YOU CAN ORDER NOW!

COMPACT disc DIGITAL AUDIO COMPACT disc DIGITAL AUDIO COMPACT disc DIGITAL AUDIO COMPACT disc DIGITAL AUDIO

VK POWERMATE

Ref. EA December 1983

This kit enables you to build a power supply that will give 13.8 volts at up to 10 amps! (8 amps continuous). Ideal for running mobile transceivers from home. Kit is complete with box and front panel. Cat. KA-1120

Usually \$99.95
October ONLY
\$69.95
SAVE \$30.00

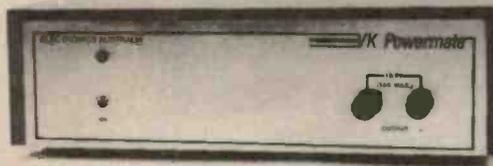

Jaycar ELECTRONICS

Incorporating ELECTRONIC AGENCIES
NUMBER 1 FOR KITS

MAIL ORDER HOTLINE (02) 747 1888

N.S.W. SHOWROOMS
 SYDNEY, 117 York Street Tel. (02) 267 1614
 CARLINGFORD, Cnr. Carlingford & Pennant Hills Road Tel. (02) 872 4444
 CONCORD, 115/117 Parramatta Road Tel. (02) 745 3077
 HURSTVILLE, 121 Forest Road Tel. (02) 570 7000
 GORE HILL, 188/192 Pacific Highway (Cnr Bellevue Avenue) Tel. (02) 439 4799

QUEENSLAND MAIL ORDERS: BURANDA, 144 Logan Road Tel. (07) 393 0777
HEAD OFFICE: P.O. Box 185, CONCORD 2137
 115-117 Parramatta Road, CONCORD 2137
 Tel. (02) 747 2022 Telex: 722993

SHOP HOURS
 Carlingford, Hurstville & Gore Hill
 Mon-Fri: 9am - 5:30pm; Thurs 8:30pm; Sat 12pm
 Sydney
 Mon-Fri 8:30am - 5:30pm; Thurs 8:30pm; Sat 12pm
 Concord
 Mon-Fri 9am - 5:30pm; Sat 12pm

POST & PACKING
 \$5 - \$9.99 \$2.00
 \$10 - \$24.99 \$3.75
 \$25 - \$49.99 \$4.50
 \$50 - \$99.99 \$6.50
 \$100 - \$199 \$8.00
 Over \$199 \$10.00

COMET ROAD FREIGHT ANYWHERE IN AUSTRALIA ONLY \$13.50



VISA



MAIL ORDER VIA YOUR PHONE

OPTICAL CAR ALARM SWITCH

Part 2

This forms Part 2 of our sophisticated car alarm update project. It describes the switch receiver and installation into your vehicle, after which you should have instant alarm deactivation at your will

S. K. Hui

IF BUILDING THE first part of this project (the transmitter) was a nightmare you can be assured that no more fiddly work is required in Part 2, (the receiver).

One of the biggest challenges in this project has been minimising the area of the pc board. To achieve this, good layout design is essential but not sufficient. The biggest obstacle is the wasted space that has to be reserved for the IC pads whether there are tracks going to the pads or not. Once a chip

is soldered on, the entire area under the chip on the other side of the board is occupied by the pads. Consequently, no components can use that area.

However, imagine that the pins of the ICs do not (as they usually do), go through a hole on the board to be soldered on the other side, but have their pins cut short and soldered onto pads on the same side of the board, and the area under the ICs on the other side of the board can be occupied by

another IC soldered on in a similar manner. Effectively, the board area is doubled.

There has been a lot of talk recently on the use of surface mounting techniques on pc board assembly lines. The biggest gain in using such technique is faster board assembling. In industrial applications, a robot arm can be used to put the components down on to the board effeciently and accurately. For most hobbyists, this technique suffers a fatal draw back, which is that surface mount

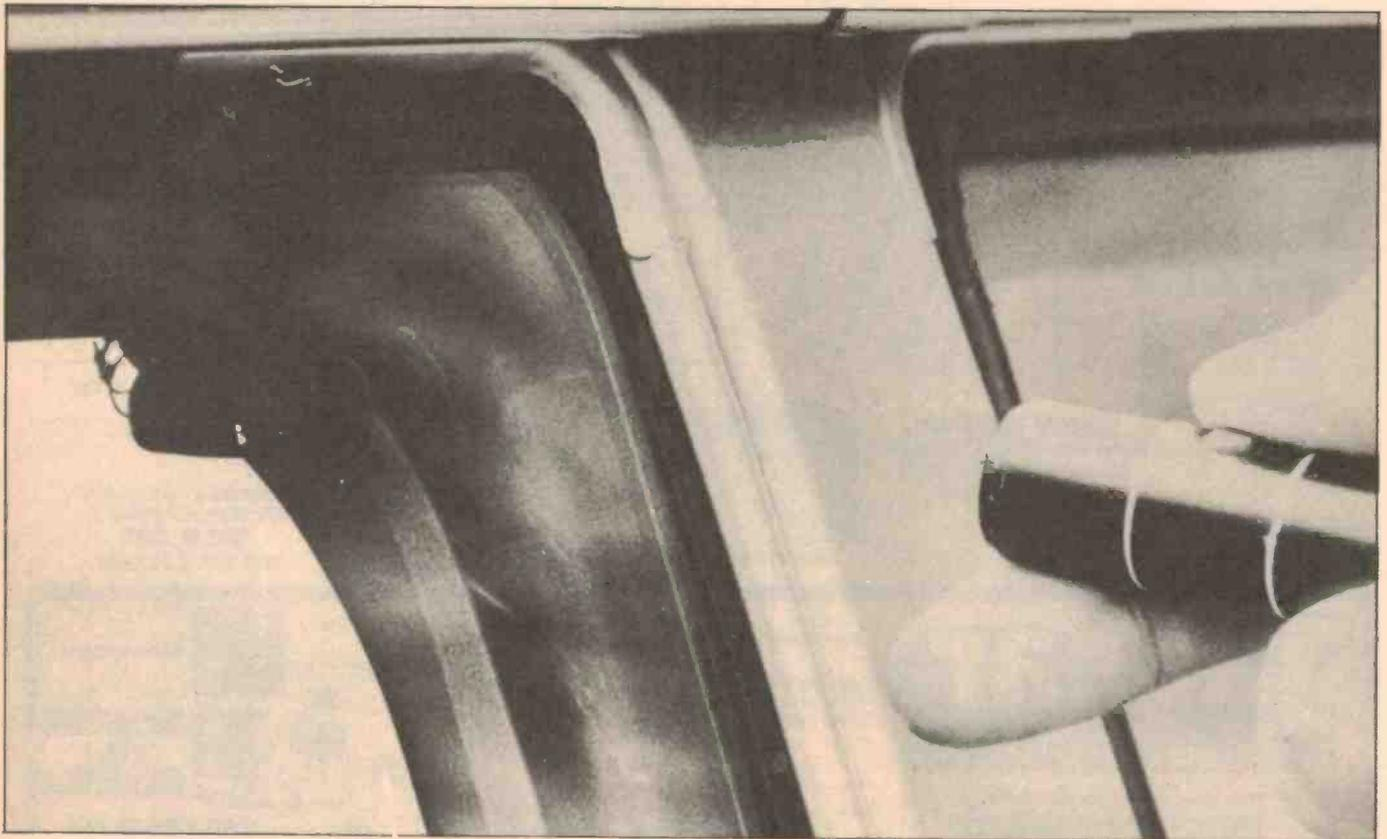



Above. The sensing diode on the right should insert into the heatsink tube to form the fixture on the right. Left. A display of the semi-surface mount and surface mount components.

TABLE 2. ALTERNATIVE TRANSMISSION RATES

Transmission rate	R8	R9	RV1
2519 bit/s	1.5k	6.8k	10k
1412 bit/s	6.8k	10k	20k
7073 bit/s	47k	6.8k	20k

components are far too expensive.

During the design of the transmitter board I was inspired to use the technique of 'semi-surface mounting' with normal components. As the name implies, it is not true surface mounting, however, it has the advantage of using normal, low cost components. The resulting board is very small relative to the number of chips. The tracks are not too thin for ordinary board etching techniques and only a small number of holes need to be drilled.

One small problem is that some of the pins need to be chopped before they are soldered on. Quite often, pins are used as feedthrough wires for joining tracks together so extra care is required when assembling the board.

The design approach of the receiver circuit is pretty standard. It works like the 6850 ACIA mentioned in Part 1, which depends on a local oscillator with its frequency divided down to generate the sampling pulses. The frequency of the oscillator is programmed by a resistor/capacitor network built around a Schmitt trigger. The three optional transmission rates (detailed in Part 1) require three different matching frequencies in the oscillator. Resistances for these frequencies are tabulated in Table 2. For those of you who devised your own transmission rate, instructions and formulae are given to help you to tune your oscillator.

Resistances, capacitances and characteristics of ICs are very much dependent on temperature. This means your well tuned oscillator can quite easily drift out of the workable range. This is important because the temperature inside a car can vary a lot depending on the weather. To ensure reliability, high stability resistors and capacitors are recommended. I have tested the re-

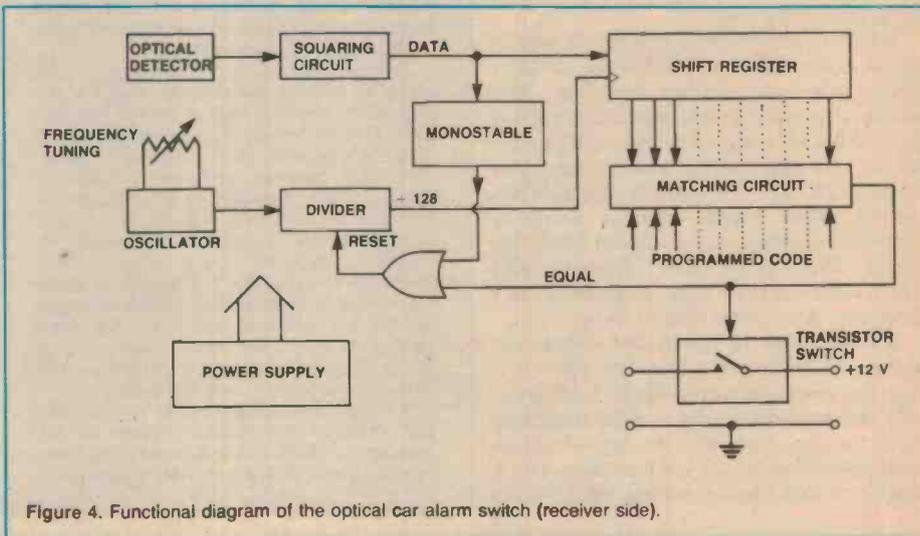

Figure 4. Functional diagram of the optical car alarm switch (receiver side).

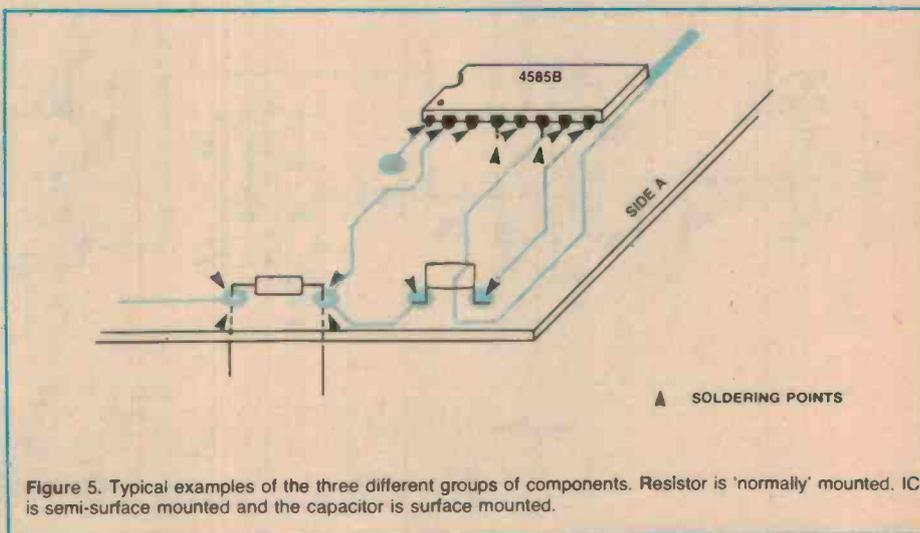

Figure 5. Typical examples of the three different groups of components. Resistor is 'normally' mounted. IC is semi-surface mounted and the capacitor is surface mounted.

ceiver board under extreme temperatures. It worked at 0°C and would probably work below that, however, it stopped working at about 91°C. This was with low quality components so it would be a surprise if a circuit with better components could not better these figures.

Design principle

The first thing to look at in the design is the detector (Figure 4). It senses the light falling upon it and amplifies it. The signal is then squared up to true logic levels (1 and 0) by the squaring circuit which is basically a comparator. The output from this section

Project 343

should be the same as the original wave form when it was first transmitted.

Major design of the circuit is centered on sampling and matching of the code. A tunable high frequency generated by the oscillator is divided by 128. The divided frequency is the same as the sampling frequency. It clocks the shift register and the sampled data from the detector gets passed down the register chain. The 16-bit register, consisting of two 4094 ICs, has an output for each stage which feeds the matching circuit, consisting of four comparator ICs. These comparators continuously match the shift register outputs with the other set of logic signals programmed by you.

When a perfect match occurs, an 'equal' signal is sent back to disable the divider, which stops any further sampling. The whole circuit stays in this condition until it is reset. This same signal is also used to turn off the transistor switch, which in turn, disconnects the 12 V to your car alarm. Without its power supply, the car alarm is disabled, allowing access without false triggering. Most alarms have a flashing LED which indicates their state. If yours doesn't have one, it's a good idea to fit one.

It's necessary to install the optical car alarm switch in such a way that when you start the engine, power to the ETI-343 is cut off. This minimises a lot of false triggering since the car alarm and the optical switch are both off while you are travelling. (As a matter of fact, during testing the ETI-343

HOW IT WORKS — ETI-343

The reverse leakage current through the light sensing diode D1 depends on the amount of light falling on it and the ambient temperature. To minimise the current generated due to the latter factor, its terminals are held to the same potential, i.e. short circuited. Since pin 2 and pin 3 of IC1 are both at virtual ground, the voltage generated at the output of IC1 is equal to the product of the leakage current and the 2.2 megohm resistor. Capacitor C1 forms a negative feedback path for high frequencies, thus eliminating any high frequency oscillation in the op-amp. The output signal is then ac coupled to the second stage, a comparator. Any sensor will drift due to age or ambient changes, so dc coupling is obviously not a good solution.

The reference voltage of the comparator is set by R4 and R5. Normally, its output is sitting at 0 V. The first start bit causes the output to go high and, due to the inverting action of IC12a, a negative edge is applied to pin 11 of IC3. This generates an active low pulse to IC11a (pin 13). Normally the 'equal' signal is low (see the schematic pin 12, IC11a), because there isn't a matching code received. Therefore, pin 11 of IC11a goes low and releases the reset pin of IC4. IC4 starts to count the number of clock pulses applied to its pin 10 from the oscillator. For every 128 clock pulses, an active high pulse is generated at pin 13. This is our data sampling pulse. This pulse clocks the data into the registers.

IC5 and IC6 are cascaded into a 16-bit wide shift register. The parallel outputs of the register go into IC7, IC8, IC9 and IC10. They continuously match the register outputs with

your programmed code. The 'equal' signal ripples through the four stages matching circuit if the codes are all matched. It goes high and feeds back to pin 12 of IC11a. The OR operation of IC11a allows the active signal to reset IC4 regardless of the state of the monostable (IC3). This disables clocking of the shift register and turns off transistor Q1. Capacitor C8 charges up and turns off Q2, cutting off the 12 V supply to your car alarm. Turning on your ignition key now also cuts off the supply to the ETI-343 circuit.

The oscillation frequency of IC12b is controlled by the total resistance of RV1, R9, R10 and C7. The formula is given by:

$$f = \frac{1}{RC \ln \left(\frac{(V_{CC} - V_{T-})}{(V_{CC} - V_{T+})} \frac{V_{T+}}{V_{T-}} \right)}$$

where C (C7) is capacitor value in μF , R the value of R9, R10, RV1 in kohms, f the frequency in kHz, V_{T+} , V_{T-} the threshold voltages and V_{CC} is the operating voltage (9.3 V). Threshold voltages are different for different manufacturers and are affected by operating voltage and temperature. R is the total resistance of RV1, R8 and R9. For any transmission rate that you are using, the golden rule is: the frequency of oscillation must be equal to $128 \times 2 \times$ your chosen transmission rate. Table 2 shows the recommended values for R10, R9 and RV1 for the three transmission rates I introduced in Part 1. The above formula will help if your transmission rate does not fall into any of these.

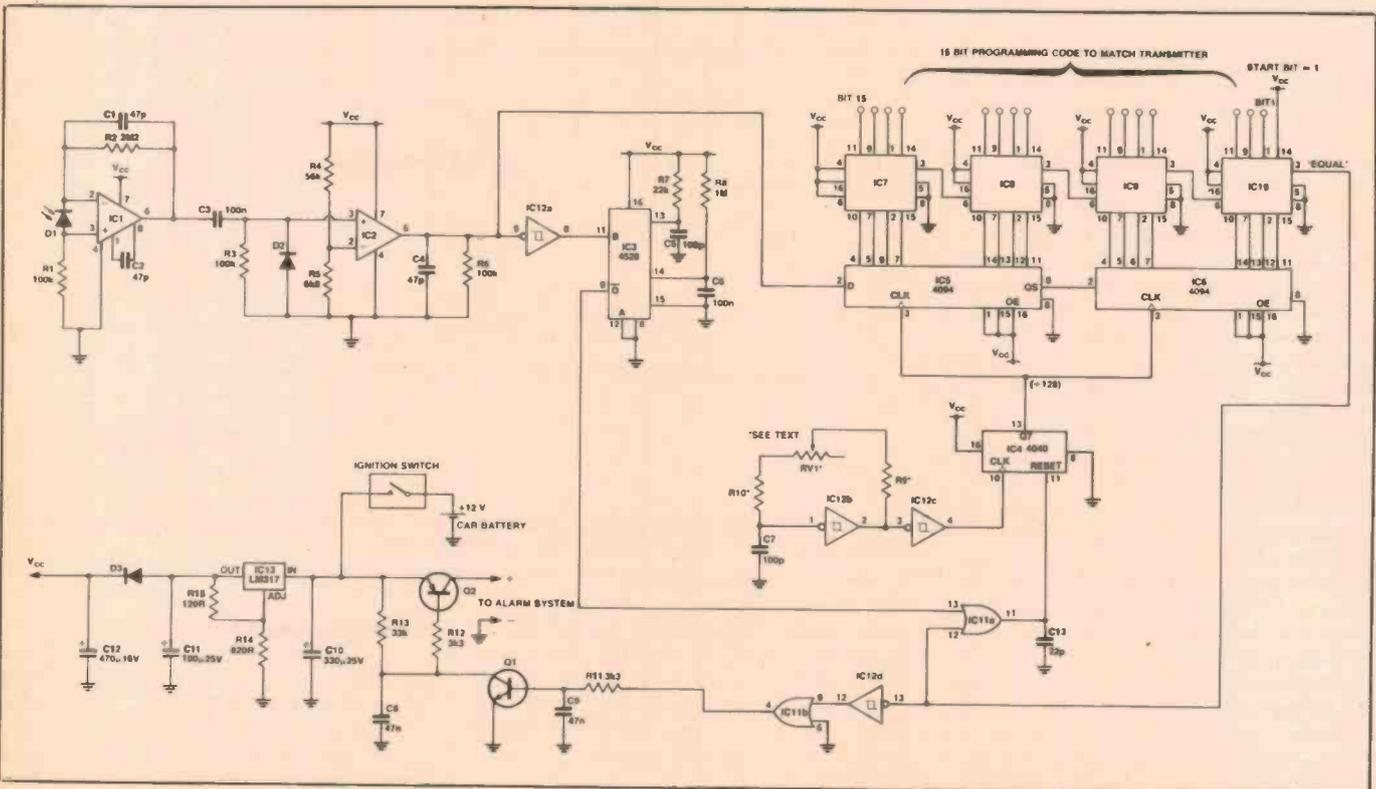

PARTS LIST — ETI-343

Resistors.....all metal film, 1/4 W, 1% unless noted
 R1, 3, 6.....100k
 R2.....2M2, carbon film
 R4.....56k
 R5.....6k8
 R7.....22k
 R8.....1M
 R9, 10, RV1.....(see values in Table 1)
 R11, 12.....3k3
 R13.....33k
 R14.....820R
 R15.....120R

Capacitors (all resin dipped mono-ceramic unless noted)
 C1, 2, 4.....47p
 C3, 6, 14, 15, 16, 17, 18, 19.....100n
 C5, 7.....100p
 C8, 9.....47n
 C10.....330µ, 25 V, electro
 C11.....100µ, 25 V, electro
 C12.....470µ, 16 V, electro

Semiconductors
 IC1, 2.....CA3130E
 IC3.....4528B
 IC4.....4040B
 IC5, 6.....4094B
 IC7, 8, 9, IC10.....4585B

IC11.....4071B
 IC12.....40106(SGS)
 IC13.....LM317 (TO220)
 Q1.....BC549C
 Q2.....BD140
 D1.....BPW21
 D2.....1N914
 D3.....1N4001

Miscellaneous

A double-sided pc board; mica, screws and nuts for IC13 insulated mounting; hookup wire; thermal heatshrink 10 mm diam, 30 mm long.

Price estimate: \$68

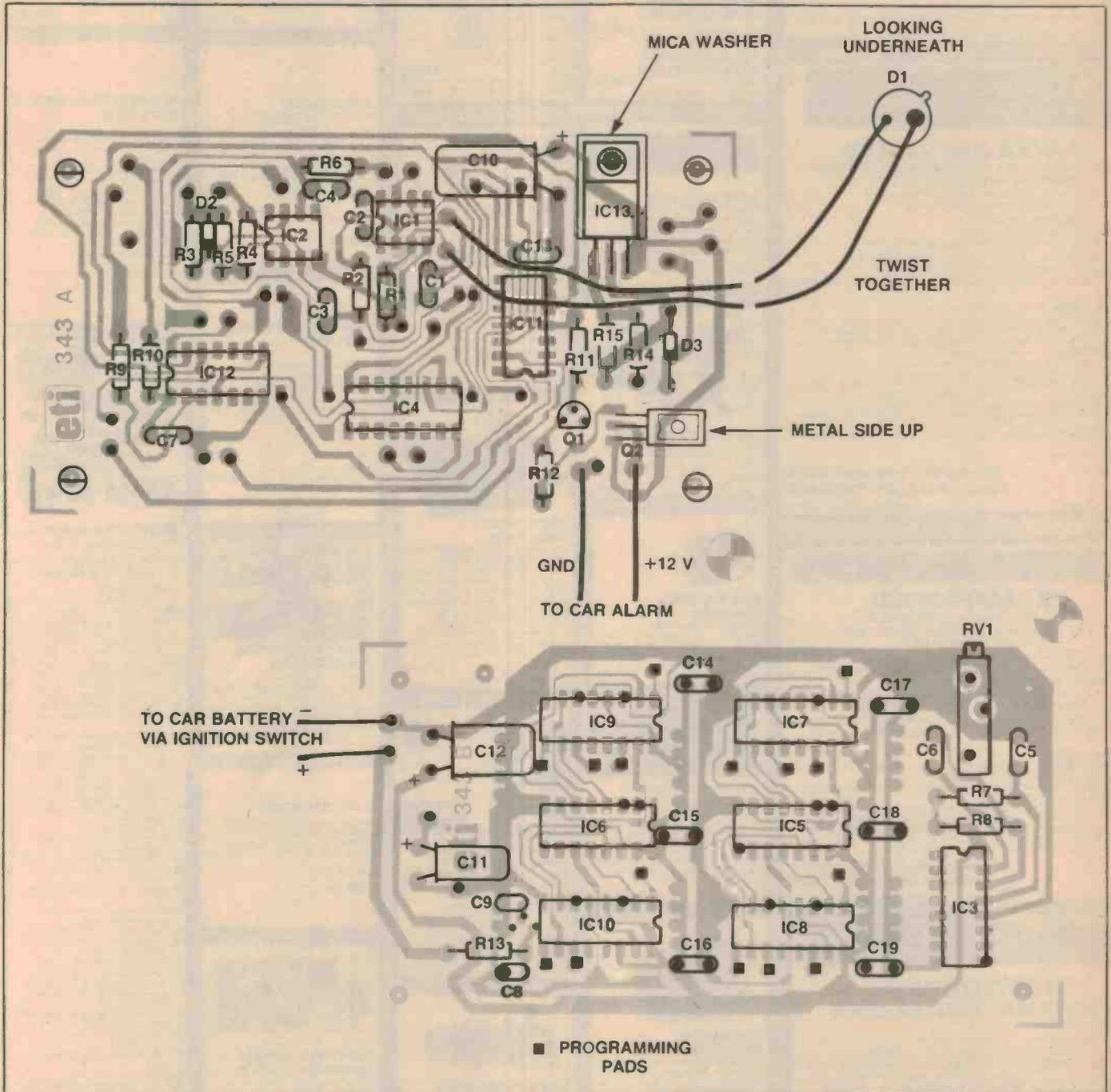

Take advantage of Rod prices, huge range

SERIES 5000

INDIVIDUAL COMPONENTS TO MAKE UP A SUPERB HI-FI SYSTEM!

By directly importing and a more technically orientated organisation, ROD IRVING ELECTRONICS can bring you these products at lower prices than their competitors. Enjoy the many other advantages of RIE Series 5000 kits such as "Superb Finish" front panels at no extra cost. Top quality components supplied throughout. Over 1,000 sold!

For those who haven't the time and want a quality hi-fi, we also sell the Series 5000 kits assembled and tested.

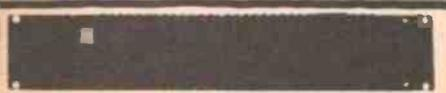

POWER AMPLIFIER

WHY YOU SHOULD BUY A "ROD IRVING ELECTRONICS" SERIES 5000 POWER AMPLIFIER...

- 1% Metal Film resistors are used where possible.
 - All components are top quality.
 - Over 1000 of these kits now sold.
 - Super Finish front panel supplied at no extra cost.
- Please note that the "Superb Quality" Heatsink for the Power Amplifier was designed and developed by ROD IRVING ELECTRONICS and is being supplied to other kit suppliers.

SPECIFICATIONS: 150 W RMS into 4 ohms
POWER AMPLIFIER: 100W RMS into 8 ohms (+ 55V Supply)
FREQUENCY RESPONSE: 8Hz to 20KHz +0 -0.4 dB 2 Hz to 65KHz.
 -0.3 dB NOTE: These figures are determined solely by passive filters
INPUT SENSITIVITY: 1 V RMS for 100W output
HUM: 100 dB below full output (flat)
NOISE: 116 dB below full output (flat, 20KHz bandwidth)
2nd HARMONIC DISTORTION: 0.001% at 1KHz (0.0007% on Prototypes) at 100W output using a + 56V SUPPLY rated at 4A continues -0.0003% for all frequencies less than 10KHz and all powers below clipping
TOTAL HARMONIC DISTORTION: Determined by 2nd Harmonic Distortion (see above)
INTERMODULATION DISTORTION: 0.003% at 100W (150Hz and 7KHz mixed 4:1)
STABILITY: Unconditional.

Cat. K44771 Normally \$319, now only \$289
 Assembled and tested \$499
 packing and post \$10



PREAMPLIFIER

THE ADVANTAGES OF BUYING A "ROD IRVING ELECTRONICS" SERIES 5000 PREAMPLIFIER KIT ARE...

- 1% Metal Film Resistors are supplied.
- 14 Metres of Low Capacitance Shielded Cable are supplied (a bit extra in case of mistake).
- English "Lorlin" switches are supplied (no substitutes here.)
- Specially imported black anodised aluminium knobs.
- Available Assembled and Tested. (We believe that dollar for dollar there is not a commercial unit available that sounds as good.)

SPECIFICATIONS:
FREQUENCY RESPONSE: High-level input, 15Hz - 130KHz +0.1 dB
 Low-level input conforms to RIAA equalisation + - 0.2dB
DISTORTION: 1KHz -0.003% on all inputs (limit of resolution on measuring equipment due to noise limitation)
SN NOISE: High-Level input, master full, with respect to 300mV input signal at full output (1.2V) -92dB flat -100dB A-weighted, MM input, master full, with respect to full output (1.2V) at 5mV input 50ohms source resistance connected -86dB flat -92dB A-weighted MC input, master full, with respect to full output (1.2V) and 200V input signal -71dB flat -75dB A-weighted

Cat. K44791 Normally \$289, now only \$249
 Assembled and tested \$599
 packing and postage \$10



THIRD OCTAVE GRAPHIC EQUALIZER

SPECIFICATIONS:
BANDS: 28 Bands from 31.5Hz to 16KHz.
NOISE: 0.008mV, sliders at 0 gain at 103dB0
20KHz BANDWIDTH DISTORTION: 0.007% at 300mV signal, sliders at 0 gain at 0, maximum 0.01%, sliders at minimum.
FREQUENCY RESPONSE: 12Hz = 105KHz, +0, = 1dB, all controls flat.
BOOST AND CUT: 14dB

Cat. K44590 1 Unit ... \$199
 2 Units ... \$379
 packing and postage \$10



50 W AMPLIFIER MODULE (ETI 480)
 Cat. K44880 \$27.50
 (Heatsink optional extra)

100 W AMPLIFIER MODULE (ETI 480)
 Cat. K44881 \$29.95
 (Heatsink optional extra)



150W BASS AMP
 This guitar amp for impeccable bass players features many facilities found on expensive commercial ones. It delivers 150 watts into 4-ohms, has a 1-band graphic limiter, line out and br-amp facilities.
 (ETI Aug '84) ETI 1410
 Cat. K54100 \$299



1W AUDIO AMPLIFIER
 A low-cost general-purpose 1 watt audio amplifier, suitable for increasing your computers audio level etc. (EA Nov '84)
 Cat. K84111 \$9.95



EA AM STEREO DECODER
 AM stereo is now broadcast in Australia on an experimental basis. This add-on decoder works with the Motorola C-QUAM system.
 (EA Oct '84) 84MS10
 Cat. K84101 \$27.50



STEREO ENHANCER
 The best thing about stereo is that it sounds good! The greatest stereo hi-fi system loses its magnificence if the effect is so narrow you can't hear it. This project lets you cheat on being cheated and creates an enhanced stereo effect with a small unit which attaches to your amp.
 (ETI 1405, ETI MAR '85)
 Cat. K54050 \$79.50

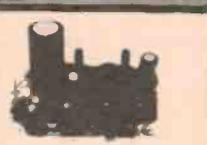

PARABOLIC MICROPHONE
 Build a low cost parabola, along with a high gain headphone amplifier to help when listening to those natural activities such as babbling brooks, singing birds or perhaps even more sinister noises. The current cost of components for this project is around \$15 including sales tax, but not the cost of batteries or headphones. (EA Nov '83) 83MA11
 Cat. K83110 \$15.00



MOSFET POWER AMPLIFIER
 Employing Hitachi Mosfets, this power amplifier features a "no compromise" design, and is rated to deliver 150 W RMS maximum and features extremely low harmonic, transient and intermodulation distortion.
 ETI 477 (ETI Jan. 81)
 Cat. K44770 \$79.50
 Plus power supply (No trans) \$49
 Plus transformer PF4361/1 \$49.50

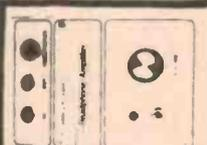

HEADPHONE AMPLIFIER PRACTICE WITHOUT ANNOYING THE FAMILY!
 If you play any type of electronic instrument this headphone amplifier will surely interest you. It will let you practice for hours without upsetting the household, or you can use it to monitor your own instrument in the midst of a rowdy jam session. (EA Feb '84) 83MA11
 Cat. K83011 \$28.00



300W "BRUTE" AMPLIFIER
 The "Brute" develops 300W into 4 ohms, 200W into 8 ohms! For many audio applications there is no substitute for sheer power - low efficiency speakers, outdoor sound systems, or maybe you like the full flavour of the dynamic range afforded by a high power amp. Whatever your requirement, this super power module should fill the bill. (ETI 466) (ETI Feb '80)
 Cat. K44660 \$79.50
 (Heatsink not included)



100W SUB-WOOFER AMPLIFIER
 Capable of up to 120 watts RMS into 4 ohm loads and up to 90 watts RMS into 8 ohm loads, this power amplifier module has been specifically designed for use as a sub-woofer driver amplifier in a hi-fi system. It uses four power Mosfets for rugged, reliable operation. (EA July '82) (82PA7)
 Cat. K82075 \$97.50



VOICE OPERATED RELAY
 EA's Great Voice Operated Relay can be used to control a tape recorder, as a VOX circuit for a transmitter or to control a slide projector. (EA Apr '82) 82VX4
 Cat. \$14.95



AUDIO TEST UNIT
 Just about everyone these days who has a stereo system also has a good cassette deck, but not many people are able to get the best performance from it. Our Audio Test Unit allows you to set your cassette recorder's bias for optimum frequency response for a given tape or alternatively, it allows you to find out which tape is best for your recorder. (81A090) (EA Oct '81)
 Cat. K81101 \$47.50

SERIES 4000 STEREO PREAMP

This high performance project is designed to complement ETI's 60 watt low distortion amplifier module and forms part of a complete stereo system, the "Series 4000" project. (ETI 471) (Top Projects Vol. 6)
 Cat. K44710 \$49.50

150W MOSFET POWER AMPLIFIER

Here's a high power, general purpose 150W Mosfet Power Amp Module! Suitable for guitar and P.A. applications and employing rugged reliable Mosfets in the output stage. (ETI 499) (ETI March '82)
 Cat. K44990 \$79
 (Heatsink not included) plus transformer \$49.50



GENERAL PURPOSE PREAMPLIFIER
 A general purpose stereo preamplifier using a single LM382 IC which can be tailored for use with magnetic pickups, tape recorders or microphones by changing a few components. (ETI 445) (ETI July '76)
 Cat. K44490 \$8.95

4 INPUT PREAMP

Easy construction and versatile operation, this preamp is for coupling with the 300W Brute Power Amp. (ETI 467) (ETI July '80)
 Cat. K44670 \$26.50



GENERAL PURPOSE AMPLIFIER CLASS B
 One of the handiest "tools" for the electronics experimenter is a genuine purpose audio amp. This module will work from a wide range of supply voltages, has good sensitivity, is robust and reliable - easy to build too! (ETI 453) (ETI April '80)
 Cat. K44530 \$24.50



MUSICOLOR IV
 Add excitement to parties, card nights and discos with EAS Musicolor IV light show. This is the latest in the famous line of musicolors and it offers features such as four channel "color organ" plus four channel light chaser, front panel LED display, internal microphone, single sensitivity control plus opto-coupled switching for increased safety. (EA Aug '81) 81MCS
 Cat. K81080 \$99.00

PLAYMASTER 300 WATT AMPLIFIER

This module will deliver up to 200 watts into an 8 ohm load and up to 300 watts into a 4 ohm load. Comprehensive protection is included and a printer circuit board brings it all together in a rugged easy-to-build module. It can be built in either fully-complementary or quasi-complementary versions, so output transistor shortages should be no problem at all. (80PA6) (EA July '80)
 Cat. K80060 \$63



MICROBEE ENHANCER 1

This brand new, totally amazing kit for the Microbee is a must for all Microbee owners/users! Most expansion units up to this time offered at best only one or other features, and this made it impossible to run, say, complex sound effects mixed with speech. The Enhancer 1 will do all this and much more as well. It is quite amazing how much has been shoe-horned into this compact unit. The Enhancer 1 is many powerful features include:

- Two ATARI/COMMODORE COLECO/SEARS type joystick inputs
- Two TRS COLOR COMPUTER type joystick inputs
- Allows the connection of Touch Pads, Paddles, Proportional Joysticks, Trakkals, Mice
- Temperature sensors, lights level sensors, transducers, etc. etc!
- A 4 voice music-sound effects synthesizer
- A real time clock
- Unlimited vocabulary speech synthesizer (option)
- Parallel printer interface (option)
- A built-in speaker with volume control
- Listings of all necessary routines for use
- An impressive demonstration program package
- Compatible to all Microbees
- Digital recording and playback of speech and sound
- An 8 channel analog to digital converter with variable voltage or variable resistance type analog inputs and also user selectable resolution from 1 to 9 bits
- A digital to analog converter with selectable resolution from 1-8 bits
- Allows automatic data acquisition and logging
- 5 digital input lines, 4 digital output lines
- A voice input channel
- A 40 pin experimenter socket with all 8 analog inputs, 5 digital inputs, 4 digital outputs, 3 58 MHz buffered clock, sound output (so that you can play the sound effects through your HI-FI), 3 high resolution voltage comparators, DAC output etc

Cat. \$149

Driving Electronics' great and quality service!

PLEASE NOTE NEW MAIL ORDER PHONE No.



300 BAUD DIRECT CONNECT MODEM
Modem? What do I want with a modem? Think of these advantages:

- Can't afford a floppy disc? Use your telephone to access one for the cost of a call
- Bored with your old programs? Download hundreds of free programs
- Want to get in touch with fellow computer enthusiasts? Use electronic mail
- Ever used a CP-M system? CP-DOS? UNIX? Well a modem will make a your computer a remote terminal on some of the most exciting systems around

Save on ready built modems.
 Cat. \$99



PARALLEL PRINTER SWITCH
 Tired of plug swapping when ever you want to change from one printer to another? This low cost project should suit you down to the ground. It lets you have two Centronics type printers connected up permanently, so that you can select one or the other at the flick of a switch.
 (ETI 666, Feb '85)
 Cat. #46660 \$69.95



COMPUTER DRIVEN RADIO-TELETYPE TRANSCIVER
 Here's what you've been asking for, a full transmit/receive system for computer driven radio teletype station. The software provides all the latest "whizz-bangs" like split-screen operation, automatically repeating test message, printer output and more. The hardware uses tried and proven techniques. While designed to team with the popular Microbee, TOS are available on interfacing the unit to other computers.
 (ETI Nov '84) ETI 755
 Cat. #K47550 \$139.00

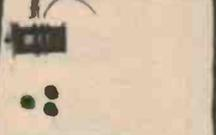

PH METER KIT
 Build this pH meter for the swimming pool season is here again! From swimming pools to fish tanks to gardening, this pH meter has many applications around the home. This unit features a large 3 1/2 digit liquid crystal display and resolution to 0.1 pH units, making it suitable for use in the laboratory as well.
 (EA Dec '82) 82PH12
 Cat. #K82123 \$139



DUAL TRACKING POWER SUPPLY
 Built around positive and negative 3-Terminal Regulators, this versatile dual tracking Power Supply can provide voltages up to 2A. In addition the Supply features a fixed +5V 0.9A output and is completely protected against short circuits, overloads and thermal runaway.
 (EA March '82) 82PS2
 Cat. #K82030 \$87.50



ELECTRIC DUMMY LOAD
 With this unit you can test power supplies at currents up to 15 Amps and voltage up to 60 Volts. It can "sink" up to 200 Watts on a static test and you can modulate the load to perform dynamic tests.
 (ETI Oct '80) ETI 147
 Cat. #K41470 \$109



MOTORCYCLE INTERCOM
OVER 300 SOLD!
 Motorcycling is fun, but the conversation between rider and passenger is usually just not possible. But build this intercom and you can converse with your passenger at any time while you are on the move. There are no "push-to-talk" buttons, adjustable volume and it's easy to build!
 (EA Feb '84) 84MC2
 Cat. #K804020 \$45.00



ELECTRONIC MOUSETRAP
 This clever electronic mousetrap disposes of mice instantly and mercifully, without fail, and resets itself automatically. They'll never get away with the cheese again!
 (ETI Aug '84) ETI 1524
 Cat. #K55240 \$32.50



EPROM PROGRAMMER EP1
 No need for a Micro with EA's great Eprom Programmer suitable for 2716/2758 Eproms.
 (EA Jan '82) 82EP1
 Cat. #K82013 \$47.50
 With Testtool Socket \$59.95

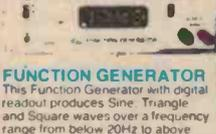

FUNCTION GENERATOR
 This Function Generator with digital readout produces Sine, Triangle and Square waves over a frequency range from below 20Hz to above 160Hz with low distortion and good envelope stability. It has an inbuilt four digit frequency counter for ease and accuracy of frequency setting.
 (EA April '82) 82A03A(B)
 Cat. #K82041 \$87.50



LAB SUPPLY
 Fully variable 0-40V current limited 0-5A supply with both voltage and current metering (two ranges: 0-0.5A/0-5A). This employs a conventional series-pass regulator, not a switchmode type with its attendant problems, but dissipation is reduced by unique relay switching system switching between taps on the transformer secondary.
 (ETI May '83) ETI 163
 Cat. #K41630 \$175.00



BIPOlar PROM PROGRAMMER
 Every digital work shop should have one! Can be used to program the popular fusible-link PROMs like the 74S188/268, 82S23 & 82S123 etc.
 (ETI June '83) ETI 688
 Cat. #K46880 \$49.50



EPROM PROGRAMMER
 If you have ever wanted to rewrite or extend the operating system of your microcomputer or if you're interested in dedicated microprocessor applications then this EPROM Programmer is just the thing. It is an inexpensive unit that uses readily available IC's, interfaces directly to the expansion bus on the back of all the popular 8080 Z80 microcomputers and programs 2708's, 2716's, 2758's and 2732's. (EA July '80) 80PP71
 Cat. \$79.50
 (Horwood case supplied)



TRANSISTOR TESTER
1000's SOLD
 Have you ever desoldered a suspect transistor, only to find that it checks OK? Trouble-shooting exercises are often hindered by this type of false alarm, but many of them could be avoided with an "in-circuit" component tester, such as the EA Handy Tester. (EA Sept '83) 83TTR
 Cat. #K83080 \$15.00



MICROBEE SERIAL-TO-PARALLEL INTERFACE
 Most microcomputers worth owning have an 'RS232' connector or port, through which serial communications (input/output) is conducted. It is a convention that, for listing on a printer, the BASIC LLIST or LPRINT command assumes a printer is connected to the RS232 port. Problem is, serial interface printers are more expensive than parallel Centronics interface printers. Save money by building this interface. (ETI Jan '84) ETI 675
 Cat. #K46750 \$59.00



LOW OHMS METER
 How many times have you cursed your Multimeter when you had to measure a low-value resistance? Well with the "Low Ohms Meter" you can solve those old problems and in fact measure resistance from 100 Ohms down to 0.005 Ohms.
 (ETI Nov '81) ETI 158
 Cat. #K41580 \$39.50



30 V/1 A FULLY PROTECTED POWER SUPPLY
 The last power supply we did was the phenomenally popular ETI-131. This low cost supply features full protection, output variation from 0V to 30V and selectable current limit. Both voltage and current metering is provided.
 (ETI Dec. '83) ETI 162
 Cat. #K41620 \$52.50



ROD IRVING ELECTRONICS
 425 High Street, NORTHCOLE, 3070 VICTORIA, AUSTRALIA
 Phone (03) 483 8866
 48-A Beckett St, MELBOURNE 3000 VICTORIA, AUSTRALIA
 Ph. (03) 663 6151
 Mail Order and correspondence: P.O. Box 620, CLAYTON 3168
 TELEX. AA 151938

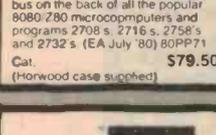

MULTI SECTOR ALARM STATION
 Protect your home from intruders with this up-to-the-minute burglar alarm system, its easy to build, cost less than equivalent commercial units, and features eight separate inputs, individual sector control, battery back up and self-test facility.
Specifications:

- Eight sectors with LED status indication
- Two delayed entry sectors
- Variable exit, entry and alarm time settings, entry delay variable between 10 and 75 seconds, exit delay variable between 5 and 45 seconds, alarm time variable between 1 and 15 minutes
- Resistive loop sensing, suits both normally open and normally closed alarm sensors
- Battery back up with in-built charger circuit
- Built-in siren driver

Complete kit including deluxe prepunched metal work and electronics for only...
 Cat. #K85900 \$119



LOW-COST BIPOLAR MODEL TRAIN CONTROLLER
 Here is a simple model train control for those enthusiasts who desire something better than the usual rheostat control. It provides much improved low speed performance and is fully overload protected, yet contains relatively few components. Best of all, you don't need to be an electronic genius to construct it.
 (BOTC12) (EA Dec '80)
 Cat. #K80120 \$34.50

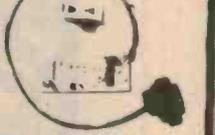

RADIOTELETYPE CONVERTER FOR THE MICROBEE
 Have your computer print the latest news from the international shortwave news service. Just hook up this project between your short wave receivers audio output and the MicroBee parallel port. A simple bit of software does the decoding. Can be hooked up to other computers too. (ETI Apr '83)
 Cat. \$19.95

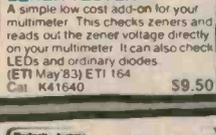

ZENER TESTER
 A simple low cost add-on for your multimeter. This checks zeners and reads out the zener voltage directly on your multimeter. It can also check LEDs and ordinary diodes.
 (ETI May '83) ETI 164
 Cat. #K41640 \$9.50



15V DUAL POWER SUPPLY
 This simple project is suitable for most projects requiring a dual voltage.
 (ETI 581, June '76)
 Cat. \$17.50



MAIL ORDER HOTLINE
 (03) 543 7877
 (2 lines)

POSTAGE RATES

\$1-\$9.99	\$2.00
\$10-\$24.99	\$3.00
\$25-\$49.99	\$4.00
\$50-\$99.99	\$5.00
\$100-\$199	\$7.50
\$200-\$499	\$10.00
\$500 plus	\$12.50

This is for basic postage only. Comet Road freight, bulky and fragile items will be charged at different rates.
 Certified Post for orders over \$100 included "Free"
 Registered Post for orders over \$200 included "Free"

MasterCard VISA

Errors and Omissions Excepted.



LOW BATTERY VOLTAGE INDICATOR
 Knowing your batteries are about to give up on you could save many an embarrassing situation. This simple low cost project will give you early warning of power failure, and makes a handy beginner's project.
 (ETI 280, March '85)
 Cat. #K42800 \$7.95



CAR IGNITION KILLER
 Most car burglar alarms are easily circumvented, but not this cunning "Ignition Killer". This sneaky anti-theft device uses a 555 timer to place an intermittent short circuit across the points. Until disabled by its hidden switch the circuit effectively makes the car undrivable — a sure deterrent to thieves!
 (EA Aug '84) 84AU1
 Cat. #K84010 \$16.95
 (Our kit includes the box!)



VIDEO ENHANCER
 100's SOLD
 Like tone controls in a hi-fi amplifier, touch up the signal with this Video Enhancer.
 (EA Oct '83) 83VE10
 Cat. #K83100 \$35.00



VIDEO AMPLIFIER
 Bothered by smeary colours, signal beats and RF interference on your computer display? Throw away that cheap and nasty RF modulator and use a direct video connection instead. It's much better! The Video Amplifier features adjustable gain and provides both normal and inverted outputs. Power is derived from a 12V DC plugpack supply.
 (EA Aug '83) 83VAB
 Cat. #K83081 \$17.50



SOUND SIMULATOR FOR MODEL TRAINS
 Fancy a diesel sound simulator for your model train layout? This circuit mounts inside the train for added realism and even varies its 'speed' according to the throttle setting.
 (EA Nov '84)
 Cat. #K84110 \$18.00

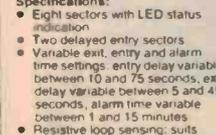

MULTI SECTOR ALARM STATION
 Protect your home from intruders with this up-to-the-minute burglar alarm system, its easy to build, cost less than equivalent commercial units, and features eight separate inputs, individual sector control, battery back up and self-test facility.
Specifications:

- Eight sectors with LED status indication
- Two delayed entry sectors
- Variable exit, entry and alarm time settings, entry delay variable between 10 and 75 seconds, exit delay variable between 5 and 45 seconds, alarm time variable between 1 and 15 minutes
- Resistive loop sensing, suits both normally open and normally closed alarm sensors
- Battery back up with in-built charger circuit
- Built-in siren driver

Complete kit including deluxe prepunched metal work and electronics for only...
 Cat. #K85900 \$119



LOW BATTERY VOLTAGE INDICATOR
 Knowing your batteries are about to give up on you could save many an embarrassing situation. This simple low cost project will give you early warning of power failure, and makes a handy beginner's project.
 (ETI 280, March '85)
 Cat. #K42800 \$7.95



VIDEO AMPLIFIER
 Bothered by smeary colours, signal beats and RF interference on your computer display? Throw away that cheap and nasty RF modulator and use a direct video connection instead. It's much better! The Video Amplifier features adjustable gain and provides both normal and inverted outputs. Power is derived from a 12V DC plugpack supply.
 (EA Aug '83) 83VAB
 Cat. #K83081 \$17.50



VIDEO ENHANCER
 100's SOLD
 Like tone controls in a hi-fi amplifier, touch up the signal with this Video Enhancer.
 (EA Oct '83) 83VE10
 Cat. #K83100 \$35.00



SOUND SIMULATOR FOR MODEL TRAINS
 Fancy a diesel sound simulator for your model train layout? This circuit mounts inside the train for added realism and even varies its 'speed' according to the throttle setting.
 (EA Nov '84)
 Cat. #K84110 \$18.00

Banknote Visa MasterCard Signature Name Address P Code ETI 1085

Project 343

did not give one false trigger while the car was moving, even when it was 'on'.)

Turning off the engine should energise the switch, thus connecting the 12 V back to your car alarm system immediately. Of course, an exit delay has to be allowed, otherwise you would trigger the alarm as soon as the engine was turned off. Read the construction section for more on entry/exit delays.

The receiver oscillator is free running, regardless of other signals, and is fed by the divider, which is normally reset. The divider is controlled by a monostable. Upon reception of the first start bit, the monostable is activated, and its output releases the divider which outputs a pulse after 128 clock pulses from the oscillator.

The monostable is arranged in a reseta-ble mode with a 100 millisecond timing period. Timing starts as soon as the first start bit activates it. Before the 100 milliseconds expire, any other 1s in the code stream will refresh the timing period back to 100 milliseconds. That is, so long as the transmission continues, the received 1s will keep the monostable and the divider active. When

TABLE 3a. COMPONENT MOUNTING METHODS

	Surface Mount	Semi-surface Mount	Normal Mount
ICs	1, 2, 4, 11, 12, 13	3, 5, 6, 7, 8, 9, 10	none
Transistors	Q2	none	Q1
Capacitors	1, 2, 3, 4, 5, 6, 7, 9, 11, 13	8, 10	12, 14, 15, 16, 17, 18, 19
Resistors	1, 2, 3, 4, 5, 6, 7, 8, 9, 10, 11, 12, 13, 15	14	none
Diodes	D2	D3	none

the transmission stops, the monostable times out after 100 milliseconds and resets the divider. No more sampling is allowed, and the circuit goes back to the listening mode.

Recall that the matching circuit is continually matching the two sets of codes, one from the shift register, which is sliding across the other set, fixed by programming. If, at any instance, the two sets match, an 'equal' signal is sent to stop the divider.

The power supply section is designed around the LM317 regulator. Since the output voltage affects the oscillator frequency, high stability resistors must be used to program the regulator output voltage. Another

point to notice: CMOS chips with the same number sometimes don't have the same characteristics. Take for example the 40106B Schmitt inverter, where threshold voltages differ from manufacturer to manufacturer. An SGS brand 40106 *must* be used in this project. Anyone who is doubtful should refer to the article 'Some CMOS circuits don't always work' in ETI July 83.

Construction and installation

Construction of the circuit is basically assembling the pc board; there is no fancy box to fiddle with and there is no front panel to drill. Perhaps I should be fair and mention the hidden overhead — installation of the

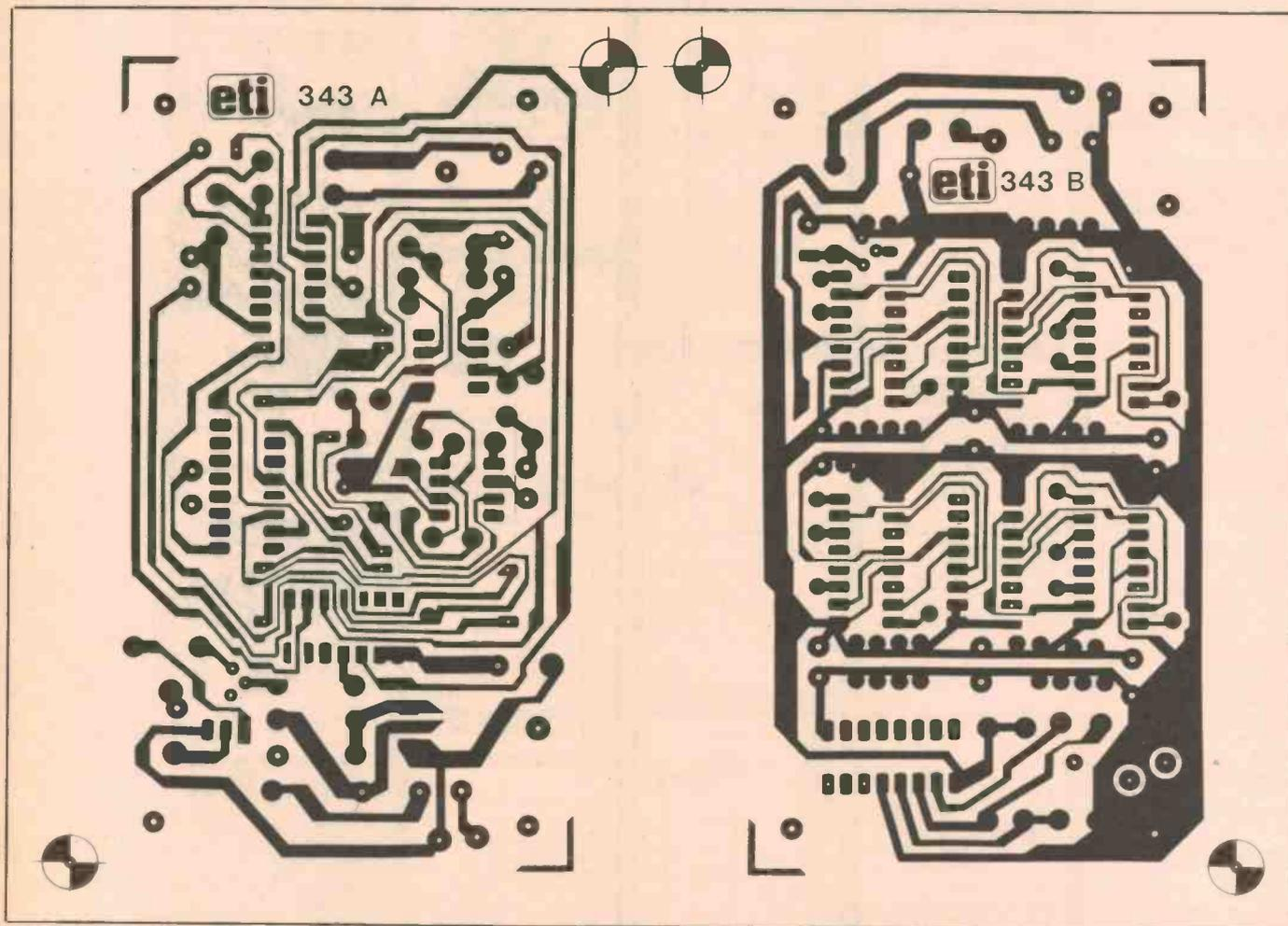

TABLE 3b. IC PINS RESERVED

ICs	Uncut Pins	Cut Pins
1, 2, 4, 11, 12, 13	—	all
3	8, 11	all remaining
5	2, 3, 9	all remaining
6	2, 3	all remaining
7	3	all remaining
8, 9, 10	3, 6	all remaining

unit. Don't panic, it is a natural consequence of building any car projects.

If you are an experienced hobbyist, you will find that the way the pc board is assembled here is slightly unusual. The ways in which the components are soldered onto the board can be classified into three groups: surface mount, semi-surface mount, and the normal mount. Components belonging to the first group have all their pins chopped to the right length and soldered directly onto the pads (see Figure 5). The second group of components have some of their pins chopped and soldered on to the pads; the rest are done in the usual way. For example, all the pins of IC5 are chopped and soldered using the surface mount technique except pins 2, 3 and 9. These should go through holes on the pads and be soldered on to the other side of the board. As the name implies, the components from the normal mount group have all their pins going through holes on the board.

Table 3 displays the classification of all the components in this project. It looks easy but you have to be very careful before you put the components on the board. Cutting the wrong pin simply wastes a component. You may be delighted to hear that no feed-through wires are used. Well, strictly speaking, they are, but all of them are just the pins of components, and are used to join tracks together on both sides of the board. Therefore, whenever a pin goes through a hole on the board, don't forget to check whether it has to be soldered on both sides or not. The general rule is simple. Any side with a track connecting the pad requires that side of the pad to be soldered on the pin.

Everyone knows that when the ignition key is in the 'on' position, power supply (12 V battery) is connected to things like the radio or cigarette lighter in your car. Turning it to the 'off' position simply turns everything off. The ETI-343 has to be installed exactly the opposite way. This is quite possible because turning your ignition key is in fact turning a multi-tapped switch. The switch provides complementary terminals very much like a double pole relay with normally open and normally close contacts. The wires already connected to the existing alarm are probably the ones that you are trying to connect. Disconnect them from your alarm and connect them to the ETI-343 circuit as shown on the overlay. If you

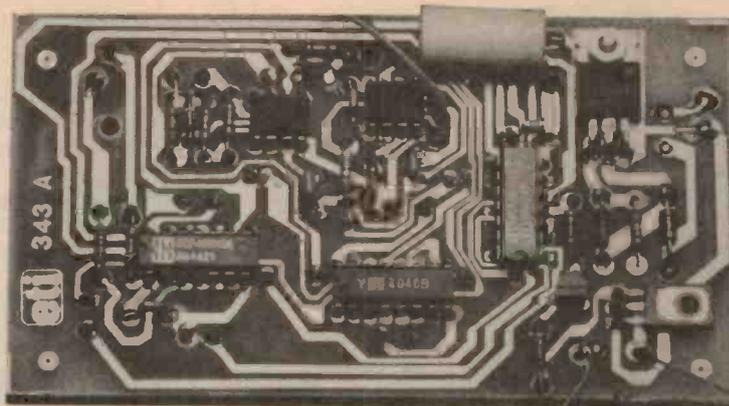

Side A assembly of the printed circuit board.

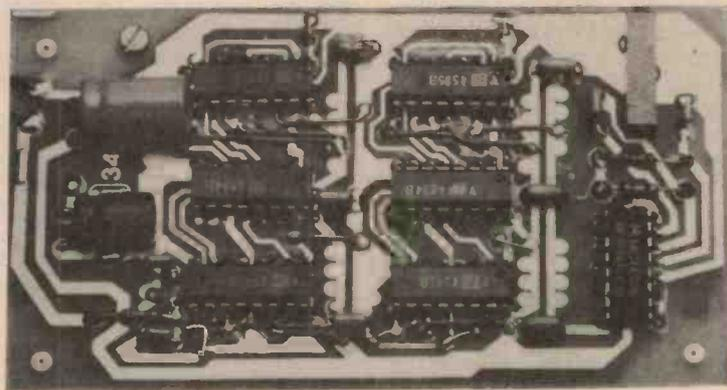

Side B assembly of the printed circuit board.

are a greenhorn in cars, an auto electrician should be consulted.

Car alarms normally have separate controls for entry and exit delays. Simply adjust the entry delay to minimum, or, if possible, to instant, and leave the exit delay alone. Other products have one control over the two delays plus an instant alarm input. In such cases, do not adjust the delay time but reconnect the wires from the delay input to the instant input to your alarm.

The reed switches and sensors that detect the opening of the boot or the bonnet are usually connected to the instant input. Sensors to detect the opening of the doors are usually to the delay input. All you have to do is to connect all the sensors to the instant input. Since exit delay is unchanged, you can leave the car at your usual pace.

The light sensing diode works best when it is in the dark. To avoid sunlight shining on it directly, the sensor is put into a short section of black thermal heatshrink tube, in much the same way as the lens hood of a camera shields the lens. The sensor is mounted somewhere conveniently close to the window (see the photograph). Wires connecting the sensor to the motherboard should be twisted and made as short as practically possible. The motherboard can

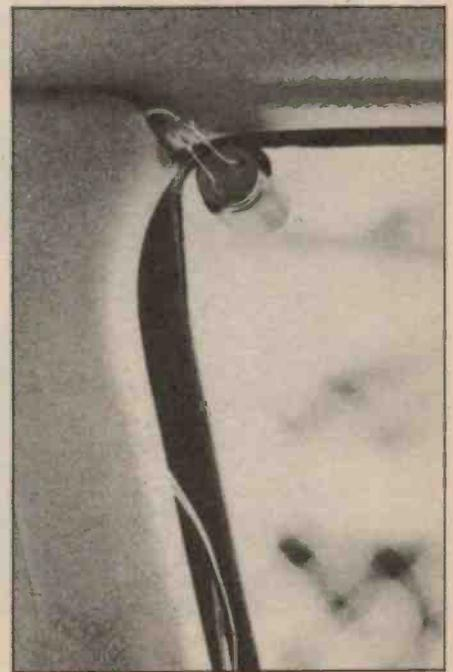

The sensing diode (with spaghetti) should be mounted right behind the window for easier operation.

Project 343

be hidden inside the dashboard or somewhere near your car alarm.

Testing and setting up

When you have finished building the board, as usual, check the resistance between the positive and negative rails. If the resistance is too low, you'd better check the polarity of all the diodes, electrolytic capacitors and the ICs. If the resistance is OK, you can connect a normal red LED in series with a 470 ohm resistor to the collector of Q2 and ground. The LED is a temporary load while you are testing the circuit on the bench. See Figure 6 for the connection. Now connect the 12 V battery to the circuit and the LED should light up.

Turn RV1 clockwise until you can hear a clicking noise. RV1 is now at its minimum resistance. Turn on your transmitter a few centimetres away from the sensor. If the dummy load (LED) does not turn off, stop the transmission and turn RV1 anti-clockwise (increasing resistance) by a small amount. Turn on the transmitter again to see whether the dummy load is triggered. If not, repeat the same procedure until it does trigger. RV1 now has the minimum workable resistance. Unsolder RV1 carefully without touching the tuning screw on it. Measure the resistance between the middle

pin and its nearest pin. Note the resistance and carefully solder it back on to the board. The idea is to repeat the same procedure until the maximum workable resistance is found, then the resistance of RV1 is set back half way between the two, giving you equal tolerances against positive and negative drift in the oscillator.

To find the maximum workable range, first turn RV1 anti-clockwise fully until the clicking noise is heard. Reset the circuit by disconnecting the battery. Due to the high protection on board against voltage spikes, the circuit does not reset immediately on disconnecting the power. It requires 40 seconds or more. You can, if you are impatient, short circuit the positive and the negative rails on the board with a piece of wire *after* the battery has been disconnected. Now connect the battery back to the circuit and the dummy load should light up. Turn the transmitter on and see whether the dummy load gets turned off. If not, adjust RV1 clockwise slightly (decreasing resistance) and turn on the transmitter again. Repeat the procedure until the dummy load triggers. As before, unsolder the pot carefully and measure its resistance. This is your maximum workable resistance. Set the resistance half-way between the two and solder the pot back.

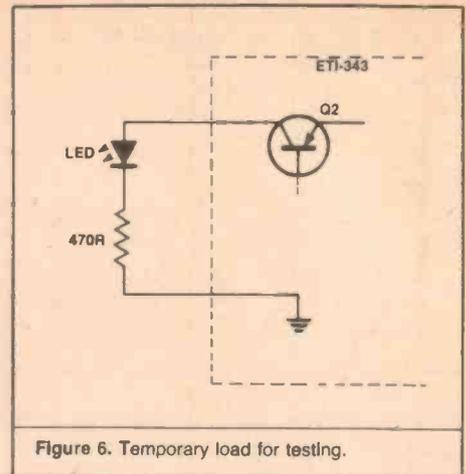

Figure 6. Temporary load for testing.

If nothing happens over the whole range of RV1, debugging time has begun! Check pin 6 of IC1 to see if pulses are there when you transmit signals to the sensing diode (D1). If not, it is most likely due to the wrong polarity of D1. Check pin 6 of IC2. Full digital pulses should appear there. As soon as you transmit, voltage at pin 9 of IC3 should go low and clock pulses should appear on pin 3 of IC5 and IC6. Pin 4 of IC12 should be oscillating all the time. Normally, pin 3 of IC10 is at low. It goes high when the correct code is received. If a high on this pin does not turn the dummy LED off, check the pins of Q1, Q2, or even the polarity of the dummy LED.



Sealed lead acid & nickel cadmium rechargeable batteries

MAINTENANCE FREE



COMPLETE RANGE OF BUTTON CELL STACKS assembled in Australia to customers specifications.



I.E.I. (AUST.) PTY. LTD.

15-17 Normanby Road, Clayton, Vic. 3149 Phone (03) 544 8411
31 Phillips Street, Thebarton, S.A. 5031 Phone (08) 352 2066
248 Johnston Street, Annandale, N.S.W. 2038 Phone (02) 692 0999

You've only waited twenty years . . .
but it's been worth the wait!

HERE AT LAST: HF TRANSCEIVER TO BUILD!

- Better than 0.3uV sensitivity (10dB S+N/N)
- Selectivity 6dB at 4kHz, 60dB at 7kHz
- Better than 50dB image rejection
- SSB and CW transmission — keep that speed up!



- 12 Volt operation — mobile or shack, it's ready for you!
- Full 30 watts out put (SSB) — just right for the novice!
- Better than +60dB harmonic suppression
- And much, much more.

It's been over twenty years since Electronics Australia described a complete, build-it-yourself HF transceiver . . . but the wait was well worth it!

From the same designers that brought you the incredibly popular build-it-yourself VHF "Explorer" and UHF "Commander" transceiver kits comes the very latest: CW/SSB transceiver which can cover any 500kHz segment between 2 and 30MHz.

Remember the good old days when "home brew" was half the fun? Now you can get back into home brew again — without spending a fortune. Building it is half the fun — without the headaches! Our specially prepared step-by-step instruction manual means it should be within the capabilities of most amateur hobbyists. And just in case, our exclusive "satisfaction guarantee" protects you: before you start con-

Cat K-6330



ALL THIS FOR ONLY \$349

struction you can return the kit (in original condition & packing) for a full refund!

It's 12 volt operated — so it's perfect for mobile or shack operation. And it's digital: the display shows your frequency (great when driving) and all controls have been simplified for ease of mobile or bench use!

And it's incredibly economical, especially for those who like one particular band — you simply build it for the band you want!

Now you can have that transceiver you've always wanted! But that's not all!

Every kit comes complete with our specially moulded high impact ABS case to protect your transceiver, together with silk-screened front panel and microphone!

It looks so good your friends will never believe you built it!

Hurry: limited stock!

Some of the special components in this transceiver are difficult to get. Stocks are limited — and at the low, low price of this kit they're sure to disappear fast. Place your order now at your nearest Dick Smith Electronics store!

As described in EA October & November.

DICK SMITH ELECTRONICS



PTY LTD

B037

IDEA OF THE MONTH

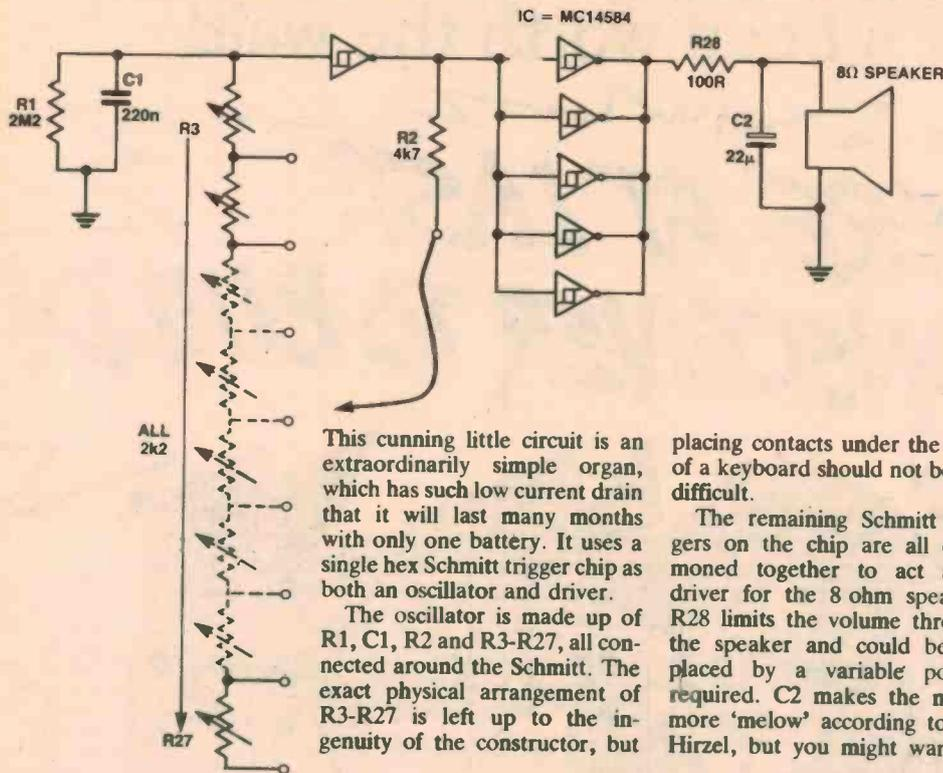

Electronic organ

A Hirzel Titirangi,
Auckland 7 NZ

This cunning little circuit is an extraordinarily simple organ, which has such low current drain that it will last many months with only one battery. It uses a single hex Schmitt trigger chip as both an oscillator and driver.

The oscillator is made up of R1, C1, R2 and R3-R27, all connected around the Schmitt. The exact physical arrangement of R3-R27 is left up to the ingenuity of the constructor, but

placing contacts under the keys of a keyboard should not be too difficult.

The remaining Schmitt triggers on the chip are all commoned together to act as a driver for the 8 ohm speaker. R28 limits the volume through the speaker and could be replaced by a variable pot if required. C2 makes the music more 'mellow' according to Mr Hirzel, but you might want to

experiment with this.

Notice that when the circuit around IC1a is broken, ie, when no keys are depressed, R1 pulls the input down to zero. There is thus no output into the driver stage, and no current flows through the speaker. Thus the only current drain is through the MC 14584, of the order of a few microamps.

'IDEA OF THE MONTH' CONTEST

Scope Laboratories, which manufactures and distributes soldering irons and accessory tools, is sponsoring this contest with a prize given away every month for the best item submitted for publication in the 'Ideas for Experimenters' column — one of the most consistently popular features in ETI Magazine. Each month we will be giving away a 60 W Portable Cordless Soldering Iron, a 240 Volt Charging Adaptor together with a Holder Bracket. The prize is worth approx. \$100.

Selections will be made at the sole discretion of the editorial staff of ETI Magazine. Apart from the prize, each person will be paid \$20 for an item published. You must submit original ideas of circuits which have not previously been published. You may send as many entries as you wish.

COUPON

Cut and send to: Scope/ETI 'Idea of the Month' Contest, ETI Magazine, P.O. Box 227, Waterloo NSW 2017.

"I agree to the above terms and grant *Electronics Today International* all rights to publish my idea in ETI Magazine or other publications produced by it. I declare that the attached idea is my own original material, that it has not previously been published and that its publication does not violate any other copyright."

* Breach of copyright is now a criminal offence.

Title of Idea

Signature Date

Name

Address

Postcode



RULES

This contest is open to all persons normally resident in Australia, with the exception of members of the staff of Scope Laboratories, The Federal Publishing Company Pty Limited, ESN, The Litho Centre and/or associated companies.

Closing date for each issue is the last day of the month. Entries received within seven days of that date will be accepted if postmarked to and including the date of the last day of the month.

The winning entry will be judged by the editor of ETI Magazine, whose decision will be final. No correspondence can be entered into regarding the decision.

The winner will be advised by telegram the same day the result is declared. The name of the winner, together with the winning idea, will be published in the next possible issue of ETI Magazine.

Contestants must enter their names and addresses where indicated on each entry form. Photostats or clearly written copies will be accepted but if sending copies you must cut out and include with each entry the month and page number from the bottom of the page of the contest. In other words, you can send in multiple entries but you will need extra copies of the magazine so that you send an original page number with each entry.

This contest is invalid in states where local laws prohibit entries. Entrants must sign the declaration on the coupon that they have read the above rules and agree to abide by their conditions.

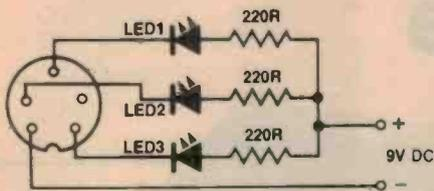

REAR VIEW OF
A 5-PIN DIN SOCKET
SUIT HI-GAIN CB

Mic lead tester

This circuit from W. Slabicki of Heyfield Vic, allows you to test a microphone and cable dynamically. The circuit can be mounted on top of a DIN plug and operates by sending dc

down the cable. The condition of the line is shown by the LEDs. LED1 proves the PTT wire, LED2 proves the speaker wire and LED3 proves the microphone wire.

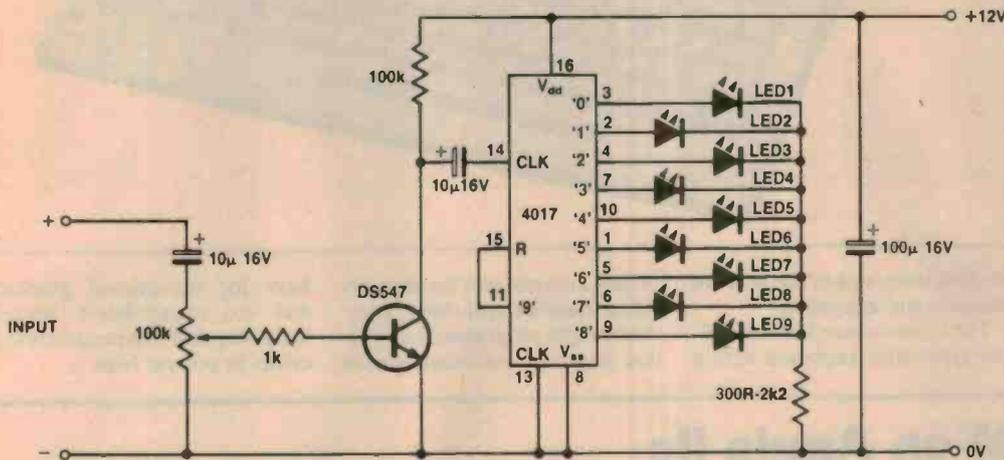

Sound light unit

This is a fun audio project you might care to try one wet Sunday afternoon. It comes from Trevor Ho of Cremorne in Sydney. The input is driven by a microphone. Changes in the value of the input cause the clock on pin 14 to be driven high or low. The 4017 responds by cycling through the LEDs so that the faster things change on the outside the faster the LEDs turn on and off.

Noise gate

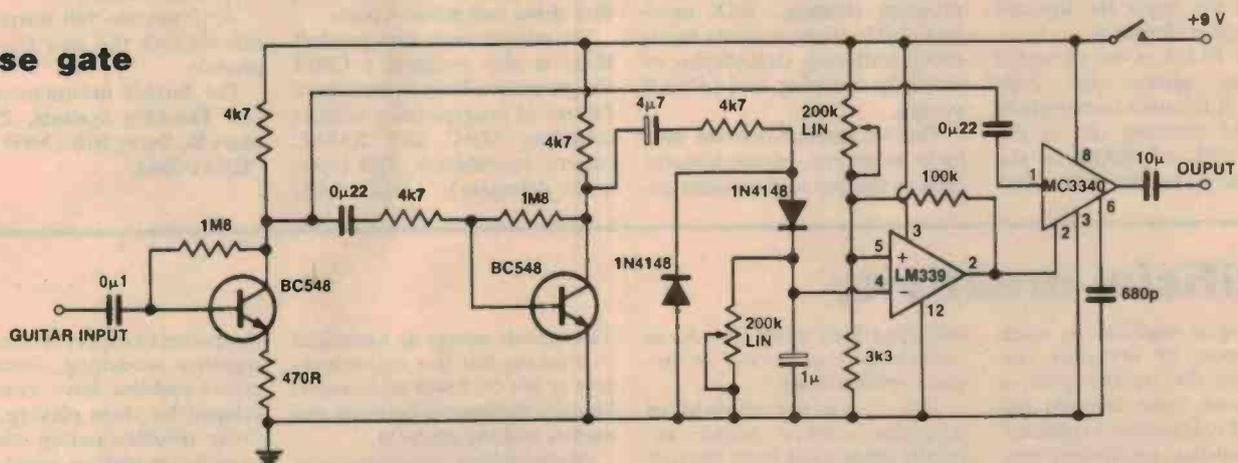

You can try this one on for size if you are having trouble with noisy guitar amplifiers. Problems of noise are only apparent when one is not playing a note. It's the pauses between the notes where the noise counts.

As a result, Geoff Cordick of

Tarnagulla Vic, came up with this noise gate which allows normal amplification when there is signal on the input, but kills it when there is no signal. The core of the circuit is the voltage doubler, made up of the two diodes and the 1 µF

capacitor. This produces a dc level which is fed to IC1, and compared with the level on pin 5, set by VR1. If this voltage falls below the reference, an output appears on pin 2, causing the output of IC1 to go to ground, thus shutting off the

amplifier. If the voltage on pin 3, IC2 is zero then slight amplification of the input occurs via Q1, the 0.22 µF capacitor and the op-amp. Q2 acts as an amplifier for the input signal which is fed to the comparator.

128K Commodore

Commodore Business Machines Pty Ltd has begun shipment of the Commodore 128 Personal Computer, which is compatible with all existing Commodore 64 software.

This compatibility is an important factor for the Australian market because of the great variety of Commodore 64 software already in use.

Other features of the Commodore 128 include a 128K memory (expandable to 512K), full colour 80 column display, and the availability of a full range of powerful peripherals. Commodore's managing director, Nigel Shepherd said that the unit's three operating modes — C128, C64 and CP/M — give it the ability to meet virtually any user requirement.

In the C128 mode users are provided with a powerful version of BASIC that has more than 140 commands, statements and functions, while the CP/M mode gives users access to hundreds of



existing programs in the areas of business and education.

The Commodore 128 has a 92-key typewriter keyboard with a

14-key numeric pad for fast, accurate number crunching. It includes eight programmable function keys, six individual cursor

keys for exceptional graphics and text manipulation, and a 'help' key that lists programming errors in reverse field.

Enhanced CP/M on Apple IIc

Thinking Systems has announced the release of the IIc CP/M module with CP/M plus operating system fully configured for the Apple IIc, licensed from Digital Research.

CP/M PLUS is an advanced operating system for 8-bit micros. It features bank switched RAM allowing use of the whole 128K of RAM in the Apple IIc. It is fully compatible

with CP/M 2.2 and provides additional features such as BDOS error trapping, BDOS disk free space functions, BDOS program chaining, RSX modules, LRU (least recently used) sector buffering, data display or directory stamping, and a HELP system.

The IIc implementation also includes several unique features such as the use of the mouse di-

rectly on the text screen 'invisible' print spooler and a selectable keystroke buffer, as well as supporting the normal printer, disk drive and modem ports.

To complement this product there is also available a CP/M Programmers Pack containing a full set of programming utilities including MAC and RMAC (macro assemblers), SID (symbolic debugger), LINK, LIB,

SAVE, HEXCOM, ED, DUMP and XREF programs with a full Digital Research reference manual.

A 12 months full warranty is offered with this new IIc CP/M module.

For further information contact Thinking Systems, 29 Belmore St, Surry Hills, NSW 2010. (02)211-0944.

Artificial creativity

Designing a machine to catch the nuances of everyday language and the creative process of common sense thought has absorbed researchers in philosophy, linguistics, psychology and, of course, engineering.

According to a recent report from the US nine faculty members of the School of Engineering and Applied Science at UCLA are involved in aspects of artificial intelligence ranging from automated factories to pattern recognition.

Professor Michael Dyer has

described their work into AI as 'knowledge engineering' or 'applied epistemology.'

"AI . . . is the subfield of computer science which explicitly takes upon itself the task of discovering the fundamental building blocks of thought, creativity, imagination and language — those elements of the mind which make human beings intelligent," he said.

Once these processes are isolated and understood, the drive will be to create computer programs which imitate the mind.

Thus much energy is expended in cracking this last major mystery of life on Earth and cancelling the dichotomy between the mental and the physical.

But modelling a machine even to recognise speech is a daunting task requiring huge memory and tiny vocabularies, and so far no existing machine can hope to match ordinary common sense functions.

AI researchers are working on both hardware and software, from the development of sophisticated fifth generation robots/

computers to expert systems and cognitive modelling. Successful expert systems have been developed for chess playing, electronic troubleshooting etc, but cognitive modelling which aims to copy perceptual, inferential and creative processes is proving the hard nut to crack. In one project called 'MUSE', Dyer and colleagues are attempting to model the process of daydreaming, while another 'MINSTREL' project seeks to program the art of story-telling.

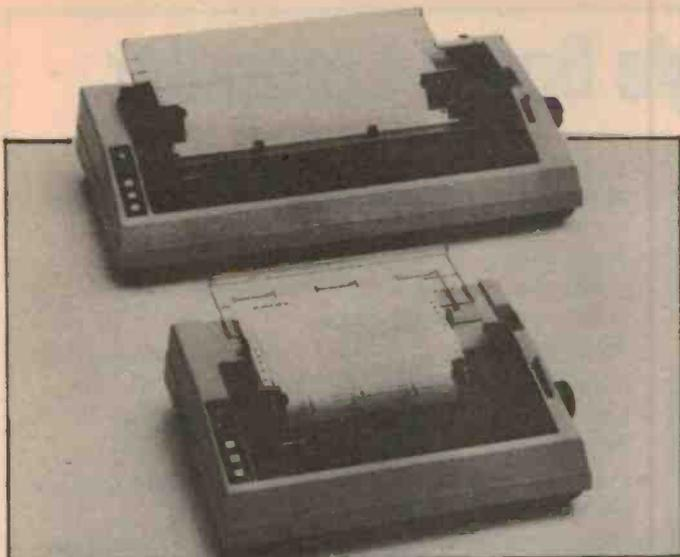

PC printers have two command sets

The 80-column FACIT 4513 and 132-column FACIT 4514 matrix printers include both IBM/EPSON and EPSON FX command sets, making the units compatible with a variety of computers ranging from IBM-PCs to UNIX supermicros.

Print qualities from NLQ at 35 cps to high-speed draft at 160 cps can be easily selected by the operator via a switch on the control panel. A choice of 10, 12 or 17 characters per inch is available as well as proportional printing.

According to EAI-Electronic

Associates, the Australian distributors for FACIT, all standard features of the command sets are handled including multi-resolution pin-graphics, semi-graphics, italics, underline and downline loading. Both parallel and serial interfaces are provided as standard, and the printers can be equipped with low-cost FACIT 5011 and 5012 cut-sheet feeders.

For further information contact EAI-Electronic Associates, 4/2 George St, Artarmon, NSW 2064. (02)427-3322.

Software development centre

Hewlett-Packard has launched a multi-million dollar software centre in Ringwood, Victoria.

The centre, employing 40 people, will have an annual budget of around \$2 million a year to manufacture products for both the local and export markets. Among its first products is a new software package which it is hoped will boost the productivity of Australia's 25,000 small manufacturers. Details of this product have not yet been released, though it is expected to be on the market by the end of the year.

The new centre is also releasing a sophisticated fourth-generation language designed to dramatically improve programmer productivity. Initially de-

veloped by local software house BBJ, and substantially enhanced by HP, it allows business applications to be developed up to 10 times faster than existing languages.

In opening the new HP centre, Victorian Minister for Industry, Technology and Resources, Mr Fordham, said that according to the Ferris Report on national marketing strategy the local software industry was expected to double the number of employment opportunities in the high-tech area over the next five years. An important part of that growth will come from the creation of products for the export market through facilities such as this new software centre.

BRIEFS

Sanyo PC compatibles

Sanyo claims its new MBC 670, MBC 770 and MBC 880 will be the lowest priced IBM compatibles in Australia that offer the necessary 256K RAM for compatibility as standard, equipped with standard power supply to support hard disk expansion without modification. For further information contact Sanyo Office Machines, 5-9 Harbourview Cr, Milsons Pt, NSW 2061. (02) 929-4644.

Nashua disks

Nashua has released three new diskettes for higher recording density. One is the 5¼" 1.6 Mbyte diskette used on the IBM-AT. The other two are the 3½" single and double sided diskettes for use on Apple McIntosh, Hewlett-Packard, Data General, Sony and others. All diskettes are available at the Nashua disks direct sales centres in each capital city in Australia and New Zealand.

Smart switch box for RS232

The SSB 1000 is an intelligent device to switch computers and peripherals. Inbuilt logic electronically reads the data transfer configuration of the computer or peripheral RS232 port and matches its connection to the needs of another RS232 port. For further information contact Pro-Log (Australia), 69 Canterbury Rd, East Camberwell, Vic 3126. (03)836-3533.

Toshiba computer in DSE

Dick Smith Electronics is to market the Toshiba T 1100, an IBM compatible lap computer throughout Australia. This software and T 1100 package is claimed to be a world's first release. The machine has 256K RAM and an integrated 720K, 3.5 inch floppy disk. It will run for up to 8 hours under rechargeable battery power.

For further information contact Dick Smith Electronics stores throughout Australia.

Texas Instruments' Pro-Lite

Pro-Lite, Texas Instruments' powerful briefcase-sized personal computer, is now available throughout Australia. It features a 12-inch liquid crystal display that shows 80 columns by 25 lines and up to 768K bytes of RAM. Its central processing unit consists of a 16-bit 80C88 microprocessor, with an 80C87 numeric co-processor available as an option. Pro-Lite can exchange data files with other TI computers and the IBM-PC. For further information contact Texas Instruments, 6-10 Talavera Rd, North Ryde, NSW 2113. (02)887-1122.

Data meter for RS232

The Smart Data Meter 931 is a low cost unit giving information on RS232 data transmission settings. Testing DCE and DTE devices, it both generates test patterns and receives data transmissions to give read-out of baud rate, word length, parity, stop bits and more.

An easy single button operation allows selection from such menu options as Read, Parame-

ter Scan, Parameter Selection and Print.

The SDM 931 is self contained including a low power CMOS CPU running from a 9 V replaceable battery. It measures 19 cm x 10 cm x 3 cm and weighs approximately 284 g.

For further information contact Pro-Log (Australia) Pty Ltd, 69 Canterbury Rd, East Camberwell, Vic 3126. (03)836-3533.

Tell them you read it in ETI

ECS-186 80186 Single Board Computer

STOP PRESS!!
ECS 286 IS NOW AVAILABLE
4 times faster than IBM AT
and fully PC/XT compatible.

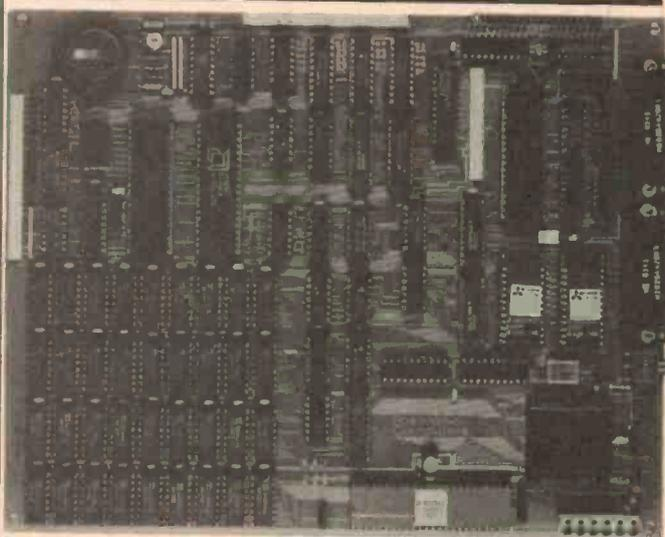

CONFIGURED SYSTEMS

Positronic Computers can supply single-user computer systems in attractive desk top enclosures. All can be expanded to powerful multi-user graphics workstations or networked business computers with the graphics and ARCNET interface cards.

SYSTEM 20

ECS186-10MHz processor
 256k bytes memory
 Two 1.6 mByte floppy discs
 PC/M operating system **\$2495.00**

SYSTEM 30

ECS186-10MHz processor
 256k bytes memory
 1.6 mByte floppy disc
 20 mByte Winchester disc
 PC/M operating system **\$3595.00**

SYSTEM 33

ECS186-10MHz processor
 1 mByte memory
 1.6 mByte floppy disc
 20 mByte Winchester Disc
 PC/M operating system **\$5615.00**

Plus many other drive/memory combinations.



ECLIPSE COMPUTER SYSTEMS
 Designed and manufactured in Australia.

- 80186-1 (10MHz) Central Processor Compatible with 8088/8086 (As used in the IBM-PC) but with up to **Eight** times the performance.
- 256k, 512k or 1mByte of on-card memory with parity checking for maximum reliability. Operates at 10MHz with **NO** wait-states.
- Two full-duplex serial ports with software selectable baud rates from 50 to 38400 baud.
- Complete Centronics 101 compatible printer interface.
- Double density 8", 5¼" or 3½" floppy disc controller. Software selectable for all disc formats.
- Digital phase-locked loop data separator requiring no adjustment.
- SASI hard disc/tape unit interface with DMA transfer to and from controller.
- CMOS battery backed calendar clock with on-card replaceable Lithium battery.
- Operating system bootstrap ROMs.
- PC/M-86 operating system Included **FREE** with kit or assembled and tested card.
- Compact 8"×10" cards fit neatly beside 8" floppy disc drive.

NEW PRODUCTS

- Graphics/terminal card features 512×512 pixel graphics. Keyboard interface for IBM-PC compatible keyboard. Supports:
 - Monochrome (with highlight).
 - 16 colour TTL monitor.
 - Colour palette allowing 16 colours from 4096 colours.
 - High speed vector drawing processor.
 - Uses standard 625 line monitors.
- ARCNET interface for networked multi-user systems when running TurboDOS 1.4. Allows for up to 250 users in network.

ECS186 Prices

ECS186 Kit	
All parts and instructions	\$995.00
ECS186 Assembled and tested	\$1250.00
TurboDOS 1.4	
Single-user print spooling system	\$395.00
PC/M-86	
(Included with ECS186 except mini-kit)	\$30.00

All prices +20% sales tax if applicable.

542 Riversdale Road Camberwell 3124 (03) 813 3447

Emphasised Type

F. Connell, Wodonga, Vic 3690

This is a machine code program loaded from BASIC which produces an emphasised typeface from the character set in PCG.

Points to note:

(1) The program is embedded in the REM statement in line number 00001, so that line MUST be typed just as in the listing, and must remain as the first line of the program.

(2) After typing in the program, and running it, all except the first two lines can be deleted, and then saved to tape.

(3) Because the PCG characters are used for the new typeface, programs with calls to HIRES, LORES, or UNDERLINE will erase the new data... but it is still very nice to use in any text-based programs.

Can readers help:

(1) Is there some way to print PCG characters to the screen using Word-Bee? I'd love to be able to use this typeface for my writing!!

(2) Is there a program around that will allow me to save to tape faster than 1200 baud? I've never had any problems at this speed, and I reckon 2400 shouldn't be a problem.

```
00001 rem1234567890123456789
00002 pcg: list
00003 forf=2309to2327
00004 readD: pokeT, D: nextT
00005 ifpeek(64000)<>0: U=usr(2309): rem This line calls the routine
00006 end
00007 data 33,0,250,1,240,5,126,47,87,23,178
00008 data 119,35,11,120,177,32,244,201
```

Topsyturvy

G. Heathcote, Ingleburn, NSW 2565

This is a short program that turns all the letters and graphic symbols of the Microbee upside down. It could be used in writing titles for programs or anything else you choose.

```
00100 DIMZ0(16):CLS
00110 FORA=63488TO6535STEP16
00120 FORX=0TO15
00130 POKEA+X,255-PEEK(A+X):Z0(X)=FLT(PEEK(A+X)):NEXTX
00140 T=15:FORY=0TO15:POKEA+Y,INT(Z0(T)):T=T-1:NEXTY
00150 NEXTA
00160 FORA=128TO256:PRINTCHR(A) " ";NEXTA
```

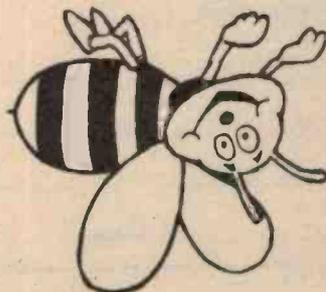

Eclipse Predictions

Steven Saunders, Gymea NSW 2227

This program can be used to predict the date and time of both solar and lunar eclipses. When run, it will prompt for the type of prediction required (solar or lunar) and then ask for a starting year from which to search for all subsequent eclipses.

How does the program work? Every month there is the possibility of a solar and a lunar eclipse. However, most of the time the two don't fall in line because the moon passes either above or below the earth-sun line. This pro-

gram tests each of these possible eclipses to see if the geometry of the earth, moon and sun are such that an eclipse will occur.

When an eclipse is found, calculations are made to determine the type of eclipse and the time of mid-eclipse. For lunar eclipses, time of entry into the umbra and penumbra (region of totality and region of the partial phase respectively) are also calculated. Each predicted time is accurate to within a few minutes.

```
00100 REM *** LUNAR - SOLAR ECLIPSE PREDICTION PROGRAM ***
00110 REM S. SAUNDERS....1982
00120 REM
00130 CLS
00140 CURS 10 :UNDERLINE
00150 PRINT "SOLAR - LUNAR ECLIPSE PREDICTION PROGRAM"
00160 NORMAL :PRINT
00170 PRINT "Do you require an explanation ?"
00180 GOSUB 2100
00190 IF A0$="N" OR A0$="n" THEN 480
00200 PRINT "With this Program it is Possible to Predict the dates and"
00210 PRINT "times of both LUNAR and SOLAR eclipses to an accuracy of a"
00220 PRINT "few minutes. The following terms are used in the Predictions"
00230 PRINT
00240 PRINT "LUNAR ECLIPSE...The moon enters the shadow cast by the earth."
00250 PRINT TAB(10)*1. TOTAL.....The moon enters the main shadow cone"
00260 PRINT TAB(13)*"or UMBRA."
00270 PRINT TAB(10)*2. PARTIAL.....The moon only skims the umbra"
00280 PRINT TAB(10)*3. PENUMBRAL...The moon only enters the outer."
00290 PRINT TAB(13)*"fainter shadow cone or PENUMBRA."
00300 PRINT
00310 PRINT "PRESS A KEY WHEN YOUR READY"
00320 GOSUB 2100
00330 CLS
00340 PRINT "SOLAR ECLIPSE.....When the moon passes in front of the sun"
00350 PRINT
00360 PRINT TAB(10)*1. TOTAL.....If the main umbra reaches the earth"
00370 PRINT TAB(13)*"and hence completely covers the sun."
00380 PRINT TAB(10)*2. PARTIAL.....If only a fraction of the sun is"
00390 PRINT TAB(13)*"covered by the moon."
00400 PRINT TAB(10)*3. ANNULAR....If the moon passes directly in"
00410 PRINT TAB(13)*"front of the sun but is too small to cover the sun."
00420 PRINT TAB(13)*"Only an annulus of the sun is seen."
00430 PRINT
00440 PRINT "MAGNITUDE is the amount of the sun covered by the body."
00450 CURS 10:14
00460 PRINT "PRESS A KEY WHEN YOUR READY"
00470 GOSUB 2100
00480 SD (14)
00490 CLS
00500 P0=3.1415926536*180
00510 FN0=COS(#P0)
00520 FN1=SIN(#P0)
00530 PRINT "Do you want predictions for SOLAR or LUNAR eclipses"
00540 PRINT
00550 A0$=KEY IF A0$="" THEN 350
00560 IF A0$="S" OR A0$="s" THEN LET M=1 PRINT "SOLAR" GOTO 590
00570 IF A0$="L" OR A0$="l" THEN LET M=0 PRINT "LUNAR" GOTO 590
00580 GOTO 550
00590 INPUT "Enter year to start search from (yyyy) " :Y0
00600 PRINT LA25 32J
00610 K0=(Y0-1900)*12.3685
00620 K=INT(K0-FRAC(T(K0)))
00630 IF M=1 THEN LET K0=FLT(K)
00640 IF M=0 THEN LET K0=FLT(K)*.5
00650 CURS 20:8
00660 PRINT "CALCULATING NOW" :LA15 8J:
00670 T0=K0/1236.85
00680 T2=T0*T0
00690 T3=T0*T2
00700 REM
00710 REM ..... CALC MOON'S ARGUMENT OF LATITUDE .....
00720 REM
00730 F0=21.2964+390.67050646*Y0-.0016528*T2-.00000239*T3
00740 GOSUB [F0] 2070
00750 F0=G5
00760 IF ABS(FN1(F0))>.36 THEN LET K0=K0+1 GOTO 670
00770 J0=2415020.7593+29.53058868*K0+.0001178*T2-.00000155*T3+.00033*FN1(166.5
9+132.87*T0-.009173*T2)
00780 M0=359.2242+29.10535608*K0-.0000333*T2-.00000347*T3
00790 GOSUB [M0] 2070
00800 M0=G5
00810 M1=306.0253+385.81691606*K0+.0107306*T2+.00001236*T3
00820 GOSUB [M1] 2070
00830 M1=G5
00840 REM
00850 REM ..... CALC TIME OF MAXIMUM ECLIPSE .....
00860 REM
```

```

00870 J0=J0+(.1734-.000393170)*FNI(M0)*.0021*FNI(2*M0)-.4066*FNI(M1)*.0161*FNI(2
*M1)-.0051*FNI(M0*M1)-.0074*FNI(M0-M1)-.0104*FNI(2*F0)
00880 S0=5.1959-.0040*FNO(M0)*.002*FNO(2*M0)-.3283*FNO(M1)-.006*FNO(M0*M1)*.004
1*FNO(M0-M1)
00890 C0=.2070*FNI(M0)*.0024*FNI(2*M0)-.039*FNI(M1)*.0115*FNI(2*M1)-.0073*FNI(M0
*M1)-.0067*FNI(M0-M1)*.0117*FNI(2*F0)
00900 REM
00910 REM ....CALC MIN DISTANCE FROM SHADOW TO CENTER OF PLANET ....
00920 REM
00930 Y0=S0*FNI(F0)+C0*FNO(F0)
00940 U0=.0059+.0046*FNO(M0)-.0182*FNO(M1)*.0004*FNO(2*M1)-.0005*FNO(M0*M1)
00950 F7=FRACT(J0+.5)
00960 Z0=J0+.5-F7
00970 IF Z0<2299161 THEN LET A0=Z0 GOTO 1010
00980 I0=(Z0-1867216.25)/36524.25
00990 W0=I0-FRACT(I0)
01000 A0=Z0+1+W0*(W0/4-FRACT(W0/4))
01010 B0=A0+1524
01020 I0=(B0-122.1)/365.25
01030 C7=I0-FRACT(I0)
01040 I0=C7*365.25
01050 D7=I0-FRACT(I0)
01060 I0=(B0-D7)/30.6801
01070 E7=I0-FRACT(I0)
01080 I0=E7*30.6801
01090 M7=B0-D7-I0+FRACT(I0)+F7
01100 IF E7<13.5 THEN LET L=INT(E7-1)
01110 IF E7>13.5 THEN LET L=INT(E7-13)
01120 IF L>2 THEN LET Y=INT(C7)-4716 ELSE LET Y=INT(C7)-4715
01130 IF M=0 THEN 1340
01140 REM
01150 REM ..... DETERMINE TYPE OF SOLAR ECLIPSE .....
01160 REM
01170 Y6=ABS(Y0)
01180 IF Y6>1.5432+U0 THEN LET K0=Y0+1 GOTO 670
01190 IF Y6>.9972 AND Y6<1.026 THEN LET S=2 GOTO 1220
01200 IF Y6>.9972 AND Y6<1.5432 THEN LET S=1 GOTO 1220
01210 S=0
01220 IF S<0 THEN 1300
01230 IF U0<0 THEN LET S=3 GOTO 1930
01240 IF U0>.0047 THEN LET S=4 GOTO 1930
01250 I3=ATAN(Y0/SOR(1-Y0*Y0))
01260 I4=.00464*COS(I3)
01270 IF I4>U0 THEN LET S=5 GOTO 1850
01280 S=4
01290 GOTO 1930
01300 M5=(1.5432+U0-Y6)/(.546+2*U0)
01310 GOTO 1930
01320 REM
01330 REM ..... DETERMINE EXTENT OF LUNAR ECLIPSE .....
01340 M5=(1.0129-U0-ABS(Y0))/.5450
01350 IF M5<0 THEN 1450
01360 P=1
01370 P1=1.0129-U0
01380 T0=.4679-U0
01390 N0=.5450*FNO(M1)*0.04
01400 P3=SOR(P1*P1-Y0*Y0)*60/N0
01410 P4=T0*T0-Y0*Y0
01420 IF P4<0 THEN LET P4=0
01430 P4=SOR(P4)*60/N0
01440 GOTO 1490
01450 P=0
01460 M5=(1.5572+U0-ABS(Y0))/.545
01470 IF M5<0 THEN 1810
01480 GOTO 1490
01490 CLS
01500 CURS 25 UNDERLINE
01510 PRINT "LUNAR ECLIPSE"
01520 PRINT
01530 IF P=0 THEN PRINT "PENUMBRAL"
01540 IF P=1 AND M5<1 THEN PRINT "PARTIAL"
01550 IF P=1 AND M5>1 THEN PRINT "TOTAL"
01560 PRINT " ECLIPSE OF THE MOON"
01570 IF Y0<0 THEN PRINT " (In Southern Hemisphere)" ELSE PRINT " (In No
thern Hemisphere)"
01580 NORMAL CURS 1,5
01590 PRINT "DATE.....INT(M7)-"L"-PY " (For mid eclipse)"
01600 PRINT
01610 PRINT TAB(25) "Hr Min" TAB(50) "Hr Min"
01620 T5=FRACT(M7)
01630 IF P=0 THEN 1720
01640 GOSUB [-P3] 2000
01650 PRINT "MOON ENTERS UMBRA" TAB(25)U" "Y;
01660 GOSUB [P3] 2000
01670 PRINT TAB(30) "LEAVES" TAB(50)U" "Y
01680 GOSUB [-P4] 2000
01690 PRINT "TOTAL ECLIPSE BEGINS" TAB(25)U" "Y;
01700 GOSUB [P4] 2000
01710 PRINT TAB(30) "ENDS" TAB(50)U" "Y
01720 GOSUB [0] 2000
01730 PRINT "MIDDLE OF ECLIPSE" TAB(25)U" "Y
01740 PRINT TAB(20) "UT" IF M=0 THEN PRINT TAB(53) "UT"
01750 PRINT
01760 IF M=1 AND (S=0 OR S=3 OR S=4 OR S=5) THEN 1780
01770 PRINT "MAGNITUDE OF ECLIPSE " (F7.4 M3)
01780 IF S=2 THEN PRINT "PRINT "ECLIPSE NOT CENTRAL BUT UMBRA MAY TOUCH THE POLE
S"
01790 CURS 15,14 PRINT "Press any key for the next event"

```

```

01800 GOSUB 2100
01810 K0=K0+1
01820 GOTO 660
01830 CLS
01840 UNDERLINE
01850 CURS 25,2 PRINT "SOLAR ECLIPSE"
01860 PRINT
01870 IF S=1 OR S=2 THEN PRINT "PARTIAL";
01880 IF S=4 THEN PRINT "ANNULAR";
01890 IF S=3 THEN PRINT "TOTAL";
01900 IF S=5 THEN PRINT "ANNULAR-TOTAL";
01910 PRINT " ECLIPSE OF THE SUN";
01920 IF Y0<0 THEN PRINT " (In Southern Hemisphere)" ELSE PRINT " (In Nort
hern Hemisphere)"
01930 NORMAL
01940 PRINT
01950 PRINT "DATE" TAB(20) INT(M7)-"L"-PY " (For mid eclipse)"
01960 PRINT
01970 T5=FRACT(M7)
01980 PRINT TAB(25) "Hr Min"
01990 GOTO 1720
02000 VAR (I6)
02010 M3=1440*T5+16
02020 U=INT(M3/60)
02030 Y=INT(M3)-60*U
02040 IF U<0 THEN LET U=U+24
02050 IF U>23 THEN LET U=U-24
02060 RETURN
02070 VAR (G5)
02080 G5=FRACT(G5/360)*360
02090 RETURN
02100 A00=KEY$ IF A00="" THEN 2100
02110 RETURN

```

CONTRIBUTORS PLEASE NOTE

All contributions to this column should be accompanied by a listing of the program from a printer. Hand written or typed listings are not acceptable.

There are two reasons for this. The first is that a listing from your computer gives us some guarantee that you have got the listing correct.

Secondly, if you present us with a neat final copy of your program we can use photographic techniques to reproduce it in the magazine, without risk of errors.

However, if you present us with a scrawl done on the back of someone's old fag packet it needs to be manually typed twice here, with consequent increase in labour on our part and increase in the probability of errors.

Contributors will be paid \$20 for each item published in this column. Submissions must be original programs which have not been previously published. You may send as many programs as you wish with the accompanying declaration.

"I agree to the above terms and grant *Electronics Today International* all rights to publish my program in *ETI Magazine* or other publications produced by it. I declare that the attached program is my own original material, that it has not previously been published and that its publication does not violate any other copyright."

* Breach of copyright is now a criminal offence.

Name

Signature Date

Address

Postcode

**NEW
LOW PRICE!**

A real computer for only \$69!

AQUARIUS™

The REAL computer that starts from under \$100! You'd love to learn about computers? But thought all you could buy for your money were a few boring games. Now, we are the EXCLUSIVE Australian distributors of the new Aquarius. Not the "Claytons" computer but the perfect beginner's computer which gives you the opportunity to see what a real computer does.

Learn how to RUN YOUR OWN PROGRAMS in the Basic language! PLAY GAMES! Organise your HOUSEHOLD FILES! And much much more!

Simply connect the Aquarius to any colour TV and it's ready to teach and entertain the whole family. There's something for everyone. And what's more, you won't outgrow the Aquarius! As you need to

learn more, the Aquarius offers a huge range of add-ons that will take you into the world of electronic wizardry once offered only by the BIG ones.

With a full moving-key keyboard Aquarius is truly EASY to USE. Microsoft BASIC computer language is built right in! The easy-to-read manual and simplified instruction cards make learning a snap.

CREATE your own VISUAL EFFECTS with 16 colours and 256 built-in characters or design your own sound effects! Once you start to expand your Aquarius with the huge software and hardware range you'll find endless uses and possibilities for your system. With it's own mini expander, data recorder, memory expansion cartridges and thermal printer you'll soon wonder what the Great

Computer Secret was all about!

FANTASTIC SOFTWARE RANGE

With more than two dozen fantastic games and educational programs available now and many being developed to add to the range shortly, there's just no end to the versatility of Aquarius. Software cartridges just plug into your Aquarius and you're ready for work or play. All software programs are available separately so you can purchase only those which interest you.

AQUARIUS with built in 2K memory (expandable to 34K) and its long list of expansion units and software is the REAL computer for the price of a TOY!

1. MINI EXPANDER

Adds versatility to your AQUARIUS. Game playing is easier and more exciting with 2 detachable hand controllers and additional sound channels. Also has 2 cartridge ports so you can plug in your expanded memory cartridge into one even while you're using software in the other.

Cat X-6005 **\$69**

2. DATA RECORDER

Save your own program or utilise one of the many great software programs available on cassette with this great value unit.

Cat X-6010 **\$49**

3. MEMORY EXPANSION CARTRIDGES

16K or 32K memory cartridges give you far greater flexibility by giving your computer a much larger memory. For more advanced programming.

16K Cartridge Cat X-6015 **\$69**

32K Cartridge Cat X-6020 **\$129**

4. THERMAL PRINTER

Ideal for documenting programs, keeping records or printing charts and records. You'll probably never again see one at this price!

Cat X-6025 **\$129**

Paper roll to suit. Cat X-6026 **\$350**

Aquarius Colour Computer

Cat X-6000

**WAS \$99
NOW
ONLY**

\$69

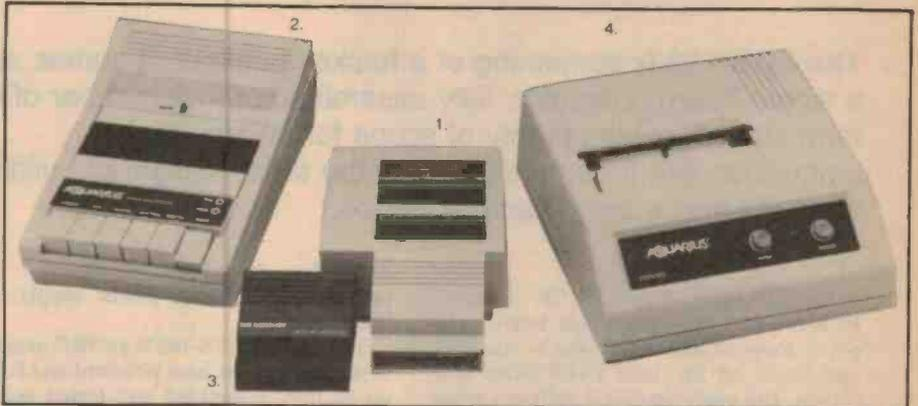

Dick Smith Electronics Pty Ltd

COMPUTERSTOP



Your one stop computer shop at your nearest Dick Smith Electronics centre.

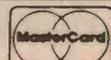

WELL STAGED PERFORMANCE

— Eclipse Computer ECS-186

Geoff Nicholls

The ECS-186 is something of a hacker's delight. It comes as a single board computer, fully assembled or in a number of kit form stages leaving plenty of scope for any level of enthusiast. But it offers more than the sheer delight of building it up; it's also a very practical device.

THE ECLIPSE COMPUTER System's ECS-186 is a powerful single board computer designed and developed in Australia and based on the Intel iAPX-80186 processor. The manufacturer is selling a range of products based on the ECS-186 starting with the bare pc board all the way up to a complete 20 megabyte hard disk system. For the review, Eclipse sent me a twin 5¼ inch floppy system with a 10 MHz '80186 and 1 megabyte of RAM which was mounted in a neat plastic case together with a power supply.

For the purpose of the review, Eclipse also supplied a Qume serial terminal for the user console.

The single board computer (SBC) has always been popular with hobbyists who sacrifice the convenience of a plug-in-and-go personal computer for the extra hardware performance per dollar offered. The typical SBC has plenty of on-board memory, a floppy disk controller, a few RS232 ports, a printer port and the boot ROMs for the operating system. Most use a serial terminal for the operator console, although some provide on-board CRT controllers and direct keyboard ports. You have to add a power supply, the disk drive(s) and the connectors and cables necessary to hook everything up (plus a serial terminal if required), all of which tends to make the usable system cost more than the advertisements would generally indicate, however many people opting for the SBC approach will be hackers

prepared to build a power supply, etc, themselves.

The Eclipse ECS-186 is an SBC available in stages from the bare pc board and ROMs up to fully assembled and tested systems mounted in a case and ready to switch on. ETI readers should be interested in the kit version. You get a kit of all parts and instructions at a saving of \$250 over the assembled and tested board.

The most popular SBC processor has been the Z-80 due to its ability to run CP/M and the huge number of CP/M application programs. Within the last few years a new contender for CPU in the SBC has emerged — the Intel iAPX-80186. I have noticed several new boards from different manufacturers using the '80186 in both SBCs and S100 and STD bus cards. In seeing how much system hardware the '80186 replaces it's no wonder it is becoming popular.

The 8086 et al

The two workhorses of the Intel stable before the '186 and '286 were the 8086 and 8088 CPUs. Both chips differ from earlier microprocessors in that they contain two separate processing units called the Execution Unit (EU) and the Bus Interface Unit (BIU). The EU is identical in the '86 and '88 and but the BIU of the '88 operates on 8-bit wide data while the '86 BIU can handle 16-bits at once. The BIU 'feeds' the EU with program instructions and also transfers data in and out of the CPU, while the EU

does the actual program execution — manipulating registers and maintaining CPU status and control flags. The advantage of this architecture is that the EU in most cases does not have to wait for instructions to be fetched, the BIU maintains a queue of the next few logical instructions and can fetch instructions at the same time as the EU is executing earlier instructions. This improves throughput over the earlier CPU architectures at the same clock speeds. The 8086 will run faster than the 8088 because of the 16-bit data bus to the external world.

There are two other processors in the 8086 family that are designed to run as co-processors in an 8086 or 8088 system. These are the 8089 Input/Output Processor (IOP) and the 8087 Numeric Processor eXtension (NPX). For more information on these products and the 8086 family as a whole I suggest you contact Intel directly.

The iAPX 80186

The ECS-186 uses the Intel iAPX-80186 CPU which is a particularly powerful member of the Intel range. The '80186 can run 8086 or 8088 software directly, so the large library of programs written for them may be used. Whether or not they will run depends on the operating system environment, discussed later.

The '80186 also has several 'extras' on the chip that would normally require more LSI packages and consequently more pc board area to duplicate with a lesser processor. These include counter timer clock (CTC) channels, two direct memory access (DMA) channels, several priority interrupt channels plus on-board chip select decoding. It even has an on-board crystal oscillator and clock generator, thus eliminating the 8284 chip prevalent in 8086 based designs.

By the way, all the 'internal peripherals' in the '80186 have been used in the ECS-186

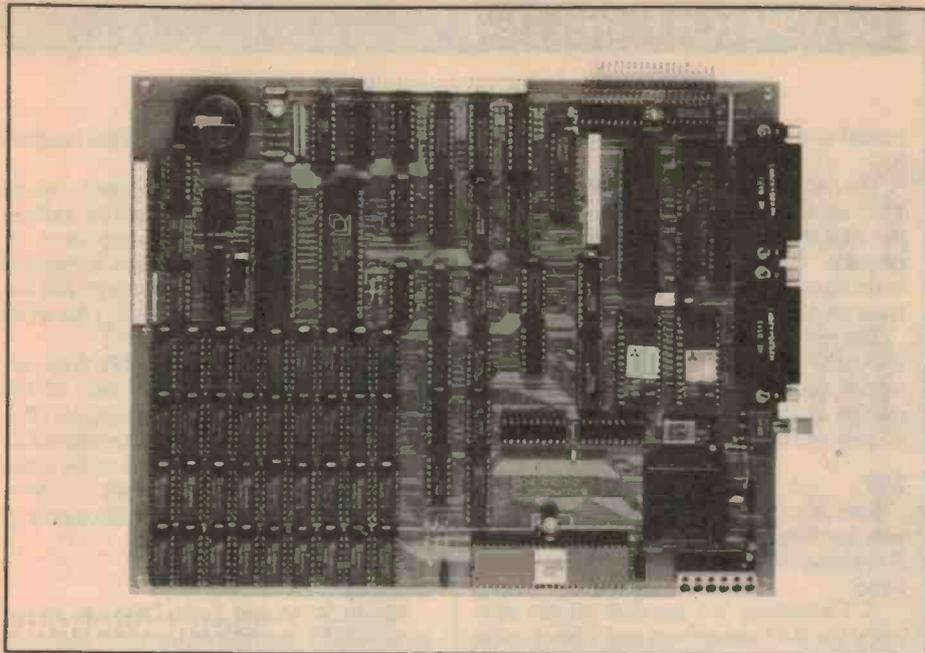

SBC too, so programmers should be wary of crashing the system by overlooking the effects of using them.

The allocation list of the ECS-186's internal peripherals makes interesting reading, demonstrating just how much the '80186 does in practice:

Counter timer 0	memory refresh
Counter timer 1	real-time clock for O/S
Counter timer 2	floppy disk delay timer
DMA channel 0	SASI hard disk transfer request
DMA channel 1	floppy disk data request
Interrupt 0	SASI COM byte interrupt
Interrupt 1	floppy disk attention
Interrupt 2	serial communications controller interrupt
Interrupt 3	expansion interface interrupt
Non-maskable interrupt	memory parity error
HOLD/HLDA	memory refresh
PCS0	serial communications controller
PCS1	I/O expansion bus
PCS2	8255 PPI
PCS3	floppy disk controller
PCS4	floppy disk data acknowledge
PCS5	SASI/Centronics interface
Upper chip select	selects boot ROMs
Note: PCS = peripheral chip select	

The iAPX-80286

The big daddy of the Intel 8086 family is the '80286 which offers performance that was previously only available from mini-computers. Its forte is the on-board memory management that handles most of the work in running a multiuser, multitasking system. Each task can run in any of four privilege levels to isolate users from the operating system and from each other. The addressing scheme gives each task up to a gigabyte (1,000,000,000 bytes) of virtual memory, although the physical address space is only (!) 16 megabytes. Separate data and address lines double the bus bandwidth over the multiplexed bus of the 8086/'80186, at the expense of extra pins.

With all this power why wasn't an '80286 used in the ECS-186? I asked Peter Nunn (who designed the ECS-186 with Philip Grasso) that question. He replied that the primary design goal was to fit as many features as possible onto a low-cost double-sided pc board that measured 200 mm by 250 mm, the same area as an 8" disk drive. To replace the '186 with a '286 would require a DMA controller, an interrupt controller and a clock circuit to be added since these internal peripherals of the '186 are not found in the '286 because of all the memory management hardware provided. At the time a decision was made, the '286 cost four times the price of the '186 and would have required a multi-layer pc board, so the latter was chosen for the design that became the ECS-186. I doubt if the intended single user market of the ECS-186 would gain anything from the '286 anyway; I've never needed a multitasking system.

Memory

The '80186 can address up to 1 megabyte of memory and the ECS-186 has space for this much on board, so there is no need

for any off-board memory expansion connectors.

Either 4164 or 41256 dynamic RAMs (DRAMs) may be used by changing a pc board jumper. Two banks of 18 DRAMs each are used, but only one need be populated to operate. The extra DRAM per byte is used for the parity bit — all memory is parity checked. If a parity error is detected a latch is set, illuminating an LED that stays on until a system reset.

The parity error latch is also connected through a jumper to the non-maskable interrupt (NMI) of the '80186, so a parity error results in a jump to the operating system which will try to print a suitable message on the user console. I managed to induce a parity error while running Wordstar by switching on a colour TV connected to the same extension lead as the review computer. (This is a severe test of the power supply filtering that also crashes my Microbee on occasion.) The parity error message came up and I was left in the operating system, all the Wordstar stuff since the last save was lost. The jumper allows the NMI to be disabled, although the LED will still warn of errors. One point about parity checked memory — every location must be written on power up to initialise the parity bits. Also, once an error has been detected the memory must again be rewritten to avoid detecting the same error repeatedly.

The DRAM array is managed by an LSI controller (not inside the '80186 for a change!), a PAL (programmable array logic) device and some LSTTL, which combine to allow operation at 10 MHz without wait states using 150 nanosecond DRAMs. This is essential if the full power of the '80186's pre-fetching architecture is to be realised.

The hard disk interface

The ECS-186 has a 50-way SASI port designed to connect directly to an SASI hard disk controller. You can't attach just any SASI controller however, since the operating system hard disk driver routines required differ from one controller to the next. Eclipse has suitable drivers for these different controllers, but has selected the Western Digital WD1002-SHD unit as the standard. There are several pages of notes for anyone writing a custom driver, including a source code listing of the TurboDOS driver for the WD1002-SHD.

I did not get a chance to try the hard disk out since the review machine did not have one.

Floppy disk controller

The review machine was fitted with two Mitsubishi 4854s which are 5¼" drives with a formatted capacity of 1.2 megabytes each. (Makes your IBM look pretty limp-wristed, eh?)

Eclipse claims to now have 4855 drives with 1.6 megabytes of formatted data and the ability to read standard density minifloppies. I was wary of the reliability of such high density drives, but over the review



Rockwell

65XXX — 68000 SAVE \$\$\$\$

6500 SERIES

R6502P	8.50
R6502AP	9.28
R6503AP	7.24
R6504AP	7.24
R6505AP	7.24
R6507AP	7.24
R6511Q	21.26
R6511AQ	23.28
R6520P	5.19
R6520AP	5.98
R6522P	6.77
R6522AP	7.55
R6532P	9.44
R6532AP	10.39
R6541Q	19.17
R6541AQ	21.09
R6545-1P	9.13
R6545-1AP	10.70
R6545AP	12.27
R6549P	60.58
R6551P	9.91
R6551AP	10.70

CMOS DEVICES

R65C02P1	10.39
R65C02P2	11.80
R65C102P1	10.39
R65C102P2	11.80
R65C21P1	5.82
R65C21P2	6.77
R65C22P1	7.71
R65C24P1	6.61
R65C24P2	7.71
R65C51P1	12.27
R65C51P2	13.53
R65C52P1	22.03
R65C52P2	24.86

HIGH LEVEL LANGUAGE CIRCUITS

R65F11P	32.42
R65F11AP	35.72
R65F12Q	42.33
R65F12AQ	46.58
R65FR1P	97.25
R65RT2P	97.25
R65FR3P	97.25
R65FK2P	10.70

MODEMS

R1212M	358.05
R1212DS	267.51
R2424M	590.22
R2424DS	361.93

DISPLAY

CONTROLLERS

10937P-50	11.02
10951P-50	11.02
10938P	9.44
10939P	9.44
10941P	9.44
10942P	9.44
10943P	9.44

16 BIT 68000

SERIES I.C.'s

R68000C10	69.24
R68000Q10	33.04
R68465P	16.52
R68C552P	27.07
R68561P	58.22
R68802P	61.37

MEMORY I.C.'s

2114	1.35
4116	2.65
4164	1.35
41256	6.67
6116	7.18
6264	20.26
2716	4.81
2732	POA
2764	3.18
27128	5.75

CRYSTALS

32.768 KHz-CMOS Calendar	1.96
1.8432MHz	3.08
2.000MHz	3.08
2.4576MHz	1.96
3.6864MHz	1.96
4.000MHz	1.96
4.9152MHz	2.80
8.000MHz	1.96
12.000MHz	1.96

Qulp Socket
for R6511Q,
R68000Q, R65F12,
Modem I.C. 3.12

PROTOTYPING

CIRCUITS —

Emulators for Mask Programmable I.C.'s	
R6500/1EAB3	69.24
R65/11EB2	62.94
R65/11EAB	69.24
R65/41EAB	69.24

Please include \$6.50 for
packaging and freight

All prices include sales tax

Prices subject to alteration
without notification

**energy
CONTROL**

73 Eric Street, Goodna Q 4300
P.O. Box 6502, Goodna Q 4300
Telephone (07) 288 2455
Telex AA43778 ENECON

EQUIPMENT REVIEW

period of a month they performed faultlessly.

The ubiquitous Western Digital WD-1797 controller chip is used together with the FDC9229 digital data separator to implement the floppy disk controller. The extra signals not provided by the '1797 come from an 8255 PPI.

Jumper blocks are provided to work with 5¼" or 8" drives by using one 50-way connector and reconfiguring the lines as required. If 5¼" drives are used only the last 34 pins of the connector are needed.

I/O

Two asynchronous serial RS232C channels are implemented with a Zilog Z8531. Each channel can run at speeds up to 38,400 baud.

A Centronics 101 parallel printer connects via IDC connectors and ribbon cable directly to the on-board port. Indeed I hooked up my printer with a cable borrowed from the ETI-666 printer sharer and had no trouble printing Wordstar files.

A 40-way IDC header brings out the I/O expansion interface. This is an 8-bit data, 7-bit address bus capable of addressing 128 bytes of external peripherals. One of the '80186's interrupt lines is dedicated to this interface.

Real time clock

One of my tests of 'real' computers is whether they know what day it is! A battery backed CMOS clock calendar on the PC-186 provides date and time for up to five years per lithium battery. It certainly helps when searching file directories to know which is the latest version of a program; TurboDOS does this for you.

Operating systems

These days the hardware is not really as important as the software — most people using computers run commercial application programs. It's certainly no use having the fastest CPU on the block if you have nothing that will run on it.

The review machine came with TurboDOS 1.4 which is a multitasking operating system that looks like an enhanced CP/M. One of the interesting features of TurboDOS is the optional hashed directory structure. A normal directory is searched from one end to the other until the requested entry is found — this minimises directory storage but is not very quick in finding things. In a hashed directory, some part of the file name is used in an algorithm to develop an address that is usually very near to where the file information is stored, thus minimising search time.

An assembler/linker/debugger package is included and TurboDOS also comes with a Z-80 emulator, an MS-DOS 1.1 emulator and an IBM-PC disk copy program — but don't assume that you can run IBM-PC soft-

ware; the ECS-186 is not hardware compatible with the IBM.

The power of TurboDOS will exceed most users' requirements so the Eclipse team has written a CP/M-86 compatible operating system called PC/M. This is supplied free with all assembled systems and kits except the bare board and ROMs. (An extra \$30 will get you a copy, though.)

Why not just supply CP/M-86? Well, according to Peter Nunn, the cost of the licensing arrangements from Digital Research to relatively small manufacturers like Eclipse are so unrealistic that it really made business sense for Eclipse to write its own. The same comments apply to Microsoft in relation to MS-DOS.

Support hardware

The ECS-186 and TurboDOS can access an ARCNET through an interface card supplied by Eclipse. Up to 250 users may be attached to each network.

A 512 x 512 pixel colour graphics/terminal card with 256K of local memory may be used instead of or in conjunction with the serial terminal. An on-board vector drawing processor speeds up the drawing of complex graphics. The card sells for around \$550 plus tax.

Documentation

Considering the amount of work that must have gone into the design and development of all the hardware and software in the ECS-186 I was not expecting too much from the literature. A manual has been prepared that covers the PC/M operating system and the ECS-186 hardware. I have seen some abysmal efforts at documenting computer hardware before, and was pleased to find the ECS-186 hardware information was of a high standard. Each section of the computer is detailed with all jumper options clearly shown, all addressing information, I/O assignments and notes about any aspect that needed further clarification. Complete circuit diagrams and parts lists were included, although I did not see the kit assembly instructions, since the review machine was assembled.

A listing of 20 odd source files for the TurboDOS drivers was provided for those who want to get into the operating system.

Conclusion

The ECS-186 is a well designed and documented single board computer available in several stages of construction. The assembled and tested ECS-186 board is around \$1250 with 128K DRAM. With the price of disk drives falling all the time I think an ETI reader with some hardware experience could put a working disk system together for well under \$2000 plus a serial terminal, even less for the kit version. Recommended!



Be healthier! Live longer!

*With the help of
Prevention Magazine...*

Each month...

ideas, tips, and medically based advice to help improve and maintain the good health of you and your family.

Each month...

PREVENTION Magazine is packed with articles, reports, and regular features... about topics that could affect your health –
☆ Women's health ☆ Men's health ☆ Family health ☆ Infant care ☆ Health through exercise ☆ Health through food ☆ Natural healing ☆ Vitamins ☆ Dental care ☆ Beauty network ☆ Product watch ☆ Health books review ☆ Health for pets...and more!

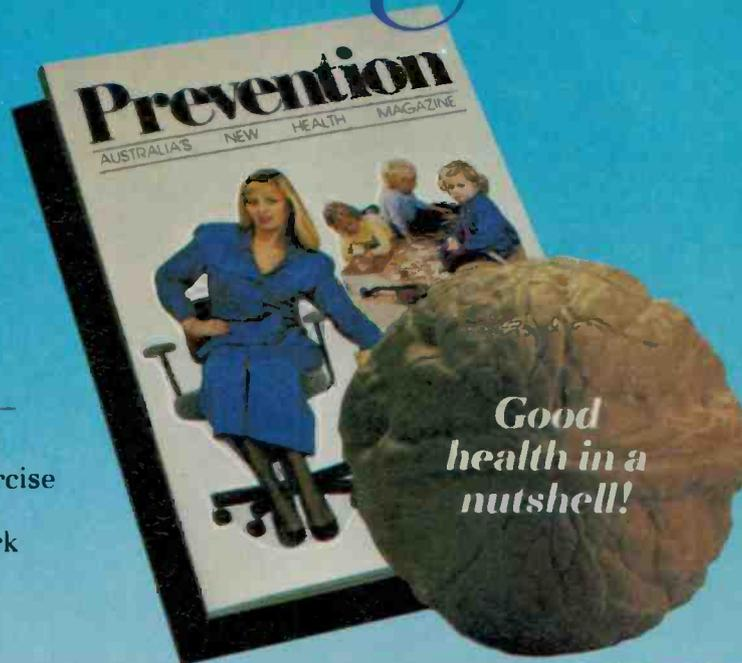

Good health in a nutshell!

Add Prevention Magazine to your regular reading – it could help you be healthier, live longer...there's nothing more important, is there?

**Subscribe now and
SAVE \$3**

Offer valid within Australia until 30/12/85. Please allow up to three weeks for delivery of your first issue.

Yes! Please send me twelve monthly issues of Prevention Magazine at the special introductory price of only \$15.00 instead of the usual \$18.00 (the first two issues are free).

MR/MRS/MISS _____

ADDRESS _____

POSTCODE _____

I enclose payment cheque/money order payable to The Federal Publishing Company Pty. Ltd. Mail to Freepost No. 4, The Federal Publishing Company, P.O. Box 227, Waterloo NSW 2017. No stamp is required if posted in Australia.

Charge to my Bankcard Mastercard American Express

CARD No. _____

Expiry Date

/ /

Signature _____

MAKING T

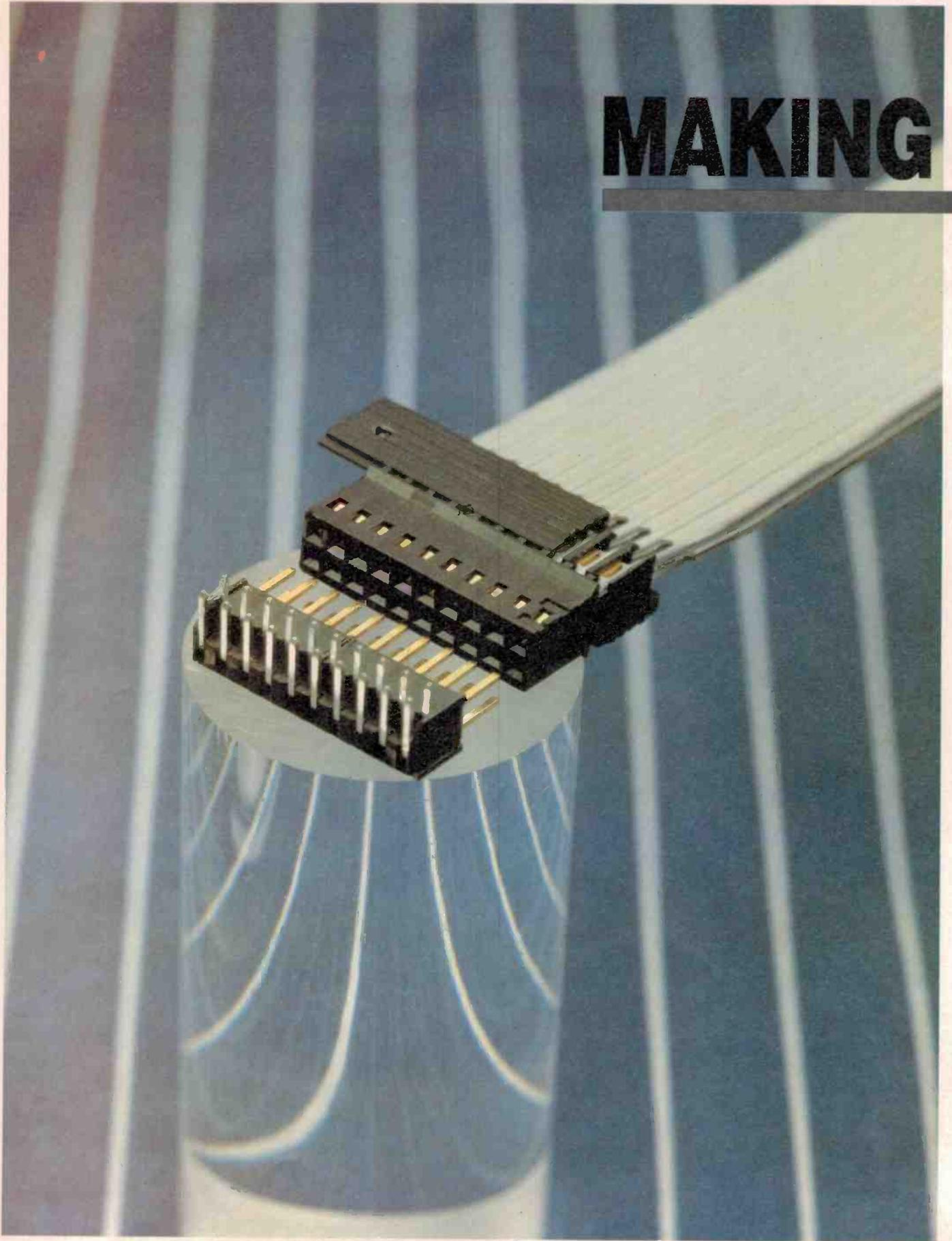

THE RIGHT CONNECTION

Peter Phillips

A STUDY OF passive components, such as that presented in the last two parts of this series would be very incomplete without looking at the means of interconnecting them. Because of the diverse requirements of electronic circuitry and the varied environments encountered, many different types of plugs and sockets (connectors) are employed, allowing an equally wide range of cables to be interconnected. For more practical purposes a few connectors and cables are particularly common and bear taking a close look at.

Wiring

Although the printed circuit board effectively 'wires' all the onboard components together, additional wiring is usually required to interconnect the pc board to peripheral devices such as switches, other pc boards, indicator lights, the power supply, devices being controlled by the circuitry, etc. As well, different types of signals need to use cabling designed for the purpose. A special type of signal wire, usually referred to as 'coax', is commonly used for signal distribution.

Single strand wire

Usually, wiring within an electronic circuit is either power or signal wiring. Power supply wiring often requires the use of a relatively heavy gauge of wire compared to signal wire, and should be appropriately colour coded. Power wiring requirements are determined by the values of voltage and current being distributed. The voltage determines the insulation requirements of the wire, and the current the size of the wire.

Wire sizes are measured in various ways, depending on whether the wire is single or multistranded. Single strand wire can be either winding wire, electrical power wire, or signal wire such as is used for telephony. Winding wire is usually given a gauge, either B&S (Brown & Sharpe, also referred to as the American wire gauge, AWG); SWG (standard wire gauge), or the metric gauge. In general, the larger the SWG or B&S number, the smaller the diameter of

It might seem that there are about as many cables and connectors as there are electronic applications. A little cable knowledge and the right connection can go a long way towards getting the best performance out of your circuit!

the wire, with the metric gauge simply indicating the diameter of the wire in millimetres. One point of confusion is the use of the word 'mil'. This is an imperial unit, and equals one thousandth of an inch. Tables relating the various winding wire sizes, along with resistance per unit length are usually readily available, and a wall chart detailing this information is useful if you are into coil winding.

Electrical power wire is not generally used in electronics except in applications involving electrical power control. In this case the power wiring from the controller to the load would be the responsibility of a licensed electrician, with the electronics being the unit supplying the control signals. In large systems, it will often be the responsibility of the electrician to install the wiring supplying mains power to the electronics as well. As our concern is electronics, a discussion on electrical power wire is not appropriate here.

Telephone wire and bell wire are other types of single strand wire, characterised by plastic insulation rather than an enamel type insulation as used in winding wire. Telephone wire is useful for breadboarding, (or for telephone connections), but is not really useful in most electronic applications due to its susceptibility to breaking when subjected to flexing. One use for telephone wire is for putting insulated wire links on a pc board, or wherever permanent undisturbed wiring is required. Another type of single strand wire is tinned copper wire. This type of wire is available in the same

sizes as winding wire, a roll of 22 or 24 SWG tinned copper wire being useful for pc board links.

Multistrand wire

Multistrand wire is available in various sizes, and is usually measured by number of strands x diameter of each strand. Often only a current rating for the cable is given. For a typical low power, (around 1-2 amps), general usage wire size would be 10 x 0.025 mm (10/10 as it was called in pre-metric days); 24 x 0.2 mm (23/0.0076) being a size suitable for currents of around 7.5 amps. This type of wire is often referred to as 'hookup' wire.

The grading of the insulation is not always stated, although a 250 V rating will be specified if this is the case. It is important to use *only* 250 V rated insulated wire when connecting to the mains; this type of insulation is normally only present on cables rated at 5 amps or more. Where the voltage exceeds 1 kV, the use of specially insulated wire is necessary. Known as EHT cable, this wire has applications where a cathode ray tube forms part of the circuit.

An important point to note is that use of the correct wire size for power applications is essential. Many unpredictable faults can be introduced into a circuit by using power wiring of too light a gauge. If the circuit requires 2 amps use say, a 5 amp wire size. Power wiring should be as short as possible, and correctly clamped at either end to ensure optimum safety.

Other multistrand wire includes speaker



Telephone wire, often used for breadboarding.

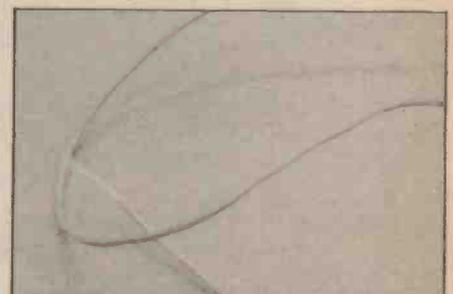

Common as mud hookup wire.

wire, mains rated power wiring (so called figure 8), highly flexible cable as used in meter probes and test leads (often comprised of over 500 strands of very fine wire) and various cable formats containing a number of individually insulated cables. The main considerations when wiring up projects are to use the most appropriate size wire for the task, use colour coding where possible (ie, red for positive, black for negative, blue for signal, etc), and ensure that the insulation is adequate for the voltages being used.

Signal wiring

Signal wiring often only requires a light gauge, and where a number of signal wires need to be taken from one area to another, the use of rainbow cable provides a neat and more easily traced job. Rainbow cable comes in various sizes; 12 or 16 colour coded multistrand wires moulded into a flat strip is typical. Computer cable is similar to rainbow cable in format, but is generally designed to be used with quick-connect connectors (IDCs, or insulation displacement connectors), and has only very limited colour coding.

The use of 'hookup' wire is also common for signal transfer applications, with different colours allowing easy tracing of the wiring. It is good practice to run this sort of wiring in a 'loom'. A loom is an arrangement to keep all the wiring together, and may be made by feeding the wires through plastic sleeving, using clamps, tape or binding to form a single trunking. Signal wiring should be as short as possible, and located away from heat sources, power transformers and any high energy areas of the circuit.

Coaxial cable

Coaxial cable is another type of wire commonly used for electronic signal distribution and, predictably, comes in many varieties. There is a distinction between 'coaxial' and 'shielded' cable which should be appreciated.

Shielded cable refers to coaxial style construction, where a central wire (or wires) is shielded by a surrounding braid of some sort. Shielded cable is designed for audio or video frequencies, and will have a capacitance per unit length specification.

Coaxial cable has a similar type of construction, but is designed for use at high frequencies (radio frequencies). Employing special types of insulating materials, coaxial cable will be given a 'characteristic impedance' value. It is possible to use coaxial cable in place of shielded cable, although it's more expensive, but never use shielded cable in place of coaxial. Common parlance generally refers to all shielded cable as 'coax', but the distinction is important.

Shielded cable

Shielded cable is available in various styles, including groupings of individual cables either surrounded by a common shield or individually shielded. The shield is normally connected to the common, or earth point of the circuit. This type of cable has a specified value of capacitance per metre, with a value of 100 pF/m being low, and 200 pF/m being typical. The capacitance becomes important if the wire length is substantial, or if the frequencies involved exceed 1 MHz. If the impedance of the circuit is low (around 100 ohms or less), the capacitance of the cable is not as critical, particularly for audio uses. For video frequency applications, a low capacitance cable should be used. Another concern involves the amount of signal isolation provided between adjacent shielded conductors within the cable. Different construction techniques provide various degrees of isolation, again important when cable lengths exceed more than a few metres.

Radio frequency coaxial cable

Coaxial cable is required in applications involving the transfer of signals with a fre-

TAPE DECK	AMPLIFIER
1 = LEFT INPUT	1 = LEFT OUTPUT
2 = EARTH	2 = EARTH
3 = LEFT OUTPUT	3 = LEFT INPUT
4 = RIGHT INPUT	4 = RIGHT OUTPUT
5 = RIGHT OUTPUT	5 = RIGHT INPUT

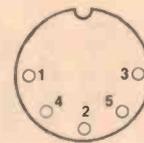

Figure 1. Arrangement of the 5-pin DIN plugs and sockets.

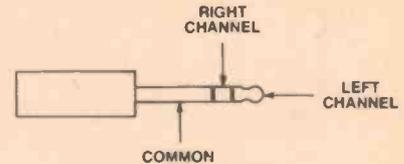

Figure 2. Standard for headphone connections.

quency greater than 3 or 4 MHz (radio frequencies). A common example is the distribution of the signal from a TV antenna where frequencies of 100 to 200 MHz occur. The impedance rating of the cable in this case will be 75 ohms, designed to match the impedance of both the signal source (antenna) and the load (TV set). This 'impedance matching' is essential for optimum transfer of the signal, the example illustrating how the impedance of the devices being connected determines the impedance of the cable.

Other characteristics of coaxial cable include its capacitance per metre, and its loss at a specified frequency (in dB/10 metre). A low loss 75 ohm coaxial cable would have a loss of around 1 dB/10 metres at 100 MHz, with a capacitance of about 60 pF/m. How 'lossy' the cable is depends on its construction, and bears no relation to its impedance.

Plugs and sockets

Plugs and sockets are available in many types, all designed for a specific use. In general, plugs and sockets are used to couple

Below. Rainbow and computer cable carry a number of signals through strings of multistrand wire. Right. Heavy duty coaxial cable used in the Anzac undersea cable and some lighter TV coax.

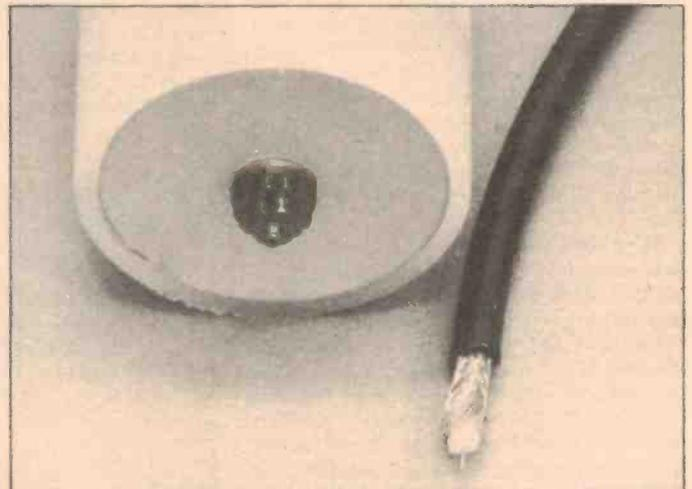
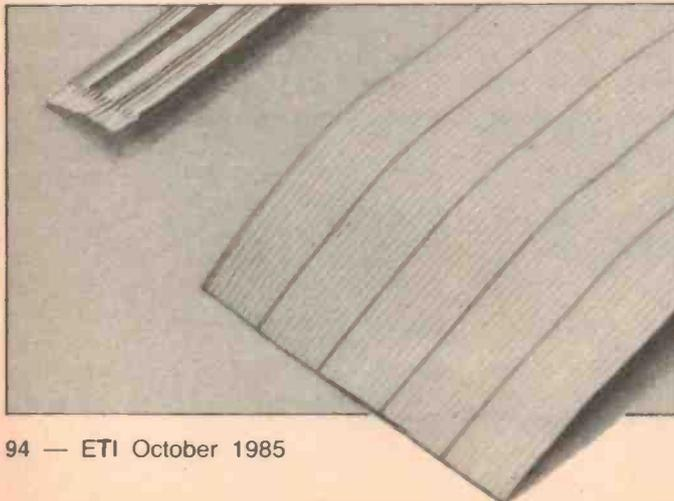

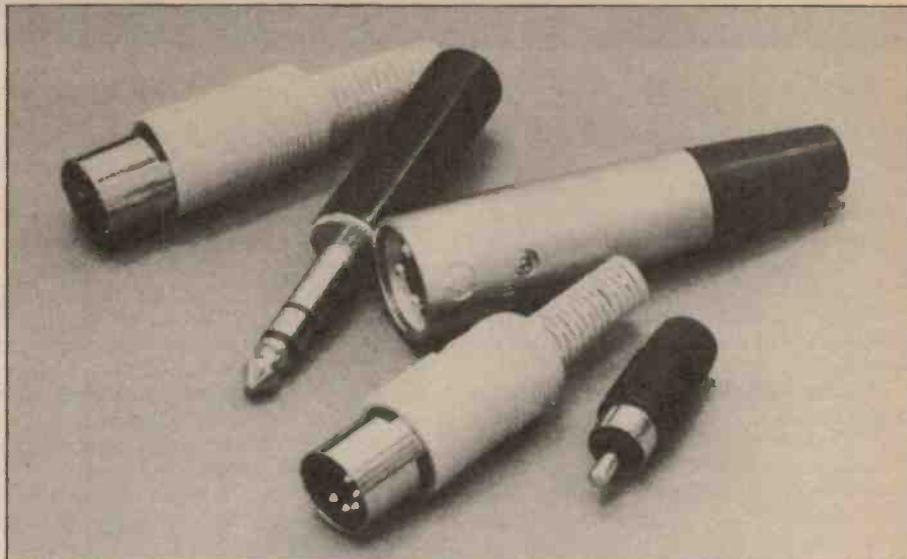
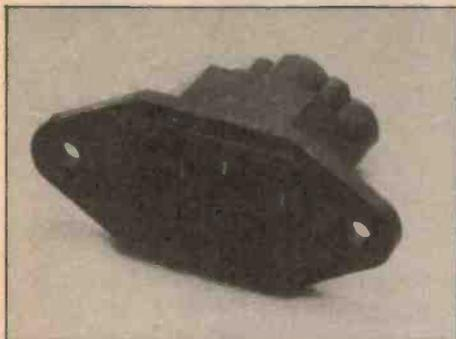

Above left. Shielded cable typically used in audio applications. Left. IEC mains plug. Above. Typical audio connectors including DIN, phono, Cannon and RCA plugs.

connecting wires, the wires either carrying power (ac or dc), or electronic signals. The signal wiring may be coax or conventional wiring, and the signals may be anything from audio to UHF signals. Different plugs and sockets are required for different tasks, and it is important to use the correct type to prevent signal or power losses.

Connecting power

Plugs and sockets used for connecting power carrying wires vary considerably in size depending on how much power needs to be coupled through. Basically, if there is any resistance to the current within the plug/socket combination, heat will be generated, causing a further increase in resistance, causing more heat!!! Very often, plugs and sockets designed for power applications will have a resistance specification included with a rated current and voltage capability. Typical varieties are the 'Jones' type plug/sockets, and the 'Molex' type nylon connectors. These types come in a variety of pin configurations, and are usually polarised to prevent inadvertent reversal of the union. Various 240 V plug/socket combinations abound, with the 3-pin IEC style becoming increasingly popular.

Often a plug/socket set may have to couple signal and power wiring in the one unit. A common means of doing this is to use a D subminiature connector, where the contact current rating is around 5 amps, and the resistance of the union is extremely low due to the gold plated contacts. These connectors come in various sizes, including 9-pin, 15-pin, 25-pin and 50-pin configurations, with styles varying from pc mount, direct solder types, even IDC varieties. These connectors find considerable use in digital and computer applications but are suited to most general purpose uses. The commonly used RS232 standard for computers uses a 25-pin D plug and socket, the plug being a DB-25P and the socket a DB-25S. The letter B refers to the shell size; the 9-pin being

an E size, 15-pin an A, 50-pin a D, etc.

Another means of providing a multiway connection is to use an edge connector, with the pc board having the plug and pc tracks all brought to one edge and spaced to mate with the female edge connector. In this case it is essential to plate the pc tracks that form the plug with either gold (preferably) or tin. Various track spacings are used, and sockets are available both for single and dual sided pc boards.

Audio coaxial connectors

Another range of connectors is that used with coax cable. For audio use, where shielded cable is employed, typical connectors are the RCA style, the DIN connector, phono plugs, Cannon connectors, to name some of the more common varieties. RCA connectors are virtually universal in their use in audio applications, and the sockets are available in line, panel mount, and multiway styles. Different plating materials identify the 'cheapies', with cadmium, nickel, silver alloy and gold plated types being available.

The DIN connector has also become a standard audio connection means, with various configurations being available in the plugs and sockets. The most usual is the 5-pin DIN connector, with the centre pin being earth, or common, and the remaining four providing a stereo input/output configuration. The casing around the actual connectors can also be connected to earth to provide more shielding if needed. Figure 1 shows a standard used in connecting the 5-pin DIN connector.

Another fundamental audio connector is the 'phono' type. Phono connectors come in three sizes, 2.5 mm, 3.5 mm and 6.5 mm. Mono and stereo types are available (it may be hard to get stereo in the 2.5 mm size), and these connectors are typically used for microphone or headphone connections, the 6.5 mm size being used in telephone switchboards. The phono socket has one feature

not usually found on other connectors, in that it has an arrangement whereby inserting the plug causes a contact to open within the socket, disconnecting a section of the circuit. Use is made of this in an earphone socket, where plugging in the earphone disconnects the speaker.

Other audio connectors include the Cannon range, generally used in professional installations, various styles being employed, with three pins being typical. A 240 volt Cannon style connector is also available, with a panel mount socket being employed to connect with a 3-pin line plug. Further brands include the Amphenol range with its almost unlimited variety of contact configurations, along with many others too numerous to mention.

Radio frequency connectors

Connectors designed for rf applications are numerous, each with its own particular advantage. The main difference between an audio connector and an rf connector is the material used to insulate the centre (or active) pin from the earth shield. Radio frequencies will often be bypassed to earth in ordinary audio connectors, with the coaxial cable used for rf signals being difficult to connect anyway.

A commonly used rf connector is one not unlike the RCA plug, called either a coaxial or rf connector. Various styles include panel mounting, line connectors, plastic or metal case varieties, etc. These are typically used in connecting a TV antenna to an input such as a VCR, TV set and so on.

Another very popular connector used for rf work is the BNC connector. The main difference between this connector and the latter, is the manner in which the coupling is arranged. In the rf connector, the connection is a push fit, whereas the BNC style has a bayonet type fitting. This, along with appropriate clamping of the cable to the connector provides a more robust arrangement. Many test instruments employ the BNC

STARTING ELECTRONICS 8

connector for connecting test leads. A wide range of BNC style connectors is available including a 3-way T piece, adaptors between connector types and various mounting styles. The BNC connector is useful for all coax type connections, including audio through to UHF. The only limitation is the physical size of the coaxial cable that can be attached, with 5 mm OD being about the maximum.

Another common connector, used in much the same way as the BNC type is the 'UHF' connector. These have a threaded coupling arrangement, which permits a weatherproof connection if required. They find use in CB radio applications, with the plug often referred to as a PL-259, and the socket as an SO-239. A wide variety of arrangements exist in these connectors, including a BNC to UHF adaptor, TEE pieces, right angles, panel mount, and so on.

Miscellaneous connectors

Other connectors are those used for car radio antennas, test leads, 300 ohm TV ribbon, spade connectors, terminal strips, terminal posts, Centronics connectors, and so on. Test leads, such as those used with a

multimeter, usually have a 4 mm plug to mate with the meter socket. The banana plug is one variety of plug used in this application. Spade connectors are used to connect single wires, with high current components often having a spade plug as the connection point. The Centronics plug is a plug designed for use with the Centronics standard, and many printers are fitted with this type of plug. Terminal strips allow wires to be joined in a semi-permanent fashion, with various sizes and styles being common.

The IDC format, produced as a variety of many types of multiway connectors, permits ribbon cable to be attached to the connector by merely compressing the fitting over the cable to cause the connection to be made. Special IDC cable must be used, with this arrangement permitting an almost instant connection to, for example, 40 individual wires.

In summary, a connector must be compatible with the wire size, be able to handle the required power, suit the environment and be correct for the type of signal being coupled. It is best to go for quality connectors, to avoid electrical 'noise' being generated, or an intermittent connection occurring.

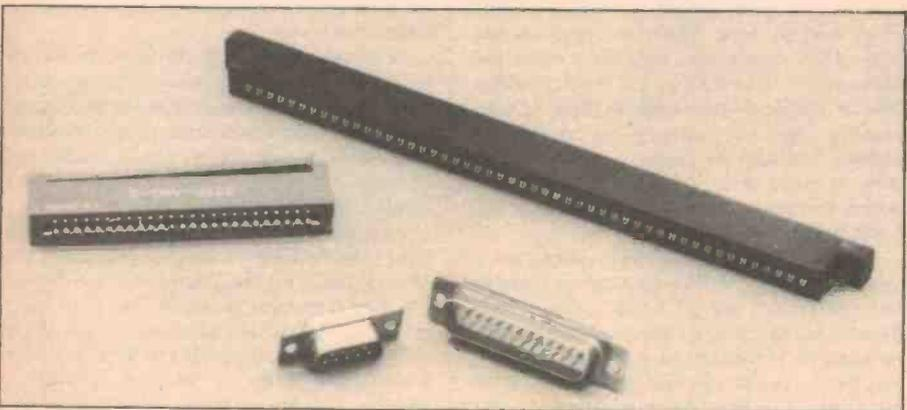
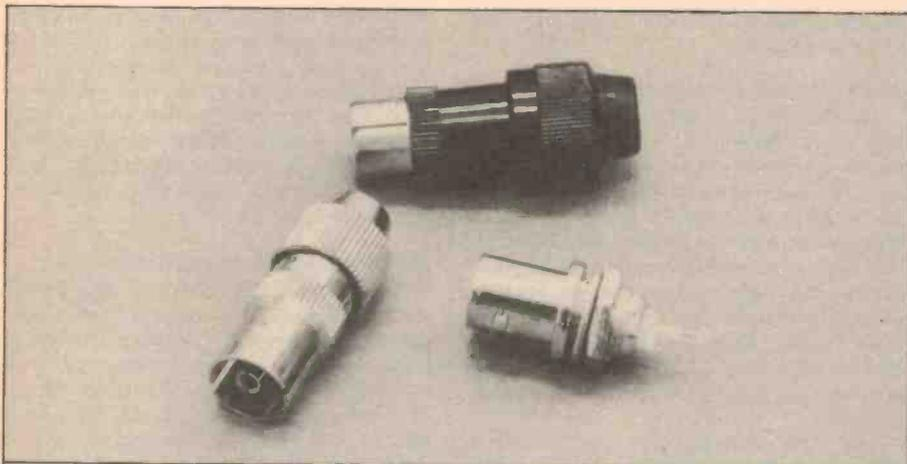

Above. Coaxial plugs often used in TV or UHF applications. Below. D connectors and edge connectors used in computer applications. Cables and connectors courtesy of Dick Smith Electronics.

Ian J. Truscott's

ELECTRONIC WORLD MORE & MORE

People are discovering us each week. Both the home enthusiast through to the small manufacturer.

★ ★ ★

COMPONENTS ●
TOOLS ● KITS

In any quantity, buy one, or one thousand, we're happy to oblige

SCHOOLS ● CLUBS
ETC.

Inquire about our bulk discount deals

Save yourself a trip to the city - come to

30 LACEY STREET
CROYDON

OR PHONE

(03) 723 3860/
723 3094

Mail orders welcome.

magazine holders/binders

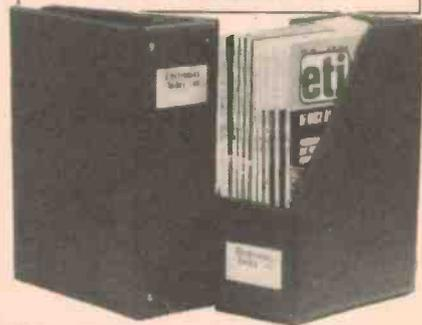

MAGAZINE BINDERS \$7.50
Ready to use binders with easy, clip-in fastener, covered in soft, decorator brown vinyl. Holds 12 issues of Electronics Today.

MAGAZINE HOLDERS \$7.00
Big, easy to assemble holders, covered in soft, decorator brown vinyl. Holds 12 issues (at least) of Electronics Today.

— SAVE WITH SIX —

6 Holders — only \$37.50
6 Binders — only \$39.95

Keep order in your valuable magazine collection. Send today for your holders and binders. Postage and packing additional: Please refer to Freepost reply card for charges.

ALL ELECTRONIC COMPONENTS

118-122 LONSDALE STREET, MELBOURNE, VIC. 3000. TEL: 662-3506

Division of DOTHAIN Pty. Ltd.

TALK ABOUT A HUGE RANGE OF KITS!

STEREO UNITS

- S1 ETI 484 Compressor Expander
- S2 ETI 482 50 watt per channel Amplifier
- S3 ETI 482A Preamp Board
- S4 ETI 482B Tone Control Board
- S5 ETI 485 Graphic Equalizer
- S6 ETI 480 50 watt Amplifier
- S7 ETI 480 100 watt Amplifier
- S9 ETI 443 Expander Compressor
- S10 ETI 444 Five watt stereo
- S12 ETI 438 Audio Level Meter
- S13 ETI 440 25 watt Stereo Amplifier including metalwork.
- S18 ETI 426 Rumble Filter
- S19 ETI 429 Simple Stereo Amplifier
- S21 ETI 417 Over led Distortion Monitor
- S35 ETI 470 60 watt audio amplifier module
- S36 ETI 4000 Series 60 watt stereo amplifier
- S37 ETI 451 Hum Filter for Hi-Fi systems
- S38 E.A. Stereo Infrared Remote Switch
- S39 ETI 455 Stereo Loudspeaker Protector
- S40 E.A. Super-Bass Filter
- S42 E.A. Stylus Timer
- S43 ETI 3000 Series Amplifier 25 wch
- S44 ETI 477 Mosfet power amp module inc. brackets
- S45 ETI 457 Scratch/Rumble Filter
- S46 ETI 458 VU Level Meter
- S47 ETI 479 Bndging Adaptor
- S48 ETI 5000 Series Power Amplifier
- S49 ETI 494 Loudspeaker Protector
- S50 EA Infrared TV Sound Control
- S51 HE 121 Scratch & Hiss Filter
- S52 EA 100W Sub Woofer Module
- S53 EA Stereo Simulator
- S54 EA Headphone Amp.
- S55 ETI 412 Peak Display

STAGE

- ST1 ETI 592 Light Show Controller (3 ch.) (1000 w/ch)
- ST2 ETI 593 Colour Sequencer (for use with ETI 592)
- ST3 ETI 551 Light Chaser 3 ch. 1000 w/ch
- ST4 E.A. Light Chaser 3 channel
- ST5 E.A. Twin Tremolo for Organs/Stage Amps
- ST7 ETI 499 150 w Mosfet P.A. Module
- ST8 ETI 498/499 150 w Public Address Amplifier
- ST9 E.A. Muscator IV
- ST10 EA Muscator III

PRE-AMPLIFIER AND MIXERS

- P1 ETI 445 Stereo Pre-amplifier
- P2 ETI 449 Balance Mic Pre-amplifier
- P6 ETI 419 Mixer Pre-amplifier — 4 ch.
- Mixer Pre-amplifier — 2 ch.
- P10 E.A. Playmaster 145 Mixer
- P11 ETI 446 Audio Limiter
- P12 ETI 471 High Performance Stereo Pre-amplifier — less FP & Backing Plate
- P13 ETI 473 Moving Coil Cartridge Pre-Amp
- P14 ETI 474 High to low Impedance Interface
- P15 ETI 467 4 Input Guitar/Mic. Pre-amp suits ETI 466 — includes power supply
- P16 E.A. Moving Coil Pre-Amplifier (Battery)
- P17 E.A. Moving Coil Pre-Amplifier (Plug pack)
- P18 ETI 478 MM Moving Magnet Pre-amp (Series 5000)
- P19 ETI 478MC Moving Coil Pre-amp (Series 5000)
- P20 ETI 478 Series 5000 Pre-Amplifier
- P21 E.A. Vocal Cancellor
- P22 ETI 416 Balanced Pre-amplifier
- P23 HE 112 Micromixer
- P24 EA Effects Unit
- P25 EA Stereo Simulator

GUITAR UNITS

- G1 ETI 447 Audio Phaser
- G2 ETI 413 2-100W Bridge Amp.
- G5 ETI 413 100 watt Guitar Amplifier
- G14 ETI 452 Guitar Practice Amplifier
- G15 ETI 466 300 watt Amp module
- G16 ETI 454 Fuzz Sustain
- G17 HE 102 Guitar Phaser
- G18 ETI 450A Bucket Brigade
- G19 ETI 450B Mixer for above
- G20 E.A. guitar Pre-amplifier
- G21 Sonics ME2 Sonics ME2 Wah Pedal-less pedal

AUDIO TEST UNITS

- AT1 ETI 441 Audio Noise Generator
- AT2 ETI 128 Audio Millivolt Meter
- AT4 ETI 102 Audio Signal Generator
- AT5 E.A. A.F. Tone Burst Generator
- AT7 ETI 137 Audio Oscillator
- AT9 HE 105 Bench Amplifier
- AT10 E.A. Audio Test Unit
- AT11 E.A. Function Generator
- AT12 ETI 464 Audio Test Unit

TIMERS

- T1 ETI 650 STAC Timer
- T2 ETI 564 Digital Wall Clock
- T3 E.A. Universal Timer and Stopwatch
- T4 ETI 540 Universal Timer
- T5 ETI 265 Power Down

T6 EA 4 Digit L.C.D. Clock or Control Timer

77 EA Event Counter

COMMUNICATION EQUIPMENT

- CE1 ETI 711 Remote Control Transmitter Switch
- CE2 ETI 711R Remote Control Receiver
- CE3 ETI 711D Remote Control Decoder
- CE4 ETI 711B Single Control
- CE5 Double Control
- CE6 ETI 711P Power Supply
- CE7 ETI 707A 144 Mhz Converter
- CE8 ETI 707B 52 Mhz Converter
- CE9 ETI 708 Active Antenna
- CE11 ETI 780 Novice Transmitter
- CE12 ETI 703 Antenna Matching Unit
- CE29 E.A. Short Wave Converter for 27 Mhz
- CE31 E.A. 27 Mhz Pre-amp
- CE32 E.A. 10-30 Mhz Pre-amp
- CE33 ETI 718 Shortwave Radio
- CE34 ETI 490 Audio Compressor
- CE35 ETI 721 Aircraft Band Converter (less XTALS)
- CE36 ETI 726 or 10 metre Power Amp
- CE37 ETI 475 Wide Band A.M. Tuner
- CE38 E.A. Masthead Pre-amplifier
- CE39 ETI 731 R.T.T.Y. Modulator
- CE40 ETI 729 UHF TV Masthead Converter
- CE41 ETI 735 UHF to VHF TV Pre-amp
- CE42 HE 104 AM Tuner
- CE43 HE 106 Radio Microphone
- CE44 E.A. R.T.T.Y. Demodulator
- CE45 E.A. Voice Operator Relay
- CE46 ETI 733 RTTY Converter for Microbee
- CE47 ETI 1517 Video Distribution Amp.
- CE48 EA Video Enhancer
- CE49 Wideband Amp.
- CE50 ETI 1518 Video Enhancer
- CE51 EA VCR Sound Processor

METAL DETECTORS

- MD1 ETI 549 Induction Balance Metal Detector
- MD2 ETI 561 Metal Locator
- MD3 ETI 1500 Discriminating Metal Locator (undrilled case)
- MD4 ETI 1500 Discriminating Metal Locator (predrilled case)
- MD5 ETI 562 Geiger Counter with ZP 1310 Tube
- MD6 ETI 566 Pipe and Cable Locator
- MD7 E.A. Prospector Metal Locator including headphones

TEST EQUIPMENT

- TE2 ETI 133 Phase Meter
- TE4 ETI 129 R.F. Signal Generator
- TE6 ETI 706 Marker Generator
- TE8 ETI 122 Logic Tester
- TE9 ETI 124 Tone Burst Generator
- TE11 ETI 116 Impedance Meter
- TE12 ETI 533 Digital Display
- TE14 ETI 704 Cross Hatch Dot Generator
- TE16 ETI 120 Logic Probe
- TE17 ETI 121 Logic Pulsar
- TE34 ETI 487 Real Time Audio Analyser
- TE35 ETI 483 Sound Level Meter
- TE36 ETI 489 Real Time Audio Analyser
- TE37 ETI 717 Cross Hatch Generators
- TE38 E.A. 3 Mhz Frequency Counter
- TE42 E.A. Transistor Tester incl. Bipolar & F.E.T.S.
- TE43 ETI 591 Up Down Pre-settable Counter
- TE44 ETI 550 Digital dial (less case) includes ETI 591
- TE45 ETI 144 Expanded Scale R.M.S. Voltmeter
- TE46 ETI 148 Versatile Logic Probe
- TE47 ETI 724 Microwave Oven Leak Detector
- TE48 ETI 150 Simple Analog Frequency Meter
- TE49 ETI 151 Linear Scale Ohm Meter
- TE50 ETI 152 Linear Scale Capacitance Meter
- TE51 E.A. Digital Capacitance Meter
- TE52 ETI 589 Digital Temp. Meter
- TE53 E.A. T.V. C.R.O. Adaptor
- TE54 E.A. XTAL Locked Pattern Generator
- TE55 E.A. Decade Resistance Sub Box
- TE56 E.A. Capacitance Sub Box
- TE57 E.A. Decade Capacitance Sub Box
- TE58 E.A. Tantalum Capacitance Sub Box
- TE59 ETI 140 1 Ghz Frequency Meter/Timer
- TE60 ETI 572 PH Meter
- TE61 ETI 135 Panel Meter
- TE62 E.A. Modulated Signal Injector
- TE63 HE 103 Transistor Tester
- TE64 HE 111 Ohm meter
- TE65 ETI 157 Crystal Marker
- TE66 ETI 161 Digital Panel Meter
- TE67 ETI 255 Analog Thermometer
- TE68 EA Transistor Tester
- TE69 ETI 175 20 Mhz Dig. Frequency Meter (Hand held)
- TE70 ETI 166 Function Pulse Generator
- TE71 X-ral Locked Pattern Generator

MODEL TRAIN UNITS (see also "SOUND EFFECTS")

- MT1 ETI 541 Model Train Control
- MT2 E.A. 1974 Model Train Control
- MT6 E.A. 1978 Train Control less Front Panel

1978 Train Control with Front Panel

SOUND EFFECTS

- SE1 E.A. Sound Effects Generator*
 - SE2 E.A. Musical Tone Generator
 - SE3 E.A. Cyton Voice
 - SE4 E.A. Steam Whistle
 - SE5 ETI 607 Sound Effects
 - SE6 E.A. 492 Audio Sound Bender
 - SE7 E.A. Electronic Sea Shell Sound Effects
 - SE8 ETI 469A Percussion Synthesiser
 - SE9 ETI 469B Sequencer for Synthesiser
 - SE10 EA Effects Unit
- * set as for Steam Train and Prop Plane noise

VOLTAGE/CURRENT CONTROLS

- V1 ETI 481 12 volt to $\pm 40v$ D.C. 100 watt Inverter
- V2 ETI 525 Drill Speed Controller
- V6 E.A. 1976 Speed Control
- V10 E.A. Zero-voltage switching heat controller
- V11 E.A. Inverter 12v D.C. input 230v 50 Hz 300VA output not incl. switch 35 amp
- V12 ETI 1505 Fluorescent Light Inverter
- V13 EA Electric Fence
- V14 ETI 1506 Xenon Push Bike Flasher
- V15 ETI 1509 DC-DC Inverter
- V16 ETI 1512 Electric Fence Tester
- V17 EA Fluro Light Starter
- V18 ETI 1524 Electronic Mouse Trap

WARNING SYSTEMS

- WS1 ETI 583 Gas Alarm
- WS3 ETI 528 Home Burglar Alarm
- WS4 ETI 702 Radar Intruder Alarm
- WS7 ETI 313 Car Alarm
- WS12 ETI 582 House Alarm
- WS14 E.A. 1976 Car Alarm
- WS15 E.A. 10 Ghz Radar Alarm
- WS16 E.A. Light Beam Relay
- WS17 ETI 247 Soil Moisture Indicator
- WS18 ETI 250 Simple House Alarm
- WS19 ETI 570 Infrared 'Trip' Relay
- WS20 ETI 585 T&R Ultrasonic Switch
- WS21 ETI 330 Car Alarm
- WS22 ETI 322 Over Rev Car Alarm incl. case
- WS24 ETI 1506 Xenon Bike Flasher
- WS25 ETI 340 Car Alarm
- WS26 EA Deluxe Car Alarm
- WS27 EA Ultrasonic Movement Detector

PHOTOGRAPHIC

- PH1 ETI 586 Shutter Speed Timer
- PH3 ETI 5148 Sound Light Flash Trigger
- PH4 ETI 532 Photo Timer
- PH7 ETI 513 Tape Slide Synchronizer
- PH12 ETI Sync-a-Slide
- PH14 ETI 558 Mast Head Strobe
- PH15 ETI 553 Tape Slide Synchronizer
- PH16 E.A. Digital Photo Timer
- PH17 ETI 594 Development Timer
- PH18 ETI 588 Sound or light operated Flash Trigger including optional parts
- PH19 E.A. Sound Triggered Photoflash
- PH20 HE 109 Extra Flash Trigger
- PH21 E.A. Photographic Timer

POWER SUPPLIES

- PS1 ETI 132 Experimenters Power Supply
- PS2 ETI 581 Dual Power Supply
- PS3 ETI 712 CB Power Supply
- PS4 ETI 131 Power Supply
- PS6 ETI 105 Laboratory Power Supply
- PS7 ETI 111 I/C Power Supply
- PS9 E.A. 1976 Regulated Power Supply
- PS11 E.A. C.B. Power Supply
- PS12 ETI 142 Power Supply 0-30 v 0-15 A (fully protected)
- PS13 ETI 472 Power Supply
- PS14 E.A. Power Supply for Dream 6800
- PS15 ETI 577 Dual 12V supply
- PS16 E.A. Power Saver
- PS17 ETI 480 PS Power Supply for ETI 480 (100 watt Amp.)
- PS18 E.A. Bench Mate Utility Amplifier/Power Supply
- PS19 HE 108 Power Supply
- PS20 ETI 163 0-40 V, 0-5 A
- PS21 EA Dual Tracking Power Supply

COMPUTER AND DIGITAL UNITS

- C1 ETI 633 Video Synch Board*
- C2 ETI 632M Part 1 Memory Board V.D.U.*
- C3 ETI 632P Part 1 Power Supply V.D.U.*
- C4 ETI 632A Part 2 Control Logic V.D.U.*
- C5 ETI 632B Part 2 Control Logic V.D.U.*
- C6 ETI 632C Part 2 Character Generator V.D.U.*
- C8 ETI 632 U.A. R.T. Board*
- C9 ETI 631-2 Keyboard Encoder*
- C10 ETI 631 A.Sch. Keyboard Encoder
- C14 ETI 638 Eprom Programmer
- C15 ETI 637 Cuts Cassette Interface
- C16 ETI 651 Binary to Hex Number Converter

- C17 ETI 730 Getting Going on Radio Tele Type
- C22 ETI 660 Basic Computer
- C23 ETI 660 Basic Computer incl. colour option on board expandable memory, RF modulator, case and power supply

- C24 ETI 760 Video RF Modulator
- C25 E.A. Eprom Programmer
- C26 ETI 668 Microbee Eprom Programmer
- C27 ETI 733 RTTY Computer Decoder
- C28 EA Video Amp for Computers
- C29 ETI 649 Microbee Light Pen
- C30 ETI 675 Microbee Serial — Parallel Interface
- C31 ETI 688 Programmer for Fusable — Link Bipolar Proms

- C32 ETI 676 RS232 for Microbee
- * all V.D.U. projects priced less connectors

BIO FEEDBACK

- BF1 ETI 546 G.S.R. Monitor (less probes)
- BF2 ETI 544 Heart Rate Monitor
- BF3 ETI 576 Electromyogram

AUTOMOTIVE UNITS

- A1 ETI 317 Rev. Monitor
- A2 ETI 081 Tachometer
- A3 ETI 316 Transistor Assisted Ignition
- A4 ETI 240 High Power Emergency Flasher
- A6 ETI 312 Electronic Ignition System
- A7 ETI 301 Vari-Wiper
- A14 E.A. Dwell Meter
- A15 E.A. Variwiper
- A16 E.A. Tacho for Tune-ups
- A17 E.A. Ignition Antyler and Tachometer
- A18 E.A. Strobe Adaptor for Ignition Analyser
- A19 E.A. 1975 C.D.J. Capacitor discharge Ignition
- A22 ETI 318 Digital Car Tachometer
- A23 ETI 319A Variwiper Mk. 2 (no dynamic braking)
- A24 ETI 319B Variwiper Mk. 2 (for dynamic braking)
- A25 ETI 555 Light Activated Tacho
- A26 ETI 320 Battery Condition Indicator
- A27 E.A. Transistor Assisted Ignition
- A28 ETI 324 Twin Range Tacho less case
- A29 ETI 328 Led Oil Temp Meter less V.D.O. probe
- A30 ETI 321 Auto Fuel Level Alarm
- A31 ETI 332 Stethoscope
- A32 ETI 325 Auto Probe Tests Vehicle Electricals
- A33 ETI 333 Reversing Alarm
- A34 E.A. Low fuel Indicator
- A35 ETI 326 Led Edganded Voltmeter
- A36 ETI 329 Ammeter (expanded scale)
- A37 ETI 327 Turn and Hazard Indicator
- A38 ETI 159 Expanded Scale Voltmeter
- A39 EA Optoelectronic Ignition
- A40 ETI 335 Viper Controller
- A41 EA Ignition Killer for Cars
- A42 EA L.C.D. Car Clock
- A43 EA Cruise Control
- A44 ETI 337 Automatic Car Aerial Controller

ELECTRONIC GAMES

- EG1 ETI 043 Heads and Tails
- EG2 ETI 068 L.E.D. Dice Circuit
- EG3 E.A. Electronic Roulette Wheel
- EG4 ETI 557 Reaction Timer
- EG5 ETI 814 Dinky Die
- EG6 E.A. Selectalot
- EG7 HE 107 Electronic Dice
- EG8 E.A. Photon Torpedo
- EG9 HE 123 Alien Invaders
- EG10 EA Roulette Wheel

MISCELLANEOUS KITS

- M1 ETI 604 Accentuated Beat Metronome
- M4 ETI 547 Telephone Bell Extender
- M5 ETI 602 Mini Organ (less case)
- M7 ETI 044 Two Tone Doorbell
- M10 ETI 539 Touch Switch
- M25 E.A. Digital Metronome
- M37 ETI 249 Combination lock (less lock)
- M39 E.A. Electronic Combination lock (including lock)
- M46 E.A. Power Saver for induction motors
- M48 E.A. Lissajous Pattern Generator
- M53 ETI Soil Moisture Alarm
- M54 E.A. Electrochune Keyless Organ
- M55 E.A. Pools/Lotto Selector
- M56 ETI 256 Humidity Meter
- M57 ETI 257 Universal Retay Driver Board
- M58 E.A. Simple Metronome
- M59 ETI 1501 Neg. Ion Generator
- M60 ETI 1516 Sure Start for Model Aeroplanes
- M61 ETI 412 Peak Level Display
- M62 ETI 1515 Motor Speed Controller
- M63 ETI 1520 Wideband Amplifier
- M64 EA Phone Minder
- M65 EA Motorcycle Intercom
- M66 EA Simple L.C.D. Clock
- M67 EA Ultrasonic Rule

Note: We do not stock sub-standard poor quality components.

**PLUS MANY, MANY MORE KITS WHICH WE CANNOT LIST HERE!!!
JUST CONTACT US FOR PRICE & AVAILABILITY.**

TRADE AND RESELLER ENQUIRIES WELCOME.

SHOP AROUND

ETI-169: The low distortion audio oscillator

In order to get the best out of this project it is important to buy the parts specified, or be prepared to accept some diminution of performance. Notice that all the resistors are 2%. If in doubt buy one percenters: don't go the other way. Also note that the trim-pots are cermet types. The ordinary carbon variety is not recommended. The same remarks apply to the capacitors. Although most people don't carry components like these around in the jiffy box you should have little trouble finding them. All the semis are as common as mud. If you do run into problems, Geoff Wood, 656A Darling St, Rozelle, NSW 2039, (02)810-6845 is definitely supplying kits. The other usual suppliers are worth a ring as well.

ETI-343: Car alarm switch

This month we publish the second part of the infrared car alarm switch. Construction is quite straightforward, and involves no strange components. Kits are available from Hicom Unitronics, 7 President Lane, Carlingbah, NSW 2229, (02)524-7878. These kits include both transmitter and receiver elements.

ETI-665 Computer routing switch

The main justification for doing this project is that our office is getting to be a mad tangle of computer ribbon, and we are starting to wear out plugs and patience. Our new young engineer will not take kindly to people who refer to this as the computer rooster. It really is quite straightforward, with the exception of the board, which has some fairly dense track work. We suggest you don't attempt your own etching unless you thrive on challenge.

Artwork

For those constructors willing and able to make their own pc boards and/or front panels, we can supply same-size film transparencies of the artwork, positives or negatives as you require. From the list given below, select what you want and address your request/order to:

'ETI-xxx Artwork'
ETI Magazine
PO Box 227,
Waterloo NSW 2017

When ordering, make sure you specify positives or negatives, according to the process you use. Your cheque or money order should be made payable to 'ETI Artwork Sales'. Prices for the artwork for this month's projects are as follows:

ETI-169 (front panel)	\$5.00
(pcb)	\$9.00
ETI-343 (pcb)	\$8.00
ETI-665 (front panel)	\$5.00
(pcb)	\$10.87

MINI MART

FOR SALE: VIC 20 WITH Dataset, paddles and 5 games cartridges — Serpentine, Allen, Apple Panic, Mission Impossible, Star Battle and others. Worth \$320, sell \$140 ono. (03)720-1517 after 7pm weekdays.

WANTED: PEAK/HIOKI AS100D multimeters, sweep marker generator/wobulator, FM stereo generator. M. Sheriff, 457 Sydney Rd, Balgowlah, NSW 2093. (02)949-2454 bh, 982-6525 ah.

FOR SALE: Z80 S100 DEVELOPMENT system, 8" DSDD disk drive, CP/M, Pascal MT+, Basic, Macro Assembler. \$2000 ono. Ray Suryn (02)609-7370 ah, 27-2252 bh.

WANTED: NOS-BASICODE any programs and info to test Amstrad routines. Will return and refund postage. P. Lukes, 26 Noll St, Toowoomba, Qld 4350. (076)35-5822.

WANTED: ETI-660 COLOUR computer, 3K RAM with transformer, with or w/out case. Aldan (08)379-001 ah, not Sat.

WANTED: CIRCUIT DIAGRAM for Contact PSC-161 transceiver. Also circuit diag and supplier of spare pts for Chlnon disk drive F-051 MD. B Connors, C/- Gunnedah High School, Marquis St, Gunnedah, NSW 2380.

WANTED: CIRCUIT DIAGRAM for Sinclair 2X-81. Sean Lincolne, PO Box 56, Rivett, ACT 2611. (062)88-3161.

FOR SALE: OCTAGON S100 dual processor board Z80/8088. Includes floppy controller, two serial ports, 8 level interrupt controller, CPM 80/86 with full documentation. \$650. (02)888-7624.

WANTED: 50242 or AY-1-0212 top octave generator chip. Contact Peter Furnell, 80 Taylor St, Annandale 2038. Ph. a.h. (02)660-1225 or b.h. (02)88-9001.

WANTED: AUDIO Cyclopeda by H. M. Tremaine, 2nd edition, 1969. Phone (09)276-9339.

FOR SALE: 16K MICROBEE PLUS with Wordbee/EDASM ROMS, hi-res monitor with built-in Compumuse kit, ETI 668 EPROM Programmer, games, joystick, manuals. Worth \$850, sell for \$490. Ph (076)35-6764.

FOR SALE: TELETYPE EQUIPMENT: Model 15 page printer \$40, model 14 tape transmitter \$30, model 14 tape punch \$35. All working. (02)660-3269 Thursday, Friday.

WANTED: TECHNICAL data on a Sorcerer and the S-100 Expansion Unit. Also want a Development PAC (ROM-Pack). Mark Trethewey. (067)34-5383.

FOR SALE: MICROBEE, EDASM ROMS with manual \$15; network ROM for IC model \$5. Ph. (02)680-3453.

• We'll publish up to 24 words free of charge for you. Copy must be with us by the first of the month preceding the month of issue. Please print or type advertisements clearly! Every effort will be made to publish all advertisements received; however, no responsibility for so doing is accepted or implied. We reserve the right to refuse advertisements considered unsuitable.

• Conditions: Your name and address plus phone number (if required) must be included with the 24 words. Reasonable abbreviations, such as 25 W RMS or 240 Vac, count as one word. Advertisements must be private and relate to electronics, audio, communications, computing, etc — general advertisements cannot be accepted. Send your advertisement to:
ETI Mini-Mart, P.O. Box 227, Waterloo NSW 2017.

TELECTRAN

TRANSFORMER MANUFACTURERS

POWER TRANSFORMERS

1VA up to 100VA
fitted with pins for printed
circuit board mounting.
150VA to 250VA
with screw or QC terminals.

Full range of
**FLAT MOUNTED
TRANSFORMERS**
from as small as
5VA up to 500VA.

**AUDIO MATCHING
TRANSFORMERS**
**100V line to low
impedance.**

Printed Board Mounting also
Screw or Tag Terminals

TOROID WINDINGS for
Filters or Switching Applications.
High Production of Custom
Designs.

Production Capacity:
always available for winding of
POT CORES
RM CORES
EP CORES
EE, E and U or L CORES
FERRITE AND POWDERED
IRON TOROID WINDINGS A
SPECIALITY.

**FULL RANGE OF STOCK
TRANSFORMERS AVAILABLE
MANUFACTURING FACILITIES
FOR TRANSFORMERS UP TO
35KVA SINGLE OR 3 PHASE.**

PLEASE WRITE FOR DETAILS

TELECTRAN

59c MYOORA RD.,
TERREY HILLS. 2034 N.S.W.

OR PHONE (02) 450-2868
(02) 450-2395

Robert Ford & Co. Pty Ltd

You don't have to plug it in to appreciate this function generator.

In fact, you may never plug it in. Because the Model 20 can operate off internal NiCad batteries*, as well as external ac or dc sources.

That gives you complete freedom from ground loops—and power outlets.

But don't get the idea this is a toy. It covers a wide 0.002 Hz to 2.1 MHz frequency span in seven overlapping ranges. Model 20 can be triggered and gated, or operated as a voltage controlled generator, and it outputs sines, triangles or squares with up to 20 volts peak-to-peak amplitude. There is also a TTL pulse output that can drive up to 20 loads.

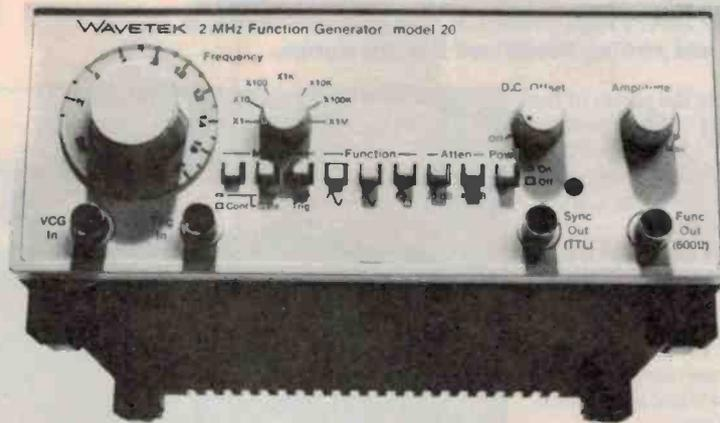

SCIENTIFIC DEVICES AUSTRALIA PTY. LTD.

VIC. 2 JACKS RD., SOUTH OAKLEIGH 3167. (03) 579 3622. TELEX: AA 32742
 N.S.W. 559A WILLOUGHBY RD., WILLOUGHBY 2068. (02) 95 2064. TELEX: AA 22798
 S.A. 31 HALSEY RD., ELIZABETH EAST 5112. (08) 255 6575. TELEX: AA 88125

Master the Microprocessor

Learn how Microprocessors really work ... the practical way.

The Purpose of this Course

There is a considerable, expanding and world-wide demand for people with a real knowledge of microprocessors and general computer technology. Such people are needed to design and evaluate systems and to assess and develop the enormous range of possible applications, both present and future, of microprocessors and to understand the installation and servicing of the main types of equipment of which they may form the most vital component.

(A microcomputer has already been produced to replace the mechanical programmer on a domestic washing machine, for example.)

This Course provides the necessary basic information to enable a student to really understand the functioning of microprocessors and their supporting circuitry,

usually referred to as the "hardware". This is backed up by showing how to program a microcomputer (or produce its "software") in the most fundamental form of computer language called "machine code". No previous knowledge of computers is necessary, though a little basic knowledge of electronics plus digital and logic circuits will be found helpful.

A special introductory short course is available to provide this back-ground information, if required by an individual student on the course without extra fee.

Student—Tutor Contact

A qualified Tutor is available to every Student throughout this Course in order to deal with any queries which may arise and to assess certain questionnaires which are issued to Students throughout the period of training.

Certificate

Issued to all Students completing the Course successfully. Course covers main requirements of the City and Guilds Certificates in Computers.

Practical Self Study Course



FREE COLOUR BROCHURE

Post coupon now. The Australian School of Electronics Pty Ltd., P.O. Box 108, Glen Iris, Victoria, 3146. Offices at 219 Balaclava Rd., Caulfield North

Please send your brochure without any obligation to:

Name

Address

ETI 8 83

Postcode

How the Course is organised

The basis for the practical work in the Course is the Microcomputer. This is supplied completely assembled and ready to use.

The Course text is carefully arranged in sequence so that each new section follows logically from previous work. Hardware description and programming technique progress together, so that the Student is discouraged from treating them as distinctly separate subjects. Following each section of descriptive text, detailed instructions are given in order to use the Microcomputer to provide a practical demonstration of each new function or technique. This provides a very powerful way of learning precisely how the system operates, and enables any possible ambiguities in the Student's mind to be quickly resolved.

Progress at BBC sites

The first transmitter in the £23 million rebuilding of Rampisham, one of the BBC's high power UK transmitting stations, is in operation and serving Russia and Eastern Europe.

It uses double the power of the old transmitters — 500 kilowatts instead of 250 — and the aerial is a prototype of a new design developed by Transmitter Capital Projects Department.

The scheme at Rampisham, in Dorset, is now almost halfway through its four year programme. The next step involves two more 500 kilowatt transmitters and six new aerials, which are planned to come into operation later this year.

When the Rampisham re-engineering is completed there will be ten transmitters serving any of the 34 aerials that will be on site. A computerised control system will handle the switching. A number of advances have been incorporated to provide a better signal overseas, with less interference, and to give the BBC more flexibility in its use of transmitter resources.

All of the new transmitters will be capable of automatic tuning over the whole of the high frequency (shortwave) spectrum, and each aerial can operate on four high frequency bands instead of two, as at present.

For the first time all feeders carrying signals between the switching station and the aerials will be screened, using a total of 19 kilometres of aluminium trunking to protect against the



The control room at the BBC studios in Bush House, London, from which the World Service in English and 38 other languages is fed to transmitters in the United Kingdom and via satellite to overseas relay bases, 24 hours a day.

weather, dust, birds and the smoke from stubble burning (which in the past has caused operational problems).

Noel Sudbury, who heads the projects, said the biggest difficulty so far has been carrying out the work while maintaining a service.

Some of the transmissions Rampisham normally carries have been transferred to Daven-

try and Skelton. The old 250 kilowatt transmitters have been removed and reinstalled at Skelton, and the transmitter building on the Rampisham site has been completely gutted.

"It is an expensive project, partly because of the sheer cost of raw materials involved," said Noel Sudbury. "For example, each aerial contains between three and four tons of copper.

"It is something of a race against time to come in on target. Because of the need for speed, only nine more of the new aerials are of the specially developed TCPD design, with 12 others being provided by the American TCI company. Then we'll decide who will produce the last 12 aerials, depending on how the previous lot have performed." — Arthur Cushen

Wagga hamfest

Over the weekend of 26-27 October, the Wagga Amateur Radio Club is to hold an Amateur Radio Convention and hamfest, continuing the long tradition of conventions and hamfests reaching back to the origins of amateur radio in the Riverina area.

A new dimension to this year's convention will be the inclusion of the inaugural Australian National Fox Hunting

Championships. The purpose of the championship is to find the Australian champion fox and hidden transmitter hunter.

In addition to the National Championships the convention will also conduct hunts for beginners and more professional hunters. Parts of both the national and the local hunts will be televised back to the convention site by the local ATV repeater. The local surrounds of Wagga

provide a magnificent backdrop to the running of both events.

Many trade displays will be descending on Wagga Wagga for the weekend. This will provide an excellent venue for the perusal of the most recent technological releases in the amateur radio field. Of course all displays will be looking to lighten the load on the return home so bargains are sure to be the order of the day.

Displays to be featured include a vintage steam engine display, remote controlled aircraft display, vintage radio display with many other exciting activities.

To ensure accommodation you should contact the Wagga Amateur Radio Club, PO Box 294, Wagga Wagga, NSW 2650. (069)26-1532.

OVERSEAS RELAYS

Hong Kong: A survey of the chosen site at Tsang-Tsui, south-west of the New Territories, has been completed and the acreage needed has been identified. It is mainly Crown land, but complexities of multi-purchase will not be wholly avoided since some individual leaseholders will have to be bought out. When completed, the four-acre site will contain two 300 kW transmitters beaming north and north-east to reach Peking, Japan, Korea and beyond. It will be the smallest BBC External Services station — land in Hong Kong is scarce and among the most expensive in the world. The whole project will cost £8.5 million.

Seychelles: The sites for the receiving and transmitting stations have been purchased and are on the west coast of Mahe. The area is 16 acres and will house two 300 kW transmitters in the transmitting building; this number will be eventually increased to four. Work has already started on the project.

Cyprus: The four new 250 kW transmitters are in operation, carrying various BBC External programmes.

Satellites: All of the BBC External transmitting sites are linked by satellite; they are Cyprus, Masirah, Singapore Antigua and Ascension. The programmes are fed from BBC studios in Bush House, London, over various satellites direct to the relay stations for rebroadcast. A recent comment on the BBC "Letterbox" programme suggested that listeners wishing to get accurate time should tune direct to London, and not use the GMT time signal as received from a BBC relay station because it was a quarter of a second slow.

Intelligent radio modem

The CPU-100 is a new micro-processor-controlled radio data modem designed by GFS to provide data communications over a narrowband HF, VHF or UHF radio system. It performs this task using either standard Baudot or ASCII codes. Additionally the CPU-100 may add extra bits to the codes in order to perform error detection and/or correction.

Because it is intelligent and relies on internal firmware its operating facilities may be easily reconfigured to suit a particular user's requirements. Currently a number of versions exist, their difference lying mainly in the software that resides in ROM. All are designed to connect directly to a dumb terminal/stand alone computer/TTY KSR printer via the RS232 port. The RS232 I/O baud rate is user selectable from 50 to 19200 baud via an internal DIP switch.

The currently available commercial version of the CPU-100 operates as a fully transparent interface between the user's remote terminal, narrowband radio bearer and mainframe computer. It is capable of oper-

ating either as a full duplex system (using a duplex radio link), a half duplex system or simplex depending on the user's requirements. Error detection and/or full error correction can be provided if required. Up to 2400 baud rate may be used over the bearer depending on its quality.

An amateur radio version of the CPU-100, the CPU-100A, is also available. It requires only a dumb terminal to provide its

user with a complete RTTY station. Operating modes include both Baudot and ASCII along with user variable baud rates and selective call recognition. Three large user memory buffers as well as a call sign buffer are also provided. All memory is fully backed up against failure of the 12 volt power source.

For more information contact GFS, 17 McKeon Road, Mitcham, Vic 3132. (03)873-3777.



VOA's Caribbean services

The Voice of America has been gradually building up a network of stations in the Caribbean area and the first to operate was VOA Antigua, transmitting on 1580 kHz with 50 kW. Then followed the VOA broadcast in Costa Rica on 930 kHz with 50 kW using the slogan Radio Costa Rica.

VOA has also announced further plans to establish transmitters in Puerto Rico on medium and shortwave and, according to the BBC, a site of 500 hectares near Cabo Rojo has been chosen. Programmes will be beamed to the Caribbean and South America.

Another BBC report indicates that the US Department of State is building two powerful relay stations in Belize for the Voice of America, to become operational later this year. More than \$US42m has been allocated for their construction. The stations will cover an area from Mexico's

south eastern regions to Costa Rica. The US government is to help modernise Radio Belize as part of its contract to build the relay stations in that country.

A verification from Radio Marti has been received in the form of a letter, indicating that the shortwave transmitters from Greenville, North Carolina are using the power of 250 kW on all frequencies, except 11815 and 11960 kHz. The letter was signed by Fran Masterman, management assistant, Radio Marti Program, Voice of America, Washington DC 20547, USA and our verification confirmed reception of the medium-wave frequency of 1180 kHz. The shortwave transmissions are 0930-1200 UTC on 6075 kHz; 1200-1400 UTC on 9570 kHz; 1400-1730 UTC on 11815 kHz; 2030-2200 UTC on 11960 kHz and 2300-0300 UTC on 9660 kHz.

— Arthur Cushen

Map

GFS Imports has published a great circle map centred on Melbourne. The map can be used for establishing the correct direction to any point on the Earth from Melbourne. It is also useful for establishing the distance.

However, the great circle map cannot be used to establish dis-

tance or direction between any other points on the Earth's surface. This is a function of the projection method, which tries to represent a ball shaped object (the Earth) as flat. Notice that a Mercator projection, the one with lines of latitude and longitude at right angles to each other, also has massive distortions in it, getting worse close to the poles.

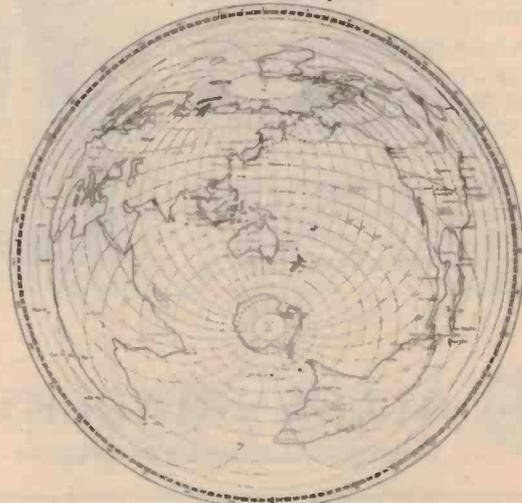

Adventist World Radio broadcasts from Italy

A new station, AWR Europe has been heard on 6145 kHz at 0600 UTC with English gospel programming. The broadcasts are announced as operating Saturday and Sunday 0400-0430 UTC in Russian, 0500-0530 UTC in Romanian, with English 0600-0700 UTC seven days a week. Other transmissions are 1600-1700 UTC English, and 0800-0900 UTC, 1500-1600 UTC in German.

The first broadcasts from the new shortwave station in Italy took place on January 30, 1985. Test broadcasts have continued intermittently since then. These tests have been made using about 3 kW of transmitter power and a provisional dipole

antenna, while a high gain LP 1002 directional antenna went into service on February 18. Though testing will continue to take place at various hours, a regular schedule of programming is planned for 0600-0900 and 1500-1700 UTC daily. Other language services are expected soon. This low power, short-wave station operated by AWR is being established in conjunction with a new FM station in Forli (the eighth such local station in Italy operated by the Adventist Church or church members). The station is asking for reports to Adventist World Radio, PO Box 2590, 1114, Lisbon, Portugal.

— Arthur Cushen

KILOHERTZ COMMENT

BURKINA FASO: Formerly Upper Volta, this country continues to be heard in the tropical bands on 4815 kHz. Reception has been noted at 1900 UTC, with a bulletin of news in French for 8 minutes followed by music and spoken programmes, also in French. Burkina Faso broadcasts from the capital, Ouagadougou, and uses 20 kW on 4815 kHz.

NEPAL: Radio Nepal at Kathmandu is using the new frequency of 7165 kHz for an English news bulletin from 1450 to 1502 UTC. The same programme is carried on 5005 kHz but this frequency suffers interference from Radio Malaysia up to 1500 UTC. In the past the English broadcast has been heard at 1502 UTC. Both frequencies now carry Channel 2, a commercial programme in Nepali, and at 1530 UTC a short news bulletin is broadcast followed by a string of commercial announcements and music from Nepal. According to Mr R.S. Karki, 7165 kHz replaces 3230 kHz and the broadcast concludes at 1715 UTC on 5005 and 7165 kHz.

NEW ZEALAND: As from 27 October

when New Zealand moves to Daylight Time, Australian listeners will hear NZ broadcasts one hour earlier. The schedule for Australia and Papua New Guinea is 2245-0045 UTC and 0245-0630 UTC on 15380 kHz and 0930-1115 UTC on 9520 and 11850 kHz. The broadcast to the South Pacific from Wellington is 1800-2015 UTC on 11780 and 15150 kHz, and 2145-0045 UTC and 0245-0630 UTC on 17710 kHz.

VANUATU: At 0900 UTC on 7260 kHz, Port Vila broadcasts a drum beat interval signal followed by news in English. Normally, signals on the alternative frequency of 3945 kHz provide the best reception, but the higher channel has been heard at good strength from as early as 0700 UTC.

This item was contributed by Arthur Cushen, 212 Earn St, Invercargill, New Zealand, who would be pleased to supply additional information on medium and shortwave listening. All times quoted are UTC (GMT) 10 hours behind Sydney time, all frequencies are in kilohertz (kHz).

— Arthur Cushen

ALLEN-BRADLEY 700 SIL RESISTOR NETWORKS PRICE REDUCTION

Now even better value!!

We've closed the gap between the best in quality and competitive pricing.

That's the amazing difference between Allen-Bradley series 700 networks and look-alikes.

We've revolutionised the manufacture of networks - now our consistent quality makes Allen-Bradley the most dependable performance networks available at the price.

Select from a wide range of series 700 Standard circuits and popular ohmic values in 6, 8 or 10 pin packages, 50 resistance values from 22 ohms to 1 megohms.

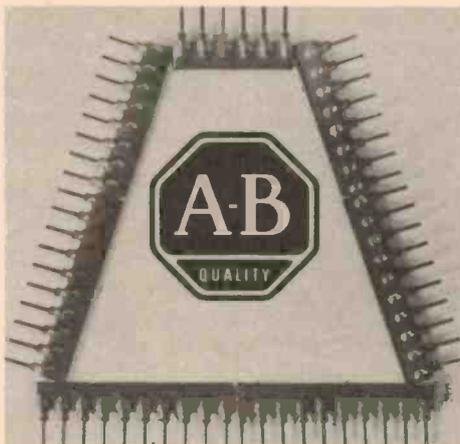

Top marked pin #1 indicator; speeds assembly and inspection even on densely packed boards.

True low-profile; 4.83mm maximum package height specification.

Legible laser marking top and side; permanent, easy to read, and resistant to board washing fluids.

For fast delivery contact your nearest Allen-Bradley office or distributor.

Allen-Bradley - 75 years of cost-effective, innovative electrical component manufacture.



ALLEN-BRADLEY

Design excellence and quality in the best tradition.

VIC. 188 Whitehorse Road, Balwyn, 3103. Ph. 80 6171
N.S.W. 22 Parramatta Road, Lidcombe, 2141. Ph. 648 2652
QLD. 1925 Logan Road, Upper Mt. Gravatt, 4122. Ph. 343 7900
W.A. P.O. Box 23, Subiaco, 6008. Ph. 387 1702
S.A. K. D. Fisher, P.O. Box 170, St. Mary's, 5042. Ph. 277 3288

from the Editors of Consumer Guide . . .

EASY-TO-UNDERSTAND GUIDE TO HOME COMPUTERS

Confused by all these computer terms? This clearly written book from the editors of *Consumer Guide* tells exactly what computers are, how they work and why they are so amazingly useful, all in plain English. Here is all of the information needed to understand and use computers, and even to start programming. A special buying section compares the most popular home computers. This book is your ticket to the computer age! Spiral bound, 96pp.

H0066G

\$8.50



THE BEST VIC/COMMODORE SOFTWARE

Trying to find the most suitable software for personal computers can be frustrating. The editors of *Consumer Guide* have compiled comprehensive reviews of VIC 20 and Commodore 64 programs based on ratings by user groups; further evaluation is given by the editors and Commodore software experts Jim and Ellen Strasma. Each review describes the program's purpose and features, detailing both the good points and bad. Each program has been rated for ease of use, clarity of written and on-screen instructions, and overall performance. The program's price, publisher, format and hardware requirements are also included. The reviews are presented in sets by topic: Word Processing, Business, Home, Education, Networking, Strategy Games, Arcade Games and Programming Aids. Spiral bound, 192pp.

K0052G

\$8.50

THE USER'S GUIDE TO APPLE

The editors of *Consumer Guide* have compiled a thorough introduction to the Apple IIe and II Plus computers, software and peripherals. With colour illustrations and a clearly written text, this reference will guide the newcomer through all phases of learning how to use the computer: From setting the system up, learning what each key does, expanding the system with peripherals, to buying new software. Specific exercises are included for each of the keys. Spiral bound, 80pp.

H0061G

\$8.50



THE USER'S GUIDE TO COMMODORE 64 & VIC 20

The editors of *Consumer Guide* have compiled a thorough introduction to the Commodore 64 and Vic 20 computers, software and peripherals. With colour illustrations and a clearly written text, this reference will guide the newcomer through all phases of learning how to use the computer: From setting the system up, learning what each key does, expanding the system with peripherals, to buying new software. Specific exercises are included for each of the keys. Spiral bound, 80pp.

H0065G

\$8.50

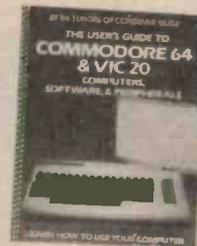

THE BEST APPLE SOFTWARE

Trying to find the most suitable software for personal computers can be frustrating. The editors of *Consumer Guide* have compiled comprehensive reviews of Apple II, II Plus and IIe programs based on ratings by user groups; further evaluation is given by the editors and Apple software expert Roe Adams. Each review describes the program's purpose and features, detailing both the good points and bad. Each program has been rated for ease of use, clarity of written and on-screen instructions, and overall performance. The program's price, publisher, format and hardware requirements are also included. The reviews are presented in sets by topic: Word Processing, Business, Home, Education, Networking, Strategy Games, Arcade Games and Programming Aids. Spiral bound, 160pp.

K0060G

\$8.50

**Order today from Federal Marketing Book Sales —
Simply return the Freepost reply card!**

Postage and packing additional.
Please refer to the reply card.

more Books follow . . .

People who know oscilloscopes, choose KIKUSUI.

Compare the features and you'll see that for our price, they're not worth being without

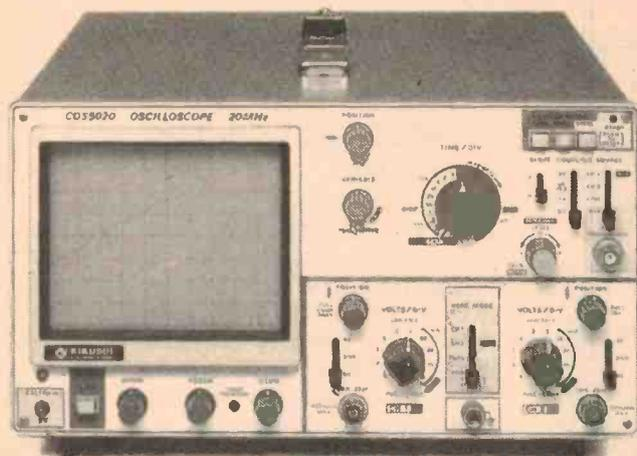

COS-5020 20MHz, 2 Channel

* ON NSW GOVT'S CONTRACT 83/661.

1. Fast 20ns/DIV sweep speed — provides the resolution for timing measurements required of a 20MHz 'scope.
2. Trigger Level Lock — automatically sets trigger level, if selected, so there's no resetting between measurements.
3. Variable Hold off — synchronises complex repetitive signals, like the BURST in a video signal.
4. Linear Auto Focus — maintains clear bright signal traces.
5. Sweep Modes — AUTO, MANUAL and SINGLE SHOT.

2 PROBES
10:1, 1:1
and 2 YEAR
WARRANTY

\$629 ex-tax

\$729.64 incl. tax

Due to currency fluctuations prices are subject to change without notice.

KIKUSUI 'SCOPES FROM 20 MHz TO 150MHz and DIGITAL STORAGE 'SCOPES TO 4K RAM.



EMONA INSTRUMENTS

Division of EMONA ENTERPRISES PTY LTD

1st Floor
720 George St
Sydney 2000.
Phone: (02) 212 4599

All correspondence to:
P.O. Box K720
Haymarket 2000.
Telex: AA74500 EMONA

ALSO AVAILABLE FROM:

- NSW Davred Electronics, Sydney. Phone 267 1385.
Geoff Wood Electronics Pty Ltd, Rozelle. Phone 810 6845.
VIC Radio Parts Group, Melbourne, Phone 329 7888.
QLD Baltec Systems Pty Ltd, Brisbane. Phone 369 5900.
Nortek, Townsville. Phone 798 600.
WA Hincro Engineering Pty Ltd, Perth. Phone 381 4477.

- ACT Electronic Components Pty Ltd, Fyshwick. Phone 80 4654.
SA Int's Communication Systems Pty Ltd, Port Adelaide, Phone 47 3688.
TAS George Harvey Electronics, Hobart. Phone 34 2233.
George Harvey Electronics, Launceston. Phone 31 6533.

THE MONEY SAVERS

DPDT HI-QUALITY
ROCKER SWITCH
20¢ ea 100 for \$15
NORMALLY 50¢ ea.

SPEAKER BOX SALE!
Sorry, \$6 Shop sales only!
620mm x 350mm x 225mm

DISCO STROBE
0-12 flashes per second!
\$25 ea
Ideal for parties, theatre, dances etc. 240v

ALARM CONTROL PANEL
4 INPUTS - N.O. and N.C. instant or delay.
6 LED STATUS INDICATORS
Entry and Reset ADJUSTABLE DEL.
Inbuilt 24HR PANIC or FIRE alarm circuit.

NEW HANDY HEATSHRINK PAK 14x100mm pcs.
Just slip over solder joint and heat - plastic shrinks to form a tight seal. **ASST. SIZES \$3 EA PAK**

HUGE REDUCTION!
VIDEO ENHANCER and STABILIZER
DETAIL ENHANCER \$35
SALE \$49 THE PAIR
IMAGE STABILIZER \$29
OVER 50% OFF!

INFRA-RED BURGLAR DETECTOR!
Passive infra-red is ideal for all home, office and shop alarms - LED indicator, upto 12m range, N.O./N.C. 12vac
\$89 ea

FANS
5" 115VAC OR 220VAC
\$10 ea
EX-COMPUTER

NEW, IMPROVED MODEL!
Dry cell or rechargeable 12v battery operation, heavy duty lockable steel cabinet, inbuilt siren and DC 12v power outputs. **IDEAL FOR HOMES, SHOPS, OFFICES!**
\$119

12V 20 AMPS Transformer
Input: 0-240v
Output: 8v+8v or 10v+10v
2 WINDINGS AT 20A
Ideal for 13.5v CB or Amateur power supply
\$39 ea

ALARM or EMERGENCY!!!
STROBE FLASHER
ORANGE, BLUE, RED
12V WERE \$28-70
\$21

RADIO CONTROL
REMOTE SWITCH
CAR alarm model with 2 transmitters... \$95
Single OR Dual CHANNEL for home, alarms, garage doors, industrial control etc. These have extended range to 100metres, 12,000 programmable codes.
1CH + TRANSMITTER... \$115
Extra transmitters, each... \$32
2CH + TRANSMITTER... \$125
Extra transmitters, each... \$40

PARTS VALUE PACKS
LUCKY-DIP ASSORTMENTS!
500 1/2W RESISTORS
200 1W RESISTORS
100 CERAMIC CAPS
30 GREENCAPS
45 ELECTROLYTICS
20 POTENTIOMETERS
25 PRESET POTS
30 MICA CAPS
40 RADIO/TV KNOBS
20 VARIOUS FUSES
12 SWITCHES
50 TAG STRIPS

FUJI FILM FLOPPY DISK
SPECIAL INTRODUCTORY OFFER!
Size Type Format Tax Free Tax Paid
5 1/4" MD1D SSDD \$32.00 \$36.00
5 1/4" MD2D DSDD \$42.00 \$48.00
5 1/4" MD2H DSQD \$73.00 \$82.00
8" FD1S SSDD \$49.00 \$56.00
8" FD2S DSDD \$51.00 \$58.00
8" FD2D DSDD \$54.00 \$61.00
3 1/2" MF1D SSDD \$66.00 \$75.00
3 1/2" MF2D DSDD \$89.00 \$99.00
LIFETIME GUARANTEE!
Certified 100% error-free.
FREE BUY 2 PACK, receive free 5 1/8" disc cleaner
FREE BUY 3 PACKS, receive free 5 1/8" plastic disk box!

FANTASTIC! CAR ALARM
ULTRASONIC + RADIO KEY.
Interior motion detector, current, door sensing, panic alarm button, inbuilt siren, delay, reset!
ONLY \$159

EX-COMPUTER CAPS
100,000uf 10v 33,000uf 40v
30,000uf 15v 20,000uf 45v
25,000uf 20v 10,000uf 50v
15,000uf 25v 22,000uf 50v
50,000uf 25v 20,000uf 55v
20,000uf 30v All tested EA and g'testd \$5

JACKPOT
Box No 5
Our biggest box ever! Nearly 5kgm of parts for electronic hobbyists. A little bit of everything - VALUED AT \$70!
\$15

PRE-PAK electronics p/l

1a WEST ST. LEWISHAM, NSW

569-9797
24 HR PHONE ORDER SERVICE

Phone or mail order
BANKCARD accepted

BOOKS OF SPECIAL INTEREST

electronics textbooks

ELEMENTS OF ELECTRONICS- BOOK 1

This five book series is an introduction to modern electronics. All of the necessary mathematics is introduced and explained as required. The emphasis is on understanding concepts rather than digressing over the whole field. The author anticipates difficulties the beginner may have and explains them as they occur. BOOK 1 covers all of the fundamental theory necessary to understand simple electronic circuits and components. 209pp.

A0003B \$9.95

ELEMENTS OF ELECTRONICS- BOOK 2

See Book 1: Covers alternating current theory. 216pp.

A0004B \$9.95

ELEMENTS OF ELECTRONICS- BOOK 3

See Book 1: Covers semiconductor technology and introduces transistors and ICs. 204pp.

A0005B \$9.95

BASIC ELECTRICITY/ELECTRONICS

Volume 1 gives a thorough theoretical and practical background to the overall theory and practical aspects of electricity and electronics. Volume 2 builds from the background into a detailed coverage of AC and DC circuits including series and parallel circuits, electro-magnetism, resistance, capacitance and inductance with explanations of the associated calculations. Volume 4 explains construction, operation and usage of electronic test instruments with full details on analogue and digital multimeters, vacuum-tube voltmeters, oscilloscopes, tube testers and more: Enough to equip a workshop. Volume 5 gives simple and clear explanations of the operating principles of motors and generators and builds into detailed discussions of their workings.

A0008H Vol 1, 320pp. \$15.95
A0009H Vol 2, 318pp. \$15.95
A0011H Vol 4, 396pp. \$15.95
A0012H Vol 5, 240pp. \$15.95

reference and data handbooks

PRACTICAL ELECTRONIC CALCULATIONS AND FORMULAE

For the practical person's workbench. Bridges the gap between practical theory and cut-and-dried methods which work but leave the experimenter unfulfilled. There's a strong practical bias and higher maths are avoided where possible. 249pp.

B0027B \$9.95

INTERNATIONAL DIODE EQUIVALENTS GUIDE

Includes zener diodes, LEDs, diacs, triacs, thyristors, OCIs; photo, display, and simple rectifier diodes. 130pp.

B0339B \$6.95

Prices subject to change without notice.

Stock of some titles may be limited.

electronics for beginners

BEGINNER'S GUIDE TO ELECTRONIC PROJECTS

This guide enables the complete beginner to tackle the practical side of electronics so that the projects featured regularly in popular magazines can be approached with confidence. The basics are covered in detail using practical examples in the form of simple projects. 107pp.

C0030B \$6.95

SOLID STATE SHORTWAVE RECEIVERS FOR BEGINNERS

Details the design and construction of several solid state shortwave receivers giving a high level of performance yet utilising few components. 93pp.

C0044B \$5.95

circuit techniques and design

REMOTE CONTROL PROJECTS

Primarily for the enthusiast who wishes to experiment with remote control. Full explanations of the how the circuits work are given and many of the designs can be adapted to circuits that have been published elsewhere. Covers remote control by ultra-sound and infra-red as well as radio control. 164pp.

D0046B \$6.95

HOW TO DESIGN ELECTRONIC PROJECTS

Tackles the problem of combining and integrating components into a complete working project with the minimum of trial and error and without advanced mathematics. Guides the reader through examples with circuit analysis, possible solutions and practical designs including component values. 101pp.

E0082B \$6.55

test equipment and fault finding

TROUBLESHOOTING WITH THE OSCILLOSCOPE

Excellent for the professional service technician or serious hobbyist. It combines step by step procedures for using the 'scope with the specific nuts and bolts of television receiver troubleshooting. 92pp.

F0121P \$17.95

ELECTRONIC TROUBLESHOOTING HANDBOOK

This workbench guide shows you how to pinpoint trouble in minutes, how to test almost anything electronic and how to get the most out of low-cost test equipment. 215pp.

F0257H \$13.95

*Postage and packing additional:
Please refer to reply card for charges.*

USE OF THE DUAL-TRACE OSCILLOSCOPE

This programmed text breaks down the process of operating a 'scope into a series of logical steps. It starts with the deflection of the electron beam and continues through the proper use of the triggering controls to measure the phase difference between two waveforms.

F0259H \$43.50

electronic music and audio/video

MODERN RECORDING TECHNIQUES

Explains the equipment, controls and techniques found in a modern recording studio. Describes how to use these creatively and correctly to produce a specific result. Numerous photographs, diagrams and charts. 367pp.

G0128P \$24.95

THE MUSICIAN AND THE MICRO

A straightforward and practical guide for keen musicians, teachers and those who work in the music industry. It covers the exciting world of microprocessor applications and computerised musical instruments. 192pp.

G0280D \$9.95

AUDIO

A theoretical study of sound waves and acoustical quantities which leads into a study of hearing and room acoustics. A discussion of microphones and loudspeakers is developed into sections on amplifiers and recordings, covers digital as well as magnetic and disc recording. 308pp.

G0332B \$7.55

SINGLE-CAMERA VIDEO PRODUCTION

Step by step diagrams and illustrations show you how to produce low-budget, high quality video programs using only one camera. There are chapters on audio, lighting, shooting, editing, graphics and set design. 241pp.

G0379H \$25.25

computers for beginners

COMPUTER TERMINOLOGY EXPLAINED

Concise explains the most common terms encountered by the home computer enthusiast as well as many of those used with mini- and mainframe computers. Includes tables of ASCII codes and BASIC control codes. 81pp.

H0143B \$5.95

ALMOST EVERYBODY'S PERSONAL COMPUTER BOOK

Written for the computing beginner to break the enormous barrier of jargon and mystique that seems to surround computers. With a highly readable approach, the author introduces the basic concepts and develops them into a general discussion on personal computers including choosing and caring for a PC. Also offers an introduction to BASIC programming. 160pp.

H0144Z \$8.95

ORDER TODAY — Simply return the Freepost reply card!

FREE

TOOL KIT

**WITH EVERY
IRON BOUGHT
THIS MONTH.**



\$19.70
plus tax

**SCOPE
COMMODORE
Model PH20
20W - 240V**

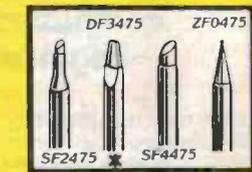

**4 INTERCHANGEABLE
TIPS** - let you match the tip's
heat transfer rate to each job.
All 370°C idling temp.

1. Aircooled Grip
2. Interchangeable Tips
3. Long Life iron plated tips
(4 shapes available)
4. 370° C Tip (Idling)
5. Safety Stand Available

IAN J. TRUSCOTT
ELECTRONICS

30 LACEY STREET,
(Cnr. Windsor Street)
CROYDON, 3136
Telephone: (03) 723-3860



TO OUR READERS . . .

computing software

APPLE IIe PROGRAMMER'S REFERENCE GUIDE

Has a logical approach that gives the beginner general rules and a survey of BASIC statements, commands and functions. Those with some programming experience will learn the finer points of text formatting, color graphics and advanced disk operations. The more advanced programmer will find an invaluable reference in the memory map descriptions and 6502 programming techniques. 366pp.

K0043P \$29.95

8088 ASSEMBLER LANGUAGE PROGRAMMING: THE IBM PC

This second edition includes the PC/XT and covers the new versions of DOS and the introduction of the double-sided disk drives and the complications of diskette compatibility. This is a thorough Introduction to assembly language programming for the IBM PC for fast program execution and close control. Sample programs and a complete instruction set are included. 268pp.

K0050P \$24.95

WILDCARDS 4

No tips, techniques or theory in this volume: It's mainly quality games with PCG graphics- games of strategy and games of fast reflexes, many of them taking full advantage of colour graphics. From simple Boxes (not so simple!) to Radio with complex scenery: This is a book that teaches the fun way. 109pp.

K0024P \$15.95

INSTANT PROGRAMMING ON YOUR SEGA SC3000 COMPUTER

Spiral-bound for easy use, this is THE Sega SC3000 beginner's book! In carefully explained, easy to follow steps, it covers the function of each key and all of the commands needed for super fast mastery of BASIC programming. This is a book for do-ers: The second part of the book teaches the real art of programming with plenty of examples and subroutines. 84pp.

K0051P \$12.95

WILDCARDS: VOLUME THREE

This collection of programs, tips and techniques for all models of Applied Technology's Microbee personal computer takes a 'hands-on' approach. Small business applications are given, as well as utilities and graphics, and there is a machine language game tutorial included. 122pp.

K0054P \$15.95

DISCOVERING KNOWLEDGEMAN

According to prestigious Byte magazine, KnowledgeMan may be the most powerful relational DBMS currently available for microprocessors- and this is a powerful introduction! After a general overview, data management and spreadsheet capabilities are examined in eight sets of detailed lessons structured to give maximum learning benefits. 342pp.

K0086P \$29.95

AN INTRODUCTION TO PROGRAMMING THE BBC MODEL B MICRO

Teaches the use of BBC BASIC by guiding the reader through BASIC instructions and functions one at a time, building programs in a logical manner with increasing complexity. 134pp.

K0174B \$5.95

New Books from
Consumer Guide.
See page 103!

STARTING FORTH

This clear and complete guide to FORTH, covers fundamental principles and then a full set of high-level commands. It concludes with advanced techniques and style. 348pp.

K0177H \$37.95

AN INTRODUCTION TO 6502 MACHINE CODE

Starts with a general background to microprocessing and then details all of the legal 6502 instructions. Also covers the use of address modes and gives machine specific listings and sample programs. 107pp.

K0178 \$6.55

AN INTRODUCTION TO Z80 MACHINE CODE

Starts with a general background to microprocessing and then details the full set of Z80/Z80A instructions. Also covers the use of address modes and gives machine specific listings and sample programs. 107pp.

K0180B \$6.55

APPLE II ASSEMBLY LANGUAGE

Teaches assembly language programming at the beginning level: No prior knowledge of 6502 assembly language is needed. Includes hands-on exercises and experiments with both software and hardware. Provides interfacing circuits and programs that can be used on the Apple II without modification. 334pp.

A0195P \$23.95

VISICALC

This quick and easy reference to the features of the VisiCalc spreadsheet package covers the commands and facilities of the latest available version and explains the variations with the operating features of the Commodore range, Apple II and IBM PC. VisiCalc aims, commands, and functions are all given detailed coverage in their own sections. One of the well-known Pitman Computer Handbooks. 86pp.

L0023P \$7.95

amateur radio dx, communications

25 SIMPLE AMATEUR BAND AERIALS

Describes how to build 25 amateur band aerials that are simple and inexpensive to construct and perform well. Projects range from the simple dipole up to a mini-rhombic. 63pp.

N0286B \$6.75

25 SIMPLE SHORTWAVE BROADCAST BAND AERIALS

Describes concisely the design and construction of simple and inexpensive aerials that perform well: from simple dipole to end-fire arrays. Includes dimensions and other data for spacing and cutting phasing lengths. 63pp.

N0362B \$5.95

Postage and packing additional:
Please refer to reply card for charges.

LIMITED
SPECIAL
OFFER!

1/3 off

Electronics Today SUBSCRIPTIONS

POST FREE
No postage stamp required
if posted in Australia

FREEPOST No. 4
The Federal Publishing Company
PO Box 227
WATERLOO, NSW 2017

**PAY for 8
RECEIVE
all 12**

issues in a year's
subscription
to
**Electronics
Today**

Electronics Today

BOOK SALES

POSTAGE AND HANDLING CHARGES	ORDER VALUE	ADD	
	Up to \$9.99	\$2.25	For airmail to Papua New Guinea, New Zealand, Oceania and Southeast Asia, add \$6.00 to these charges.
	\$10 to \$19.99	\$4.25	
	\$20 to \$39.99	\$5.25	
	\$40 to \$99.99	\$6.25	
	\$100 and over	\$7.25	

BOOK TITLE	BOOK NUMBER	QTY	PRICE TOTAL

Please tick box to indicate method of payment:

Cheque*/Money Order *Please make payable to the Federal Publishing Company Pty. Ltd.
 Put your cheque or money order in an envelope with this card. Mark the envelope FREEPOST No. 4 and send it to the address overleaf. No postage stamp required in Australia.
 Mastercard American Express Bankcard Tick
 Credit Card No.
(Unsigned orders cannot be accepted)

Card Expiry Date..... Signature.....
 Allow up to 6 weeks for delivery.

Total price of books \$.....
 Add postage and handling \$.....
TOTAL \$.....

NAME:.....
 ADDRESS:.....
 POSTCODE:.....

Electronics Today

BOOK SALES

POSTAGE AND HANDLING CHARGES	ORDER VALUE	ADD	
	Up to \$9.99	\$2.25	For airmail to Papua New Guinea, New Zealand, Oceania and Southeast Asia, add \$6.00 to these charges.
	\$10 to \$19.99	\$4.25	
	\$20 to \$39.99	\$5.25	
	\$40 to \$99.99	\$6.25	
	\$100 and over	\$7.25	

BOOK TITLE	BOOK NUMBER	QTY	PRICE TOTAL

Please tick box to indicate method of payment:

Cheque*/Money Order *Please make payable to the Federal Publishing Company Pty. Ltd.
 Put your cheque or money order in an envelope with this card. Mark the envelope FREEPOST No. 4 and send it to the address overleaf. No postage stamp required in Australia.
 Mastercard American Express Bankcard Tick
 Credit Card No.
(Unsigned orders cannot be accepted)

Card Expiry Date..... Signature.....
 Allow up to 6 weeks for delivery.

Total price of books \$.....
 Add postage and handling \$.....
TOTAL \$.....

NAME:.....
 ADDRESS:.....
 POSTCODE:.....

Start saving, send
the FREEPOST Card
today!

Electronics Today

Help us to meet your interests in ETI.

Please tick the appropriate boxes

Are you most interested in:

- New products/equipment
- Radio/communications
- Computer hardware
- Industrial Control
- Computer software
- Video/television
- Audio/hifi
- Circuit design

Which of these best describes you?

- Engineer/designer
- Interested consumer
- Technician
- Hobbyist
- Manager

Thank you

SUBSCRIPTION OFFER

1/3

LIMITED SPECIAL OFFER!

Send me 12 issues of ETI at 1/3 off the newstand price. I only pay for 8 issues! That's just \$22 for 12.

NAME:

ADDRESS:

POSTCODE:

Cheque*/Money Order * Please make payable to the Federal Publishing Company Pty. Ltd. Put your cheque or money order in an envelope with this card. Mark the envelope FREEPOST No. 4 and send it to the address overleaf. No postage stamp required in Australia. Overseas rates on application.

Mastercard American Express Bankcard Tick

Credit Card No.

Card Expiry Date: Signature:

(Unsigned orders cannot be accepted)

Allow up to 6 weeks for delivery of first issue.

Card valid to 31/10/85.

Electronics Today BOOK SALES

POST FREE
No postage stamp required
if posted in Australia

FREEPOST No. 4
The Federal Publishing Company
PO Box 227
WATERLOO, NSW 2017

Electronics Today BOOK SALES

POST FREE
No postage stamp required
if posted in Australia

FREEPOST No. 4
The Federal Publishing Company
PO Box 227
WATERLOO, NSW 2017

Need to know more about an advertised product?



Try our FREE READER INFORMATION SERVICE, designed to make it easy for you to find out more. For a prompt reply, send the FREEPOST Card today!



Electronics Today

Electronics Today

Subscribe now . . .



1/3 off 1/3 off 1/3 off 1/3 off 1/3 off

. . . at 1/3 off the normal
Electronics Today
 is Australia's dynamic electronics magazine. Keep informed and busy every month:

- ★ read informative features
- ★ assess our product reviews
- ★ projects for every level of hobbyist
- ★ update with news and ideas

Take advantage of this offer now . . .

- ★ Complete either the card opposite or the coupon below
- ★ Detach and post free from anywhere in Australia
- ★ Don't delay

retail price! —
save \$11.00
on a year's subscription!

Better still save \$22
on a two year subscription and guard against price increases until 1987!

Subscribe now at 1/3 off the normal price

Yes, please send me 24 issues (2 years) of Electronics Today at 1/3 off the normal newsstand price. I'll save \$22.00 and guard against price rises until 1987!!

OR Yes, please send me 12 issues (1 year) of Electronics Today at 1/3 off the normal newsstand price. I'll save \$11.00!

Name _____

Address _____

Postcode _____

Please tick payment you select: (Please do not send cash)

- Bankcard Mastercard American Express
 Cheque/money order*

*Enclose cheque/money order with this coupon in an envelope and address to: Freepost No 4, The Federal Publishing Company Pty. Ltd., PO Box 227, Waterloo, 2017. No postage stamp is required if posted in Australia.

Card No. _____
 Expiry Date _____/198__

Signature _____
Unsigned orders cannot be accepted

Please allow up to 6 weeks for delivery of your first issue.

Coupon valid until 31/12/85.

Help us to meet your interests in ETI
 Please tick the appropriate boxes.

Are you most interested in:

- New products/equipment
- Radio/communications
- Computer hardware
- Industrial Control
- Computer software
- Video/television
- Audio/hifi
- Circuit design

Which of these best describes you?

- Engineer/designer
- Interested consumer
- Technician
- Hobbyist
- Manager
- Student

GOOD THINGS COME IN SMALL PACKAGES?

—IC-735 HF transceiver and general coverage receiver

Unpacking the Icom IC-735 with two or three pairs of extra unnecessary hands was an experience in itself. "Isn't it small! Isn't it light — just the right thing for the boat!" Unanimous exclamations fully in keeping with Icom's latest creation — amateur transceiver and general coverage receiver.

Peter D. Williams

THE IC-735 COULD be aptly renamed: IC-735 "SP" — suitcase portable! After all, with dimensions of 241 mm (9.5 inches) wide, 94 mm (3.5 inches) high and 239 mm (9.5 inches) deep embracing a whole 5 kg of mass, one could easily take the '735 on an interstate trip if the accompanying PS55 ac power supply was no problem. Yes, I am sorry to say you need a power supply if operation on ac is necessary — Icom hasn't yet been able to package a power supply into a box this size.

These space considerations raise the interesting question of why manufacturers appear to equate size with performance and subsequent market acceptance. A box (transceiver) of this size is obviously a bonus and eminently desirable, when operating mobile — yet how many operators *do* make their contacts whilst mobile? 'Smallest is best' may well apply under these conditions but even a casual listen around would indicate that the majority of contacts are made from home where, usually, sufficient space is no object.

Some ergonomic considerations are compromised if manufacturers adopt the 'smallest is best' approach. Maybe amateurs in Japan or Europe are conditioned to 'petite' boxes but personally, the search for smallness does not result in a convincing sales point for me unless I have an application for that benefit. The advantage of small volume is recognised but even so, operating mobile

on 2 metres is difficult enough without all the drama associated with tuning an HF rig.

Icom of course is no newcomer to the production of compact equipment. This rig follows the lead given by its predecessors, the IC701, IC720, and more recently, the IC730 — power input is still 200 watts PEP (peak envelope power) on SSB and 200 watts input on FM. Power output can be controlled continuously from 10 watts to maximum. It is interesting to note that there are no precautions listed in the manual against continuous full power output on RTTY (radio teletype). No doubt early problems with final transistors have been cured when operating at full output, and in any event, the now well proven 2SC2904 can be relied upon, as the final assembly is cooled by a squirrel type fan which appears to be very efficient, and somewhat better than the conventional muffin type fan. The squirrel fanblower is extremely quiet and takes air from 'all over' the internals, and exhausts out the back. It has a three stage boost which turns on at the beginning of a transmission, speeds up when the finals reach 50°C, and at 90°C runs 'flat chat'.

Well how does it seem? The rig covers 1.8 through to 30 MHz on the appropriate amateur bands although there is a generous 'spill over' on transmit on most bands. For example, the 14 MHz band starts transmitting at 13.9 MHz and finishes at 14.4999 MHz. Icom recognises that fact and points

out in the manual that it is the operator's responsibility to follow the pertinent government radio regulations.

Construction and design

The construction is of the usual Icom quality. A feature not seen before in amateur rigs is the diecast box which contains and completely shields the final transmitter stages as well as the low pass filter and keyer. This diecast box also acts as a heatsink and with the fan, keeps everything very cool. A not so obvious advantage until you look for it is that any external heatsinks with protruding fins are eliminated, which makes installation and mounting problems much easier to solve.

Before leaving the shielded/heatsink box assembly, it is worth recording that the optional CW keyer module uses the Curtis 8044B chip from the USA — our review sample had the keyer installed. Curtis has been a specialist chip manufacturer for some time, especially in the area of keyers; it has designed a circuit and IC to include contact debouncing, protection against rf, dot memory and weight control.

The keying speed can be changed between five and 45 words per minute by using the MIC GAIN/SPEED CONTROL on the switch panel. To the serious CW user, the features appear excellent — I say "appear" as opportunity was not taken to exercise the CW function.

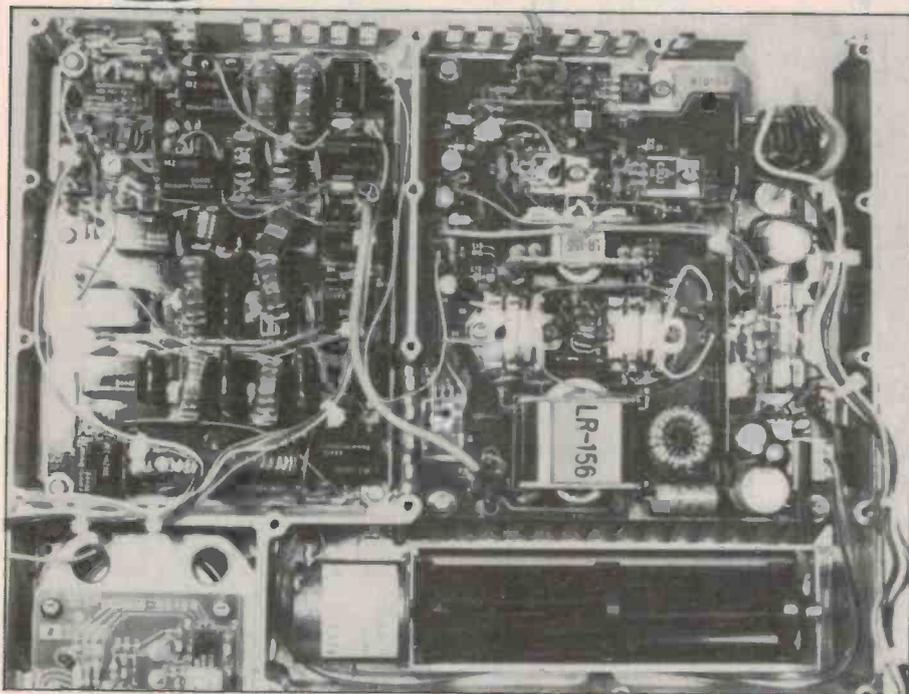
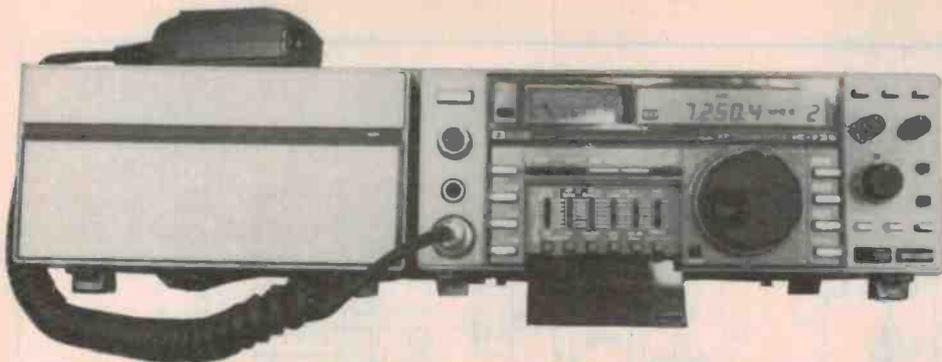

Interior view of the diecast chassis. Final amplifier is on the right with a squirrel cage blower. Low pass filter assembly is on the left partly showing the electronic keyer assembly.

Internal layout

The circuit is mounted on three main boards with all external connections made via plugs to the external harness, thus making board removal simple and clean when servicing. Circuit boards are single sided and the track layout printed on the component side allows for ready identification of components and circuit tracing. This is a great improvement over data supplied with earlier Icom models where a separate sheet, as distinct from the schematic, purported to show the board layout. As improvements in circuit design were made during the production life of the rig, the schematic, board layout and circuit board under investigation did not always agree. This arrangement is so much better and is to be recommended. Manufacturers of commercial and professional test equipment take note!

Front panel — controls and functions

Probably the most conspicuous new feature is the LCD display for frequency read-out — fluorescent tube displays are now out apparently. A pleasant green backlighting enhances the effect and shows, as appropriate, the mode, memory channel, scan, VFO A or B, and whether in transmit or receive.

The VFO knob rotates smoothly with a

finger hole big enough for western fingers. Frequency changes are in 10 Hz steps for fine tuning but there is an unusual feature in that the faster the knob is turned, the steps of frequency increment automatically increase. This makes it very useful when wanting to move from one part of a band to another fairly rapidly. Band changing is also done when the HAM button immediately alongside it is depressed. This tuning is worthy of comment in a little detail.

Tuning, HAM bands/general coverage receiver

Alongside the tuning knob are four push-buttons arranged vertically — uppermost is kHz, then MHz, HAM and at the bottom SCAN. To select an amateur band, say 80 metre or 3.5 MHz you depress the HAM button and rotate the tuning knob until 3.5 appears on the LCD display. All amateur bands will be displayed consecutively as the tuning knob is rotated. You will also notice that mode, the VFO in use and any memory channel number are also displayed on the LCD.

To tune across the 3.5 MHz band you have to depress the HAM button again and rotating the tuning knob will then tune in 10 Hz steps. If a more rapid excursion is re-

quired depress the kHz button and tuning takes place in 1 kHz steps. Fine tuning can be effected by depressing the kHz button *again* and you then get the 10 Hz steps. However as mentioned earlier, the tuning rate increases the faster you turn the dial so finger and wrist exercises need not be as arduous nor as prolonged as the explanation given might suggest.

Of course, there will be some kHz displayed as well unless, coincidentally, 3.500.0 has been dialled up previously. Any previously dialled up frequency will remain in the memory even after turn off and selecting the desired band requires a little manoeuvring of buttons and knobs. Nevertheless, I would concede the point that with most new techniques, operator familiarity will probably enable the user to cope.

General coverage receiving is somewhat similar except that you use the MHz button to select the MHz segment of interest, and then depress the kHz button to tune across the 1 MHz band of interest.

Transmitting on anything other than amateur band is inhibited when tuning outside amateur frequencies, by having programmed frequency limits. Inspection of the schematic shows that aspiring pirates had better have plenty of booty to fund circuit changes — in short no hope of making changes.

Modes

Modes are selected automatically when band selection is made. Bands below and including 7 MHz are LSB whilst 10 MHz band and above get USB. However the choice is yours on any band by depressing the SSB button where the other mode appears.

VFO A/B selection

A dual VFO is used for either transmitting and/or receiving. A frequency can be set in one VFO and the other can be used to search up and down the band of interest. Pressing the VFO switch returns you to the other VFO frequency.

Both mode and frequency can be stored in each VFO and cross mode or even cross band contacts can be made.

The switch labelled SPLIT gives transmit on one frequency, VFO A, and receive on another, VFO B. It was pleasing to note that RIT (receiver incremental tuning) is provided, as another high priced transceiver omits this function and you have to use one of the VFOs, which is a nuisance. RIT is a most useful function as it enables tuning of an SSB signal for audio without changing the transmitting frequency.

Memories/scanning

In keeping with market trends, twelve programmable memories are provided to store mode and frequency.

It is possible to scan what you have put in memory — frequencies and/or modes. For example, you may want to selectively monitor memory channels that save SSB, AM or FM. When scanning between frequency ▶

Block diagram.

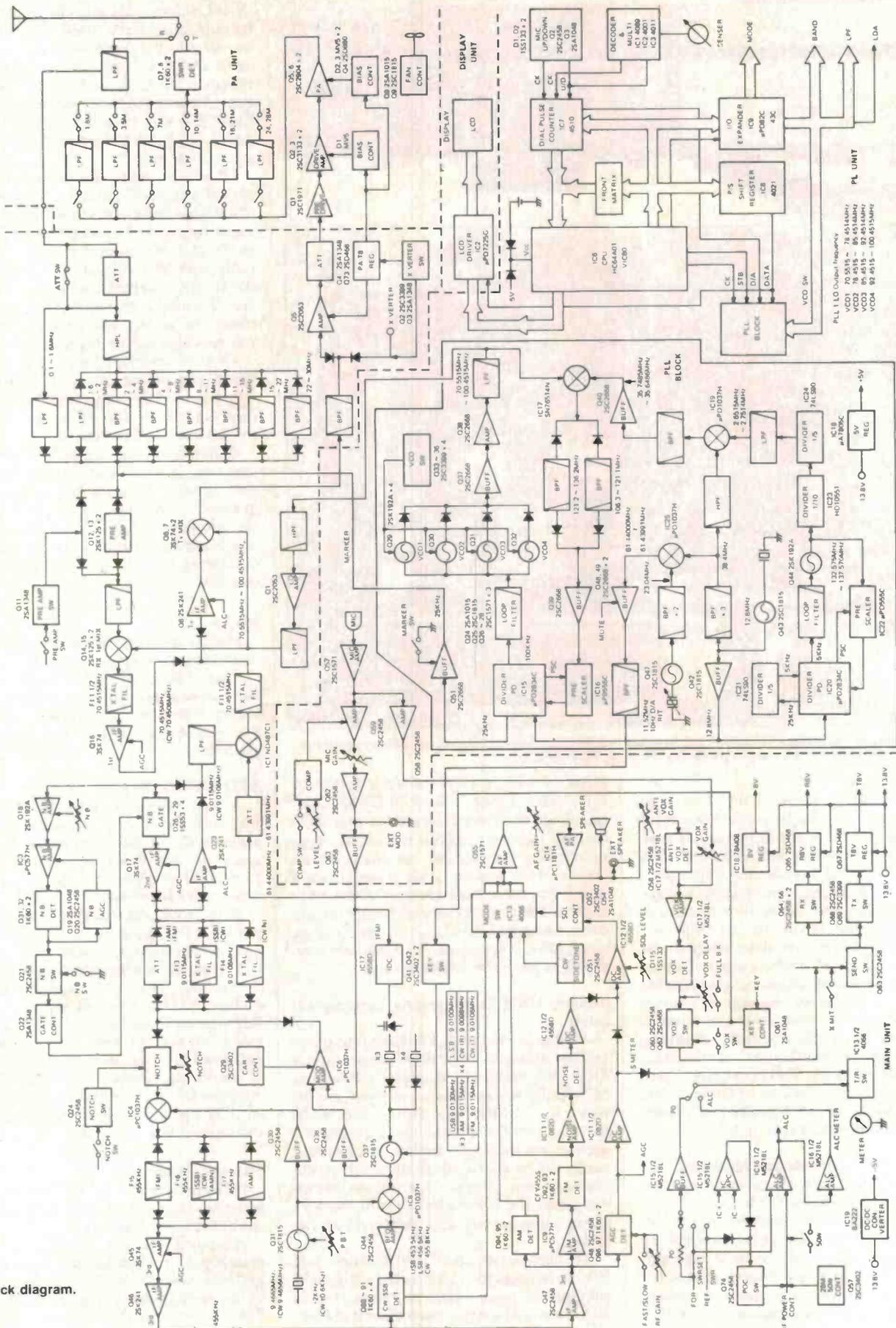

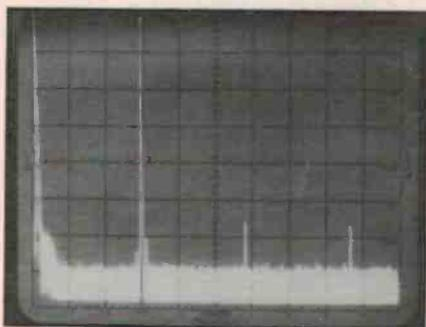

Harmonics. 5 MHz/div, 30 kHz resolution, 10 dB/div. Frequency of carrier is 142 MHz and harmonics are 56 dB down from carrier.

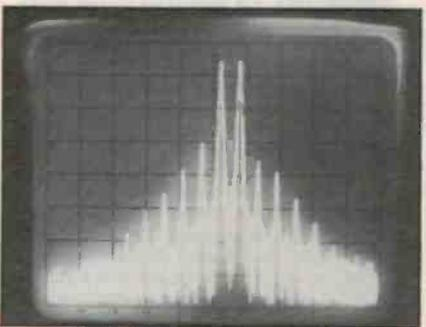

Intermodulation. 2 kHz/div, 100 Hz resolution, 100 Hz video filter. Tones used 900 Hz and 2000 Hz. Level set with ALC half scale. Third order products 30 dB below carrier. Frequency 14.2 MHz.

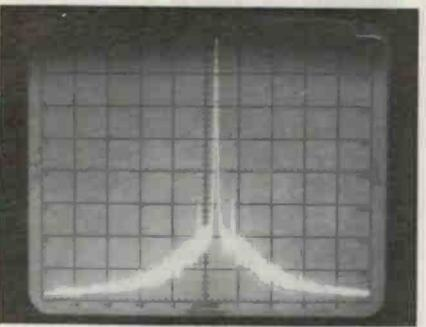

Spurious. 5 kHz/div, 100 Hz resolution, 10 dB/div vertically. Note spurs 2.5 kHz away from carrier. Frequency 14.2 MHz and power output 86 W.

limits memory channels 11 and 12 are used as the lower and upper limits, and with the squelch control on to mute the receiver, scanning will take place in either 100 Hz or 1 kHz steps depending on whether you have depressed the tuning rate switch. Dwell time or the time the receiver remains on a received signal is around 10 seconds. Thereafter the scan is resumed and when the upper scan frequency is reached, the cycle recommences from the lower limit frequency.

All in all quite a versatile combination of memory and scan function.

Front panel

Front panel layout is quite good. Little used functions are hidden, recessed behind a plastic cover on the front panel: centre left and conceal noise blanker level, rf, gain rf power, VOX gain, delay and mic gain.

Some of the labels are hidden when the cover is hinged down, which is a nuisance. Borrowing from established audio practice these controls are slider potentiometers and again, it remains to be seen if they become popular. Pushbutton switches of other little used or infrequently operated controls include AM/CW bandwidth, meter ALC/PO, VOX ON/OFF and two switches controlling CW break in and electronic keying speed for CW.

The built-in preamp ON/OFF switch and AGC ON/OFF switch are mounted above this recess. With the exception of rf gain control I would agree with the selection, but even so, adjustment is not easy because of the smallness of the control.

Vertically the left hand side of the front panel has a power switch, audio gain and squelch, phone and microphone plugs. The meter indicates relative power outputs, and the SWR (standing wave ratio) of the power system. Mode switches (all pushbutton) are conveniently located and labelled SSB, CW, AM, and FM.

The right hand side of the front panel carries the controls associated with frequency, VFO selection, scanning and memory functions.

Rear panel

Accessory connectors, are available for phone patch and RTTY together with a control connector for external and optional automatic antenna tuners, linear amplifier etc.

One pair of antenna connectors is normally joined together but when the link is removed, this enables a separate antenna to be used, especially if listening to frequencies other than amateur is your interest. Other connectors include key jack for CW, ACC jack for automatic level control from a linear amplifier with input voltage in the range of 0 to 4 volts.

As the rig has a speech compressor a level control is fitted and when switched in gives a preset circuit gain of 10 dB.

One control not seen in other equipment is a microphone/audio tone control; judging from some of the gravel voices on the bands, such assistance would be appreciated. More importantly, as speech intelligibility via SSB requires more emphasis on frequencies between 500 and 1500 Hz, tailoring the response can only improve the situation.

Remote control jack

This facility has been singled out as worthy of special attention. The handbook casually mentions the remote control jack on the rear panel to remotely operate the transceiver functions. Of course remote, and personal computer operation is nothing new and Icom has had computer interface facilities available with some of its other transceivers such as the IC751, IC740 and

IC745. There is no information given in the manual about protocols, or interface requirements except to say that serial RS232 would be used. Icom has yet to release interface requirements but it would be safe to assume that the previously available Icom CT-10 interface could be pressed into service. PCs listed in the literature have been the Sharp range PC-8001, PC-8201, PC-6001 together with the Tandy TRS-80 and the Commodore VIC-20.

Technical evaluation

How do we know when we have a good one? In the August issue of ETI we produced a set of standard specifications for VHF/UHF transceivers which you are advised to refer to. With HF, our standards are a little different and take into account some factors that do not have much effect at VHF/UHF. I refer particularly to the receiver which at VHF does not suffer from atmospheric noise, especially if the mode is FM as noise on FM is cancelled in the limiter stages.

On HF, atmospheric noise is the limiting factor as far as usable sensitivity is concerned, and while laboratory tests may show sensitivities of a fraction of a microvolt, in practice, this is of academic interest for the reason given.

More important are reciprocal mixing, dynamic range and intermodulation figures, because as you will appreciate, strong interfering signals on or adjacent to your frequency can have a receiver show its true colours when trying to resolve the wanted signal. Probably reciprocal mixing figures are more important than intermod distortion figures because poor reciprocal mixing figures reduce the dynamic range of a receiver. I don't want to turn this point into an academic discussion, but one should be aware that if the local oscillator from the radio's synthesizer does not have low phase noise or low noise sidebands, you can have mixing of the incoming signals with the noise sidebands to provide an output at the IF (intermediate frequency). An otherwise excellent receiver may be rendered useless if it uses a 'noisy' local oscillator synthesizer.

You can check this for yourself if you can put a *good clean* (low noise) unmodulated signal into the front end at about 15 to 20 dBm. Tuning the receiver through either side of the passband will give you aural indication of just how clean the synthesizer in the receiver is. Any 'birdies' you hear indicate reciprocal mixing. How bad it is has to be quantitatively established.

Our recommended performance figures for HF transceivers are set out in the accompanying box as a reference with which to judge the Icom IC-735 test figures. As far as the transmitter is concerned, we believe the figures given for VHF equipment suffice and are attainable in practice at HF.

DESIRABLE PERFORMANCE SPECIFICATIONS

Receiver sensitivity

1. SSB, CW 0.5 μ V emf (-113 dBm) for 10 dB SINAD in 3 kHz bandwidth.
AM 2.2 μ V emf (-100 dBm) in 8 kHz bandwidth modulated 30%.
FM 0.8 μ V emf (-109 dBm) for 122 dB SINAD in 15 kHz bandwidth, peak deviation 9 kHz.
2. Third order Intermodulation (IMD) intercept (dBm) = 0 dBm.
3. Noise floor (minimum discernible signal) MDS = -140 dBm for 2.5 kHz bandwidth.
4. Blocking/dynamic range = 130 dB.
5. Reciprocal mixing = >90 dB at 10 kHz. Normalised for 1 Hz, a good figure is 140 dB/Hz.
6. Spurious responses less than equivalent MDS level.
7. IF rejection 100 dB minimum.
8. Image rejection 100 dB minimum.
9. Stability at least 2 ppm (60 Hz at 30 MHz) after 15 minute warm up and measured over 1 hour period.
10. Input impedance 50 ohm.

Transmitter

1. Spurious outputs: -70 dBc (All products)
2. 3rd order IMD 2 tone: -35 dBc
3. Carrier suppression: -60 dBc
4. Unwanted sideband: -60 dBc

We have introduced a new test figure that is not normally seen in the literature and this is input impedance to the receiver.

Although we (and the manufacturer) expect the input impedance to be 50 ohm, in practice this is rarely achieved because impedances in input circuitry will change with frequency. Variations can be engineered out but at some cost.

The effect of this is to produce a VSWR on the coax line, in exactly the same way as would occur if the transmitter was not matched to the line. Voltage and current levels are of course minute. The only effect that you would notice is a slight variation in sensitivity where VSWR was high.

The wise men have always pointed out that an antenna coupler is just as important when receiving as it is when transmitting and since this box is a general coverage receiver, a tuner/coupler would be of additional value.

We found that the best match was at 4 MHz where impedance was around 55 ohms and worst at 23 MHz where input impedance was 450 ohms.

See the test report for figures at other frequencies.

Test figures

Generally speaking the test figures indicate that we were dealing with a very good unit. In a little detail then:

1. Sensitivity. Both manufacturer's specification and our lab tests were reasonably in accord. For some reason we showed a better AM figure than Icom but all in all,

the figures for all modes were good.

2. MDS. We set a figure of -140 dBm for the noise floor of MDS. The test figure gave -133 dBm with the pre-amp on. From a practical sense, the figures are somewhat academic as atmospheric noise would limit the usable sensitivity to around -120 dBm (0.22 μ V) anyway. Nevertheless, it is a very good test figure.
3. "S" meter sensitivity. The figures are in reasonable accord with IARU specs but overall, the S meter is a little optimistic except at S6, where it was spot on.
- 4-6. Spurious response, IF rejection, Image rejection. Our figures on these three parameters show that Icom has a very good receiver. They are very close to our standard.
7. Input Impedance. Not a big deal as explained earlier, but at 23 MHz the input impedance is almost 450 ohms. At other frequencies you wouldn't notice the difference.
8. Reciprocal mixing/dynamic range. I have had the feeling during the writing of this review that maybe a lot more explanation and definition of terms should be given. Some technical feedback is warranted, and in a future issue a more detailed exposé of what we are measuring and how it affects your receiver's performance deserves attention.

The parameters are not fully understood by many people and without going to the lengths of a separate article, let me say that this receiver is capable of excellent performance. Some reciprocal mixing noise and birdies were apparent during the lab tests, but in actual on-air use, you would find them difficult to hear.

All other specifications speak for themselves and don't require comparisons.

Technically, both transmitter and receiver pass what I believe is a severe test and should be capable of excellent 'on air' performance.

A look at some of the circuit details should show 'why is it so'.

Block diagram

The schematic doesn't hold too many surprises: well proven and tried principles are still giving excellent performances and Icom manages to tie 124 transistors, 18 FETs, 42 ICs and 258 diodes together fairly well. Why manufacturers persist in advertising the component count is difficult to understand. I would have thought that it would be smarter to advertise the same performance with fewer components, but I guess the customers would feel they were not getting their money's worth!

The receiver section always gets attention — after all what you hear and how well you hear it is probably the deciding factor when buying a box, or mounting evidence when arguing with one's contemporaries! Icom has a good front end — no question, and correct responses are optimised with use of band pass filters — six cover from 2 to 30 MHz and low pass filters cover 0.1 to 1.6 MHz. Above 1.6 MHz, high pass filter

precedes the band pass filters to reduce the effects of cross modulation from broadcast stations.

The mixer (Icom calls it "Direct Feed Mixer") is an active FET mixer and gives the good IMD figures we have listed. This type of mixer also provides good isolation hence little local oscillator radiation. The up conversion to 70.4515 MHz is good for image rejection too.

Frequency generation is worthy of further study and for those with cryptic crossword mentality, following through the workings of four VCOs and how they are controlled by the processor should be an interesting exercise. Injection frequencies, naturally, are on the high side of the IF (70.5515 — 100.45125 MHz) and keep spurious responses of birdies from the PLL at a minimum.

Frequency readout is the now conventional 'the-processor-hopes-it's-the-right-frequency' type. The only readout in recent memory that was a frequency counter type, came from Kenwood. One effect we did not appreciate was a discrepancy in tuning. When tuning in an FM signal, the signal did not appear to be tuned unless it was about 2.5 kHz off the signal generator frequency.

This reflected in distortion tests until we realised that the readout did not agree with what was on the signal generator. Fortunately this effect was only noticed on FM, and, when calibrated, direct readout dials have proved quite reliable and accurate.

Overall

In the limited time available for on air tests, the impression was good and the audio well received by others.

The passband tuning control and notch filter were very good at improving selectivity, and audio tone.

One annoying feature was a click that comes from the speaker when the tuning knob is rotated and band edges are tuned over — all shaft encoders do it to a certain extent, though.

The manual leaves a bit to be desired. (Well Icom has never been noted for supplying a surfeit of technical information.) Calibration information is omitted and presumably a separate service manual will make its appearance at some time. It would be nice for Icom to share its knowledge of how the equipment operates. After all, amateur radio is supposed to be a technical hobby where the enthusiasts presume to know a little about the technology. The Icom manual for operators is fine, but does little, if anything to contribute to the amateur's knowledge of this technology — both analogue and digital.

The Icom IC-735 is very good technically. Its potential will enable it to keep up with difficult band conditions as long as there are signals. If cost effectiveness is a consideration, then \$1584 for the box and PS55 ac power supply may be considered to be a good investment if performance is the object.

The Icom IC-735 by itself is to be recommended and with RTTY via the RS232/personal computer a comprehensive station exists.

Pity about that tuning though!

Peter Williams is director of Associated Calibration Laboratories in Melbourne.

Lab Report
ICOM IC-735 HF TRANSCEIVER

1. RECEIVER: SENSITIVITY. MICROVOLTS P.D. or dBm.

0.1 - 1.6 MHz @ 1 MHz

	PREAMP ON		PREAMP OFF	
	LAB	ICOM	LAB	ICOM
SSB/ CW	0.8uV (-109dBm)	not used	0.8uV (-109dBm)	1.0uV
AM	1.9uV (-101uV)	not used	1.9uV (-101uV)	6uV
FM	4.4uV (-94dBm)	not used	4.4uV (-94dBm)	No figure

1.6 - 30MHz @ 15 MHz.

	PREAMP ON		PREAMP OFF	
	LAB	ICOM	LAB	ICOM
SSB/ CW	0.2uV (-121dBm)	0.15uV	0.7uV (-110dBm)	not used
AM	0.3uV (-117dBm)	1.0uV	0.7uV (-110dBm)	not used
FM	0.6uV (-111dBm)	0.5uV	1.4uV (-104dBm)	not used

SSB/CW FIGURES FOR 10dB S/N
AM FIGURE FOR 10dB S/N with narrow filter.
FM FIGURE FOR 12dB SINAD.

2. MINIMUM DISCERNABLE SIGNAL (MDS).

No manufacturer spec.
Test frequency 15.010 MHz.
Preamp off: -126 dBm.
Preamp on: -133 dBm.

3. "S" METRE SENSITIVITY.

	uV P.D.	=	Lab.Figure	IARU Spec.
S1	2.08	=	-100.6dBm	-121 dBm
S2	2.44	=	-99.2	-116
S3	2.94	=	-97.6	-102
S4	3.7	=	-95.6	-96
S5	4.66	=	-93.6	-91
S6	6.28	=	-91.0	-85
S7	8.67	=	-88.2	-85
S8	12.83	=	-84.8	-79
S9	21.8	=	-80.2	-72
+10	54.7	=	-72.2	-62
+20	206	=	-60.7	-52
+40	1157	=	-45.7	-32
+60	1456	=	-23.7	-12

4. SPURIOUS RESPONSES.

No manufacturer spec.
Should be less than equivalent MDS level of -126dBm (preamp off).

Frequency	14.8041 MHz	equivalent signal level	= -123 dBm
"	14.4705 MHz	"	" = -112 dBm
"	11.510 MHz	"	" = -112 dBm
"	9.0100 MHz	"	" = -95 dBm

NOTE: Several other spurious responses were noted at the -120 to -123 dBm level but were not considered important.

5. IF REJECTION:

Manufacturers Spec. more than 80 dB.
Lab. figure more than 98 dB.

6. IMAGE REJECTION.

Manufacturers Spec. more than 80 dB.
Lab. figure more than 100 dB.

7. INPUT IMPEDANCE. Nominal 50 ohm resistive.

Freq.	2. MHz	VSWR. (approx.)	1.22
"	2.2 "	"	1.22
"	3.8 "	"	1.2
"	6.4 "	"	1.1

8.0 "	"	1.22
13.4 "	"	1.5
20.0 "	"	1.5
23.0 "	"	8.9
25.9 "	"	1.3

8. RECIPROCAL MIXING.

Normalised to 1Hz is 120.6 dB/Hz.

9. BLOCKING DYNAMIC RANGE.

Manufacturers Specification 105 dB.
Lab. figure 104.2 dB DR Blocking.

10. THIRD ORDER INTERMODULATION DISTORTION: DYNAMIC RANGE.

No manufacturers Specification. 105 dB given in manual description but no mention in specifications.

Preamp on: Average 3rd. Intercept point + 13 dBm
Dynamic Range 110 dB.
Preamp off: Average 3rd. Intercept point + 28 dBm
Dynamic Range 109 dB.

Test done at mid band i.e. 15.1 MHz.

11. IN-BAND MODULATION DISTORTION.

Preamp on: Dynamic Range 72 dB.
Preamp off: Dynamic Range 71 dB.

12. RECEIVER FREQUENCY RESPONSE.

AM -3 dB point 2200 Hz and 100 Hz tone control mid position
Distortion (Total). FM/SSB 2.5% minimum, with FM tuned to
frequency 2.5 kHz low. AM 1.5% tuned 600 Hz high. (see
discussion in text.)

TRANSMITTER TESTS.

1. CARRIER SUPPRESSION:

Manufacturers Spec. 40 dB below peak power.
Lab. test. 60 dB below peak power.

2. INTERMODULATION:

No Manufacturers spec.
Third order products. 30 dB below full power.

3. UNWANTED SIDEBAND:

Manufacturers spec. Better than 50 dBc with 1 kHz input.
Lab Test 65 dB below peak power.

4. SPURIOUS:

Manufacturers spec. Better than 50 dB below peak power.
Lab Test 48 dB below peak power.

5. HARMONICS:

Lab. Test, harmonics 36 dB below carrier.

6. TRANSMITTER FREQ. RESPONSE:

At -3 dB points, 400 Hz and 2000 Hz.
Mic/tone control in mid position.

7. FREQUENCY STABILITY.

Manufacturers spec. 1. Less than +/- 200 Hz from 1 minute after
switch on to 60 minutes.
2. Less than +/- 30 Hz after 1 hour at 25°C.
3. Less than +/- 500 Hz in range 0 - +50°C.
Lab. Test, @ 25°C. Freq. 10 MHz. Mode AM.
1. +74 Hz in first hour.
2. +0.4 Hz in next 30 mins.
3. No test performed.

8. POWER OUTPUT:

Manufacturers spec. SSB 200 Watts PEP input
AM 40 Watts output
CW 200 Watts input
FM 200 Watts input.
Lab. Test, - ALC meter at scale.

POWER OUTPUT

Freq. MHz	FM	AM	SSB	CW
1.85	84.9	17	75	81
3.85	91.0	27	83	89
7.35	94.	31	86	92
10.35	95.	25	86	93
14.35	96	21	86	95
18.35	96	24	89	95
21.35	98	35	92	97
24.85	100	42	94	100
28.85	101	22	94	100
29.85	102	18	92	99

TOURING AUSSAT

Jon Fairall

Amid secrecy and security befitting the Hughes name, ETI visited the factory where Aussat was built just a few weeks before the satellite was launched.

I HAVE DONE QUITE a bit of reporting on Aussat and the systems, economics and politics associated with it over the last couple of years. So it was quite an experience to actually stand in front of an Aussat satellite, discovering what it's all about.

To see where they made Aussat you fly into Los Angeles airport, through the smog and inversion layers, and then catch a taxi to the Hughes aircraft spaceflight facility in nearby El Segundo. If you are luckier than I was your taxi driver might speak English and then you won't do a tour of the whole of lower California on the way.

Part of the confusion was caused by the fact that Hughes is located in a dozen different plants in the Los Angeles area. Hughes has grown enormously fat in California, fed by military grants of unimaginable size. It's not the only company here either. This is R&D alley. All the big companies are here,

and they spawn a thousand little versions, subcontractors and sub-subcontractors on down the line. It's a business that employs thousands, costs millions.

Hughes

Richard Dore, one of the public relations officers at Hughes, was assigned to show your scribe around. His job is to sell Hughes to the general public, which doesn't seem too difficult a job most of the time. In his office I found glossy brochures for the patriotically inclined American, detailing the latest technology for annoying the Russians. The front cover features a ferocious looking eagle and the announcement that Hughes is "strong, ready and resolute". For the scientifically inclined there is another one with complicated looking diagrams of satellites and gyroscopes. There's even a publication all about Aussat for the Aussies. (In LA they love the accent. It's cute.)

The slight schizophrenia evident in the brochures is reflected in the way the company operates. There is a mania for security which reflects Hughes' role in the war machine. ID cards and security guards are the order of the day. Here you KNOW you are in the middle of the war machine. On the other hand there is an engaging enthusiasm for doing science that comes across in the way people show you their work. Maybe it's just the toys for the boys syndrome. Equal opportunity notwithstanding, there are no women on the shop floor at Hughes.

Away from the airconditioning in the PR man's office, Hughes Spacecraft looks like any other factory. If you expect gloss on the floor you'll be disappointed. The spacecraft are assembled in a long narrow room, known colloquially as the 'Hi-Bay'. There are about half a dozen of them, surrounded by scaffolding of round blue tubes about twenty feet high and ten feet across. These are the circular solar panels that almost form the trade mark of Hughes satellites. They also serve the function of making the satellites seem much bigger than they are.

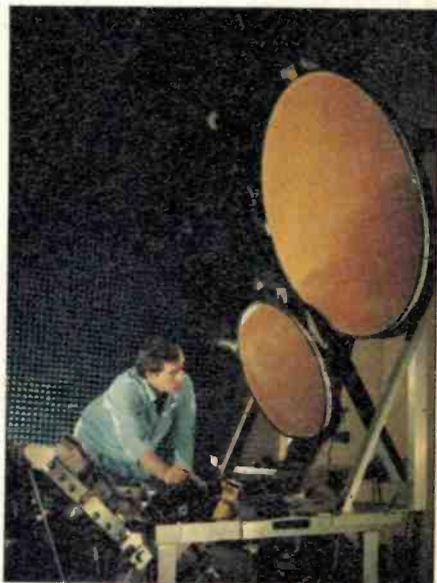

The alignment of the Aussat antennas is checked in an antenna farm at Hughes' facilities in California.

When you see one without its panels it's much less imposing. In fact you wonder why it cost \$40m and where 2500 man years of development went.

The spaceflight facility does differ in one respect from an ordinary factory: inside it is exceptionally clean, and it's strictly 'hands off the merchandise'. In fact they don't even like you pointing at things, as I discovered when I tried to stick a finger into the innards of a new Intelsat VI.

Satellites are actually very delicate. Since weight is an enemy to be fought at every turn nothing is over engineered. Technicians building them must use scaffolding to get at the bits because they can't climb on the satellite itself. When aloft all their tools are tethered by a wrist strap so they can't fall and do damage below. Even nuts and bolts are specially secured.

At one end of the assembly hall there is a maze of testing bays. Here they can do things like test the antenna farm (by transmitting and receiving from one end of the room to the other), and put it through

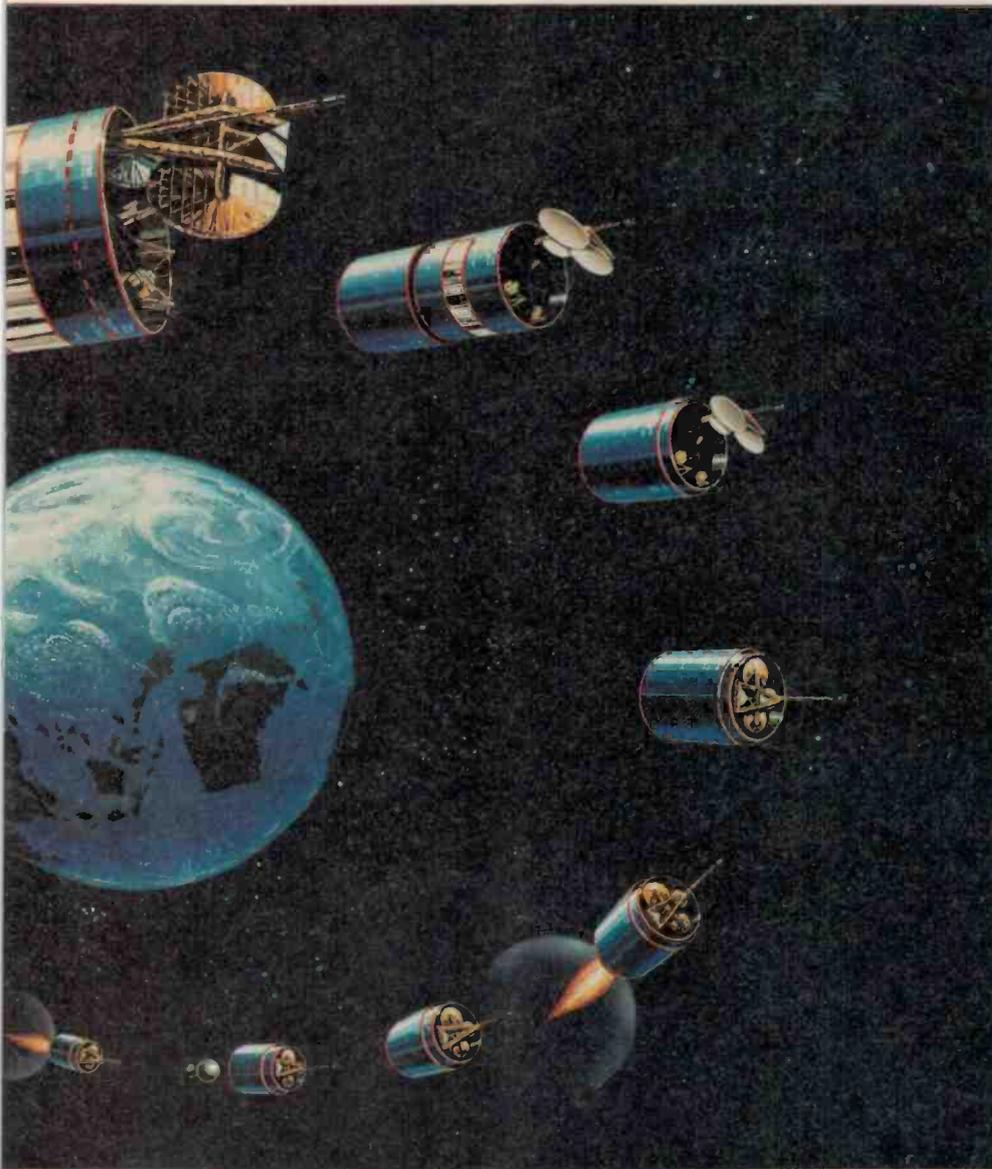

vibration tests. The vibration tester is a large plate of metal that can be vibrated in a regular (sine wave) mode at up to 100 Hz. There is also an irregular random movement mode that has been found from experience to closely match the stresses imposed by lift off in the space shuttle.

On one side is the space simulator, where all the important aspects of space flight can be simulated, except zero G of course. It's a big metal tank in which they can achieve a vacuum of 10^{-13} torr, and comes equipped with a heater to simulate the sun. Various other kinds of radiation equipment ensure that it can withstand the intense radiation that exists in space.

There are a few tests Hughes is not equipped to perform on its satellites, and for these the entire system is shipped out to another contractor. One of these is a noise test. The satellite must endure the noise of a launch in the cargo bay of the shuttle, where sound pressure levels in excess of 130 dB can be recorded. That's enough to kill a man.

Aussat 2

When I was there, the main subassemblies of Aussat 2 were being tested prior to final assembly. It's almost disappointingly simple. There are two sections, the spun and the despun assemblies. The despun section is the topmost part of the satellite. Deployed in space, this section carries the antennae, all the waveguides and the major repeater and amplifier elements. It remains stationary in space with its antennae looking at Australia.

Below it is the spun section. This section spins at about two revolutions per second and provides the gyroscopic action which stabilises the satellite. It contains the electronics, the fuel cells, batteries and gas motors. The solar panels are anchored to this section so that from the outside it looks as if the whole satellite is spinning. The Apogee Kick Motor (AKM) used to boost the unit into its final orbit is also secured to this section.

The foundation of both units is a thin aluminium shelf made of weight saving honey-

comb construction. This is the most dominant feature of the design so the two halves are often referred to as the spun and despun shelves. They are linked together by a special unit called a BAPTA (Bearing and Power Transfer Assembly). The BAPTA is a proprietary Hughes design shrouded in secrecy, and questions from enquiring journalists were not welcome; nevertheless, it is obviously some kind of extremely low friction mechanism for keeping the two halves of the satellite together while transferring power and data between the sections.

Top shelf

The most complex looking feature on the despun shelf is the wave guide array. This is an enormously complex example of the plumber's art, interconnecting the interchangeable horns and travelling wave tube amplifiers (TWTAs). All Aussat satellites have a specially designed top shelf and antenna farm to provide the particular services Australia requires. The three antennae have to provide three receive beams and seven transmit beams. This is done by using a dual polarised antennae, effectively making each antenna a double aerial, and also by having a variety of horns clustered around the focal point. By moving the position of these horns it's possible to change the directionality of the reflector, so providing spot beams to give small area coverage.

In all there will be fifteen channels through Aussat. Four will use high power 30 watt transponders, the remainder will use 12 watts. Two 12 watt and two 30 watt transponders are set aside for redundancy. Conceptually, the system couldn't be simpler; a ground signal is picked up by a receive antenna, amplified and retransmitted. The actual way it's done is anything but simple. The signal is exceptionally faint when it's received and it must be boosted to very high power. If it is to be of any value on the ground it must all be done with exceptionally low noise figures.

The core of each channel is a TWTA designed by Hughes and assembled in a special facility associated with the Hi-Bay. It is a device in which a microwave tube is made to interact with an rf field in such a way that energy is transferred from the electron beam to the rf wave. On Aussat these are placed around the rim of the despun shelf together with their associated power supplies. The power supply takes the standard spacecraft voltage and elevates it to about 1000 volts.

Special provision has to be made for heat-sinking these devices because they work so hot. In fact, heatsinking is one of the most crucial elements in satellite design. Since there is no atmosphere to conduct heat away, it must all be done by radiation. On Aussat the TWTAs are sited immediately behind the metal band visible on the outside of the satellite. This radiates the heat into space.

To improve the flexibility of the system and take care of future troubles which might

COMMUNICATIONS TODAY

A technician (right) checks the Bearing and Power Transfer Assembly (BAPTA) on the Aussat K1 spacecraft. The BAPTA is the link between the satellite's lower spun section shown here and the despun electronics shelf and antenna. Another technician adjusts one of the satellite's eight battery packs.

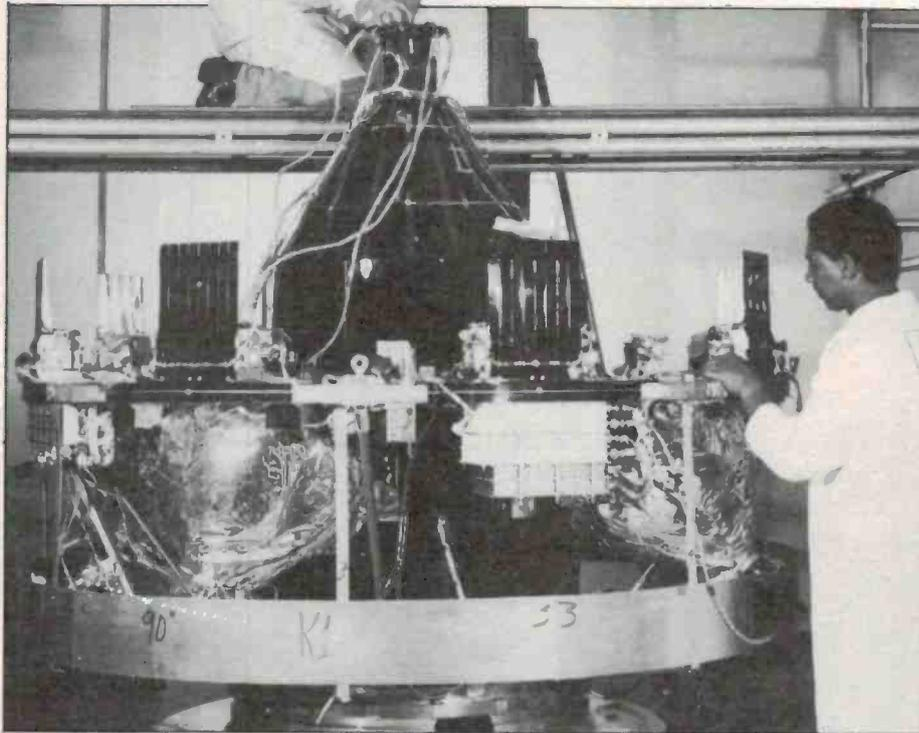

develop in the system, there is a switch matrix on board that will allow ground controllers to interconnect the different elements of the transmission path in a variety of combinations.

Bottom shelf

The spun section of the spacecraft contains the batteries and motors, as well as the fuel supply. Batteries are used to augment the solar cells of the spacecraft. Periodically its orbit will take it into the Earth's shadow, and the batteries have to be designed such that all spacecraft systems continue to function despite loss of solar power. They use nickel hydrogen technology to design the batteries. It's more efficient than ordinary NiCad, but considerably more expensive. Aussat has about 1000 watts available, which is reticulated in a 28 V supply.

Fuel supply for the rocket motors is held in four tanks made from titanium. Under normal atmospheric conditions they look as if they are made from tin foil, all thin and crinkly. In space however, they balloon outwards under gas pressure, and it's this pressure that provides the only means of getting the fuel to the four attitude rockets.

Two attitude rockets are located on the bottom of the spacecraft pointing along the spin axis. The other two are at the top and point at right angles to it. This combination allows ground operators to make rocket thrusts in any direction in spite of the spin of the spacecraft. Thrust of the rockets can be controlled very precisely, minimum burst being 1 ms, although apparently they are usually fired in 170 ms bursts.

... and beyond

In terms of spacecraft engineering, Aussat is already obsolete. The first HS376 was launched in 1977 for Satellite Business Systems. Western Union in the US now owns four (called Westar). Others have included three Palapa Bs for Indonesia, five Canadian Anik and two Brazilsats. Aussat will be the last in the line. That's not to say that Australia is not getting a good deal. We are getting a tried technology that will do what it is supposed to at a price we can pay.

But the next generation is just around the corner. The HS393 will have double the power and capacity of Aussat style satellites. It will look much the same but be some 30 per cent larger. Only slightly further down the track will be the HS394. This will have a 110 foot long solar array hanging off the despun section of a spinning satellite. The array will deliver 5000 watts of power, versus the 1000 watts of Aussat. ●

Aussat spacecraft configuration.

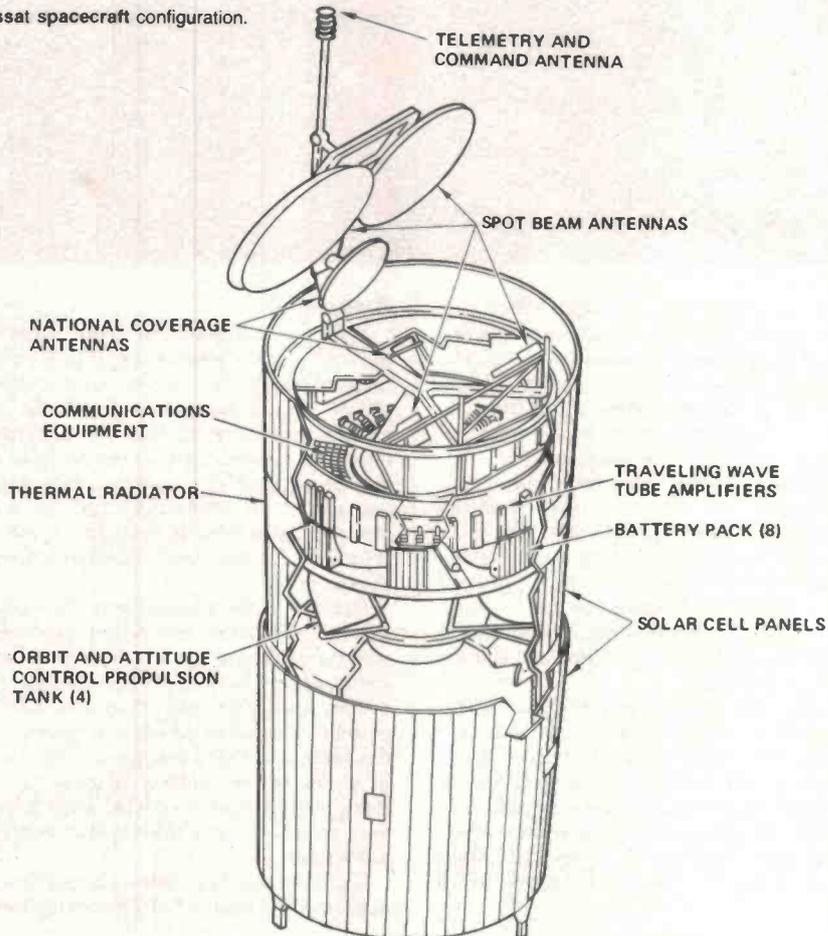

NEW! EASY NOTE PHONE MAIL ORDER PHONE NUMBER



RITRON 1
Our most popular model in a sleek cabinet to minimise R.F.I. interference.
Green. Cat. X14500 \$199
Amber. Cat. X14500 \$209



RITRON 2
Stylish swivel base monitor, available in amber or green 1-9
Green Cat. X14500 \$215
Amber Cat. X14500 \$219



PHOENIX 5
Suits Apple, Commodore, even your VCR!
●Pal and R.G.B.
●Normal Resolution
●13" CRT Dot Pitch 0.65mm
●Horiz. Resol. 320 TV lines
●Vert. Resol. 560 TV lines
●Display Characters 1,000 Ch.(40x25)
●16 Colours (Pal)
●Green text display
Cat. X14522 \$499



PHOENIX 4
●R.G.B. TTL
●High Resolution
●13" CRT Dot Pitch 0.31mm
●Horiz. Resolution 720 dots
●Vert. Resolution 240 T.V. Lines
●Display Characters 2000 Ch. (80 x 25)
●8 Display colours and intensity
●Green text display
Cat. X14520 \$849

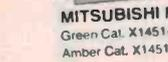

MITSUBISHI MONITORS
Green Cat. X14514 \$199
Amber Cat. X14516 \$209



SWIVEL BASE
Makes life easy!
Cat. D11100 \$29.50



ADD ON HARD DISK DRIVE FOR IBM
Includes disk controller card. Available and installed free only at our city store.
Cat. X20010 \$1,395
10 M Byte \$1,550
20 M Byte



APPLE JOYSTICKS
Ideal for games or word processing. Fits most 6502 "compatible" computers.
Cat. C14200 \$29.95



NEW 180 CPS PRINTER!
KAITEC KAI 180 EX
Standard 80 column Dot Matrix Printer. High quality printing by NLQ mode. 2K Buffer. High-speed, low-energy consumption. 9 wire dot head gears. Printing speed 180 C.P.S.
Logic seeking printing or incremental printing with high response, stepping motor. Use of fan-fold, roll or cut-sheet paper is possible with adjustable sprocket pin feed and friction feed. Both fixed and proportional character pitches are available. Emphasized and double print modes are possible. 9 graphic modes are available. 8 language international character font internalized.
SPECIFICATIONS:
Printing Type: Impact Dot Matrix
Maximum Printing Range: 203mm
Print Types: ASCII 96 Others 7 language
Character Format: Character Mode Standard 9 x 9 dots
NLQ 18 x 20 dots Graphic Mode
Printer Modes: (a) Fixed pitch mode (b) Proportional pitch mode
Character Size: 2.42(H)x 1.99(W)
Printing Speed: 180 Character per sec. (picas)
Paper Feed Method: (a) Adjustable sprocket pin feed paper width 4-10 inch (pull through) (b) Friction feed paper width 4-8.5 inch
Paper Feed Pitch: (a) Standard pitch 1/6 inch (b) Min. pitch 1/2 16 inch
Ink Ribbon: Special ribbon cassettes
Power Requirements: 240V + 10% 50 Hz
External Dimensions: 408(W) x 314(D) x 96(H)mm
Weight: Approximately 7.2kg
Ambient Environment: (a) 5-C-40C (less than 80% RH)
(b) Horizontal operating surface
Reliability: (a) MTBF 3x10⁶ lines (excluding print head and ink ribbon) (b) Print head life: 100x10⁶ characters (c) Ink Ribbon life: 2.5x10⁶ characters
Interface: Parallel interface 8-bit parallel (Conforms to Centronics)
Cat. C20020 \$690



MODEM PHONE
Check the features and the value for money of this stylish new modem phone...
●Speaker Phone with Built-In Amplifier for Detecting Busy Signal during communication.
●Auto/Manual Answer, Manual Originate, Auto Disconnect.
●Carrier Detect Indication, 20 Memos (each with 18 Digits Capacity) for Auto-dialing.
●BELL 103 CCITT V21 Compatible.
●300 BPS Full Duplex.
●Last Number Redial.
●Pushbutton Keyboard.
●Volume High or Low Control.
●FCC Approved Direct Connect.
●"In-use" Dialing Indicator.
Cat. X19105 \$199 (Not Telecom approved)



RITRON MULTI PURPOSE MODEM
Our New RITRON Multi Purpose Modem has arrived and has all the standards you require. Just check the Riton's features:
●CCITT V21 300 Baud Full duplex
●CCITT V23 1200/75
●Bell 103 300 Full duplex
●Bell 202 1200 Half duplex
●Auto answer, auto disconnect.
●Telecom Approval No. C8437/1134
Cat. X19105 \$379



BAUD RATE/BIT CONVERTER FOR RITRON MODEM
1200/75 baud
Cat. X19105 \$99



CICADA 300
●300 baud
●Provides full 12V bipolar output signal
●Direct connect modem
●Full duplex operation (Phone not included)
Cat. X19101 \$190



SUPPRESSION FILTER
●Suppresses over a wide frequency range 100Hz to 50MHz
●Incorporates voltage dependent transient suppression device
●Ideal for word processors, personal computers etc. Will also suppress interference on audio and video equipment
●Voltage drop on full load 1.5 volts
●Earth leakage at 250V 50Hz is 0.35mA
●DC resistance 50 milliohms - series inductance 3.5mH
●Current rating 6 amps at 250V-50Hz
Cat. X10094 \$39.95



MAINS MUFFLER
Sudden mains disturbances can seriously affect your computer equipment, and stored data. Why risk it, when you can have a Mains Muffler, particularly when the cost of one failure is likely to be greater than the purchase price!
Specifications:
Maximum total load:
1000w 4 AMP 250v 50Hz
First Stage- Single PI Section
Attenuation 150KHz - 400B
500 KHz - 65dB
10 KHz - 80dB
Second Stage- Dual T Section
Attenuation 150KHz - 200B
500 KHz - 60dB
10 KHz - 70dB
VDR Transient Suppression
Surge capacity 2000 AMP 8x20 uS
Cat. X10090 \$249



NEW! 64K PRINTER BUFFER KIT!
This kit, available exclusively from Rod Irving Electronics, is the ideal way to free up your computer when YOU want to use it! Do away with those annoying delays while your printer grinds away. This 64k buffer will hold 16 average pages of text! This kit is easy to build for the average hobbyist!
Cat. K96700 \$149



IC SPECIALS!
1-9 10+
4116 \$ 1.80 \$ 1.70 \$ 1.60
4164 \$ 2.50 \$ 2.25 \$ 1.95
2716 \$ 5.90 \$ 5.50 \$ 5.50
2732 \$ 6.25 \$ 5.95 \$ 5.50
2764 \$ 8.25 \$ 7.95 \$ 6.00
27128 \$12.50 \$11.50 \$7.50
6116 \$ 2.75 \$ 2.50 \$ 2.25
41256 \$9.00 \$8.00 \$7.50
62648 \$19.50 \$17.50 \$14.00



PRINTER RIBBONS
CP80, BX80, DP80, BX100, MB100
1-9 10+
\$9.90 \$8.50 \$7.90



ENP 1091/FT 5002
●Near letter quality mode.
●120 C.P.S.
●Down loadable character set
●Graphics. Italic, emphasized etc.
Cat. C20030 \$499



BX RANGE OF PRINTERS!
BX 100 \$370
BX 130 \$440
BX 130W (15") \$595



"IBM TYPE" COMPUTER CASING
Give your kit computer a totally professional appearance with one of these "IBM type" casings, includes room for 2 1/4 inch disk drives and connection ports. Dimensions 49x39x14cm
Cat. X11090 \$119



QUALITY COMPUTER POWER SUPPLIES
IBM* (to suit) Cat. X11096 \$239
Apple* (to suit) Cat. X11095 \$139



KEYBOARD AND CASE
Cat. X11080 \$249



APPLE* COMPATIBLE CARDS
Printer Card Cat. X17029 \$95
Drive Card Cat. X17019 \$95
80 Column Card Cat. X17025 \$95
Speech Card Cat. X17031 \$85



IBM CARDS
Multifunction Card (384K RAM) \$429
Disk Controller Card \$149
Hard Disk Controller Card \$399
Hercules Graphics Card \$249
512K RAM Card (Inc RAM) \$399



ROD IRVING ELECTRONICS
425 High Street, NORTHCOTE, 3070 VICTORIA, AUSTRALIA
Phone (03) 489 8866
48 A'Beckett St. MELBOURNE, 3000 VICTORIA, AUSTRALIA
Ph. (03) 663 6151
Mail Order and correspondence: P.O. Box 620, CLAYTON 3168
TELEX: AA 151938



MAIL ORDER HOTLINE
(03) 543 7877
(2 lines)

POSTAGE RATES
\$1-\$9.99 \$2.00
\$10-\$24.99 \$3.00
\$25-\$49.99 \$4.00
\$50-\$99.99 \$5.00
\$100-\$199 \$7.50
\$200-\$499 \$10.00
\$500 plus \$12.50
This is for basic postage only. Comet Road freight, bulky and fragile items will be charged at different rates.

Certified Post for orders over \$100 included "Tree"
Registered Post for orders over \$200 included "Tree"



Errors and Omissions Excepted.



IBM* COMPATIBLE COMPUTER
Incredible deals to suit everyone! All include colour graphics card, multi function card, disk controller card, 2 serial and 1 parallel ports. Your choice of 256K or 640K and the option of our special "package deals", which include a 120 C.P.S. printer and a monochrome monitor, all available at incredible prices including a 3 month warranty!

256K \$1,950
256K package deal \$2,400
640K \$2,100
640K package deal \$2,500
*IBM is a registered trademark.



COMPUTER CASSETTES
Quality 20 minute tapes
Cat. D11141
1-9 10+ 100+
\$1.50 \$1.40 \$1.20

SPECIAL!

1-9 10+ 100+
\$9.90 \$8.50 \$7.90

5 1/4" FLOPPY DISK SPECIALS!

XIDEX 1-9 10+
S/S/D/D \$31.00 \$29.00
Cat. C12401
D/S/D/D \$38.00 \$36.50
Cat. C12410
VERBATIM DATALIFE S/D/D/D \$27.95 \$26.95
Cat. C12501
D/D/D/D \$39.95 \$37.95
Cat. C12504
VERBATIM VALULIFE S/D/D/D \$24.95 \$22.95
Cat. C12421
D/D/D/D \$31.95 \$29.95
Cat. C12425

BX RANGE OF PRINTERS!

BX 100 \$370
BX 130 \$440
BX 130W (15") \$595

"IBM TYPE" COMPUTER CASING

Give your kit computer a totally professional appearance with one of these "IBM type" casings, includes room for 2 1/4 inch disk drives and connection ports. Dimensions 49x39x14cm
Cat. X11090 \$119

BankCard
VISA
MasterCard
Signature
Name
Address
PCode
ETI 1065
Expiry Date

Win this hobbyist's CRO Two to win!

It's easy. You could have one of these easy to use oscilloscopes on your work bench. This lightweight 6.5 MHz CRO will be great for building, testing and modifying your projects.

All you have to do is answer four simple questions. If you have any difficulty you can find clues in the Starting Electronics feature starting on page 92 in this issue. To enter use the coupon below.

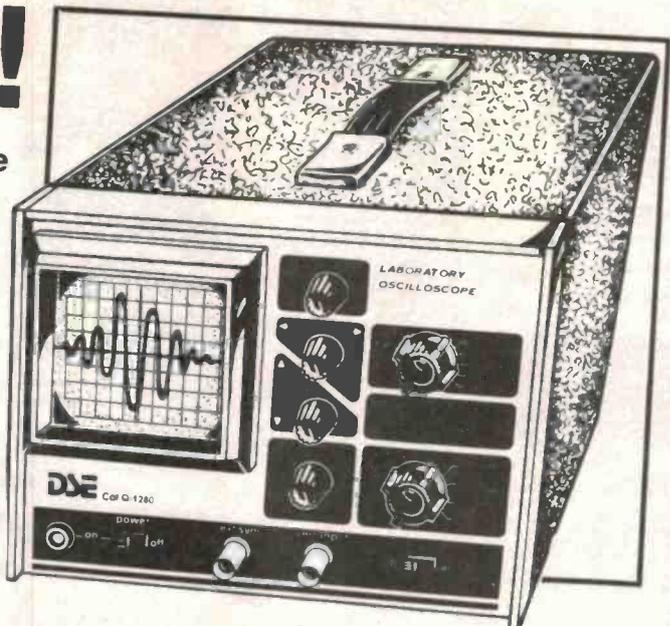

QUIZ QUESTIONS

1) Which of the following applications would you use single strand wire for?

- A) Audio
- B) Power
- C) Breadboarding

2) What is a typical value for capacitance per metre for shielded cable?

- A) 100 pF/m
- B) 200 pF/m
- C) 300 nF/m

3) How many pins does an RS-232 plug have?

- A) 25
- B) 36
- C) 50

4) What size phono connector is commonly used in telephone switch boards?

- A) 2.5 mm
- B) 3.5 mm
- C) 6.5 mm

The quiz answers are:

(circle the correct answer)

1) A B C

2) A B C

3) A B C

4) A B C

DICK SMITH
ELECTRONICS
PTY LTD

Send your entry to:

Win a CRO
Electronics Today
PO Box 227,
Waterloo,
NSW. 2017

Name

Address

Postcode

Telephone

(SA readers may enter on a separate piece of paper)

Offer closes December 1

AFFORDABLE HOBBYIST'S CRO

Dick Smith Electronics has on sale a very attractive oscilloscope at the price of \$299. Our labs, always complaining of tight budgets, were interested so we picked one up for review. The conclusion — for the price it's a solid hobbyist's measuring device.

Neale Hancock

EVER BEEN IN the situation where you are racking your brains as to how to remove those last bugs from a kit or project? I suppose the thought "if only I had a CRO" may have crossed your exasperated mind, but the constraints of bench space and budget have outweighed the benefits. Well, the Dick Smith Electronics oscilloscope (catalogue no Q-1280) may be the solution to your woes.

This lightweight and compact oscilloscope is ideal for observing waveforms which are typically encountered when constructing, debugging and modifying projects. For viewing waveforms with respect to time (ie sinewaves, squarewaves etc) there are four sweep ranges which can be selected on the timebase, relating to the range in which your particular circuit is operating. The 6.5 MHz bandwidth is achieved by increasing the sweep frequency via the VARI SWEEP control; this knob is also used to assist in triggering the time base to achieve a more stable waveform trace.

External triggering is achieved by using the EXT SYNC input in conjunction with the SYNC switch in the EXT position. This allows the use of an external triggering signal to synchronise the trace.

The SWEEP RANGE control (commonly known as the timebase) also has provision to display x-y traces. This capability in a single trace oscilloscope is extremely useful as it lets you display the amplitude of one voltage against another. To implement this feature the y signal is connected to the VERT INPUT and the x signal is connected to the EXT SYNC/HORIZ INPUT; the SWEEP RANGE is switched to EXTERNAL. The trace can be expanded horizontally and vertically via the SWEEP VARI and VERTICAL GAIN controls respectively.

In an environment where work space is



compromised by a plethora of tools, test equipment and components, space is rather valuable. Therefore light weight (3.8 kg) and compactness (200 mm [wide] x 160 mm [high] x 300 mm [deep] approx) are quite an advantage. In applications where the CRO is used away from the workbench (hi-fi servicing for example) this CRO's light weight and compactness are an advantage. The fast warm up time (20 seconds) lets you get on with the job at hand.

In the examination of waveforms it is desirable to have a calibrated grid to make rough measurements of time and amplitude from the screen. The grid is usually calibrated horizontally by marking "time per division" on the sweep range knob and "volts per division" on the vertical gain attenuator knob. However the DSE oscilloscope does not have these calibration markings; instead it shows the sweep range in Hz

and the vertical gain attenuation as a ratio. If you need to make measurements on the displayed waveform by the CRO itself, it will need to be calibrated.

Rough voltage calibration may be achieved by setting a reference level with the aid of a multimeter so that you can read voltages relative to that level. As the input amplifier and attenuator of the CRO are linear, this reference will still be valid for the different settings on the vertical gain attenuator.

For the hobbyist who is not willing to spend over \$300 on an oscilloscope, but is looking for a basic portable one for examining waveforms, the DSE oscilloscope should meet your requirements. However if you want accurate measurements of both voltage and time you should be prepared to look at something more comprehensive and, of course, more expensive. ●

KIT ETI1528 Intelligent Door Lock Kit \$125.00

Includes the 16 key membrane keyboard, high quality reed relays & DPDT relays, transformer, 1.2AH recharge battery & case.

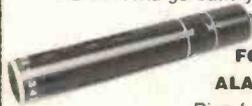

REMOTE CONTROL FOR THE CAR ALARM ETI 343

Ring for the PRICE



BOOKS

LATEST JAPANESE IC & TRANSISTOR DATA BOOK

ALL \$22.00 each

TRANSISTOR DATABOOK includes 2SA12 to 1401, 2SB12 to 1088, 2SC11 to 3557, 2SD11 to 2SD11 to 2SD1609 with details on pin diagram, made, type, Vcbo, Vcbo, Vcbo, hfe Icbo etc.

FET DATABOOK.....\$22.00 **OP-AMP DATABOOK (2)**..\$22.00

TTL IC DATABOOK.....\$22.00 **A-D/D-A DATABOOK**....\$22.00

C-MOS IC DATABOOK..\$22.00 **LINEAR IC MANUAL**....\$22.00

OP-AMP DATABOOK (1)..\$22.00 & others

IC COMPONENTS

COMPUTER IC SPECIAL

4164 64K x1 DRAM	Japanese prime spec.
QTY	PRICE (incl. SALES TAX)
1-24	\$2.50
25-99	\$2.30
> 100	\$1.90

6264LP-15 8K x 8 S RAM	\$13.50	EPROMs 2716	\$6.00
6116P-4 2K x 8 S RAM	\$ 7.90	2732	\$8.50
2114AP-2 1K x 4 S RAM	\$2.95	2764	\$9.50

6502ACPU	\$11.00	AY3-8910 sound eff.	\$11.50
6522 VIA	\$12.50	74LS series	4000 CMOS series
AY5-3600 keyb'd IC	\$11.50		

CABLES

SERIAL CABLE for your computer each conductor is colour coded with 7/0.16mm tinned copper cable with mylar shield & earth drain wire.

9 way	O.D. 5.8mm	\$1.50/meter	\$45.00/30m roll
25 way	O.D. 9.4mm	\$4.50/meter	\$108.00/30m roll

FLAT CABLE grey colour for IDC connector

16 way	\$1.80/M	\$ 88.00/61M roll	36 way	\$4.20/M	\$205.00/61M roll
26 way	\$3.00/M	\$150.00/61M roll	50 way	\$6.00/M	\$300.00/61M roll

RAINBOW CABLE multi colour

10 way	\$1.00/M	\$ 80.00/100M	16 way	\$1.60/M	\$128.00/100M
12 way	\$1.20/M	\$ 96.00/100M	24 way	\$2.40/M	\$192.00/100M

VIDEO CAMERA CABLE 2x shielded, 2x 75ohm, 6 other colour coded, grey PVC \$3.80/M \$290.00/100M

MICROPHONE CABLE Black PVC with cotton filler

SINGLE CORE SHIELDED	14/0.18mm	\$1.10/M	\$ 88.00/100M
TWIN CORE	2x 14/0.18mm	\$1.50/M	\$120.00/100M

SECURITY CABLE black brown & white 4 x 7/0.18mm
4 way 50c/M \$35.00/100M 6 way 75c/M \$52.00/100M

COMMUNICATION CABLE white PVC twisted pair 1/0.5mm
4 pairs 60c/M \$ 48.00/100M 10 pairs \$1.60/M \$128.00/100M
ring up for TV cable, 50ohm cable, audio cables figure 8 etc.

MOTOR FOR CASSETTE

JAPANESE DC MOTOR for cassette

4.5V DC motor

SMALL	22mm dia. 18mm height	\$5.00
LARGE	27mm dia. 18mm height	\$6.00



EDGE CONNECTORS

44 way **DUAL EDGE CONNECTOR** 0.1 spacing suits COMMODORE 64 & VIC 20 gold plated, PCB solder pin \$11.50 each



50 way **DUAL EDGE CONNECTOR** 0.1 spacing IDC type suits APPLE II type of cards gold plated \$13.90 each

Full range of **TOROIDAL TRANSFORMERS 15VA to 625VA**

SPARE PARTS for the IBMXT & APPLE IIe, power supply, keyboards, case, components etc.

PCB & KITS for EA & ETI magazine



HICOM UNITRONICS INT. P/L.

7 President Lane, Carlingbah, N.S.W. 2229

Mall Order Hotline

02 524 7878

Bankcard & Mastercard

Welcome

POST & PACK CHARGE

under \$ 25	\$3.00
\$25 to \$ 49.99	\$4.00
\$50 to \$ 99.99	\$5.50
over \$100.00	\$7.00

Add extra for heavy items.



NO TRACE

Now, when you need a multimeter as well as an oscilloscope, you can still count on BWD

These analog and digital instruments have everything you'd expect from BWD. Up to 1000V, 20A, 20MΩ and

20,000 ohms per volt sensitivity; and the BWD label guarantees accuracy and dependability.

HC 129

For literature and full information, contact



BWD Industries Ltd.

P.O. Box 325, Springvale, Victoria 3171.
5-7 Dunlop Rd., Mulgrave, Victoria.
Phone: National (03) 561 2888. International 613 561 2888.
Telex: 35115
VIC. (03) 561 2888 N.S.W. (02) 684 1800

NEW! 24V 5A SEND FOR DATA
MODULAR POWER SUPPLIES

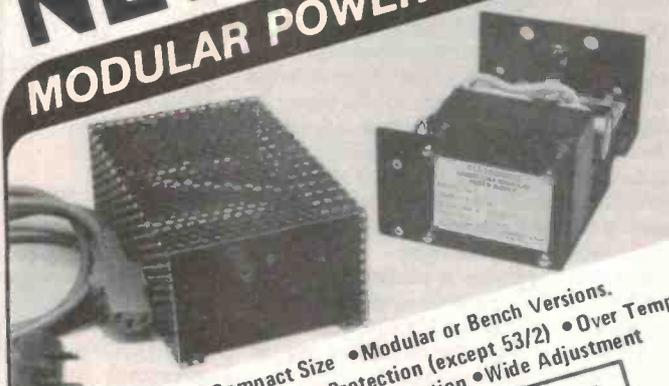

- Current Limiting • Compact Size • Modular or Bench Versions.
- Adjustable Crowbar Overvoltage Protection (except 53/2) • Over Temp Protection • 5mV Ripple • 0.5% Line Regulation • Wide Adjustment

VOLTAGE	CURRENT	MODEL	PRICE*
12 to 15V	1A DUAL	53/2	\$88.00
12 to 15V	3A	53/3	92.00
24V	2.5A	53/4	100.00
5V	3A	53/5	88.00

*For bench version add \$20.00. All prices + Sales Tax if applicable.

Statronics 53 Series

STATRONICS POWER SUPPLIES
103 Hunter St., Hornsby, NSW. 2077
Tel: (02) 476-5714, 477-5152
Vic: Klarion Ent. (03) 61-3801
S.A.: N.S. Dist. (08) 46-8531

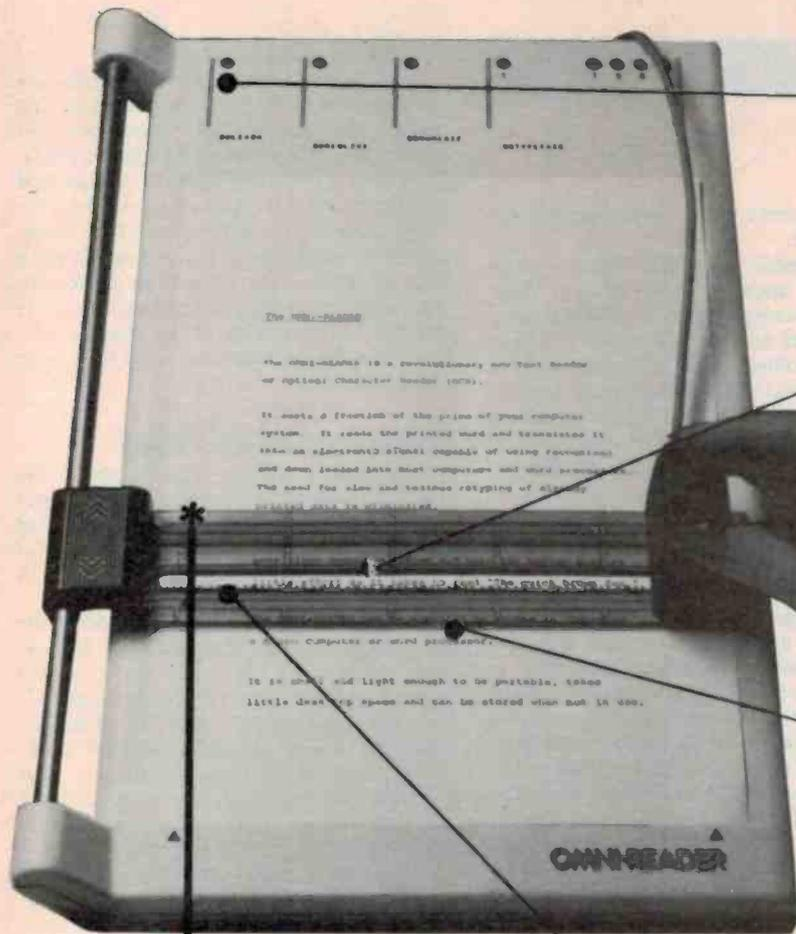

TYPEFACE QUALITY

OMNI-READER has the ability to read the recognized typefaces which have dark but fuzzy edges, often created by multiple photo copying.

TYPEFACE RECOGNITION:

The OMNI-READER comes pre-programmed to recognise the most common typefaces.

MANUAL OPERATION:

Alpha or numeric print is scanned line by line by moving the reading head along the text. Capable of scanning forward or backward — the reading head can be used to input all or just selections from the text.

GUIDE RULE:

A specially engineered guide rule makes text-alignment easy. Because of the unique clock-track, the reading head can be moved at varying speeds and still read the text.

OMNI-READER

reads the printed word and translates it into an electronic signal capable of being recognised and down-loaded into most computers or word processors.

Audio Engineers announce a revolution in taking words from page to your computer

Speed-reading & input of printed materials for:

- Word Processor Input
- Entering Electronic-Mail Text
- Storing/Editing documents for Electronic Filing.
- Transferring text between incompatible computers or WP's without re-typing.
- Input datatables or new data into Spreadsheet/dataBase programs.

OMNI-READER

attaches through a Serial RS232 interface as easily as a modem.

EXCLUSIVE TO

Audio Engineers

342 Kent St., Sydney 2000

Call (02) 29-6731 to arrange a demonstration or in W.A. call (09) 361-5954

DREGS

More electronic graffiti

BRITISH TELECOM HAS been running a service called Telecom Gold, which functions much like Telecom Australia's Telememo service (see our story on page 20). However the British version has run into trouble. Apparently the local likely lads have taken to entering salacious remarks on the message system. BT's lax attitude to this sort of thing has come under attack from members of the European Parliament. The Euro MP for West Yorkshire, one Barry Seal, has thundered that "British Telecom is running a sex-dating service that is like the smutty contact magazines sold in backstreet shops". This should all be food for thought for the more entrepreneurial of you.

The march of science

One of the biggest problems confronting NASA is that of making space a more 'livable' environment. Although the view is spectacular, weightlessness is Not Pleasant, by all accounts. According to a recent study, over 50% of astronauts spend the first three days in space being violently ill. It's not surprising therefore, that space doctors worry that astronauts aren't eating properly during their missions.

The picture that emerges from the study is that the typical astronaut spends his time in space vomiting, hungry and losing muscular and bone condition. Spending four hours a day on an exercise machine to keep

in shape doesn't make them feel less unhappy either.

Small wonder then, that over the years NASA has spent a great deal of time, money and energy trying to find out what kinds of food are best for people in space. The basic problem is that, without gravity to contain it, food will just float away. Liquids will not stay in cups, and dry foods do not crumble onto the floor, they float around the cabin in little, and potentially dangerous, crumbs.

The first American spacemen, like John Glenn, used toothpaste tubes. To have a meal one simply squirted a mixture of pastes into the mouth. Efficient, but given the way the guys were feeling at the time, not terribly attractive. The next step was plastic containers with 'rehydratables' in them. This is powder that could be injected with water from a water gun to turn into a gooey mess before being eaten. Small wonder the food on space flights started to become an issue for the astronauts when the long distance flights started. John Young, squeaky clean 'Right Stuff' type veteran was once embarrassed by flight controllers when he was caught eating a home-made corned beef sandwich he had smuggled on board.

Things started to look up on spacelab, which had a proper dining table, to which plates and cutlery were anchored by magnetism. The diners strapped themselves into chairs. The plates had eight compartments, three of which had heaters in them for

warming up refrigerated items.

The apogee of extra terrestrial culinary development is the space shuttle. This has a proper galley, in which space men and women can take it in turns to play mother. However, it's all so difficult to operate that it takes an hour to remove a meal from its store, inject water into the relevant items, and then arrange the heating. And when it's all over there is the PHS to be addressed. This is the personal hygiene station, and is familiar to many of us as the kitchen sink. And you always wondered what they were doing up there!

Useless software dept

Microlink Database publications in the UK has released the Naughty Words Editor (NWE). Its job is to sort out all the naughty words like **** and #### and !!!! in a bit of prose. The problem is that some words are nicer in some contexts than others.

The BBC, an organisation not known for its daring, reported that problems had occurred with "tits". "Tits" are nice, it seemed if preceded by "blue" or "greater crested", but not quite cricket when preceded by "big" or "melon shaped". Another problem is that NWE works on strings, so it identifies the naughty bits in all sorts of quite innocuous words. What are we to make of "entitled", for instance.

Apparently, NWE was written to stop a trend creeping into British life, ie, electronic graffiti. Apparently people are leaving less than edifying messages on terminals where they are seen by all sorts of impressionable people who then run amok, pillaging and destroying and generally having a good time.

This must #### stop.

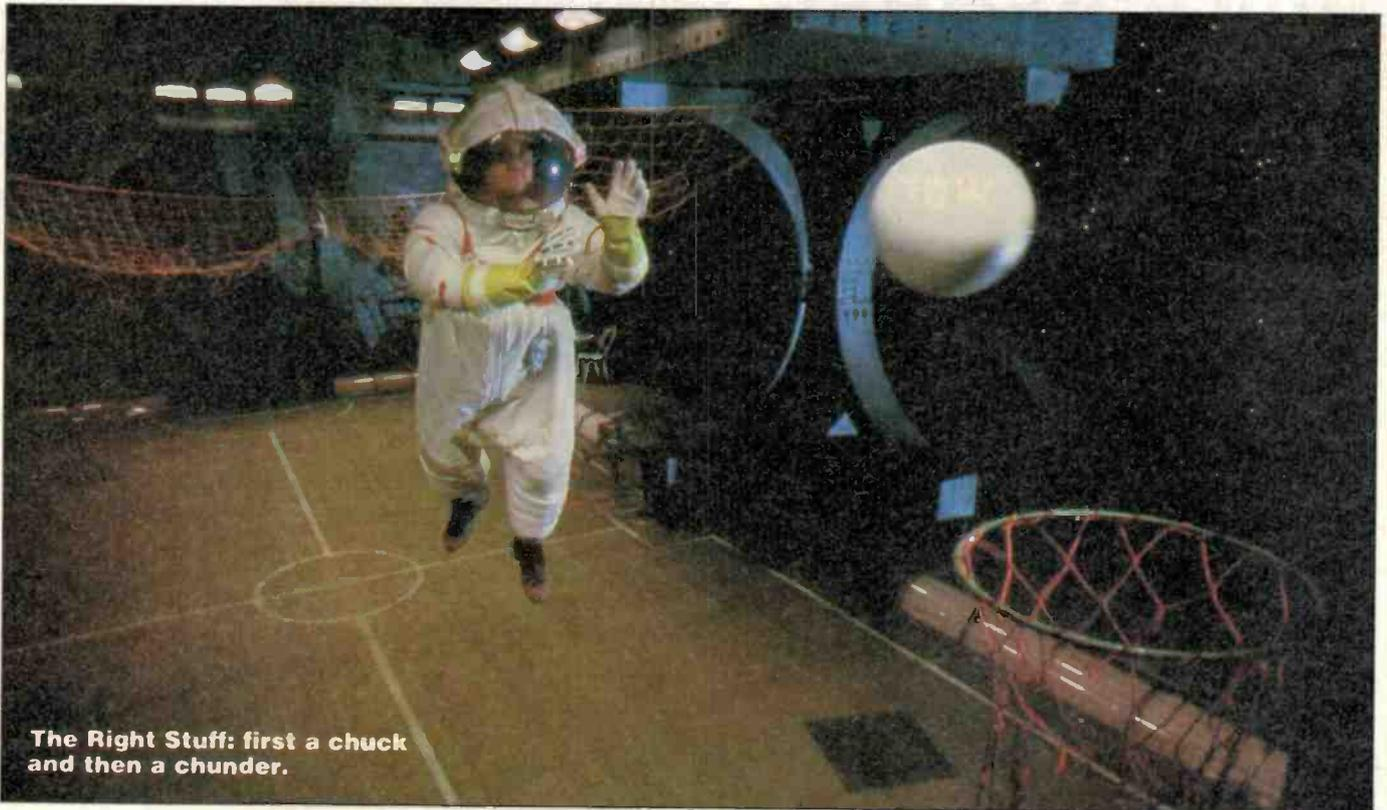

The Right Stuff: first a chuck and then a chunder.

Revox B225

For those who waited.
And those who wish they had.



STUDER REVOX

All Compact Disc players are *not* created equal. This much, at least, has emerged from all the hype and hoopla.

Some CD players are built better than others. Some have more sophisticated programming features. Some are easier to use. And, yes, some *do* sound significantly better than others.

The new B225, from Revox of Switzerland, excels on all counts. For those who have postponed their purchase, patience has been rewarded. For those who didn't wait, the B225 is the logical upgrading route.

First, the B225 is designed for unexcelled CD reproduction. By using oversampling (176.4 kHz) in conjunction with digital filtering, the B225 guarantees optimum sound resolution and true phase response.

For your convenience, the B225 offers programming of nearly every conceivable combination of start, stop, pause, and loop functions, in any sequence, and using mixed combinations of track numbers and times. Cueing time is always less than 3 seconds, and a single infrared remote transmitter (optional) operates the B225 as well as all other components in the Revox 200 audio system.

Finally, the B225 is a product of refined Swiss design and meticulous craftsmanship. Behind its face-plate of functional elegance, you'll find the B225 is an audio component built in quiet defiance of planned obsolescence.

Without question, the definitive CD player has now arrived. For those who waited (and those who didn't), now is the time to see an authorized Revox dealer.

SYNTEC INTERNATIONAL PTY. LTD.

53 Victoria Ave., Chatswood, N.S.W. 2067 (02) 406-4700
Vic: (03) 819-2288. Qld: (07) 371-3999. WA: (09) 328-1200

At Greenpar we've got thousands of connections worldwide, but only one in Australia.

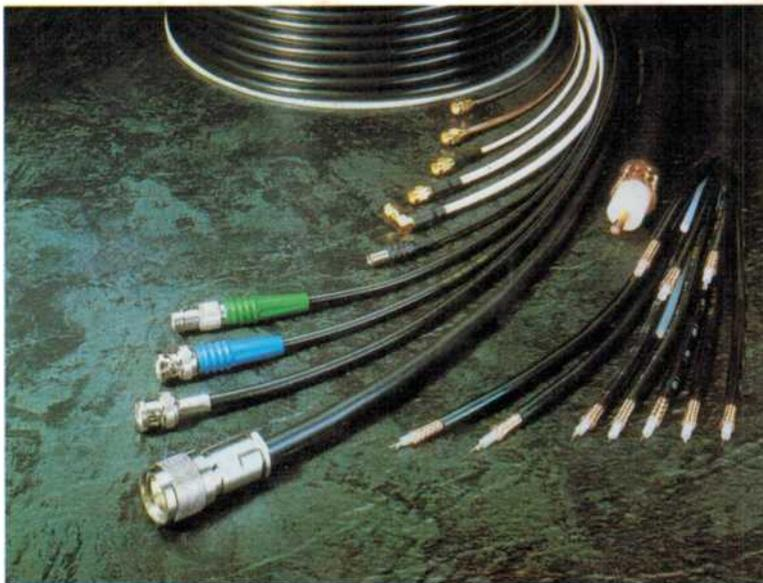

Greenpar Connectors manufacture an extremely wide range of coaxial connectors of many different styles and mating faces.

So wide in fact, that as one of the United Kingdom's leading lights in the industry, we have connections all over the world.

But only one here in Australia.

Acme Electronics.

They now stock Greenpar connectors for a wide range of configurations. And they're all readily available through an Australia wide network of outlets.

So whatever your connector needs make sure you make the right connection.

You can see the exclusive range of quality Greenpar connectors at IREECON '85 at the ACME ELECTRONICS STAND.



Available from:

ACME ELECTRONICS

A UNIT OF JAMES HARDIE INDUSTRIES LIMITED

VIC. 205 Middleborough Road, Box Hill. 3128. Telephone: 890 0900 N.S.W. 120 Beaconsfield Street, Auburn. 2144. Telephone: 648 2255
QLD. 62 Doggett Street, Fortitude Valley. 4006. Telephone: 854 1911 A.C.T. Electronic Components Pty Ltd. Telephone: 80 4654
S.A. Neil Muller Pty Ltd. Telephone: 272 8011 W.A. J G Thomas & Assoc. Telephone: 272 7122 TAS. W P Martin Pty Ltd.
Telephone: (Hobart) 34 2811 (Launceston) 315545 N.T. James Hardie Electrical. Telephone: 84 4904

JRA 3901HAR