

AUSTRALIA'S DYNAMIC ELECTRONICS MONTHLY!

MARCH 1985

\$2.50\* NZ \$3.25

# Electronics Today

INTERNATIONAL

**eti**

**EXCLUSIVE REVIEW:  
SMALLEST CD PLAYER**

**SPIES ON SHORTWAVE**

**SMART LOW-COST PRINTERS**

**CAPS REPLACE BATTERIES!**

**GREAT  
READER  
OFFERS**

See inside

**AUSTRALIA FIRST  
WITH SATELLITE TECHNIQUE**

**PROJECTS:**

**DIGITAL LUXMETER**

**LOW BATTERY INDICATOR**

**ENHANCER EXPANDS STEREO IMAGE**

March, April, May 1985  
**SPECIAL OFFER**

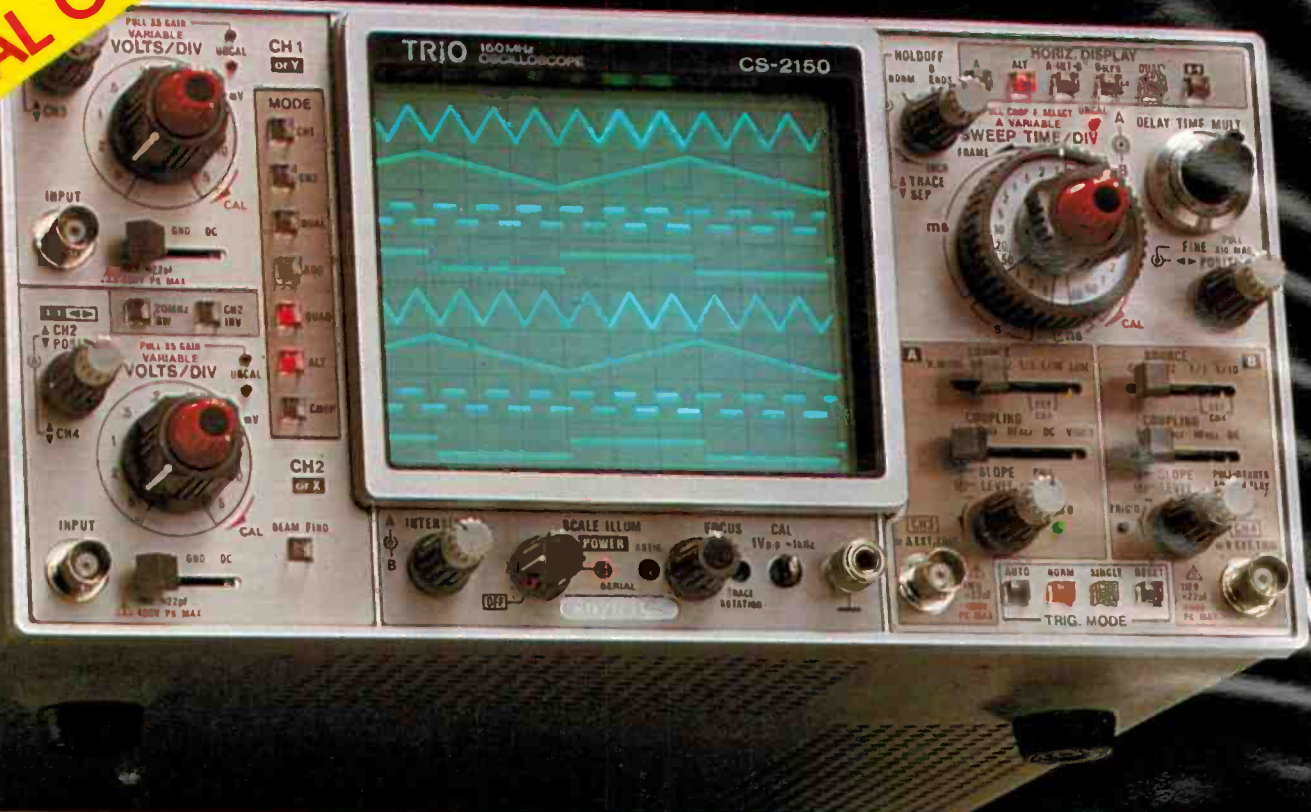

# Now you can afford Trio quality

Here's a chance for you to buy Trio at a price you'd expect to pay for an ordinary oscilloscope. And until April 1985 you'll get two free probes with every Trio CRO. That's a saving of \$158 with the CS-2150, and \$66 on the others (at tax free prices).

From 20MHz to 150MHz, there's a Trio CRO that will solve your problems. All are built to perform. Reliably. Accurately. And now they're priced affordably.

**CHOOSE FROM THESE VERSATILE MODELS:**

Model	Bandwidth	Channels	Trace	Sensitivity	Tax Free	Tax Paid
CS-1022	20 MHz	2	2	1mV/div	\$649	\$746
CS-1040	40 MHz	3	6	1mV/div	\$1175	\$1351
CS-1060	60 MHz	3	6	1mV/div	\$1495	\$1719
CS-2075	75 MHz	4	8	1mV/div	\$1995	\$2294
CS-2110	100 MHz	4	8	1mV/div	\$2495	\$2869
CS-2150	150 MHz	4	8	1mV/div	\$2695	\$3099
<b>PROBES</b>						
88100	100 MHz				<del>\$83</del>	<del>\$89</del>
99125	250 MHz				<del>\$79</del>	<del>\$94</del>

**Included FREE**

The 150MHz CS-2150 shown is our new top of the line model. It's been designed to meet the testing needs of the latest technology. Satellites. Compact discs. Manufacturing and design automation. Local area networks. These fields are making demands that few oscilloscopes can meet. The CS-2150 meets them. Take a look at these features.

- High vertical axis sensitivity of 1mV/div
- 2nS/div sweep for observation of high speed signals
- Delayed sweep for partial waveform expansion
- Four-channel/eight-trace.  ±2% accuracy
- Dual sweep to observe two widely different signals
- Bright, sharp 150mm rectangular CRT
- Guaranteed channel-to-channel time accuracy
- Optimum multi-clamping of video signals

Call either of our showrooms for more information or to arrange a demonstration of our full range of oscilloscopes. Our sales engineers really know Trio. And they'll make sure you get the scope you need. At the right price.

**SYDNEY:**  
 41 Herbert St, Artarmon, N.S.W.  
 P.O. Box 573, Artarmon, N.S.W. 2064  
 Phone (02) 439 3288. Telex AA25021

**MELBOURNE:**  
 53 Governor Rd., Mordialloc, Vic.  
 P.O. Box 122, Mordialloc, Vic. 3195  
 Phone (03) 580 7444. Telex AA33012

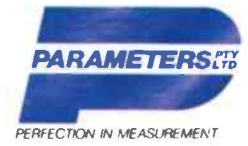

# Electronics Today

## FEATURES

<b>BMAC TV Transmission</b>	10
We'll pioneer its use with satellite TV	
<b>In-Circuit Emulation</b>	32
A look at this method to develop digital systems	
<b>Chatterbox Applications</b>	96
Ways to get BBCs and Commodores talking . . .	
<b>DX Sessions</b>	110
These regular programmes keep track of shortwave schedules	

## PROJECTS

<b>ETI-1405: Stereo Enhancer</b>	50
Boost separation from close spaced speakers!	
<b>ETI-182: Digital Luxmeter</b>	58
Measures absolute light levels from 1 to 20k lux	
<b>ETI-280: Low Battery Indicator</b>	66
An easy project that could save much embarrassment	
<b>ETI-342: Pulse-Shaped CDI System, Part 2</b>	72
All the benefits of CDI without the problems	

## REVIEWS

<b>Sony D50 CD Player</b>	20
Smallest and lowest price player is a real surprise!	
<b>Supercaps</b>	39
New types can be used as power sources	
<b>CPA-80 Printer</b>	93
This low-cost printer is very smart	

## OFFERS

Nashua floppy disks	86
Chatterbox offer	114
Benelec digital multimeter offer	120
ETI mail order books	70,90,91,92 & 106
Casio calculator, keyboard and computer offer	69

## DEPARTMENTS

News Digest	5	Ideas for Experimenters	84
Sight & Sound News	15	Idea of the Month	85
New Equipment	29	Shoparound	121
New Components	44	MiniMart	121
Computing News	87	Dregs	122
Communications News	117		
(Spies on shortwave)			

### EDITOR

David Kelly

### EDITORIAL STAFF

Mary Rennie  
Jon Fairall B.A.  
Geoff Nicholls B.Sc./B.E.  
Peter Inhat B.Sc./B.E.  
Robert Irwin B.E.

### ASSOCIATES

David Tilbrook VK2YMI  
Jonathan Scott  
B.Sc./B.E. (Hons) VK2YBN

### DRAUGHTING

David Curme

### ADVERTISING PRODUCTION

Danny Hooper

### ADVERTISING SALES

John Whalen (National)  
Cathy Darnell  
Kate Stuart

### ART DIRECTOR

Vicki Jones

### ART STAFF

Sharon Hill  
Brian Jones

### READER SERVICES

Elizabeth Barnett  
Felicity Skinner

### ACOUSTICAL CONSULTANTS

Louis Challis and Associates

### MANAGING EDITOR

Jamieson Rowe

### PUBLISHER

Michael Hannan

### HEAD OFFICE

140 Joynton Avenue, (PO Box 227)  
Waterloo, NSW 2017.  
Phone: (02) 663-9999 Sydney.  
Telex: 74488, FEDPUB.

### ADVERTISING OFFICES AND AGENTS:

**Victoria and Tasmania:** Virginia Salmon and Bruce Burrell. The Federal Publishing Company, 23rd Floor, 150 Lonsdale Street, Melbourne, Vic. 3000. Phone: (03) 662-1222 Melbourne. Telex: 34340, FEDPUB.

**South Australia and Northern Territory:** The Admedia Group, 24 Kensington Road, Rose Park, SA 5067. Phone: (08) 332-8144 Adelaide. Telex: 82182, ADMEDIA.

**Queensland:** Geoff Horne, C/- The Federal Publishing Company, 25 Balaclava Street, Woolloongabba, Qld. 4102. Phone: (07) 391-4041, (07) 391-8003.

**Western Australia:** Cliff R. Thomas, Adrep Advertising Representative, 62 Wickham Street, East Perth, WA 6000. Phone: (09) 325-6395 Perth.

**New Zealand:** Chris Horsley, 4A Symonds Court, Symonds Street, Auckland. Telex: NZ60753, TEXTURE. Phone: 39-6096. Auckland.

**Britain:** Peter Holloway, John Fairfax and Sons (Australia) Ltd, Associated Press House, 12 Norwich Street, London EC4A 1BH. Phone: (01) 353-9321 London. Telex: 262836, SMHLDN.

**Japan:** Genzo Uchida, Bancho Media Services, 5th Floor, Dai-ichi Nisawa Building, 3-1 Kanda Tacho 2-chome, Chiyoda-ku, Tokyo 101. Phone: (03) 252-2721 Tokyo. Telex: 25472, BMSINC.



**ELECTRONICS TODAY INTERNATIONAL** is published monthly by the Electronics Division of the Federal Publishing Company Pty Limited, 140 Joynton Avenue, Waterloo, NSW 2017. Typeset and printed by ESN-The Litho Centre, Sydney. Distributed by Gordon and Gotch Limited, Sydney. Cover price \$2.50 (maximum and recommended Australian retail price only; recommended New Zealand price, \$2.95). Registered by Australia Post, Publication No NBP0407. ISSN No 0013-5216.

COPYRIGHT © 1984, THE FEDERAL PUBLISHING COMPANY

# ICOM IC-R71A

## The Best Just Got Better



IC-GC4  
World Clock

ICOM introduces the IC-R71A 100kHz to 30MHz superior-grade general coverage receiver with innovative features including keyboard frequency entry and wireless remote control (optional).

This easy-to-use and versatile receiver is ideal for anyone wanting to listen in to worldwide communications. Demanding no previous shortwave receiver experience, the IC-R71A will accommodate an SWL (shortwave listener), Ham (amateur radio operator), maritime operator or commercial operator.

With 32 programmable memory channels, SSB/AM/RTTY/CW/FM (optional), dual VFO's, scanning, selectable AGC and noise blanker, the IC-R71A's versatility is unmatched by any other commercial grade unit in its price range.

**Superior Receiver Performance.** Utilizing ICOM's DFM (Direct Feed Mixer), the IC-R71A is virtually immune to interference from strong adjacent signals, and has a 100dB dynamic range.



IC-RC11  
Infrared  
Remote

Passband tuning, a deep IF notch filter, adjustable AGC (Automatic Gain Control) and noise blanker provide easy-to-adjust clear reception, even in the presence of strong interference or high noise levels. A preamplifier allows improved reception of weak signals.



**Keyboard Entry.** ICOM introduces a unique feature to shortwave receivers... direct keyboard entry for simplified operation. Precise frequencies can be selected by

pushing the digit keys in sequence of frequency. The frequency will be automatically entered without changing the main tuning control. Memory channels may be called up by pressing the VFO/M (memory) switch, then keying in the memory channel number from 1 to 32.

**VFO's/Memories.** A quartz-locked rock solid synthesized tuning system provides superb stability. Three tuning rates are provided: 10Hz / 50Hz / 1KHz.

**32 Tunable Memories.** Thirty-two tunable memories, more than any other general coverage receiver on the market, offer instant recall of your favorite frequency. Each memory stores frequency, VFO and operating mode, and is backed by an internal lithium memory backup battery to maintain the memories for up to five years.

**Options.** FM, synthesized voice frequency readout (activated by SPEECH button), RC11 wireless remote controller, CK1 DC adapter for 12 volt operation, MB12 mobile mounting bracket, two CW filters FL32 - 500Hz, and FL63 - 250Hz, and high-grade 455KHz crystal filter FL44A.

Discover a new deal with  
ICOM AUSTRALIA PTY. LTD.  
7 DUKE STREET WINDSOR 3181 VICTORIA, AUSTRALIA  
TEL: (03) 529 7582 TLX: AA 35521 ICOMAS

 **ICOM**  
The World System

**ADVERTISERS' INDEX**

Active Electronics .....	116
Altronics .....	99,100,101,102,103
Applied Technology .....	64,65
Aussat Pty Ltd .....	14
Bright Star Crystals .....	119
Daneva Australia .....	31
Delsound Pty Ltd .....	121
Dick Smith Electronics .....	80,81 82,83
Disco World .....	27
Electronic World .....	95
Ellistronics Pty Ltd .....	108,109
Emona Electronics .....	55
Emona Instruments .....	107
Energy Control .....	95
ETI Books .....	68,90,91,106
ETI Offers .....	69,86,113,114,120
Federal Publishing Co .....	36,46,92
Ferguson Transformers .....	38
GEC Automation & Control .....	68
Hewlett Packard .....	IBC
Hi-Tech Light & Sound .....	48,49
Icom Australia Pty Ltd .....	4
Jaycar Electronics .....	24,25
JED Microprocessors .....	88
Leisure Imports .....	115
Macro Dynamics .....	36
Mayer Krieg & Co .....	115
Parameters Pty Ltd .....	IFC
Plessey Components .....	92
Prepak Electronics .....	63
Promark Electronics .....	95,112
Rod Irving Electronics .....	43,47 57,70,71,79
Rose Music Pty Ltd .....	18,19
Scan Audio Pty Ltd .....	119
Scientific Devices .....	9
Scope .....	26
Siemens Ltd .....	42, OBC
Soanar Electronics .....	37,38
Sony Australia .....	17
Swann Electronics .....	55,95,121
Union Carbide .....	14
Warburton Frankl .....	115
Zap Electronics .....	28

This index is provided as an additional service. The publisher does not assume any liability for errors or omissions.

**COVER:** Picture supplied by Greg Northover of the Department of Communications.

**THE LAUNCH OF AUSTRALIA'S** first communications satellite in July will herald a brave new era for Australian broadcasting — right? Well some people with a lot of experience in the industry have their doubts.

The satellite could have meant that most Australians would get a new television service. They won't, because the Minister for Communications, contrary to the advice of his department, has decided to have all television signals on the satellite encoded. This is, in truth, to protect the big metropolitan networks from competition by their small country cousins.

The big networks are worried that city viewers will invest \$2000 or so in earth stations to pirate signals intended for country viewers. As these Remote Commercial Television Services (RCTS) will have less money to spend on their programmes than the big city stations, not many city viewers will bother.

So what's it all about? It seems like a waste of the money you pay in taxes.

Most, if not all, the television signals on the Australian satellites will be carried using a new transmission system called BMAC (see our feature on page 10). BMAC has many advantages. It provides a better picture as well as several sound channels, it can be used for encoding and for pay-TV.

The problem with BMAC is that it is the design of Scientific Atlanta in the US, which is partly owned by Plessey. Whomever you buy your earth station from, the decoder will have to come from Plessey. All your eggs in one basket!

The Department of Communications has insisted that all the pay-TV aspects of BMAC be kept in the Australian system. As the minister has said that RCTS will not be a pay-TV service, does this mean that country viewers of the ABC will have to pay for the service?

Before the dust completely settles on 1984 there is just one more thing about this last edict from the Department. Someone, somewhere in the Department will have a list of all those with BMAC earth stations. That person will be able to turn off the signal of any desired viewer and in its place put any desired message. Remember Big Brother loves you!



By the way we are making some changes in Electronics Today. In future those who write letters to the editor or technical inquiries may see their correspondence in print. If there's something you approve or disapprove of in Electronics Today or in electronics generally, then write!

**David Kelly**  
Editor

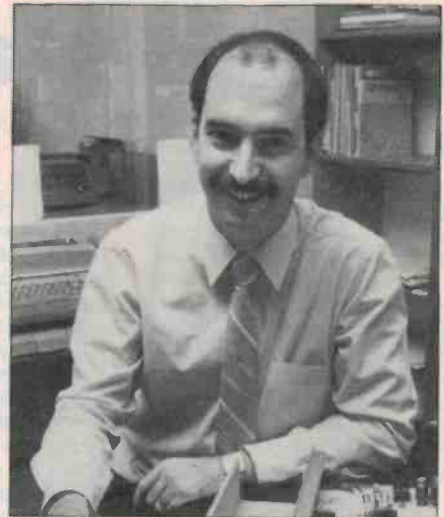

**SERVICES**

**TECHNICAL INQUIRIES:** Technical inquiries by mail must be accompanied by a stamped self-addressed envelope. There is no charge, but we reserve the right to publish the inquiry and the reply in Electronics Today or any of its associated publications. We can only answer queries relating to projects and articles as published. We cannot advise on modifications, other than errata or addenda. Difficult questions may take some time to answer.

**GENERAL INQUIRIES:** For all inquiries about back issues, subscriptions (\$24.00 for 12 months/12 issues), photocopies of articles, artwork or submitting articles, call (02) 663-9999 or write to: ETI Reader Services, 140 Joynton Avenue (PO Box 227), Waterloo, NSW 2017.

**CONTRIBUTIONS:** Submissions must be accompanied by a stamped, self-addressed envelope. The publisher accepts no responsibility for unsolicited material.

**COPYRIGHT:** The contents of Electronics Today International and associated publications is fully protected by the Commonwealth Copyright Act (1968). Copyright extends to all written material, photographs, drawings, circuit diagrams and printed-circuit boards. Although any form of reproduction is a breach of copyright, we are not concerned about individuals construct-

ing projects for their own private use, nor by bands (for example) constructing one or more items for use in connection with their performances. Commercial organisations should note that no project or part project described in Electronics Today International or associated publications may be offered for sale, or sold in substantially or fully assembled form, unless a licence has been specifically obtained so to do from the publisher, The Federal Publishing Company, or from the copyright holders.

**LIABILITY:** Comments and test results on equipment reviewed refer to the particular item submitted for review and may not necessarily pertain to other units of the same make or model number. Whilst every effort has been made to ensure that all constructional projects referred to in this edition will operate as indicated efficiently and properly and that all necessary components to manufacture the same will be available, no responsibility is accepted in respect of the failure for any reason at all of the project to operate effectively or at all whether due to any fault in design or otherwise and no responsibility is accepted for the failure to obtain any component parts in respect of any such project. Further, no responsibility is accepted in respect of any injury or damage caused by any fault in the design of any such project as aforesaid.

# Stereo start — will anyone be listening?

**A SHORTAGE** of receivers may thwart some listeners now that AM stereo has officially started.

Industry sources confirmed that receivers are unlikely to be generally available until September or October in any quantity.

At present only a small number of manufacturers are geared up to supply the Australian market. Gary Fairweather, Sony's manager of audio products says his company has had AM stereo products stockpiled since January 1984, and expects to move all of it within the next few months.

Pioneer has a limited amount of product in the shops, with more to follow. According to spokesman Laurie Ruddock,

Pioneer is responding to events as fast as possible. However, the development of designs for Australia is going to take at least five months. Eurovox and Alpine are believed to have some limited numbers of products available in Australia as well.

Aside from these companies, there are few other takers. Typical of most companies, Sanyo is adopting a wait and see attitude. Company spokesmen suggested that a decision to go on AM stereo would be made in September or October, by which time it is expected the market

will have settled down.

Industry sources have been quick to blame the Department of Communications for the lack of products. They claim the department gave no notice of the starting date of AM stereo, announcing a February 1 start date on December 15.

But many broadcasters believe the decision was the right one, and the hiatus inevitable. According to Chris Brammall of Stereo AM Australia, an industry pressure group, the DOC decision was handled correctly.

He said manufacturers were

not prepared to introduce products until there was an identifiable market, but a market could not develop until there was something to receive. So DOC had taken the lead.

Predictions are that the drought will last until about September-October. By then many of the sluggish manufacturers will be getting equipment out of the factory. In the interim, it looks as though a small number of companies are going to clean up on the market.

## Satellite telephone first for the west

A REMOTE Western Australian gold mine will have Australia's first telephone service via the domestic satellite.

A \$200 000 agreement between Telecom and Bamboo Creek Management Pty Ltd, signed at the Bamboo Creek mine site north-east of Marble Bar, has come eight months before Australia's first satellite is launched by NASA.

Telecom will establish a six channel customer earth station at the mine to provide telephone, data and text facilities as part of its Iterra Network Satellite Service.

The Bamboo Creek earth station will be erected in time for testing via satellite in October 1985 and is expected to be formally commissioned in January 1986.

Communications will be beamed from a 4.6 metre dish antenna at Bamboo Creek to the satellite in a geostationary orbit 36 000 km above the Earth and then down to Bendigo Victoria, where it will join



Contract for Australia's first telephone service via satellite was signed at the Bamboo Creek mine site in WA.

the National Telecom Network.

Telecom, with a 25 per cent shareholding in Aussat, the government satellite operating authority, will lease transponder number 13 on the second domestic satellite scheduled for launch next October and expected to be operational in January 1986.

Telecom's general manager commercial services, Dr Laurie Mackechnie, said Telecom was able to provide both fixed customer earth stations on two to 14 channel circuits and also a transportable service which was expected to appeal to a number of exploration, resource and pastoral companies in the outback.

"The signing of the Bamboo Creek agreement effectively launches Telecom's Iterra Satellite Services throughout Australia," said Dr Mackechnie.

Call charges will be set at the maximum STD rate, with different payment options available for customers.

## US gets cheaper calls to Australia

GTE SPRINT Communications Corp has begun operational network testing with Australia's Overseas Telecommunications Commission and filed an application with the Federal Com-

munications Commission requesting permission to acquire and operate international facilities for US-to-Australia long distance telephone service.

GTE Sprint expects to offer

service to Australia by the first quarter of 1985, at which time Sprint customers will be able to call all areas of Australia and receive discounts of up to 30 per cent from current AT&T

trans-Pacific rates to Australia.

GTE Sprint is a leading supplier of long-distance telephone service, provided through its network extending more than 75 million circuit miles across the US.

## Computerphone — Telecom vision of the future

TELECOM HAS announced its plan to introduce an all-purpose, easy to use telecommunications terminal for the Australian executive.

Computerphone offers word processor, desk-top computer, data base accessing, videotex, electronic mail and naturally, telephone services in one terminal unit.

It was developed by International Computers Ltd (ICL) of London, who claim the three year contract with Telecom is worth £8m. It is being manufactured entirely in the UK.

Unveiling the preview model computerphone, Dr Laurie Mackechnie, Telecom's general manager, commercial services, listed some of the main features: an intelligent two-line telephone with push button dialling; recall of busy numbers; abbreviated dialling; loud speaking operation; a personal telephone directory that can be quickly displayed for reference; and alternate or simultaneous voice/data calls.

It features a control unit to supervise the following functions: diary and note keeping; word processing; database management system; message pass-

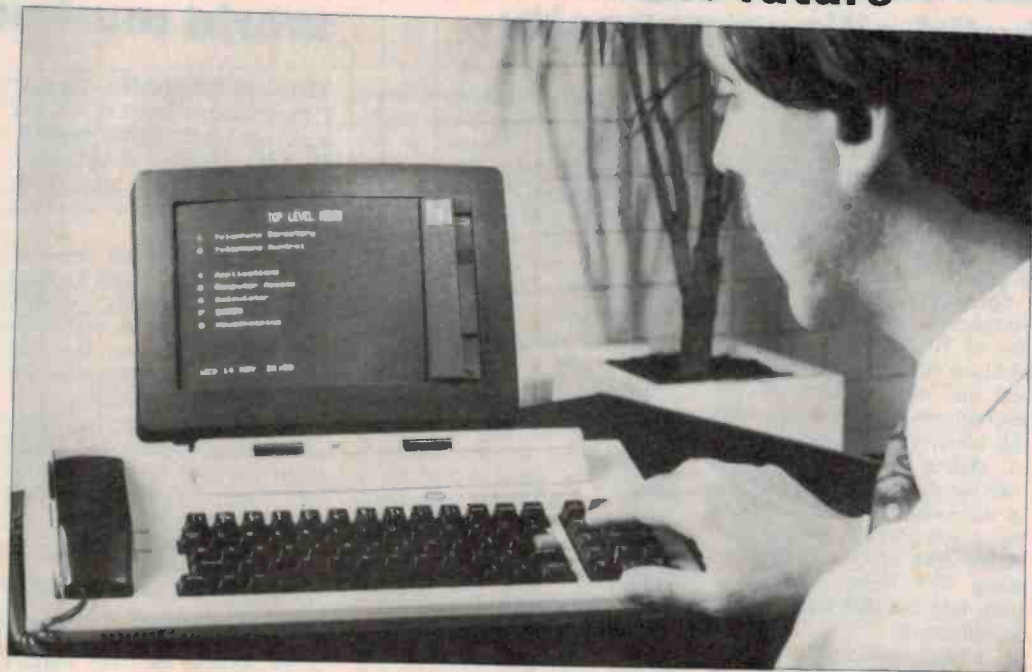

ing; access to viatel or private videotex systems; accessing mainframe computers; calculating and spreadsheeting; business graphics; and outgoing telex via telememo. Printer and coloured screen are optional extras.

"There are other technical

features," Dr Mackechnie said, "but what I regard as prime customer attractions are that it is easy to use, it is not expensive."

Telecom is the first major user of the unit, according to ICL. Andy Roberts, ICL's business centre manager said recently he

expected the Australian market for ICL to be worth over \$100m over the next three years.

Telecom is now commencing training for its technical and advisory staff with the launch of 'computerphone for modern managers' in February 1985.

## Place for locals in OTC

OTC, FOR the first time in its 40 year history, recently hosted an industry briefing aimed at increasing Australian participation in the Commission's capital works program. Using its seven satellite earth stations as an example, OTC's engineering director, John Mattes, indicated to an invited audience how local content in such projects could be increased.

At present five satellite earth stations have some local content in the drive gear boxes, terrestrial transmission interfaces and engineering service circuits. The CSIRO has developed new feeds to provide dual polarization capability at Carnarvon (WA) and Moree in NSW.

Mr Mattes identified reflector panels as one of the first areas in which OTC saw a potential opportunity for local engineering firms. This was especially so for antennas in the Ku band which is a developing market. Feed

systems for these antennas could be manufactured locally, as would sub-reflectors, other wave guide components and guidance control systems.

Another area identified was Klystron power supplies. While there is little scope for the manufacture of tubes, power supplies are well within the range of local industry.

Opportunities also exist for high power amplifiers said Mr Mattes. Discussing ground communications equipment, he said OTC's requirements alone would not support a local industry but that the Australian market could well do so.

Local market participation in FDM multiplex equipment was already quite strong said Mr Mattes, and that this is likely to increase in the future to support the introduction of digital multiplexing.

Opportunities exist for local participation in earth station

management systems. Such systems provide computer based monitoring and control of the station. They include the ability to handle remote, unattended stations; provide analysis to establish original or prime faults; compile periodic reports and provide active control of certain parameters such as EIRP. Local development in this area with customer participation was therefore most appropriate said Mr Mattes.

OTC expects to build six satellite earth stations over the next five years for a cost of around \$11m. As part of this requirement, OTC will need 16 low noise amplifiers (\$0.3m), 18 high power amplifiers (\$5.4m), ground communications equipment valued at \$3.7m, multiplexing equipment totalling \$1.5m, engineering service circuit equipment to the tune of \$1.2m and about \$1.5m of station management systems. The

total value of these projects weighs in around \$25m, but the actual equipment requirements will depend on a number of factors including OTC's traffic growth and the availability of suitable sites.

OTC's immediate needs are for one 18 metre earth station to be located at a site in Sydney. The tender has been split up into components in order to permit greater industry participation.

OTC would consider proposals involving sharing some development costs if they were accompanied by equitable commercial arrangements Mr Mattes said. The current invitation to tender covers a three year period and could extend to: an 18 metre earth station for Sydney, an additional 18 metre earth station, a 13 metre transportable earth station, one or two 13 metre TVRO stations and several standard F stations for Intelsat business services. ▶

## Government urged to build silicon capacity

DR JURI MATISOO, director of the Silicon Technology Department of the IDM Thomas Watson Research Centre in Yorktown Heights, New York has urged the government to build a small scale microchip plant in Australia.

Speaking at a press conference held recently at the University of New South Wales, Dr Matisoo said that it was essential for the development of our microelectronics industry that this country should have a pool of skilled personnel familiar with the design and construction of microchips. While Australia has a considerable skilled base in the area of chip design we, along with many other countries, lack the skill necessary for manufacture.

Dr Matisoo is in Australia to look at work currently being carried out by the Joint Microelectronics Research Centre. JMRC is an organization set up by the University of New South Wales

and the Royal Melbourne Institute of Technology. It was originally set up following a \$2 million grant from the Federal Government in 1982. IBM later weighted in with a promise of \$1 million over the next four years.

Current projects at JMRC include the creation of the world's most efficient silicon cells, high gain transistors and development of extensive CAD software.

Professor Graham Rigby, head of JMRC, agreed with Dr Matisoo that an experimental/research IC plant would be a useful addition to Australian capabilities. Currently experimental plant was estimated at to large commercial plants for fabrication which is expensive and time consuming.

Set up cost for a small experimental plant were estimated at around \$10 million, versus about \$50 million for a full scale commercial one.

## Illegal chips on world market

THE MITSUBISHI Electric Corporation is keen to trace a series of reject M5K4164ANP-15 64K dynamic RAM chips illegally released onto the world market by a Japanese toy manufacturer.

The chips, which number around 500 000, failed to meet Mitsubishi Electric's quality control requirements and were sold unbranded to the toy manufacturer, purportedly for a decorative application.

The company then had them overprinted with the Mitsubishi logo, and part number and re-sold them to several trading houses. From that point, the chips have found their way around the world.

The problem for the ultimate end-users of the rejects is that they don't carry the usual guarantee because the chips weren't bought direct from Mitsubishi Electric.

According to Mr Jon Spence a spokesman for the Australian

arm of the company, none of the rejects has yet been discovered in this country, and a large proportion has since been recovered in the United States and elsewhere.

He said that the chips could appear a little dirty from lengthy storage and carry 841809 and 842105 batch marks.

Spence estimated that the toy manufacturer netted a cool \$1 million profit from the illegal sale. However, his enterprise is unlikely to pay off because he is now being sought by Japanese authorities.

Anyone finding the chips should contact Jon Spence at Mitsubishi Electric Australia Pty Ltd, 73-75 Epping Road, North Ryde, NSW 2113. (02)888-5777.

## BRIEFS

The Measurement Control Division of Electrical Equipment Limited, after several years at Arncliffe, has moved its head office to North Ryde in Sydney.

The new premises will provide extra space for the company's design, manufacturing and service activities. Sales and instrument hire will be conducted from the new head office as well as from branches in other states. The new office is at 8 Lyon Road and the telephone number is 888-9000.

The PA People at Enfield in NSW has started a concert production division to be managed by Peter Twartz and Chris Dodds. Mr Twartz, who has worked in Europe and the US as a production manager, has been a sales engineer at Klarion. Mr Dodds, recently manager of PA People in Canberra, has experience in television and live sound.

Rank Electronics has announced that it will be a supplier of videotex equipment, representing Salora of Finland and Xyllyx of the United Kingdom. Salora manufactures videotex adaptors, desk terminals and editing terminals. Included in the Xyllyx range of equipment will be a coin operated videotex terminal. These intelligent terminals, which can calculate computer time, telephone charges and frame costs, are already in use in the UK and Germany.

Australian computer manufacturer, Webster Computer Corporation, was the only Australian high technology company represented among the 300 exhibitors at the Dexpo West computer show held recently in Los Angeles. Dexpo is a DEC and DEC compatible computer show held twice a year in the US. Managing director, David Webster, said the company's new disc controller attracted considerable interest at the show. The dual-height disc controller is the only one on the market to implement DEC's new Mass Storage Control Protocol.

Tubemakers Process Controls has recently established an office in Tasmania at 67 Lampton Avenue, Moonah, telephone (002)72-6931. David Steedman who has been appointed sales engineer was previously a sales development supervisor with William Adams.

R H Cunningham Pty Ltd has appointed Philip Lawson as its new managing director. Mr Lawson has a science degree and has specialised in developing markets both in Australia and overseas. In another move, David Mason has been appointed to the board as director of engineering. Mr Mason has been with the company for over 12 years. James Cunningham who has established the rental area, particularly in the conference market through the associated company Conference Technology, now becomes deputy chairman of R H Cunningham.



## Help applying microelectronics for Australian industry

THE CENTRE for Microelectronics Applications (CIMA) has announced its readiness to offer Australian industry wide-ranging assistance in the application of microelectronic technology to both existing and projected products.

It is widely reported that the use of microelectronics is fundamental to many of the processes and products of Australian manufacturing industry. It is also the cornerstone of the information revolution in which we are currently involved.

Many countries of the world have identified this technology as being essential to the survival and progress of indigenous manufacturing industries.

According to CIMA Australian industry has been slow to both recognise and embrace the philosophy of survival through microelectronics for a number of reasons, some of those being lack of awareness of the scope of the technology, particularly as it applies to their products, current and future; concern at the cost of R&D and the ability to recover those costs in such a small market; the conception that 'state of the art' technology requires large volumes to ensure an adequate return on investment; and the often quoted

'technology cringe', that is, a conviction that Australian business is ill-equipped to compete against the technology giants in America and the Far East.

To address these concerns, RMIT and Technisearch Ltd have been contacted by both the Federal and Victorian State Governments to provide a means whereby the skills and knowledge available within these organisations is made available at minimum cost to Australian industry.

CIMA has been established to provide this service, through a series of seminars and workshops designed to provide management and technology awareness, project developments, and the transfer of the latest microelectronics design techniques, through assistance and guidance in prototype development workshops.

A comprehensive information service, through access to text and data held in libraries throughout the world, is a bonus facility which is offered to participants in the programmes and industry at large.

For further information contact Trevor Andrews, CIMA, Kay House, 449 Swason St, Melbourne.

## Electric vehicle endurance competition

THE AUSTRALIAN Electric Vehicle Association Melbourne Branch is inviting participation in the 1985 'Electrathon' events to be held at VFL Park, Wellington Road, Mulgrave, Vic on the following dates: 19 May 1985 and 1 September 1985.

Scrutineering will commence at 11 am and the race will start at 1 pm on each of the above dates.

Family and friends are invited

and the BBQ advised. There is no entry fee for spectators, the more the merrier.

Novices and professionals alike are encouraged to enter the events. Details of prizes are yet to be announced.

Regulations and entry forms are available from The Secretary, Australian Electric Vehicle Association, 4th Floor, 126 Russell St, Melbourne, Vic 3000 (03)63-7263.

## Brilliant On Your Bench Light On Your Budget



**5½ IS ONLY THE START.** This Keithley starts by giving you versatility. Add 1  $\mu$ V, 1 m $\Omega$ , 1 nA sensitivity and 0.013% DCV accuracy to 5 full functions.

**5½ + EXTENDED PERFORMANCE.** The 197 offers fast autoranging, TRMS AC to 100 kHz, 6 current ranges, automatic 2/4 wire ohms, and 220,000 count display, with full annunciators. Digital calibration locks in this performance.

**5½ + CONVENIENCE.** The 100 point data logger lets you store readings at six different rates or by manual trigger. RELATIVE reference lets you zero out any on scale reading. There's also MIN/MAX reading hold. For portability, the 197 can be ordered with a rechargeable battery option.

**5½ + IEEE - 488 + ANALOG OUTPUT.** Put the 197 on the GPIB with range programmability on volts and ohms, talk/listen capability, trigger, SRQ, and other commands. Order the IEEE option alone or with the isolated analogue output.

**5½ + VALUE.** Add it all up. We think you'll agree the new 197 is a highly sensitive, accurate, and versatile tool that you should put on your bench.

# KEITHLEY



SCIENTIFIC DEVICES AUSTRALIA PTY. LTD.

VIC 2 JACKS RD, SOUTH OAKLEIGH, 3167  
PHONE: (03) 579 3622 TELEX: AA32742

NSW OFFICE 2, 35-37 HUME ST, CROWS NEST, 2065  
PHONE: (02) 43 5015 TELEX: AA22978

SA 31 HALSEY RD, ELIZABETH EAST, 5112  
PHONE: (08) 255 6575 TELEX: AA88125

# BMAC — WE'LL BE FIRST TO USE IT

The introduction of satellite broadcasting to Australia will change the face of home entertainment forever. It will also bring a new broadcasting standard to TV, the first for thirty years.

AUSTRALIA USUALLY copies its broadcasting arrangements from overseas countries. It's a method of doing things that has worked well in the past — enabling us to maximise the service we get from radio and TV, with the minimum

R&D investment. On the down side, it means we miss out on the excitement of being on the leading edge.

But that's changing. The countdown of Aussat 1, due for launch in mid-'85, is on course, and on time. It will revolutionise

life in rural Australia, and it will bring the cutting edge of broadcast technology into transmission stations across the country.

The reason for all the excitement? After much agonising, the Department of Communications (DOC) has decided to take Australia into the forefront of broadcasting technology by specifying the BMAC standard for TV and radio broadcasting from Aussat. Australia will be the first country in the world to use it, so if BMAC has problems they will be met and solved on the Australian outback.

Jon Fairall

## Origins

Up until now, all TV broadcasting in Australia has been done using the PAL standard. The origins of PAL can be traced back to the original 405 line signal broadcast by the BBC in 1936. The current standard was formalised during the 1950s.

All through the evolution of television the principle has been that the origination of new TV services should not disadvantage people who have invested in the old technology. So, when colour was introduced, people who had black and white sets could still receive the signal. The colour was a bonus added to, not instead of, the existing service.

This principle has been applied to all public broadcasting in just about all areas of development. It's still at work today. For instance, the new AM stereo radio format is completely compatible with existing AM mono receivers.

This is an entirely proper and correct way of doing things. However, it does mean that new technology can be placed in a straightjacket. It seems strange that TV, a gee whizz, hi-tech medium if ever there was one, should be bound by a set of standards three decades old. But such is the case.

Satellites were not going to be any different. The original scheme was for a



A large commercial installation like this will send TV signals up to Aussat. It can also receive signals sent to the studios via the satellite.

satellite system using PAL and capable of doing DBS (direct broadcasting by satellite) over the whole of the Australian interior. In other words, a scheme entirely compatible with existing standards.

But when DOC engineers started experimenting with the system, problems started appearing. It quickly became apparent that, to bring in a PAL signal from a tiny 30 watt transmitter hundreds of kilometres overhead was no mean feat. When technical requirements met economic restraints, it rapidly became impossible.

### Pal problems

The biggest single consideration in designing satellite systems is the noise constraint. Because of the great distance involved and the small power of the transponder on the satellite, to receive satellite signals is an exercise in picking faint signals out of the noise.

Unfortunately neither PAL nor its precursor NTSC is designed for use in really noisy environments. There are a number of inherent problems. For a start, they transmit their colour or 'chroma' information on a subcarrier, which is frequency modulated. Frequency modulation suffers from a noise triangle in which the higher the modulating frequency, the greater the noise. But the response of the eye to noise (snow) on the screen has an inverse response, i.e., it's easier to see low frequency noise.

Both PAL and NTSC transmit the chroma subcarrier at the high frequency end of the channel, where it's vulnerable to noise and then demodulates it to low frequencies, where it's easy to see!

PAL and NTSC also have a nasty habit of getting their signals mixed up. Under adverse conditions the chroma can get into the luminance signal. (The luminance signal carries the black and white information. Both chroma and luminance are necessary to create the picture.) The reverse interference process can also occur. These phenomena are known as 'cross luminance' and 'cross chrominance'.

PAL and NTSC have another problem that irks. Blanking takes up too much time. Blanking is the period during which the cathode ray tube is turned off while it retraces to the correct position on the screen. Over 20% of the total transmission time of a PAL signal is taken up with this activity, that is, taken up with transmitting a blank screen.

In the normal course of events we can live with these problems. Modern techniques have done wonders with noise suppression. The waste time in the blanking can be used for captions of one kind or another. But satellites present problems of a different order of magnitude.

### MAC

As it turns out, the fact that compatibil-

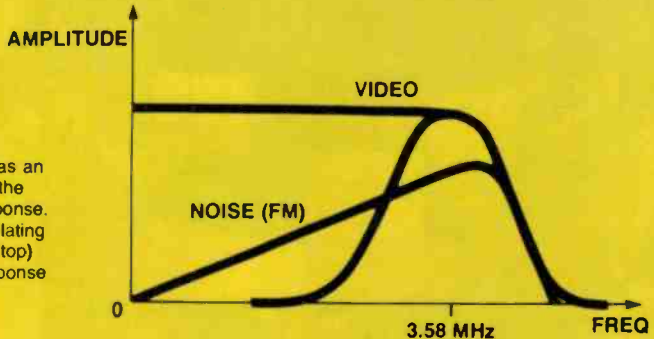
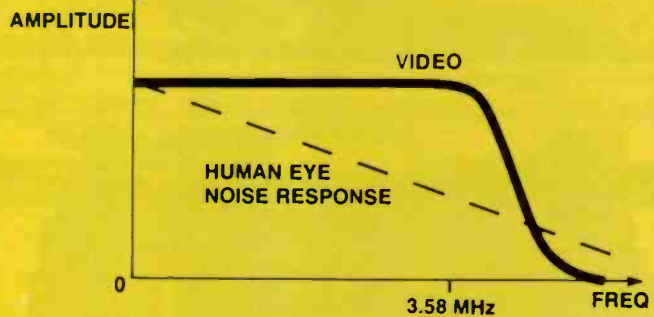
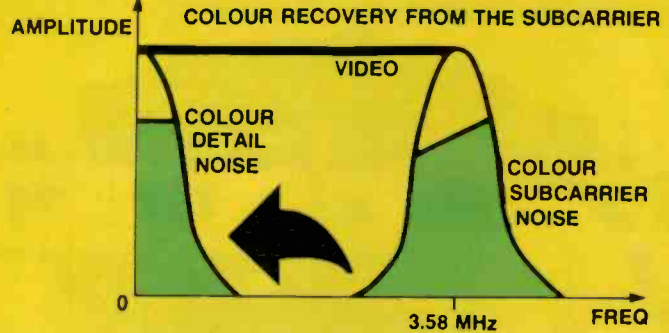

Figure 1: FM noise has an opposite response to the human eye noise response. Unfortunately demodulating the colour subcarrier (top) makes PAL noise response worse.

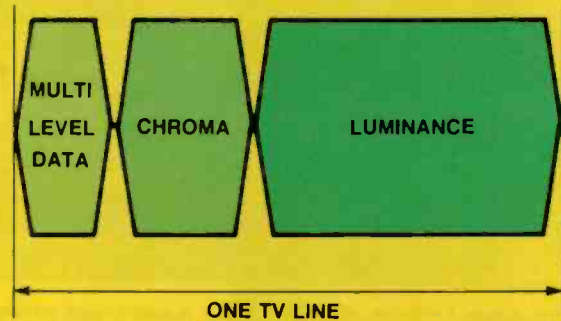
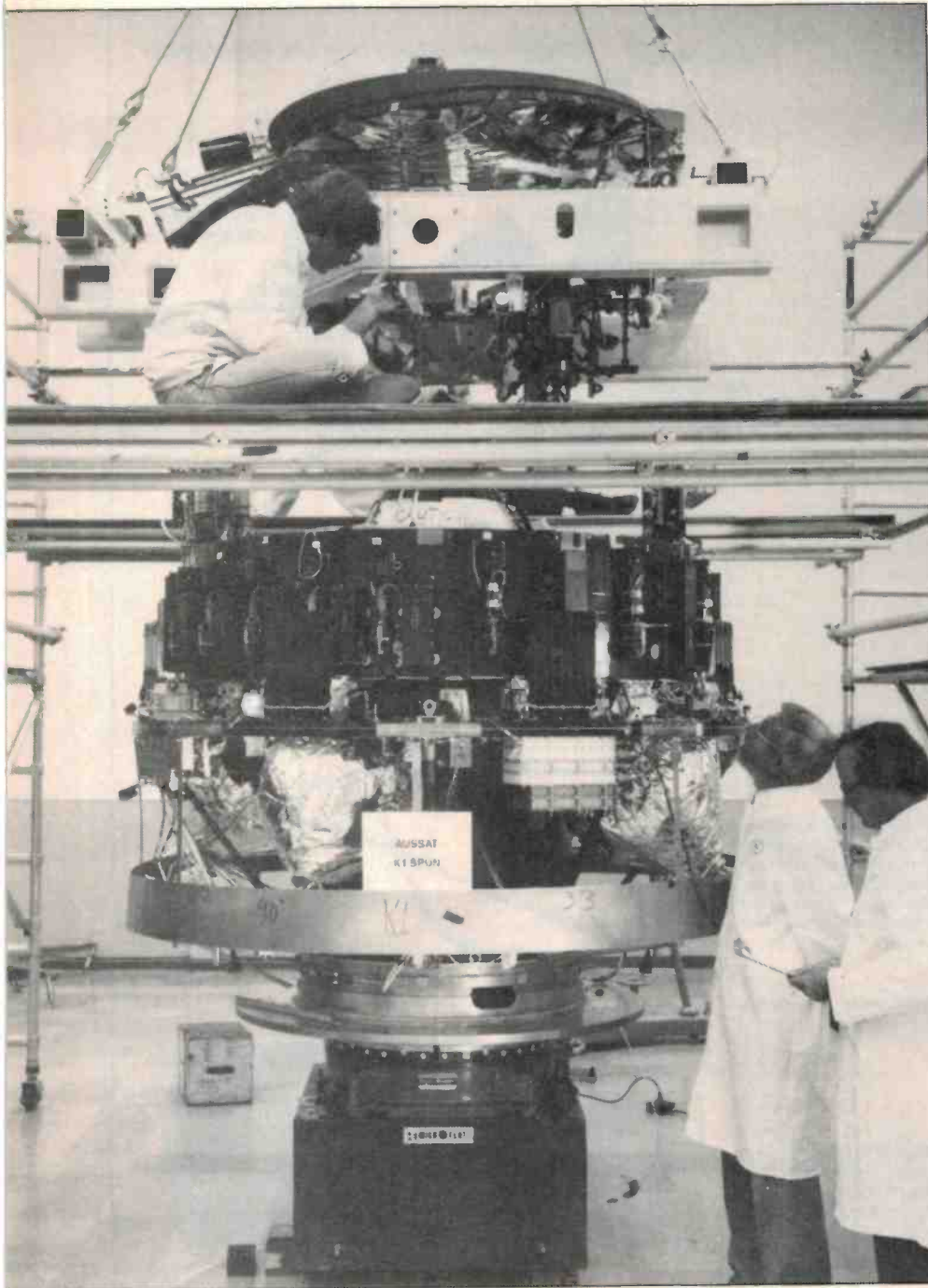

Figure 2: A single line of BMAC data. The chroma information needs two lines for complete transmission. Six audio channels plus one data channel can be contained in the multi level data signal at the start of the line.

	FREQUENCY MULTIPLEX	TIME MULTIPLEX
BASEBAND	A	B
RF	D	C

Figure 3: The four different ways of encoding the sound channels in the different MAC systems.



**Preparing Aussat 1.**—The first Australian satellite, Aussat 1 nears completion at the Hughes Aircraft plant in Los Angeles. The outer skin of the satellite will consist of solar cells to provide power for the electronics. In position the spacecraft will spin on its long axis to provide stability. There is a small despun platform at the top where the earth-pointing antennae will be mounted.

ity is not economically possible with satellite broadcasting is not as much of a problem as it might have been. Firstly, by their nature, satellite systems in Australia will reach an untapped market, so people don't have to junk obsolete equipment. Secondly, the advent of monitors and VCRs has meant that access to RGB input is more important than strict compatibility with any standard.

So, what should we require of a satellite standard? Above all else, it should be

cheap. It should also be pretty much immune to noise. It would be nice if it had the ability to carry a decent wideband sound channel. From the broadcasters' point of view it would be even nicer if it had the ability to be scrambled, so that they could have some control over who received the signal. This last requirement may not be endorsed by the viewers of course!

Looking at this wish list, one is inclined to think digital. The problem with a com-

pletely digital solution is just one of cost. It's too expensive. Even with the help of VLSI techniques it's unlikely that digital transmission will be cost effective before the 1990s.

The answer to the problem was first proposed by engineers at the British Independent Broadcasting Authority. The IBA came up with a system called Multiplexed Analogue Components, or 'MAC' for short.

MAC is a hybrid digital/analogue time-division multiplexed system, in which the first third of each line is taken up with the chroma information and the second two thirds with luminance.

Complete chroma information is sent over two lines. Information from the first line needs to be stored until the second has been decoded. Naturally, both signals need to be compressed in time, with attendant widening of the bandwidth required to transmit the information.

Sound information is sent in encoded form during the first nine microseconds of each line. There is also provision for a data channel.

In this system sync is provided by a highly redundant digital word at the start of line one of the TV field, and then by a short burst at the beginning of each subsequent line. The system is so good that full picture lock up has been demonstrated with 0 dB signal-to-noise ratio! As a bonus, syncing the picture takes up no more than 0.002% of the total picture time (as opposed to 20% with PAL).

To date, MAC has been produced in five different versions: A, B, C, D and E. They all differ in the way they handle the sound channel. Both AMAC and DMAC frequency multiplex data and audio channels. CMAC is a time multiplexed version. EMAC is a brand new version being developed by Philips, about which no details have yet been released.

### **BMAC**

This is the version of MAC developed by Digital Video Systems in Canada. DVS is a subsidiary of Scientific Atlanta, a US-based corporation that acquired the North American rights to MAC from the IBA. The British company Plessey owns half of Scientific Atlanta.

So, in 1983, when Australia's DOC was casting around for an alternative to PAL, Plessey (Australia) was well placed to offer a system, albeit an untried one.

BMAC multiplexes audio channels at baseband (normal video frequencies) and inserts them into the horizontal blanking period. It uses a four-level digital signal, which makes it possible to contain the bandwidth to 6 MHz but still provide up to six audio channels plus one data channel for command and telemetry.

The audio channels in BMAC were especially designed to be compatible with the very best hi-fi sound available. The system was designed by Dolby with vari-

able pre-emphasis and a delta modulation system.

Pre-emphasis is a fairly standard form of noise reduction in audio engineering. It takes advantage of the fact that the noise spectrum of an FM signal is triangular, i.e., increases linearly with frequency. Before the signal is transmitted, the high frequency component is boosted (i.e., pre-emphasised).

When the signal is received the reverse process takes place and the high frequencies are attenuated by exactly the same amount as they were originally boosted (de-emphasis). In the process the high frequency noise component is also attenuated, so contributing to an overall increase in the signal-to-noise ratio.

In conventional FM broadcasting the amount of pre-emphasis is set by international agreement, and is optimised for typical audio signals with typical noise distribution. This does represent a compromise, however. A better, but more complex solution is available when noise performance is exceptionally important (as here). This is variable pre-emphasis. The signal is sampled before it is transmitted and the amount of pre-emphasis set accordingly. Naturally a control signal also needs to be sent with the audio, in order to set the de-emphasis at the other end.

Delta modulation is a digital system rather like the more conventional pulse code modulation, except that the code does not stand for absolute values of the analogue signal waste form, but for changes in the value of the wave. So instead of sending a multibit word to describe the absolute value of a sample, it is only necessary to send a stream of 0s and 1s to signify whether the signal is increasing or not. Although it is very efficient, this system is limited most strongly by the slow rate of the incoming signal.

## The downstation

The DOC has released details of the ways it is prepared to see BMAC used in downstations. One of these is the simple DBS situation.

People wishing to get into DBS will buy a 1.5 m dish antenna, a low noise converter to sit at the focal point of the dish and a satellite receiver.

This latter will contain a Plessey Baseband Processor Unit (BPU), which converts BMAC into RGB, and makes the six audio channels available. It will also have a PAL modulator to turn the RGB plus two audio channels into a high quality PAL stereo signal.

Other schemes will allow an entire community to share the cost of a satellite receiver installation. Under these self-help schemes the community will be allowed to feed the reconstituted PAL signal into a small transmitter for local broadcast.

Another type of self-help project is the community cable distribution type system, intended for situations where the receiver

sites are very close together, but also very isolated as a community. A collection of houses on a remote property would be a prime example. In this type of application, the satellite signal is simply down-converted and then ducted through cable to each receiver with requisite amplification and splitting.

This amplification and splitting looks completely transparent to BMAC, so that each receiver will need a baseband converter for turning BMAC into PAL, or better still, using it to feed an RGB signal into a monitor.

In fact, this is an ideal situation, involving the minimum of modulation and demodulation. It also illustrates one of the prime advantages of BMAC: its compatibility with cable. It can exist within the standard channel bandwidth, so it doesn't need any replanning or reallocation of TV channels.

## Manufacturing

The market for BMAC is the 650 000 Australians who don't have access to decent TV signals at the moment. To these, add those people in the rest of the country who might be interested in pulling in satellite signals for some variety. At a recent industry seminar it was suggested that this would translate into a possible market for 100 000 units.

Prime beneficiary of this market will certainly be Plessey (Australia), which holds the rights for the development of the BMAC BPU. Plessey intends to manufacture complete downstations at its plant at Meadowbank NSW, and to sell BPUs to any other manufacturer who wishes to buy them for inclusion in his own downstation design.

Plessey has suggested a price of around \$450 for the BPU. According to Plessey Managing Director Walter Fielder Gill, Plessey has no intention of capitalizing on its monopoly situation. According to Fielder Gill, the company has a commitment to the government to make rural TV as cheap as possible.

Ivan Trayling, Plessey's Business Manager, has given a categorical assurance that no equipment manufacturer dealing with Plessey will be penalised in terms of price or delivery. He gave an assurance that the development programme for the production version of the BMAC processor unit was on time and on schedule, with first delivery in October 1985.

Within the broadcasting industry support for BMAC has been lukewarm. Engineers in TV stations are pleased by BMAC's technical capabilities but worried by the cost of transmission boards. Only a few months before TV stations must begin installing them there are no firm prices available for the boards, but figures in excess of \$350 000 have been mentioned.

The recent collapse of one of the biggest prospective users of BMAC technology in the USA has also caused a few sleepless

nights at the TV stations. Plessey pricing has been based on the assumption of huge production runs in North America. If these do not eventuate, or are delayed for some considerable time, there is a fear that Plessey may have to recoup some of their costs in Australia. If that happens BMAC could start to cost us all a lot of money.

Within the manufacturing industry, reaction to these pronouncements has been one of extremely cautious optimism. There was not much support for the view that complete earth stations will cost only \$1520 (a price suggested by the government), but there does seem to be a belief that systems will be available for the minimum possible price. Plessey is talking about \$850, excluding the cost of a low noise amplifier and dish antenna. A realistic total figure is probably in the vicinity of \$2000.

Many local manufacturers are known to be excited by the opportunities offered by BMAC. Rockwell-Collins in Melbourne, for instance, is studying the viability of a manufacturing operation. Smaller manufacturers are also climbing on the bandwagon with interest in manufacturing various components. It is likely that the majority of antennae available in this country will be made in this way.

Overseas manufacturers are also interested. Toshiba has plans to buy BMAC BPUs in Australia. It will export them to Japan for inclusion in satellite downstations to be shipped back to Australia.

Since BMAC is also to be used over North America it is quite likely that many Australian companies will be interested in the possibility of exporting equipment to the giant US market. For once they are likely to be ahead of the competition. ●



# Space age communications for all Australians.

AUSSAT is Australia's National Satellite System. From its launch in 1985 the AUSSAT System will enable many new advances in telecommunications. TV transmission to remote areas. Extended communications links with outback homesteads. Flexible emergency services beyond current alternatives. Dramatically improved education facilities especially in remote areas. Expanded TV networks links. High speed data transfer, video conferencing and improved traffic in Australia's business communications.

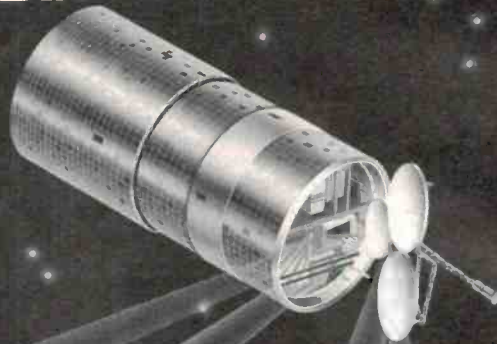

**AUSSAT**

Australia's National Satellite System

## Plug into 'Eveready' rechargeables.

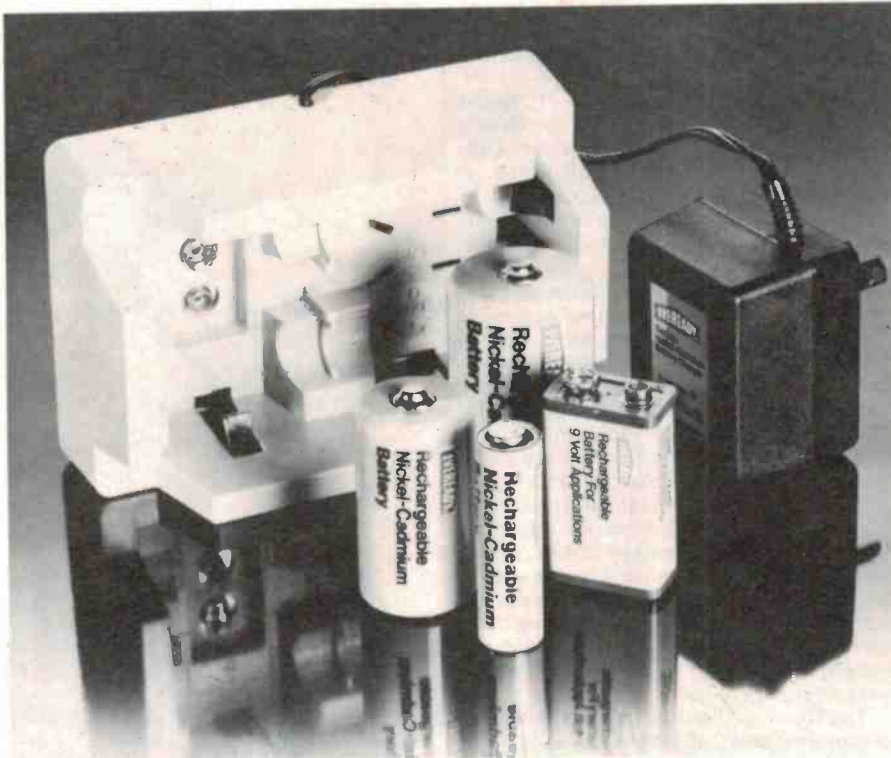

Our rechargeable range, in popular sizes, can be charged up to 1000 times on the new model ACC50E Charger, thus offering an extremely economical power source to the heavy-battery user. Especially ideal for photo-flash, movie cameras, tape recorders, transceivers and electronic games and toys.

Please don't hesitate to call for further information.

**EVEREADY**

### Rechargeable Nickel-Cadmium Batteries.

Union Carbide Australia Limited,  
Battery Products Division  
30/40 Harcourt Pde, Rosebery,  
Phone 667 0444.

**SALES OFFICES:**

Sydney: Cnr Hayes Rd & Dunning Ave,  
Rosebery, Phone 693 2666.

Brisbane: 47-49 Sherwood Rd, Toowong,  
Phone 371 6877.

Adelaide: 121 Greenhill Rd, Unley,  
Phone 272 0611.

Melbourne: 14 Queehs Rd,  
Phone 26 1241, 26 2332.

Perth: 31 Outram St, West Perth,  
Phone 321 2926.

**UNION  
CARBIDE**

Eveready and 'Union Carbide' are registered trade marks.

L660

# Pace unveils AM stereo car cassette



Concord Auto Hi-Fi, has recently released its latest model, the HPL 550 car radio cassette player.

The new AM stereo model uses the Motorola system as recommended in Australia for AM stereo broadcast by the Federal Government.

The deck also includes FM using an exclusive Concord feature called FNR, an FM switchable noise reduction option which reputedly gives clean, clear FM performance in areas previously unable to get a clear signal.

The cassette section has more sophisticated features than are

available on many home cassette decks. There are three built in noise reduction systems, Dolby B, Dolby C and DBX, so that tapes prepared for high fidelity listening at home will be quite compatible.

The cassette section is further enhanced by using a dc-servo drive motor for improved speed and wow and flutter control, an amorphous core matched-phase tape head is standard and which the manufacturer claims will last the lifetime of the unit.

The built in amplifier is rated at 25 watts per channel and can be switched to provide two channel or four channel operation with a built in fader control.

At \$939 it is not cheap but the owner can be consoled by the thought of a technically advanced deck and a year long warranty.

For further information contact Pace Enterprises, 4 Clarendon St, Artarmon, NSW 2064. (02)439-8900.



## Ultra compact camera

ALONG WITH VCRs, sales of video cameras are increasing. Sharp's research has suggested to them that customers are interested in a light weight and compact video camera, which Sharp has managed to miniaturize in the XC-54.

Its main features include its design and weight — 0.72 kg, an f 1.5 3 x (10 ~ 30 mm) zoom lens with auto iris, a four position colour temperature selector, through-the-lens (TTL) optical viewfinder, LED indicators for battery alarm, recording start and under exposure, and detachable condenser microphone amongst many other things. It also uses the Newvicon pick-up tube.

## Easy automatic video camera

JVC HAS released recently yet another new model video camera — the GX-N7.

By completely automating all major camera functions, this model frees the user entirely to the creative side of video.

As well as being able to record with a subject illumination of only 10 lux, the three basic operations — focus, white balance and exposure control, are all fully automated. When colour temperature of available light changes a video camera needs to be readjusted for accurate colour reproduction. With most cameras, recording must be interrupted for this adjustment, but the GX-N7 adjusts itself continuously and automatically.

The 6.1 power zoom lens of

the GX-N7 can be replaced with lenses from a 35-mm camera. An appropriate adaptor is available from JVC for Canon, Nikon, Pentax, Olympus or Minolta.

Other features of the GX-N7 include: 1/2" Newvicon tube; lightweight compact size (weighing only 1.1 kg); automatic iris with BLC setting and 6.1 power zoom lens with macro; audio/video fade in and fade out (white fade); built in one point stereo microphone; compatibility with VTRs from other makers; adjustable electronic viewfinder.

For more information, contact Anthony Toope Hagemayer (Australasia), 5-7 Garema Ct, Kingsgrove NSW 2208.



## AM stereo monitor tuner



THE NEW AMX 1 is a Motorola system stereo version of the AM 102 broadcast monitoring tuner. It features an audio response up to 12 kHz (-3 dB) with two switchable 9 kHz deep-notch Cauer filters (whose responses are only 2 dB down at 8 kHz) to ensure excellent filter-

ing with minimal HF loss. Carrier and modulation fail alarms, balanced line output amplifiers with 40 ohm source impedance and a balanced low noise aerial system (supplied) complement this tuner which should have wide appeal among broadcasting organisations. When used in

conjunction with the Audio-sound Laboratories PM 1 stereo programme monitoring unit, the AMX 1 forms a complete AM stereo off-air receiver with modulation monitoring.

Also, shortly to be released is a domestic version of this tuner without alarms and balanced

output amplifiers but retaining the other technical features such as the deep-notch filters, switchable selectivity etc.

For further information contact **Audiosound Laboratories, 148 Pitt Rd, North Curl Curl, NSW 2099. (02)938-2068.**

## Monitor-look colour

SANYO HAS released a new range of 'monitor-look', colour televisions with remote control.

The 34 cm CPP-3010V and the 43 cm CPP-5010V models feature feather touch tuning systems which scan up or down channels. Up to 12 channels can be programmed for fast and simple selection of VHF and UHF channels.

These units feature a sleek,

monitor-look design and a smoked glass screen filter for comfortable, glare-free viewing.

These new models also feature 100 per cent solid-state circuitry, a handy infrared remote control unit which fits neatly into the body of the unit and audio/video, input/output terminals to provide great versatility.

Other features include a built in dipole antenna, earphone

jack and digital up/down volume control for precise adjustment of sound level.

Both these models are available from selected electrical retailers and department stores for around \$499 and \$649 respectively.

For further information, contact **Sanyo Australia Pty Ltd, 14 Mars Road, Lane Cove NSW 2066. (02)428-0822.**



## All in one VHS home movie system

NATIONAL has developed a single system VHS filming and recording video unit, the camcorder system.

The camcorder system is a sturdy, lightweight shoulder-frame (WV-SF1N) which has been specially designed to 'dock' together National's NV-180A porta-pak with either of its A series cameras as a single system. The frame is designed so that a tape can be inserted/ejected, the battery can be replaced, playback can be achieved through a TV, without having to remove the porta-pak. All functions can be maintained including an alternative and handier position for the WVPA2NA title keyboard.

The comfortable, professionally styled shoulder pads fit most adult body sizes. Other features

include a low light four hour camcorder system with electronic viewfinder, advanced direct image auto focus and the added benefit of versatile operation to conventional use.

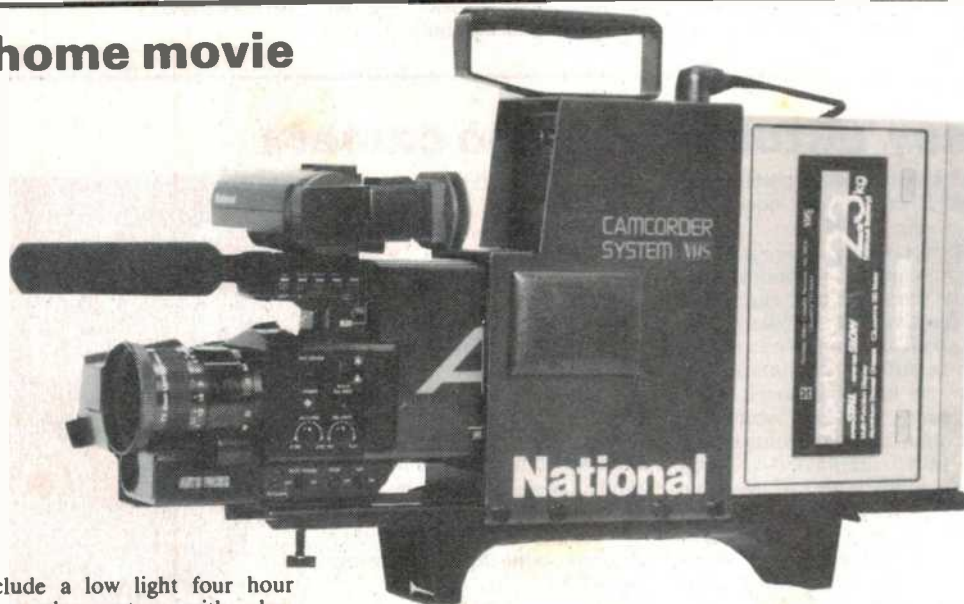

To complete the system National has introduced a carrying case with durable aluminium finish.

For further information contact **National Panasonic, 95-99 Epping Rd, North Ryde NSW 2113. (02)887-5315.**



# SONY

# DIGITAL DAWN.



The world is waking up to the ultimate sound experience that only digital perfection can deliver.

And Sony's ES Series are the top of the range digital components.

The CDP-501ES Compact Disc Player with multi-function cordless remote control, featuring volume control.

The TA-F444ES integrated amplifier gives you the outstanding dynamic range of over 120dB and the channel separation of over 100dB (at 1KHZ) that digital audio demands.

The ST-S444ES FM stereo/AM tuner, the original direct comparator quartz frequency synthesis tuning for striking

S/N ratio of 88dB (stereo).

The TC-K555ES-MkII cassette deck, with three head laseramorphous record and playback heads plus closed loop dual capstan tape transport, assure the wide dynamic range and reduced modulation noise.

The SEQ-555ES programme equaliser automatically customises music to suit the

room and the full function wireless remote commander adds convenience.

APM-55W speakers, (from the APM range), with flat square diaphragms for clean, powerful sound.

For the best in sound it has to be digital and it has to be the Sony ES series.

**SONY DIGITAL AUDIO DEALERS:**  
**BRISBANE,**  
Reg Mills Stereo 391 5606;  
**MACKAY,**  
Mackay Stereo Sales 57 7512;

**SYDNEY,**  
Bery's Radio 969 3830,  
Chatswood Colour TV 411 2090,  
Sydney Hi-Fi Centre 29 1082;  
**CANBERRA,**  
Kent Hi-Fi 82 2874;

**MELBOURNE,**  
Beta Audio Video 509 6846,  
Encel Electronics 428 3761,  
Interscope Video Centre 63 3086;  
**ADELAIDE,**  
Grenfell Plaza Hi-Fi 51 5017;

**PERTH,**  
Audio Equip 330 3397,  
Vince Ross Audio 321 2644.

# AVERAGE MUSICIANS DON'T OWN A CX5M.

# THAT'S WHY THEY'RE AVERAGE MUSICIANS.

The Yamaha CX5M is an extremely versatile computer designed especially for musicians.

And especially for those musicians who are particularly serious about synthesised music.

Professional musicians, sound engineers, composers, arrangers and the like.

The CX5M is one of the new generation MSX computers, the very latest in software and hardware technology.

When connected to your DX7 synthesiser (other synths. subject to available software) the CX5M makes creating the sound you want and programming the sound you want considerably

easier. It can be used as a sequencer, edit suite, to compose pieces of music, or operate as a musical instrument independently.

In fact it has 46 synthesised voices already built in.

And all the voices are generated by the superb Yamaha FM system.

Complete with a 3 piece software package, the CX5M also features a built-in MIDI interface, which allows the computer to talk to any MIDI equipment such as synthesisers, drum machines, effects and sequencers.

And the regular arrival of new Yamaha



programmes ensure that its applications to your music are endless.

Of course, the real benefit of all this is that the Yamaha CX5M allows you more time to enjoy playing your music than wasting it programming your synthesisers.

It also converts to a standard computer on which you can play Space Invaders at the push of a button.

But we think that most musicians will use it with a different score in mind.

For more information about the Yamaha CX5M music computer, please fill in the coupon

below and send it to Rose Music, 17 Market Street, South Melbourne.

Yes, I would like to know more about the Yamaha CX5M.

Name.....

Address.....

Postcode.....

Saatchi Vic/RM 6235

**YAMAHA**

# TREATS IN STORE

## — from the Sony D50 CD player



### SONY D50 CD PLAYER

Dimensions: 127 mm (wide) x 401 mm (high) x 134 mm (deep)  
Weight: 590 gm

Supplementary ac/dc Adaptor: Sony model AC190A 240 volts input, 9 volts dc output at 800 milliamps

Dimensions: 100 mm (deep) x 540 mm (high) 570 mm (wide)

Weight: 650 gm

Manufacturer: Sony Corporation, Tokyo, Japan

Anticipated price: \$399

Good things come in small packages so the saying goes. The Sony D50 CD player is certainly miniature but a little investigation reveals many things. With a little Sony mastery it surpasses expectations of hi-fi small or large — while still remaining a bit of a Sony mystery.

**Louis Challis**

IN LATE NOVEMBER 1984 Cathy Gray, the editor of *Sonics* magazine told me with some excitement that a friend of hers had just returned from Japan that day and had brought back the first example of the new Sony D50 miniature compact disc player.

She asked whether I would like to test it and review it before her friend left later that day for other ports?

Naturally I said "Yes" but as is so often the case the promised load did not eventuate.

It was not till mid-December during a visit to Japan that I first caught sight of the D50 as it was pushed over the conference room table for me to examine at Sony's head office in Tokyo.

What I examined was substantially more than just a neat, technically sophisticated and extremely marketable piece of equipment. I perceived what will be the storm

troops of a revolution which has gained such a degree of momentum to ensure the early demise of its main opposition.

It is now only slightly more than two years since I first reviewed the Sony CDP101 compact disc player, which was a 'state of the art' development. Of course, anything that is 'state of the art' has to have a 'subscripted date'. The technological developments are now happening so rapidly and embody such tremendous advances, that this year's 'state of the art' advance becomes next year's standard model and is likely to be a superceded model less than a year later.

So it is with the first generation of CDs which you can now buy at auction for much less than half the original price and which you can pick up in Singapore and Hong Kong for unbelievably low prices.

The reasons for this are not hard to find.

Between the time of development of the first generation (*circa* 1982 and 1983) and the current generation of new CD players (beginning 1985) there has been not less than one intermediate step for the small manufacturers and up to three discrete technological generations for the larger Japanese and European manufacturers. The explanation comes when you compare the first commercial Sony CD player with the latest.

The CDP101 thus incorporated 43 discrete integrated circuits (ICs), and no less than 49 transistors, and at least 69 other semiconductors. In order to achieve the essential reductions in size, complexity and thus cost, the design of the D50 is based on two primary large (LSI) integrated circuits (see accompanying photo). These have achieved a veritable 'quantum leap' in technological innovation.

But at this point I will leave the background and deal with the primary purpose of the review, which is of course the Sony D50 compact disc player.

### The Sony D50 CD

When you pick up the unit you note that it does not look like a CD player, if anything it looks more like fancy packing for some new cosmetics.

The design is based on a rear hinged moulded plastic flip up lid which is activated by a triangular push button at the right hand front top corner of the cabinet.

When this button is depressed the lid pops up 40 mm at the front. If a disc happens to be playing then this automatically switches off the unit. To gain access to the disc well you have to manually raise the front of the cover a further 150 mm. This then provides clear access to the disc well or to the disc if one is already loaded. On removing the disc, the laser assembly can be clearly seen through an elongated slot on the left hand side of the player. A small printed note exhorts the user "never touch the lens". Once loaded the CD disc is clamped between the small central turntable extension and a matching flexible rotating (slave) top clamp element, located on the top cover. It is apparent that some of the concepts developed for the small parallel tracking record player have been used to good advantage in this unit.

The cabinet width is only 7 millimetres greater than that of the CD disc, which is precisely 120 mm. This results in an extremely neat and functional module which has portability as its key feature. The minuscule front panel is divided into two sections. On the left hand side is a liquid crystal display with two associated switches. The display normally (or initially) provides data on the track number and the elapsed time in minutes and seconds for that specific track. By pressing the switch marked "REMAIN" the number of remaining tracks on the disc are displayed, as well as the residual playing time on the disc, in minutes and seconds.

The second miniature switch is marked "MODE" and two designations appear on the liquid crystal display which read "AMS" which stands for Automatic Music Search and "SEARCH". In the AMS mode the FAST FORWARD and FAST REVERSE buttons at the other side of the escutcheon advance or rewind the disc to the start of the next or last track in discrete steps. When the mode is switched to SEARCH you are able to advance or retard the playing position in rapid time so that you can find and listen to the speeded up music and cue to any portion of a track on the disc ready to play normally. As well you can then select the pause position in order to await for an appropriate moment when you may wish to start playing. These facilities of course are duplicating the conventional concepts which Sony initially provided in the CDP101 and subsequently in the latest CDP11S but with

far greater ergonomic economy.

On the right hand side of the front panel finished in bright silver are the four feather touch primary controls.

These are the epitome of sensible ergonomic design and achieve maximum flexibility and utility. The largest control is the PLAY/PAUSE control which, if touched once, will start the unit into the PLAY mode. If touched once more this sets the unit into the PAUSE mode. This is very economic on control panel space and I believe it will become the new industry ergonomic standard for all miniature and low cost compact disc players.

To the right of this control are two smaller buttons each with the appropriate double arrow symbols indicating FAST FORWARD and FAST REVERSE. Their precise functions are controlled by the MODE switch located on the left hand side of the front panel. Immediately below these two controls is an elongated STOP button designated by means of a 'square' in the middle of the switch. On the sloping bottom section of the rear panel immediately below the start button is a power ON/OFF switch, whilst below the stop button the edge of a rotary volume control protrudes. The miniature headphone socket is located immediately around the right hand corner of the cabinet close to the lower edge of the module.

On the rear panel there are only two sockets. One is a coaxial 9 volt dc input socket whilst adjacent to it is a 3.5 mm miniature diameter tip, ring and sleeve line output socket.

### On the inside

It is below the user accessible panels of the unit where the innovative electronics and most exciting features really lie. As the attached photos show, the unit consists of a

miniature motor block driving the central spindle and the associated laser optical tracking head. This is powered by a sub-miniature Hall effect drive motor and amplifier. The individual components are interconnected by means of flat flexible printed circuit cables through to the main printed circuit board of which size and brevity of components positively eclipses the technology of the first, second and even some of the third generation CD players.

The most critical element in this CD player is the flat optical pick-up which is so small and so sensitive that it is worthy of the annual Electronics Industry Award. I am reasonably sure that the D50 will deserve such an accolade when the awards are finally judged at the end of 1985. Although Sony was loath to divulge the secrets of the design, it is clear from my examination of the unit, that the miniaturised sophistication of the azimuth control and its optical depth of field are justifiably worthy of an award in their own right.

The main printed circuit board incorporates the two main large scale ICs together with a large sealed metal electronics block (in which Sony has worked integrated circuit miracles and on which subject they are unwilling to talk). The main printed circuit board has the same dimensions as the unit and lies at the very bottom of the cabinet in the only position available for it. In Japan, the shops are selling the unit with a traylike power supply designated AC-D50. There is also an external battery pack type EBP-9LC and a cord for connecting the unit to automotive cigarette lighter sockets. They have also developed a pack complete with a shoulder strap so that the unit may be used as a conventional 'Walkman' unit with external headphones or ear pieces.

In Australia the unit will be initially mar-



Sony has reduced most of the electronics in the D50 CD player to just these two ICs.

# SOUND REVIEW

keted with an Australian manufactured ac/dc 9 volt supply of the type described above which provides voltage but no buffering.

## Testing

The objective testing of the D50 presented no problems whatsoever as all the normal and important functional user controls are provided. The frequency response of the unit is exemplary being within +0, -1 dB to 19 kHz at which point it rolls over and drops by 8 dB at 20 kHz.

The expanded scale level recordings (using a 10 decibel potentiometer) reveal that there is a little more ripple than I would have expected from the normal level recording. The frequency response performance is nonetheless excellent considering the cost, size and section of the market at which the unit has been aimed.

It is the other objective tests which are usually far more telling. I compared the digital to analogue conversion linearity test

results with those measured on the CDP101 only two and a half years ago. The results were almost exactly the same down to -80 dB (that is with 0.2 dB) and were only 1.5 dB inferior at -90 dB (where you can't really hear anything anyway).

The channel separation is extremely good with the measured difference for the left channel from the right channel being well within specifications at both 100 Hz and 1 kHz; and still only 71 dB at 10 kHz.

The separation is still moderately good, but not outstanding at 20 kHz where it is 56 dB (where once again you won't hear anything). The channel separation for signals from the right channel into the left channel is not quite as good but is still impressive.

The distortion performance at the various test operating levels is basically not quite up to that produced by the CDP101. It should however be remembered that the performance of the CDP101 at the time of its release and for up to a year later was not really bet-

tered by any other player. The total performance distortion at 0 VU is 0.0048 per cent at 100 Hz, 0.0033 per cent at 1 kHz and 0.026 per cent at 6.3 kHz. The distortion level at 1 kHz with reducing level does not start to become significant until -70 dB when it climbs to 2.25 per cent after which it rises to 6.8 per cent at -80 dB and 23.4 per cent at -90 dB. The figures, it should be noted, are again close to the performance achieved by the CDP101 which was also one of the best players which we have tested in terms of measured distortion.

The emphasis characteristics of the unit are very accurate at 1 kHz, quite adequate at 5 kHz and acceptable at 16 kHz where the frequency droop in the output of the unit adds to the measured error. The D50 tracks adequately all of the fingerprints tests, the interruption tests from 400 micrometres to 900 micrometres and the black dot test from 300 micrometres to 800 micrometres. It will not track the eccentricity test record with eccentricities greater

MEASURED PERFORMANCE OF SONY MODEL NO. D50, SERIAL NO. 58110				DISTORTION (@ 100Hz)					
1.	<u>FREQUENCY RESPONSE</u> 20 Hz - 20 kHz +0,-1.5 dB			Level	2nd	3rd	4th	5th	THD%
				0	92.3	-87.7			0.0048%
				-20	-				
				-40	69.7	-68.5			0.050%
				-60	-45.3			-49.7	0.90%
2.	<u>LINEARITY @ 1kHz</u>			<u>DISTORTION (@ 6.3kHz)</u>					
	<u>NOMINAL LEVEL</u>	<u>L. OUTPUT</u>	<u>R. OUTPUT</u>	0	-83.6	-72			0.026%
	0dB	0dB	0dB						
	-1.0	-1.0	-1.0	5.	<u>EMPHASIS</u>				
	-3.0	-3.0	-3.0		<u>Frequency</u>	<u>Recorded Level</u>	<u>Output Level (L)</u>	<u>Output Level (R)</u>	
	-6.0	-6.0	-6.0		1kHz	-0.37dB	--0.4	0.4	
	-10.0	-10.0	-10.0		5kHz	-4.53dB	-5.1	-5.0	
	-20.0	-20.0	-19.9		16kHz	-9.04dB	-11.5	-11.2	
	-30.0	29.9	-29.9	6.	<u>SIGNAL TO NOISE RATIO</u>				
	-40.0	-40.0	-40.0		Without Emphasis	88.5dB(Lin) 95.2dB(A)			
	-50.0	-49.9	-49.9		With Emphasis	95.0dB(Lin) 100.3dB(A)			
	-60.0	-59.8	-59.9	7.	<u>FREQUENCY ACCURACY</u>				
	-70.0	-69.6	-69.6		+1.3 Hz for 20 kHz test signal				
	-80.0	-78.7	-79.0	8.	<u>OUTPUT IMPEDANCE (@ 1kHz)</u>				
	-90.0	-86.0	-86.6		Head phone jack	51 ohms			
					Line output	440 ohms			
3.	<u>CHANNEL SEPERATION</u>			9.	<u>DIRTY RECORD TEST AND BLACK DOT READOUT TEST SECTIONS</u>				
	<u>FREQUENCY</u>	<u>RIGHT INTO LEFT dB</u>	<u>LEFT INTO RIGHT dB</u>		INTERRUPTION IN INFORMATION LAYER PASSED ALL LEVELS				
	100Hz	-90.8	-116.4		10.	<u>VIBRATION TEST</u>			
	1kHz	-88.5	-92.7			Impulse Level Threshold	0.6"G" Horizontal 0.47"G" Vertical		
	10kHz	-71.1	-71.7			MEASURED OUTPUT CHARACTERISTICS OF HEAD PHONE JACK			
	20kHz	-54.9	-56.2			Maximum output at clipping 0.64V and 12-8mW into 32ohm load.			
4.	<u>DISTORTION (@ 1kHz)</u>							Distortion @ 10mW(1kHz) 0.1%	
	Level	2nd	3rd	4th	5th	THD%			
	0	96.3	90.0	-	107.7	0.0033			
	-1.0	96.9	89.3	-	106.1	0.0037			
	-3.0	98.3	92.1	107.3	-	0.0028			
	-6.0	-	93.7	103.6	-	0.0022			
	-10	96.1	98.7	-	-	0.0019			
	-20	-	89.3	-	-	0.0034			
	-30	-	-	-	-	0.064			
	-40	-	63.9	-	-	0.20			
	-50	-	56.0	-	58.1	0.59			
	-60	-	-47.0	-	-48.1	2.24			
	-70	-	-33.0	-	-	6.8			
	-80	-	-24.4	-33.6	-	23.4			
	-90	-	-	-20.2	15.8				

Sony D50. Audio characteristics as measured.

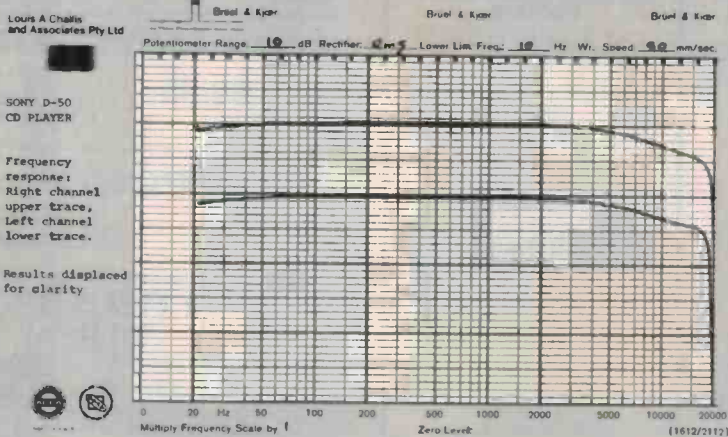
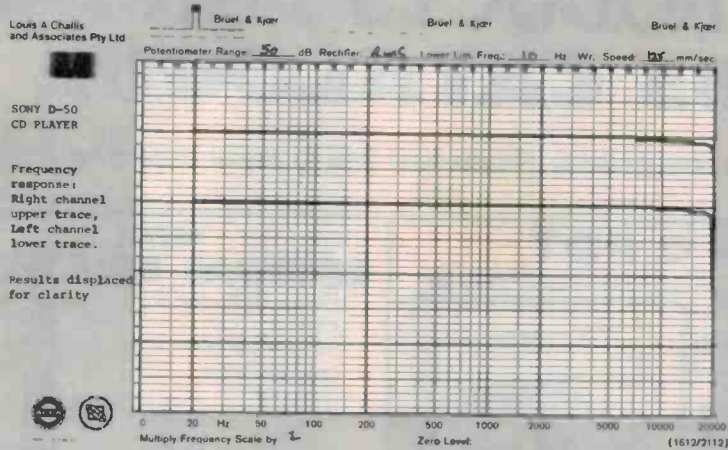

Measured squarewave response of the D50 CD player at 100 Hz and 1 kHz using bands 37 and 38 on Sony test record type 3.

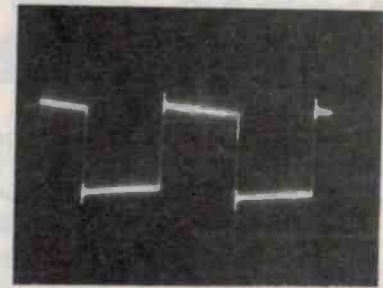

100 Hz

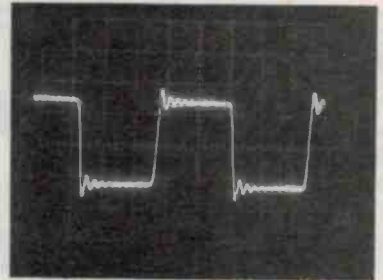

1 kHz

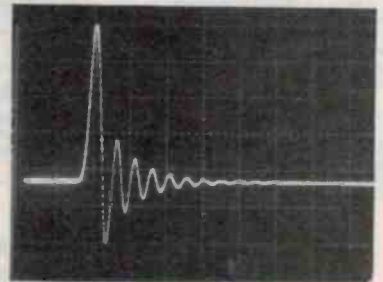

Measured impulse response of Sony D50 compact player.

than 150 micrometres or those with warp angles greater than 4°. But it should be noted that there are not many other players that currently cope with these levels of disc distortion.

The signal to noise ratio is without emphasis and is 88.5 dB unweighted and 95.2 dB(A) weighted. With emphasis these figures increase to a healthy 95 dB unweighted and 100 dB(A) weighted which is really excellent. The frequency accuracy of the unit is exceptionally good having a deviation of only +1.3 Hz for the reference 20 kHz signal.

The square wave test signals reveal the typical digital ringing at the leading edge transition for both the 1 kHz and 100 Hz signals whilst the impulse response reveals a good clean transition with precisely the same ringing characteristics generated by the digital low pass filter.

The vibration tests confirmed that the unit's immunity to steady state and shock vibration is relatively good and that the unit should be capable of performing on all, bar the roughest jogging or worst road conditions if used in a car.

Taken overall the objective test results

are both exciting, and considering the cost of the unit, considerably better than required for its 'Walkman' role. They are fully adequate for a true 'hi-fi' role when used as a primary input system for almost any type of home hi-fi system.

The subjective evaluation of this unit was absolutely delightful as I listened to many demonstration discs as well as a number of the latest and best discs produced. They included Status Quo's "Never too late" (Vertigo 800 053-2) and Josef Suk and the Smetana Quartet playing "Mozart's Quintets" (Denon 38C37 7179) which are superb classical discs. One new disc which I played was music by one of my favourite musicians Oscar Peterson and his Trio on "Tristeza" which is now available on CD utilising re-sweetened analogue recordings circa 1970 (MPS 817 489-2). This version is clearer and has more transparent musical content than the microgroove records that I have, and fully justifies the release of this new disc.

As my last series of subjective assessments I connected an external 9 volt battery

pack and with some trepidation I used the D50 in the car (when driving), carried it in my camera bag when walking and connected it up at home as part of my normal home monitoring system. The subjective differences between the performances of this unit and the more conventional and much more expensive CD players which I am currently using or have previously reviewed was quite inconsequential. More importantly the unit coped well with the motion (provided I didn't jog) and provided the road surface was reasonable.

It is discs of this quality played on machines of this calibre which within the next two years will change the very nature of the recording industry, the type of hardware that music is played on and the appearance and type of record shops and outlets with which you have been so familiar.

The signs and signals are clear that Sony has opened 'Pandora's box'. The D50 compact disc player has probably in 'one bold stroke' spelt the doom of the ubiquitous microgroove recording which we have 'used and loved' for almost 30 years.

Bravo, Sony!

# GREAT NEW PRODUCTS FOR 1985!

## JAYCAR 1985 CATALOGUE

The new 100 page Jaycar Electronics Catalogue is now available. Please send SAE to Jaycar Electronics or call into any one of our stores listed on page 25.

### SY4015 Relay 48V 6 PDT

We had these on special 12 months ago and sold thousands. Now is your chance again. They will work from about 15 volts but are reliable at coil voltages above 20.

Usually \$6.95

This month **95c 10UP 75c**

**"PHONY" PRODUCTS??** These products are more "Phonie" than "Phony." And why? Because Jaycar gives you the greatest range of Phone accessories & components at the best prices!

#### TELEPHONE PLUGS & SOCKETS

Cat. PP1400 Standard line plug only \$2.95 10 up \$2.45

Cat. PP1410 Line or Surface Mount Socket. Only \$3.95 10 up \$3.50

TELEPHONE CABLE (Solid colour coded conductors)

Cat. No. WB1602 2 pair (4 wire) Only \$0.50/Metre 100M \$0.45/M

Cat. No. WB1603 3 pair (6 wire) Only \$0.70/Metre 100M \$0.65/M

Cat. No. WB1610 10 pair (20 wire) Only \$1.50/Metre 100M \$1.20/M

All telephone cable covered in standard cream outer sheath.



#### ROTARY TELEPHONE DIALS

Brand new dials surplus to requirements from a famous local manufacturer. They are very high quality, with governor & contacts fitted. Ideal for telephone enthusiasts. 1000% of uses e.g. combination code etc.  
Cat. YTG900 \$2.95 SELLING FOR \$4.95 elsewhere.

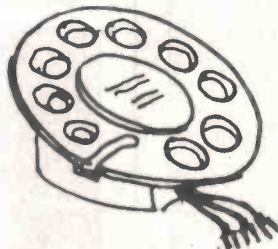

#### Built-up 'phone leads

5 & 10 metre leads are fitted with high quality stranded wire cables featuring thick sheath wall & secure termination. Will work with PABX's etc. & are suitable for heavy commercial use. The 15 & 20 metre cable is supplied on an attractive telephone-shaped wind-up reel & the double adaptor is just that - plug two 'phones into the one socket.

Cat. YT6010 5M LEAD NOW \$12.95

Cat. YT6012 10M LEAD NOW \$15.95

Save \$4.00

Cat. YT6018 15M LEAD NOW \$14.95

Save \$5.00

Cat. YT6014 20M LEAD NOW \$22.95

Cat. YT6020 Telephone Double adaptor \$12.50



**- MAKE YOUR OWN EXTENSION LEADS & SAVE!!**

#### UNIDEN 27MHz/156 MHz Marine Two-way

"Sea Wasp"

This great new marine two-way radio is fitted with all current 27MHz marine channels (inc. both distress), plus 2 vacant 27MHz channels for your own use. But the big news is that this radio will receive 2 of the OTC "Seaphone" VHF FM channels. That's right, it will receive channel

16 (Distress) & Channel 67 (weather). What a great idea!

Apart from this it is a fully approved 5 watt 27MHz transceiver with many features.



**ONLY \$199**

Cat. No DT5410



### NEW! EPROM ERASER

- Erase up to 9 chips at a time.
- Safe and convenient.
- Chip drawer has conductive foam pad.
- High UV intensity at chip surface.
- 240V powered.
- Long tube life.



**ONLY \$79.50**

### CLOCK MOVEMENT

THIS MONTH **\$9.95**

SAVE \$5.00

NORMALLY \$14.95

### COMPUBOT

**\$39.95**

SAVE \$10.00

NORMALLY \$49.95

### WATCH ROBOT?

Ideal children's toy. **\$4.95**  
Accurate quartz movement.  
Watch converts to a Robot!



### 240-9V Plug adaptors Slashed!

Genuine 'ARLEC' 9V 200mA plug packs at unbelievable prices! Our 9V 100 MA unit usually sells for \$8.95. For this month you can grab them for

**\$4.95!**

(Supplied with DC plug on the end of 1.2M lead)  
Cat. MP.3008



**SAVE \$4**

### 8 SECTOR BURGLAR ALARM KIT... NEW KIT

- REF: EA Jan 1985
- \* 2 delay sectors \* 6 instant sectors \* Steel box
  - \* Price includes battery
  - \* Siren driver \* Variable exit/entry delay \* Can use N.C. & N.O. on the one circuit!!
- Cat. KA-1580



**ONLY \$129**



# "You ain't seen nuthin' yet!!!"

## ULTRASONIC PEST REPELLER

NEW

ONLY \$69

- Which of these do you need to get rid of? - mice, blowflies, birds, spiders, bats, rats, cockroaches, flies, moths or fleas?
- The 'Vermindex' ultrasonic insect/pest repeller creates a sonic environment which is totally hostile to the creatures mentioned above.
- How does it work?
- The environment is relatively devoid of ultrasonic sounds. Evolution has not had a compelling reason to protect non acoustic sensory mechanisms from ultrasonic stimulation. By subjecting an insect or rodent to a high level ultrasonic soundwave of a particular pattern the creature begins to behave in a typical fashion. The pest becomes disoriented, lethargic and bewildered. The natural reaction is to escape from the sound-affected area.
- The sonic pattern is the secret and this pattern is a combination of scores of frequencies mixed together. The pattern was developed by Professor J.L. Stewart - the man who invented the Bionic ear. It works!
- Like us, you would be skeptical at first that this would work. Our first reaction was, "If they are so good why haven't I heard about them before?" or "Surely a product like this - if it was any good - would have been around years ago." There have been ultrasonic repellers around but none of them have the patented soundwave pattern of the Vermindex. We have on our file many, many letters of testimony to the fact that the Vermindex is effective. The letters are from Australian Universities, Animal Husbandry research Institutions, Commercial Piggeries, restaurants etc. Many of them had severe pest problems!
- Your pest problem may not be as bad but it may still be a nuisance, which is why the domestic Vermindex unit was developed.
- We are so confident of the Vermindex units' effectiveness, we make the following offer:
- Buy the Vermindex from us and use it for up to 14 days (21 days for mail order customers). If you are not happy with the product after using it as directed, return it to us in clean original condition & we will refund your money in full! (Less post/packing). What have you got to lose?
- The Vermindex covers an area of 2000 sq. ft. (uninterrupted) and is not cheap. But if the idea of dangerous chemicals, sprays, baits etc. worries you its a great solution. It is supplied with a 240V plug pack but can be battery powered.
- What have you got to lose except the bugs? Cat. No. YS5500



NEW

### High Quality Japanese-made Heavy-Duty cordless 'phones!

Once again we were not happy with the cheaper units on the market. Several low-cost models were evaluated which we found to be unreliable in service (e.g. many would not penetrate from the front of a brick house to the back of the backyard. Some had very short NiCad battery life. Many were not approved). The Telecom and Dept. of Communications Approved devices are JAPANESE-MADE Quality. Two models are stocked: The CT-600A (Cat. No. YT7050) is designed for domestic applications. The unit features good range, good tonal quality & paging facility.

Cat. No. YT7050  
Model CT600A  
ONLY  
**\$229**

Cat. No. YT7060  
Model CT505A  
ONLY  
**\$399**

The CT.505A is a deluxe heavy duty unit which features a twin battery pack system. This enables you to continue operation in high-usage circumstances. Simply exchange the discharged battery pack with a freshly charged unit which comes from the base unit. The CT-505A provides the maximum range available in compliance with Australia's legal requirements. It also has unique security coding which prevents unauthorised use of your telephone.



### Kids Bike "Emergency" Siren - Great New Toy -

CB-type microphone with siren/speaker/horn 4-way switch on mic. gives you: Police, Fire & Ambulance Sirens (all distinctive) PLUS Public Address! (It doesn't make enough noise to be a nuisance but is great fun!)

Cat. AS3190 **only \$8.95**



### Blotron "Electronic Blood/Alcohol Checker.

Simply blow into the mouthpiece to see if you are over the limit. Dual analogue meter & led go/borderline/no go readout. Calibrated in Australia. Surprisingly accurate. Can be recalibrated if laws change. Specify 0.05 or 0.08.

Cat. YS5100 **only \$75** save \$3.



### "Cube" Clock Radio

At last, a good old analogue display that is accurate, easy to read & easy to set (both time & alarm). 115 mm square front (clock face 95 dia.). Battery powered & therefore safe for kitchen or bathroom.

Cat. AR0952 **only \$19.95**

## PASSIVE INFRARED DETECTOR

Jaycar breaks the \$100 price barrier. Bulk buying by Jaycar has enabled us to pass on large savings on popular Passive Infra-Red detectors. PIRs (as they are known in the trade) are the most popular method of detecting movement in open areas. They are very reliable and being passive (i.e. they are not transmitters like microwave or ultrasonic sensors) they false trigger a lot less. For a technical description see page 21 of our 1984 Catalogue. The only drawback in the past was their fairly high cost. Now you have no excuse to install one (or two) as part of your alarm system. (Please note that the illustration is indicative of PIR. We reserve the right to ship units of similar performance but possibly different physical appearance).  
Cat. LA-5015

ONLY \$99

### Quality VHF Video/Audio RF Modulator

At long last a good quality, stable video/audio-to-RF modulator. It even will enable you to connect a Commodore VIC-20 to a VHF T.V.! Note that this module is specially tuned for Australian T.V. (VHF CHAN 0 & 1 5.5 MHz Sound Subcarrier). A full data sheet & connection diagram is included!

Cat. LT3802 **\$9.95 ONLY!**

AT NEW!  
AT LAST!

### BARGAIN! JEWELLER'S 6-PIECE SCREWDRIVER SET

In Vinyl wallet. Normally \$3.95  
**FEB ONLY \$1.98** 1/2 PRICE! Cat. TH2005



# Jaycar ELECTRONICS

Incorporating ELECTRONIC AGENCIES  
**NUMBER 1 FOR KITS**

**N.S.W.**  
SYDNEY: 117 York Street Tel (02) 267 1614  
CARLINGFORD: Cnr. Carlingford & Pennant Hills Road. Tel (02) 872 4444  
CONCORD: 115/117 Parramatta Road. Tel (02) 745 3077  
HURSTVILLE: 121 Forest Road Tel (02) 570 7000  
BURANDA: 144 Logan Road Tel (07) 393 0777  
Mon - Fri 9am - 5:30pm, Thurs 8:30pm, Sat 12pm  
Thursday nights: 8:30pm

**MAIL ORDERS:** P.O. Box 480, AUBURN 2144. Tel: (02) 643 2000  
**HEAD OFFICE:** 7/9 Rawson Street, AUBURN 2144.  
Tel: (02) 643 2000 Telex: 72293

**SHOP HOURS**

Carlingford, Hurstville	\$5 - \$9.99	\$1.50
Mon-Fri 9am - 5:30pm, Thurs 8:30pm, Sat 12pm	\$10 - \$24.99	\$3.20
Sydney	\$25 - \$49.99	\$4.50
Mon-Fri 8:30am - 5:30pm, Thurs 8:30pm, Sat 12pm	\$50 - \$99.99	\$6.50
Concord	\$100 - \$198	\$8.00
Mon-Fri 9am - 5:30pm, Sat 12pm	Over \$199	\$10.00

**POST & PACKING**

COMET ROAD FREIGHT ANYWHERE IN AUSTRALIA ONLY \$12

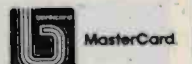

**MAIL ORDER VIA YOUR PHONE**

# THE PENCIL IRON WITH REAL POWER - MiniScope

10W - 70W  
POWER UNDER  
YOUR CONTROL



All the advantages of a miniature soldering station - without the power restrictions.

Ideal for precision circuitry when operating in the 10W-20W range or for the heavier job.

You can call up \*real power - up to 70W in just a few seconds.

- Comfortable shape
- Light weight
- Isolated from mains
- Fast 5-second head
- Manual temperature control
- Safe 4 volts
- Automatic switch off
- Owner maintenance simple & quick

#### NSW

Pauls Merchants (02) 709 2311  
Dick Smith Stores  
BBC Hardware (most stores)  
David Reid (02) 267 1385  
Sheridan Electronics (02) 699 6912  
AVTEK Electronics (02) 267 8777  
John R. Turk All Branches  
J. Blackwoods (02) 609 0030

#### VICTORIA

Radio Parts (03) 329 7888  
Magraths (03) 347 1122  
Dick Smith Stores  
Ellitronics (03) 602 3499  
Geo. Brown (03) 419 3355  
W.A.  
Atkins Carlyle (09) 277 0511  
Dick Smith Stores  
Rod Irving Electronics (03) 489 8866

#### QLD

Dunlop IBC (07) 392 0011  
Repco (07) 221 1044  
Dick Smith Stores  
Elphinstones (07) 52 0171  
St. Lucia (07) 52 7466  
TAS  
GHE Electronics (002) 34 2233  
Dick Smith Stores (003) 31 6533

#### S.A.

Gerard & Goodman (08) 223 2222  
Protronics (08) 212 3111  
Bee Jay (08) 352 5959  
Dick Smith Stores  
Graphic Electronics (08) 42 6655  
A.J.F. Electrical (08) 269 1244



**SCOPE**  
BOX 63 MIDDIE  
VIC 3042  
TEL (03) 338 1566  
TLX AA38318

## Amplifiers

**TD300** \$510.00  
Slave Amp (150 watts per channel into 16 ohms) with stereo to mono switching.  
**ZPE SERIES II** \$1300.00  
500 Mosfet Output Stages 250W into 8 ohms

## Disco Mixers

**CITRONIC SM 330** \$695.00  
6 Channel Input (2 Mikes + 4 aux)  
**ARISTA** \$330.00  
6 Channel Input with Equalization.

## Lamps

**DX60-ES, 240v, 60w** \$3.00  
Discolux (soft glass) E.S., assorted Colours Box of 25 - \$65.90  
**G40BC, 240v, 40w** \$0.88  
BC Lamps in Blue, Yellow, Orange, Red, Green, Box of 100 - \$70.50

## Turntable

**CDC 8003** \$225.00  
Direct Drive with Pitch Control  
**TECHNIC SL1200**  
Top of the range \$550.00

## Jumbo Strobe

**FLA 701** \$153.48  
White Flash Jumbo Strobe with Speed Control.

## Helicopter

A GE 4515 lamp in housing can be swivelled and directed up or down spinning 360° in the one place.

**RPS 102** 2 ARM SPINNER \$198.00  
**RPS 104** 4 ARM SPINNER \$289.00  
**RPS 106** 6 ARM SPINNER \$392.47  
**RPS 108** 8 ARM SPINNER \$497.89  
**UFO 324** UFO LIGHT (24XGE 4515) \$1698.55

**G25BC, 240v, 25w** \$0.78  
Box of 100 - \$62.50

**FLOURESCENT TUBES**  
White \$2.30  
Colours \$6.50  
Ultra Violet \$25.00  
4 ft.

## Scanner

**S101** \$99.45  
Search Lighting effect

## Scanner Bar

**S104S** \$342.86  
Light bar housing four GE 4515 lamps scanning with individual motors.

All housing complete with front cover and with provision for colour gel.

## Micro phones

**129B** 12" Flexible Chrome Arm, goose-neck \$21.55

**186C** Chrome Base Mount \$19.74

**518C** Soundmaster Mikes \$89.75

**UD312** Primo Mike \$96.95

**102** Mike Stand, Adjustable \$93.80

**HL43U** Flexible Arm Mike Holder - \$6.99

## SMOKE MACHINE

(Great for Special Effects!) \$328.00  
Fluid - 1 litre \$15.00

## Pinspot

**PS 112S** (Par 36 can) \$48.94 (6v, 30w) Designed specifically for Mirror Ball Spotting. Used widely to achieve a bullet beam effect.

**BONUS OFFER:**  
Buy 10, Get One FREE!

**PS 112L** (Par 46 can) \$58.99  
**PINCHASER S480** Exclusively for Pinspots.

## Halogen Beacons

**WL 104** - \$132.59  
Warning lights are available in different colours.

## ARTLITE

20th Century plastic in flat sheets (2 mm or 100 mm) or round tubing (8 mm) that glows under ultra violet lighting.

Available in 5 different colours.  
Ideal for disco installations and signwriters.

From 50 cents per metre!!!

## Rope Lights

FOR BANDS DISCOS & CLUBS

**PRL 803**  
Rope light, Tubes Red, Blue, Green, Orange, White.

\$109.77 each colour

**MULTI COLOURED:**

White reinforced spiral tube with MC lamps; tread-proof.

**SRL 801** - \$115.88  
Rope Controller \$155.00

## Border Lights

**BL104** - \$163.70  
FREE Gel Filter Frame Mount Rkts.

## Mirror Balls

**MB 005, 5"** \$13.82  
**MB 008, 8"** \$37.20  
**MB 012, 12"** \$64.58

**MB 014, 14"** \$93.54

**MB 018, 18"** \$125.34

**MB 020, 20"** \$153.79

**MB 012C** Mirror Cylinder (12" length) 6" Dia. - \$43.18

**MB 008H** Half Mirror Ball & Motor, 8" - \$54.11  
**MB 012H** Half Ball & Motor, 12" - \$76.11

**MIRROR BALL MOTORS:**  
D.C. 1.5v Motor - \$9.95  
A.C. 240v - \$29.99

Disco World Pty. Ltd.

**SHOWROOM:**  
300 Main Street, Lilydale, Melbourne Vic 3140.

Postal Address:  
P.O. Box 509, Lilydale, Melbourne Victoria 3140  
Telephone: (03) 735 0588

## Cosmos Light

Mirror Ball housing 24 x GE 4515 lamps with provision for colour gel spinning in two planes, (vertical and horizontal)

**CLG 324** - \$1980.68

**DOUBLE COSMOS:**  
Two Mirror Balls in each housing, 12 x GE 4515 lamps.

**DCL 212** \$2452.37

**HALF BALL ROTARY LIGHT:**  
14" Dia. housing 6 x GE 4515 lamps. Provision for Colour gel.

**HLG 06** \$357.28

## Rolling Light

Metal framed housing rotating 360° in two planes, all with provision for colour gel.

**RL 108, 8 x GE 4515 lamps** \$958.95

**RL 124, 24 x GE 4515 lamps (Horizontal)** \$1985.45

**RL 224 24 x GE 4515 lamps (Vertical)** \$1985.45

## CONTROLLERS

**AUDIO/CHASER (DW 4LC 4000)** \$295.00  
Pre-set Programmed Controller 4 Channels each 1000W.

**LIGHT COMPUTER (DW 7LC 4200)** \$488.00  
Programmable 7 channel with E-prom (16 programmes). Ideal for Advertising signs and Disco lighting.

**VU LIGHT BAR (DW 12 LC 480)** \$394.00  
12 channel L.E.D. like display controller. Triggered by sound signals. Exciting new product!

**CHASER (DW LC 4000)** \$155.00  
4 channel each 1000W with speed & mode switching.

**MUSICAL (DW M 4000)** \$130.00  
4 channel each 1000W sound to light.

PLEASE NOTE: ALL CONTROLLERS COME WITH 6 MONTHS WARRANTY.

## Special Disco Package

1 X SM 330 CITRONIC MIXER  
2 X CDC8003 TURNTABLES  
1 X 518C SOUNDMASTER MIKE  
ONLY \$1055.00

PLEASE NOTE: Some installation items do not include power cords.

ALL PRICES ARE INCLUSIVE OF SALES TAX. ASK ABOUT OUR SPECIAL RATES FOR INSTALLERS

### MAIL ORDERS:

ADD PACKING & POSTAGE (P&P) PAYMENT WITH ORDERS:

\$5.00 . \$0 - \$ 49.99    \$10.00 . \$150 - \$250.00  
\$6.00 . \$50 - \$ 99.99    \$17.00 . \$251 and more  
\$8.00 . \$100 - \$149.99    • Over \$250 add 5% per value or order.

### DELIVERY INSTRUCTIONS:

• STANDARD MAIL AS PER P & P.  
• REGISTERED MAIL - EXTRA \$4.00.  
• ROAD FREIGHT - AS PER COMET CHARGES.  
• FREIGHT INSURANCE - Extra \$1 Per \$100 Value.

BE ADDED TO OUR MAILING LIST FOR FUTURE SPECIALS TOO HOT TO PRINT HERE BY SENDING S.A.E. TO US.

# PRINTER GP-80

C-9080

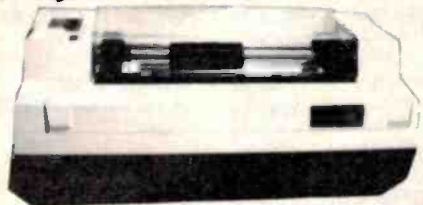

**WHILE STOCKS LAST**  
**ONLY \$199**

Save a fortune on these printers - Centronics parallel data interface - dot matrix - 204mm fan fold paper.

## Telephone Extension Leads

T-5010

Quality 6 conductor

**NOW ONLY \$12.95**

## Telephone Double Adaptor

T-5050

**NOW ONLY \$10.50**



## PHONE REEL

20 metres of telephone extension lead on hand wind up reel.

ORIGINALLY \$24.95

**\$15.95**

**WHILE STOCKS LAST**



T-5025



## DOOR INTERPHONE WITH ELECTRIC LOCK ELECTRONIC PROTECTION

This kit comprises an outside weather proof intercom unit with call button - an inside telephone handset with door release push button - a heavy duty remotely operated electric door lock - power supply, interconnecting cables and instructions.



**NOW ONLY \$99**

F-9700

**BUY NOW AND SAVE OVER \$80**

### SATELLITE TV GROUND STATION

You can now install your own 4GHz Satellite TV Ground Station for \$3,990 complete. The purchase price includes a 3.5 metre demountable mesh antenna, a 40dB low noise amplifier, a baby Q satellite receiver, a down converter, full instructions and alignment procedures. 12 months guarantee. For information phone ZAP on (02) 858 2288. Cat. X-1000

## AD-ZAPPER

No more ads in your video recordings!



B-4500

**\$149**

Connect to your VCR to automatically edit out advertisements when recording. The Ad-Zapper detects an ad break and through the pause control - stops recording. Playback recording without advertisements.



ZAP'S PRICE

**ONLY \$89**

**DIRECT IMPORT Portable Stereo Cassette in red or white SAVE OVER \$20**

A-2100

**YOUR ELECTRONICS STORE**

# ZAP ELECTRONICS 6 SYDNEY STORES

BURWOOD 51 Birwood Road Ph: 745 3188

CHATSWOOD Shop 3/16 Anderson Street Ph: 411 7366

HORNSBY Shop Mt Northgate Shopping Centre Ph: 476 6122

LIVERPOOL 270 George Street Ph: 602 0777

PARRAMATTA 60 George Street Ph: 635 5877

CREDIT CARD PHONE ORDERS 858 2288

EASTWOOD (Office & Warehouse) 10A First Avenue Ph: 858 2288



SEND FOR FREE CATALOGUE - TRADE ENQUIRES WELCOME

# Printed circuit CAD for IBM PC

**TECHNICAL IMPORTS** is marketing 'Smartwork', a specialised CAD software package to automate the drafting process in creating printed circuit board layouts.

Both the expert and novice can use Smartwork to create and revise pc board artwork on an IBM PC without tedium. Productivity is enhanced with common symbols such as Pads, Cells, DIP, SIP, normal and fat traces,

editing to move any portion of a layout and insert modifications, and full interactive auto-routing.

Using the keyboard, you can place and remove conductor pads and traces. All traces are perfectly vertical, horizontal, or

run at 45 degrees. Smartwork ensures that conductor spacing is adequate and line widths do not become too narrow for reproduction.

Drawing output can be in three forms. The first is a one to one size plot on a dot matrix printer using single pass to produce a quick check plot for component layout. The second is a double size plot on the printer using triple pass to produce prototype quality. The third is a double size plot on a pen plotter

to give a production quality layout for photo reduction.

System hardware requirements to run Smartwork are, an IBM PC or XT or compatible, with 256K memory, DOS 2.0, IBM colour graphics board and monitor, Epsom FX/MX/RX 100 or compatible, a Houston or HP pen plotter or compatible. A Microsoft or Mouse Systems Mouse is optional. Price is \$1250. For further information call **Technical Imports Australia** on (02) 922-6833.

## Spectrum analysis from dc to 100 kHz

**SPECTRUM ANALYSIS**, network testing, modelling and analysis, as well as waveform recording, can be conducted from dc to 100 kHz with just one instrument: the new HP 3562A dynamic signal analyser from Hewlett Packard.

For network analysis high-Q

devices can be measured with 1 Hz resolution in one second. Two input channels and a built-in source fulfil the basic requirements for frequency response measurements. Frequency resolution is 801 lines, dynamic range is 80 dB and channel match is +0.1 dB and +0.5

degrees.

The techniques available for measurements with this analyser are linear-resolution FFT, logarithmic resolution or true swept sine-wave.

Block-operation waveform math can be used to normalize network measurements or to compute secondary functions such as coherent output power. Independent X and Y markers speed and simplify analysis of network parameters such as filter bandwidth and slope.

HP 3562A speed and accuracy make possible on-line analysis of distortion, drift, modulation and phase noise. FFT measurement

speed lets the user see transient events that a swept analyser would probably miss.

With the fast-setup zoom and flexible markers the user can observe time and frequency traces simultaneously, display a 100 kHz spectrum on one trace and a zoom spectrum on the other, and read signal levels to 0.01 dB using markers. Demodulation allows the user to separate and analyse modulated signals in either time or frequency domain with AM, PM or FM.

For further information contact **Hewlett Packard Ltd, 31-41 Joseph St, Blackburn, Vic 3130. (03)895-2895.**



## NEW EQUIPMENT

### Universal calibrator now simulates RTD values

TUBEMAKERS PROCESS CONTROLS (TMPC) has announced the release of OhmERO, a new RTD simulator to be combined with its Memocal 81B.

The OhmERO is a plug in accessory for the Memocal 81B calibrator allowing real time simulation of resistance bulb sensors with digital readout directly in °C or °F thereby eliminating the need for cumbersome boxes and look up tables.

Units are normally supplied to DIN 43760 over the range -200°C to 850°C.

The OhmERO facility expands the universal capability of the Memocal 81B to generate as well as measure resistance together with mV, mA and 14 thermocouple curves.

For further information contact Mr Clinton Burleigh, Tubemakers Process Controls (TMPC), PO Box 381, Granville, NSW 2141. (02)682-0666.



### Digital micro-ohm meter

MODERN ELECTRONIC equipment exhibits a continual improvement in quality and specification while becoming less costly.

Hales & Rogers, a small Sydney based design and manufacturing company have made a contribution in this area as well. With the release of their Model DM-2 digital micro-ohm meter, Hales & Rogers have shown it is possible to produce a low volume, specialist instrument with

specifications previously only achieved by equipment costing far more. The DM-2 can resolve 0.1 micro-ohms, that's resolving 100 nano volts, with high stability and 0.25% accuracy.

Hales & Rogers are keen to promote the instrument Australia wide and are seeking interstate dealers. Enquiries should be directed to Bruce Rogers at Hales & Rogers Pty Ltd, 17 Mobbs Lane, Carlingford, NSW 2118. (02)85-7540.



### Telephone Analyser

A TELEPHONE analyser which can also perform a multitude of electronic measuring and testing functions, has been launched in Australia by Communication Control.

Designated the ETA 711, the unit can rapidly measure the electrical parameters of both telephones and telephone lines to detect bugs and taps. It can also perform test functions such as voltage, monitor, tone sweep, resistance, capacitance, impedance, current, wire combina-

tion, and radio frequency sweeps up to 750 MHz.

Typical applications include field engineering and servicing of minicomputer terminals, microprocessor-controlled products, CCTV systems, cable TV networks, as well as studio and mobile broadcast and recording equipment.

For further information contact, Communication Concol, Level 1, 11-13 Hartill-Law Avenue, Bardwell Park, NSW 2207. (02)923-2155. ▶

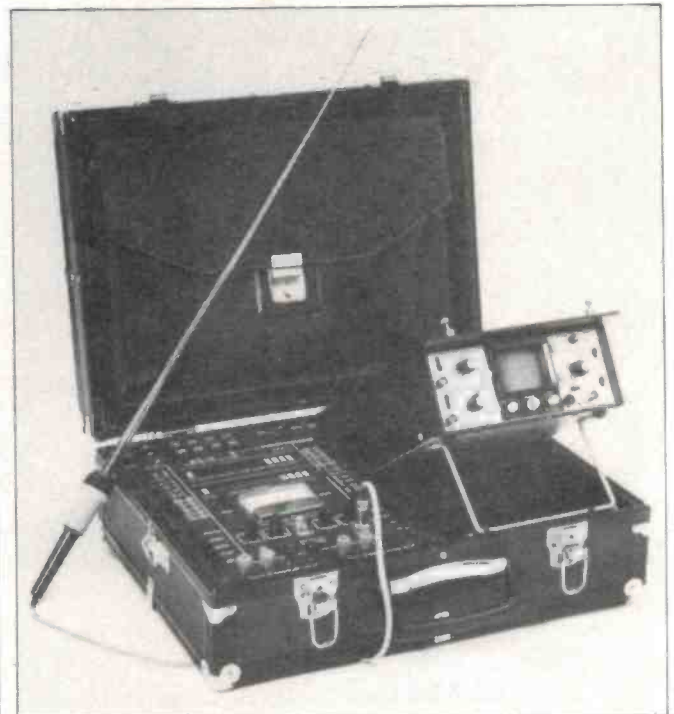

### New light dimmer

LSC ELECTRONICS, the Melbourne based manufacturer of Stage and Auditorium Lighting Control Systems is proud to announce the release of a new compact self-contained dimmer.

To be known as the Quadpak series it is to be available in two

versions: the Quadpak 2 and the Quadpak 5.

The recommended list price for the Quadpak 2 is \$670 and for the Quadpak 5 is \$740.

For more information please contact LSC Electronics, 728 Heidelberg Road, Alphington Vic 3078. (03)49-2980.

# at the leading edge

## **NetSource PC LAN LINKS UP TO 254 WORKSTATIONS**

The **WD4028**, user installed, **Token Access Controller** from **Western Digital** offers high, contention-free, **network** performance. Station dropouts are automatically compensated for by hardware. **MS-DOS** compatible software is supplied with the board and virtually any multi-tasking operating system can be supported.

## **OptoMos PRICE PLUNGE COULD JOLT DIP REED MARKET**

With quantity prices dropping from \$9.00 to around \$4.00 **Theta-Js\*** **optically coupled VMOS** will find more applications in telephone and instrumentation related fields. The **six pin DIP** LCA-110 can handle both **AC** and **DC** voltages from microvolts to **300 V** peak and currents from microamps up to **100 mA**.

## **VOICE BAND SCRAMBLER CHIP BEATS SNOOPERS**

**CML** are hailing their **FX3X6** as the answer to the problem of privacy on shared or accessible voice links such as cellular radio or telephone networks. It uses a **rolling digital code** controlling a **variable band split frequency inversion** technique. This allows for **real-time scrambling** without the delay problems associated with traditional A to D, D to A methods.

## **DATA SECURITY BOARD SLOTS INTO IBM's PC, XT & AT**

Encryption and decryption of files, transparent to application software, is achieved by **Western Digital's\* WD2200**. A user customisation utility supports most PC configurations running **MS-DOS**. The **NBS Data Encryption Algorithm** based product secures disk, modem or LAN communications and system integrity can be maintained by a **user programmable key**.

### **daneva australia pty ltd**

64-66 Bay Road Sandringham Victoria 3191  
Australia PO Box 114 Sandringham 3191  
Telephone (03) 598 5622 Telex AA34439

Sydney: E&M Electronics (02) 51 5880  
Adelaide: DC Electronics (08) 223 6946  
Brisbane: Baltec (07) 369 5900

\* Registered T.M. International Business Machines Corp.



# IN-CIRCUIT EMULATION

In the last few years the technique of emulation has become very widely used in the development and testing of digital systems. This article looks at the principle of emulation, using currently available commercial units to illustrate the concepts.

THE TECHNIQUE of in-circuit emulation (ICE) provides the engineer with a simple, yet effective means of testing hardware and evaluating software in a microcomputer system. Figure 1 illustrates the principle.

The microprocessor is removed from the unit under test (target) and connection made to a second computer system (host) through a dual-in-line plug and ribbon cable. Normally the host computer uses a similar microprocessor to that removed from the target, to imitate or emulate the original processor. At first glance it might seem pointless to remove the original to have it replaced by another in the host, but the technique allows the host to get

between the target system and its microprocessor, enabling it to monitor bus activity or to inject signals into the target system.

The technique was first introduced by Intel on their microprocessor development system (MDS) to help debug hardware and software problems encountered during the development phase of a project.

Early development systems were essentially software orientated, providing editors, assemblers, linkers, and, to a limited extent, some facility to execute and debug the final machine code. However, to test hardware and software effectively it was necessary to commit the final code to EPROM before transferring it to the unit

under development. Any further debugging that was required was now carried out using a logic analyser. If faults were discovered the engineer returned to the development system to update the software before programming a new EPROM.

The introduction of ICE shortened this time-consuming procedure, allowing the design engineer to run the system under development directly from the MDS, thus eliminating the need to use EPROMs as a means of transporting software into the target system. Further, since the emulator has access to the target system's buses during program execution, it can also be used as a debugging tool. To help with this task most emulators also provide on-board logic analyser functions.

In-circuit emulation is now a standard feature on development systems with some manufacturers, including Hewlett Packard, Genrad and Tektronix, providing a range of emulators covering a variety of 8-bit and 16-bit microprocessors. However, all of these systems are well outside the budget of most individuals or small companies involved in microprocessor system development. To fill this need several manufacturers, notably Microtek are producing a range of low cost stand-alone emulators that can be driven through an RS232 interface from either a VDU or any popular microcomputer with a serial port.

The value of in-circuit emulation has also been acknowledged by those involved in microcomputer servicing, offering a simple method of injecting test or stimulus programs into a defective board. This can prove an essential facility if the unit under test does not respond to normal keyboard operation or, perhaps, as in the case of some controllers, does not contain a key-

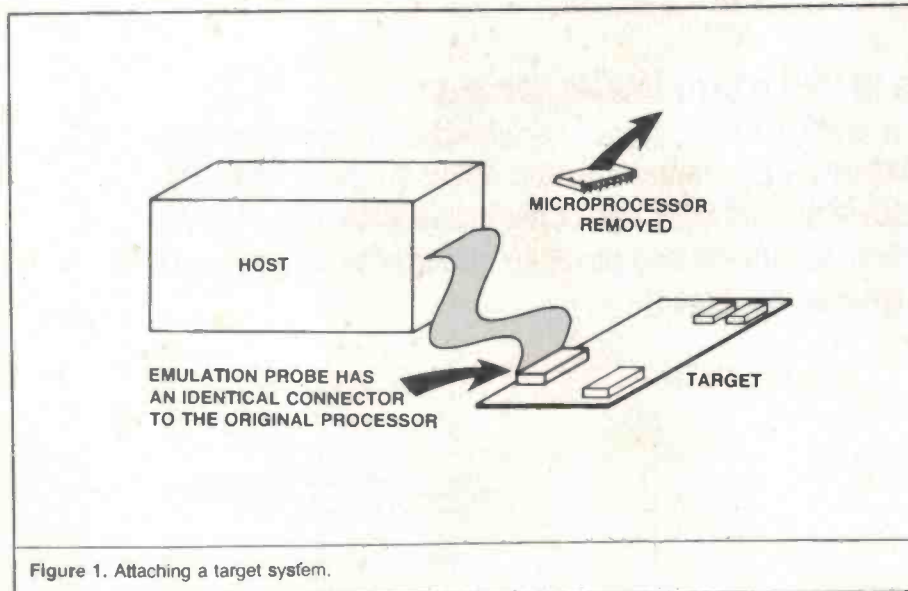

Figure 1. Attaching a target system.



## John D. Ferguson

Department of Computer Science,  
University of Strathclyde, Scotland

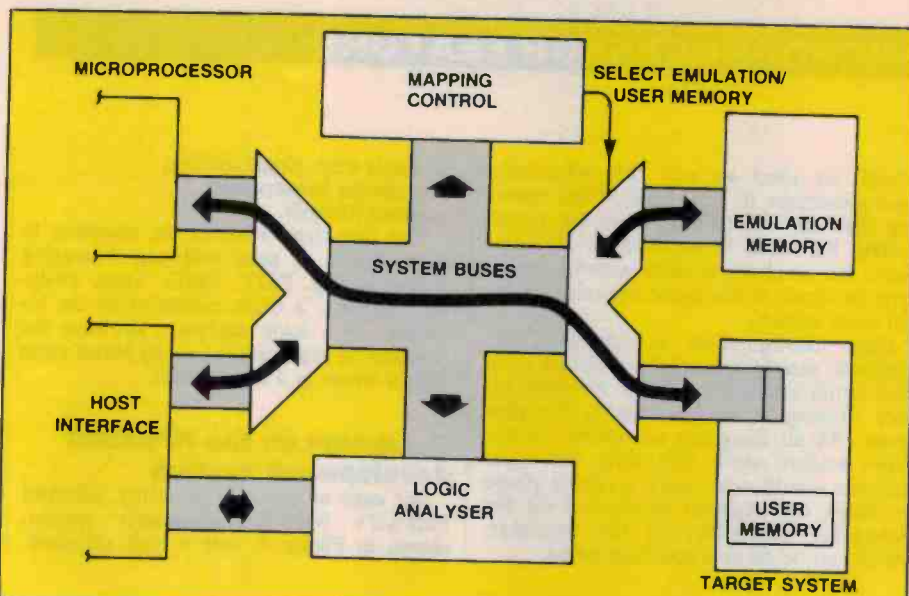

Figure 2. Simplified emulator architecture.

board. Many manufacturers, including Hewlett Packard, the John Fluke Co with their 9010 Troubleshooter and Solartron with their range of Micropods, are now producing test instruments in which emulation is an essential ingredient.

### Basic principles

Figure 2 shows a simplified diagram of an emulator's internal architecture. Control circuitry is used to allow either the host computer or the emulation processor to gain access to the target system's buses.

Most emulators are equipped with random-access memory (emulation memory) that can be used to add to, or take the place of memory on the target board (user memory). This extra RAM can often prove useful during program development, providing workspace for software before it is finally committed to ROM.

The procedure of establishing a memory layout for the combination of emulator and target is called mapping. In microprocessor development systems this is normally accomplished from the keyboard during a configuration phase prior to emulation. Simpler systems (e.g. Microtek's MICE) use small in-line switches on the emulator's main printed circuit board.

An example of mapping is shown in Figure 3. In this arrangement the memory space occupied by user ROM has been overwritten with emulation memory allowing the engineer to load and test different versions of software. After mapping has been decided, control circuitry ensures that all addresses established by the processor or host system are directed to the selected memory devices — emulation or user memory.

Normally the target system's own clock

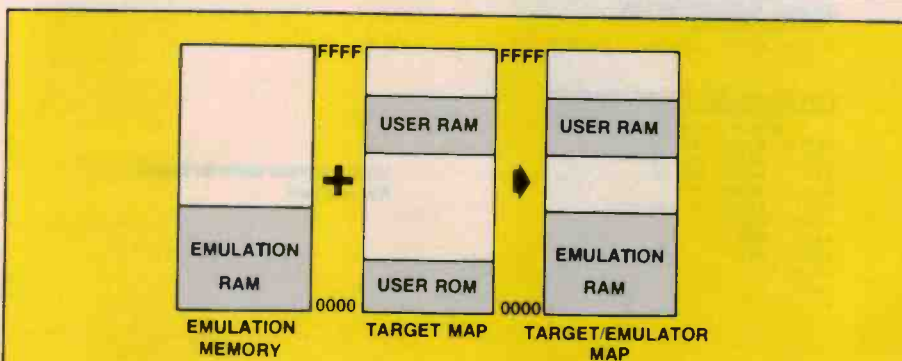

Figure 3. Mapping — constructing memory map for emulation. In this example, 'user ROM' overwritten by emulation RAM, allowing software to be loaded and tested by host system.



Figure 4. HP64000 development system — an example of universal system supporting a range of microprocessor families.

# MICROPROCESSOR FEATURE

would be used to run the emulator's microprocessor in 'real-time', thus ensuring that any critical timing of the target system hardware is maintained. If, however, the emulator is used without prototype hardware it can make use of an internal clock option.

Once configuration is complete the operator can then load the machine code into either emulation or user memory before running or simple-stepping the program. As all designers are aware, prototypes seldom work first time and most projects would now enter a testing phase in which the engineer would call on the debugging capabilities of the emulator, which can be divided into four areas:

- single step, single cycling;
- software breakpoints;
- trace analysis.

The first three features are common to those found in most software debugging packages, e.g. DDT, ZSID. Trace analysis, however, is often enhanced by the inclusion of a logic analyser, allowing the operator to capture bus activity about some trigger event in a trace buffer.

## Emulation on the HP64000 development system

For ease of use and versatility, Hewlett Packard's 64000 development system, shown in Figure 4, sets a high standard.

The system offers a variety of options ranging from a stand-alone portable station, for use in the field, to a multi-user, hard-disc based network capable of supporting a wide spectrum of microprocessor families. Multi-user capability greatly eases the problem of integrating software produced by a team of engineers, allowing different areas of a project to be developed independently and yet allowing them to be easily shared between members of the team.

Hardware options available for the 64000 include:

- a wide range of 8- and 16-bit emulators,
- a user-configurable emulator (a novel idea allowing customers to 'build' an emulator for any processor not supported by HP);
- state and timing analysis;
- a range of EPROM programmers.

In common with other systems the operator is provided with a wide range of debugging features for use under emulation. Symbolic debugging, where the operator can refer to program locations using labels defined in the source code, greatly eases use, especially when tracing routines generated by compiling high level language programs written in PASCAL or 'C'.

Depending on your needs (and assets) such a system offers many analysis options starting with a software logic analyser (not real-time) and progressing to plug-in cards that perform state and timing analysis on the emulation subsystem. Fault location with a logic analyser demands flexibility when defining the trigger event, or more completely the 'trace specification'. Figure 5 shows a variety of possible trace specifications highlighting the power of the analyser.

The systems have been on the market now for several years and most of the bugs have been removed. However, a few rough edges still remain, and some typical examples again from the HP 64000 include arithmetic problems evaluating relative jumps when disassembling Z80 code and a rather messy approach to emulating the 8088/8086, where an emulation monitor program has to be linked to and loaded with the user program.

Of the other development systems two families can be identified:

**Manufacturer specific.** This includes the INTEL MDS and the Motorola EXOR-macs development system. Each system will normally deal with all the manufacturer's microprocessors often including devices not yet covered by the 'Universal' systems.

**'Universal'.** Examples include the Future-data and Philips systems as well as the HP64000 detailed above. While covering a wider range of processors from different manufacturers, they are less likely to cope with the latest and fastest from any given supplier.

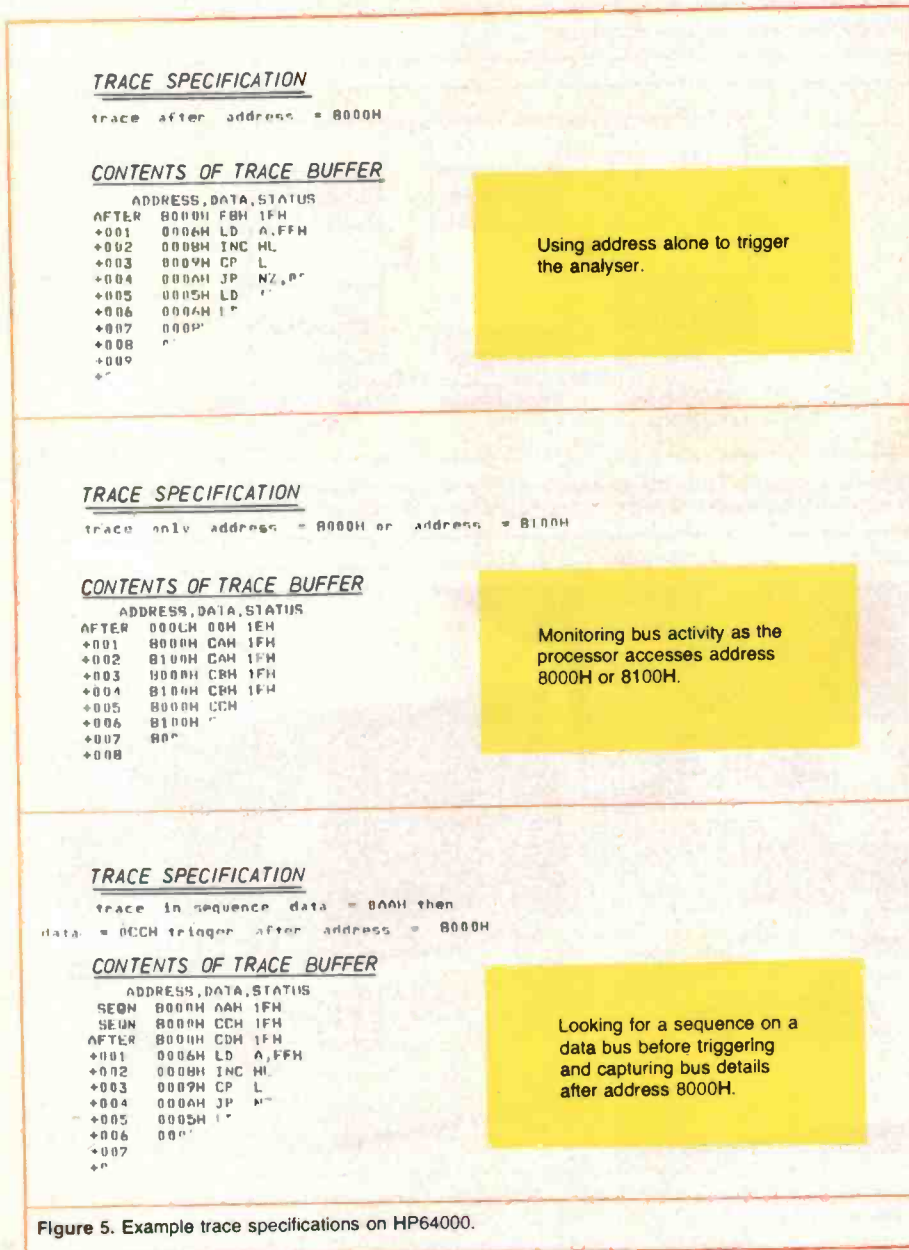

Figure 5. Example trace specifications on HP64000.

## Low-cost solution — Microtek MICE

Microtek's 'Micro-In-Circuit-Emulator' (MICE) shown in Figure 6 performs many of the functions found on a development system at a fraction of the cost. A range of personality cards allow MICE to emulate most industry standard microprocessors, including the 8088/8086, 68000, 7085, 6809 and the popular domestic processor, the 6502. Two models are available, differing in the size of the emulation RAM and the trace facilities:

**MICE I**, with 8K bytes emulation memory — not real-time trace.

**MICE II**, with 32K bytes emulation memory, expandable in blocks of 32K bytes — real-time trace.

Both models are controlled via an RS232 interface, using either a display terminal or a computer system with a compatible port.

Driving a stand-alone emulator from a VDU would only be satisfactory for a small development application or when used in a servicing role (e.g. to check RAM or form signatures of ROM using its on-board test routines). The list of commands, (see Figure 7) includes a line assembler, useful for small routines or when patching a larger piece of software and a two-pass disassembler that generates labels for all subroutine and jump instructions — a nice touch not found even in expensive systems, (see Figure 8).

Serious applications, however, would utilise a host computer system allowing code generated by assemblers or compilers to be downloaded, in either Intel or Tektronix format, to the target system. When a host system is used it requires a driver program to communicate with the emulator.

A range of routines is available for some popular systems:

- Apple;
- any CP/M machine;
- Digital Equipment minicomputers;
- Sharp Personal Computer.

Guidelines included in the manual should allow anyone with a reasonable skill in interface programming to generate a driver routine for their machine.

Trace facilities are good, allowing the operator to perform a real-time forward or backward trace capturing address, data and processor status information in a massive 2048 word buffer. However, there are limitations on the sophistication of the trigger event which is limited primarily to address and status, Figure 9.

To summarize, in-circuit emulation has been available on a range of development systems for several years, where it has proven its usefulness as part of the product development cycle. The appearance of low-cost, stand-alone emulators should widen the appeal of the technique.

A list of suppliers follows. ▶



Figure 6. MICE can be operated from a VDU, or, as shown, from a computer system running a driver routine.

```

>2
ASSEMBLY           A loc
BACKWARD TRACE    B [R] addr[c|q]
CYCLE STEP        C
DISABLE           D NIIHIC
ENABLE            E NIIHIC
FORWARD TRACE     F [R] addr[c|q]
EXECUTION         G [a|[:a2]]
BREAKPOINT       H [0|1|2]|| addr[c|q]||2 addr|
INPUT            I port[c|time]
JUMP             J a|[:a2]
LIST TRACE       L [step|a|a2|q]||I|S|step|
MEMORY          M [C|S|D|S|S|S|E|S] a|a2|d|d|
OUTPUT          O port d|d2|d3|d4|
REGISTER        R [A|X|B|X|C|X|D|X|S|P|B|P|S|I|D|S|E|S|S|S|C|S|I|P|F|S]
INSTRUCTION STEP S [S|c]
TRANSFER/TEST   T [C|S|D|S|S|S|E|S] a1 a2 S|M|a3
UPLOAD          U a1 a2 [TH]
RESET           X [a|[:a2]]
DISASSEMBLY     Z a|[:a2]
DOWNLOAD        (INT),(TEK)
HELP            ?
ATTENTION      !
>

```

Figure 7. MICE command summary.

```

>Z 8000 8010
LOC      OBJ          LINE   LABEL   SOURCE CODE
8000     200680       0001           JSR 8006
8003     4C0080       0002     B8000   JMP 8000
8006     A904         0003           LDA #04
8008     8D1180       0004           STA 8011
800R     CE1180       0005     B800B   DEC 3011
800E     D0FB         0006           BNE 800B
8010     60           0007           RTS

```

DISASSEMBLY COMPLETED

Figure 8. Two-pass disassembler on MICE.

## FEATURE

(Reprinted from Electronics & Wireless World, by arrangement with the publisher.)

### SUPPLIERS

Alfatron Pty Ltd, 1761 Fern Tree Gully Rd, Fern Tree Gully, Vic 3156. (03)758-9000.  
 Datacraft Office Systems Pty Ltd, 529 Birdwood Rd, Hawthorn, Vic 3122. (03)818-0741.  
 Datatel Pty Ltd, 19 Raglan St, South Melbourne, Vic 3205. (03)690-4000.  
 Elmeasco Instruments Pty Ltd, 15 McDonald St, Mortlake, NSW 2137. (02)736-2888.  
 Hewlett Packard Pty Ltd, 31 Joseph St, Blackburn, Vic 3130. (03)895-2895.  
 Intel Aust Pty Ltd, 200 Pacific Hwy, North Sydney, NSW 2060. (02)957-2744.  
 Kenelec Pty Ltd, 48 Henderson Rd, Clayton, Vic 3168. (03)560-1011.  
 Macro Dynamics, 66 Barry St, Bayswater, Vic 3153. (03)762-6800.  
 Motorola Semiconductor Products, 666 Wellington Rd, Mulgrave, Vic 3170. (03)561-3555.  
 Parameters Pty Ltd, 41 Herbert St, Artarmon, NSW 2064. (02)439-3288.  
 Tech Rentals Pty Ltd, 12 Maroondah Hwy, Ringwood, Vic 3134. (03)879-2266.  
 Tektronix Pty Ltd, 80 Waterloo Rd, North Ryde, NSW 2113. (02)888-7066.

Figure 9. Trace analysis with Microtek's MICE II.

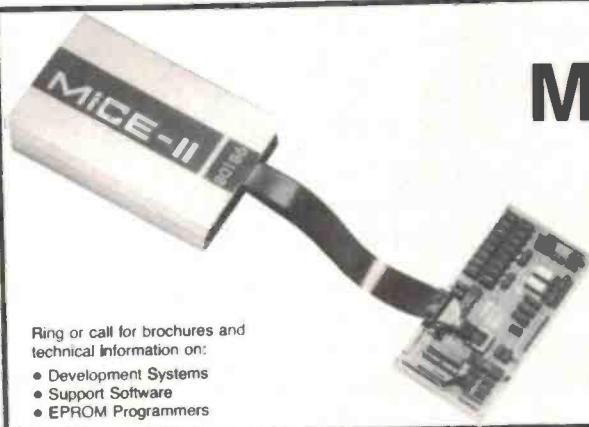
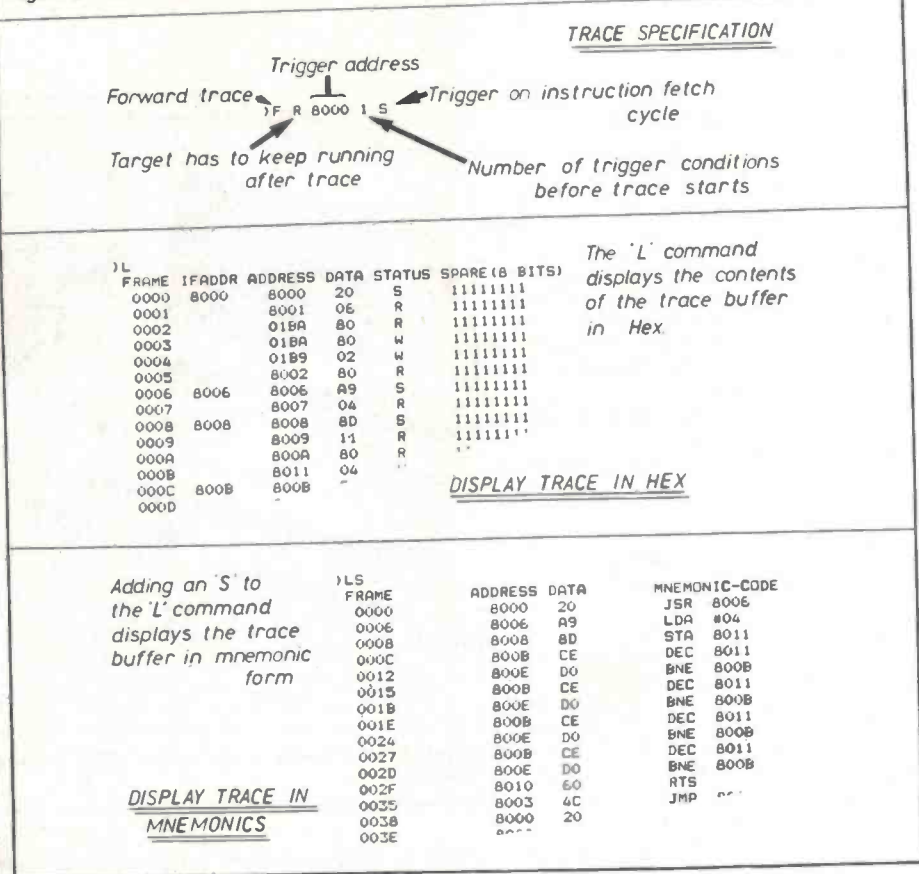

## The cost effective solution MICE-II IN CIRCUIT EMULATOR

Manufactured by Microtek International Inc.

- ### THE BIG SELLER BECAUSE . . .
- It's powerful
  - Supports a wide variety of microprocessors
  - Drivers available for IBM-PC and many other systems
  - Doesn't cost the earth

**MACRO DYNAMICS** Australian Distributor  
 66 Barry St, Bayswater Vic (03) 762 6800 Tlx AA30674 NSW (02) 85 3050  
 New address as of mid March: 80 Lewis Road, Wantirna South, 3153. Phone: 220-7260.

Ring or call for brochures and technical information on:

- Development Systems
- Support Software
- EPROM Programmers

# Two Wheels

ON SALE AT YOUR NEWSAGENT EVERY MONTH

# SOANAR THE POWER DISTRIBUTOR

FOR



**MOTOROLA  
SEMICONDUCTORS**



**Discrete Devices  
Microprocessors  
Digital Integrated Circuits  
Linear Integrated Circuits**

Available ex stock all states.

**SOANAR**

**SOANAR ELECTRONICS PTY. LTD.**

INCORPORATED IN VICTORIA

30-32 Lexton Road, Box Hill, Vic., 3128, Australia.

Telex 34303

VICTORIA: 895 0222

N.S.W.: 789 6744

STH. AUST: 297 0811

QUEENSLAND: 852 1133

WEST AUST: 381 9522

TASMANIA: 31 6533

## PCB TRANSFORMERS

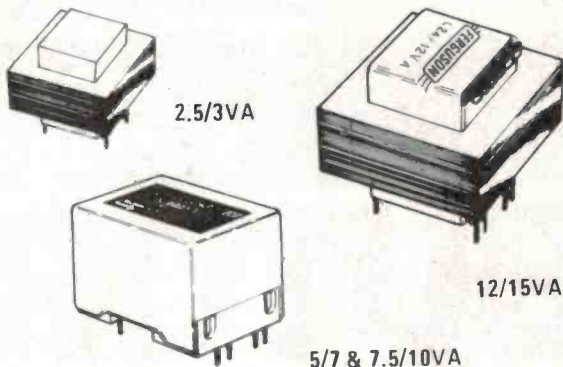

- Manufactured to AS3126 and Telecom approved
- Suit standard PCB grids and simplify construction

## POWER TRANSFORMERS

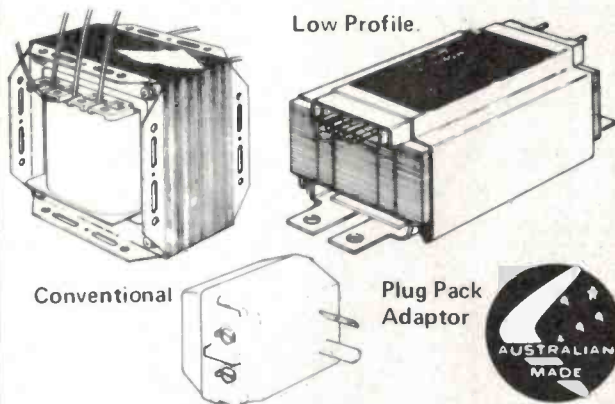

- Wide range of secondary voltages from 1.5V to 115V
- Stock range has ratings up to 1000VA
- Special types for microprocessors, 115V etc

## AUDIO TRANSFORMERS

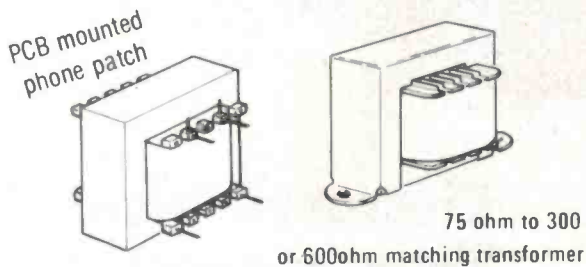

- Line and Matching transformers up to 150W
  - Power transformers for high power amplifiers
  - Transistor drivers
  - Special 'C' core transformers
- Ask for MAL VK2BMS or DOUG VK2BPX

TALK TO FERGUSON - THE AUSTRALIAN COMPANY  
WITH NEARLY 50 YEARS EXPERIENCE OF MANUFACTURING  
IN AUSTRALIA FOR AUSTRALIAN CONDITIONS

Ferguson Transformers Pty. Ltd.  
331 High Street, Chatswood 2067. Tel: (02) 407-0261.  
Telex: AA25728. Melbourne: (03) 561-6699.

**FERGUSON**

# What is better than NiCad for memory back-up?

## NEC



COMPARATIVE SIZE

# SUPERCAP of course!

Unlike NiCad —

- It never needs replacing or maintenance.
- It does not exhibit discharge memory.
- It can be wired either way. Lack of polarity enables this.
- It can be soldered onto P.C.B.s with other components.
- It can be charged at high and low current rates, i.e. microamps to amps.
- It is completely safe. It will not explode under extremes of temperature, nor will it leak.
- It is small and compact.

Catalogue No.	Cap. (Farad)	Rated V. (V.D.C.)	Max. W.V. (V.D.C.)	Max. ESR* (Ω at 1 kHz)
FA0H105Z	1.0	5	5.5	2.5
FZ0H223Z	0.022	5	5.5	50
FZ0H473Z	0.047	5	5.5	40
FZ0H104Z	0.1	5	5.5	45
FZ0H224Z	0.22	5	5.5	25
FZ0H474Z	0.47	5	5.5	13
FZ0H105Z	1.0	5	5.5	7

\*Equivalent series resistance

TECHNICAL INFORMATION AVAILABLE ON REQUEST. JN

# SOANAR

SOANAR ELECTRONICS PTY. LTD.  
INCORPORATED IN VICTORIA

30-32 Lexton Road, Box Hill, Vic., 3128, Australia.

VICTORIA: 895 0222  
N.S.W.: 789 6744  
S.T.H. AUST. 297 0811

QUEENSLAND: 852 1133  
WEST. AUST.: 381 9522  
TASMANIA: 31 6533

# SUPERCAPS

When is a capacitor more than just a capacitor? When its capacitance is so big that the charge it stores can run a circuit for a significant period of time . . .

Jon Fairall

THE SUPERCAP IS HERE. All 1 000 000  $\mu\text{F}$  of it (that's right, one Farad!). Negate your Nicads. Levitate your lithiums. The world of the future belongs to a cap no bigger than a fifty cent piece.

According to NEC, who has announced its release in Australia, the FZ and FA series capacitors will be available in 0.022 F, and 1 F versions. Sizes vary slightly over the ranges but the F2 series 1 F is 28.5 mm across by 25 mm high. And that is just about as big as they come.

The first thing that comes to mind is that a capacitor like this would make a magnificent power backup source. Just how good can be seen from Figure 1, which shows the time taken to loose 10% of the initial charge. As one would expect it depends on the current drawn, but the figures are staggering nevertheless. For instance the FA series 1 F capacitor will supply 10 mA for 50 seconds, or 100 mA for 5 seconds.

Used in conjunction with CMOS technology, where current drain is measured in microamps, the figures are even more impressive. The FZ version 1 F supercap will supply 60  $\mu\text{A}$  for a whole day, while maintaining a voltage above 40% of the original (see Figure 2).

NEC has claimed that a supercap will maintain a 1k byte CMOS RAM for more than 30 days and a  $\mu\text{PD7507C}$  microcomputer for more than a day. If it is desired to improve these figures there is nothing to stop a designer connecting supercaps in series or parallel to increase the working voltage or the total capacitance (and thus the backup time, see Figure 3).

As one might expect, the supercap is not the result of ordinary capacitor technology. You don't generate figures like those above by winding up strips of aluminium in plastic tape.

The supercap is an 'electric double layer' capacitor. An electric double layer is the name given to the area around the interface of two dissimilar materials, where charged particles exist. In the supercap there are two materials: an activated carbon and a slightly damp solution of sulphuric acid in an electrolyte. When a charge is applied across the junction, charged particles congregate at the interface. In our case the carbon hosts the

positive ions, the electrolyte the negative ones (see Figures 4 and 5).

The charge is actually contained in the ions. NEC claims that the capacitance obtained in this way is between 20 and 40  $\mu\text{F}/\text{cm}^2$ . Notice that the capacitance depends on the actual physical area of the interface. If you want large capacitance, you need large areas. At first sight this might seem to mean that large capacitance must lead inevitably to large capacitors,

but this need not be necessarily so.

The activated carbon used in the supercaps is specially processed to achieve very high porosity, so that the interface surface area is greatly increased. The same principle is used in air cleaners, where it is necessary to bring a very large surface area into contact with the air. In fact, it is possible to achieve a surface area of 10 000 000  $\text{cm}^2$  with every gram of carbon.

Some simple multiplication will show

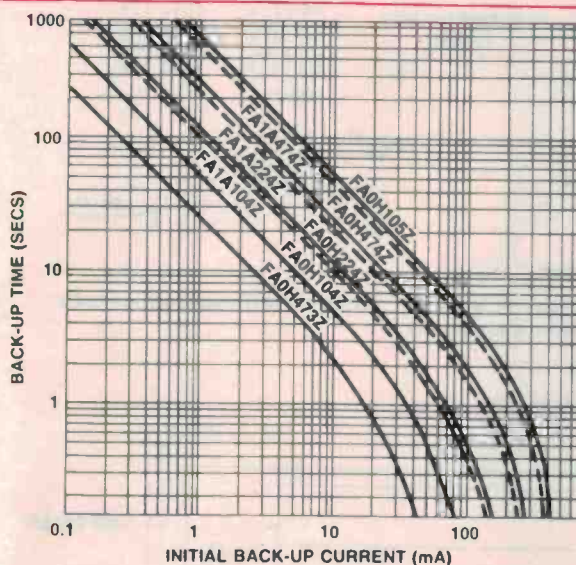

Figure 1: Time versus current as voltage decays from 5 V to 4.5 V.

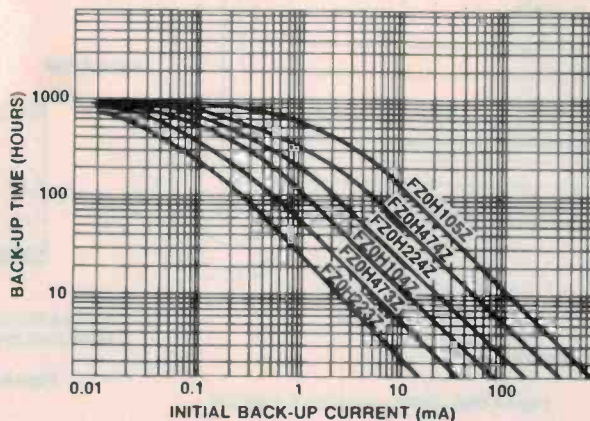

Figure 2: Time versus current for a voltage drop from 5 V to 2 V.

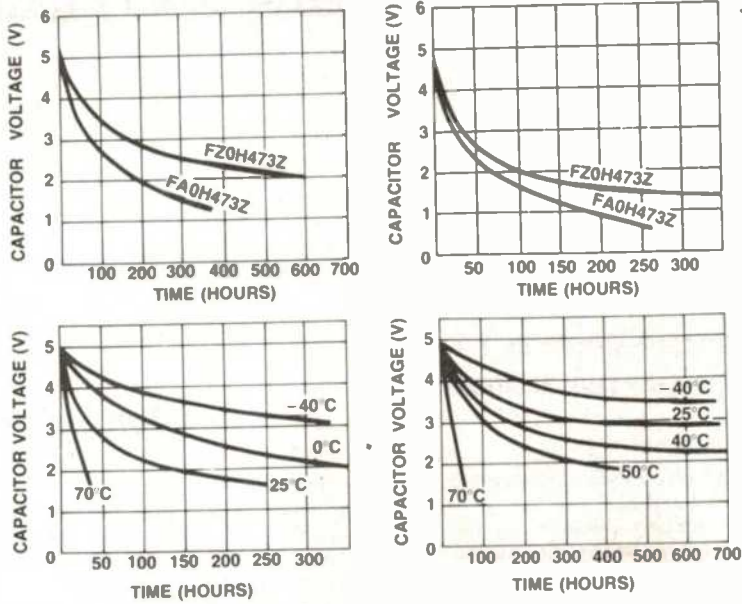

Figure 3: The discharge characteristics of the FZOH372Z supercap with a variety of loads.

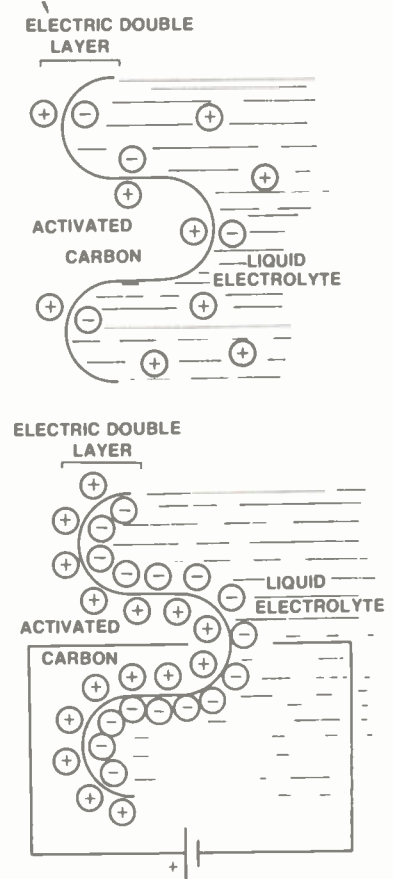

Figure 4: A schematic representation of the interface between the carbon and electrolyte in a supercap. At left, no charge is applied, and the ions are spread throughout the material. At right, a potential exists across the interface and the ions cluster as shown.

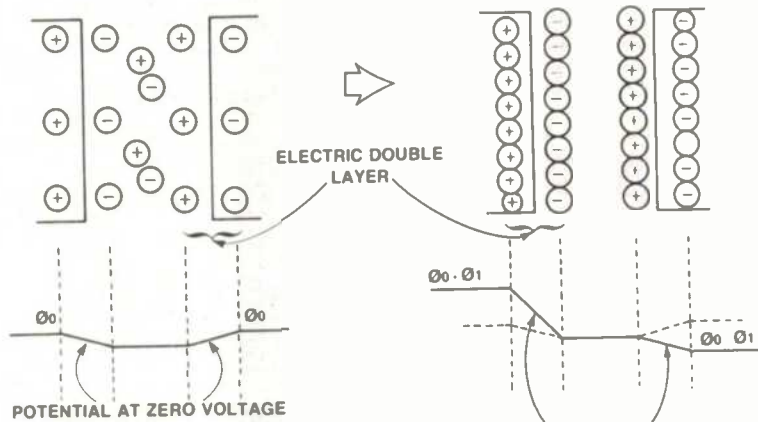

Figure 5: The electric double layer. At left is no potential, at right, the double layer is shown with potential applied.

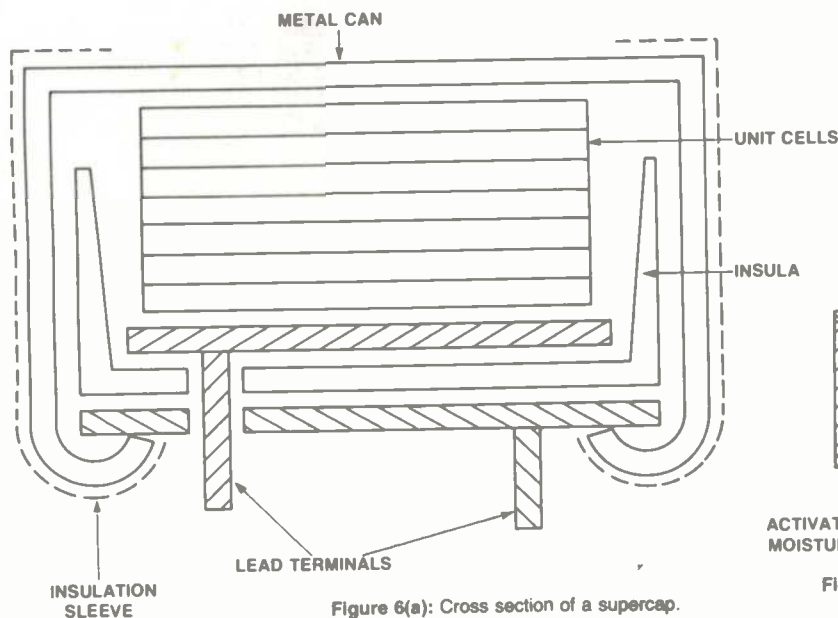

Figure 6(a): Cross section of a supercap.

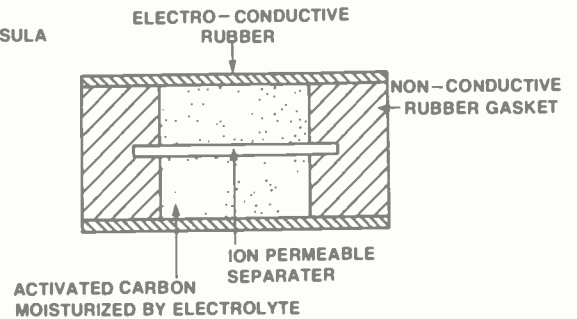

Figure 6(b): A single unit cell of a supercap. Maximum voltage is about 1.2 Volts.



you that this means one gram of activated carbon used in this mode will produce between 200 and 400 Farads worth of capacitance.

In practice, a supercap is constructed rather like a battery, with a number of cells. Each cell has a breakdown voltage of about 1.2 V and the total breakdown voltage of the capacitor is determined by the number of cells connected in series that go to make up the whole unit. Most of the supercaps are rated at 5 V, although a few are rated at 10 V.

Each cell is constructed (see Figure 6) of two layers of activated carbon separated by an ion-permeable separator. The cell is contained in a non-conductive rubber gasket with electroconductive rubber ends (for connection to other cells). The whole unit is vulcanised together to hermetically seal in the contents. To create a working capacitor, a number of these units are stacked on top of each other and placed in a metal can. Contact with the outside world is via two leads that contact with either end of the stack.

The result is a device with many of the desirable features of large capacitors and batteries, without most of their disadvantages. Like a capacitor, the supercap can be charged and discharged as often and as fast as required without any ill-effects. Unlike batteries, there is no need for a special charging circuit and no 'discharge memory' effect.

Unlike both batteries and other large capacitors, the supercap has a life expectancy as long as most of the components it will be associated with. It does not 'dry out' the way other large capacitors do, firstly because each cell is sealed, and secondly because the moisture content of the electrolyte is very small to start with. Unlike a Nicad, its life expectancy is quite independent of the number of charge cycles it has undergone.

Another advantage is that if it does fail, a supercap will usually fail with its leads open circuit rather than short circuit the way most conventional capacitors do. If it is subject to excessive voltage and/or heat, the electrolyte may start gassing (i.e. vapourising). Under these conditions there may be a loss of contact between the electrolyte and the conducting rubber, resulting in an open circuit.

As one would expect there are a number of disadvantages one can point at when looking at supercaps. For a start, they are not suitable in smoothing operations. They have a relatively high internal resistance, and as a result will develop too much ac ripple voltage across them in most smoothing applications.

Another problem is that they are very limited in their maximum working voltage. The decomposition of the electrolyte limits the voltage across each cell to about 1.2 V. In theory it is possible to stack as many as one likes in series to create as high a working voltage as required. How-

ever there are impediments to developing this idea to the nth degree. As the number of cells increases so does the series resistance, and so does the physical size of the capacitor. For this reason NEC has decided to restrict construction to 5 and 10 V models.

From the point of view of the manufacturer there is a further disadvantage, namely that both solvents and ultrasonic cleaners may have bad effects on the capacitors. Both these cleaning methods are in common use after boards have been through automatic insertion and soldering equipment.

Figure 7 shows the standard method of using a supercap as a power backup. Resistor  $R_c$  is a current limiting resistor, and should be defined by the maximum current capacity of the power supply. At the start of charging a supercap will draw 50 mA. (It takes about fifteen minutes to charge to within 0.4 V of the power supply.) The diode is used to decouple the capacitor from the power supply in the event of the latter's failure. The only other consideration that one needs to bear in mind is that for maximum usefulness the supercap should be placed as close as possible to the device it is going to sustain.

Supercaps necessitate a complete re-think of the way designers attack the problem of backup power. They do not provide the total answer, if only because of their limitations on voltage. But for most computer applications, they represent a significant step forward.

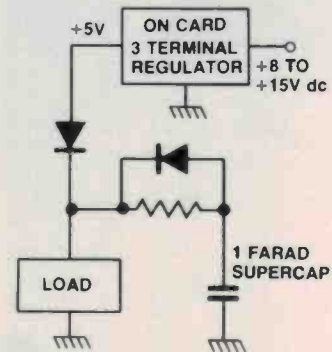
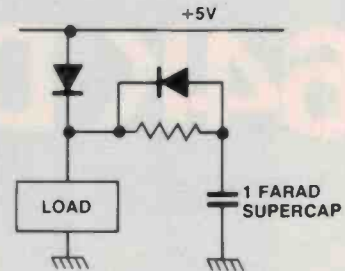
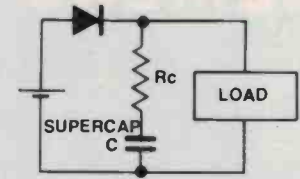
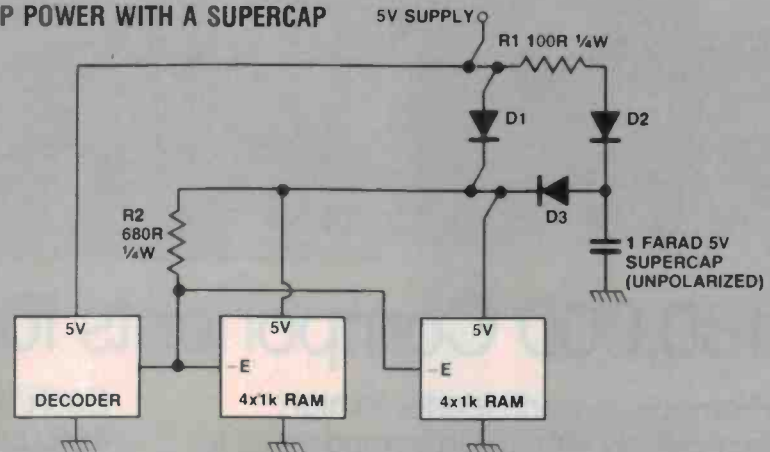

Figure 7: Three possible back up configurations.

## BACKUP POWER WITH A SUPERCAP



A 1 F supercap draws 50 mA at the start of charging. Diode D3 isolates the RAM chips from the voltage across the capacitor as it slowly charges. It takes about 15 minutes to charge within 0.4 V of the supply voltage.

The diodes are Schottky types that offer low forward resistance and low reverse-bias leakage current. When power fails, the power supply is isolated from the supercap by diode D2 and from the RAM diode D1. The decoder goes high, ensuring that the RAM will not be selected during power failure (supercap holds the chip-enable line high). Resistor R2 must be small (680 ohms) to hold up the decoder output stage, because the pull-down transistor turns on (briefly) and draws a little current during power shutdown.

All RAM address, data, and control lines (except chip enable) should be held low by 4.7 k resistors during power-off to prevent the input stages of the CMOS RAM devices from drawing high current. A power-detect circuit and appropriate software could be included to ensure that RAM is not being written to when the power fails.

**SIEMENS**

# 64K DRAM IC4164

**NOW  
JUST  
\$2.99\*  
EACH!**  
While stocks last.



## 180,000 Components for Peanuts!

Siemens, a world leader in high technology electronic components is even better known for relentless quality control. And now Siemens is offering memory I.C.'s at a lower price.

Both 128 and 256 refresh cycle I.C. memory parts are available immediately.

Each 16 pin dual in line package delivers 180,000 components – mostly transistors and capacitors – in its silicon chip. That's more than 600 components for less than 1 cent!

Siemens Ltd.  
544 Church Street, Richmond, Vic. 3121.  
Telephone: 420 7318 Sydney 436 8730

**Siemens Memory I.C.'s. High quality. New low price.**

\*Minimum order of 100 + pieces, plus sales tax if applicable.

Cash sales facilities available for non account customers.

CSA 2430/744



### CANNON TYPE AUDIO CONNECTIONS

We've sold 1000's because of their great value!!

3 Pin line male 1-9 10+  
Cat. P10960 \$1.90 \$1.80

3 Pin chassis male  
Cat. P10962 \$1.90 \$1.80

3 Pin line female  
Cat. P10964 \$2.50 \$2.20

3 Pin chassis female  
Cat. P10966 \$2.90 \$2.70



### BULK CABLE 100M ROLLS

Cat. W11222 3C2V75 OHM \$22.00

Cat. W11224 5C2V75 OHM \$35.00

Cat. W11219 4 Core Shielded \$49.00

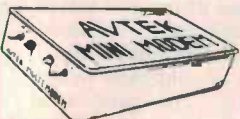

**MINI MODEM**  
300 baud full duplex  
Answer originate  
Plugs straight in (hardwired phone)  
Superior VLSI chip performance identical to Multi Modem  
Telecom Approval (C84/37/1173)

Incl. phone only \$199

### ALUMINIUM SHEETS

8mm	SIZE	PRICE
H10770	150x150mm	\$1.75
H10771	150x300mm	\$2.50
H10772	300x300mm	\$3.95
H10773	300x600mm	\$6.90

### HEX KEY PAD

19 Keys, Unencoded, 76 x 95mm  
Cat. K46804 \$42.50

### RECHARGEABLE 12V GELL BATTERIES

Leakproof and in 3 convenient sizes, these long service life batteries are ideal for burglar systems, emergency lighting or as a computer backup power supply. Ideal for many power needs.

Cat. S15029 12V 1.2 AH \$17.95

Cat. S15031 12V 2.6 AH \$34.50

Cat. S15033 12V 4.5 AH \$44.95

### BLANK DATA CASSETTES

Brings out the best in any micro!

1-9 10-99 100  
\$1.10 \$1.00 \$0.90

Cat. D11141

### PRIME SPEC RED LEDS

We bought 100,000 so you can reap the benefits!

1-9 10+ 100+ 1,000+  
10c 9c 8c 7c

Cat. Z10150



**NEW SLOPING CASES**  
Plastic with metal front panel, available in two sizes.

Cat. H10450 \$9.95  
190x120mm  
Cat. H10455 \$17.95  
265x185mm (measurements are approx. only)



**HEAT STOPPERS**  
For protecting parts which have little resistance against heat when soldering. Normally \$3.50.

Cat. T12440 \$2.50



**RS232 & 'D' TYPE CONNECTORS**

PART	DESCRIP.	CAT. NO.
DE 9P	9 Pin Female	P10880
DE 9M	9 Pin Male	P10881
DE 9C	9 Pin Cover	P10882
DA 15P	15 Pin Male	P10894
DA 15S	15 Pin Female	P10895
DA 15C	15 Pin Cover	P10892
DB 25P	25 Pin Male	P10900
DB 25S	25 Pin Female	P10901
DB 25C	25 Pin Cover	P10902

### 36 WAY CENTRONICS CRIMP PLUG

Cat. P12200

1-9 10-99 100+  
\$6.95 \$5.95 \$5.50

### SOLDER CENTRONICS PLUGS

Unreal price for absolute top quality. Normally \$14.95 (Our opposition charge up to \$19.95)

1-9 10+ 100+  
\$6.95 \$5.95 \$4.95

### CENTRE RETURN JOYSTICK

Features 2 x 150K pots long shaft 40mm with 25mm control ball Bonus adjustable offset feature on pots

Cat. X15637 1-9 10+  
\$9.95 \$8.95



**PIPER MOUSE ROBOT**  
This is a Super-Sonic robot, controlled by a super-sonic sound sensor and an electronic circuit. (1 channel). By using the whistle included with this Kit, Piper Mouse will obey your commands immediately turning to the left, stop, turning to the right, stop, advance and stop.

Cat. K96680 \$34.95



**SWITCH MODE POWER SUPPLY**  
DC +5V @ .5A +12V @ 4A  
DC -5V @ .5A -12V @ 4A

Cat. M16680 \$89



**JUMPER LEADS**  
Set of 10 high quality leads approx. 300mm long. Normally \$4.95.

Cat. W12000 \$2.95

### NICAD BATTERIES

Save on carbon batteries with these Apolon Nickel Cadmiums. Rechargeable up to 1000 times!

Cat. S150020 AA500 MA \$2.25

Cat. S15021 C 1.8 AH \$4.95

Cat. S15022 D 4 AH \$3.95

1-9 10+  
\$2.25 \$1.95  
\$4.95 \$3.95  
\$7.95 \$6.95

### LOW PROFILE IC SOCKETS

How cheap can they go?

8 pin Cat. P10550 15c 14c 12c 09c

14 pin Cat. P10560 16c 15c 14c 10c

16 pin Cat. P10565 17c 16c 15c 11c

8 pin Cat. P10567 18c 17c 16c 13c

20 pin Cat. P10568 29c 28c 27c 26c

24 pin Cat. P10570 35c 33c 32c 28c

40 pin Cat. P10575 45c 40c 35c 30c

### APPLE JOYSTICKS

Ideal for games or word processing. Fits most 6502 compatible computers.

Cat. C14200 \$24.95



**VERBATIM DISKS**  
"Lowest" price possible for "Highest" quality.

1-9 10+ 100+  
MDS25-01 3.95 2.75 2.50  
MDS50-01 4.50 3.95 3.75

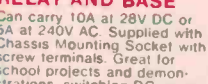

**RELAY AND BASE**  
Can carry 10A at 28V DC or 5A at 240V AC. Supplied with Chassis Mounting Socket with screw terminals. Great for school projects and demonstrations, switching DC power supplies, central circuits and with contacts parallel up to 20A can be switched.

Normally \$8.95

Cat. S14074 This month \$6.95



**ELECTRONIC CASSETTE DEMAGNETISER**

Save \$2. Rec. retail \$19.95

Cat. A10006 This month \$17.95

### ECONOMY TOGGLE SWITCHES

Unbelievable Value!

1-9 10+ 100+  
S11010 .SPDT \$1.00 \$0.90 \$0.80  
S11020 .DPDT \$1.20 \$1.00 \$0.90

### 10,000uF 75V ELECTROS

25% more microFarads! Ideal for those who want a more powerful amp!

1-9 10+  
Cat. R16587 \$10.50 \$9.00

### NEW JOINABLE PCB MOUNTING SCREW TERMINALS

Less than half the price of the old ones!

2 way 1-9 10+  
Cat. P10542 \$0.50 \$0.40

3 way  
Cat. P10543 \$0.75 \$0.65 (please note these are the new blue ones.)

### LOGIC PROBE 3800A

Features 20MHz memory TTL CMOS operation. Normally \$29.50 now only \$19.50

1-9 10  
Cat. Q11272 \$17.50

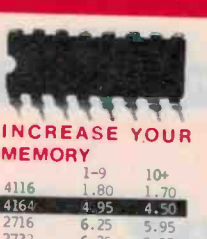

**INCREASE YOUR MEMORY**

	1-9	10+
4116	1.80	1.70
4164	4.95	4.50
2716	6.25	5.95
2732	6.25	5.95
2764	8.25	7.95
27128	27.00	25.00
6116	6.95	6.75
41256	27.50	22.50



**BULK 'IC' SPECIALS**

	10+	100+	1000+
LM324	\$0.70	\$0.65	\$0.60
LM339	\$0.70	\$0.65	\$0.60
LM555	\$0.40	\$0.39	\$0.35
LM723	\$0.60	\$0.55	\$0.53
LM741	\$0.45	\$0.40	\$0.37
LM1458	\$0.80	\$0.70	\$0.65
LM1488	\$0.60	\$0.57	\$0.55
LM1489	\$0.60	\$0.57	\$0.55



**PHILLIPS SPEAKER SPECIAL**

Cat. C12030 AD01610 T8 \$12.95

Cat. C12040 AD02160 S08 \$34.95

Cat. C12045 AD70620 M8 \$49.00

Cat. C12050 AD12550 W8 \$79.00



**SUPER HORN TWEETER**  
Wide dispersion tweeter, handles up to 100W! Sensitivity: 105dB/0.5m Frequency Response: 3kHz-30kHz Impedance: 8 OHMS Size: 145x54mm

Cat. C12103 \$12.95



**SUPER HORN TWEETER**  
Requires no crossover and handles up to 100W! Sensitivity 100dB/0.5m Frequency Response: 3kHz-30kHz Impedance: 8 OHMS Size: 96mm diameter

Cat. C12102 (Rec. Retail \$12.95) \$11.95



**FULL STRENGTH FERRIC CHLORIDE**  
This month only!

250ml \$1.95 \$1.75  
500ml \$2.95 \$2.50  
1 litre \$4.95 \$4.50

# rie

Rod Irving Electronics  
425 HIGH STREET, NORTHCOTE VICTORIA.  
PH:(03)489 8866 489 8131  
48-50 A'BECKETT STREET, MELBOURNE VICTORIA.  
PH:(03)347 9251

Mail Order and correspondence:  
P.O. Box 235 NORTHCOTE 3070

Call in at either 2 of our conveniently located stores:  
48-50 A'Beckett St., Melbourne  
425 High St., Northcote.

Or take advantage of our Mail Order Department.

Write to:

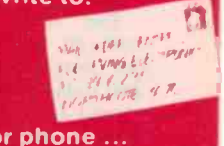

### or phone ... MAIL ORDER HOT LINE



POSTAGE RATES

\$1-\$9.99	\$1.50
\$10-\$24.99	\$2.00
\$25-\$49.99	\$3.00
\$50-\$99.99	\$3.50
\$100-\$199	\$5.00
\$200-\$499	\$7.50
\$500 plus	\$10.00

Comet road freight is extra



**PROJECT ELECTRONICS**  
Here are 11 great projects for the beginners from the ETI Project Electronics publication (5th Edition)

043 Heads of Tails \$3.90  
044 Two tone doorbell \$4.90  
047 Morse practice set \$3.90  
048 Buzz board \$4.50  
061 Basic Amplifier \$5.90  
065 Electronic siren \$5.90  
066 Temperature alarm \$5.50  
067 Singing moisture meter \$7.95  
068 LED dice \$6.90  
072 Two octave organ \$9.50  
084 Car alarm \$13.50

All these Kits are available from us at Rod Irving Electronics!

Cat. B11185 \$4.75  
OR "FREE!" with every order for 10 or more Kits!!

Errors and Omissions Excepted

# Better performance for Z80 software

**THE NEW Z800 Microprocessor can be used to upgrade existing Z80 software increasing its performance up to 12 times — with no program modifications.**

The Z800 Family provides both an 8-bit non-multiplexed bus design (compatible with the Z80 device) and a 16-bit multiplexed bus design (compatible with the Zilog Z8000 Family).

On-chip features improve performance. Cache memory and other on-chip peripherals plus an enhanced, high performance instruction set allow the Z800 CPU chip to operate at up to 25 MHz and to execute one to five million instructions per second.

An on-chip Memory Management Unit (MMU) extends the Z800 CPU's logical addressing space to up to 16M bytes. Borrowing a successful strategy from popular 16-bit minicomputers, the MMU divides the Z800 addressing space into pages that are then mapped into the larger physical memory space.

A 256-byte, on-chip memory cache gives the Z800 processor high-speed access to instructions and data that usually are kept in external memory. As a result, the Z800 CPU can operate efficiently with a wider variety of memory devices — including those operating at a much lower speed.

Built-in peripherals reduce system space. The Z800 CPU provides four DMA channels, three counter/timers, one timer, a universal asynchronous receiver/transmitter (UART) an interrupt controller, a dynamic RAM refresh mechanism, and a clock oscillator.

The Z800 processor contains the entire Z80 CPU instruction set plus additional enhancement, hardware multiply and divide, 16-bit arithmetic, 16-bit load and system call, test and set. A special group of extended processing instructions allows the device

to operate with Zilog's new Z8070 floating-point processor.

Separate operating modes protect time-critical tasks from background tasks. Like the Z8000 CPU, the Z800 processor separates system and user modes to run the operating system and application tasks, respectively. As a result, the Z800 processor isolates and protects time-critical tasks from disruption by user or background tasks when working in a multitasking environment.

For further information contact **The George Brown Electronics Group, 174 Parramatta Road, Camperdown, NSW 2050. (02)519-5855.**

## Utilux explains 'Le Pin'

THE PRECICONTACT PIN, a two-piece construction with a tapered entry socket for easy insertion of IC legs, is becoming available in an increasing number of configurations. According to its Australian distributors Utilux Pty Ltd, it is one of the best available for precision IC sockets and components.

'Heart' of the pin is a four leaf beryllium copper contact which component accommodates 0.20 x 0.38 mm to 0.38 x 0.53 mm leads. The contacts are burnished and plated all over in controlled batches which the maker, Precimont, claims ensures quality control, reliability and resistance to corrosion. The brass sleeves are also precision made and have closed end construction which eliminates solder and flux wicking problems.

Utilux has announced release of a number of sockets using the Precicontact Pin which includes UH high temperature sockets, LED sockets and pin grid array sockets.

The series UH high temperature sockets are of the open in-

ulator type available six to 40 ways. The pin housing is made from glass filled polyphenylene sulphide UL-94V-0 and the socket is claimed to meet the severe environmental operating conditions, with an operating temperature of -65°C to +250°C.

The new LED sockets (Series LED) use the Precicontact Pin and are also available in six to 40 ways, in a housing of glass filled polyphenylene sulphide UL94V-0.

A new range of pin grid array sockets is available in a larger variety of configurations with either solder or solderless wrap tail terminals. The pins are housed in glass epoxy, GIO, 1.57 mm thick and are useful as working tools for construction of bubble memory banks for computers and microprocessors and for bread boarding and prototype build programmes.

Further information contact **Utilux Pty Ltd, 74 Commercial Road, Kingsgrove NSW 2208. (02)50-0155.**

The Precicontact pin. It is available in a range of sockets including high temperature sockets, LED sockets and pin grid array sockets. Its plated design improves reliability and resists corrosion. ▼

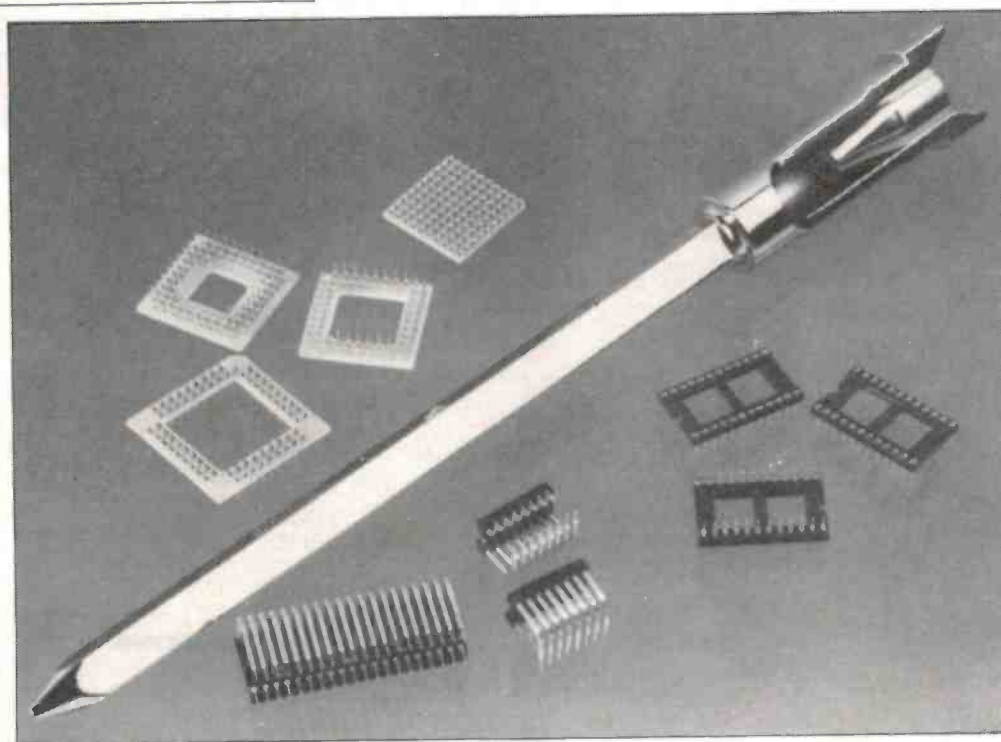

## Multi-tap power supplies for 3-12 volts

THERE ARE several ways of reducing the high cost of replacement batteries. One method is to use rechargeable batteries of the nickel cadmium type. These offer extremely good performance and long life as they can be used and re-charged up to 1000 times.

Another way is to run products from 240 volt mains electricity via a battery eliminator. This provides the correct voltage and current and has the added advantage that no deterioration in performance is experienced as happens with batteries from the moment they are installed.

Arlec Pty Ltd has just introduced a new plugpack battery eliminator under its Part No. PS699 which will power the majority of small battery operated products on the market.

Because it is a plugpack, the battery eliminator itself plugs

directly into the 240 V mains socket thus keeping the installation simple, neat and tidy. The supply lead is fitted with a modified cruciform plug which provides a choice of six different connectors to suit the majority of input sockets fitted to different manufacturers' products.

A switch on the plugpack selects any one of the six voltages available (3, 4.5, 6, 7.5, 9 and 12 volts) and the 500 mA current capability is usually more than adequate for the items to be powered.

The new in-line polarity reversing plug is the subject of a patent application.

Further details on the PS699 battery eliminator and Arlec rechargeable batteries are available on application to Arlec Pty Ltd, 30 Lexton Road, Box Hill, Vic 3128. (03)895-0222.



## A new low-profile, double-pole switch

BURGESS HAS announced a new, low-profile switch, designed and developed with the current vogue in slim-line telephones in mind.

Based on the Burgess V4 mechanism, the new switch is double-pole and has changeover or single-throw options; the electrically isolated circuits are actuated by a common plunger. Terminals are suitable for pc board mounting and are spaced on the international 0.1 inch grid.

Positive sequencing between poles can be provided, if required. Silver contacts are standard. Gold-plated contacts suitable for low-voltage applications may also be specified if required.

The switch has been designed to accept a range of actuators.

A matching single-pole version will follow in the near future providing optimum versatility for multi-pole switching.

Available from Australian distributor Bellco Controls/Email Ltd Relays Division.

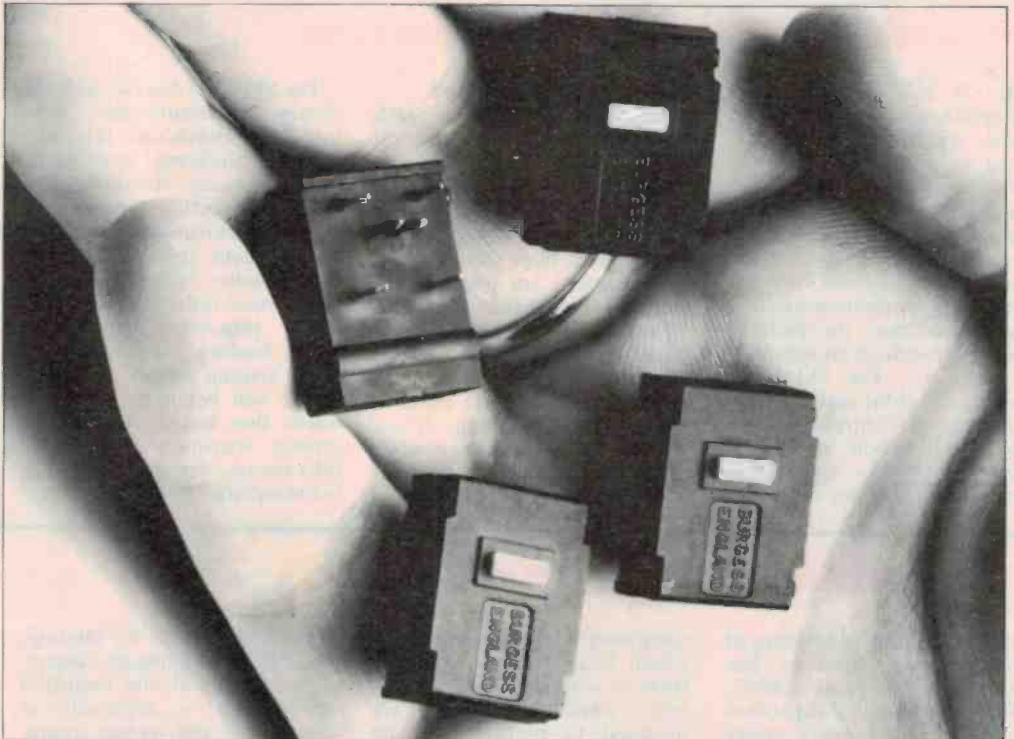

Tell them you read it in ETI

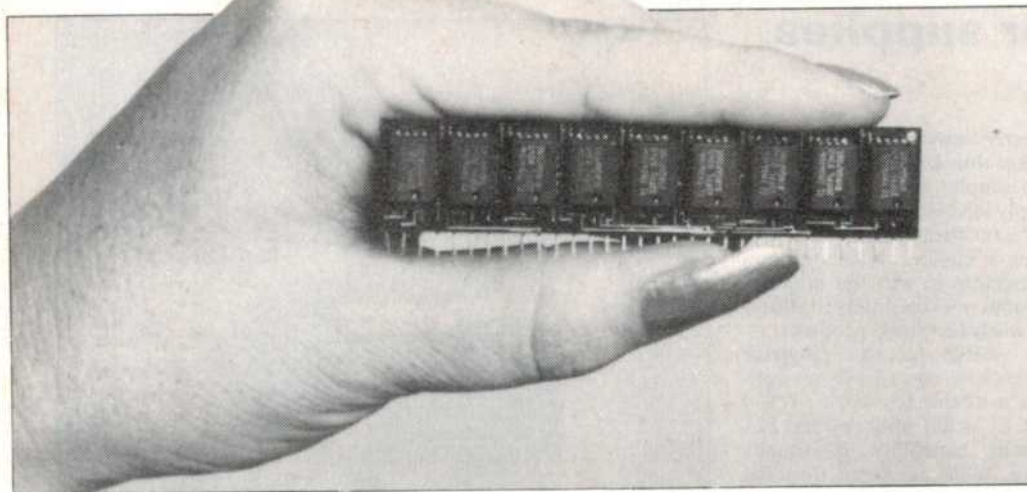

### High density dynamic RAM family

TEXAS INSTRUMENTS has released a new family of low cost, high density, dynamic random access memory (DRAM) modules. The modules are organised in a single-in-line package (SIP) and use plastic leaded chip carriers.

The new TM416EC4 organised 64K x 4 can provide up to 3.5 times as much memory in the same board area as conventional

dual-in-line package (DIP) DRAMs.

Other members of the new family, the TM4164EL8 (64K x 8 SIP), and the TM4164EL9 (64K x 9 SIP) allow even further reductions in board area. SIPs can also reduce system costs through improved reliability and they provide an easy upgrade path for next generation memory modules.

Principal uses for the 64K x 4/64K x 8 products include mainframe and super minicomputers memory modules, personal computers and other applications where the physical size of the equipment is dependent on memory system size.

With the SIP approach to memory system design, claims the company, several benefits are provided for the product de-

signer. The number of plated through-holes can be reduced, lowering board cost and decreasing the number of board layers. Each 64K x 8 block of memory can reduce 128 plated through-holes to 30, and using on-SIP capacitors eliminates the need for bypass capacitors on the motherboard and gives superior performance over equivalent leaded capacitors due to diminished lead inductance. This improvement, combined with shortened pc trace lengths and reduced capacitance, lowers system noise and increases speed potential.

The TM4164EC4, TM4164EL8 and TM4164EL9 are the first members of a family of compatible SIP modules built using Texas Instruments DRAMs in plastic leaded chip carriers.

Each of the three SIPs is available in three versions: 120, 150 and 200 nanosecond maximum access times. They operate from a single 5 volt power supply in a 0-70°C free-air temperature range.

For additional information contact Texas Instruments Semiconductor Division, (02)887-1122.

### Phoneme Speech Synthesizer

THE SSI 263A is a versatile, high-quality, phoneme-based speech synthesizer circuit contained in a single monolithic CMOS integrated circuit. It is designed to produce an audio output of unlimited vocabulary, music and sound effects at an extremely low data input rate.

Speech is synthesized by combining phonemes, the building blocks of speech, in an appropriate sequence. The SSI 263A contains five 8-bit registers that allow software control of speech rate, pitch, pitch movement rate, amplitude, articulation rate, vocal tract filter response,

and phoneme selection.

To produce different speech phonemes (sounds) the SSI 263A uses a model of the human vocal tract. Within the device this analogue tract is modelled with five cascaded programmable low pass filter sections. The filter sections are programmed internally by a digital controller. Either a glottal (pitch) or a pseudo-random noise source is used to excite the vocal tract, depending on whether a voiced or non-voiced phoneme is selected. During speech production the phonemes will typically last between 25 and 100 ms.

The SSI 263A has two general classes of attribute data: 'control' data (speech rate, filter frequency, phoneme articulation rate, phoneme duration, immediate inflection setting, and inflection movement rate) and 'target' data (phoneme selection, audio amplitude, and transitioned inflection). The SSI 263A responds immediately upon loading 'control' data; upon loading 'target' data the device will begin to move towards that target at the prescribed transition rates. This fully internal linear transitioning between target values, done in a

manner as is found in normal speech, is a key factor in reducing control data rate.

The synthesizer features a single low-power CMOS integrated circuit, a 5 volt supply, extremely low data rate, 8-bit bus compatible with selectable handshaking modes, non-dedicated speech, for text-to-speech programming, programmable and hard powerdown/reset mode, and switched-capacitor-filter technology.

For further information contact R & D Electronics Pty Ltd, PO Box 57, Crows Nest, NSW 2065. (02)439-5488.

### Solid aluminium capacitors

THE NEW Philips 124-series of solid aluminium capacitors has a test life of 5000 hours at 85°C.

These single-ended capacitors are potted in a square epoxy resin case with tightly controlled dimensions. This means that the

capacitors sit flush on a printed circuit board surface, enabling them to withstand severe shock and vibration. They are intended to replace tantalum capacitors in applications where high reliability is required.

The 124-series is for filtering, smoothing, coupling and decoupling in general and industrial applications — especially in automotive and mobile equipment.

Capacitance range is 0.1 to

68 µF, with a tolerance on nominal capacitance of ±20% (or ±10% on request).

For further information contact Philips Electronics Components and Materials, PO Box 50, Lane Cove, NSW.(02)427 0888.

# RITRONICS WHOLESALE

Incorporated in Victoria  
1st floor, 425 High St., NORTHCOTE 3070  
Phone 489 7099  
Telex AA38897  
MAIN WAREHOUSE  
56 Renver Rd., CLAYTON 3168  
Phone 543 2166

Att: Senior Purchasing Manager,

Please find listed below special wholesale pricing for a fraction of the range of products we import and are distributors for. We have approximately \$1,000,000 worth of wholesale stock off the shelf and we welcome all enquiries. Please feel free to ring myself (Rod Irving) or Peter Jones for competitive quotes on all your components and computer peripheral needs. New price lists and products will now be issued at regular intervals. Please note minimum account orders for these prices is \$50 per order.

Best regards,

*Rod Irving*  
Rod Irving

## CRYSTALS

Cat No.	Freq.	Can	1-99	100+
Y11000	1MHz	HC33	5.50	4.75
Y11005	2MHz	HC33	2.25	1.95
Y11008	2.4576MHz	HC33	2.25	1.95
Y11015	3.57954MHz	HC18	1.20	.90
Y11020	4.00MHz	HC18	1.30	1.20
Y11022	4.194304MHz	HC18	1.40	1.30
Y11025	4.75MHz	HC18	1.40	1.30
Y11026	4.9152MHz	HC18	1.40	1.30
Y11042	6.144MHz	HC18	1.40	1.30
Y11050	8.00MHz	HC18	1.40	1.30
Y11055	8.867238MHz	HC18	1.40	1.30
Y11070	12.00MHz	HC18	1.40	1.30
Y11072	14.318MHz	HC18	1.40	1.30
Y11080	16.00MHz	HC18	1.40	1.30
Y11085	18.432MHz	HC18	1.40	1.30
Y11090	20.00MHz	HC18	1.40	1.30

## POLYESTER 100V "GREENCAP" TYPE

Cat No.	Value	100V	1-99	100+
R15131	.001uF	100V	0.06	0.04
R15137	.0012uF		0.06	0.04
R15138	.0015uF		0.06	0.04
R15140	.0022uF		0.06	0.04
R15142	.0033uF		0.06	0.04
R15143	.0039uF		0.06	0.04
R15145	.0047uF		0.06	0.04
R15146	.0056uF		0.06	0.04
R15147	.0082uF		0.06	0.04
R15148	.01uF		0.07	0.05
R15150	.015uF		0.07	0.05
R15152	.022uF		0.07	0.05
R15154	.033uF		0.07	0.05
R15155	.039uF		0.07	0.05
R15156	.047uF		0.08	0.06
R15157	.056uF		0.08	0.06
R15158	.068uF		0.08	0.06
R15159	.082uF		0.08	0.07
R15160	.1uF		0.09	0.08
R15162	.15uF		0.11	0.10
R15164	.22uF		0.13	0.11
R15165	.27uF		0.14	0.13
R15172	.1uF		0.60	0.48
R15176	2.2uF	1.10	0.90	
R15178	3.3uF	1.50	1.20	

## DIODES

Cat No.	Desc	1-99	100-999	1000+
Z10135	IN4148	0.03	0.02	0.015
Z10105	IN4002	0.04	0.03	0.03
Z10107	IN4004	0.05	0.04	0.02
Z10110	IN4007	0.10	0.06	0.05
Z10115	IN5404	0.18	0.14	0.11
Z10119	IN5408	0.20	0.16	0.13

## TRANSISTOR

Cat No.	1-99	100+
2SJ49	3.50	3.30
2SK134	3.50	3.30

## MULTIMETERS

Cat No.	1-99	100+
YF1100	42.50	40.00

## ELECTROLYTICS

Cat No.	Desc	1-99	100+
R1415	1uF 63V PCB RB	0.05	0.04
R15461	10uF 16V PCB RB	0.05	0.04
R15462	10uF 25V PCB RB	0.05	0.04
R15482	22uF 25V PCB RB	0.06	0.05
R15521	47uF 16V PCB RB	0.07	0.06
R15522	47uF 25V PCB RB	0.08	0.07
R15581	1000uF 16V PCB RB	0.21	0.20
R15582	1000uF 25V PCB RB	0.28	0.25
R15591	2200uF 16V PCB RB	0.39	0.33
R15592	2200uF 25V PCB RB	0.55	0.50
R15904	2200uF 50V AXIAL	1.50	1.00

## RESISTORS

1/4 WATT E12 CARBON BULK  
PACKED \$4.00/1000  
TAPED AND BOXED \$4.75/1000  
\$4.75/1000 10K LOTS  
1/4 METAL FILM TAPED AND BOXED  
\$12.00/1000 \$10.00/1000/10K LOT

## MEMORY

Cat No.	10-99	100-999	1000+	10K+
4164-15P	\$3.50	\$2.95	\$2.75	\$2.50
41256	\$19.00	\$14.00	\$13.00	\$12.00
6116P-3	\$6.00	5.90	\$5.80	\$5.50
2716	\$4.90	\$4.50	\$4.25	\$4.00
27128	\$16.00	\$15.00	\$13.50	\$13.00
2532	\$7.50	\$6.50	\$6.40	\$6.30

## TRANSFORMERS

Cat No.	1-99	100+	
M12851	2851	2.00	1.75
M12155	2155	4.00	3.50
M16672	6672	5.10	4.75

## MONITORS

Cat No.	1-3	4+	
X14500	Riltron 1 Green	\$100.00	\$95.00
X14502	Riltron 1 Amber	\$105.00	\$100.00
X14506	Riltron 2 Amber	\$125.00	\$122.00
X14510	Riltron 3 Amber	\$129.00	\$124.00

## 75OHM COAX CABLE

Cat No.	100M	500M	1000M	
W11222	3C2V	18.00	17.00	16.00
W11224	5C2V	21.00	20.00	19.00

## 100M ROLLS

Cat No.	100M	500M	1000M
W11222	6.2dB	(Approx)	
W11224	3.9dB	(Approx)	

## COMPUTER CONNECTORS

Cat No.	1-99	100+	
P10900	DB25 Plug	1.30	1.20
P10901	DB25 Socket	1.40	1.30
P12210	Centronics Solder	3.50	3.15
P12200	Centronics Crimp	4.00	3.75

## NICADS

Cat No.	1-99	100+	
S15021	C 1.8AH	3.25	2.90
S15022	D 4.0AH	5.90	5.50

## HORN SPEAKERS

Cat No.	1-99	100+	
C12010	5" Plastic 8W Max	4.80	4.70
C12015	5" Metal 8W Max	4.70	4.30

## METAL BOXES

Cat No.	1-99	100+
H10442	2.50	2.00

## SOLDERING IRON STANDS

Cat No.	1-99	100+
T11302	3.25	3.00

## VERBATIM DATA LIFE DISKETTES

SS/DD	MD525-01	1-99	100+	1000+
DS/DD	MD550-01	2.50	2.20	2.00
		3.30	3.00	2.60

## FANS

Cat No.	1-99	100+	
240V	4 1/2"	10.50	10.00
240V	3 1/2"	10.50	10.00
115V	4 1/2"	10.50	10.00
115V	3 1/2"	10.50	10.00

## RG CAN TYPE WITH LUGS

Cat No.	Value	1-99	100+
R164585	8000uF 75V	6.00	5.80
R16587	10,000uF	7.00	6.50

## IDC CONNECTORS

Cat No.	Value	1-99	100+
P12114	14 Pin Dip Plug	0.60	0.50
P12116	16 Pin Dip Plug	0.65	0.55

## GREY FLAT RIBBON CABLE

Cat No.	No Cond	Per Mtr	1-3	4+	10+
W12616	16 Way	1.29	19.75	18.50	16.50
W12625	25 Way	1.40	29.50	27.50	23.50
W12626	26 Way	1.60	31.00	29.00	25.00
W12634	34 Way	1.80	40.00	38.00	34.00
W12640	40 Way	2.20	50.00	47.50	42.50
W12650	50 Way	2.75	59.00	57.50	52.50

## EX STOCK

LARGER QUANTITIES NEGOTIABLE

## PANEL METERS

Cat No.	Value	1-99	100+
Q10500	MU45 0-1mA	5.50	5.25
Q10502	MU45 50 0-50uA	5.50	5.25
Q10504	MU45 0-100uA	5.50	5.25
Q10505	MU45 0-50uA	5.50	5.25
Q10510	MU45 0-5A	5.50	5.25
Q10518	MU45 0-1A	5.50	5.25
Q10520	MU45 0-20V	5.50	5.25

## BRIDGES

Cat No.	Value	1-99	100+
6A 400V	1.00	0.80	0.75

## RCA INSULATING SOCKETS

Cat No.	Value	1-99	100+
P10232	2 Way	0.25	0.21
P10234	4 Way	0.45	0.40
P10236	6 Way	0.75	0.60

## RCA CHASSIS MOUNT METAL

CAT NO.	1-99	100+
P10231	0.16	0.13

## MITSUBISHI DISK DRIVE

Cat No.	Value	1-99	100+
4851	5 1/4"	\$180.00	\$170.00
4853	5 1/4"	\$220.00	\$205.00
4854	5 1/4"	\$280.00	\$260.00
2896	8"	\$450.00	\$420.00

All prices plus 20% sales tax where applicable.  
Minimum wholesale purchase \$25

FAIRCHILD DISTRIBUTORS, WELLER DISTRIBUTORS  
Direct Importers of Memory IC's, Disk Drives, Resistors,  
Capacitors, Telephone Cable, Joysticks, Burglar Alarm  
Equipment, Monitors, T.V. Accessories, Coax Cable,  
Crystals, Audio Leads and Hardware. In fact most  
electronic products. Resellers, OEM's, Bulk Users, please  
write for 100 page Computer Price List.  
Minimum P/Pack \$3.00  
Minimum Account P/Pack \$5.00  
Comet Road Freight is extra, for items that are bulky and/or  
over 10Kg.  
Bankcard, Mastercard, Visacard Welcome

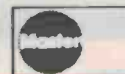

**ArtLit  
Lighting  
Equipment**



# HELICOPTERS

<b>4 HEAD</b>	<b>\$179.90</b>
<b>6 HEAD</b>	<b>\$219.90</b>
<b>8 HEAD</b>	<b>\$269.90</b>

**(COMPLETE WITH LAMPS)**





# Hi-TECH LIGHT AND SOUND

**HIRE \* SALES \* SERVICE**

63 Hardgrave Road, West End 4101  
 Postal Address: P.O. Box 377, West End  
**Phone: (07) 44 4971**

**WRITE  
 FOR FREE  
 CATALOGUE**

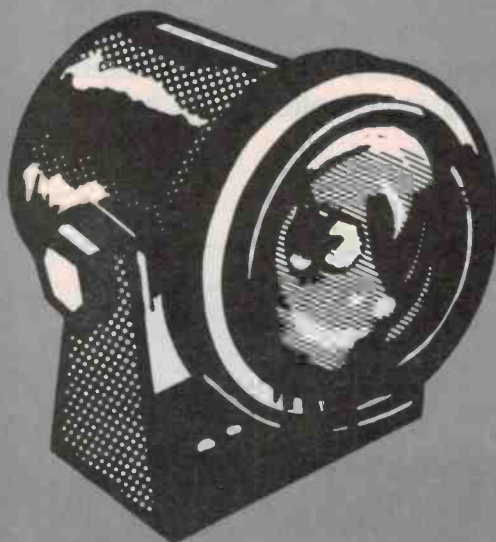

## PINSPOTS

**PAR36                      \$29.90**

**PAR46                      \$39.90**

**(COMPLETE WITH LAMP)**

**Mail Orders  
 + Installations  
 + Other Info**

**CREDIT CARDS**  
 Bankcard, M/Card, AGC Credit Line



**CLUB INSTALLATIONS**  
 Excellent service through Australia.

**INSTALLERS**  
 Write to us for attractive Trade  
 Terms.

**MAIL ORDERS (AUST)**

Add packing & post (P&P) as follows  
 (Aust. only) **MINIMUM MAIL ORDER \$25**

Goods \$25-\$49	P&P\$3.50
Goods \$50-\$99	P&P\$5.00
Goods \$100-\$149	P&P\$7.50
Goods \$150-\$199	P&P\$10.00

Goods \$200 + Add 5% to Order value  
 or otherwise by individual quotation.

Send to: **HI-TECH LIGHT & SOUND**  
 63 Hardgrave Rd.  
 West End Q. 4101.

# STEREO ENHANCER

The best thing about stereo is that it sounds good! The greatest stereo hi-fi system loses its magnificence if the effect is so narrow you can't hear it. This project lets you cheat on being cheated and creates an 'enhanced stereo effect' with a small unit which attaches to your amp.

Robert Irwin



WHEN IS A STEREO not a stereo? Answer: When you try to fit your 60 cubic foot, six way monitors into your new, one bedroom flatette and find that the only place you can put them is side by side where they double as a dining table. Not the ideal situation to get that wonderful stereo separation that causes steam trains to thunder in one side of your living room, roar across the coffee table and exit through the window on the opposite side.

The ETI-1405 is designed to 'widen' out the stereo image from your amp and allow you to maintain that stereo feel even when you have to put your speakers close together.

The unit is designed to plug into the cassette input and output on the back of a standard stereo amp and can be switched in and out of circuit by using the TAPE/SOURCE switch. An alternate set of cassette in/out terminals is provided on the back of the enhancer to plug your deck into.

## Design details

The idea behind the circuit is very simple and has been used in small portable stereo tape decks for quite a while. Figure 1 shows a block diagram of the circuit of the enhancer. The principle used is basically to obtain the difference between the left and right channel and then to subtract this from the original left and right channel signals. This is explained more fully in the "How it Works" section.

The end result is to obtain a 'super stereo' signal which has components for the left channel of  $L+A(L-R)$  and for the right channel of  $R+A(R-L)$  where  $R$  is the original right channel signal,  $L$  is the original left channel signal and  $A$  is a proportion between 0 and 1 which is set by the level control.

One unusual feature of the design came about in the metering provided. It was firstly thought that a measure of the signal levels at the output, along the lines of VU metering, should be provided.

After a quick rethink though, it was decided that this wouldn't really be of much

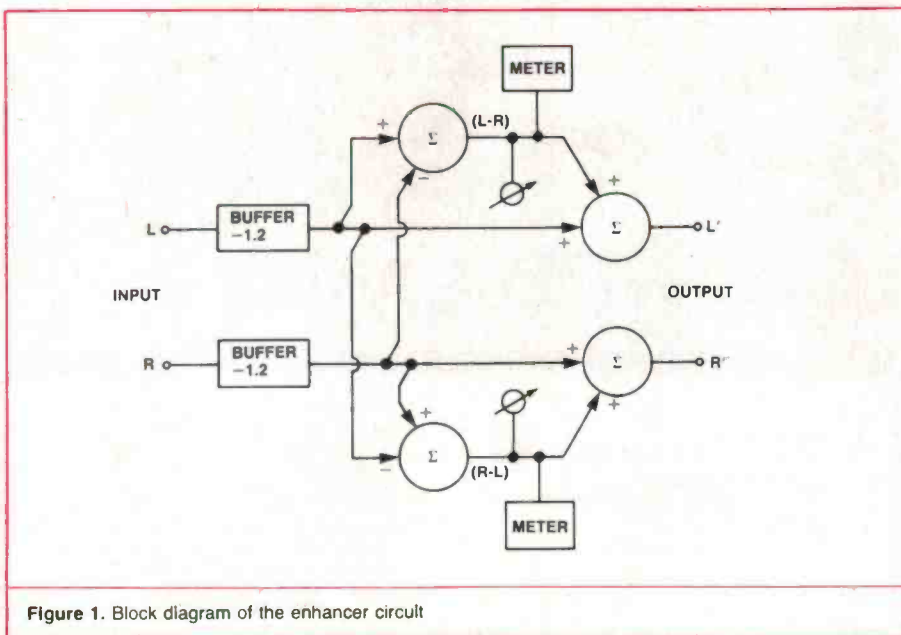
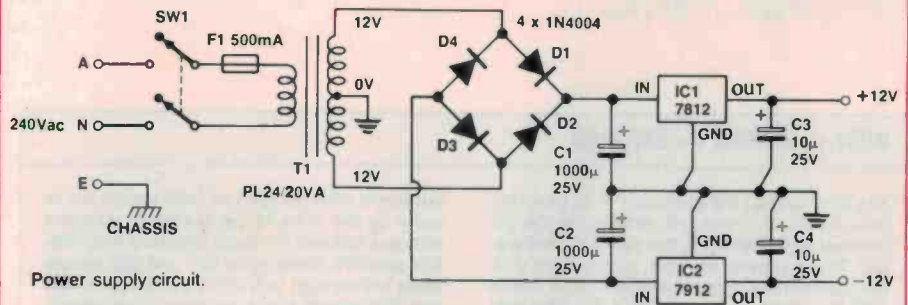

Figure 1. Block diagram of the enhancer circuit



benefit to anyone as the signal levels here weren't really interesting. A much more relevant meter would be one that in some way indicated the amount of enhancement taking place. LED level meters were, therefore, placed at the output of the level control pot in the difference amp section of each channel. This gave a direct and dynamic representation of the enhancement. To add to this, the displays for each channel were mounted back to back giving a centre-zero, bar graph display which visually shows the widening of the stereo image.

### Construction

It is best to begin construction with the case. The prototype was mounted in a Horwood instrument case. If you are using an

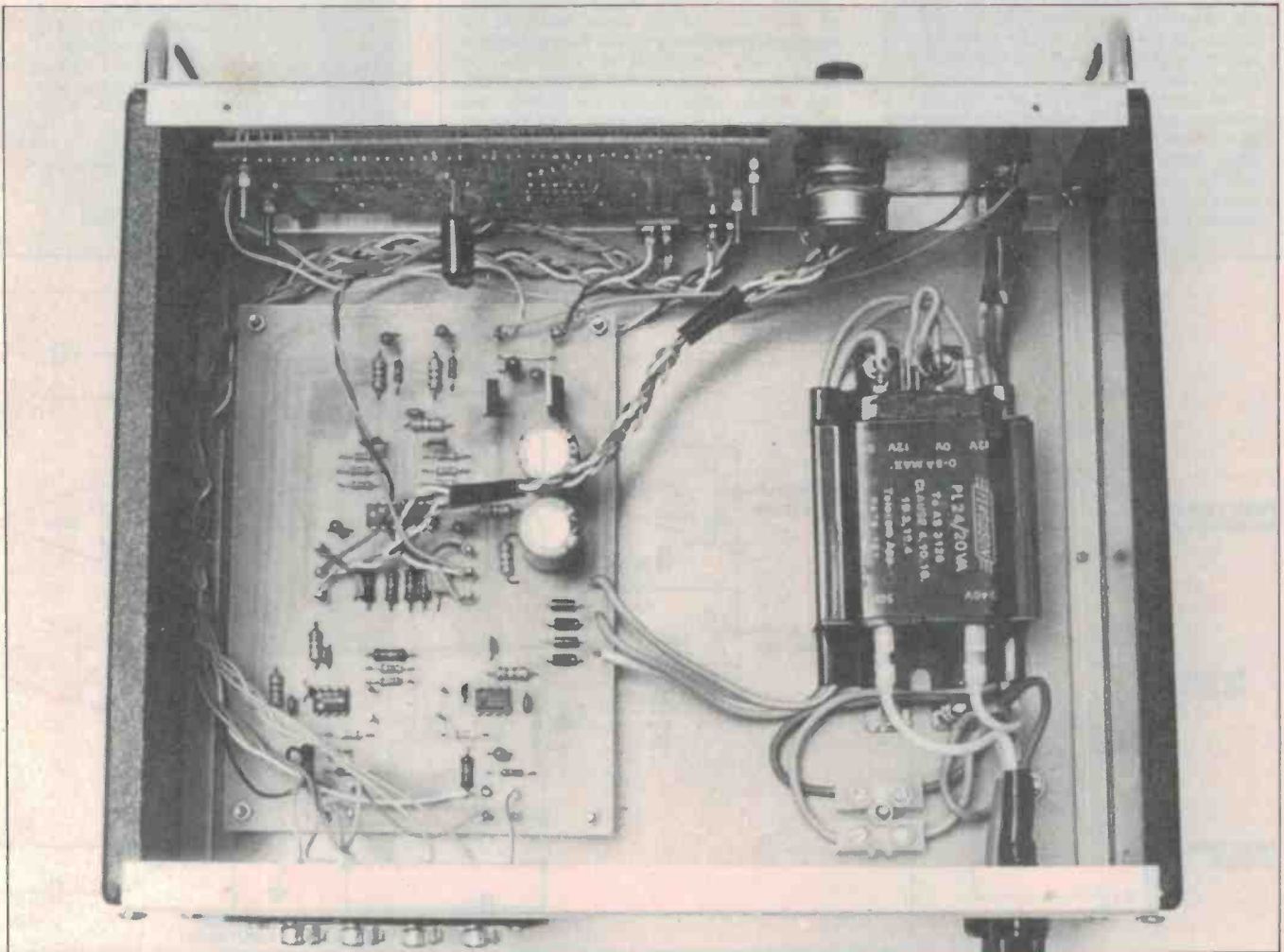
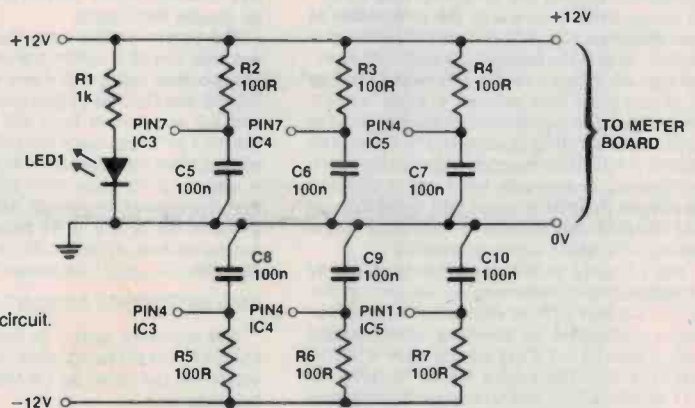

## HOW IT WORKS — ETI-1405

The idea behind the enhancer is to generate two signals, R-L and L-R, where L is the left channel signal and R is the right channel signal. These signals are then mixed back with the appropriate original signals (R is mixed with R-L and L is mixed with L-R). The final composite signals are R+a(R-L) and L+a(L-R) respectively where a is the proportion of the difference signal. If a is zero then the output will be just the original left and right channel signals. When a is one, the outputs will be 2L-R and 2R-L. This creates a 'super stereo' image because signals which are the same in both channels (that is centered in the stereo field) will be left unchanged but signals which are panned to one side will be of a different amplitude in each channel and the enhancer will increase this difference and thus give a feeling of a wider stereo separation.

The circuitry of the enhancer is relatively straightforward. Referring to the circuit diagram, IC3 and IC4 are NE5534 low noise op-amps configured as inverting buffer stages with a gain of -1.2 set by the ratio R12/R10 and R13/R11. The inputs are ac coupled via C11 and C12. C13 and C14 provide unity gain compensation for the NE5534s. The difference signals are created by IC5a and IC5b which are configured as unity gain differential amplifiers. The output of IC5a is the L-R signal and the output of IC5b is the R-L signal. C15 and C16 prevent any high frequency instabilities.

The outputs from the diff amps are fed to a dual pot, RV1, which controls the amount of difference signal being fed to the final summing amplifier stages formed by IC5c and IC5d and associated resistors. This stage sums the original and difference signals. The summing amps are virtual earth, inverting

summers with the gain of both inputs set to unity by the ratio of the feedback resistors R26 and R27 and the input resistors R22, R23, R24 and R25. Once again C19 and C20 ensure there are no high frequency instabilities. R28 and R29 supply some isolation from capacitive loading on the output and C21 and C22 ac couple the output.

The power supply circuitry is fairly standard with the 24 V centre tap secondary of the transformer being full wave rectified by D1, D2, D3 and D4. The output is smoothed by C1 and C2 and this is then fed to LM7812 and LM7912 12 V regulator ICs (IC1 and IC2). The output from the regulators provides accurate + and - 12 V supply rails. C3 and C4 ensure that the regulators remain stable. R2, 3, 4, 5, 6, 7 and C5, 6, 7, 8, 9, 10 provide decoupling for the op-amp supplies. R1 limits the current through the LED1, the power on indicator.

## THE METERING CIRCUIT

The metering circuit is based around the LM3914 LED driver IC. Both the left and right meter are the same so I will only refer to the left channel.

The input to the meter is ac coupled via C24 and R32 and fed to the input pin (5) of the LM3914. D5 limits the reverse voltage swing to -0.6 volts and C26 slows down the response time of the meter. Pin 7 of the LM3914 is internally referenced to 1.2 V. This is divided down to about 0.2 V by R36 and R34. This voltage is then fed to pin 6 of the IC and sets the full scale of the meter to 0.2 V. If less sensitivity is required then R34 can be increased. The sum of R34 and R36 should be kept to less than about 1 K otherwise the brightness of the display may decrease.

## PARTS LIST — ETI-1405

<b>Resistors</b> .....	all 1/4 W, 5%
R1.....	1k
R2, 3, 4, 5, 6, 7,	
28, 29, 34, 35.....	100R
R8, 9, 30, 31,	
32, 33.....	100k
R10, 11, 14, 15,	
16, 17, 18, 19,	
20, 21, 22, 23,	
24, 25, 26, 27.....	10k
R12, 13.....	12k
R36, 37.....	560R
RV1.....	100k lin. dual ganged
<b>Capacitors</b>	
C1, 2.....	1000µ 25 V RB electro.
C3, 4, 11, 12,	
17, 18, 21, 22,	
24, 25.....	10µ 25 V electro.
C5, 6, 7, 8, 9,	
10.....	100n ceramic bypass
C13, 14.....	22p ceramic
C15, 16, 19, 20.....	150p ceramic
C23, 28.....	2µ2 25 V RB electro.
C26, 27.....	220n greencap
<b>Semiconductors</b>	
IC1.....	LM7812 pos. regulator
IC2.....	LM7912 neg. regulator
IC3, IC4.....	NE5534 op-amp
IC5.....	TL074 quad op-amp
IC6, IC7.....	LM3914 LED driver
D1, 2, 3, 4.....	1N4004 rectifier diodes
D5, 6.....	1N914 small signal diode
LED1.....	5mm red LED
	two 10 LED arrays
<b>Miscellaneous</b>	
SW1, 2, 3.....	DPDT toggle
T1.....	Transformer Ferg. type PL24/20VA or similar

ETI-1405 and 1405b pc boards; Horwood case type 84/10/V; two four way RCA socket arrays; Scotchcal front and back labels; mains flex and plug; mains grommet and clamp; four way terminal block; 2AG fuse holder and 500 mA fuse; hookup wire; nuts and bolts; knob for rotary pot; four rubber feet.

**Price estimate: \$70-\$80**

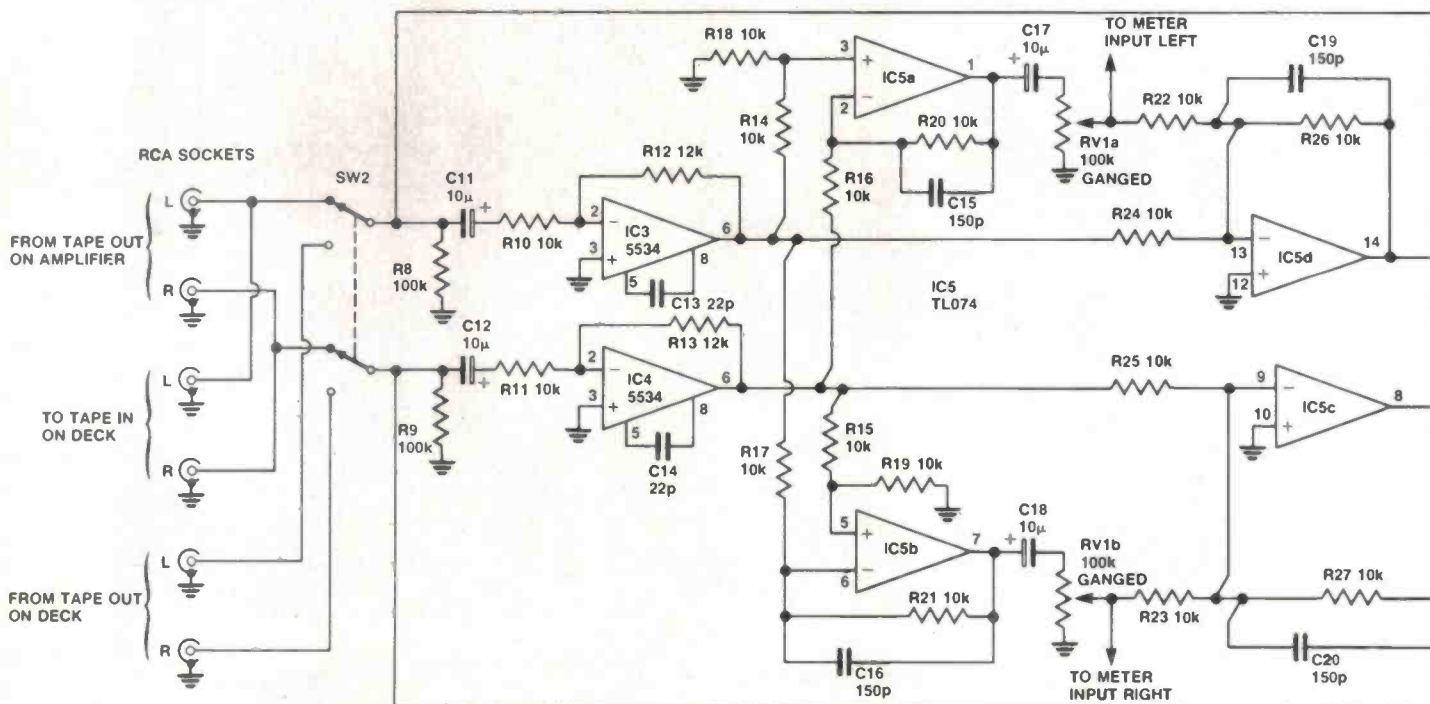

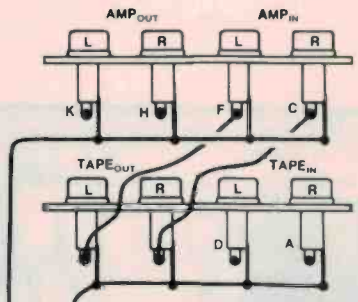
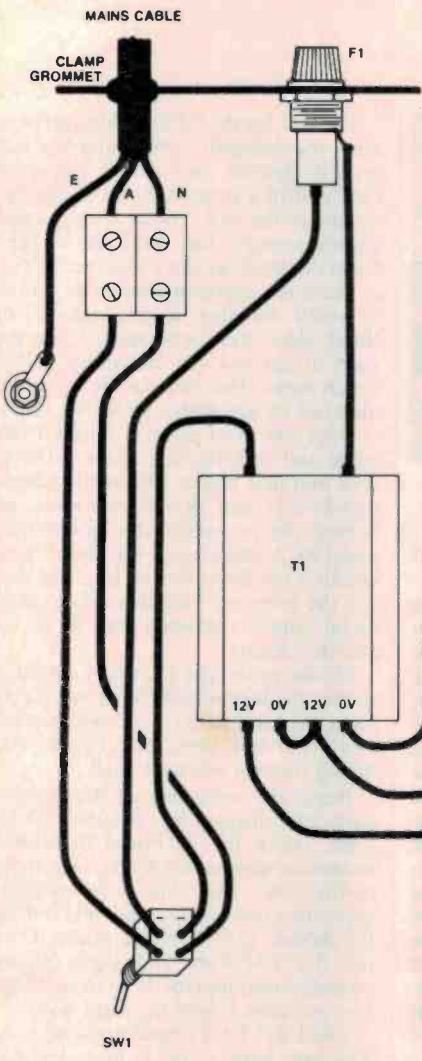

For a guide to buying components and kits see **SHOP AROUND** this issue.

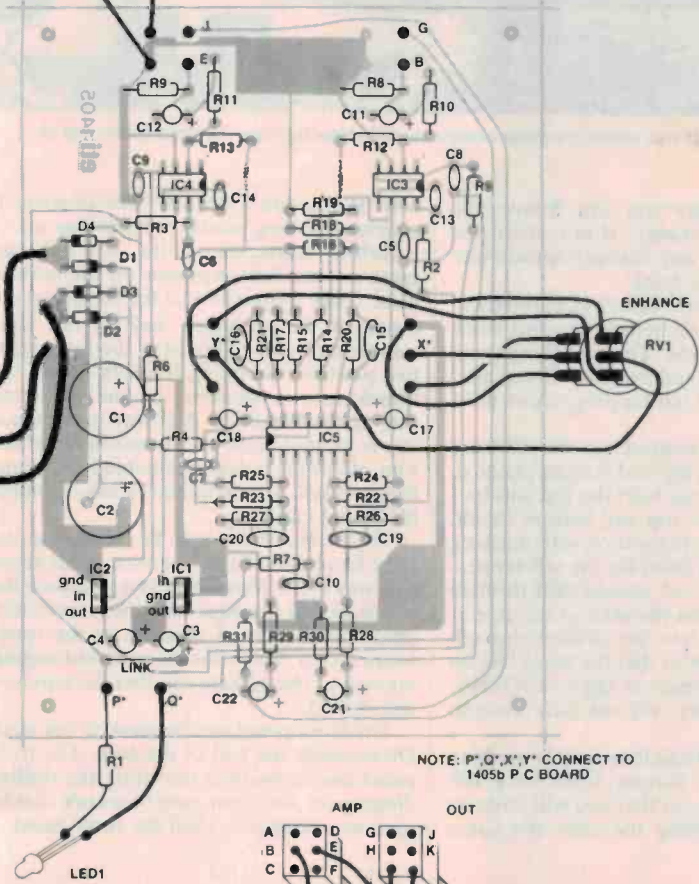

NOTE: P\*, Q\*, X\*, Y\* CONNECT TO 1405b P C BOARD

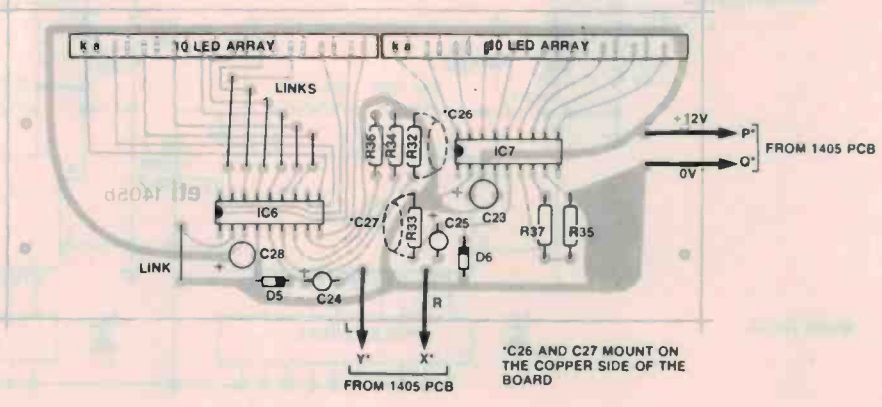
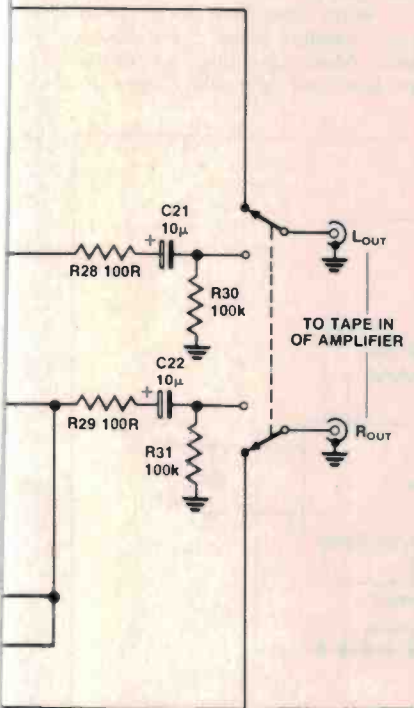
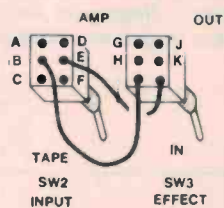

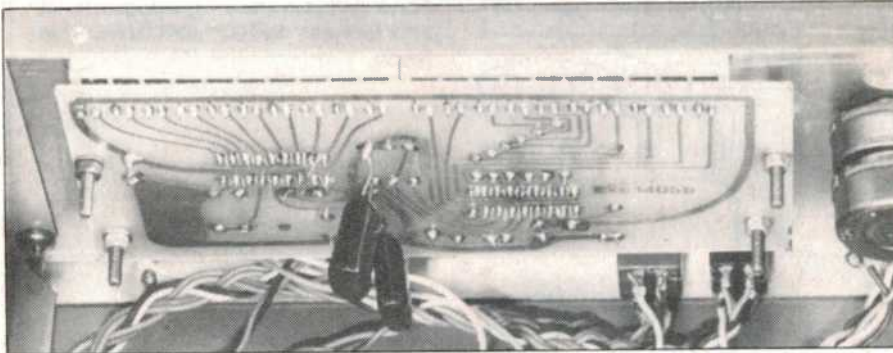

The back of the front! This shows the meter board mounting. Note the caps mounted on the rear of the board.

identical case then you can follow the mounting details exactly. If not, then you will have to make any changes appropriate to the case you are using.

The Horwood case comes assembled except that the top and bottom are only stuck on with masking tape. The first thing to do is to take the top and bottom off and find the little packet of self-tapping screws lurking inside.

The next step is to mark out the positions of the holes on the top and bottom plates so that these screws can hold the top and bottom plates on. The top and bottom should then be stuck back in position with masking tape and the small holes for the self-tappers drilled. Note that you should drill through the mounting lips on the sides of the case at the same time as you are drilling through the top and bottom so that the holes line up accurately. Don't use too big a drill otherwise the self-tapper will not have enough metal to grip.

Take the top off and then, with a marking pen, mark the top, bottom, front, back, left side, right side etc, so that you will have no trouble re-assembling the case the same

way. If you don't you will have all sorts of problems getting all the holes to line up.

Before disassembling the box you can mark out the hole positions on the picture of the inside of the prototype and lay out your transformer and pc board in the same relative positions. Looking from the front, the transformer is mounted on the left hand side of the box about half way back. Once this is located mark out the positions of the four mounting holes. Just behind the transformer mark a hole for the mains terminal block and earth lug.

The pc board can now be located on the right hand side of the box once again about half way back. Make sure you orientate the board so that the edge with the transformer input connections is adjacent to the transformer itself. Mark out the pc board mounting holes. The bottom can then be removed and drilled.

The front panel can be marked out next. Disassemble the rest of the case. The front panel can be marked out using the drilling diagram or the front panel artwork can be used as a template. Drill the front panel.

The slot for the LED arrays can be made using the old drill, nibble and file method (or fill, dribble and nile if you prefer!). Firstly, drill a series of holes along the centre line of the slot. The drill used should be slightly smaller than the width of the slot. Keep the holes as close together as you can so there is a minimal amount of metal left. A small nibbling tool (hacksaw blade, chisel, sidecutters or whatever!) can then be used to cut out the remaining metal between holes. The slot can then be carefully filed out to size with a small flat file.

Once the front panel is finished you can mark and drill the rear panel. The mains cord and fuse holder sit directly behind the transformer and the RCA sockets mount behind the pc board. To mount the rear panel RCA sockets you will have to position and drill the holes for the lugs and then file out the holes so that there is no metal to metal contact between the RCA sockets and the chassis.

On the prototype I actually cut out a slot so that the lugs would have good clearance. Once the back panel is finished you can put away your drill press and get out your soldering iron for the next step.

Begin the mounting of the components with the display pc board (ETI-1405b). First, check the pc board thoroughly for broken or shorted tracks. Locate and solder in the seven wire links. The resistors and capacitors can be mounted next followed by the diodes. It is advisable to use IC sockets for the LM3914s and these should be mounted next and the ICs put in. Make sure you get them round the right way.

The LED arrays should now be mounted. You may have a little trouble getting them in at first but just persevere. Once you get them in the holes then push them down until they are standing about 5 mm above the pc board. Make sure they are sitting straight and level and then solder them in.

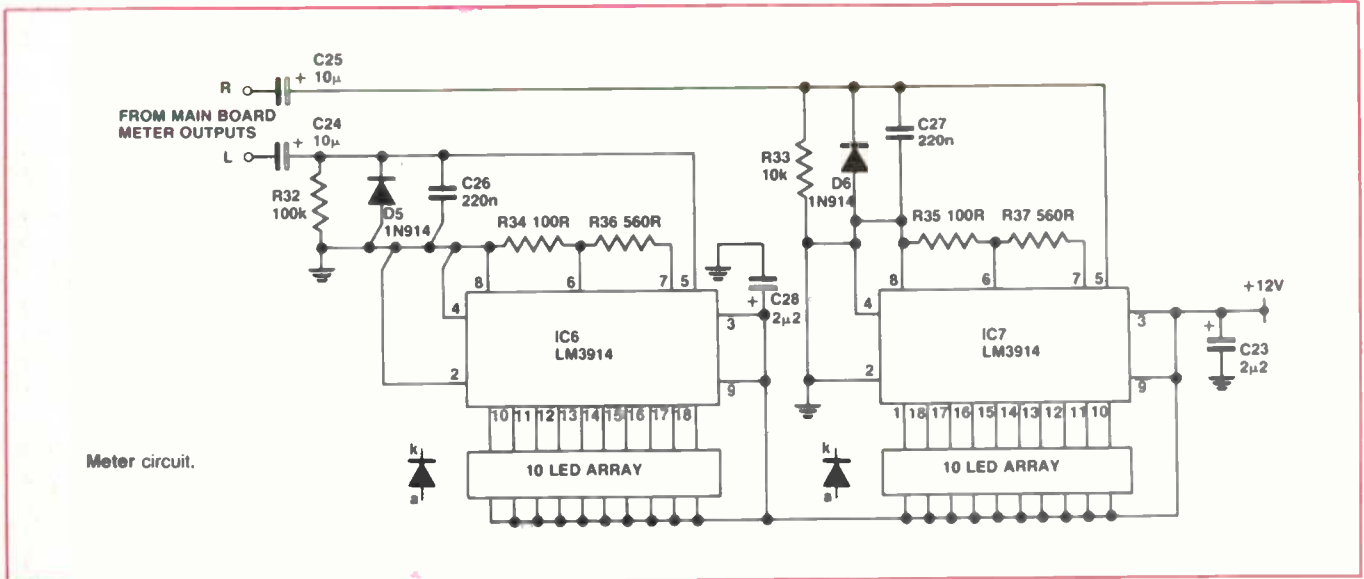

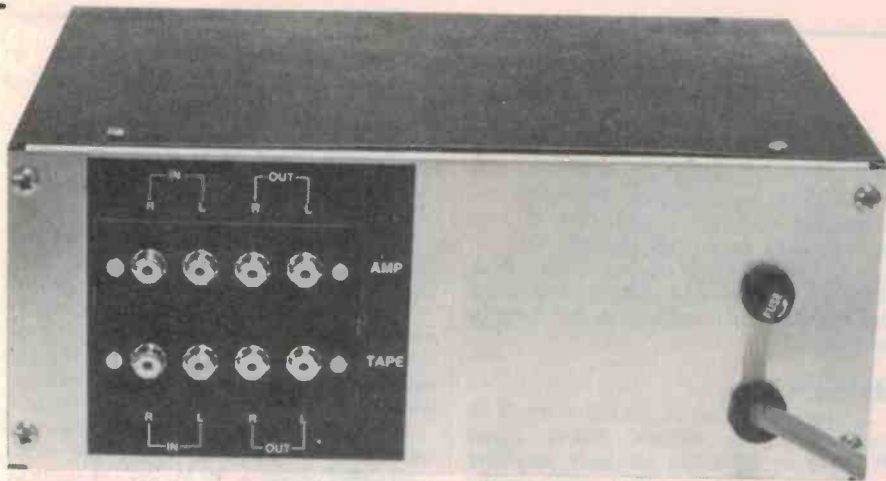

View of the rear panel showing the two RCA arrays.

Take care that you get the displays the right way round as desoldering them can be a real pain in the enhancer.

The two capacitors which mount on the copper side of the board can now be soldered on. The only thing left to be done on this board is to solder about 100 mm lengths of hookup wire to the input and power supply pads.

Turn your attention now to the main pc board. This should be constructed in a similar way to the display board. Resistors and caps first followed by diodes and ICs. Once again take care to get all the polarized components the right way round, especially the big electrolytic caps on the power supply.

Do not use IC sockets with the ICs on this board as the stray resistances and capacitances can degrade the performance of the circuit. Solder pegs should be used on all the flying lead connections on this board to make the wiring up easier.

The next step in construction is to attach the Scotchcal artwork to the front panel. Firstly drill small pilot holes in the centres of all the holes and at the end points of the slot on the Scotchcal. Peel off the backing paper on the Scotchcal and thoroughly wet the back of the Scotchcal and the front panel (the water will allow you to easily peel off the label again if you don't line it up correctly the first time).

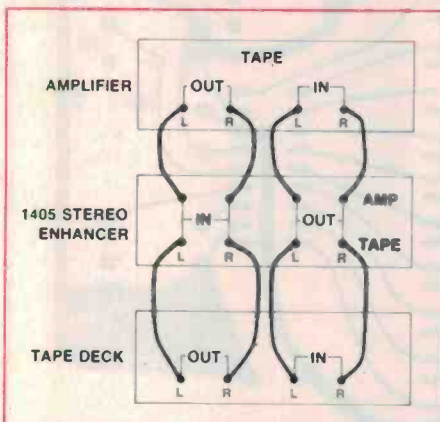

Figure 2. Connecting the stereo enhancer to your amp and tape deck.

Line up the holes on the Scotchcal with the holes drilled in the front panel and then press the Scotchcal firmly in place. Gently rub out the excess water with a soft cloth and set the front panel aside to thoroughly dry. The same treatment can be given to the Scotchcal back panel.

When both the panels are completely dry the holes can be carefully cut out and trimmed using a very sharp knife or scalpel. Try not to tear the Scotchcal or cut off a finger when doing this.

Before re-assembling the case you should attach the mounting bolts for the display board. Sit the display board on the back of the front panel so that the LED displays fit through their slot. Mark out the positions of the mounting holes. Four 20 mm long 6BA flat headed bolts should then be glued to the back of the front panel with Araldite or something similar. Allow the glue to completely harden. The case should now be re-assembled with the exception of the lid.

Now comes the wiring up. Start with the mains wiring. Firstly, securely mount the transformer, terminal block and fuse holder. Mount a length of mains flex using either a clamp type mains grommet or a grommet and separate mains clamp.

Carefully follow the wiring diagram and wire up the mains switch, fuse holder and primary of the transformer with heavy duty hookup wire. Make sure that you insulate any exposed joins or terminals with heat-shrink or insulating tape. REMEMBER: mains voltages are lethal so double and triple check your wiring and make sure that you can't accidentally touch any exposed terminals. The mains switch can now be securely mounted to the front panel.

Next mount the display board. The board should be mounted so that the LED arrays protrude about 2 mm through the front panel. The main board can be mounted next using 12 mm spacers.

Using the wiring diagram, wire the secondary of the transformer to the main board. The flying leads from the display board can also be attached to the main board at the appropriate points. The power indicator LED can then be mounted and wired up. The two RCA socket arrays should then be mounted on the rear panel. The input and output wiring, including the

# WANTED

## TRAINING TECHNICIAN

(Sydney)

Interesting and varied position in fast growing, modern electronic and radio communications company.

We need an intelligent and ambitious young man.

Apply in writing.

**EMONRA**  
electronics pty ltd

P.O. Box K21, Haymarket,  
NSW 2000

Send us a sample of your parts like these for a quote. We'll meet your specs, reduce your costs.

Swann Electronics are a large supplier and user of small metal parts. We can quickly supply volume users with standard components or we can fabricate custom designs with minimal tooling.



Available from:  
**SWANN ELECTRONICS  
INTERNATIONAL**  
PTY. LTD.  
Melbourne (03) 544 3033  
Sydney (02) 807 1944  
N.Z. (9) 444 3620

# Project 1405

two switches, can then be done.

Finally, 250 mm lengths of hookup wire can be attached to the dual 'enhancement' pot and then attached to the pc board. The pot can then be mounted on the front panel and the knob attached.

## Testing and setting up

The only real way of testing the enhancer is to turn it on so, with nothing attached to the input or output, plug it into the mains and switch on for a few seconds. The power LED should light and all the display LEDs should remain off. Other than that nothing should happen. If anything else happens (smoke, fire, brimstone, nasty hissing or popping noises, etc) switch off immediately and check everything.

If all is OK then switch on again and try rotating the enhancement pot. The display LEDs should stay off. If any come on then

there is probably a fault in the pc board. If all is well then you turn can off, screw the lid on and hook the enhancer up to your stereo system as per the diagram. The enhancer takes the place of your cassette deck in the system and your cassette deck plugs into the additional sockets on the back of the enhancer.

## Using it

To use the enhancer set the controls of your stereo as follows. Select either PHONO or TUNER on your amplifier source switch. Set the effect switch on the enhancer to IN and the input switch to AMP.

Now all you need do is select TAPE on the TAPE/SOURCE button on your amp to cut the effect in. With the TAPE/SOURCE button on SOURCE the effect will be bypassed. To play a cassette through the en-

hancer once again select TAPE on the amp and switch the input switch on the enhancer to TAPE.

To play a cassette without the effect just switch the effect switch on the enhancer to OUT. Don't worry, you'll get the hang of it!

Turning the enhancement control clockwise increases the effect and this will be echoed in the LED display. As the enhancement is increased the bargraph should get wider and wider from the centre outwards.

It should be noted that the amount of 'stereeness' is fairly subjective and some tracks may appear to be affected more than others. At first the effect may sound a little false but it is a bit like 3D pictures in that you must let your brain deceive your senses. When you get over trying to convince yourself that your speakers aren't far enough apart to get good stereo then the effect will be more convincing. ●

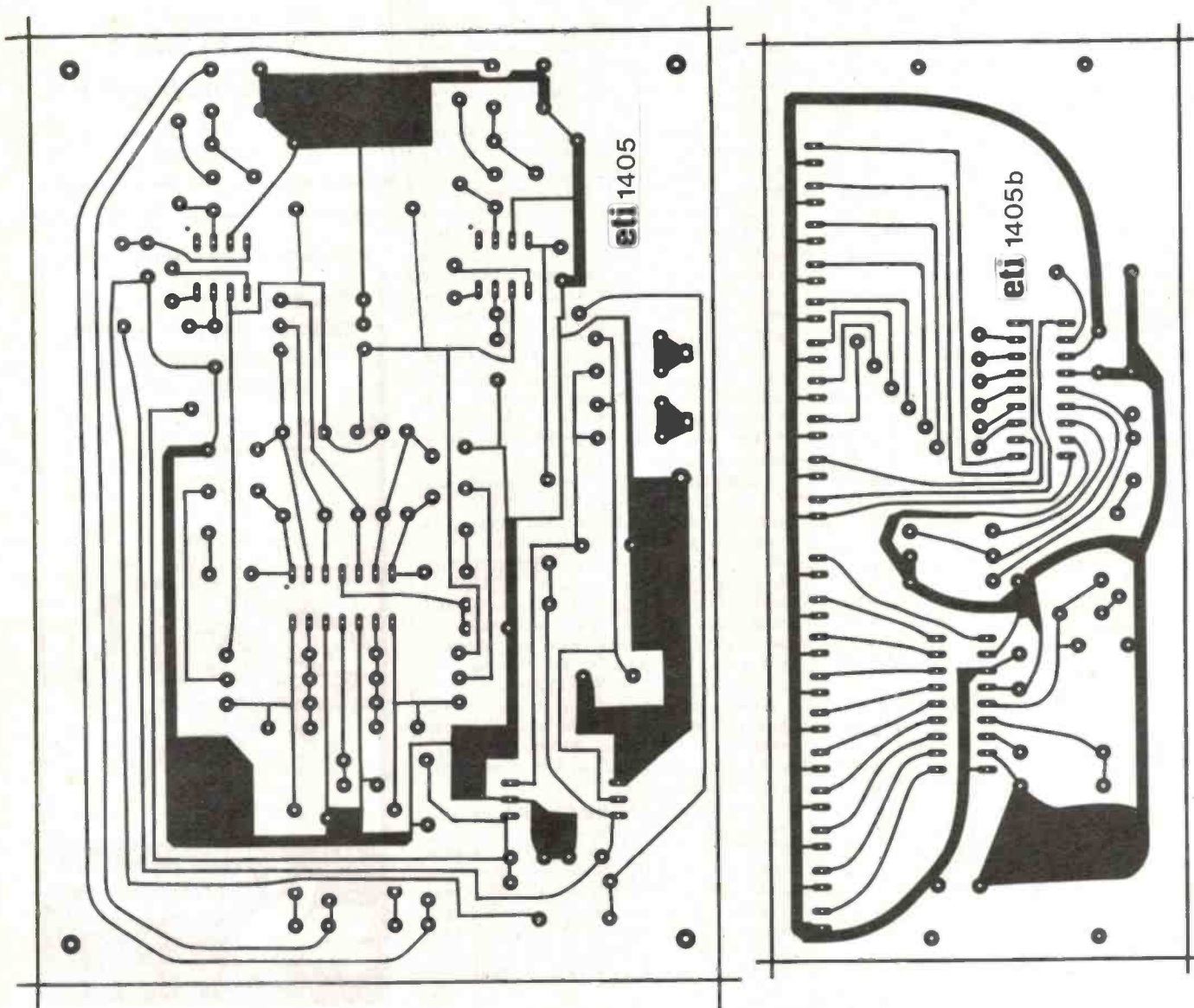





# DIGITAL LUXMETER

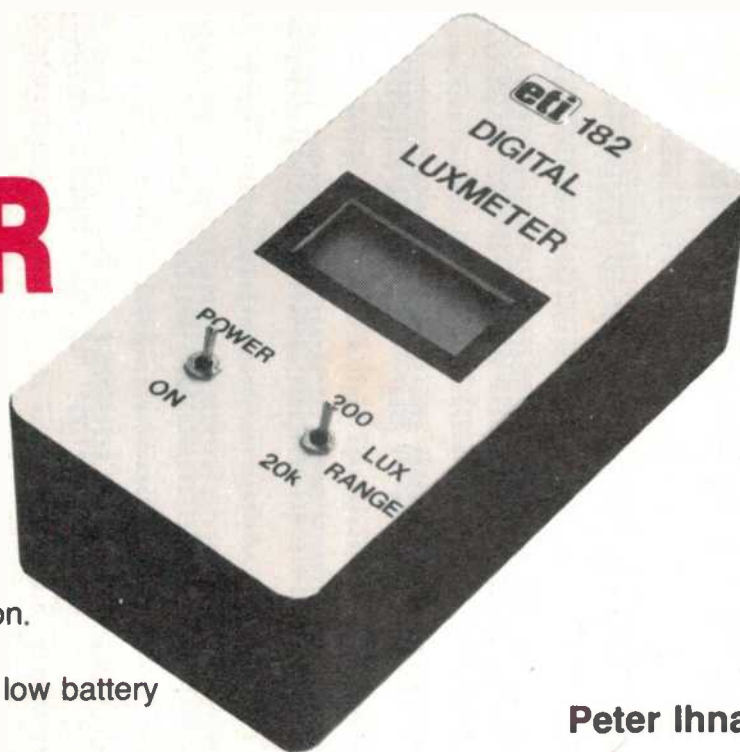

Peter Ihnat

This instrument is a portable, battery operated device for measuring illumination. It covers light levels from below 1 lux up to 20k lux in two ranges and includes low battery indication.

ETI, IN THE PAST, has described many instruments for measuring just about anything from heart rate through to passion (yes, we published a passion meter once long ago !!!). One quantity however which seems to have missed out is *light*.

In the last twelve months we described two devices which measure light, but not in absolute terms. They were both darkroom exposure (or light) meters. These 'measure' the amount of light in a particular area of the image produced by an enlarger by comparing the intensity with that of a value obtained when a test print was made. Unfortunately, outside the darkroom this technique is of limited use.

The current project can measure light in absolute terms, just as we measure current in amps and frequency in Hertz. This results

in a versatile unit for anyone having anything to do with lighting systems. Some examples include, photographers, electricians who fit lights into classrooms, offices and factories or even the home video nut who insists on video taping under very low light levels . . . the list is endless.

Why do these people need to know the level of illumination? The answer is rather obvious in the case of photographers, movie and video camera operators. They need to ensure that the illumination of a scene or subject is sufficient to produce images with the maximum amount of detail. Poor lighting setups can only produce poor images.

In the case of classroom, factory and office lighting, there are recommended illumination levels to suit the type of work performed in each area. To give the reader an idea of illumination available from some common sources and some recommended levels, refer to Table 1. As you may notice, the eye (like the ear) has a wide dynamic range.

One problem in the past with designing a luxmeter was that a suitable sensor was not available in this country. Only fairly recently has one of the few photodiodes which covers more than the red and infra-red regions of the spectrum become readily available in Australia. Ladies and gentlemen . . . introducing the BPW21 photodiode.

Figure 1 shows some of the photodiode's characteristics. Its peak spectral response is around 555 nm, corresponding to yellow/green light. Its spectral range is 350 to 775 nm which almost matches that of the human eye (see dotted line labelled as  $V_\lambda$ ). For many applications this is quite adequate and

makes it ideal for monitoring daylight or artificial light. One more important feature is that its short circuit current versus illumination is highly linear over a wide range (0.01 to 100k Lux) . . . truly a remarkable sensor.

Figure 2 shows the operation of the luxmeter in block diagram form. The BPW21 is connected in the standard way (reverse biased and into a short circuit) to produce a current in direct proportion to illumination. This is converted to a voltage which is fed into a voltmeter and displayed in digital form. Normally, a circuit such as this would be rather complex but the availability of the ICL7106 digital voltmeter IC reduces the parts count dramatically. Those interested in the digital voltmeter circuitry can refer to two previous ETI articles — ICL7106 data sheet ETI October 1977 and project 161 ETI August 1982.

## Construction

Construction should present few problems if the recommended pc board is used. The layout is not critical and other forms of construction such as Vero-board, may be employed. Use of the recommended board does result in a very compact unit and if correctly assembled will help to ensure that everything works first go.

Firstly, inspect the pc board for broken tracks or shorts — check carefully in the areas where tracks pass between IC pins. If all is OK, start by fitting the three wire links. Note that one link has a 90° bend in it.

Next, mount the resistors, capacitors and trimpots in that order — it may be necessary to bend the leads of capacitor C6 inwards slightly to fit in its correct position. The 40- ▶

Description	Illumination
Full moon	0.4
Candle flame at 1 m	1
Highways	20-30
Living rooms and offices	300-400
Shops, workshops and classrooms	500
Area for fitting components to pc board	800
Precision engineering workshops, drawing offices	1000
High precision work eg. repairing watches	3000
Bright summer day	100 000

Table 1. Illumination levels in lux.

## Silicon photodiode with incorporated V<sub>λ</sub> filter

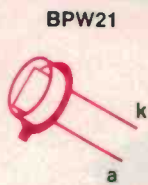

### Special features:

- High reliability
- No testable degradation
- Low noise
- High open-circuit voltage as photovoltaic cells
- Detector for low illuminance
- Short switching time
- High photosensitivity
- Strong logarithmic relation between  $V_0$  or  $I_s$  and illuminance of  $10^{-2}$  to  $10^5$  lx
- Wide temperature range
- Suitable in the range of visible light

Characteristics ( $T_{amb} = 25^\circ\text{C}$ )

Photosensitivity ( $V_R = 5$ V, standard light A, $T = 2856$ K)	$S$	9 ( $\geq 5,5$ )	nA/lx
Wavelength of max. photosensitivity	$\lambda_{S_{max}}$	550	nm
Spectral range of photosensitivity ( $S = 10\%$ of $S_{max}$ )	$\lambda$	350...775	nm
Radiant sensitive area	$A$	7.34	mm <sup>2</sup>
Dimension of radiant sensitive area	$L \times B$	2.71 x 2.71	mm
Distance chip surface to case top edge	$H$	1.9...2.3	mm
Half angle	$\varphi$	60	degrees
Dark current ( $V_R = 5$ V)	$I_R$	2 ( $\leq 30$ )	nA
( $V_R = 10$ mV)	$I_R$	8	pA
Spectral photosensitivity ( $\lambda = 550$ nm)	$S_\lambda$	0.21	A/W
Quantum yield ( $\lambda = 550$ nm)	$\eta$	0.47	Electrons Photon
Open-circuit voltage ( $E_v = 1000$ lx, standard light A, $T = 2856$ K)	$V_0$	390 ( $\geq 320$ )	mV
Short-circuit current ( $E_v = 1000$ lx, standard light A, $T = 2856$ K) (Deviation of $I_s$ linearity in the range of $3 \cdot 10^{-2}$ to $10^4$ lx: max. 12%)	$I_s$	9 ( $\geq 5,5$ )	$\mu\text{A}$
Rise and fall time of photocurrent from 10% to 90% and from 90% to 10% of final value ( $R_L = 1$ k $\Omega$ , $V_R = 10$ V, $\lambda = 550$ nm, $I_p = 9$ $\mu\text{A}$ )	$t_r, t_f$	1	$\mu\text{s}$
Forward voltage ( $I_f = 100$ mA, $E_o = 0$ , $T_{amb} = 25^\circ\text{C}$ )	$V_f$	1.2	V
Capacitance ( $V_R = 0$ V, $f = 1$ MHz, $E_v = 0$ lx)	$C_0$	750	pF
( $V_R = 10$ V, $f = 1$ MHz, $E_v = 0$ lx)	$C_{10}$	220	pF
Temperature coefficient of $V_0$	$TC$	-2.6	mV/K
Temperature coefficient of $I_s$	$TC$	0.12	%/K

Relative spectral photosensitivity versus wavelength

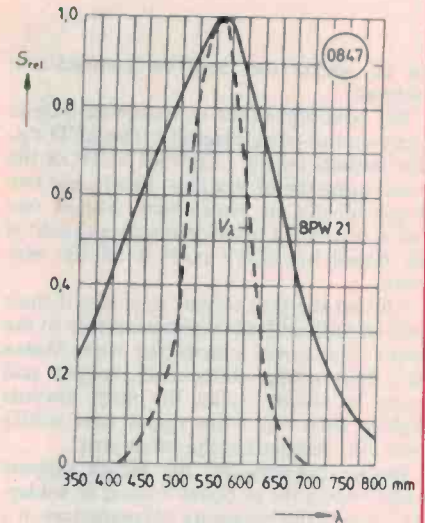

Short-circuit current versus illuminance

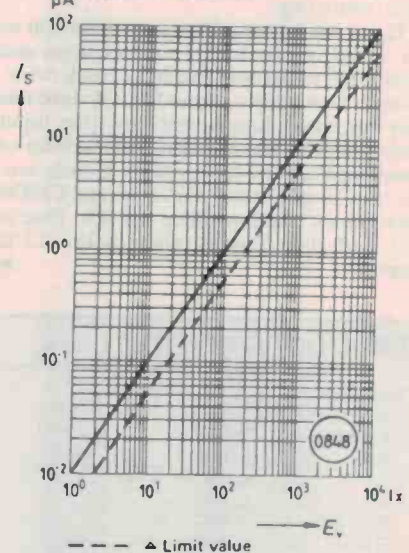

Directional characteristic  
Short-circuit current versus half angle

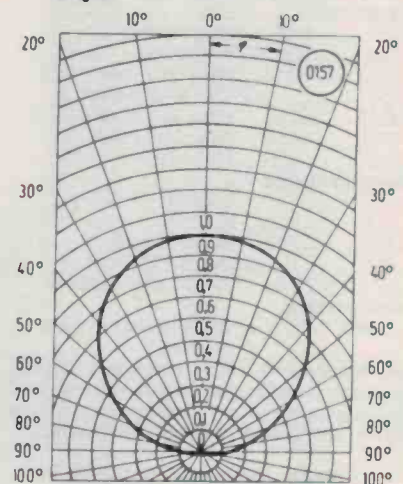

Figure 1. Silicon photodiode characteristics.

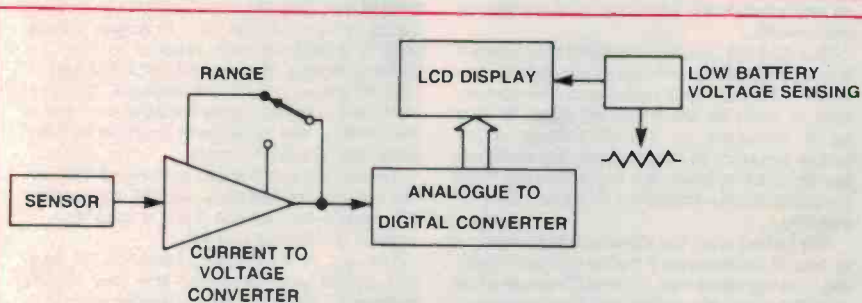

Figure 2. Block diagram.

# Project 182

pin IC socket can now be inserted and soldered.

The next part of the construction is quite tricky and so work carefully. The LCD display mounts on the **COPPER SIDE** of the board using the Molex pins. Firstly, cut two 20-pin lengths of Molex pins. Mount one row in its correct place on the copper side of the board but don't push it all the way down.

I found the pins easiest to solder if their ends sit flush with the component side of the board. This leaves a small part of the Molex pin's legs sitting above each copper pad ready to solder. Lean the strip inwards slightly, then with a fine tipped iron, solder each pin. Repeat for the other strip.

Before breaking off the Molex support strips inspect the pc board around all soldering. Due to the proximity of conductors, it's fairly likely that a solder bridge may have been formed. These must be removed before continuing.

If you are happy with the construction so far, break off the Molex support strips and mount the transistors and IC1 (check orientation). Don't use a socket for IC1 since this may introduce future problems (the input from the photodiode will be in the order of nanoamps so a direct connection from sensor to IC is preferred). Take normal CMOS precautions when handling the ICs. Plug in IC2 and then finally, plug in the LCD display. ▶

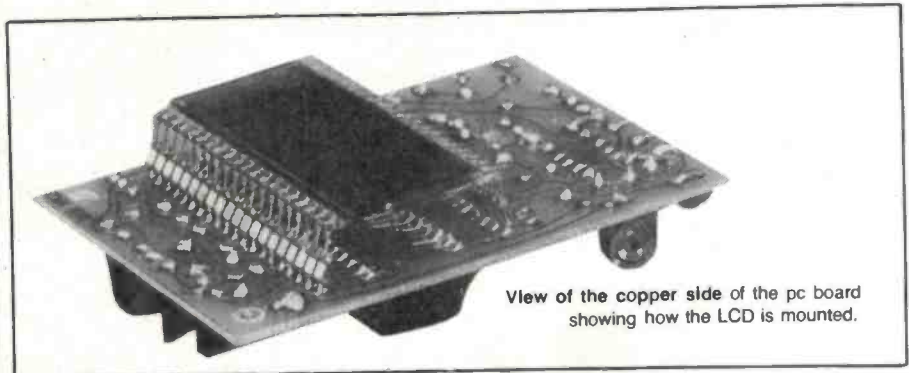

View of the copper side of the pc board showing how the LCD is mounted.

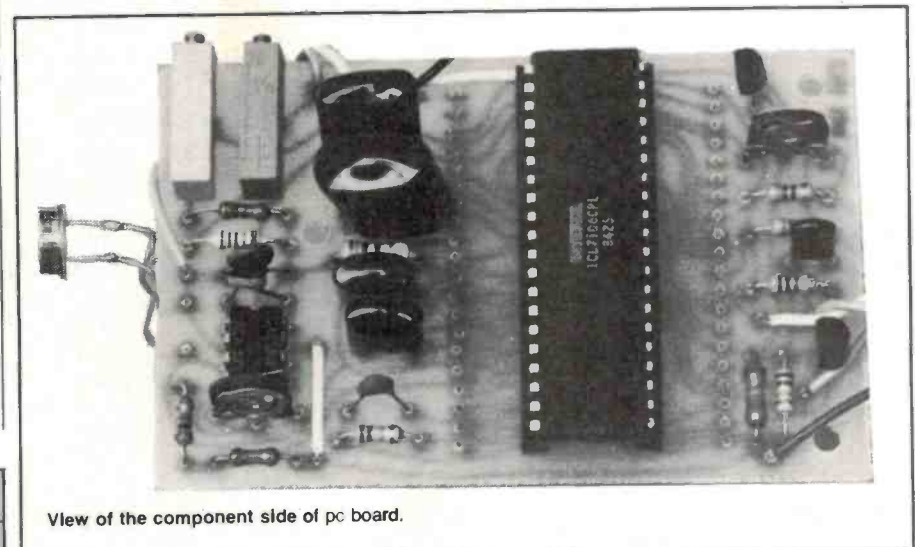

View of the component side of pc board.

## PARTS LIST — ETI-182

<b>Resistors</b> .....	all 1/4W, 5%
R1, R6, R8.....	100k
R2, R4.....	1k
R3.....	27k
R5, R9.....	1M
R7.....	47k
R10, R11.....	4M7
R12.....	680k
RV1.....	100k ten-turn trimpot
RV2.....	1k ten-turn trimpot
RV3.....	100k trimpot
RV4.....	500k trimpot

<b>Capacitors</b>	
C1.....	180p ceramic
C2.....	56p ceramic
C3, C5.....	100n, 50 V mylar
C4.....	100p NPO ceramic
C6.....	470n, 50 V mylar
C7.....	220n, 50 V mylar
C8.....	10n mylar

<b>Semiconductors</b>	
IC1.....	CA3130
IC2.....	ICL7106
Q1.....	BC547, 8 or 9
Q2.....	2N5458, MPP106
D1.....	BPW21 photodiode.

<b>Miscellaneous</b>	
SW1,2.....	DPDT miniature toggle switches

LAD204(or similar) liquid crystal display; ETI-182 pc board; Scotchcal front panel; 150 x 80 x 50 mm multi-purpose box; 9 volt battery clip; three 20 mm 6BA bolts (countersunk head); 9 nuts.

**Price estimate: \$45-\$50**

## HOW IT WORKS

The block diagram shown in Figure 2 gives the overall operation of the unit. Very basically, illumination is converted into a current, current into voltage and then voltage into digital readout.

Photodiode D1 produces an output current proportional to illumination. If this is fed into a short circuit, the current versus illumination characteristic becomes extremely linear, an important feature for any light measuring instrument.

The CA3130 op-amp converts this current into a proportional voltage dependent on the value of the feedback resistance (the op-amp tries to make its input current equal to zero so it produces an output voltage which forces a current to flow through the feedback resistors to balance the input current from the photodiode). Capacitor C1 is included for stability.

The output from the op-amp will contain an ac and dc component if mains operated lighting is being measured. R3 and C3 act as a low pass filter and reduce the 100 Hz component. The resultant voltage is fed into a ICL7106, a digital voltmeter IC which performs all the hard work of displaying its input voltage. More details of the operation of the ICL7106

can be found in the references given in the main text.

One interesting aspect of circuit operation is the method used to provide split rail voltages for the op-amp. The ICL7106 has a built in voltage reference of approximately 2.8 volts between pin 1 (Vcc) and pin 32 (common).

By connecting common, REF LO (pin 36) and IN LO (pin 30) together, this produces voltages of +2.8 and -6.2 to power the op-amp if measured with respect to the fake earth (junction of common, REF LO and IN LO). In actual fact, if the voltages are measured with respect to the negative terminal of the battery, the fake earth point is at +6.2 volts and Vcc is at 9 volts.

To provide a full scale reading of 200 mV, the voltage applied between REF HI and REF LO should be 100 mV. This is provided by voltage divider R3 and R4.

The rest of the circuitry switches the decimal points and performs the low battery monitoring function. This operates exactly as for project 161 Digital Panel Meter in ETI August '82 which can be referred to for more details.

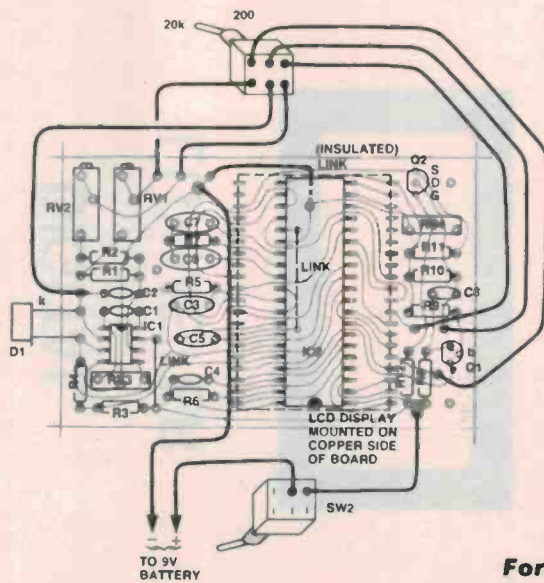
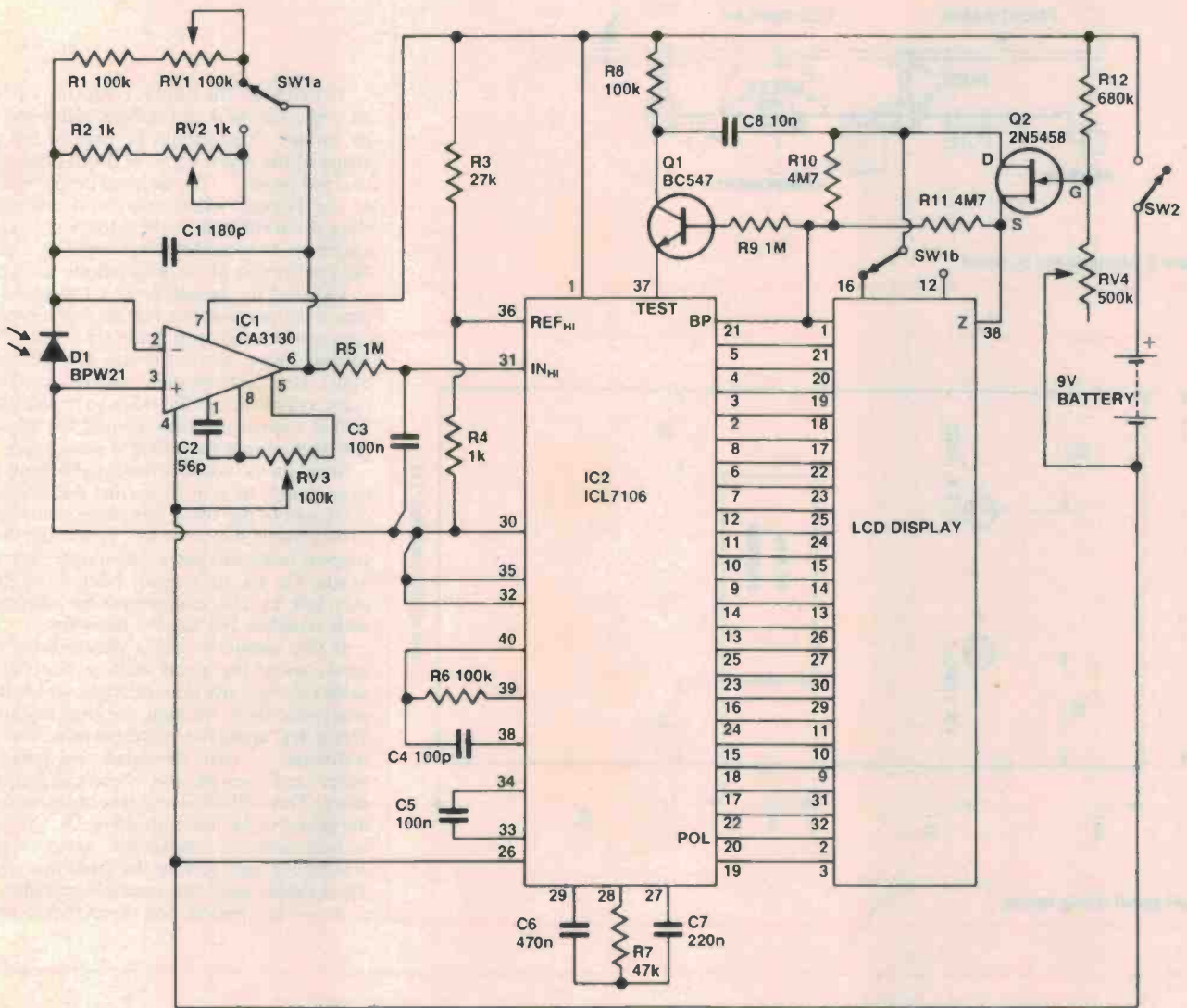

For a guide to components and kits for projects, see **SHOPAROUND** this issue.

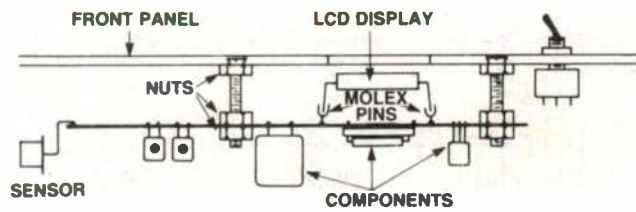

Figure 3. Mounting the pc board.

To orientate the display correctly, tip it at an angle and look at the light reflecting off its surface. You should be able to see the shape of the seven segment displays and the decimal points — the decimal points will sit at the bottom when orientated correctly. Plug it carefully into the Molex pins (you may have to spread the legs slightly). Leave the connection of the photodiode till last.

I housed the prototype in a 150 x 80 x 50 mm multi-purpose box but any other type of case can be used (you could try a 130 x 75 x 40 mm Zippy box but things may get a bit tight). Use the front panel artwork as a template and mark out the holes to be drilled. I drilled numerous holes around the rectangular section and then filed it into shape.

Since the pc board is mounted behind the front panel, sit it in its correct position and mark where the three mounting holes need to be drilled. When drilled, mount the three support bolts into place and countersink the heads. On the prototype, I filled the dimples left by the countersinking operation with Araldite and sanded them flat.

If you intend to use a plastic Scotchcal label, spray the panel with a matt white paint to cover any imperfections which may otherwise show through the thin material. When dry, apply the Scotchcal using the wet technique — soak the label and panel in water and remove the Scotchcal backing sheet. This will allow the label to slide over the panel to be lined up correctly. As long as both surfaces remain wet, you can play around for ages getting the label just right. Then simply wipe the assembly and allow it to dry — hey presto, one perfectly mounted

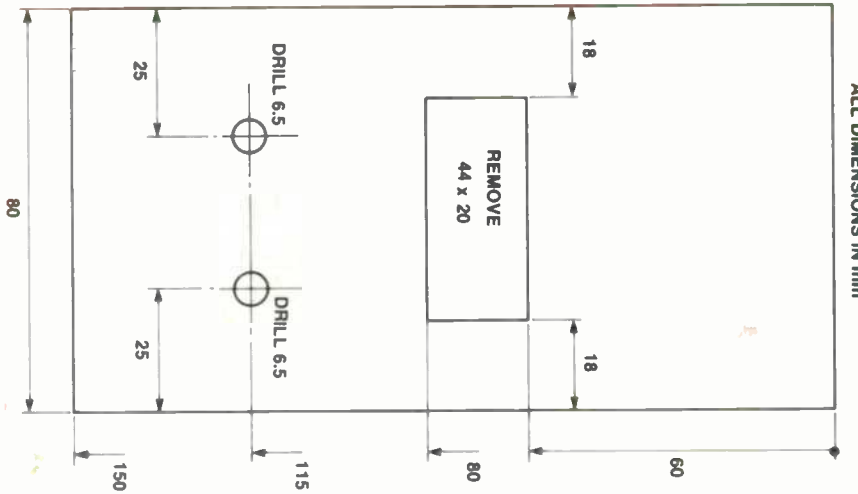

Front panel drilling details

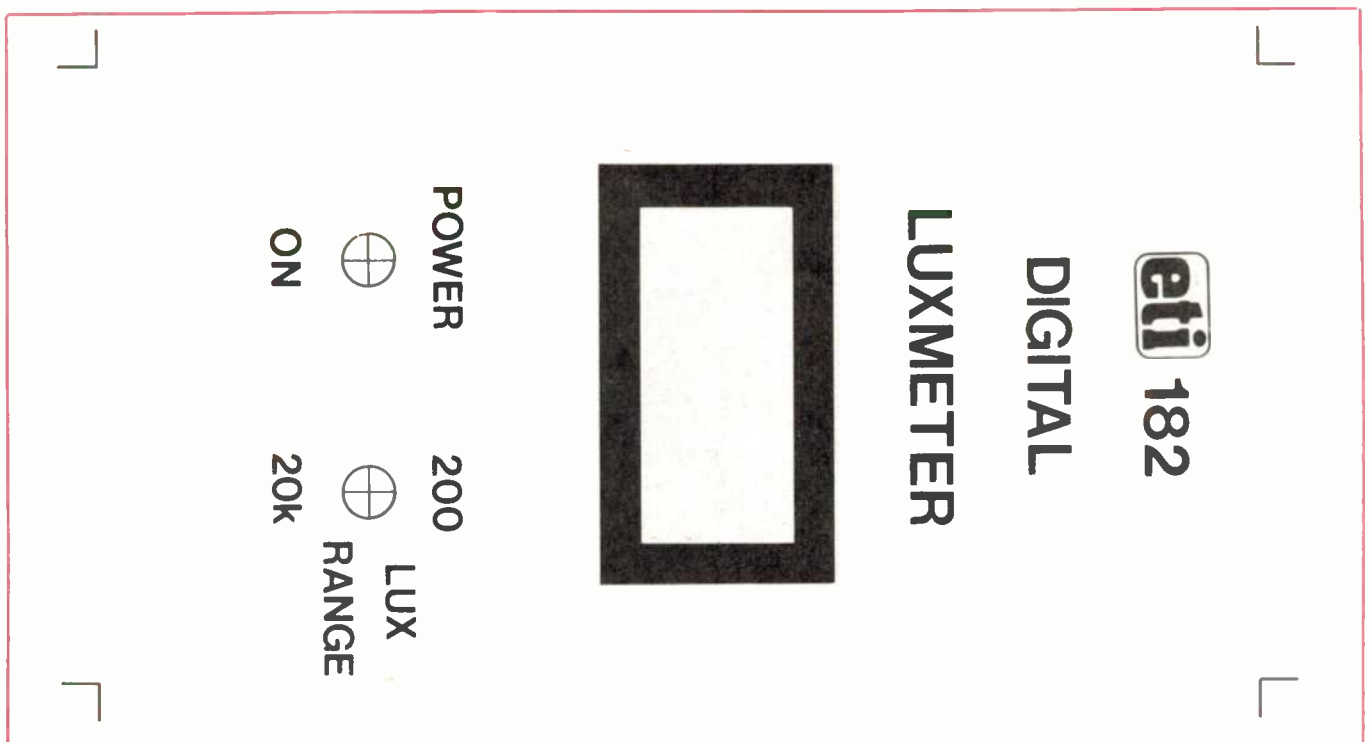

label. Mounting dry Scotchcal onto dry panels only allows you one chance of getting it right — usually you miss.

Next, drill an 8 mm diameter hole in one end of the case to hold the sensor. If your particular case has internal ribs, remove those in the vicinity of the hole to allow the front window of the sensor to sit flush with the end of the case. Mount the two toggle switches and wire the unit as shown in the overlay diagram. Place another nut on each of the support bolts and fit the board into place. A final nut on each bolt will secure the board (refer to Figure 3).

**Setting up**

The first adjustment to be made is the offset trimmer RV3. This should be done BEFORE the photodiode is connected. Simply switch the unit on and adjust RV3 until the display shows 0. If this is not possible with your unit or if the reading on the display wanders randomly, check the orientation of semiconductors and all your soldering. It's no use continuing until this offset adjustment can be made.

If all is well, the photodiode can be attached — check orientation carefully. Use some tinned copper wire to extend the leads by about 15 mm. To set the low battery warning trimpot (RV4), run the unit from

an adjustable power supply set at 9 volts. Watch the reading carefully while decreasing the voltage. When the reading starts to differ drastically from the original, set RV4 so that the LO BAT indicator just comes on. Do not exceed 9 volts on the supply leads when doing this test.

The final adjustment to be performed involves the calibration of the unit. The most accurate way of doing this is to compare the reading with that of a commercial unit. Set up a fixed light source, such as a light globe, and place the commercial light meter at a position which gives a reading of 100 lux. Place the ETI-182 at this same distance, select the 200 lux scale and adjust RV1 until the display shows 100 lux. Next, repeat the exercise with a reading of 1000 lux (by shifting the meters closer to the globe), use the 20k lux range and adjust RV2.

If you don't have access to a commercial light meter, the following not-quite-so-accurate method can be used for calibration. Set up a 100 watt light globe in an area where there are no reflecting surfaces, brightly coloured walls or mirrors. The illumination level at 300 mm from the globe will be 1000 lux and at 750 mm, 160 lux. Simply place the meter at each of these distances and set the appropriate trimpots.

The unit is now ready for use.

eti 182

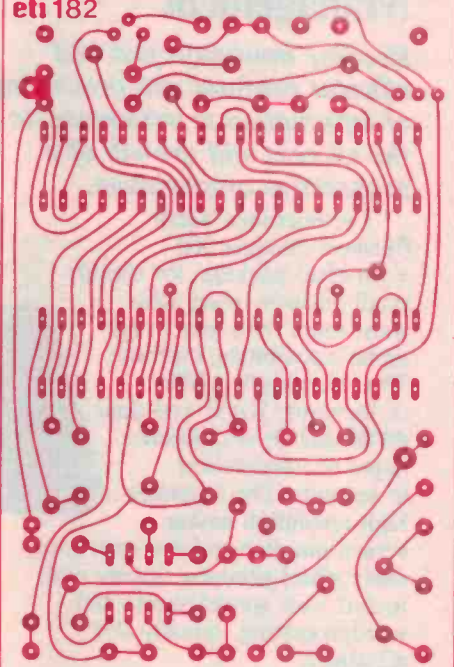

# SALE

HUGE DISCOUNTS

20%-30% OFF

CRAZY LOW PRICE!

HOME Computer System

\$149

PENCIL II COMPUTER WITH 22 SOFTWARE PROGRAMS

Was \$229

A New 780 based home computer with a full set of programs to get you started. Includes 100K RAM (extra 16K or 64K avail), 6 user keys.

NEW PROFESSIONAL ALARM CONTROL UNIT

\$99

SCOOP BUY! HALF PRICE ALARM CONTROL BOX - JUST \$99 Built/tested. Similar alarm boxes sell for upto \$199. Built for Aust. home, office, factory!

- Heavy duty steel cabinet (lockable).
- Sophisticated & versatile circuitry.
- Adj. entry, exit & adj. reset delay
- N.O./N.C. instant, N.C. delay oper.
- Inbuilt siren, add horn speaker(s).
- 6x LED status indicators, all modes
- Inbuilt 24hr panic or fire circuit.

Lots more features, send for brochure

SPEAKER BOX SALE

Walnut/teak finish, ready-built but no front baffle. SHOP SALES ONLY

EACH \$6

620mm X 350mm X 225mm Deep

DISCO STROBE

\$19.50

NEW

FLASH RATE-0-12/Sec  
Mains operated, ideal for parties, discotheques, etc, variable flash rate, teak finish wood cabinet, NEW IMPROVED MODEL!

90 DAY WARRANTY.

MAGNETIC REED SWITCH

\$2 EACH SET

For all doors and windows, NC contacts, normally \$2.50 set.

ULTRASONIC BURGLAR DETECTOR

\$49

FOR HOMES, SHOPS, AND OFFICES. Covers 40 sq. metres, ceiling or wall mounting, sensitivity adjustable, 12V DC operation, suit alarm control unit above.

5" HORN SPEAKER

8 OHMS 8 WATTS

\$8.50

USUALLY \$11.50

LOOK AT THIS...

A REAL SCREAMER!!!

12V PIEZO ALARM SIREN

Covers 40 sq. metres, ceiling or wall mounting, sensitivity adjustable, 12V DC operation, usually \$19.50 each

\$16

DB25 FEMALE SOCKETS

\$1.25 EA.

NEW, MANUFACTURED BY PLESSEY GOLD-PLATED CONTACTS LIMITED QUANTITY

Tape heads

\$10

Stereo Rec/Play or erase \$10 Mono \$3 Rec/Play \$3

SAVE YOUR DOLLARS

IMPROVE YOUR HI-FI SOUND WITH A FANTASTIC ARISTA MOVING COIL CARTRIDGE

MODEL MC100

SAVE OVER 20% \$19.50

- Standard 1" mounting.
- Ceramic Dshalt magnets for high output (transformer not needed).
- Freq. response 100-35KHz.
- High 2.5V output (180W/0.0001)
- Tracking force 2.0 grams.
- 0.5µm Diamond tip.
- Complete mounting kit incl.
- Stylus easily replaced (\$15.00)

PACK/POST: \$2 PLUS 5% ORDER VALUE.

ULTRASONIC CAR BURGLAR DETECTOR

\$44

Protects the interior of your vehicle from illegal entry. NO/NC contacts allows use with most alarm systems. Normally \$59.

LM3900

39¢ EA 1-9 WERE 50¢ EA 10+ 29¢

RCA 3401 EQUIVALENT SUPPLIED!

C106 SCR

32¢ EA 10-99 29¢ EA

50V 4A

PRE-PAK electronics p/l

1a WEST ST, LEWISHAM, NSW

569-9797

24 HR PHONE ORDER SERVICE

Phone or mail order

BANKCARD accepted

## For all small and Personal Business Management

*Because nowadays fast and efficient retrieval and processing of information is paramount to the success and growth of a progressive organisation.*

The microbee Small Business Success Kit is an ideal package for serious small business users who want more than just a 'big name' accounting machine. The microbee's 128K of Dynamic RAM and dual 400K disk drives, process pages of information in seconds. The microbee high resolution amber screen monitor and dot matrix or daisy wheel printers, display and record your spread sheets and wordprocessing quickly and accurately.

The microbee's now famous bundled software provides you with a comprehensive library of programs for all Small Business needs, including Wordstar/Mailmerge 3.3, Microsoft Basic, Telcom Communications Package and a full range of support utilities, training guides and tutorials.

128K microbee, dual 400K slim line floppy disk drives, hi-res green screen monitor, bundled software and manuals . . .

**\$1995** incl. sales tax.

With microbee dot matrix parallel printer and optional hi-res amber monitor . . .

**\$2395** incl. sales tax.

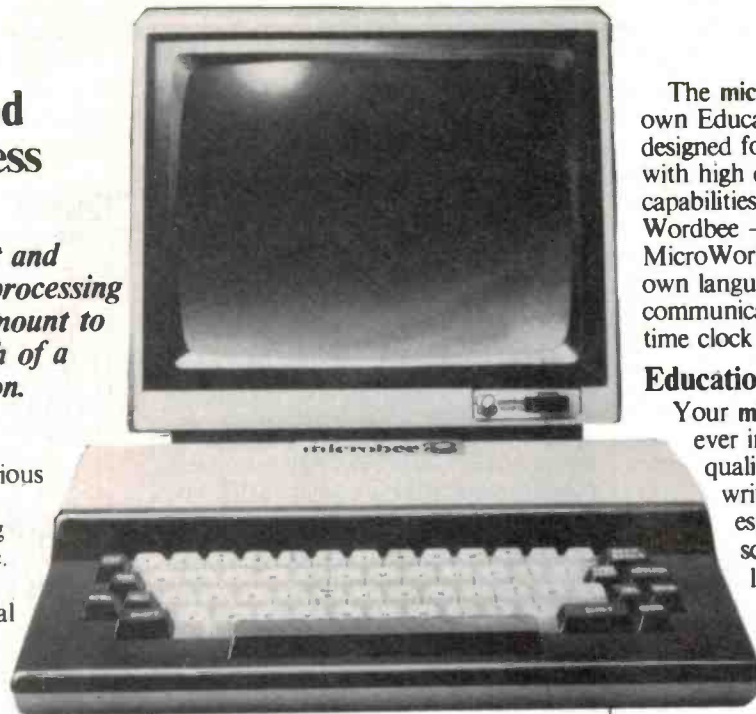

# A BEE FOR ALL REASONS

## For Education

*Because Education is a Priority and your children deserve the best.*

It is no coincidence that microbee's educational software is entitled "Learning Can Bee Fun". The microbee has proved that learning can be fun, and by doing so, has gained the endorsement of the Australian Schools Commission, the majority of Depts. of Education throughout Australia and the Education Department in Israel. More recently the Swedish Schools Dept. have chosen microbee after months of stringent tests and stiff opposition from the big American, British and Swedish manufacturers.

The microbee is indeed Australia's own Educational Personal Computer, designed for the classroom and home, with high quality graphics, sound effect capabilities, built-in software including Wordbee — the wordprocessor, MicroWorld BASIC — the microbee's own language, and Telcom — the communications package, with a real time clock and alarm features.

## Educational Software Support

Your microbee is supported by an ever increasing range of high quality software, developed and written by Australians, especially for Australian schools and students. A full list of available teacher support resources for the microbee is available from your nearest microbee Technology Centre.

microbee 16K Educator . . . **\$449**

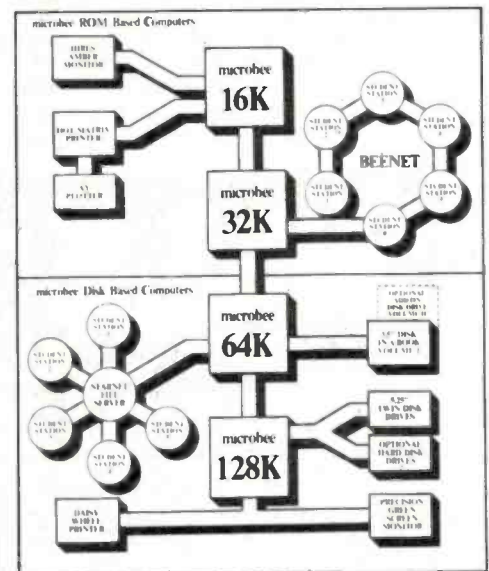

## For Communication

*Because we need to communicate our ideas and data.*

From home to office, around your network or around the world, with microbee you can tap into Bulletin

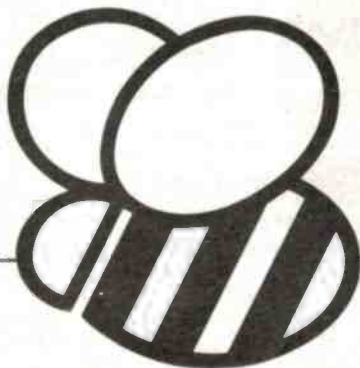

# microbee



**DIRECT ORDERS**  
**PHONE (02) 487 2711**  
**TELEX AA72767**  
**APPLIED TECHNOLOGY**  
**RETAIL PTY LTD**



boards and benefit from Public Domain software.

Share your experiences and learn from others treading the same path that you choose.

microbee 32K Communicator Workstation . . . . **\$599.00**

incl. sales tax.

includes 32K microbee Series 111 and hi-res green screen monitor.

Available separately:

microbee 32K Series 111 . . . . \$499.00

Hi-res green monitor . . . . . \$149.50

Hi-res amber monitor . . . . . \$169.50

Swivel base . . . . . \$24.50



## NEW 3.5" Disk Computer- In-A-Book

The smartest new development in the Microcomputer World is the new high density, low cost 3.5" disk drive. Already standard on many 'big name' systems, the 3.5" disk has the same, or more storage capacity than the standard 5.25" disk, and is far more compact.

The microbee Computer-In-A-Book available in matching volumes is expandable to meet your growing needs.

The microbee Computer-In-A-Book VOLUME 1 includes microbee 64K, single 3.5" disk drive and software on diskette, including Demonstration Programs, MicroWorld BASIC, Wordbee, Telcom and CP/M with Utilities — a matching manual is available.

**VOLUME 1 \$995** incl. sales tax.

VOLUME 2 is an add-on disk drive in a matching volume

**VOLUME 2 \$345** incl. sales tax.

## For experiments and personal development

*Because microbee is the ideal Hackers micro*

There is a wealth of experiments and Hacker's hints being published regularly in several enthusiasts' magazines and computer publications. See the microbee Hackers Handbook. Explore robotics, music and speech synthesis, tune into weather map facsimiles and decode radio teletype information. The scope is limited only by your imagination.

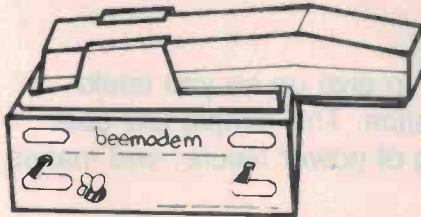

## For games and entertainment

*Because playing is the root of all learning.*

Fight in space, land a helicopter, explore the Dungeons of Khan — or is a challenging game of Chess more your speed? Whatever turns you on, microbee's high resolution picture



128K Small Business Computer

and built-in sound effects will keep your microbee turned on for hours and hours every day.

## Upgradeability

When you buy a microbee personal computer, rest assured, you have made the right decision. Your microbee will never become obsolete — on the contrary, your microbee is fully upgradeable and can grow from 16K to 32K to 64K and even to 128K. Disk drives can be added, as can a whole host of useful and interesting peripherals, such as printers, plotters and modems. Whatever level at which you choose to start, your microbee will grow with you, providing challenges and encouragement along the way.

## Quality Control and Service

The microbee is designed and manufactured in Australia under strict computer controlled standards, and is backed by a strong national service team, operating from West Gosford and through microbee Technology Centres Australia wide.

### microbee technology centres

N.S.W.  
1 Patterson Ave, Waitara 2077  
Phone (02) 487 2711

VIC.  
729 Glenferrie Rd, Hawthorn 3122  
Phone (03) 819 5288

W.A.  
141 Stirling Highway, Nedlands  
Phone (09) 386 8289

S.A.  
151 Unley Road, Unley 5061  
Phone (08) 272 1384

QLD  
455 Logan Road, Stones Corner, 4120  
Phone (07) 394 3688

FACTORY  
Koala Crescent, West Gosford 2250  
Phone (043) 24 2711

### Authorised Dealers in:

- Coffs Harbour (066) 52 7530
- Lismore (066) 21 8180
- Glen Waverley (03) 233 9665
- Townsville (077) 75 4000
- Port Lincoln (086) 82 1666
- Mount Tom Price (091) 89 1383
- Launceston (003) 31 7890
- Wauchope (065) 85 3311
- Milton (07) 371 6888
- Cairns (070) 51 4341

See exciting new  
microbee releases  
at PC'85  
(Centrepoint, Sydney,  
March 13-16th)

# LOW BATTERY VOLTAGE INDICATOR

Knowing your batteries are about to give up on you could save many an embarrassing situation. This simple low cost project will give you early warning of power failure, and makes a handy beginner's project.

Robert Irwin

**THE PERENNIAL PROBLEM** with any piece of equipment run from some form of battery is to know that you're running out of battery power before the equipment actually stops working. Some battery powered equipment has built in warning of the impending demise of the power supply but a lot just keep you in the dark until your battery-powered super egg timer suddenly doesn't send the required strobe pulse to your computer which, in turn, fails to turn off the microwave and you end up with egg on your face and a divorce suit because the breakfast in bed that you meant to give your wife for the 25th wedding anniversary never arrived.

The ETI-280 can solve all these problems by giving a visual indication (by way of a flashing LED) that your battery is on the decline. The circuit is simple and small enough to be installed inside most equipment and requires no modification to existing circuitry. Although the prototype was designed to work from units working off a 9 V battery, any battery voltage from 6 V to 18 V can be accommodated simply by changing certain resistor values.

## Design

The circuit uses a programmable unijunction transistor to sense the difference between a reference voltage and a monitor voltage (derived as a proportion of the battery voltage). To achieve a stable reference an LM336-5 V precision reference was used in preference to a zener because of its lower current drain. The circuit will draw 1 mA or less from the battery when in use. A relaxation oscillator circuit is used to flash an LED as a visual indication that the battery is failing. When the battery is in its 'operating' range (usually down to about 75 per cent of its rated voltage) the LED will re-

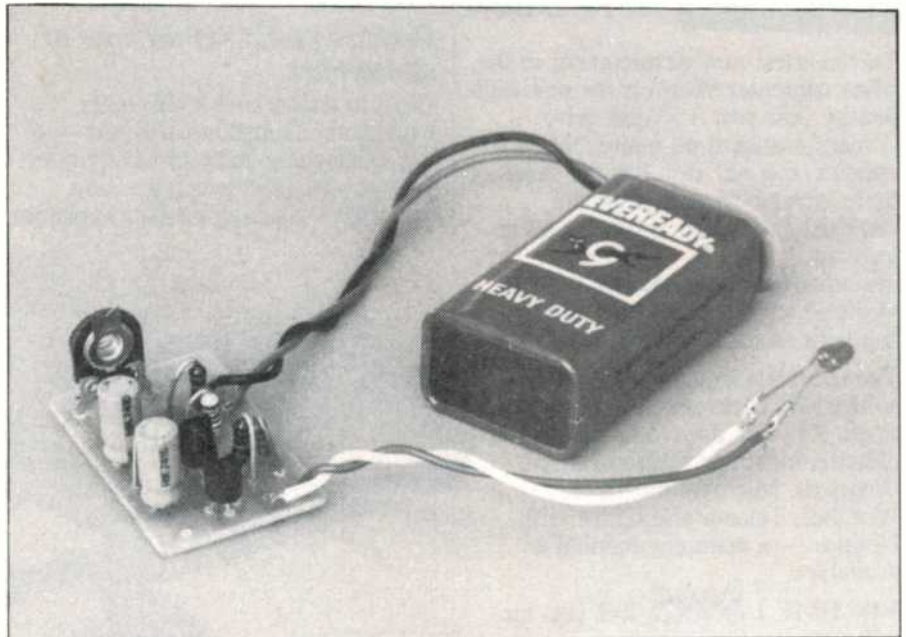

main off but when the voltage gets below the allowable minimum the circuit will activate and cause the LED to flash. As the battery voltage gets worse the LED will flash at a faster rate indicating that the battery is approaching exhaustion. The voltage at which the LED begins to flash can be adjusted over a limited range by adjustment of the control voltage of the LM336.

You will generally have about an hour or two of running time left after the LED has started to flash.

## Different battery voltages

As mentioned earlier, the prototype was designed for use with 9 V battery equipment but, by suitable substitution of resistors, a variety of voltages can be accommodated. A Table is given for suitable component values for 6, 9, 12 and 18 volt operation. The method of selecting these values is given in the "How it works" section and this will allow you to work out your own values for any voltages not given in the Table.

# low battery voltage indicator

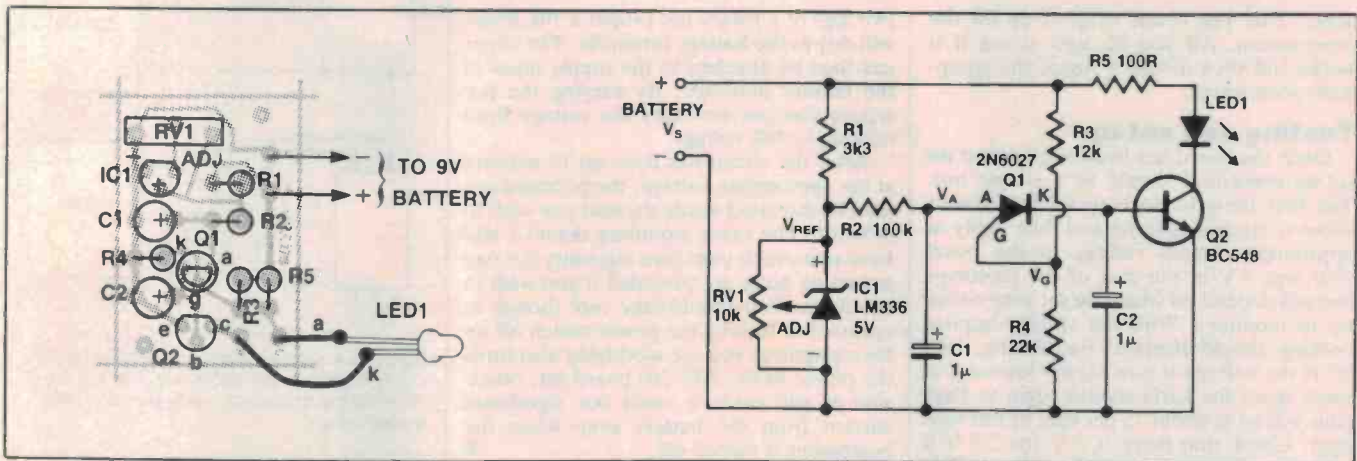

## PARTS LIST — ETI-280

### Resistors

R1.....	3k3
R2.....	100k
R3.....	12k
R4.....	22k
R5.....	100R
RV1.....	10k trimpot

### Capacitors

C1, C2.....	1 µF, 25 V electro.
-------------	---------------------

### Semiconductors

Q1.....	2N6027 programmable unijunction
Q2.....	BC548 or similar
IC1.....	LM336-5 V
LED1.....	3.5 mm red LED

### Miscellaneous

ETI-280 pc board; hookup wire.

**Price Estimate: \$5-\$8**

## Construction

The construction of the circuit is not critical. If you are adventurous enough you can use the pc board of the equipment you're adding the battery indicator to; drill a few holes in a spare space, then wire up the circuit on it. If you would rather not go playing round with the existing pc board then you can use the ETI-280 pc board. Give the board a good visual inspection and make sure there are no broken or shorted tracks. All components with the exception of the LED mount directly on the pc board. Begin with the resistors and capacitors. Note that the resistors are all mounted vertically to save space so you will have to bend one leg over to mount them. If the board is going to be mounted in a tight space near other components it may be wise to put an insulation sleeve over the long leg of the resistor so that it won't short out on anything. Make sure that you take note of the polarity of the capacitors. The two transistors and the IC can be mounted next. Once again take careful note of the polarity of these compo-

## HOW IT WORKS — ETI-280

The heart of the circuit is a 2N6027 programmable unijunction transistor (PUT). A PUT acts a little like a SCR but can be turned off as well as on by the gate. Essentially, if the voltage on the gate drops to 0.6 V below the voltage on the anode, the PUT will start to conduct from anode to cathode. If the gate voltage is not lower than anode by more than 0.6 V then the PUT will be in nonconduction mode. In this circuit the PUT is used as a comparator. The anode voltage ( $V_a$ ) is held at a constant 5 V by the LM336-5 V precision reference. The gate voltage ( $V_g$ ) is derived as a proportion of the supply voltage determined by the resistive divider network of R3 and R4. As the supply voltage falls (as happens when the battery begins to fail or is heavily loaded) the voltage,  $V_g$ , falls. When  $V_g$  falls to  $V_a - 0.6$  V (4.4 V) the PUT begins to conduct and turns on the transistor, Q2, which turns on the LED. To cause the LED to flash, C1 is configured as a relaxation oscillator. When Q1 conducts C1 is discharged quickly through the transistor and the anode voltage on Q1 drops. When it drops to a sufficient level the PUT will be turned off (thus turning off the LED and Q2). The capacitor, C1, will then charge up through R2 until the anode of Q1 is once again 0.6 V higher than  $V_g$  and the PUT turns on again. The cycle is then repeated.

Capacitor C2 acts to stretch the on time of the transistor so that the LED flash is not too

short to be seen. R1 sets the bias current for the LM336 and R2 limits the current through the LED. RV1 allows a limited adjustment to the LM336 reference voltage over a range of about  $\pm 1$  V.

The current drain of the circuit is around 1 mA or less. This is primarily determined by R1.

### SELECTING COMPONENT VALUES

The Table given shows values for components for some of the more popular battery voltages. If you wish to use voltages other than those shown use the following criteria:

- R1 should be chosen to limit the current to 1 mA at full battery voltage, for example for 9 V  $R1 = (V_s - V_{ref})/1 \text{ mA} (= 3.3 \text{ k}$  to the nearest standard value).

- R3 and R4 should be chosen so that, at 75 per cent of full voltage, the voltage on the gate of the PUT is  $V_{ref} - 0.6$  V. Also, the total of R3 + R4 should be between 20k and 50k. For example for 9 V supply we want  $V_g = V_{ref} - 0.6$  V when the battery has dropped to 75 per cent of its full voltage, that is so  $R4/(R4 + R3) = (V_{ref} - 0.6)/6.75$ . Choose R3 = 12k and R4 = 22k.

- R5 is not critical but should be chosen to limit the maximum current through the LED to about 80 or 90 mA.

It should be noted that for voltages less than 9 V, the reference should be changed to 2.5 V instead of 5 V.

Voltage (V)	R1	R3	R4	R5	IC1
6	3k3	22k	15k	100R	LM336 2.5 V
9	3k3	12k	22k	100R	LM336 5.0 V
12	6k8	22k	22k	220R	LM336 5.0 V
18	15k	22k	10k	220R	LM336 5.0 V

Table for determining component values for various supply voltages. Note that for 6 V operation an LM336-2.5 V reference is used instead of a 5 V reference.

# Project 280

nents. That just about wraps it up for the construction. All you do now is see if it works and then mount it inside the equipment somewhere.

## Testing and set-up

Once the board has been constructed the set-up procedure should be a simple one. The first thing to do is to set the trimpot wiper to its mid position and then apply an appropriate supply voltage to the board (this was 9 V in the case of the prototype but will depend on what you set your circuit up to monitor). With the voltage applied nothing should happen! Fascinating, isn't it? If the voltage is now slowly lowered, at some point the LED should begin to flash (this will be at about 75 per cent of full voltage). Check that there is 5 V (or 2.5 V if you are using a 6 V supply) at the positive pin of the LM336. If the supply voltage is lowered still further, the LED will flash faster. The point at which the LED begins to flash can be adjusted by the setting of the trimpot.

The above set-up can easily be done if you have a variable power supply. If not, then you can make a simple variable supply with a battery and a pot. Just get a battery of the same voltage as that which you have set your circuit up to monitor and solder the

two legs of a rotary pot (about a 10k linear will do) to the battery terminals. The wiper can then be attached to the supply input of the battery indicator. By varying the pot setting you can now vary the voltage from nothing to full voltage.

After the circuit has been set to indicate at the appropriate voltage, the pc board can then be mounted inside the unit you wish to monitor. The exact mounting details I will have to leave to your own ingenuity but two mounting holes are provided if you wish to use them. You should take care though to ensure that turning the power switch off on the equipment you are modifying also turns the power to the ETI-280 board off, otherwise it will drain a small but significant current from the battery even when the equipment is turned off.

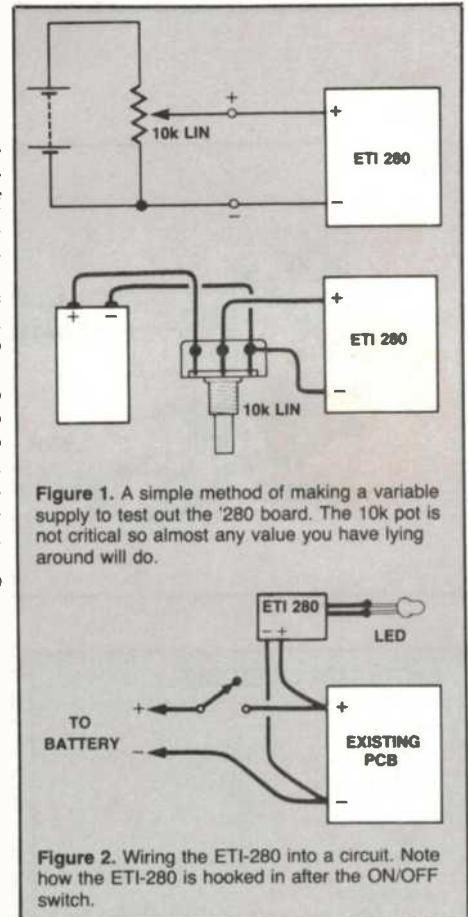
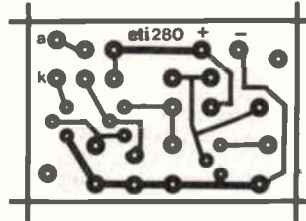

Figure 1. A simple method of making a variable supply to test out the '280 board. The 10k pot is not critical so almost any value you have lying around will do.

Figure 2. Wiring the ETI-280 into a circuit. Note how the ETI-280 is hooked in after the ON/OFF switch.

## SWITCHING POWER SUPPLIES

AVAILABLE FROM

# TDK

To meet variety of needs, TDK switching power supply is available in 14 series, composed of some 250 types of standard models, covering a power range of 10W to 300W and a choice of DC or AC input. All models feature a unique transformer design using TDK ferrite and carefully selected component parts, and also feature simple circuitry for high efficiency, high performance, and high reliability.

- A unique transformer design based on TDK high performance ferrite.
- Simple circuitry • Strict control of heat.
- Only carefully selected parts are used.
- Noise prevention is considered totally.
- Standardization is promoted by providing optimum number of series.

### S&C

## AUTOMATION & CONTROL

Components Division

2 GIFFNOCK AVENUE, NORTH RYDE 2113

PHONE: (02) 887-6222

## WOW! IT'S HERE Get Your Copy !!!

# \$3.95

200 CIRCUITS  
AND IDEAS  
FOR THE  
ENGINEER  
TECHNICIAN  
& HOBBY  
ENTHUSIAST

# Circuits

## COOKBOOK #5

AN ELECTRONICS TODAY PUBLICATION  
THE FEDERAL PUBLISHING CO. PTY. LTD.  
Telephone (02) 663-9999

**SPECIAL SAVINGS FOR OUR READERS**

**FANTASTIC SOLAR POWER**

CASIO FX-450

**CASIO SCIENTIFIC POCKET-FOLD CALCULATOR**

- Works without batteries • Magic Touch Leaf Keys
- Works by Solar Power, daylight & any lamplight
- Liquid Crystal Display
- 68 Scientific functions • Folds to pocket-size
- Binary, octal, and hexadecimal calculations/conversions, logical operations and 9 physical constants.

**SAVE \$30**

**\$39**

*DIMENSIONS 11mm x 78mm x 125mm (1/2" x 3" x 5") closed  
WEIGHT 97g (3.4 oz.)*

**NO BATTERIES**

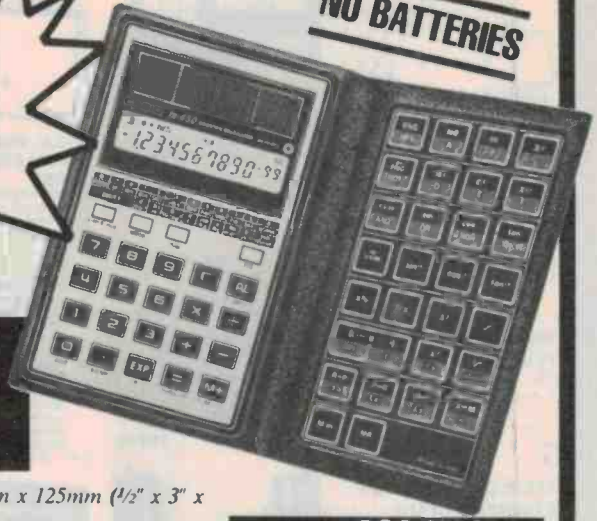

**R.R.P. \$69.95**

**BIG SAVINGS FOR ALL OUR READERS! . . .**

**SAVE \$20**

R.R.P. \$159



OUR PRICE

**\$139**

**MUSIC, MUSIC, MUSIC !!!**

**with Casiotone MT-35 ELECTRONIC KEYBOARD**

- Slim, light and easy to play
- 4 Built-in Rhythms, Rock, Swing, Bossa nova, Waltz
- 6 Preset sounds, Piano, Ele. Piano, Organ, Oboe, Clarinet, Vibraphone.
- Has own speaker or plugs into your stereo system
- Auto-accompaniment with just one finger
- Output jack for headphones (not included)
- Includes shoulder strap and carry-case

*DIMENSIONS 49 x 645 x 138mm Weight 1.6kg*

**MAIL YOUR ORDER NOW!**



**SAVE \$39**

**\$79.95**

R.R.P. \$119

**CASIO PB-110 POCKET COMPUTER**

- Employs standard BASIC. • 5 x 7 dot matrix, liquid crystal, 12 digit display. • Has DATA BANK to store phone numbers, addresses and other information. • Keyboard uses ASCII format. • Plays computer games with real sound signals using BEEP command. • Up to 10 program areas usable simultaneously. • Most frequent commands can be input directly for quick programming. • Good for computer students and people on the move. • Optional character printer available. • Powered by 2 lithium batteries — up to 140 hours of cont. use. • Includes Easy Guide to Programming and Data Bank Ref Manual.

*DIMENSIONS 9.8 x 165 x 71mm (1/2" x 6 1/2" x 2 3/4") WEIGHT 119g*

**TO FEDERAL MARKETING MAIL ORDERS**

PO BOX 227 WATERLOO 2017  
PLEASE RUSH ME (Postage & Handling Included)

- Indicate Choice/Quantity
- ..... fx-450 Calculator, complete as advertised here for \$39
  - ..... MT-35 Casiotone Keyboard complete as advertised for \$139
  - ..... PB110 Pocket Computer complete as advertised for \$79.95

NAME ..... (PLEASE PRINT)

ADDRESS .....

POSTCODE .....

SIGNATURE .....

American Express  Bankcard  Cheque\*

\*Please make cheques payable to the Federal Publishing Company Pty. Ltd.

Credit Card No: \_\_\_\_\_

Card Expiry Date: ..... Allow four weeks for delivery.

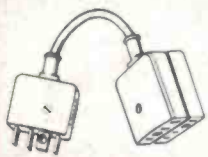

### TELECOMMUNICATION PLUG TO 2 SOCKETS.

Ideal for modem connections  
Cat. Y16014 \$12.95

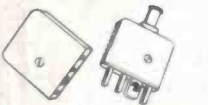

### TELECOMMUNICATION PLUG/SOCKET

Plug Cat. Y1601 \$3.95  
Socket Cat. Y1601B \$4.95



### TELECOMMUNICATION EXTENSION LEADS

Cat. Y16010 5m \$12.50  
Cat. Y16012 10m \$14.95



### NATIONAL RECHARGEABLE DRILL/SCREW DRIVER EZ505

- ★ Quick 1 Hr. Charging
  - ★ 4 Stage Torque Control
  - ★ 2 Speed Switch
  - ★ Handle Storage Compartment
  - ★ Forward/Reverse Operation
  - ★ National Quality
  - ★ Spare Battery Pack Available
- Cat. T12320 \$149.00



### DIGITAL MULTIMETER YFE YF1100 FEATURES

- Large easy to read 3 1/2 digit display
  - Facilities for transistor and diode testing
  - Clearly laid out front panel
  - 10A DC AC range
  - Priced to undersell the others
- Cat. A16025 \$59.50



### WE HAVE DONE IT AGAIN!!

- New multimeter at unbeatable value for under \$45! The new YU-FONG YFE-1030C features:
- Large 3 1/2 digit display (1 1/2 inch high)
  - Autopolarity, "-" display for Negative input.
  - High over-load protection for all ranges.
  - Over-load display highest figure "1" or "-1" alone glows.
  - Power consumption 20mW approx.
- Cat. \$44.95



### RELAY AND BASE

Can carry 10A at 28V DC or 5A at 240V AC. Supplied with Chassis Mounting Socket with screw terminals. Great for school projects and demonstrations. Switching DC power supplies, central circuits and with contacts installed up to 20A can be switched. Normally \$8.95  
Cat. S14014 This month \$6.95

### MAGNETIC REED SWITCHES

N.C. Cat. S15057 \$1.95 \$1.85  
N.O. Cat. S15058 \$1.95 \$1.85



### BICYCLE COMPUTER

Fantastic 12 function, dual L.E.D. Display, very popular in the USA and now available at Rod Irving Electronics  
**FEATURES:**

- 3 Speed functions: Instantaneous Average speed and Maximum speed reached.
- Distance travelled.
- Target Distance (Perfect for training) with 1/4, 1/2, 3/4 bar graph display.
- Pacer: Audio, 2 Speeds
- Clock/Stopwatch/Journey time
- Calories used
- Miles or Kilometres.
- Memory: Time, bodyweight, type, size, target size, target distance.
- Friction free magnetic sensor.
- Easily fitted, easy to detach for security.
- 90 Day Warranty.

Cat. \$59.95

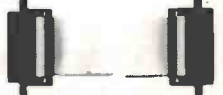

### READY MADE CABLES

Serial to Serial Cat. P19011 \$23.50  
Parallel centronics to centronics. Cat. P19013 \$34.50

### TELECOMMUNICATIONS CABLE

2pr. Cat. W11302 \$0.75m  
3pr. Cat. W11303 \$0.90m  
10pr. Cat. W11310 \$1.95m

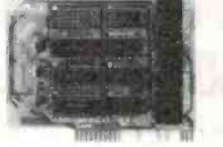

### APPLE COMPATIBLE CARDS

Printer Card Cat. X17029 \$65.00  
Drive Card Cat. X17019 \$80.00



**NEW IC'S**

1-9	10+
41256	\$24.95 \$23.95
27128	\$19.50 \$18.75
74HC02	\$ 0.50 \$ 0.40
57716 R.F. Mod	\$64.95 \$59.95



### P.A. SPEAKERS

Low dual cone, wide range, 200mm (8in.). Ideal for public address, background music, etc. Tremendous Value at these prices!  
Cat. C12000 1-9 10+  
\$5.95 \$4.95

### ECONOMY 19" RACK CASE

Cat. H10400 1-9 10+  
\$34.95 \$29.50

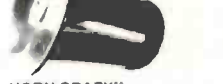

### HORN CRAZY!!

8W, aluminium or plastic. Normally \$9.50  
Aluminium Cat. C12015  
Plastic Cat. C12010 1-9 10+  
\$6.50 \$5.95



### PLASTIC COMPUTER CASING

A stylish low profile case to give your system the professional look it deserves. Provision for two 5 1/4" slimline drives.  
Cat. X11080 \$75.00

## ALARM PRODUCTS!



### LOCAL BURGLAR ALARM CONTROL PANEL

The odds against you are climbing and prevention is better than cure!

- Adjustable exit/entry time delay and alarm time (avoids unnecessary noise pollution)
- 12V D.C. 1.5Amp
- Provision for battery back-up.
- Tamper switch
- Optional outputs: Sirens, bells, floodlights, automatic diallers, tape recordings, closed circuit TV, etc.
- Accepts N.C. and N.O. detectors such as Infrared, microwave, ultrasonic, wireless, vibration sensor, magnetic switch, door mat, smoke detector, glass breakage sensor panic button etc.

Cat. S15051 \$79.95



### ULTRASONIC BURGLAR ALARM

- Easy to install
  - Connect with magnetic switch, infrared detector, etc.
  - Equip with home speaker, lockswitch, flashlight, closed circuit TV, etc.
  - Rechargeable battery circuit with recharge indicator L.E.D.
  - N.O. and N.C. circuit breakdown indicator
  - Low dry battery indicator
- Cat. S15052 \$89.95



### GLASS BREAKAGE DETECTOR

Adjustable for closed circuit or open circuit type glass. Instructions supplied.  
Cat. S15060 \$3.95



### 4" BELL

12V D.C. 250mA  
Cat. S51072 \$9.95

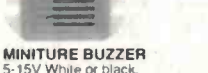

### MINITURE BUZZER

5-15V White or black  
Cat. A15062 1-9 10+  
\$1.95 \$1.75



### HORN SIREN

12V DC, 8W  
Cat. C12012 1-9 10+  
\$14.95 \$13.95



### ULTRASONIC MOTION DETECTOR

A compact design that can be used with virtually any alarm system which has an input for N.C. or N.O. external sensor. Coverage is approximately 110 degree angle and up to 8 metres. Comes with detailed instructions.  
Cat. S15033 \$39.95



### MOUNTING BRACKET

For above Ultrasonic Alarm and features ball pivot for horizontal and vertical adjustment.  
Cat. S15042 \$11.95

# NOW IN STOCK, 'TALKING ELECTRONICS' KITS!

In addition to our 300+ EA/ETI kits, we now have over 50 'Talking Electronics' kits!

**BLACK JACK** Cat. K80001 \$11.00  
**CAPACITANCE METER** Cat. K80002 \$6.25  
**CLOCKS Incl. PCB** Cat. K80003 \$22.80  
**CLOCKS without PCB** Cat. K80004 \$19.50  
**COMBINATION LOCKS** Cat. K80005 \$7.50  
**COUNTER MODULE** Cat. K80006 \$21.70  
**7 SEGMENT DISPLAY** Cat. K80007 \$11.40  
**CUBE PUZZLE** Cat. K80008 \$17.90  
**DIGI CHASER** Cat. K80009 \$17.40  
**DIODE TESTER** Cat. K80010 \$3.30  
**KEN'S DUAL PSU.** Cat. K80011 \$11.80  
**DUAL TRACKING PSU.** Cat. K80012 \$18.90  
**8x8 DISPLAY** Cat. K80013 \$22.80  
**DUAL TRACKING PSU.** (without PCB) Cat. K80014 \$15.60  
**EGG TIMER** Cat. K80015 \$8.30  
**8W AMPLIFIER** Cat. K80016 \$9.70  
**EXPERIMENTER BOARD** Cat. K80017 \$14.30  
**EXPERIMETER DECK** Cat. K80018 \$17.55  
**HANGMAN with PC** Cat. K80019 \$12.50  
**FM BUGS** Cat. K80020 \$6.80  
**HANGMAN with no PC** Cat. K80021 \$9.20

**HEADLIGHT REMINDERS** Cat. K80022 \$12.90  
**IC POCKET RADIOS** Cat. K80023 \$10.80  
**LED DICE** Cat. K80024 \$9.05  
**LED ZEPLINS** Cat. K80025 \$7.85  
**LIGHT THE LED** Cat. K80026 \$4.60  
**LOGIC DESIGNER (with PC)** Cat. K80027 \$20.90  
**LOGIC PROBES** Cat. K80028 \$11.55  
**LOGIC DESIGNER (without PC)** Cat. K80029 \$17.60  
**LOTTO SELECTORS** Cat. K80030 \$16.50  
**MINI FREQUENCY COUNTER (no PC)** Cat. K80031 \$15.60  
**MINI MIXER** Cat. K80032 \$3.90  
**NOISE A TRON** Cat. K80033 \$5.30  
**MINI FREQUENCY COUNTER RED** Cat. K80034 \$18.90  
**MINI FREQUENCY GREEN SCREEN** Cat. K80035 \$22.10  
**MUSIC COLOUR** Cat. K80036 \$9.90  
**PHASER GUNS** Cat. K80037 \$7.20  
**PILL TIMER** Cat. K80038 \$7.90  
**POWER SUPPLY LAMP** Cat. K80039 \$6.50  
**S PRINTER INTERFACE** Cat. K80040 \$28.60

**PROGRAMMABLE COUNTER** Cat. K80041 \$11.80  
**AUTO RESET** Cat. K80042 \$9.70  
**QUICK DRAW** Cat. K80043 \$3.90  
**RAM STACKS** Cat. K80044 \$9.70  
**RELAY DRIVER BOARD** Cat. K80045 \$28.40  
**ROULED** Cat. K80046 \$8.50  
**SQUARE WAVE OSCILLATOR** Cat. K80047 \$4.70  
**STEREO MINI MIXER** Cat. K80048 \$23.10  
**STEREO PRE AMPS** Cat. K80049 \$13.20  
**SIMPLICITY AMPS** Cat. K80050 \$6.80  
**STEREO VU METERS (no PC)** Cat. K80051 \$10.70  
**TRAIN SIGNALS** Cat. K80052 \$7.70  
**STEREO VU METER (with PC)** Cat. K80053 \$14.00  
**TOUCH PUZZLE** Cat. K80054 \$6.25  
**TRAIN THROTTLE MK11** Cat. K80055 \$4.30  
**TREMOLO** Cat. K80056 \$3.80  
**TEC 1A** Cat. K80057 \$95.00  
**STAGE-1 KIT** Cat. K80058 \$89.95



### ELECTRIC FENCE

Mains or battery powered, this electric fence controller is both inexpensive and versatile. Based on an automotive ignition coil, it should prove an adequate deterrent to all manner of livestock. Additionally, its operation conforms to the relevant clauses of Australian Standard 3129. (EA Sept. '82)

82EF9 \$19.50



### ELECTRONIC MOUSETRAP

This clever electronic mousetrap disposes of mice instantly and mercifully without bait and resets itself automatically. They'll never get away with the cheese again! (ETI Aug '84)

Cat. ETI 1524 \$29.95



### 30 V/1 A FULLY PROTECTED POWER SUPPLY

The last power supply we did was the phenomenally popular ETI-131. This low cost supply features full protection, output variation from 0V to 30V and selectable current limit. Both voltage and current metering is provided. (ETI Dec '83).

ETI-162 \$49.50



### COMPUTER DRIVEN RADIO-TELETYPE TRANSCIEVER

Here's what you've all been asking for — a full transceiver system for a computer-driven radio teletype station. The software provides all the latest "whizz-bangs" like split-screen operation, automatically repeating test message, printer output and more. The hardware uses tried and proven techniques while designed to team with the popular Microbee tips are available on inter-facing the unit to other computers. (ETI Nov '84. ETI-755)  
Cat. K47550 \$139.00



### 1W AUDIO AMPLIFIER

A low cost, general-purpose, 1 watt audio amplifier, suitable for increasing your computers audio level, etc. (EA Nov '84)

\$9.95



### EFFECTS UNIT

An effects unit that can create phasing, flanging, echo, reverb and vibrato effects. (EA June '83).

83GA6 \$65.00



### INVERTER

This 12/240V inverter can be used to power mains appliances rated up to 40W, or to vary the speed of a turntable. As a bonus, it will also work backwards as a trickle charger for top up the battery when the power is on.

(EA May '82) \$49.50



### 12-230V DC-AC INVERTER INCLUDING TRANSFORMER 300 WATTS

This EA Inverter is capable of driving mains appliances rated up to 300VA and features voltage regulation and full over load protection. (EA June '87)

Normal Supply Voltage	12V DC
Output Voltage	see Table
Frequency	50Hz/22 000
Regulation	see Table
Maximum Load	300VA
Current Limiting	see Table

P & P \$10.00 Anywhere in Australia \$195.00



### PARABOLIC MICROPHONE

Build a low cost parabola, along with a high gain headphone amplifier to help when listening to those natural activities such as babbling brooks, singing birds or perhaps even more sinister noises. The current cost of components for this project is around \$15 including sales tax, but not the cost of batteries or headphones. (EA Nov. '83)

83MA11 \$15.00

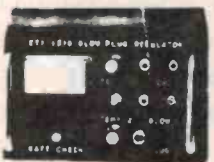

### MODEL ENGINE IGNITION SYSTEM

Get sure starts every time and no more glow plug burnouts on your model engines. (ETI June '83)

ETI-1516 \$41.50



### CAR IGNITION KILLER

Most car burglar alarms are easily circumvented, but not this cunning "Ignition Killer". This sneaky antitheft device uses a 555 timer to place an intermittent short circuit across the points. Until disabled by its hidden switch the circuit effectively makes the car undrivable — a sure deterrent to thieves! (EA Feb. '84)

84AU1 \$16.95  
(Our kit includes the box!)



### LOW OHMS METER

How many times have you cursed your Multimeter when you had to measure a low-value resistance? Well with the "Low Ohms Meter" you can solve those old problems and in fact measure resistance from 100 Ohms down to 0.005 Ohms. (ETI Nov. '81)

ETI-158 \$34.50



### VIDEO AMPLIFIER

Bothered by smeary colours, signal beats and RF interference on your computer display? Throw away that cheap and nasty RF modulator and use a direct video connection instead. It's much better! The Video Amplifier features adjustable gain and provides both normal and inverted outputs. Power is derived from a 12V DC plugback supply. (EA Aug. '83)

83VA8 \$15.00



### MOSFET POWER AMPLIFIER

Employing Hitachi Mosfets, this power amplifier features a 'no compromise' design, and is rated to deliver 150W RMS maximum and features extremely low harmonic, transient and intermodulation distortion. (ETI Jan. '81)

Cat. ETI 477 \$67.50

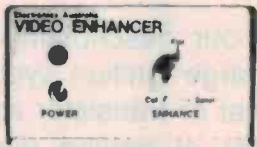

### VIDEO ENHANCER

Like tone controls in a hi-fi amplifier, touch up the signal with this Video Enhancer. (EA Oct. '83)

83VE10 \$35.00



### RADIOTELETYPE CONVERTER FOR THE MICROBEE

Have your computer print the latest news from the international shortwave news service. Just hook up this project between your shortwave receiver's audio output and the MicroBee parallel port. A simple bit of software does the decoding. Can be hooked up to other computers too.

(ETI Apr. '83) \$20.00



### MUSICOLOR IV

Add excitement to parties, card nights and discos with EAs Musicolor IV light show. This is the latest in the famous line of musicolors and it offers features such as four channel "color organ" plus four channel light chaser, front panel LED display, internal microphone, single sensitivity control plus opto-coupled switching for increased safety. (EA Aug. '81)

81MC8 \$84.00



### FUNCTION GENERATOR

This Function Generator with digital readout produces Sine, Triangle and Square waves over a frequency range from below 20Hz to above 160Hz with low distortion and good envelope stability. It has an inbuilt four-digit frequency counter for ease and accuracy of frequency setting. (EA April '82)

82AO3A/B \$84.50



### MOTORCYCLE INTERCOM OVER 300 SOLD!

Motorcycling is fun, but the conversation between rider and passenger is usually just not possible. But build this Intercom and you can converse with your passenger at any time while you are on the move. There are no "push-to-talk" buttons, adjustable volume and it's easy to build! (EA Feb. '84)

84MC2 \$45.00



### TRANSISTOR TESTER

Have you ever desoldered a suspect transistor, only to find that it checks OK? Troubleshooting exercises are often hindered by this type of false alarm, but many of them could be avoided with an "in-circuit" component tester, such as the EA Handy Tester. (EA Sept. '83)

83TT8 \$15.00

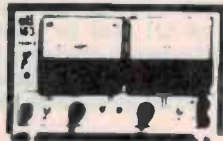

### LAB SUPPLY

Fully variable 0-40V current limited 0-5A supply with both voltage and current metering (two ranges: 0-0.5A/0-5A). This employs a conventional series-pass regulator, not a switchmode type with its attendant problems, but dissipation is reduced by a unique relay switching system switching between taps on the transformer secondary. (ETI May '83)

ETI-163 \$175.00



### SLIDE CROSS-FADER

Want to put on a really professional slide show? This slide cross-fader can provide smooth dissolves from one projector to another, initiate slide changing automatically from an in-built variable timer, and synchronise slide changes to pre-recorded commentary or music on a tape recorder. All this at a cost far less than comparable commercial units. (EA Nov. '81)

81SS11 \$85.00

### EPROM PROGRAMMER EP1



No need for a Micro with EA's great Eprom Programmer suitable for 2716/2758 Eproms. (EA Jan. '82)

82EP1 \$47.50  
With Textool Sockets \$59.95



### PHONE MINDER

Dubbed the Phone Minder, this handy gadget functions as both a bell extender and paging unit, or it can perform either function separately. (EA Feb. '84)

84TP2 \$24.00



### MICROBEE SERIAL-TO-PARALLEL INTERFACE

Most Microcomputers worth owning have an 'RS232' connector, or port, through which serial communications (Input/output) is conducted. It is a convention that, for listing on a printer, the BASIC LLIST or LPRINT command assumes a printer is connected to the RS232 port. Problem is, serial interface printers are more expensive than parallel 'Centronics' interface printers. Save money by building this interface. (ETI Jan. '84)

ETI-675 \$55.00



### DUAL TRACKING POWER SUPPLY

Built around positive and negative 3-Terminal Regulators, this versatile dual tracking Power Supply can provide voltages from ±1.3V to ±22V at currents up to 2A. In addition, the Supply features a fixed +5V 0.9A output and is completely protected against short circuits, overloads and thermal runaway. (EA March '82)

82PS2 \$87.50



### BIPOLAR PROM PROGRAMMER

Every digital workshop should have one! Can be used to program the popular fusible-link PROMS like the 74S188/288, 82S23 and 82S123 etc. (ETI June '83)

ETI-688 \$47.50

### ELECTRIC DUMMY LOAD

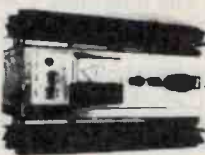

With this unit you can test power supplies at currents up to 15 Amps and Voltage up to 60 Volts. It can "sink" up to 200 Watts on a static test and you can modulate the load to perform dynamic tests. (ETI Oct. '80)

ETI-147 \$99.00

Errors and Omissions Excepted

# rie

Rod Irving Electronics

425 HIGH STREET,  
NORTHCOTE VICTORIA.  
Ph:(03)489 8866 489 8131  
48-50 A'BECKETT STREET,  
MELBOURNE VICTORIA.  
PH:(03)347 9251  
Mail Order and  
correspondance:  
P.O. Box 235  
NORTHCOTE 3070

Call in at either 2  
of our convenient-  
ly located stores:  
48-50 A'Beckett  
St., Melbourne  
425 High St.,  
Northcote.  
Or take advantage  
of our Mail  
Order Department.

Write to:

MAIL ORDER CENTRE  
ROD IRVING ELECTRONICS  
P.O. BOX 235  
NORTHCOTE 3070

or phone ...

MAIL ORDER  
HOT LINE



(03) 481 1436



POSTAGE RATES	
\$1-\$9.99	\$1.50
\$10-\$24.99	\$2.00
\$25-\$49.99	\$3.00
\$50-\$99.99	\$3.50
\$100-\$199	\$5.00
\$200-\$499	\$7.50
\$500 plus	\$10.00

Comet road freight is extra.



### 50V 5A LABORATORY POWER SUPPLY

New switchmode supply can deliver anywhere from three to 50V DC and currents of 5A at 35V or lower. Highly efficient design. (EA May, June '83)

83PS5 \$140.00



### ZENER TESTER

A simple low cost add-on for your multimeter. This checks zeners and reads out the zener voltage directly on your multimeter. It can also check LEDs and ordinary diodes. (ETI May '83)

ETI-164 \$9.50



# IMPROVED CDI

## — using shaped pulses

Last month we started our description of an improved CDI system. Capacitor discharge ignition systems are much more efficient than conventional or transistor assisted systems, and they're also much better at getting maximum performance from today's engines.

**Ian Thomas**

### Part 2

LAST MONTH this new pulse shaped capacitor discharge ignition system was introduced, sketching the background problems the systems have incurred up till now and detailing requirements for a successful CDI. Having dealt with such delicacies as cross firing, soaring temperatures and circuitry the next step is to build the device.

#### Construction

The CDI is constructed quite conventionally and I chose to build mine into an Eddystone diecast aluminium box 94 x 119 x 53 mm (Jaycar #HB5020). The all aluminium boxes are far better as they're stronger and make a useful heatsink for the power devices. The board layout nicely fits (that is only just!) in the lid of the box and that's where it's mounted. You can do your own artwork but it's a lot easier to buy it from ETI or you can buy a ready made board. If you decide to tape up your own remember that *very high currents flow around the inverter primary*. As much copper as possible must be left. Once the board is etched and drilled use it as a template to drill the four mounting holes in the lid of the box.

Next use the mica heatsink insulators provided to mark out the holes for the two power transistors. Drill out the four holes for each transistor and drill another to mount D10. It's hard to say what size holes to use as the mounting hardware varies but I recommend that about 4.5 to 5 mm be used to clear the transistor leads. The transistors should be mounted in the end of the box nearest the terminal pads where leads from the transistors attach to the board. Don't forget Q1's collector lead carries an average 8 amps when the inverter's running. Mount the transistors using heatsink grease and the mica spacers between the transistors and the lid.

Cut four pieces of insulating sleeving about 5 mm long and slip over the transistor leads (I used silicon rubber sleeving which

is to be preferred as it doesn't mind a bit of heat). This ensures that if a metal fragment falls into one of the holes it doesn't cause disaster. Next connect the emitter of Q2 to the base of Q1 and wire in R21 between the base and emitter of Q1. Diode D3 can be soldered between the terminal tag on the collector of Q1 and its emitter. Finally mount D10 using an insulating spacer and a *small amount of heatsink grease*, and assembly of the components on the heatsink is complete.

The next thing to do is to wind the two inductors. L1 is by far the most important and, as it must handle both very high currents and voltages some special materials are needed. The inductor is wound on a TDK type PQ32/20 core using H7C1 ferrite material. These cores are distributed in Australia by GEC who (praise be!) have a cash sale counter in their warehouse at 2 Giffnock Ave, North Ryde NSW. If you can't get there then I suppose you're at the mercy of the distributors. These cores are specifically designed for switching regulators and are surprisingly small for their performance. They come complete with a coil former that's essential. In the inverter core when it's running flat out there are expected losses of about 2 watts in the worst case so the interior of the coil gets a spot warmish. For this reason (amongst others) the bog standard PVC insulating tape just isn't good enough. The tape to use, which can be found in all industrial and commercial equipment, is polyester insulating tape. Normally you can't get the stuff from Jaycar and certainly not from the ubiquitous Richard. It's marketed in Australia by Beiersdorf (Australia) in North Ryde. They don't sell direct to the public but a phone call will tell all. Alternatively look in the 'Where to get it' section (Shoparound) at the back of this magazine. The stuff is TESA Type 4107 Polyester Electrical Tape and it's very handy to have around. I use it in almost all applications. Back to winding the coil.

The winding width available in the core is only 9 mm so if you've got insulating tape 12.7 mm wide (the usual size to be

stocked) you'll have to cut it down. The easiest way to do this is to lay down about 200 mm of tape on a piece of glass and trim one edge with a sharp blade and steel rule. Don't even try trimming it with scissors. If it sticks to itself it *cannot* be unstuck! Trim a few pieces of tape and leave them on the glass to be used when necessary.

The coil is wound with a layer of secondary then the complete primary then a second layer of secondary. Finally the base feedback and trigger power windings go on the outside. The secondary which goes on first consists of about four metres of 0.35 mm diameter wire. Cut two pieces of insulating sleeving (once again I used silicon rubber sleeving and here it's more important) each about 20 to 25 mm long and slip over the ends of the wire. The sleeving is to insulate the ends of the winding where they emerge from the coil to prevent any nasty flashovers. Push one piece right down on the wire as it isn't used until the end of the first half of the winding. Take the coil former and hold it so the pins point towards you and start the winding going *to the left* from the pin end of the former. Make sure that the silicon sleeving reaches to the terminal pins but not too much further and continues about a quarter turn into the coil.

Wind on wire tightly but don't allow it to ride over the previous turn. Every five turns or so push the wire hard down so the turns are tightly packed and neat. Wind on 24 turns and use the second piece of silicon sleeving to insulate the last quarter turn as the wire comes out of the top of the former. Take one of your pre-trimmed pieces of wire and cover the winding with two to three complete layers of tape. If any of the winding can be seen at all after you've taped it you'll have to redo it. A secondary to primary breakdown would be catastrophic. The final result at this stage should be a nice pretty coil with sleeved wires protruding from either end. Be super careful not to break the two metres of wire protruding from the top of the coil as this forms the other half of the secondary. Also



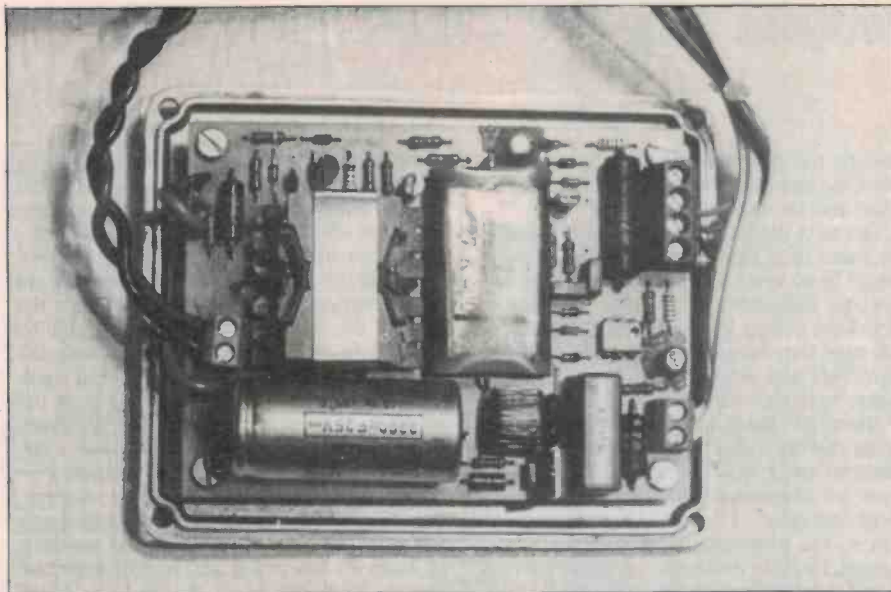

make sure that there is sufficient sleeving to cover the wire as it goes over the primary winding and back into the coil.

Next the primary has to go on. This consists of seven turns of 1.1 mm diameter wire tapped at three turns; 0.7 m is all that's needed. To start bend one end of the wire very sharply at right angles and *tin the end of the wire up to 7 mm from the bend*. This is so you don't have to tin the wire on the coil and risk damaging the insulation. Next hold the coil former as before and start the winding from the pin end of the coil going to the right: that is, the primary is wound in the opposite direction to the secondary. Wind on all seven turns tightly spaced and bend the end of the wire straight out the top. It *must* be exactly seven turns and they must be even and tightly packed (although if you use the right wire there's no way to loose pack them!). The final result here should be a neatly wound coil with the two ends on the *opposite side of the former to the secondary*. It helps to look at the board layout to see where you want to have the leads come out.

Next count up three turns from the bottom of the coil and scrape off the insulation with a sharp pointed blade. This is to make the tap for Q2's collector so make sure the winding goes around the coil three times exactly before coming out where you're scraping away the insulation. Be painfully careful not to damage the insulation but try to bare the copper in the groove between the turns so the soldered on tap doesn't make too big a bulge. The wire should be bare for about 5 mm in a strip 1 mm wide. Next tin the bared copper *being quick so as not to damage the insulating tape*; it's heat resistant but it has its limits! Take a piece of the wire used for the secondary about 50 mm long and tin its end for 5 mm. Lay the tinned end next to the tinned tap point so the two tinned areas lie next to each other and touch them with the soldering iron. The solder should flow to make a nice neat lap joint *with no dags or spikes of solder*. Any sharp points may damage the next insulating layer.

It's a good idea at this point to examine the joint under a magnifying glass as now

problems are easy to fix but later not so easy. Finally cover the primary with another two to three complete layers of tape. Once again you should be left with a nice smooth yellow coil former only this time you have two wires protruding from either end of both sides of the former. The tap should come out where the primary winding was started. If you want, now is a convenient time to terminate the tap as even if you've made a mistake in the direction of the windings the tap will go to the same place. Holding the former as you've been doing for all the windings the tap goes to the third pin from the end or the pin just to the left of the centre gap in the row of pins. Tin the tap to within 5 mm of the coil and wrap it once around the pin then solder it in place making sure it's pushed hard up against the body of the former. Don't stretch the wire tight as it comes out of the coil as this makes for an unreliable coil. Better to leave a little slack.

Next comes the second layer of the secondary. At this stage, even with the best efforts in the world, you'll have a few lumps in the tape you have to wind on. You probably won't be able to get another full 24 turns on. Not to worry — the exact turns ratio isn't all that critical. Wind the next layer from the top down so the silicon sleeving completely protects the secondary from the primary with once again nice, neat tightly packed turns. *Wind them in the same direction as you did the first half!!!* If you wound them the other way they would cancel the first half out and all you'd get out of the inverter is smoke! I only fitted 21 turns on the prototype but even less wouldn't matter too much. The main effect of far too few turns would be to shorten the rise time of the output pulse to the ignition coil. Try to squeeze on the full 45 turn total for both halves. When you've finished the secondary, cut another piece of sleeving and slip it over the end of the wire. Sleeve the last quarter turn and bring the end out the same side as the secondary was started. Cover the secondary with another three layers of insulating tape and it's complete. It's a good idea not to terminate the secondary onto the pins until testing is complete.

The feedback and trigger windings are the next step and if you've come this far they're a snip. As both windings are brought out to pins away from the centre gaps in the rows of pins it doesn't matter which way you wind them all that much but in case you have trouble getting the necessary test equipment I'll describe how to get them right.

Wind the feedback winding using the same wire as you used for the secondary. As there are 16 turns you'll need about 1.5 m. (I usually estimate lengths generously as it's easier to cut a bit off than join some on!) Wind the feedback winding in exactly the same way as you wound the primary, starting from the same point. You can leave a millimetre free at the bottom of the former as the winding won't (shouldn't) fill the whole former. As before take the winding out of the top of the former and cover it with tape, but here one or two layers are sufficient. If you're absolutely sure it was wound the same way as the primary you can now terminate it but I suggest you leave plenty of slack in case you have to reverse the winding. The start or pin end of the winding goes to the second pin from the left or the centre pin in the left hand bank of three. In the circuit layout it goes to ground so hold the former over the board to make sure you're right before soldering it on. The end away from the pins goes to the far right pin in the group on the primary side and is the end that connects to ZD1 and C3.

Finally you can wind on the trigger power winding. Use the same wire as before but this time only three turns are needed. First cover the feedback winding return with a small piece of tape. The enamel would probably be able to cop the voltages generated but it's best not to push your luck! Then wind on the three turns in the centre of the winding space exactly as you did for the feedback and primary windings and in the same direction. However, *the trigger power winding goes on the side of the coil where the secondary ends come out*. The start or pin end of the windings goes to the output ground or the far right pin in the output bank of six pins and the top or finish end

goes to the pin next to it and connects to D8. One last layer of tape to hold things in place and the coil is complete.

The next thing to do is test the coil and at the same time find the correct thickness of spacer to be used. The two halves of the ferrite core that surround the coil are made so they have no air gap between them but in this case they *must* have a precisely spaced gap. This gap is generated by using some spacer material with suitable properties cut to the right shape and placed between the cores before they are assembled. The material used isn't all that critical but it must be dimensionally stable and a very good insulator. I used Mylar draughting film in the prototype as this meets all requirements but there are probably dozens of other suitable materials. The total thickness needed is 0.5 mm with a tolerance of about 10 per cent.

The easiest way to make sure the thickness is correct is to test the inductor to make sure it's okay as this really is the bottom line. To test the inductor it's easiest to use the dump capacitor you've already bought. Connect it in parallel with the coil primary and cut small pieces of the film you intend to use that fit into the hole in the coil former.

Assemble the cores around the former and loosely hold them in place. Connect an audio oscillator across the parallel capacitor-inductor combination. The oscillator should have an output impedance of 600 ohms and if it's lower use a padding resistor. Use a CRO or DVM with an ac response going up to 50 kHz (if you're not sure dig out the specifications) and monitor the voltage across the resonant circuit. Adjust the frequency until you find the resonance. It should be at around 27 kHz. If it's less than 25 kHz then you need more spacer material and if it's more than 30 kHz you need less. Make sure the two core halves are held tightly together but only clamp them in the centres where there's spacer material; they are by no means unbreakable. Once you've got the spacer material right cut enough circular pieces for the centre leg of the core and equally long thin pieces for both ends. Assemble the core with all three legs having exactly the same thickness of spacing material. For your interest the prototype had four thicknesses of 0.13 mm thick draughting film.

Once the core is assembled and the core clamp in place the core is ready for final test. At this stage the top of the primary lead is still probably sticking straight up. Carefully bend it down so it will go into the hole in the board and tin it up to the height of the former pins. I used a dual beam CRO for final test as this is by far the easiest way to check everything. Once again tack the dump capacitor across the primary leads and drive the coil capacitor from a 600 ohm or more source. The resonance which should be very sharp, should be at around 27 kHz again. With the primary at resonance, monitor the other windings as fol-

lows to make sure they're correct. Using one probe from the CRO, earth the outer lead of the primary and monitor the inner lead that will connect to the collector of Q1. Using the other probe check that the primary tap has four sevenths of the voltage on it that appears at the end. Next earth the end of the feedback winding that will be earthed in the board and check that the 'hot' end is *in anti-phase* with the 'hot' (collector) end of the primary: that is, when the primary end swings positive the feedback winding swings negative and vice versa. The voltage on the feedback winding should be sixteen sevenths of the primary winding. The trigger winding should be tested exactly the same way. Earth the end that connects to earth on the board and monitor the end that connects to D8. It should be *in phase* and its voltage should be three sevenths of the primary voltage.

Finally check the secondary and this is the most important one (although if *any* winding is wrong it will stop the CDI from working). Earth the outer end of the secondary and monitor the inner end. Similarly the two voltages should be in phase and in this case the voltages should be in the ratio of 45/7. If this is okay then the secondary can be terminated on the former pins. The inner goes to the third pin from the left when you hold the coil with the pins towards you. It's the end that connects to the node of C2 and R4 so check it against the layout to make sure you've got the right pin. The other end of the secondary goes to the pin next to it on the other side of the centre gap — refer to the layout again. This completes the coil and it's ready to go into the board.

This brings us to L2. This is a toroidal coil wound on a Neosid 28-013-36/F9 core. The only one I could get was uncoated bare ferrite which was a damn nuisance as the ferrite is conductive. If you can get the varnished ones it'll save you a lot of fiddling around. I had to give the core several coats of varnish myself before I could use it.

I used the ubiquitous Richard's pressure pack clear acrylic spray. It seemed to work just fine. I held the core on a pair of tweezers as it's *very* important that the corners of the core be completely covered. After it's dried it has to be wound (boring!). The winding is about 60 turns of 0.2 mm wire which needs 2.2 metres of wire. Each turn must be carefully placed next to the turn before with no space left between the turns, but once again no turn lying over the turn before. Wrap each turn over the core tightly. It's easiest to start the winding in the centre so you don't have to thread so much wire through the core. If you can sucker someone into it, it helps to have a second person take the end of the wire after you thread it through the core and pull it away from you while you guide it through the core then hand the end back to you when you're ready.

When all 60 turns are wound on you should have a few millimetres of space be-

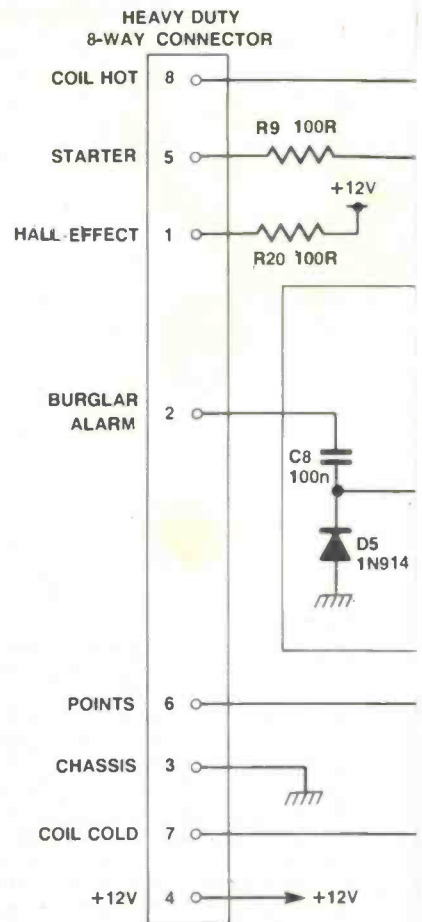

## PARTS LIST — ETI-342

Resistors..... all 1/2 W 5% unless noted	
R1.....	6k8
R2.....	2k2
R3.....	4k7
R4, R8.....	220k
R5, R16.....	5k6
R6.....	2k7
R7.....	390R
R9, R20.....	100R
R13.....	See text
R14.....	See text
R15.....	3R3 2W wirewound
R17.....	22R
R18.....	460R
R19.....	47R 2W wirewound
Inductors	
L1.....	Wound on TDK core type PQ32/20 H7C1 ferrite (from GEC — see construction)
L2.....	Wound on Neosid toroid type 28-013-36/F9 (preferably coated — see construction)
Capacitors	
C1.....	2200µ/25 VW electro (see construction)
C2.....	2µ7 400 V foil film (see construction)
C3.....	100p/100 V ceramic plate
C4.....	1µ/25VW electro (rad)
C5.....	470p/500 V 10% cer. plate
C6.....	150n/250 Vac metal foil (see text)
C7.....	2µ/25 VW electro (rad)
C10.....	10n/63 V met. poly.
C11.....	47n/63 V met. poly.

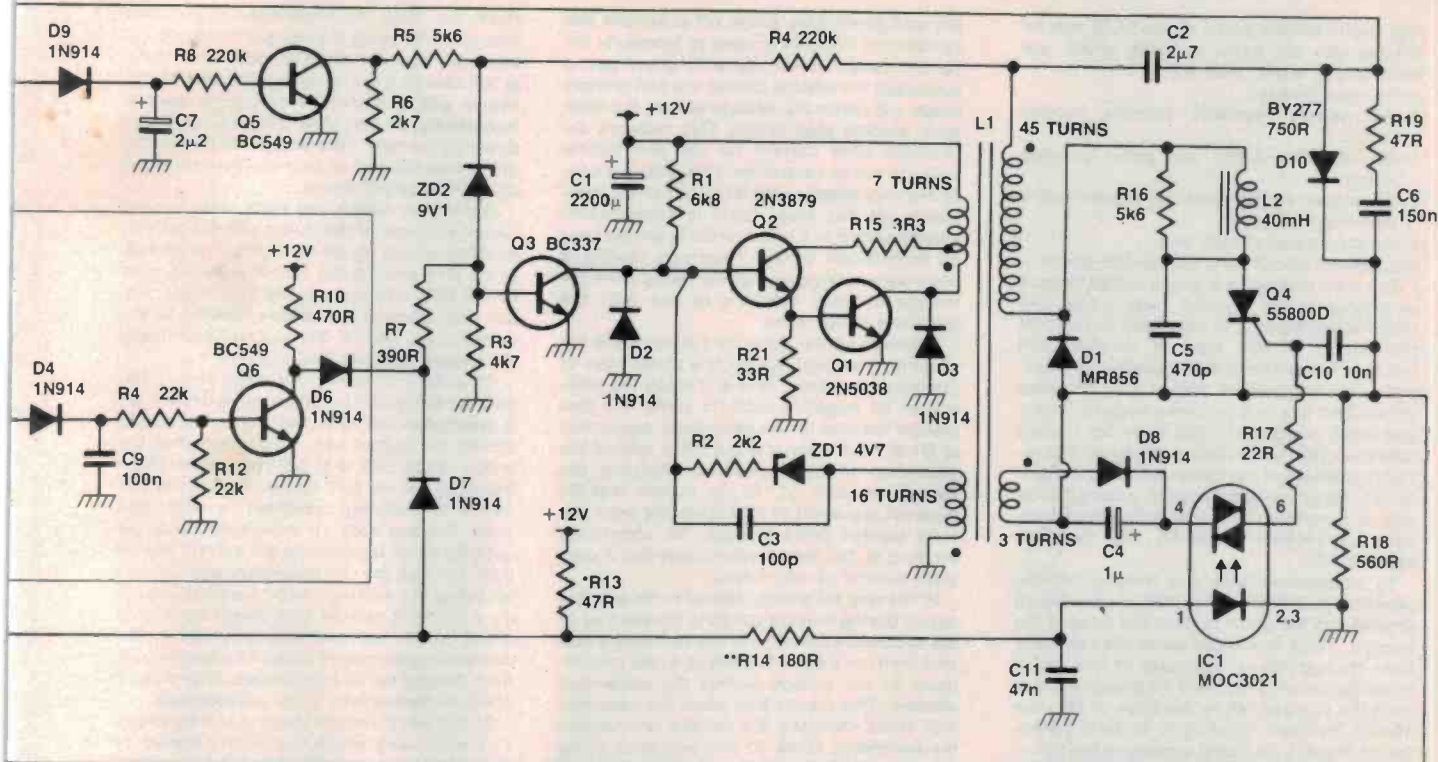

FOR HALL EFFECT SENSOR:  
 \*R13=300R/1W  
 \*\*R14=22R

### NOTES & ERRATA

Feb. '85, CDI p.63: The circuit diagram for this project shown last month had two errors: R8 should have been 220k not 220R and Q4 should have been listed as 55800D not S5800D.

Q1, Q2 REAR VIEW

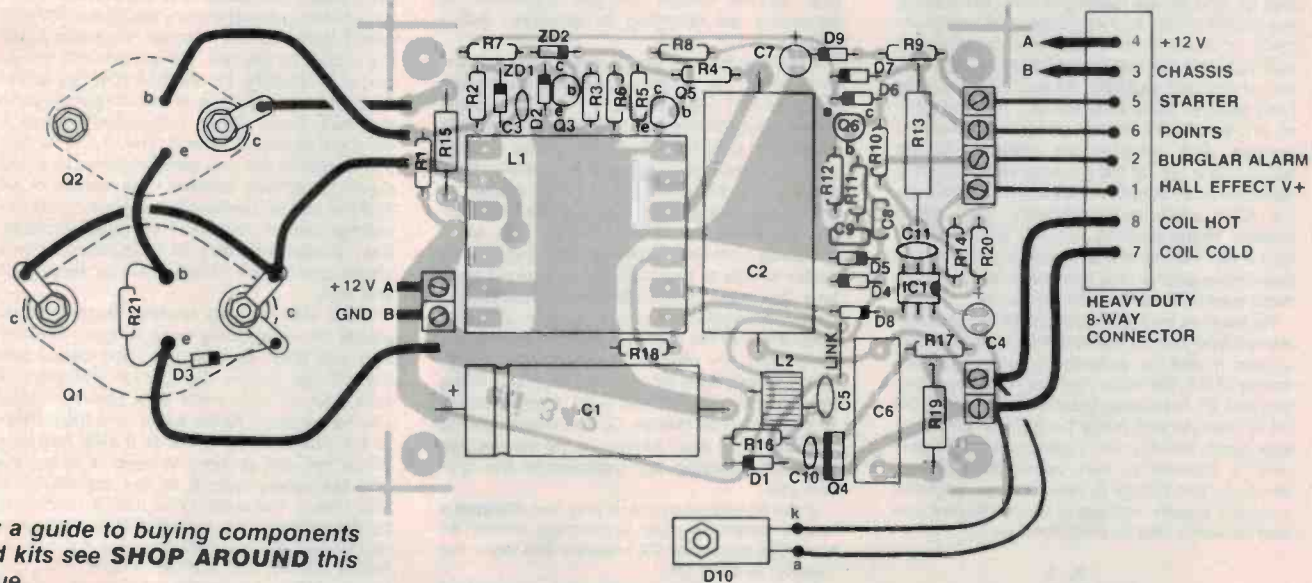

For a guide to buying components and kits see **SHOP AROUND** this issue.

#### Semiconductors

- D1 ..... MR856 (Motorola)
- D2, 3, 7, 8, 9 ..... 1N914 or similar
- ZD1 ..... BZX79/C9V1 zener
- D10 ..... BY277/750R or equiv.
- ZD2 ..... BZX79 C4V7 zener
- Q1 ..... 2N5038
- Q2 ..... 2N3879
- Q3 ..... BC337

- Q4 ..... 55800D SCR (RCA) (see text)
- Q5 ..... BC549 or sim.
- IC1 ..... MOC3021 (Motorola)

#### Miscellaneous

ETI-342 pc board; diecast aluminum box 120 x 95 x 56 mm; heavy-duty 8-way connectors — panel socket, 2 x cord-type plugs; nuts, bolts, pcb mounting spacers etc.

#### Optional (burglar alarm option)

- R10 ..... 470R 0.4 W 5%
- R11, 12 ..... 22k 0.4W 5%
- C8, 9 ..... 100n/63 V met. poly
- D4, D5, D6 ..... 1N914 or similar
- Q6 ..... BC549 or similar

Price estimate: \$45

The circuit for the pulse shaped CDI can be divided into six basic sections which are described in order. They are:

- 1) the main inverter;
- 2) the voltage regulator inverter control circuit;
- 3) the capacitor dump and pulse shaping circuit;
- 4) the trigger circuit (both for points and a Hall effect sensor);
- 5) the start boost circuit; and
- 6) a lock-off circuit for a car burglar alarm.

The main inverter is a single ended flyback or ringing choke inverter, which has two major advantages: It is very easy to regulate the output of this type of inverter, and this type of inverter is also completely insensitive to the load it drives. In the case of the CDI it has to drive into a large capacitor and must charge it to 300 volts for normal operation (400 volts during starting). The inverter consists of the main switching transistor Q1, the driver transistor Q2, a transformer with a precisely controlled primary inductance L1, rectifier diode D1 and the load capacitor C2.

To understand how the inverter works, consider that the base of Q2 is shorted to ground and the short is removed to start the inverter. (This is exactly what the regulator does through Q3 — but more of this later.) When the short is removed R1 bleeds current from the positive rail to the base of Q2. The 16-turn feedback winding is at earth potential, as there is no signal applied to the transformer, but the zener diode ZD1 is reverse biased and will allow the base of Q2 to go up to 4.7 volts before it breaks down.

When the base of Q2 reaches about 0.8 volts, Q2 starts to turn on and applies the full supply voltage across the primary winding. The polarity of the feedback winding is such that D4 and R2 are taken positive, increasing the drive for Q2. At this stage (100 nanoseconds or so after the turn-on commenced) both Q1 and Q2 are turned hard on. ZD1 is forward biased and both R1 and R2 are giving base drive to Q2 and hence Q1. The collector of Q1 is 100 mV above ground (saturation voltage) and because the collector of Q2 feeds into a tap on the primary winding, Q2's collector is at about 4 volts for a 13 volt supply. Q2's collector could have been taken directly to the positive rail, but by feeding it into a tap on the primary winding 2/3 of the base drive power that otherwise would have been wasted is recovered and used.

As soon as turn-on is complete the secondary winding has 45/7 times the supply voltage across it and its polarity is such that the anode of D1, the main rectifier, is taken positive and D1 is reverse biased. The dump SCR Q4 is also off and plays no part in the inversion cycle. For the next 20 microseconds current is allowed to run up in the primary winding. The runup is linear as an (almost) constant supply voltage is across a very low loss inductor and is described by

$$I_{pk} = \frac{V_{cc} t}{L}$$

where  $I_{pk}$  is the maximum current,  
 $V_{cc}$  is the supply voltage,  
 $t$  is the runup time and  
 $L$  is the inductance.

After 20 microseconds the current has reached about 20 amps and R1 and R2 aren't able to supply sufficient base current to hold Q2 and Q1 in saturation. The beta of Q1 rap-

idly and predictably drops off at around this current and this fact is used to terminate the current ramp. As Q1 starts to come out of saturation the voltage across the coil primary drops and hence the voltage across the feedback winding also drops. This reduces the available base current for Q2 and further pulls Q1 out of saturation. This process continues very rapidly until Q1 is turned off completely. At this stage there is considerable energy stored in L1 and as Q1 is turned hard off its collector voltage rises very rapidly. If there were nothing to stop the rising collector voltage it would continue to rise until the transistor broke down.

However, as the collector voltage rises the secondary voltage, which is a direct ratio of the primary voltage, falls and takes the cathode of D1 negative until D1 turns on. This clamps the end of the secondary connected to D1 at -0.7 volts and the other end of the secondary is taken positive, charging the output capacitor C2. At the instant that D1 turns on, a current of 7/45 times the peak primary current flows through the secondary winding as the transformer must see a constant number of amp turns.

In this way the energy stored in the primary circuit during current runup is transferred to the secondary circuit and the secondary current then runs down to zero at a rate proportional to the voltage across the secondary winding. This means that when the capacitor first starts charging the current rundown in the secondary takes 30 microseconds or so but when it is fully charged it only takes four or five microseconds. This means that the frequency of oscillation of the inverter increases as the capacitor charges.

As a matter of casual interest exactly this sort of circuit is used in photographic flashguns and that is why the faint whistle you hear as the strobe charges increases in frequency as charging progresses; but I digress.

While the current in the secondary is running down, the feedback winding holds the anode of ZD1 negative and hence the base of Q2 negative through R2. D2 acts as a clamp to prevent Q2's base from being taken too far negative and being broken down (which isn't destructive, but does leave stored charge in Q2's base and prevents it operating correctly). As soon as all the energy has been removed from the secondary winding, the inverter is able to return to its original off state and the main transistors are immediately turned on again to repeat the cycle. The current runup in the primary and rundown in the secondary are rapidly repeated with charge being forced onto C2 with each cycle until the desired charge is stored in C2. Every time D1 is turned on to charge C2 the output clamp diode D10 is also turned on so no voltage from the charging ever appears on the ignition coil.

If the inversion process was not stopped it would continue until something broke, so after the capacitor C2 reaches 300 volts the inverter is shut off.

Inverter control is performed by resistors R4, R5, R6, zener diode ZD2 and transistor Q3. R4 forms a potential divider with R5 and R6 to divide the output voltage down to about 10 volts at full charge. At this voltage ZD2 starts to break down and provide base current for Q3. When Q3 starts to turn on, it robs the main inverter of base drive and prevents oscillation. Thus the inverter charges C2 until ZD2's zener voltage is reached, then it steps until R4 bleeds enough charge from C2 to

allow the cycle to commence again. One charge-dump cycle is sufficient to top up the capacitor again so when the inverter is idling at full charge it only grows a few tens of millamps and the inverter core can be heard to buzz faintly. R7 may also turn on Q3 and shut down the inverter. This is used for the burglar alarm lock-off and to shut the inverter down during the output dump.

The trigger circuit and main output dump circuit consists of the dump SCR Q4 with its snubber circuit (great word, that) consisting of L2, R16 and C5; the output pulse shaping circuit D10, R19 and C6; the SCR trigger circuit consisting of the tertiary winding on the transformer, D8, C4, IC1 and R17 and finally the trigger resistors R13 and R14.

Consider first the output dump circuit. Before the dump and resultant spark occurs, C2 is charged to 300 volts and there is zero volts across the output coil. This means that the anode of the SCR is at 300 volts. When Q4 is triggered on via R17 (more of this later) its anode immediately collapses to near zero volts. For the next 10 microseconds or so nothing much happens as the current slowly rises through the coil secondary and L2, with L2 being the limiting factor. As L2 is wound on a toroid it cannot take much more than about 50 mA before it saturates and its inductance collapses to about 10 microhenries from its original 40 millihenries. After this L2 plays no further part in the proceedings.

At this point current starts to rapidly rise in L1's secondary which has an inductance of about 500 microhenries. When L2 saturates and drops from sight the SCR end of L1's secondary is also clamped to ground. Now the output to the coil also starts to go negative and D10 is turned off. The ignition coil itself is of such a large inductance that it can be effectively ignored at this stage. Also the main dump capacitor may be considered to be a battery which merely applies a 300 volt offset between the inverter secondary and the output to the coil. We are left with the inverter secondary, C6 and R19 in series and to form the leading edge of the output pulse to the coil these three components form a damped resonant circuit. The result is that the output to the coil goes negative in a precisely controlled manner. The values of C6 and the coil secondary inductance result in a voltage rate of rise (fall? the pulse is negative) of approximately 30 volts/microsecond. This figure can be varied at will by varying C6 and R19.

Once the damped leading edge is completed the main dump capacitor and the ignition coil form another resonant circuit and the voltage across the ignition coil primary falls back to zero volts as a (more or less) cosine function. At the same time the current in the coil primary rises as a sine function. While the coil primary voltage is rising the coil secondary output to the distributor is also rising. The output rise time is controlled by the primary rise time and also secondary stray capacitances and so does not exactly follow the primary. It rises until the plug gap breaks down, when the voltage almost instantly collapses to about 1000 volts. It is this extremely fast voltage collapse that causes most of the radio interference. Both the coil primary and secondary voltages are shown in Figure 7(b). When the plug gap breaks down it reflects a changed load into the primary side and effectively reduces the primary inductance which is visible in the photo.

After plug breakdown the current in both the primary and secondary continues to rise

until the voltage across the coil primary reaches zero when the current in both the primary and secondary is at a maximum. As the coil primary is resonating with C2 the voltage across the coil attempts to change polarity but the clamp diode D10 prevents this and when the first quarter cycle of the resonance is completed D10 shorts out the coil primary. At this stage all the energy stored in C2 has been transferred to the coil and D10 makes sure that it stays there.

At this stage the CDI apart from D10 has completed its job. The current trapped in the coil decays away to zero with most of the energy going into the spark gap in the secondary circuit. The primary winding resistance and diode voltage drop also absorb some of the energy, but most of it goes where it's wanted. The overall effect of D10 is to lengthen the spark, exactly what is needed with lean and turbulent mixtures in modern engines. The turbulence in the combustion chamber extinguishes the arc then the coil secondary voltage immediately rises and strikes a new arc as an inductor carrying current will not allow itself to be open circuited (or not without a fight).

The inductor L2, resistor R16 and capacitor C5 are there to protect the SCR from the very rapid changing voltages that appear on the inverter secondary when the inverter is charging. When C2 is nearly charged the side of the inverter connected to it is held at a steady 300 volts. This means that when Q1 is on, the cathode of D1 is at  $300 + 45/7 V_{cc}$ . When Q1 turns off, the cathode of D1 immediately goes to slightly below ground and when all the energy is removed from the inverter coil the voltage equally rapidly goes back to  $300 + 45/7 V_{cc}$  (see Figure 7(c)).

All SCR's have a maximum rate of rise specified for off state voltage and if this rate of rise is exceeded then the SCR will turn on. This is because there are internal capacitances within the bulk of the SCR that allow current to flow and part of this current flows in the gate circuit of the SCR. As the SCR cannot distinguish between these capacitive currents and true trigger currents, the SCR

will turn on. C10 is placed across the gate of the SCR to try to help but its effectiveness is limited by bulk effects within the SCR. The SCR chosen has a very high  $dV/dt$  rating (it's chosen for exactly that) but some external control is still needed. This is what the LCR network is for.

When the SCR is off only a very small current flows through L2 and R16; just enough to charge C5. R16 critically damps the resonance of L2 and C5 so no ringing occurs and the resultant waveform is shown in Figure 7(c) along with the coil secondary voltage before  $dV/dt$  limiting. You can see the rate of change of voltage is kept down to 100 V/microsecond — exactly the required maximum. As already discussed when the SCR is triggered on, L2 very quickly has too much current flowing through it and saturates.

The trigger circuit for the SCR derives its power from a tertiary winding on the inverter coil. This is because the inverter is capable of operating down to a supply voltage of 2 volts and this is not sufficient to trigger the SCR reliably. When the dump capacitor is fully charged, D8 charges C4 to about 20 volts. It's one of the nice features that when one output of a flyback inverter is regulated, all the other outputs are also regulated. This means that the trigger current for the SCR is always set at the optimum 1 amp peak.

The current is switched to the SCR from the capacitor via the optocoupler IC1. Since an optocoupler is used the whole secondary/dump circuit can be and is floated from the main ground of the system. This is done so that if the full supply voltage is applied to the output to the coil, D10 isn't destroyed. R18 connects the output ground to the main ground so the regulation network has a reference voltage to work to.

As the CDI may be operated from either the conventional points or a Hall effect sensor two options exist. For points, R13 is a 47 ohm 5 watt resistor and R14 is a 180 ohm resistor. When the points are closed the optocoupler input is off and D7 has no bias across it. Thus the inverter is enabled to charge C2 and no trigger current is released to the SCR. When

the points open D7 holds the inverter off and at the same time the input LED of IC1 is turned on. This triggers the triac side of the optocoupler and discharges C4 into the SCR gate. From here on until the points stay open long enough to recharge C2 and hence C4, no trigger current is available so contact bounce is eliminated.

For the Hall effect option R13 is changed to a 300 ohm 1 watt resistor and R14 becomes a 22 ohm resistor. The Siemens HKZ101 sensor can only switch 40 mA and all of this is needed to trigger the optocoupler; hence R14 is small. As a matter of interest the points option will operate down to 2 volts supply but the Hall effect option only works down to 4.5 volts due to limitations in the sensor itself.

When starting the engine it's nice to be able to increase the spark energy to give more reliable results. The only thing controlling the output voltage is the regulator circuit already discussed. A start signal is taken into the CDI and during engine cranking charges C7 to the supply rail through D9 and R9. This turns on transistor Q5 and shorts out part of the regulator potential divider. Thus the output must rise to 400 volts or more before the inverter is shut down. C7 ensures that the boosted voltage is maintained for a few seconds after the engine catches, before slowly decaying back to the operating voltage.

The final refinement in the circuit is a lock-off circuit to be controlled by a car burglar alarm. Since simply having a control line that had to be connected to ground or  $V_{cc}$  wouldn't slow up a competent thief, this circuit requires an ac signal to enable the inverter. The signal is capacitively coupled in via C8 and then rectified by diodes D4 and D5 to provide a dc signal to turn on Q6. When Q6 is on, D6 is reverse biased and enables the inverter but if Q6 is off then R10 and D6 hold the inverter off.

If you don't want the burglar alarm feature, the best approach is to simply leave out D6, R10, Q6 and all of the other parts connected to Q6's base. The burglar alarm input (2) can then be ignored.

tween the two ends of the winding. This is deliberate as each winding has only a few volts difference from the turn next to it but the two ends have the full 400 volts or so across them. When the core is completely wound give it a few more coats of the acrylic spray to insulate, hold down the winding and L2's complete.

Now comes the easy bit — assembly of the board. All the components are perfectly straightforward. Make absolutely sure that all the diodes go in the right way and also the electrolytic capacitors. C1, the main supply capacitor is particularly critical as it sees very high ripple currents when the inverter is running at full power. Your elskungo cheap capacitors probably aren't good enough and certainly aren't good enough if you insist on mounting the CDI under the bonnet of the car. I used a Rifa PEG 123 capacitor which is just okay but if it's to go in hot places a Rifa PEG 124 would be better. Whatever you use try to be sure it'll tolerate intermittent ripple currents of about 5 amps at 25 kHz.

The big electrolytic needs a little care in mounting also. Cars are prone to high vibration and heavy components need more than the support given by the two leads. When commercial equipment is tested one of its

tests is to place it on a vibration table and apply a swept sine wave to the table while mounting the device under test in various orientations. When mechanical resonances occur it really is dramatic. What appears to be a rigidly mounted component suddenly starts to move tens of millimetres and will easily break the leads.

In the case of the big electrolytic this is easily fixed by using double sided foam sticky tape that can be bought from any hardware store. I bought mine from BBC and it was called "Permastik Double Mounts". Cut a piece about 10 mm x 40 mm and stick it to the side of the capacitor. Then mount the capacitor on the board so the foam is sandwiched between the capacitor and the board. This will nicely damp out any mechanical resonance.

The toroidal inductor L2 *must absolutely* be stuck down to the board. I used generous quantities of silicone glue (e.g. "Silastic"). The same can be said for the two small electrolytics C4 and C7. As a nicety I used screw terminals for all the leads that go to the outside world from the CDI and the board layout leaves space for them. You need two 2-way terminals (Jaycar #HM3205) and one 4-way terminal (Jaycar #HM3207).

The board is laid out so the leads that

connect the inverter to its transistors can be made as short as possible and the leads form a sort of hinge to allow both sides of the board to be worked on. This means that the two leads from the output to the coil to D10 should be looped as shown in the photograph on page 73. The collector of Q1 should be connected to the board with enormously thick wire — here more is definitely better. Also if you look carefully at the picture you'll see that there is a lead connecting the two mounting screws of Q1. This is because the screws have a noticeable resistance (they're plated brass).

The board is mounted on four half-inch (oops! sorry 12.7 mm) spacers and in the prototype I didn't bother to earth the box at all. After you've connected all the wires between the board and transistors and diode on the heatsink, the board can be mounted on its spacers and the beast is almost ready to stoke up.

The one thing the CDI doesn't particularly like driving into is an open circuit. It doesn't damage anything but after triggering things tend to stay at high voltages for a long time. Better to go and pull the coil out of your car for testing. Connect the '+' terminal of the coil to the 'hot' output, the '-' to the earthy output and a suitable power

supply to the input. If you intend to use the burglar alarm option and have assembled it up it'll be necessary to temporarily short Q6's collector to ground or nothing will work. Alternatively you could put a high level audio tone of about 5 kHz into the alarm lock-off input and check that the lock-off works okay. (Q6's collector goes to ground.)

With the points input open circuit the inverter is shut off so the CDI should only draw a tiny amount of current. However when the points input is taken to ground the inverter recharges C2 and for a few milliseconds draws 5 or 6 amps and after that draws very little. R13 is only 47 ohms though and draws about a quarter amp (to keep the points clean). After charging, the inverter cycles every 25 milliseconds or so and if you listen carefully you should be able to hear a faint buzz. If you measure the voltage across C2 you should get 300 volts dc. Be careful with the probes as if you short the dump capacitor to anything else it makes for a loud bang and flash. The next test is to take the 'start' input to the positive rail. The buzz from the inverter should increase in frequency and the voltage across C2 should rise to 400 volts. Finally open circuit the points input and the CDI should trigger.

To make life a little easier it's a good idea to arrange a spark gap for the coil secondary about 5 mm long. When you're doing this, *make sure the CDI is disconnected from the power.* Take about 400 mm of the wire you used to wind your inverter coil secondary and crumple it into a ball with about 50 mm sticking out of it. Stuff the ball into the coil output and bend the wire so it points at the earthy primary terminal. Then when the CDI is running a nice fat spark should jump across the gap you've made.

If you've used the Hall effect sensor option then connect the sensor up with the positive lead (the red one) to R20 and the negative one (the black one) to ground. For this test R13 should be 300 ohms and R14 22 ohms. Connect the sensor output to the points input and test the inverter as before except that the CDI is triggered by flicking a screwdriver blade through the slot in the sensor.

Finally you can vary the supply voltage to the CDI and verify that it still works for the full range. The prototype worked just fine from 25 volts in (the maximum allowed for C1) to just on 2 volts in with the points option. For the Hall effect option it wouldn't trigger reliably for less than 4 volts but this was expected.

If all is well you can wire up the connector in the side of the box and install the CDI in your car. I used an 8-way connector and arranged things so that if the CDI failed the cable connecting the CDI to the car could be removed from the CDI and a jumper plug inserted in its place. As the CDI does not mind having capacitance across its output I used RG58C/U coaxial cable to connect the CDI to the coil. The outer was connected to the earthy side of the output and

the inner conductor to the hot side. This screened the output from the radio as the CDI was mounted under the dash. Since long cables can be used with this CDI there is absolutely no reason to put the CDI under the bonnet so have some sympathy for the electronics and put it somewhere cool. At a pinch it could even be placed in the boot so long as you used very thick power leads.

After installing the CDI there's no reason to do anything with the plug gaps and in fact it's a good idea not to. In the event that the CDI should fail you want to be able to quickly change back to the old system. It may seem a little negative to talk about failures but they do happen. Equipment built by home hobbyists is perhaps a little more prone to failure than commercial equipment mostly because the hobbyist doesn't have access to fancy test equipment and he has little control over the quality of the components he buys.

I can report that the CDI when installed in my V8 powered car gave absolutely no trouble with cross firing and gave all the improvements that electronic ignition is supposed to. I had some time ago changed the carbon filled resistive leads for copper ones so this change wasn't necessary in my case but if you still have the resistive leads it'd be a good idea to change to the metal filled ones. As you can see from the picture of the pulse shaped CDI secondary voltage and current (Figure 7(d)) a secondary current of about 70 mA flows and, as the typical resistive lead resistance is about 20 k a voltage drop of about 1.4 kV is to be expected. You may or may not choose to accept this loss but the CDI will work just as well in either case. The spark duration will be reduced if the resistive leads are left in.

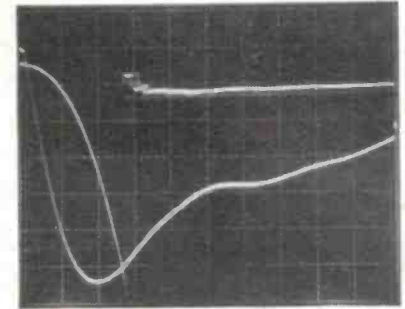

Figure 7(b). Coil primary (lower) and secondary voltage for the new CDI. Time 10  $\mu$ s/div, prim 50 V/div, sec 2 kV/div.

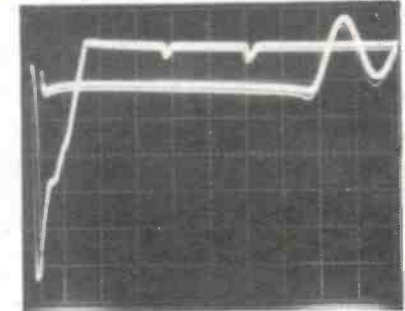

Figure 7(c). As above, but with 100  $\mu$ s/div to show arc duration.

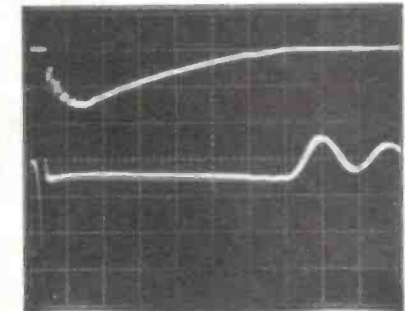
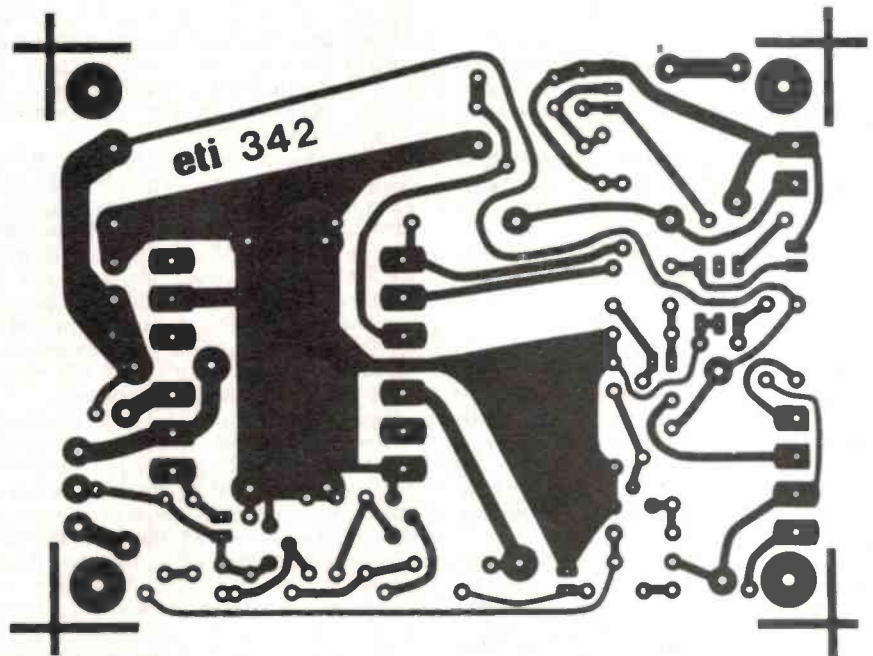

Figure 7(d). Coil secondary current (top, 50 mA/div) and voltage (bottom, 2 kV/div).



# THE BRILLIANT SERIES 5000

STILL GOING STRONG  
INDIVIDUAL COMPONENTS TO MAKE UP A SUPERB HI-FI SYSTEM.

By directly importing and a more technically orientated organisation, ROD IRVING ELECTRONICS can bring you these products at lower prices than their competitors. Enjoy the many other advantages of RIE Series 5000 kits such as "Super Finish" front panels at no extra cost, top quality components supplied throughout. Over 1,000 Sold.

For those who haven't that time and want a quality hi-fi, we also sell the Series 5000 kits Assembled and Tested.



## POWER AMPLIFIER

WHY YOU SHOULD BUY A "ROD IRVING ELECTRONICS" SERIES 5000 POWER AMPLIFIER.

- ★ 1% Metal Film resistors are used where possible.
  - ★ Aluminium case as per the original article.
  - ★ All components are top quality.
  - ★ Over 1000 of these kits now sold.
  - ★ Super Finish front panel supplied at no extra cost.
- Please note that the "Superb Quality" Heatsink for the Power Amplifier was designed and developed by ROD IRVING ELECTRONICS and is being supplied to other kit suppliers.

**SPECIFICATIONS:** 150 W RMS into 4 ohms  
**POWER OUTPUT:** 100 W RMS into 8 ohms (±5% V SUPPLY)  
**FREQUENCY RESPONSE:** 8 Hz to 20 KHz, ±0.4 dB 2 Hz to 65 KHz, ±0.3 dB. NOTE: These figures are determined solely by passive filters.  
**INPUT SENSITIVITY:** 1 V RMS for 100 W output.  
**HUM:** 100 dB below full output (flat).  
**NOISE:** 116 dB below full output (flat, 20 KHz bandwidth)  
**2nd HARMONIC DISTORTION:** <0.001% at 1 KHz; 10.0007% on Prototypes) at 100 W output using a 350 V SUPPLY rated at 4A continuous. <0.003% at 10 KHz and 100 W.  
**3rd HARMONIC DISTORTION:** <0.0003% for all frequencies less than 10 KHz and all powers below 60 W.  
**TOTAL HARMONIC DISTORTION:** Determined by 2nd Harmonic Distortion (see above).  
**INTERMODULATION DISTORTION:** 0.003% at 100 W, 150 Hz and 7 KHz mixed 4:1.  
**STABILITY:** Unconditional.

Cat. K4471 Normally \$339, Special Price \$309  
 Packing and Post \$10 Assembled & Tested \$499



## PREAMPLIFIER

THE ADVANTAGES OF BUYING A "ROD IRVING ELECTRONICS" SERIES 5000 PREAMPLIFIER KIT ARE:

- ★ 1% Metal Film Resistors are supplied.
  - ★ 14 Metres of Low Capacitance Shielded Cable are supplied (a bit extra in case of mistakes).
  - ★ English "Lorlin" switches are supplied (no substitutes here).
  - ★ Specially imported black anodised aluminium knobs.
- Available Assembled and Tested. (We believe that dollar for dollar there is not a commercial unit available that sounds as good.)

**SPECIFICATIONS:**  
**FREQUENCY RESPONSE:** High level input: 15 Hz-130 KHz, ±0. -1 dB Low Level Input - conforms to IRIIA equalisation, ±0.2 dB  
**DISTORTION:** 1 KHz; <0.003% on all inputs (limit of resolution on measuring equipment due to noise limitation).  
**S/N NOISE:** High Level input, master full, with respect to 300 mV input signal at full output (1.2V) >92 dB flat >100 dB A-weighted. MM input, master full, with respect to full output (1.2V) at 5 mV input. 50 ohms source resistance connected: >86 dB flat; 52 dB A-weighted MC input, master full, with respect to full output (1.2V) and 200 uV input signal >71 dB flat >75 dB A-weighted.

Cat. K44791 Normally \$299, Special Price \$269  
 Packing and Post \$10 Assembled & Tested \$599



## THIRD OCTAVE GRAPHIC EQUALIZER

**SPECIFICATIONS:**  
**BANDS:** 28 Bands from 31.5 Hz to 16 KHz.  
**NOISE:** <0.008 mV, sliders at 0, gain at 0 (-102 dB0).  
**20 KHz BANDWIDTH DISTORTION:** 0.007% at 300 mV signal, sliders at 0, gain at 0; maximum 0.01%, sliders at minimum.  
**FREQUENCY RESPONSE:** 12 Hz-105 KHz, ±0. -1 dB, all controls flat.  
**BOOST AND CUT:** 14 dB.

1 Unit...\$199  
 Cat. K44590 2 Units...\$379

PACKING AND POSTAGE \$10

## SERIES 4000 SPEAKERS

- 8 Speakers On ..... \$295
- 8 Speakers with Crossovers ..... \$499
- Speaker Boxes (assembled with grill and speaker cutout) ..... \$299
- Crossover Kits ..... \$199
- Complete kit of parts (speakers, crossovers, screws, innerband boxes.) ..... \$799
- Assembled, tested and ready to hook up to your system ..... \$899

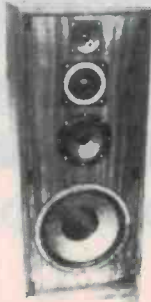

Errors and Omissions Excepted

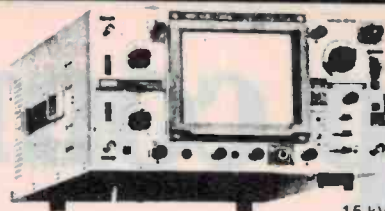

MODEL OS-645,  
15 kV, 45 MHz, 1 mV/div.

## "RITRON" DUAL TRACE OSCILLOSCOPES

- ★ LOW PRICE ★ HIGH QUALITY ★ EX STOCK
- ★ 12 MONTHS WARRANTY ★ ON DISPLAY ★
- ★ WIDE FREQUENCY BANDWIDTH: (70 MHz-6 dB)
- ★ OPTIONAL SENSITIVITY: All steps of vertical deflection factors are multiplied 5 times for the highest sensitivity of 1 mV/div; 10 MHz.
- ★ DELAYED TRIGGER SWEEP: Any point of the waveform is addressed as a triggering start. So, any waveforms can be substantially and brightly magnified, thanks to the 5 kV bright CRT.
- ★ EXTREMELY BRIGHT DISPLAY: The metal back CRT (PDA) provides brightest trace display.
- ★ DELAY LINE: (for BS-625): Approximately 20 nsec before triggering point is displayed for real analysis of rise times.
- ★ SCALE ILLUMINATION
- ★ SINGLE SWEEP: A triggered sweep of a single waveform can be displayed.
- ★ TV SYNC.: TV composite signals can be easily synchronized.
- ★ MAGNIFIERS: Both vertical and sweep time are simply magnified to 5 times. (1 mV/div., 40 nsec/div.).
- ★ X-Y, or X-Y-Z OPERATION: Simply by turning the "sweep time/div. knob" to CH-B, this functions as a very high sensitivity X-Y oscilloscope (1 mV/div.) with intensity modulation.
- ★ HF REJ: High frequency noises can be rejected for the stable triggering by use of the low pass filter built in the triggering circuit.

REMEMBER: Ex stock, 12 month warranty, High quality components, Direct import, Flat face Internal grille screen, On view at both stores, Our 8th year of business!

CAT. NO.	MODEL	SCREEN	SENS	DEL	TRIG	BW	THASE	WITHOUT TAX	WITH PROBES	EXEMPT PROBES	COMMENTS
012110	645	150mm	1 mV	Y	Y	45 MHz	0.2x0.550x	\$1,045	\$950	\$1,095	(70 MHz-6 dB)
012110	625	150mm	8 mV	N	N	20 MHz	0.5x0.550x	\$548	\$485	\$589	(45 MHz-6 dB)
012110	615	80mm	5 mV	N	N	18 MHz	0.3x0.550x	\$495	\$445	\$500	JAC-DC Operation



## VOYAGER CAR COMPUTER NEW IMPROVED MODEL WITH MASSIVE SAVINGS!!

### ONLY \$125 COMPLETE!!

Originally \$199, the Voyager Car Computer represents absolutely outstanding value for money. The voyager is the only low-cost "full-function" car computer that will give you fuel consumption (the most important feature in a car computer) in both litres/100 km. and good old miles/gallon!  
 The voyager comes absolutely complete with all fitting hardware (even a roll of insulation tape!) Installation generally takes 4-8 hours depending on the vehicle.

### VOYAGER OPERATING FEATURES:

- ★ Instantaneous fuel consumption from sec. to sec. as you drive.
  - ★ Distance travelled since the log computer was last re-set.
  - ★ 5 digit display (10mm high).
  - ★ Fuel used since the log was last re-set.
  - ★ Average fuel consumption since the log computer was last re-set.
  - ★ Instantaneous speed as you drive from sec. to sec.
  - ★ Clock with 12 hour format. Can be used as a stop watch.
  - ★ Straight forward calibration.
  - ★ Metric and Imperial conversions.
  - ★ Light sensor automatically adjusts brightness of display.
  - ★ Average speed over trip.
  - ★ Elapsed time since the trip computer was last re-set. Can be used as a split lap timer.
  - ★ Distance travelled since the trip computer was last re-set.
  - ★ Lights left on alarm.
  - ★ Dimensions 200 (W) X 71 (H) X 90 (D) mm.
- Hundreds sold of the old version at \$199, now you can grab a new improved model, including a full 90 day warranty, for a mere \$125!! That's a colossal saving of \$74!!  
 (As reviewed in EA Oct. '82 and ETI Nov. '82)

Cat. X12010 \$125

**SPARE FLOW SENSORS:** We will be supporting this product for many years to come. To avoid problems changing cars, why not buy a spare fuel flow sensor? They are about the only thing that wears out!

Cat. X12036 \$29.50



Rod Irving Electronics

425 HIGH STREET,  
 NORTHCOTE VICTORIA.  
 Ph:(03)489 8866 489 8131  
 48-50 A'BECKETT STREET,  
 MELBOURNE VICTORIA.  
 PH:(03)347 9251  
 Mail Order and  
 correspondence:  
 P.O. Box 235  
 NORTHCOTE 3070

- ★ NEW LOOK
- ★ NEW PRICES
- ★ NEW PEOPLE
- ★ NEW PRODUCTS
- ★ NEW IDEAS

MAIL ORDER  
 HOT LINE



481 1436

### POSTAGE RATES

\$1-\$9.99	.....	\$1.50
\$10-\$24.99	.....	\$2.00
\$25-\$49.99	.....	\$3.00
\$50-\$99.99	.....	\$3.50
\$100-\$199	.....	\$5.00
\$200-\$499	.....	\$7.50
\$500 plus	.....	\$10.00

Certified Post for orders over \$100 included "free"! Registered Post for orders over \$200 included "free"! Account orders from schools Govt. Depts., Public Cos., gratefully accepted. Min. order of \$20. (or a min. \$5 accounting fee will apply.) Comet Road Freight, Airmail etc. are extra.



## HAVE YOU BEEN INTO OUR CITY STORE???

Conveniently located on the edge of the city where parking is easy! Over 4,000sq. ft. of an extensive range of products and great "in store" bargains... for those interested in computers we have a wide range on display upstairs. For good advice and a good price, see Rod Irving Electronics.



# Top computers -

The new shipment is here!  
Fantastic value - that's the

 **Bondwell**

## Portable Computer: EXCLUSIVE to Dick Smith Electronics

Simply brilliant! That's the all-new Bondwell 14 portable personal computer. Small wonder it has become one of America's top-selling computers in just a few short months - and now the same thing is happening here in Australia.

It's everything you've ever wanted in a computer and much, much more besides: small enough to go anywhere with you, yet large enough to do virtually any computing job.

This incredibly powerful personal portable operates from the world-standard CP/M system: which means there will always be an incredibly large range of software available for it. For virtually any purpose.

That's if you ever ever need any other software: the Bondwell 14 comes with over \$1200 worth of top quality business software (including Wordstar word processing!).

## Look at what else you get:

- Twin double density, double sided disk drives inbuilt (360K capacity each)
- 9in amber screen inbuilt - for minimum glare and fatigue
- Standard parallel and twin RS-232C interfaces inbuilt
- 16 user definable keys for incredibly easy use
- CP/M version 3.0 including a host of utility software - even a SPEECH synthesiser (it can read to you in English!)
- Ergonomically designed keyboard & durable cabinet for complete portability
- PLUS over all this famous Micropro bundled software: Wordstar, Calcstar, Mailmerge, Datastar, Reportstar - worth over \$1200.00!

Cat X-9000

**OVER \$1200 WORTH OF  
SOFTWARE FREE!**

**ALL THIS \$2295  
FOR ONLY**

\*Or from \$233 deposit and \$18.23 per week over 48 months to approved applicants.  
Commercial Leasing also available!



*Dick Smith Electronics Pty Ltd*

**COMPUTERSTOP**



Your one stop computer shop at your



# Computerstop



①

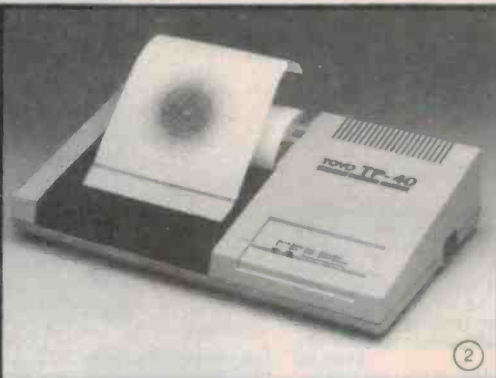

②

## Quality Japanese Hi-Res Monitors ①

Easy on the eyes and the pocket!

Green: X-1222

Amber: X-1227

**\$249**  
EACH

## TP-40 Four Colour Printer Plotter ②

Incredible performance at a bargain price. Centronics type interface.

Cat X-3245

**FREE! 3 ROLLS OF PAPER** Cat X-3246

~~WAS \$169~~ **NOW ONLY \$99**

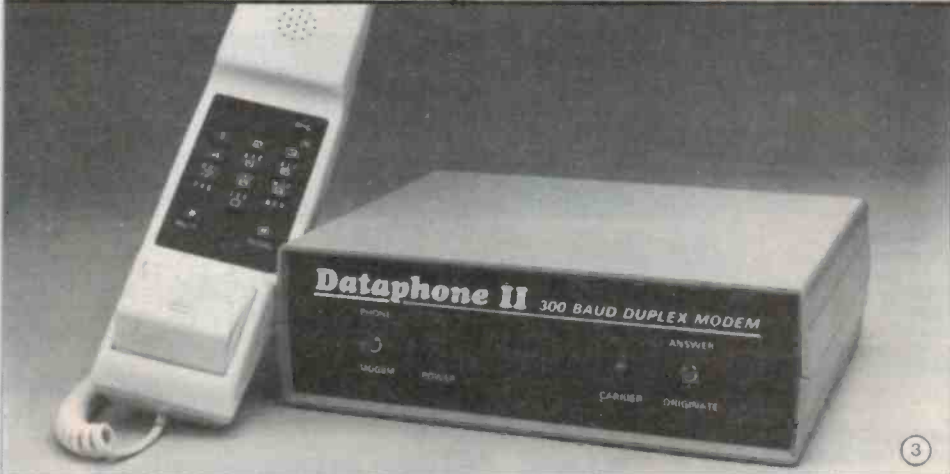

③

## Dataphone II ③

Australia's first and fastest-selling direct data modem, including a pushbutton type electronic phone!

- Authorised by Telecom ● 300 baud full duplex ● Standard RS-232C interface ● Just plug it in - no fees.

Cat. X-3272 **STILL ONLY \$199**

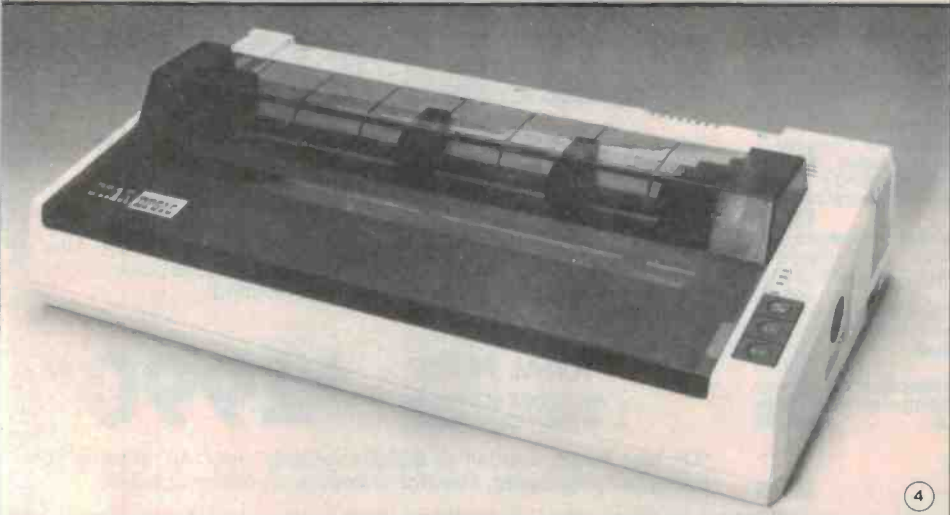

④

## Star DP 515 Dot Matrix Printer ④

Thank your lucky stars! Look at our low, low price! At 100 characters per second and paper width up to 15 inches, it's the ideal printer for your spreadsheet applications.

- Parallel interface
- 100 characters/second
- Huge 9x9 dot matrix
- Bidirectional
- Standard ASCII character set
- Single sheet or sprocket feed

~~WAS \$875~~ **NOW ONLY \$750**

Cat. X-3285

Dick Smith Electronics Pty Ltd

**COMPUTERSTOP**



nearest Dick Smith Electronics Centre.

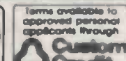
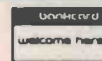

A902A

ETI March 1985 — 81

# DSE's top range of

## Challenger Software

Also suits new 1985 model.

### Utilities

X-8749 TURBO PASCAL - Why pay \$400-\$600 for a Pascal Compiler? For a fraction of the cost you could have Turbo Pascal with features that are outstanding! "If you have the slightest interest in Pascal... buy it." Bruce Webster - Softalk IBM, March 1984. **\$95.00**

X-8750 ELECTRIC PENCIL - An easy to use yet sophisticated word processing program. Function keys definable up to 16 keystrokes of any key combination. Colour available for colour monitor. Underline and bold on screen. Menus give quick and easy reference to all system operations. Manual and Quick Reference Card included. **\$199.00**

X-8751 SIDEKICK - Ever found yourself searching for a calculator, notepad or appointment book when you've got a computer right in front of you? No matter what software you're running, just hit the button and a Sidekick window opens... a calculator, notepad, appointment calendar, auto dialler or ASCII table! **\$95.00**

X-8766 PFS FILE - As per CAT software. **\$175.00**

### Educational

X-8650 MICROSOFT FLIGHT SIMULATOR - The best program of its type in the world. A highly accurate simulation of flight in a single-engine aircraft. Adaptable to any interest or ability level! **\$85.00**

X-8700 ALLIGATOR MIX - Encourages children to practice basic addition and subtraction skills while playing an exciting, fast paced arcade game. Has options for skill level, problem range and run time. For all ages. **\$49.95**

X-8702 DRAGON MIX - As for Alligator Mix, but this time concentrates on multiplication and division skills. **\$49.95**

X-8706 TYPEQUICK - It used to be difficult to learn touch typing, but now computers are making it simple and fun. A complete course of 10 lessons. **\$77.00**

### Adventure & Arcade Games

X-8651 STYX - Fantastic Arcade game action! The swirling STYX has laid seige on the vast expanse of your playing field. Stake your claim and force the STYX into a corner! **\$49.95**

X-8652 DIGGER - Search for buried treasures of shining gold and sparkling emeralds. With chomping jaws, your Digger Mobile must tunnel out mazes and outsmart the Nobbins! **\$49.95**

X-8653 CONQUEST - Transcend the limits of time into a prehistoric era to assume your place as King of the Falcons. Your conquest begins as you swoop down to destroy the mighty pterodactyls. **\$49.95**

X-8654 ZORKI - The definitive adventure game with monstrous scope. The game takes you through a cavernous underground complex - treasures, enchantment and more! Split screen all text display. **\$59.95**

X-8655 DEADLINE - When you take on Deadline, you're pitting yourself against a 12 hour time limit to solve one of the cleverest and most baffling cases in the detective game. **\$75.95**

X-8660 TEMPLE OF APSHAI - A role-playing game that catapults you into a world of magic and monsters - doomed cities and damsels in distress. More than a game, it's an alter-ego experience. Computer Game of the Year! **\$65.95**

X-8662 ULYSSES - The King has assigned you the task of retrieving the legendary Golden Fleece. On your voyages you will encounter the wicked "Sirens", Cyclops, Pluto and the magnificent Pegasus! **\$57.95**

X-8664 APPLE PANIC - (As per CAT software). **\$42.95**

X-8666 FROGGER - The official arcade game. Get across the highway without getting run over, and across the river avoiding deadly snakes, otters, crocodiles and the treacherous diving turtles. **\$48.95**

### Cassette Software

X-8649 STARSHIP CHALLENGER -

**\$49.95**



## New 256K expanded CHALLENGER

Yep, our new two-tone (IBM colours) Challenger, fully assembled with 256K installed is here.

The IBM PC compatible that competes with the IBM... on price, on performance, on features and on expandability. The Challenger is the computer for the small to medium size business. But it's more than that: because it's compatible with the IBM PC software & hardware, it makes a superb scientific or industrial computer... or even an IBM terminal. Cat X-8605

**TOTAL PRICE  
INCLUDES SOFTWARE  
WORTH OVER \$800.**

**\$2990\***

\*Or just \$316 deposit & \$23.54 weekly over 48 months to approved applicants. Monitor shown is an optional extra.

Dick Smith Electronics Pty Ltd

COMPUTERSTOP



Your one stop computer shop at you

# hardware & software!



## CAT Software

### Apple II software compatible CAT!

Australia's best value 64K Computer. That's the CAT. It's the best of both worlds: the very latest and most powerful hardware, plus the ability to run a very broad range of tried-and-proven software. If you want a machine which is software compatible with thousands of popular programs and which is supported by a reputable dealer, our CAT with emulator is good value. Check the CAT out at your nearest Dick Smith Electronics Computerstop. It purrs.

Save \$232 on CAT system!

	Cat. No.	Normally
Basic CAT Computer	X-7500	\$ 699.00
Disk Drive	X-7505/6	\$ 349.00
Disk Controller	X-7510	\$ 149.00
RF Modulator	X-7550	\$ 34.90
		<b>\$1231.90</b>

**SPECIAL OFFER!  
VALUE AT ONLY**

**\$999\***

\*Or \$81 deposit and \$8.31 per week over 48 months to approved applicants.

Basic CAT Computer  
Cat. X-7500

**\$699**

That's near half the price of Apple with similar features!



### Utilities

\*X-7570 Z80 & GPM DISK & MANUAL - Turns your CAT into a Z80 processor - gives you access to the enormous range of CPM software! **\$395.00**

X-7600 VISICALC - The powerful electronic spreadsheet that can calculate and display the answers to involved problems you could have spent hours doing by hand. Easy to learn, easy to use. **\$428.00**

X-7605 SANDY WORD PROCESSOR - A version specially written for the CAT computer, taking advantage of the function keys and 80 column screen. **\$189.00**

X-7610 PFS FILE - An easy-to-use information management package that allows you to record, retrieve, and review information in a fraction of the time it would take with a conventional filing system. **\$175.00**

X-7658 HOW TO PROGRAM IN APPLESOFT™ BASIC - using these 12 self-paced lessons you will learn to program in the popular BASIC computer language. Learn BASIC in two nights or two months! Unique "Let's Talk" feature allows easy review of prior material or skips to new lessons. **\$69.95**

X-7660 BASIC FOR BEGINNERS - An excellent introduction to BASIC for those with no previous programming experience. **\$24.95**

### Educational

X-7652 FLIGHT SIMULATOR - Simulates flight in a single-engine aircraft. Very similar to Challenger Microsoft Flight Simulator. **\$79.95**

X-7661 ALGABRATTACK - Kids learn the fun way by playing this arcade-style game. Makes you wish you were starting again! **\$24.95**

X-7662 ARITHMATTACK - As above but for arithmetic. **\$24.95**

X-7663 FRACTION ACTION - As above but for fractions. **\$24.95**

### Adventure & Arcade Games

X-7700 REACH FOR THE STARS - A fast-paced exciting challenge for up to four players. Three levels of play. Expand and develop your empire, but watch for other empires - they may wipe you out! **\$34.95**

X-7702 ZAXXON (Official version) - The arcade game you must see to believe. Pilot your aircraft through a 3-dimension-like battlefield complete with enemy aircraft, fuel tanks, concealed missiles and tanks. **\$59.95**

X-7704 SUSPENDED - In cryogenic suspension for half a millennium, you are woken up to deal with an emergency. Strategically manipulate six robots, each having a distinct perception of the world to solve a myriad of realistic and original problems! **\$74.95**

X-7716 SARGON III - The Computer Chess champion! Sargon III will play at your level from beginner up through Grand Master. Outstanding display of the chess board. **\$44.95**

X-7722 CARRIERS AT WAR - You command the land-based and/or naval components of either nationality in any one of five historical scenarios. Play against the computer or a friend. **\$44.95**

Dick Smith Electronics Pty Ltd

**COMPUTERSTOP**



nearest Dick Smith Electronics Centre.

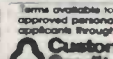
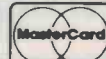

A902B

## IDEAS FOR EXPERIMENTERS

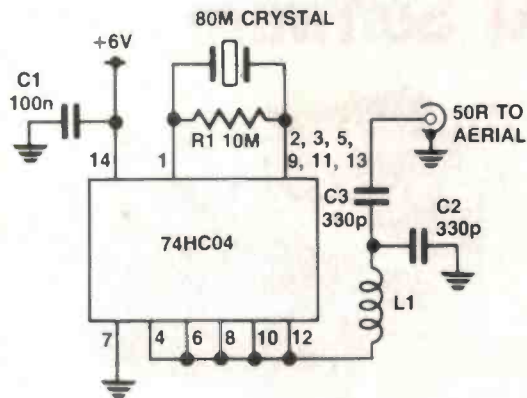

L1 = 10 turns wound on 50 mm of 10 mm ferrite rod. The rod should be loose enough to allow for initial adjustment.

### CMOS 80M transmitter

John Rickard of Heathmont, Vic, has designed this simple circuit for use as a transmitter broadcasting on 80M. It consists of a CMOS inverter wired as a crystal oscillator.

The output is fed to the 50 ohm load by the LC matching circuit which functions to reduce harmonics. The output power is 150 mW or so with a 6 V supply rising to over 200 mW with 7 V in. Over 500 mW has been obtained from the circuit, but this was achieved with a 12 V supply,

and considerably exceeds manufacturers specifications.

The output circuit is brought to resonance by adjusting the position of the ferrite rod in the coil while observing the supply current. A peak in the current coincides with maximum RF output. Keying the transmitter is easily achieved by interrupting the supply.

The circuit could easily be adapted to other frequencies by suitable scaling of the LC output circuit, and substituting a suitable crystal.

## 'IDEA OF THE MONTH' CONTEST

### COUPON

Cut and send to: Scope/ETI 'Idea of the Month' Contest, ETI Magazine, P.O. Box 227, Waterloo NSW 2017.

"I agree to the above terms and grant *Electronics Today International* all rights to publish my idea in ETI Magazine or other publications produced by it. I declare that the attached idea is my own original material, that it has not previously been published and that its publication does not violate any other copyright."

\* Breach of copyright is now a criminal offence.

Title of Idea .....

Signature .....

Name .....

Date .....

Address .....

Postcode .....



'Scope pc board Work Centre

'Scope Laboratories, which manufactures and distributes soldering irons and accessory tools, is sponsoring this contest with a prize given away every month for the best item submitted for publication in the 'Ideas for Experimenters' column — one of the most consistently popular features in ETI Magazine. Each month we will be giving away a pc board Work Centre consisting of the Model 315 adjustable pc board holder with capacity to accept 300 mm boards, Model 300 180° swivel and lock base which can be attached to the Model 312 tray base with wet sponge receptacle, Model 371 solder spool holder and Model STS 3 soldering iron safety stand. Please note prize does not include solder or scope TC60 temperature controlled iron shown above. The prize is worth \$123!

Selections will be made at the sole discretion of the editorial staff of ETI Magazine. Apart from the prize, each winner will be paid \$10 for the item published. You must submit original ideas of circuits which have not previously been published. You may send as many entries as you wish.

**PRIZE WORTH \$123!**

### RULES

This contest is open to all persons normally resident in Australia, with the exception of members of the staff of Scope Laboratories, The Federal Publishing Company Pty Limited, ESN, The Litho Centre and/or associated companies.

Closing date for each issue is the last day of the month. Entries received within seven days of that date will be accepted if postmarked prior to and including the date of

the last day of the month.

The winning entry will be judged by the Editor of ETI Magazine, whose decision will be final. No correspondence can be entered into regarding the decision.

The winner will be advised by telegram the same day the result is declared. The name of the winner, together with the winning idea, will be published in the next possible issue of ETI Magazine.

Contestants must enter their names and addresses where indicated on each entry form. Photostats or clearly

written copies will be accepted but if sending copies you must cut out and include with each entry the month and page number from the bottom of the page of the contest. In other words, you can send in multiple entries but you will need extra copies of the magazine so that you send an original page number with each entry.

This contest is invalid in states where local laws prohibit entries. Entrants must sign the declaration on the coupon that they have read the above rules and agree to abide by their conditions.

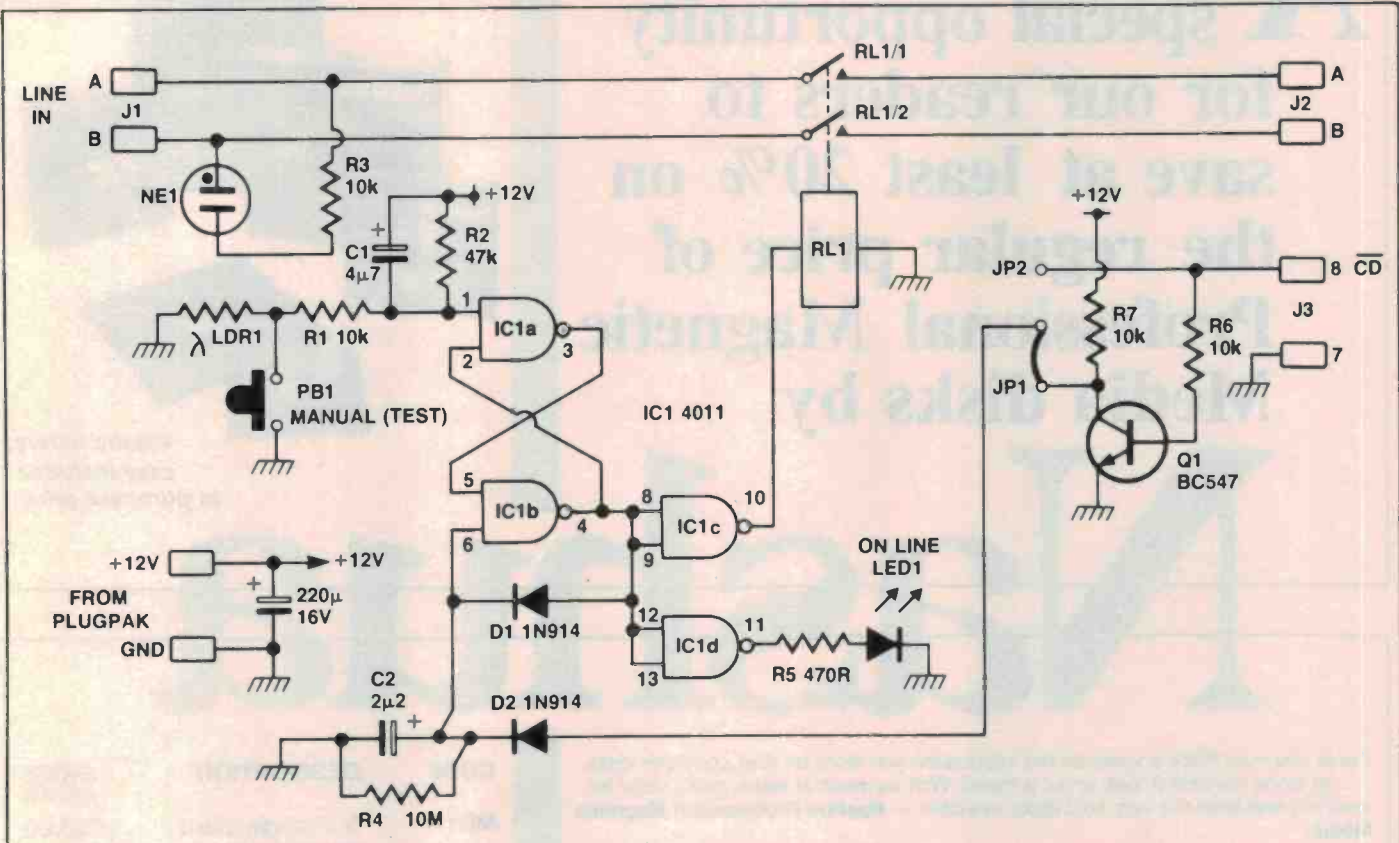

**An auto answer facility**

G. Dicker Coromandel Valley SA

Over the last few years a number of modems have appeared on the open market at very reasonable prices. However, most lack the auto answer facilities of higher priced models. Even if you are prepared to pay the price for an auto answer facility they often require the host system to provide software to control it.

This circuit meets both these objections. It is cheap and it requires no controlling software.

The adaptor detects Telecom ring tone through connector J1. Ring tone consists of a 15 Hz signal at approximately 150 mV

p-p. This turns on NE1, a neon light, which is aimed at a light dependent resistor (LDR). Power to the LDR is provided via an RC network that has a time constant long enough to prevent false triggering due to noise on the line.

When the neon lights, pin 1 of IC1a will be driven low. Since IC1a and 1b are connected as a latch the circuit will switch on with pin 4 latched low. This is inverted by IC1c and used to drive RL1, a miniature relay, which connects the modem to the line.

Q1 is used to detect whether carrier is present by

monitoring the CD output of the modem. Strapping at JP1 or JP2 allows the user to select for either a positive or negative carrier detect (CD) signal. In either event the output from the CD circuit is used to charge the RC network made up of C2 and R4. This circuit has a time constant of about 15 seconds. If carrier is not detected within this time pin 6 of IC1b will go low causing pin 4 to toggle and the modem to drop out.

IC1d is used to drive LED1 which can be used to monitor the status of the circuit. A manual test button is also provided in PB1.

In operation the author used the system to drive an opto isolated mains supply to provide power to the CPU. This meant that the host system could be shut down completely. When an incoming call was received the entire system could be started up.

Construction is fairly straightforward, except that it is important that the neon light and LDR be isolated from ambient light. The author achieved this by using heat shrink to hold the two elements face to face.

**NOTES & ERRATA**

In our December 84 issue we published a circuit for a darkroom timer as the idea of the month. The author, Mr H. Naclnovich, has written to us with regard to a problem that showed up after the unit had been working for a couple of months. The failure was caused by IC2, a 74LS90, not giving the necessary clock output. Reason: not enough drive from the 4018. The solution is to tie pin 1 of IC2 to ground via a 1k resistor.



# New personal computer from Sharp

**FOLLOWING** the release in June last year of its new 16-bit personal computer, Sharp Corporation has announced an upgraded version, the MZ5600, now available on the Australian market.

The new model based on the 8086 chip processing at 8 MHz, is a true 16-bit machine which retains the features of its predecessor, the MZ5500, and incorporates new additional capabilities. The MZ5600 handles complex graphics and data processing, has multi-window facilities allowing text, tables and graphics to be transferred, bit-mapped display, high resolution screen image, optional mouse and hard disk drive.

It also incorporates 640K floppy-disk drives which Sharp says positions the MZ5600 ahead of many competitive models.

MS-DOS is bundled with the system allowing implementation of a wide range of software packages, including the most com-

monly used word processing, spreadsheet and data base packages.

Available accounting software is sourced from IMS, IAL, BCP, Compact, Padmede, Carpe and Davidson. Vertical market packages encompass real estate, video hire management, medical, travel, agricultural and public accountants.

Sharp hopes the wide availability of software will be the key to the success of the MZ5600 and that it is indicative of the company's computer products marketing philosophy that "as long as the hardware is consistently reliable, software holds the key to successful sales".

For further information contact Sharp Corporation. (02)728-9111.

## Arcom Pacific releases new dBase II

**SOFTWARE DISTRIBUTOR** Arcom Pacific has announced the release of dBase II version 2.43 and dBase II Multi-User for the TurboDOS operating system from publisher Ashton-Tate.

dBase II version 2.43 features file indexing from two to six times faster than previous versions and supports the new IBM PC/AT. With the release of the TurboDOS version of dBASE II Multi-user, Ashton-Tate now supports two multi-user environments, the other being 3COM's EtherSeries local area network (LAN).

dBase II Multi-User for the TurboDOS operating system, versions 1.2 and 1.3, is similar to dBase II Multi-User developed for the IBM PC and compatible

computers running on the 3COM EtherSeries LAN. dBase II Multi-User provides all the power of dBase II, while allowing several users to simultaneously access shared data files and application programs. It is completely compatible with single user dBase II, allowing transfer of data files with no modification.

Features include record and index locking, file locking within an application program and password security within an application program.

More than 16 machines run TurboDOS, including North-Star, IMS, and Televideo.

For further information contact Arcom Pacific, 252 Abbotsford Road, Mayne, Qld 4006. (07)52-9522.

## Awards for 'Computer educator of the year'



**NEVILLE WRAN**, Premier of NSW, was the guest of honour and awards presenter at the first annual Dick Smith Electronics 'Computer Educator of The Year' awards.

The award was created to highlight the achievements of someone in the education field who has been judged to be outstanding in his/her work to further the use and role of computers for education in Australia. He or she may work in any capacity or at any level, but must essentially be an innovator or a driving force whose efforts are felt beyond his immediate workplace.

The judges included Mr Colin Woodley, of the Independent Schools Association (NSW), Ms Marilyn Cross, Applied Computer Sciences of Chatswood, NSW, Mr Adrian Farrow, publisher 'Computing In Education' magazine and Mr Ike Bain of Dick Smith Electronics.

From the hundreds of entries received from all parts of Australia, Brother Vin Hawley, of St Edmund's School For the Blind and Visually Handicapped in Wahroonga, NSW was selected to receive the trophy and \$2000 worth of computer

equipment from Dick Smith Electronics.

Brother Hawley has introduced 'Braille'-N-Print' machine to help integrate blind children into regular schools. He has written programs using voice synthesis and large print on six different computers, making it possible for every student at St Edmund's to participate in the 'Computer Awareness' and 'Keyboard Skills' programmes.

Second place went to Mr Murray Luke, Principal of Bemboka Primary School for his work in successful implementation of computers into dozens of schools in the far South East of NSW, assisting and advising them on computer hardware and software purchases.

Mr David Woodrow, Senior Master and Head of the Junior High School at St Peters Lutheran College in Brisbane was the recipient of the third prize. Since 1971 Mr Woodrow has been committed to advancing computers in education not only in Queensland, but on a national basis as well.

The second and third prize winners received a trophy and \$500 worth of computer equipment from Dick Smith Electronics.

## 'Talking stick': Australia's first intelligent modem

A HI-TECH workshop in Hornsby (NSW) has produced the first Australian designed, fully automatic intelligent modem for the switched network, it claims.

Called "Tulpi" — Aboriginal for talking stick — it is a V21 and V23 direct-connect modem with an integrated telephone handset. Designed by Teletext Communication Technology, the modem supports Bell 103 and 202 transmission modes and is Videotex compatible.

Tulpi has no switches or buttons. All commands are passed to it via the RS 232 port, which allows the modem to be controlled from a terminal or by a software package running in a PC.

An in-built 576-byte buffer allows the modem to operate at different baud rates between the line side (Telecom line) and the user side (RS 232 port).

Mr Terrance James, a director of Teletext Communication Technology, said more than \$500 000 had gone into developing the Tulpi modem, of which the Federal Government had contributed a good part.

TCT design engineer Brian Mudditt said the Tulpi's 1200/75 operation was useful when signing into a database like Midas — the gateway to US databases —

or Austpac, the packet switching network.

"The 1200/75 allows all information coming on to the VDU at 1200 bits/sec and data in the other direction at 75 bits/sec (7 char/sec), which is faster than the normal operator can type.

"The split board rate facility used where line speeds differ is a big advantage. The buffer enables a screen sending information at 2400 bits/sec to use the 1200/75 facility, storing and forwarding when it is full. No one offers V22 and lower speeds as well, so if the need is for a gen-

eral purpose modem with auto-dial, Tulpi is ideal because it offers 300 and 1200 half duplex."

ICL has already bought 30 Tulpis and its Traderpoint division is using them to collect account and stock data from its interstate offices.

The Tulpi has non-slip feet for desktop mounting and measures 260 x 250 x 53 mm. It will sell in Australia for about \$1150.

For further information contact Terry James, Teletext Communication Technology. (02)908-1777.



## JED-STD /800 CMOS SINGLE BOARD COMPUTER

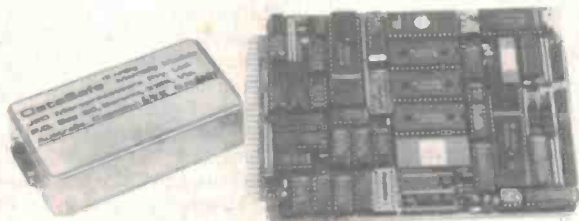

JED Microprocessors announces the availability of the new CMOS CPU board designed and manufactured in Australia. It uses the NSC800 CMOS CPU chip (Z80 code), and HC CMOS logic to bring together the most compact, most powerful and lowest power consumption STD bus computer yet seen anywhere in the world.

On the card is an 8k EPROM with monitor (with single step) and control XT BASIC, the choice of 2k or 8k or RAM, sockets for up to 32k user PROM or 16k more RAM, MM 58167 real-time-clock, 8 channels of 8 or 10 bit analogue in and RS232/20mA serial I/O. It also interfaces to the JED DataSafe 64 Kbyte secure memory box, an ideal way to save data logging data in the field or lab.

The full card is \$400, (down to \$295 with deletions.)

JED has a range of cabinets (\$250), motherboards (\$75), prototyping boards (\$30), extender boards (\$45), and a \$200 PROM programmer all intended to make your data logging or control job easy to implement in either machine code or BASIC.

JED also makes the best and cheapest STD bus 32k memory boards in the world at \$300 with battery backup, or at \$175 with 16 sockets for PROM or RAM.

We also make a \$300 12-bit 8 channel 0-10V/4-20 mA DA card and a replacement for the Prolog 7507 to interface to 24-channel OPTO-22 etc I/O racks at a lower cost and with an optional printer interface, 3-channel counter/timer, RS232 serial I/O and other goodies.

Call for full data sheets on the JED range.

JED Microprocessors Pty Ltd  
28 Anderson St. Boronia, (PO Box 30), 3315  
(03) 762 3588 or (03) 762 3308



## New IBM compatible monochrome monitor

WARBURTON FRANKI has announced the availability in Australia of a new compact monochrome video monitor, the ZVM-124, designed to be used with IBM or IBM compatible personal computers.

The 12-inch amber video display monitor is housed in a cabinet less than 13 inches wide and is designed to be used with the IBM-PC, XT, 3270 PC and those IBM compatible machines using the Monochrome Display Adaptor Card. Other machines using the Hercules Monochrome Graphics Card or the USI Graphics Card (in the mono-

chrome mode) are also able to use the ZVM-124.

The new monitor utilizes the IBM TTL input giving it increased resolution over composite video units designed for use with the IBM Graphics Colour Card.

The ZVM-124, believed to be the only amber monitor available specifically designed for the IBM-PC, will sell in Australia at a suggested retail price of \$359 (incl. tax), including the tilt base option.

For further information contact Warburton Franki, 7 Birnie Ave, Lidcombe, NSW 2141.





## Blind programming by ear

WHEN BLIND computer programmer, Maryanne Diamond at Victoria's Road Traffic Authority (RTA) asked for help in using new computer display terminals, Computer Power came up with a low cost 'talking' solution.

Computer Power supplied a US developed system The Talking Program and the Votrax Type-N-Talk device to provide spoken output as well as the normal visual display.

Maryanne is now able to hear what she is typing and the computer's response. Previously she was limited to the laborious 'reading' of printed computer output line by line using a hand held scanner which provides Braille style output to a touch plate.

Productivity was low due to the method of typing in unchecked computer programs and relying on subsequent checking and verification using the scanner and Braille device.

With the new Talking Program Maryanne could interact directly with the computer's visual display for programming and word processing. She could also take advantage of screen displayed tutorial material for various software products such as spreadsheets. The program reads and speaks individual

characters, a line or a complete screen.

All this gives the visually impaired programmer or computer user much greater flexibility and independence. With the almost universal use of screen based computers and software the visually impaired programmer can bypass painstaking line by line checking of printed output and greatly reduce dependence on assistance from sighted people.

The system set up for Maryanne runs on an IBM PC. With the addition of an Ideacomm emulator card the PC acts as an IBM 3270 terminal for direct connection to the Road Traffic Authority's IBM 4381 mainframe system. This \$4.25 million system is being used to produce Victoria's new plastic Driver Licenses.

As a community contribution, Computer Power says it is prepared to import and pass on 'The Talking Program' to other handicapped users at cost, plus provide free consulting service for its use. The package is available currently in two versions and costs approximately \$800 for the IBM PC version and \$300 for the TRS-80 version.

Further details are available from Computer Power Melbourne. (03)520-5333.

## Australian communication network for world market

A DIGITAL data communications local area network 'Monet', developed at Monash University, Melbourne, will be manufactured in Australia and marketed internationally under a new agreement signed with Racal Electronics Pty Ltd.

The equipment is designed to provide terminal access to multiple computers as well as computer-to-computer access.

Mr Bob Hammond, Racal Electronics Marketing Manager says that if an organisation wanted to connect 200 terminals for instance then the outlay for networking represents a major investment. "The Monet provides customers with a truly affordable local area network for the first time," he said.

The network has been under development at Monash since 1978, and approximately 20 man years of engineering and software have been invested in it.

The fully matured system is in use on the Monash campus where some 700 terminals talk to 17 mainframes. The other current major users of Monet include Telecom Research Laboratories, the Victorian Harness Racing Board, St Vincents and the Victorian TAB.

Mr Hammond said that production of Monet at Racal's North Ryde, Sydney manufacturing plant was well in hand.

Control information for each device is stored in each node in RAM. The RAM has battery backup to avoid losing this control. While these control tables may be accessed from a privileged port, Netman allows "plain English" set up and control. As well, Netman audits and maintains network statistics.

Technically Monet is buss oriented, 1.5 MBS, transformer coupled using CSMA/CD techniques. Terminal speeds to 19.2K bits are allowed. The cable requirement is shielded dual twisted pair. A number of interfaces are available including RS 232 data only (3 wire), RS 232 (V24/V28) data and modem control, RS 422, 20 mA current loop, X21 and X21 bio-synchronous or asynchronous.

Within a few months an X.25 interface will be available and Racal sees this as a very economical solution enabling its electronics funds transfer terminals in retail outlets to be connected to Telecom's packet switched network. As well, a high speed interface between a Monet node and DEC Unibus is to be released shortly. Monet is Telecom Approved.

For further information please contact Mr Bob Hammond, Marketing Manager, Racal Electronics Pty Ltd. (02)888-6444.

## Micro service adds IBM

RMIT's Australian Microcomputer Industry Clearinghouse, AMIC, is to have the support of IBM and shortly, will have a range of IBM's personal computers on permanent display in the Clearinghouse.

IBM's presence, along with many of the other big names in computing, including Apple, Control Data, Digital, Hewlett-Packard, ICL, Insytems (Cromemco and Stearns), and Tandy, will lend greater credibility to AMIC's claim that it represents the major microcomputer products available on the Australian market.

Started in April last year, AMIC provides information and impartial advice to microcom-

puter users and future buyers. It does this by allowing the public to test and evaluate the hardware and software it has on display, or by conducting demonstrations.

As well as the international companies which have joined its ranks, AMIC has a display of Australian produced hardware including Labtam, Hartley, Dulmont Magnum, Case and SME Knight. Six further companies have become software members and there are three peripheral manufacturers.

AMIC is located at Gateway Plaza, 449 Swanston Street, Melbourne. For further information contact Peter Wilkinson, (03)348-1775.

# WHAT DID 6809 WH



"DEAR! YOUR PRECIOUS JO154B WAS ONLY DOING A LITTLE KO187 ON HO271A AND - KERPLUNK!!! I THINK YOUR FAVOURITE E0094! HAS TURNED INTO A JO 172 B YOU'D BETTER SEND IN FOR THE LOT!!!"

## ELECTRONICS: IT'S EASY — VOL 1

**A0001E** \$5.95  
Meters, resistance, capacitance and inductance, emitter followers, op-amps, power supplies, electronic filters.

## ELECTRONICS: IT'S EASY — VOL 2

**A0002E** \$5.95  
Digital sub-systems, counters and shift registers, A-D and D-A conversion, digital instruments and test equipment, computers, transmission links, oscilloscopes.

## BASIC ELECTRICITY/ELECTRONICS — VOL 5

**A0012P** \$15.95  
The principles of motors and generators, three-phase systems and power converters. The final chapter covers servo control systems.

## ELECTRONICS: IT'S EASY — VOL 1

**A0016E** \$12.95  
Meters, resistance, capacitance and inductance, emitter followers, op-amps, power supplies and electronic filters. Hardcover.

## ELECTRONICS: IT'S EASY — VOL 2

**A0017E** \$12.95  
Digital sub-systems, counters and shift registers, A-D and D-A conversion, digital instruments and test equipment, computers, transmission links and oscilloscopes. Hardcover.

## HOW TO READ SCHEMATIC DIAGRAMS

**C0367P** \$10.95  
Covers the various types of electronic diagrams and explains resistors, capacitors, coils, transformers, electron tubes, semi-conductors, switches and relays. An invaluable aid for reading and interpreting the schematic.

## POWER-SUPPLY PROJECTS

**D0047B** \$5.95  
Gives a number of power-supply designs, including simple unregulated types, fixed-voltage regulated type and variable voltage stabilised designs. The designs are all low-voltage types for semiconductor-circuits.

## MODERN FILTER DESIGN

**E0100P** \$65.00  
This book details the advances in active RC filters, both from a practical standpoint and from a state-of-the-art point of view. Gives detailed analysis and design procedures for switched capacitor filters.

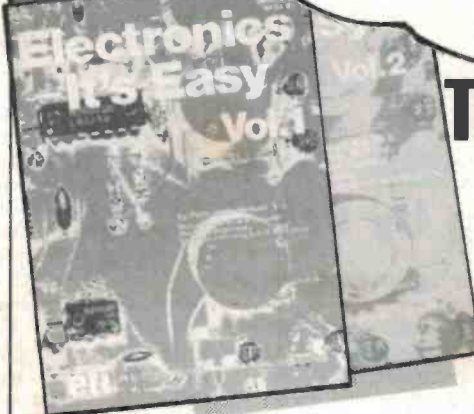

## PRACTICAL SOLID-STATE CIRCUIT DESIGN

**E0094P** \$16.95  
An introductory course in practical solid-state circuit design for the experimenter, designer or technician who is interested in constructing tailor-made circuits.

## MOBILE DISCOTHEQUE HANDBOOK

**G0093B** \$4.95  
Most people who start mobile discos know little about equipment or what to buy. This book assumes no preliminary knowledge and gives enough info to enable you to have a reasonable understanding of disco gear.

## ELECTRONIC SYNTHESISER PROJECTS

**G0133B** \$5.95  
For the electronic music enthusiast, an invaluable reference. This book is full of circuits and information on how to build analogue delay lines, sequencers, VCOs, envelope shapers, etc. The author takes a clear and logical approach to the subject that should enable the average enthusiast to understand and build up what appears to be a quite complex instrument.

## AUDIO PROJECTS

**G0134B** \$6.95  
Covers a wide range of audio projects, including preamplifiers and mixers, power amplifiers, tone controls and matching, etc. Board layouts and wiring diagrams included.

## THIS MONTH'S SPECIAL SELECTION SENT BY RETURN MAIL

### SINGLE-CAMERA VIDEOD PRODUCTION

**G0379P** \$25.75  
Step-by-step diagrams and illustrations show you how to produce low-budget, high-quality video programs. Chapters on audio, lighting, shooting, editing, graphics and set design.

### COBOL FOR BEGINNERS

**H0140P** \$33.95  
It is a solid text for introductory programming courses in Cobol, using a format that is easy to understand, yet comprehensive enough to make supplementary readings unnecessary.

### DON'T (OR, HOW TO CARE FOR YOUR COMPUTER)

**H0153A** \$19.95  
A guide to computer and peripheral preservation. Specific advice for the computer, floppy disks, hard disks, the CRT terminal, the printer, tape units, the computer room, software and documentation.

### YOUR FIRST COMPUTER

**H0271A** \$15.25  
An easy-to-understand beginner's book to small computers. Understanding them, buying them and using them for personal and business applications.

# FILL IN THE REPLY-PAID CARD INSERT

ALL PHONE ENQUIRIES: (02) 663-9999

# SPER IN YOUR EAR?



The book code numbers and their titles will help you make more sense of what she was whispering in his ear!

## SMALLER ORDERS ... FULFILLED JUST AS URGENTLY!

### THE 6809 COMPANION

**J0154B \$6.95**  
This is not a beginner's introduction to micro-processors in general but a discussion of the features of the 6809 and a reference.

### EXPERIMENTS IN ARTIFICIAL INTELLIGENCE FOR SMALL COMPUTERS

**J0168P \$14.25**  
Artificial intelligence is the capability of a device to perform functions normally associated with human intelligence. With this book, a small computer with extended BASIC and some knowledge of BASIC language, you can conduct experiments in artificial intelligence.

### PRACTICAL COMPUTER EXPERIMENTS

**J0172B \$5.95**  
How to build typical computer circuits using discrete logic. Useful intro to devices such as adders and storers as well as a general source book of logic circuits.

### USING THE OSBORNE 1 COMPUTER

**J0327P \$21.50**  
How to get the most out of the Osborne 1 portable computer.

### MICROSOFT BASIC

**J0406A \$24.50**  
Presents a complete introduction and tutorial on programming in BASIC using Microsoft BASIC, Release 5.0. Covers branching and loops, strings, editing, arrays and files, and arithmetic in BASIC.

### BASIC PROGRAMS FOR SCIENTISTS AND ENGINEERS

**K0179A \$25.95**  
Contains scientific and engineering application programs written in BASIC.

*Prices subject to change without notice.*

### PROGRAMMING IN BASIC FOR PERSONAL COMPUTERS

**K0186P \$18.95**  
Simple instructions show how to give BASIC commands and statements a wide range of applications, from programming video games to developing business or scientific programs.

### BASIC FOR EVERYONE

**K0187P \$22.40**  
Some 350 pages of BASIC information for all purposes.

### TRS-80 ASSEMBLY-LANGUAGE MADE SIMPLE

**K0208P \$19.25**  
If you have an understanding of BASIC programming, this will help you to plan, write and hand-assemble your own assembly-language programs in memory, using the T-bug and Level II BASIC ROM subroutines.

### THE ART OF PROGRAMMING THE 1K ZX81

**K0226B \$6.75**  
This book explains how to use the features of the ZX81 including its random number generator, graphics and timer. PEEK and POKE are explained and you should learn enough to develop programs of your own.

### THE C PROGRAMMING LANGUAGE

**K0272P \$26.95**  
C is a general purpose 'low-level' programming language. It is not specialised to any particular area of application, but its absence of restrictions make it convenient and effective for many tasks.

### FORTH PROGRAMMING

**K0298P \$24.25**  
Describes both Forth-79 and fig-Forth and shows how to write software using these languages, add new operations (words) and manipulate the stack. Includes more than 50 useful programs.

### THE C PUZZLE BOOK

**K0375P \$23.00**  
Includes C programs that each explore a particular aspect of C, detailed descriptions of how the programs work and tips on writing successful C programs.

### ELECTRONIC CALCULATOR USER'S HANDBOOK

**M0245B \$5.50**  
Presents formulae, data, methods of calculation, conversion factors, etc, for use with the simplest of most sophisticated calculators. Includes the way to calculate using only a simple four-function calculator, trigonometric function, hyperbolic functions, logarithms, square roots and powers.

### HANDBOOK OF RADIO, TELEVISION, INDUSTRIAL AND TRANSMITTING TUBE AND VALVE EQUIVALENTS

**N0251B \$3.95**  
The equivalents books for amateurs and servicemen. More than 18,000 old and new valves from United States, Britain, Europe, Japan. CV (military) listings with commercial equivalents included.

### RADIO STATIONS GUIDE

**N0252B \$5.95**  
An aid for all those who have a radio receiver. Shows the station site, country, frequency and/or wavelength, as well as Effective Radiation Power of the transmitter and, in some cases, the station's call sign as well.

## AND MAIL IT TO: FEDERAL MARKETING BOOK SALES

140 JOYNTON AVENUE, WATERLOO, NSW 2017

NEW SERVICE FROM  
PLESSEY COMPONENTS

# MEMORY

- Orders over \$100 deduct 5%. • Add \$3.00 for postage.
- Please phone for quantity discounts.
- All prices include Sales Tax.

S RAM		PRICE EACH	QUANTITY
<b>6264P</b>	150ns	\$25.50	_____
<b>6116P4</b>	200ns	\$ 5.50	_____
<b>6116LP4</b>	200ns	\$ 5.50	_____
DRAM			
<b>4164</b>	150ns	\$ 5.50	_____
<b>50256</b>	150ns	\$26.50	_____
EPROM			
<b>2716</b>	450ns	\$ 7.00	_____
<b>2532</b>	450ns	\$ 7.00	_____
<b>2732</b>	450ns	\$ 6.50	_____
<b>2764</b>	250ns	\$ 8.50	_____
<b>27128</b>	300ns	\$18.00	_____

**PLESSEY**  
Components



Mail to  
PLESSEY COMPONENTS PTY. LTD.  
P.O. BOX 2 VILLAWOOD NSW 2163

Enclosed is cheque/postal order valued at \$ .....

Name: \_\_\_\_\_

Address: \_\_\_\_\_

Phone: \_\_\_\_\_

# NiCads

- Widest selection • Rapid charging • Up to 2000 discharge cycles • Indefinite shelf life
- No maintenance • Prime specs • Data supplied
- Prices include sales tax

TYPE	CAPACITY Ah	DIA mm	H mm	PRICE EACH	QTY
1/2AAA	0.07	10	22.5	\$ 2.00	_____
1/3AA	0.10	14.5	17	\$ 2.25	_____
AAA	0.18	10.5	44.5	\$ 2.40	_____
N	0.15	12	30	\$ 2.40	_____
1/2AA	0.25	14.5	30.5	\$ 2.40	_____
2/3AF	0.45	17.3	28.1	\$ 3.50	_____
AA	0.50	14.5	50.2	\$ 3.15	_____
AF	0.80	17.3	49.2	\$ 3.80	_____
3/5C	1.00	26.0	30.5	\$ 6.40	_____
RR	1.20	22.7	42.1	\$ 4.35	_____
C	2.0	25.9	49.7	\$ 8.50	_____
1/2D	2.2	33.0	38.0	\$ 9.00	_____
D	4.0	32.9	60.5	\$ 8.50	_____
F	7.0	32.9	91.3	\$14.60	_____

P&P Orders up to \$50 - \$3.00, \$50 to \$200 - \$5.00, \$200+ - \$7.50

**PLESSEY**  
Components



Mail to  
PLESSEY COMPONENTS PTY. LTD.  
P.O. BOX 2 VILLAWOOD NSW 2163

Enclosed is cheque/postal order valued at \$ .....

Name: \_\_\_\_\_

Address: \_\_\_\_\_

Phone: \_\_\_\_\_

Everything  
from blatant  
pose machines to  
businesslike  
bush-bashers

overlander's  
**CUSTOM 4WD**

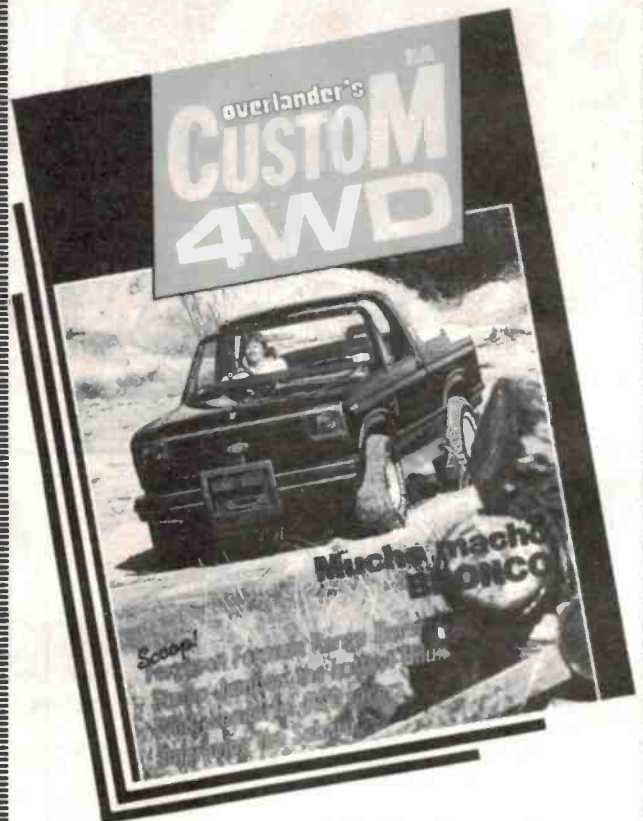

Range Rover, Land Rover, Land Cruiser, Patrol, Hilux, Bronco, Tercel, Subaru — every one improved or modified. Some were specially built as motor show exhibits and other are the result of their owner's imagination.

Plus a special feature on what lurks behind the bodywork of the most successful 4WD racers. If you thought it was impossible for a 4WD to look great or perform like a muscle car, then CUSTOM 4WD will prove you wrong . . .

**On sale now for \$2.95**

# NEW DOT-MATRIX PRINTER

## offers 100 CPS at low cost

In case you haven't noticed, dot matrix printers have become even more attractive than before. They're now offering faster throughput, better print quality and a wider range of typestyles — all at lower cost. Here's a review of the new CPA-80 printer from Creative Technology International.

Jim Rowe

ALTHOUGH PRINTER technology hasn't developed in quite the same leaps and bounds as computers themselves, many advances have been quietly making themselves apparent. It's only four or five years ago that an 80 cps dot-matrix printer would have cost you around \$1000, and those of us who watched the dramatic fall in the price of computers were lamenting the lack of a similar drop in printer prices.

It took a while for printer manufacturers to catch up, but in the last couple of years they've been making up for lost time. The big step forward seemed to come when they realised that instead of using complicated mechanisms and simple electronics, it would be far better to use simple mechanisms with much more 'intelligent' electronics.

A printer then became nothing more than another dedicated microcomputer, operating a few small stepper motors and hammer solenoids and sensing a few microswitches and opto detectors under the control of a program in a ROM chip.

The Japanese manufacturers seemed to grasp this concept first, and they've been leading the field ever since. I suspect this is not just because they made the design breakthrough, but because at the same time they also changed their marketing and selling strategy. Instead of treating printers in the up-until-then traditional way as a prestige, name-branded product line, they started treating them as a commodity: products to be cranked out by the tens of thousands, and sold through all available channels — with whatever labels and cosmetics those channels required.

The floodgates opened a couple of years

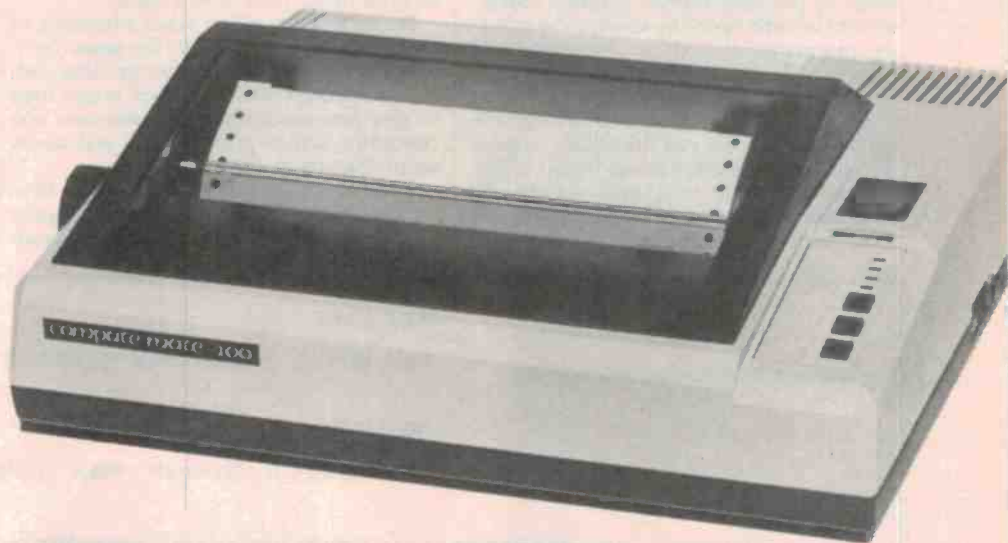

ago, with the release of a 'family' of 80 cps dot-matrix printers, which have been selling quite well up until now. They're virtually all based on the same mechanism and electronics, with slightly different cases and control buttons. In Australia they go under names like BX-80, BT-80, Fax-80, DP-80 and Super-80 (to name but a few).

Whether or not they all come out of the same factory in Japan, Korea or Taiwan I don't know; although I suspect so. Not that it matters, of course. Generally speaking, they're all excellent little printers — and so much better than previous models in terms

of performance/price that where they come from isn't really important. They're compact, reliable and quick, their print quality is good and they cost around \$500; roughly half the price of comparable earlier models. What more could you want?

Yes I know, that's a silly question. We want even more features with even lower prices, right?

What's more, we've now got them. The next generation of dot-matrix printers has just arrived, and although they've had surprisingly little fanfare, don't be fooled. They're quite a significant step forward. ▶



## ADVANCED TECHNOLOGY PRINTERS



### THE ENHANCED CPA-80 100cps DOT MATRIX PRINTER

Centronics I/Face	Tax Free	\$272.05
	Tax Included	\$299.00
RS232C I/Face	Tax Free	\$289.46
	Tax Included	\$329.00



### UCHIDA DWX-305 18cps DAISY WHEEL PRINTER

- Centronics I/Face standard
- Fully proportional, 10, 12 and 15 pitch
- Variety wheels available \*\*
- Tractor and Cut Sheet Feed available \*\*
- Serial I/Face available \*\*

** enquire for cost	Tax Free	\$499.00
	Tax Included	\$598.30

### SHINKO 131 0 300cps DOT MATRIX PRINTER

- Near letter quality print at 60cps
- RS232C and Centronics I/Face
- Heavy Duty Mechanism

	Tax Free	\$1218.75
	Tax Included	\$1377.77

### SHINKO 1600 180cps DOT MATRIX PRINTER

- 16 pin head for quality printing

	Tax Free	\$1375.00
	Tax Included	\$1550.58

ORDERS FREIGHT FREE  
TO CAPITALS & MOST  
MAJOR CENTRES

FOR SPEEDY DISPATCH  
OF YOUR ORDER  
PHONE (008) 777-147

AND QUOTE YOUR BANKCARD  
NUMBER

**energy  
CONTROL**



**Rockwell**

73 Eric St., Goodna, 4300 Qld, Australia  
P.O. BOX 6502, GOODNA, QLD, AUSTRALIA 4300  
TELEPHONE: (07) 288-2455/TELEX: AA 43778 ENECON

## SWANN ELECTRONICS INTERNATIONAL PTY. LTD. PROUDLY INTRODUCE OUR NEW 79 SERIES PUSH BUTTON SWITCH



PROUDLY  
AUSTRALIAN  
MADE

### Features Include

- Compact styling
- SECV approved 10 amp 240 volt
- 4.8 mm QC terminals
- DPST latched or momentary switching
- Illuminated versions available in 240V, 110V, 24V, or 12V
- Printed legends suitable for many applications

Available from:



**SWANN ELECTRONICS  
INTERNATIONAL**  
PTY. LTD.

Melbourne (03) 544 3033  
Sydney (02) 807 1944  
N.Z. (9) 444 3620

IAN J. TRUSCOTTS

## Electronic World

Kits, tools, components  
books etc.

Products from  
Dick Smith  
&  
Altronics

Everything for the  
electronic hobbyist

Now open till 9pm  
Friday evenings.

## Electronic World

Cnr. Lacey St. and  
Windsor Rd.  
Croydon, 3136, Vic.  
Phone: (03) 723 3094

# Stick it!

## SAVE HEAPS — BUY YOUR MEMORIES BY THE STICK!

## PREMIUM GRADE PRODUCT AND HEAPS OF STOCK!!!

## 64K D-RAM

PART No.	PRICE	QTY. PER STICK
HM 4864-150	\$ 79.00*	25
UPD 8748D	\$163.00*	10
UPD 8749D	\$200.00*	10
M5L 2764K	\$139.00*	14
HM 6264 LP-15	\$210.00*	10

# Promark Electronics

**SYDNEY 439-6477**

P.O. BOX 381, CROWS NEST, NSW 2065.

**MELBOURNE 878-1255**

P.O. BOX 115, NUNAWADING, VIC. 3131.

ANYWHERE ELSE IN  
AUSTRALIA CALL  
TOLL-FREE (008) 226-226

\* Plus 20% Sales Tax + \$4.00 Freight.

BANKCARD O.K.

# MORE CHATTERBOX APPLICATIONS

Offering economical and elegant solutions to the problems of speech synthesis is one thing, and with handy programs for Microbees and Apples another, but what about the Commodore or BBC hacker? Well, further to the Chatterbox . . .

**Tom Moffat**

39 Pillinger Drive, Fern Tree, Tas 7101.

THE ETI-677 Chatterbox project has proved popular since it was presented in January, with many requests for information and applications software received since the project was mentioned, long before it was actually published.

January's ETI described the project itself, and included some software for the Microbee and Apple computers. This month we present some more software applications, for the popular Commodore and BBC micros.

## The 'Beeb'

Connecting the Chatterbox to the BBC is easy, you just plug it in where the printer goes and configure the synthesiser for the Centronics option. You must supply the operating power externally; a 9 volt plug pack works nicely.

To send data to the Chatterbox you enable the Beeb's printer option using "VDU 2" and then print an ASCII string. You must disable the screen while doing this to prevent the ASCII rubbish from filling it up!

You'll notice that the Beeb version of "Sayings of the Daleks" is almost identical to the original Microbee program. Even most of the line numbers are the same. Both computers allow the generation of all the ASCII characters so the phonemes can be stored as ASCII strings instead of individual numbers in the DATA statements. Both computers also allow you to RESTORE to a line number, making it very easy to access the appropriate line of data. You can exit the BBC version of the program with "control-C".

We'll leave it to you to convert the Microbee's phoneme editor program to work on the Beeb. I ran out of steam.

## The Commodore

The easiest way to get speech data out of

### LISTING 1: BBC "SAYINGS OF THE DALEKS"

```

100 REM *** SAYINGS OF THE DALEKS *** for the B.B.C. Computer
110 REM
120 REM --- Tom Moffat, December 14, 1984
130 REM
140 MODE 3: REM Set screen for 80x25 text
150 X=RND(16): REM Random number between 1 and 16
160 X=(X-1)*10+1000: REM Index into data statements at line 1000
170 RESTORE X: READ A1$: VDU 6: VDU 3: PRINT A1$
180 READ A1$: VDU 2: VDU 21: PRINT CHR$(126);A1$;CHR$(126):
190 IF INKEY$(400)<>CHR$(3) THEN 150: REM Delay and check for ^C
200 VDU 6: VDU 3: END
210 REM
220 REM TEXT AND VOTRAX DATA INDEXED TO LINE 1000
230 REM
1000 DATA The hostiles must be exterminated.
1005 DATA ys[]_jUaX_Lr_jN!BY_jzLJMAajr^
1010 DATA The Daleks must be obeyed.
1015 DATA ys^dXBY_Lr_jN!fN(a^
1020 DATA You must obey.
1025 DATA ihLr_jcfn(a
1030 DATA Take the patient to the examination centre.
1035 DATA jBaYyre'GrMjCjhy:B\Ro@LKMBaGqM_BEMjz
1040 DATA You must cooperate. You must lie down.
1045 DATA ivwLr_jYtmUeckAaj^bvwlr_jxUb^UwM
1050 DATA You will remain silent.
1055 DATA bvwmgXk:L'aM_UaXAMj
1060 DATA The Daleks are the superior being.
1065 DATA yrC^dXBY_Ukyr_vegkbzNlKT
1070 DATA We do not need assistance.
1075 DATA m!^vwmUjM!^H_K_jHM_
1080 DATA You will assassinate the members of the high council.
1085 DATA ivwmKXH_n_JM'jyrLBNzRrOyr[U@iYUcM_BX
1090 DATA We have been sent by the Supreme Dalek.
1095 DATA m!foON:M_BMjNUbxr_ivwekL^UXBY
1100 DATA We obey Davros. He is our leader.
1105 DATA m!fNBiC^oHOkU_~^lgl_UzXl^z
1110 DATA The prisoner is secured.
1115 DATA yrekK_rM@zgRC_@Yivz^
1120 DATA EMERGENCY! EMERGENCY! The enemy must be destroyed!
1125 DATA :Lz^ZrM_1^:Lz^ZrM_1^y1(MqLlLr_jN1^@_jKf1^
1130 DATA Nothing will interfere with the destiny of the Daleks.
1135 DATA MqyJtMlX@Mjz]gzmJxyr^A_j@M!rOyr^UXBY_
1140 DATA The collapse of Earth society will soon occur.
1145 DATA ysYUXne_rOzky_u_UaBj:mJX_vhMuYzk
1150 DATA You have not won Doctor. Join me and I will make you the
ruler of the world.
1155 DATA ivw[foOMUjmsM^SYjz^ZuKMLlCnM^UIimJXLEaYcIvwyskhXzsOyrmzX^

```



the Commodore and into the Chatterbox is via the user port. Flexible Systems has designed an interface card for this very purpose. It connects the Chatterbox into one of those scarce Commodore plugs and provides a power supply for the Chatterbox from the 9 volts ac provided by the Commodore.

The user port is best attacked with PEEKS and POKES. It is first set up as an output with "POKE 56579,255". You send a byte to the Chatterbox by POKEing it to 56577. You then keep inspecting 56589 until it is not zero (sub 790). This reads the Chatterbox busy signal and prevents a new phoneme being sent until the current one is finished.

Since we are POKEing things, the data must be stored in the DATA statements as numbers instead of ASCII strings. This takes up a bit more room, but as the old saying goes, that's the way the cookie crumbles!

Craig Ford-King has also written a version of the phoneme editor for the Commodore 64. When first run it does the same thing as the Microbee and says "testing". You then type in your new phonemes with one space between them and then hit "Return". The phonemes are displayed as the phrase is compiled. Use the standard Commodore edit procedures to edit the line; then press "Return" to hear it again. You can print the result to a printer with "PR



(Return)". An illegal phoneme will be signalled in the appropriate way.

That makes four computers we've pre-

sented Chatterbox applications for. May the whole lot of them drive you bonkers with their never-ending babble!!

## LISTING 2: COMMODORE CHATTERBOX SPEECH EDITOR

```

100 REM
110 REM - CHATTERBOX SPEECH EDITOR -
114 REM
115 REM - FOR THE COMMODORE 64 -
120 REM
130 REM - BY CRAIG FORD-KING -
140 REM
150 REM - 6-12-'84 -
160 REM
170 REM
180 REM OPEN I/O PORT
190 REM
200 POKE 56579,255
210 S=56577:R=56589
220 DIM A1$(255),B1(255)
270 PRINT CHR$(5);" "
280 REM
290 REM SAY 'TESTING' WHEN INITIALIZED
300 REM
310 A$="T E M S T I N G":GOTO 350
320 B$=A$:INPUT A$
330 IF A$=B$ THEN 770
340 IF A$="PR" THEN A$=B$:GOTO 820
350 WC=0:LC=1
360 FOR I=1 TO 255:A1$(I)="":NEXT I
370 IF MID$(A$,LEN(A$),1)=" " THEN 390
380 A$=A$+" "
390 LA=LEN(A$)
400 REM
410 REM FIND NUMBER OF PHONEMES
420 REM
430 FOR I=1 TO LA
440 IF MID$(A$,I,1)=" " THEN WC=WC+1
450 NEXT I
460 REM
470 REM SEPERATE THE PHONEMES FROM THE
475 REM STRING
480 REM
490 FOR I=1 TO WC
500 A1$(I)=A1$(I)+MID$(A$,LC,1)
510 LC=LC+1
520 IF MID$(A$,LC,1)<> " " THEN 500
530 LC=LC+1
540 NEXT I
550 PRINT "J"
560 REM
570 REM SEARCH FOR PHONEME IN DATA
580 REM AND GIVE IT A VALUE
590 REM
600 PRINT"SEARCHING FOR : ";
610 FOR I=1 TO WC
620 PRINT A1$(I);" ";
630 E=0
640 FOR J=1 TO 63
650 READ B$,P
660 IF B$=A1$(I) THEN B1(I)=P:E=1:J=63
670 NEXT J
680 IF E=1 THEN 690
685 PRINT:PRINT:PRINT"ILLEGAL PHONEME"
686 GOSUB 920:PRINT:E=0:I=WC:X=1:PRINT
690 RESTORE
700 NEXT I
710 IF X=1 THEN X=0:GOTO 880
720 PRINT
730 REM
740 REM ADD PAUSES TO FRONT AND END
750 REM THEN SAY IT!
760 REM
770 B1(0)=126:B1(WC+1)=126
780 FOR I=0 TO WC+1
790 POKE S,B1(I):GOSUB 960
800 NEXT I
810 POKE S,63:GOTO 870
820 REM
830 REM PRINT OUT PHONEME CODES
840 REM
843 FOR TT=1 TO 40:PRINT"-":NEXT TT
845 OPEN 1,4
850 PRINT#1:PRINT#1,"PHONEMES: ";A$:PRINT#1
855 PRINT:PRINT "PHONEMES: ";A$:PRINT

```

## LISTING 2 cont.

```

860 FOR I=0 TO WC+1:PRINT#1,B1(I);NEXT I:PRINT#1
863 FOR I=0 TO WC+1:PRINT B1(I);NEXT I:PRINT
865 CLOSE 1,4
867 FOR TT=1 TO 40:PRINT"";NEXT TT
870 PRINT:PRINT " ";A$:PRINT
880 GOTO 320
890 REM
900 REM SAY ERROR MESSAGE
910 REM
920 FOR D=1 TO 23
930 READ P:POKE S,P:GOSUB 960
940 NEXT D:RETURN
954 REM
955 REM READ INTERRUPT
956 REM
960 IF PEEK(R)=0 THEN 960
970 RETURN
980 REM
990 REM CODES FOR PHONEMES

1000 REM
1010 DATA "A",96,"A1",70,"A2",69,"AE",110,"AE1",111
1020 DATA "AH",100,"AH1",85,"AH2",72,"AW",125,"AW1",83
1030 DATA "AW2",112,"AY",97,"B",78,"CH",80,"D",94
1040 DATA "DT",68,"E",108,"E1",124,"EH",123,"EH1",66
1050 DATA "EH2",65,"EH3",64,"ER",122,"F",93,"G",92
1060 DATA "H",91,"I",103,"I1",75,"I2",74,"I3",73
1070 DATA "IU",118,"J",90,"K",89,"L",88,"M",76
1080 DATA "N",77,"NG",84,"O",102,"O1",117,"O2",116
1090 DATA "OO",87,"OO1",86,"P",101,"PA0",67,"PA1",126
1100 DATA "R",107,"S",95,"SH",81,"T",106,"TH",121
1110 DATA "THV",120,"U",104,"U1",119,"UH",115,"UH1",114
1120 DATA "UH2",113,"UH3",99,"V",79,"W",109,"V",105
1130 DATA "V1",98,"Z",82,"ZH",71
1145 DATA 126,121,111,106,67,75,82,67,111,77,74,88,124
1150 DATA 92,72,88,93,116,109,77,66,76,126

READY.

```

## LISTING 3: COMMODORE "SAYINGS OF THE DALEKS"

```

100 REM SAYINGS OF THE DALEKS
105 REM
107 REM FOR THE COMMODORE 64
110 REM
112 REM BY CRAIG FORD-KING
130 REM
140 REM 6-12-'84
150 REM
160 REM
170 REM - OPEN I/O PORT -
180 REM
190 POKE 56579,255
200 S=56577:R=56589
210 PRINT"OK"
220 FOR I=1 TO 10:PRINT:NEXT I
230 PRINT TAB(13)"LOADING ARRAY"
240 DIM A1(30),A2(20),A3(13),A4(46),A5(36)
245 DIM A6(20),A7(47),A8(39),A9(33),A0(28)
250 REM
260 REM - READ DATA INTO ARRAYS -
270 REM
280 READ NI:A1(0)=NI:FOR C=1 TO NI
290 READ NO:A1(C)=NO:NEXT C
300 READ NI:A2(0)=NI:FOR C=1 TO NI
310 READ NO:A2(C)=NO:NEXT C
320 READ NI:A3(0)=NI:FOR C=1 TO NI
330 READ NO:A3(C)=NO:NEXT C
340 READ NI:A4(0)=NI:FOR C=1 TO NI
350 READ NO:A4(C)=NO:NEXT C
360 READ NI:A5(0)=NI:FOR C=1 TO NI
370 READ NO:A5(C)=NO:NEXT C
380 READ NI:A6(0)=NI:FOR C=1 TO NI
390 READ NO:A6(C)=NO:NEXT C
400 READ NI:A7(0)=NI:FOR C=1 TO NI
410 READ NO:A7(C)=NO:NEXT C
420 READ NI:A8(0)=NI:FOR C=1 TO NI
430 READ NO:A8(C)=NO:NEXT C
440 READ NI:A9(0)=NI:FOR C=1 TO NI
450 READ NO:A9(C)=NO:NEXT C
460 READ NI:A0(0)=NI:FOR C=1 TO NI
470 READ NO:A0(C)=NO:NEXT C
480 PRINT"J"
490 REM
500 REM - PICK A NUMBER 1 TO 10 -
510 REM
520 X=INT(PND(1)*10)+1
530 ON X GOSUB 580,600,620,640,660,680,700,720,740,760
540 REM
550 REM - PAUSE BETWEEN SAYINGS -
560 REM
570 FOR T=1 TO 500:NEXT T:GOTO 520
580 GOSUB 780:PRINT" THE HOSTILES MUST BE EXTERMINATED!"
590 FOR C=1 TO A1(0):POKE S,A1(C):GOSUB 790:NEXT C:RETURN
600 GOSUB 780:PRINT" THE DALEKS MUST BE OBEYED!"
610 FOR C=1 TO A2(0):POKE S,A2(C):GOSUB 790:NEXT C:RETURN
620 GOSUB 780:PRINT TAB(13)"YOU MUST OBEY!"
630 FOR C=1 TO A3(0):POKE S,A3(C):GOSUB 790:NEXT C:RETURN

640 GOSUB 780:PRINT" TAKE THE PATIENT TO THE EXAMINATION"
645 PRINT TAB(13)"CENTRE. PROCEED"
650 FOR C=1 TO A4(0):POKE S,A4(C):GOSUB 790:NEXT C:RETURN
660 GOSUB 780:PRINT" YOU MUST CO-OPERATE, YOU MUST LIE DOWN!"
670 FOR C=1 TO A5(0):POKE S,A5(C):GOSUB 790:NEXT C:RETURN
680 GOSUB 780:PRINT TAB(9)"YOU WILL REMAIN SILENT"
690 FOR C=1 TO A6(0):POKE S,A6(C):GOSUB 790:NEXT C:RETURN
700 GOSUB 780:PRINT" THE DALEKS ARE THE SUPERIOR BEING."
705 PRINT TAB(7)"WE DO NOT NEED ASSISTANCE"
710 FOR C=1 TO A7(0):POKE S,A7(C):GOSUB 790:NEXT C:RETURN
720 GOSUB 780:PRINT" YOU WILL ASSASSINATE THE MEMBERS OF THE"
725 PRINT TAB(14)"HIGH COUNCIL"
730 FOR C=1 TO A8(0):POKE S,A8(C):GOSUB 790:NEXT C:RETURN
740 GOSUB 780:PRINT" WE HAVE BEEN SENT BY THE SUPREME DALEK"
750 FOR C=1 TO A9(0):POKE S,A9(C):GOSUB 790:NEXT C:RETURN
760 GOSUB 780:PRINT" WE OBEY DAVROS. HE IS OUR LEADER"
770 FOR C=1 TO A0(0):POKE S,A0(C):GOSUB 790:NEXT C:RETURN
780 PRINT"J":FOR T=1 TO 10:PRINT:NEXT T:RETURN
790 IF PEEK(R)=0 THEN 790
800 RETURN
810 REM
820 REM AND NOW THE VOTRAX DATA...
830 REM
840 DATA 29,121,115,91,125,95,106,85,97,88
843 DATA 95,76,114,95,106,78,124,66,89,95,106
845 DATA 122,76,74,77,65,97,106,114,94
850 DATA 19,121,115,94,100,88,66,89,95,76,114
855 DATA 95,106,78,124,102,78,123,97,94
860 DATA 12,105,104,76,114,95,106,67,102,78,123,97,67
870 DATA 45,106,66,97,89,121,114,101,96,81,114
873 DATA 77,106,67,106,104,121,124,65
875 DATA 92,82,111,64,76,75,77,66,97,81,113
876 DATA 77,95,66,64,77,106,122,126,126,101
877 DATA 107,117,95,124,105,94
880 DATA 34,98,118,119,76,114,95,106,89,116
883 DATA 109,85,101,99,107,65,97,106,125,126
885 DATA 98,118,119,76,114,95,106,88,85,98,94,85,119,77,67
890 DATA 19,98,118,119,109,103,88,107,124,76
895 DATA 96,97,77,95,85,97,88,65,77,106
900 DATA 46,121,72,67,94,100,88,66,89,95,100
903 DATA 107,121,72,95,118,101,103,107,98
905 DATA 122,78,108,75,84,126,126,109,124,94
906 DATA 118,118,77,100,106,77,124,94,72,95
907 DATA 103,95,106,72,77,95,67
910 DATA 38,105,118,118,109,103,88,72,95,110
913 DATA 95,74,77,96,106,121,66,76,66,76,78
915 DATA 122,95,100,79,121,85,91,85,64,105,89
917 DATA 85,99,77,95,66,88,67
920 DATA 32,109,108,91,111,79,98,124,77,95,66
923 DATA 77,106,78,72,64,105,121,64,95,105
925 DATA 118,119,101,107,108,76,94,85,88,66,89,67
930 DATA 27,109,108,102,78,66,105,67,94,111,79
933 DATA 107,85,95,126,126,91,108,103,95
935 DATA 85,99,122,88,108,94,122,67

READY.

```

BANKCARD HOLDERS—PHONE ALTRONICS TOLL FREE 008 • 999 • 007 FOR NEXT DAY JETSERVICE DELIVERY

**ALTRONICS**  
COMPONENTS

# NEW PRODUCTS

**DELIVERED RIGHT TO YOUR DOOR NEXT DAY\***

\*Altronics Famous Jetservice Delivery to all Capital Cities and suburbs—Country Areas please allow additional 24-48 Hours



## NEW Micron Series 3



**FREE FREIGHT**  
Exclusive to Altronics—yes we will deliver your Monitor free right to your door.

## High Definition Computer Monitor

There are a number of low cost 'Hobbyist' monitors around these days at prices unheard of a year or so ago. However, they all suffer from poor to medium definition or resolution—hence eye strain becomes a real headache. The situation has all changed with the 1985 release of the superb Micron Series 3. Non glare, naturally, and screen character resolution well worthy of mating up with top end personal or professional computers.

- 1050 lines resolution at centre screen • 22MHz bandwidth • Video Input Impedance switch allows networking use • Incredible—repeat—Incredible—Resolution.

**SPECIFICATION:**

Screen—Green phosphor Front Controls—Power on/off, character brightness/intensity, display centering Rear controls—Background intensity, vertical and horizontal adjustment etc. Input Impedance—Switch 75/10K  
Bandwidth—10Hz-22MHz Resolution—1050 lines minimum at centre screen.

### AMBER AND GREEN SCREEN MODELS

D 1115	Green Non Glare	<b>\$179</b>
D 1116	Amber Non Glare	<b>\$189</b>

## STATE OF THE ART

### PRESSURE SENSITIVE—ETCH RESISTANT

#### PC ART AIDS BY IZUMIYA

Altronics proudly announce the inclusion to our range of the **FANTASTIC IZUMIYA PCB ARTWORK AIDS**—The incredible feature of IZUMIYA tapes, symbols etc. Is, unlike most others, they are etch resistant—that is you can lay artwork direct on to the copper face of the PCB and etch directly with ferric chloride! — Naturally you can use them to prepare finished artwork to paper, film, metal in the normal manner.

#### ART TAPE CUTTING KNIFE



- SPARE T 2390 \$4.95  
PACK OF 6 BLADES T 2392 \$1.25

#### SINGLE SHEET PACKS

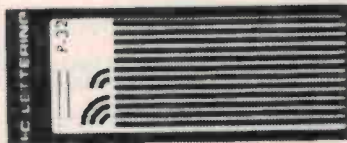

ALL \$1.95ea or 10 Up  
SAVE OR MIX \$1.60

#### DOUGHNUTS

- |     |     |        |
|-----|-----|--------|
| 2mm | ●   | H 8601 |
| 3mm | ●●  | H 8604 |
| 4mm | ●●● | H 8605 |

#### OVAL PADS

- |           |   |        |
|-----------|---|--------|
| 3 x 2mm   | ● | H 8610 |
| 4.5 x 3mm | ● | H 8611 |

#### DIL IC PADS

- |        |     |        |
|--------|-----|--------|
| Single | ●   | H 8641 |
| Triple | ●●● | H 8642 |

#### TRACKS

- |       |  |        |
|-------|--|--------|
| 0.5mm |  | H 8621 |
| 0.8mm |  | H 8624 |
| 1mm   |  | H 8625 |
| 2mm   |  | H 8630 |

#### T-CONNECTORS

- |           |   |        |
|-----------|---|--------|
| 1mm Gauge | T | H 8635 |
|-----------|---|--------|

#### EDGE CONNECTORS

- |              |  |        |
|--------------|--|--------|
| 3.17mm Pitch |  | H 8646 |
|--------------|--|--------|

#### NUMERIC

- |         |   |        |
|---------|---|--------|
| 2.7mm/H | 1 | H 8658 |
|---------|---|--------|

#### ALPHA

- |         |   |        |
|---------|---|--------|
| 3.2mm/H | E | H 8673 |
|---------|---|--------|

#### CREPE DESIGN

- |         |   |        |
|---------|---|--------|
| 3.8mm/H | E | H 8659 |
|---------|---|--------|

#### TAPES

- |        |               |         |
|--------|---------------|---------|
| H 8702 | 0.5mm x 16M   | \$2.95  |
| H 8703 | 1.0mm x 16M   | \$2.95  |
| H 8704 | 1.5mm x 16M   | \$2.95  |
| H 8705 | 2.0mm x 16M   | \$2.95  |
| H 8710 | Pack of any 4 | \$10.00 |

#### ROLL PACKS

Ideal for Trade Users

Contents vary each style as dimensions differ. As a guide doughnuts contents 250 PCs.

#### DOUGHNUTS

- |     |        |        |        |
|-----|--------|--------|--------|
| 2mm | H 8802 | \$3.50 | \$3.25 |
| 3mm | H 8803 | 3.50   | 3.25   |
| 4mm | H 8804 | 3.50   | 3.25   |

#### TEAR DROPS

- |     |        |        |        |
|-----|--------|--------|--------|
| 3mm | H 8830 | \$4.95 | \$4.50 |
| 4mm | H 8840 | 4.95   | 4.50   |

#### T-CONNECTORS

- |       |        |        |        |
|-------|--------|--------|--------|
| 1.6mm | H 8816 | \$5.75 | \$5.50 |
| 2.5mm | H 8825 | 5.75   | 5.50   |

#### IC PADS

- |           |        |        |        |
|-----------|--------|--------|--------|
| 4 x 2.8mm | H 8841 | \$3.50 | \$3.25 |
| 4 x 2.5mm | H 8842 | 3.50   | 3.25   |

FOR NEXT DAY JETSERVICE DELIVERY

# ALTRONICS QUALITY TELEPHONE EQUIPMENT

## Famous Call Master Phone Answering Machines



With Callmaster you'll never miss a call again just because you weren't near the telephone when it rang. Callmaster answers for you, in your own voice if you wish, then records and stores the callers' messages for your convenience.

24 hours a day, 7 days a week, Callmaster is on the job. Your callers will appreciate the chance to communicate their information to you, without enduring the frustration of repeatedly dialling an unanswered number.

### DUAL CASSETTES

This important feature is provided by both A 0516 non remote and A 0515 remote. One cassette delivers your outgoing announcement and the other records incoming messages. Outgoing messages need be recorded once only and incoming messages are stored on the other standard sized cassette and can even be played back on your tape deck or car stereo.

### MONITORING FUNCTION

Enables you to "screen" incoming calls, giving you the option of speaking with the caller personally or allowing your Callmaster to continue recording normally.

### CONDENSOR MICROPHONE

Callmaster features a built-in microphone which records your outgoing messages. Convenient, and can't be lost.

### LARGE INCOMING MESSAGE CAPACITY

Up to 150 messages can be recorded, using a C60 leaderless cassette and based on an average message time of 12 seconds per call.

### EASY CHANGE OF OUTGOING MESSAGES

Your Callmaster endless loop cassette gives a 20 sec. announcement, optional cassettes are available in lengths of 12, 15, 30, 45 or 60 seconds. (If required, your machine can be modified to use 120 seconds outgoing message cassettes.)

### CALLING PARTY CONTROL

Callmaster stops recording the instant your caller hangs up, eliminating annoying blank spots between incoming messages.



Standard Model A 0510 **\$229**

Remote control model A 0515 **\$299**

### REMOTE CONTROL

(A 0515 only)— Receive your messages from any telephone, anywhere in the world! The decoder enables you to command playback of incoming messages from any telephone. You also have the option to remotely rewind the incoming message cassette giving full capacity again or continue to accumulate all incoming messages.

### FAST FORWARD

(A 0515 only)— Whilst playing back your incoming messages, the convenient non-locking fast forward key may be depressed, advancing the incoming message cassette for the required duration.

### PRECISION AND QUALITY

Callmaster is designed especially for Australian telephone conditions and precision manufactured in Japan, assuring unequalled performance and reliability.

### TELECOM

Callmaster A 0510 and A 0515 are both permitted for direct connection to the telephone network. You just plug it in!  
Telecom Australia Permit # C81-16-18.  
Energy Authority of N.S.W. Certificate # CS2029N.

## ALL THESE FEATURES PLUS A FULL 12 MONTHS WARRANTY AGAINST FAULTY WORKMANSHIP OR MATERIALS

## SUPER FONE CORDLESS TELEPHONE

The handset is light, comfortable to use and attractively styled. Absolutely perfect for use around the garden or backyard pool etc. The remote handset tone ringer can be activated remotely from the base unit, providing paging and intercom from a parallel phone.



Cat A 0600 **\$239**

DOC Permit RFM E002/026  
Telecom Permit C83-35-9

**COMMUNICATION RANGE:** Approx. 100m under ideal conditions.

**POWER SUPPLY VOLTAGE:** Base unit AC 240V 50 Hz  
Input 12V DC 300mA  
Remote Telephone DC 4.8V

### BASE RECEIVER:

Frequency (Single Channel)	40.025—40.225MHz
Sensitivity for 20dB Signal to Noise	0.5uV
Adjacent Rejection	+ 15KHz 50dB
	-15KHz 50dB

### REMOTE TRANSMITTER:

Frequency (Single Channel)	40.025—40.225MHz
----------------------------	------------------

### REMOTE RECEIVER:

Frequency (Single Channel)	1.725—1.785MHz
Sensitivity for 20dB S/N	0.5uV
Adjacent Channel Rejection	+ 15KHz 50dB
	-15KHz 50dB

### Consumption Current

Stand-by	less than	8mA
ringer	less than	20mA
during conversation	less than	50mA

### RECHARGEABLE BATTERIES (REMOTE):

Nominal Capacity	250MAH
Nominal Voltage	4x1.2V = 4.8V

## Home Telephone Extension Cords and Adaptors

Now you can have your Telephone in the backyard or just on the other side of the lounge room with these nifty telephone leads. Double Adaptor allow two phones into the one line. Ideal for cordless phones etc.

- P 0990 5 Metre extn.lead **\$14.95**
- P 0992 10 Metre extn.lead **\$17.50**
- P 0995 Phone Dble Adpt. **\$12.50**

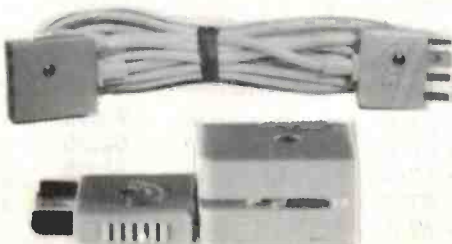

## PUSH BUTTON TELEPHONE

With memory Re-dial  
Great for use as a 2nd phone around the house or office.

A 0490 . . **\$17.50**



BANKCARD HOLDERS—PHONE ALTRONICS TOLL FREE 008 • 999 • 007 FOR NEXT DAY JETSERVICE DELIVERY

BANKCARD HOLDERS—PHONE ALTRONICS TOLL FREE 008 • 999 • 007 FOR NEXT DAY JETSERVICE DELIVERY

# SEMICONDUCTOR DATA BOOKS

## MOTOROLA SEMICONDUCTOR

### MOTOROLA CMOS DATA

A comprehensive reference covering 40XX, 45XX CMOS family's along with speciality devices such as LCD drivers, telephone and general communication functions and industrial control. **862 pages essential in all spheres of electronics.**

B 1105 ..... \$12.95

### SCHOTTKY TTL DATA

Essential reference for the enthusiast and engineer alike. Designing, building and servicing digital circuitry is an absorbing pastime. Data for the LS, ALS and FAST families along with design considerations and circuit characteristics are logically presented in this manual, making it quick and easy to use.

B 1109 ..... \$11.95

### MOTOROLA MEMORY DATA

An absolute must for the microprocessor buff. This is the latest reprint of Motorola's famous memory data manual and includes the latest specifications and design application data on TTL RAM, TTL PROM, MECL MEMORY, MECL RAM, MECL PROM, MOS DYNAMIC RAM, MOS STATIC RAM, MOS EPROM, MOS EE PROM AND MOS ROM. Worth many dollars more.

B 1113 ..... \$11.95

### LINEAR & INTERFACE DATA

Popular data manual. At last readily available. Includes Data design procedures and equivalent listings for 1000's of devices under headings OP AMPS, VOLTAGE REGULATORS CONSUMER CIRCUITS (e.g. TV, automotive power), HIGH FREQUENCY CIRCUITS and SPECIAL PURPOSE CIRCUITS. Gives data, design procedures and equivalent listings for. MEMORY/MICROPROCESSOR SUPPORT, LINE DRIVERS/RECEIVERS, TELEPHONY, COMPARATORS, VOLTAGE REFERENCE AND DATA CONVERSION DEVICES. Includes comprehensive selector guide.

B 1114 ..... \$22.95

### MOTOROLA MECL DATA

Emitter Collector Logic (ECL) is today's fastest form of digital logic providing the most direct way of improving system performance. This previously hard to get manual provides data on the 10KH, 10K and III families, MECL memory and PLL CHIPS.

B 1100 ..... \$11.95

### MOTOROLA POWER DATA

Motorola are the undisputed world leader in power transistors. Renowned for their low cost and reliability. Book includes a 9 page selection guide, application notes and data sheets for over 700 devices. 989 pages.

B 1101 ..... \$19.95

### MOTOROLA MASTER SELECTION GUIDE

The most useful book ever printed. Covers MOS IC's listed by function. LINEAR IC's listed by function. INTERFACE IC's listed by function. LSI memory, TTL, ECL power products. SCR's, diodes, transistors listed by application and ratings. RF, small signal and opto devices listed by application and ratings. Essential data given for all devices. Terrific Value.

B 1104 ..... \$7.95

### MOTOROLA OPTO DATA

Handy reference provides data and application notes on opto couplers, infra red LEDs, photo transistors and a complete chapter on fibre optics, a communications system which is fast gaining usage world wide. Very Educational.

B 1118 ..... \$11.95

### MOTOROLA 8-BIT MICROPROCESSORS AND PERIPHERALS

This manual covers all aspects of Motorola's microprocessor, microcomputer and peripheral components. A clearly written manual providing all the data necessary to design and build a working computer system from scratch. 100's of circuit examples, flow charts, truth tables and programme routines.

B 1125 ..... \$16.95



## NATIONAL SEMICONDUCTOR

### INTERFACE

This databook provides complete specifications for a variety of transmission line drivers/receivers, peripheral/power drivers and level translators/buffers. Product selection guides list applications information and operating features. Memory, dynamic memory, microprocessor, data communications and disk support products are also covered in the data book. The interface appendices section contains cross reference guides; the programmable logic section describes the technology, design and gives application suggestions.

Pages: 1520 Year: 1983

B 1005 ..... \$13.50

5 Up ..... \$12.00

### DATA CONVERSION ACQUISITION DATABOOK

The 1984 edition of the Data Conversion/Acquisition Databook is one of the most comprehensive in the industry. It contains specifications for high technology conversion products in the analog signal path, both preceding and following the conversion process. Combining high volume production capability with leading edge technology such as thin film resistors, laser trimming and advanced micro CMOS and bipolar processing, has helped develop products best suited to your design needs.

Pages: 1232 Year: 1984

B 1007 ..... \$13.50

5 Up ..... \$12.00

### LINEAR DATABOOK

The 1982 edition of the National Semiconductor Linear Databook is the most comprehensive available. It presents approximately 2000 pages of specifications for our high-technology linear products. Applications, descriptions, features and diagrams in this databook include detailed sections for Voltage Regulators, Op Amps, Voltage Comparators, A to D, D to A Converters, Industrial Blocks and Audio and TV Circuits. The databook also features advanced telecommunication devices and speech synthesis (DIGITAL TALKER), plus other non-state-of-the-art linear products offering performance, economy, quality and reliability.

Pages: 1952 Year: 1982

B 1010 ..... \$15.00

5 Up ..... \$14.00

### LINEAR SUPPLEMENT

The 1984 Linear supplement provides the most recent information on National's new linear products. This supplement also provides a comprehensive index published in the Master Databook. New products designed are indicated by an Asterisk and in bold type. Revised data sheets are listed in bold type. National's supplement databook system allows you to make product selections of their latest product offerings.

Pages: 566 Year: 1984

B 1011 ..... \$7.50

5 Up ..... \$6.50

### LOGIC DATABOOK

National's new Logic Databook covers five of their logic families: TTL (54/74) Schottky (54S/74S) low power Schottky (54LS/74LS) high speed (54H/74H) and low power (54L/74L). The Logic Databook—especially organised for quick and easy referencing—offers two complete functional indices and selection guides, one for SSI and one for MSI devices. In addition, it includes over 100 connection diagrams and test waveforms to help speed the design-in cycle. All in all, it's probably the most comprehensive collection of practical information ever assembled on such a broad line of practical components.

Pages: 550 Year: 1981

B 1015 ..... \$11.00

5 Up ..... \$10.00

### MOS MEMORY DATABOOK

The 1984 MOS Memory Databook is a comprehensive collection of information advanced, high-density memory products covering the spectrum of this mainstream semiconductor component category. National Semiconductor has an array of advanced technology processes to apply to memory design and development. These range from high-density triplepoly process used in the most advanced RAMs, the small-geometry, silicon gate, oxide-isolated micro-CMOS technology which is now being applied to high-performance memory devices for the first time.

Page: 256 Year: 1984

B 1025 ..... \$7.50

5 Up ..... \$6.50

### HYBRID PRODUCTS DATABOOK

The Hybrid Products Databook is the only National Semiconductor publication that contains complete information on all our hybrid semiconductor products. Included are precision thin film and thick film products which provide the user with standard functions from operational amplifiers to converters with capabilities beyond those of current monolithic technology. Product selection guides and an application section are also included.

Pages: 792 Year: 1982

B 1045 ..... \$9.95

5 Up ..... \$9.25

### TRANSISTOR DATABOOK

National Semiconductor has added many new transistors and product families since publication of the last databook. Many have already been widely acclaimed by users. In addition to small-signal, power-bipolar and field effect transistors that have been the mainstay of our catalog, there is a section for multiple-field-effect transistors. More part numbers will be added as market needs expand. To keep current on all new National transistors, please contact your National sales representative or franchised distributor and ask to be placed on the customer mailing list.

Pages: 558 Year: 1982

B 1050 ..... \$9.95

5 Up ..... \$9.25

### CMOS DATABOOK—1984

The CMOS Databook contains the industry's most comprehensive collection of high-performance CMOS products available. Our early commitment to micro-CMOS technology has made possible the development of a broad spectrum of advanced devices that will simplify your design and ensure state-of-the-art systems. Micro CMOS technology describes National's array of small-geometry, silicon gate, oxide-isolated processes used to build the products in this book. Using N- or P- well substrates and multiple-layer metal or polysilicon-interconnect structures, micro CMOS processes feature sizes of 3.0, 2.0 or 1.5 microns, with submicron feature sizes in development.

Pages: 1520 Year: 1984

B 1030 ..... \$13.50

5 Up ..... \$12.00

### VOLTAGE REGULATOR HANDBOOK

With the variety of fixed and variable regulator technology currently available, the 336 page Voltage Regulator Handbook becomes a must for the selection of three terminal and dual tracking components that meet the system requirement while utilizing the most cost effective approach. Beginning with product selection procedure and a data sheet summary, the text continues with easily accessible information about booster circuitry, power transformer and filter specifications, test methods, manufacturers' cross reference, and extended use applications for National's regulators.

Page: 336 Year: 1982

B 1055 ..... \$9.95

5 Up ..... \$9.25

## MOTOROLA BONUS OFFER SET OF 9 TITLES

B 9995 ..... \$99.00

**SAVE \$30**

## NATIONAL SEMI BONUS OFFER SET OF 10 TITLES

B 9996 ..... \$89.00

**SAVE \$22**

BANKCARD HOLDERS—PHONE ALTRONICS TOLL FREE 008 • 999 • 007 FOR NEXT DAY JETSERVICE DELIVERY



# Build This

## MULTI SECTOR BURGLAR ALARM STATION

Superb new Kit Project by Electronics Australia.

**K 1900**  
**\$139**

Save \$\$\$  
on the cost  
of commercial  
equivalents

Within the  
Capacity of  
the beginner  
constructor

Professionally  
Engineered by  
the design team  
at Electronics  
Australia

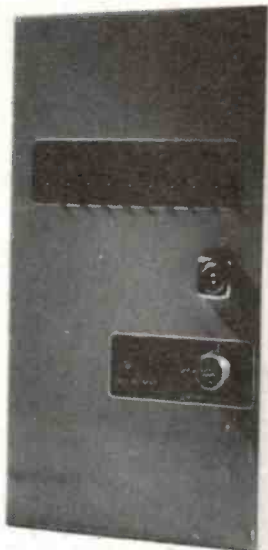

Protect your Home or Business from Intruders with this  
"State of the Art" Burglar Alarm System.

Over the last few years, House Break-ins have increased dramatically—a check of recent police statistics is simply horrifying! The recovery rate of stolen goods is very low. This is partly due to the sheer difficulty in identifying goods as well as the incredible volume of property stolen.

Now more than ever before, it makes extremely good sense to build and install this Ingenious Multi-Sector System.

This unique Alarm System incorporates the features of the more expensive commercial models—at a fraction of the price.

**FEATURES:**

- \* Alarm has 8 separate Input circuits—8 sectors can be monitored independently.
- \* Each input circuit is provided with an indicator LED and a sector On/Off switch
- \* Individual sector isolation allows the user to have some areas of the premises habited while others remain protected e.g. Inside Off/Outside On.
- \* Inputs accept both normally closed and normally open sensors
- \* Two Inputs provided with an entry delay (between 10-75 sec)
- \* Alarm is disabled by front panel key switch
- \* Internal trip warning buzzer—alerts owner/occupant of pending alarm operation—great for the "forgetful" amongst us. This buzzer is pre-settable between 5 and 55 seconds prior to Alarm.
- \* Unique circuit detects automatically when any N/O or N/C loops are either open circuit or dead short e.g. someone trying to bridge reed switches etc.

- \* Automatic muting of the siren driver when under test—so as not to wake the whole neighbourhood.
- \* Fully variable exit delay—between 5 and 45 seconds
- \* Will drive a separate external horn speaker
- \* Alarm output variable between 1 and 15 minutes.
- \* When triggered—gives a switched double pole output for connection to external devices e.g. Bells, TV Camera etc.

- \* Switched output can be used to send a silent alarm through an auto-dialler circuit or similar.
- \* Full battery back up provided via. 12V—1.2Ah battery
- \* Alarm will operate for approx. 2 days with mains disconnected.
- \* Supplied in an attractive functional security case.

K 1900                      A Mere                      **\$139.00**

### Suggested Alarm Accessories for use with the Multi Sector Alarm System

**Weatherproof Horn Speakers**

- 5 and 10 watt
- 5W**  
C 2010 \$9.50  
10Up \$8.90
- 10W**  
C 2015 \$11.50  
10Up \$9.50



**Weatherproof Siren Horn**

- 12V DC  
Deafening  
Siren Wail
- S 5158 \$22.50  
10Up \$20.00



**PIEZO ALARM**

Similar to "Sonalert" type. Absolutely ear piercing sound. Recommended voltage 5—15V DC. Ideal for almost all audio signalling applications. I.e. Fire, water and gas signalling, computer alarms, etc.

- S 5166 \$4.95  
10Up \$4.50



**DUAL FUNCTION**

Same physical dimension as S 5066. Gives either a pulsed output (siren) or a continuous tone. 3 wire connection enables selection of either output.

- S 5170 \$5.95  
10Up \$5.00

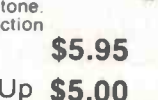

**Pressure Mats**

Ultra thin switch mat for under carpet or mat etc.

- S 5184 \$19.95  
10Up \$17.50ea



**Reed Switch and Magnet Sets**

- 3 Types (Surface Mount)
- S 5155 N/C SW \$2.50 2.20  
S 5156 N/O SW \$2.95 2.10  
S 5153 SPDT \$2.98 2.59
- Changeover type



**NEW Concealed Reed Switch and Magnet Set**

Simply brilliant! Just drill recess your door or window and the magnet is flush mounted and thus "invisible". The Reed Switch segment is similarly mounted into the door frame or window frame and wired into your system.

- Can't be tampered with Professional Quality
- S 5152 \$3.98  
10Up 3.50 ea



**Fig '8' Cable**  
Ideal for runs to and from pressure mats, sirens, reed switches, horn speakers or just about anything low voltage

- W 0200 2 x 14/14 .20¢ per/M  
Grey and Black \$10.00 per 100M Roll



**Security Key Switches**

- Standard Type**  
Includes 2 Keys
- High Security Type**
- 4 Pole 2 Position
- S 2500 \$4.95      S 2510 \$5.50  
10Up \$4.10      10Up \$5.00



**ULTRASONIC TRANSDUCERS**

- S 5110 \$9.90 pr.  
D=16mm H=12mm



Ultrasonic transmitter and receiver transducers operating at 40KHz + or - 1KHz. Perfect for security applications etc. i.e. alarm sensors, counting sensors, remote control sensors and many other uses.

Sensitivity TX 106db RX -65db Dispersion angle 20 deg. Max Input voltage 20V RMS Impedance TX 500 Ohms RX 30K Ohm. Operating range up to 9M

Please Note only sold as Matched Pairs of RX, TX

**MINI BUZZER 5-15V DC**

Handy little solid state low current buzzer is ideal for use with signalling panels, alarm systems, in the car etc.

- S 5162 \$1.95

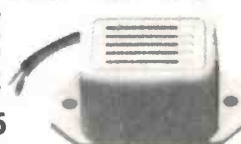

BANKCARD HOLDERS—PHONE ALTRONICS TOLL FREE 008 • 999 • 007 FOR NEXT DAY JETSERVICE DELIVERY

## BLOOD PRESSURE & HEART RATE MONITOR

### Why Risk Unnecessary Heart Attack?

A simple (take the reading yourself) periodic check of your blood pressure and pulse provides an "inward look" into a vital aspect of your bodily health. Heart disease strikes down many people in their early 40's (or even 30's). The tragedy remains that had such victims been alerted, remedial medical, physical and dietary action could have been prescribed to avoid illness and in many cases restore full bodily health.

A Superb Gift for the dedicated fitness enthusiast **Absolutely essential** for those over 40 and concerned with their health, or on Fitness Therapy. Use this **easy to operate** Monitor to measure your pulse (or heart rate) and Blood Pressure.

**DON'T PAY \$150**

X 3055

**Now Only \$89**

Remember high blood pressure is in itself symptomless and the usual forerunner to future chronic heart disease. Features include "error" display warning of incorrect use. Handbook supplied will enable anyone in your family to be fully conversant with this monitor in minutes. Easy to read display of Systolic and Diastolic Blood Pressure and Pulse Rate.

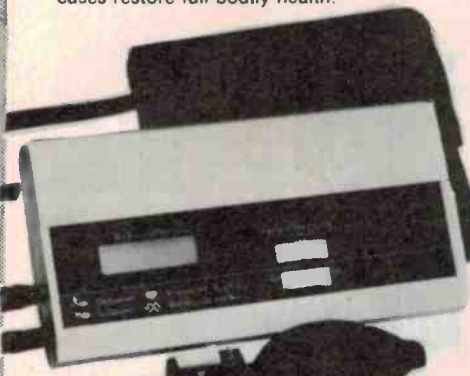

## PROFESSIONAL SERIES RACK CABINETS

NOW YOUR PREAMPS, AMPS, CONTROL MODULES MONITOR PANELS ETC. CAN LOOK EVERY BIT AS GOOD AS TECHNICS, NAKAMICHI AND OTHER TOP MANUFACTURERS

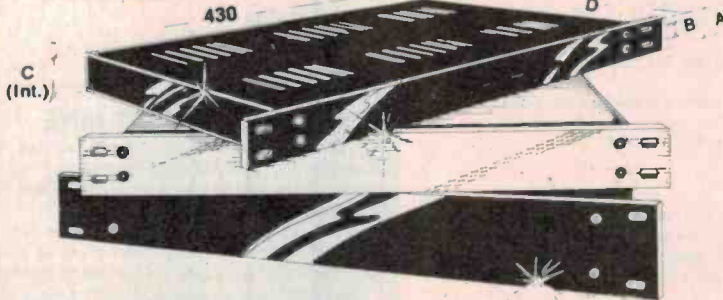

**FEATURES:**—• These beautifully crafted rack cabinet boxes will give your equipment a real 1st class appearance • Aluminium construction with removable top and bottom steel cover panels • All dimensioning conforms to the International Standard • Natural or Black finish • Ventilated lid • Deluxe finish front panel • Individually cartoned • Supplied in Flat Pack Form—Easily assembled in minutes—**Slide Elevations:**—• D= 254mm C (Internal Chassis Height) • B (Mounting Bolt Centres).

### SIX NATURAL AND BLACK FINISH MODELS

The Black or Natural finish cabinets are each available in 44mm, 88mm or 132mm high models. Mounting hole centres conform exactly to International Racking Specifications both vertically and horizontally.

Cat. No.	Finish	A	B	C	ea.	5+
H 0401	Natural	44	34	38	\$45.00	\$42.50
H 0402	Natural	88	57	82	55.00	52.50
H 0403	Natural	132	89	126	59.95	55.00
H 0411	Black	44	34	38	45.00	42.50
H 0412	Black	88	57	82	55.00	52.50
H 0413	Black	132	89	126	59.95	55.00

## 30 WATT LINE OUTPUT PUBLIC ADDRESS AMPLIFIER

with balanced

Mic Input and Muting

A 2000

**\$199.50**

2 year

Warranty



Developed right here in Australia by leading Audio Designer Giuseppe Iacusso — the Altronic A 2000 utilizes balanced input, drive output and feedback circuitry to achieve performance and stability unheard of with low cost amplifiers. The A 2000 will operate happily into all sorts of capacitive and inductive loads. Long lines, speaker transformers etc. Eminently suited for use by Schools, sporting clubs, function centres as well as with professional installations (paging systems—background music).

### SPECIFICATION:

• **Balanced Low Impedance Mic Input** 200—600 ohm. Input socket 5 Pin Din (Line 1 and 3, 2 earth) • **Unbalanced Low Impedance Mic Input** 200—600 ohm (Line 1, 3 and 2 earth) • **Mic Muting** on Pins 4,5. Mutes auxiliary channel (or music programme) when operated. • **Auxiliary Input** 100K ohm RCA • **Treble and Bass Controls** Individual boost and cut controls provided for auxiliary channel only • **Low Z Speaker Output** 4—16 ohm • **Line Output** 100V line (balanced) • **Power Output** Full 30 watts RMS into either 4 ohm or 100V line • **Distortion** typically less than 1% • **Frequency Response** 60Hz to 12KHz

# ALTRONICS

COMPONENTS

105 STIRLING STREET, PERTH  
FOR INSTANT SERVICE  
PHONE ORDER TOLL FREE  
008 999 007  
PERTH METRO AND A/HRS  
ORDERING SERVICE  
(09) 328 1599

All Mail Orders  
Box 8280, Stirling St. Perth WA 6000

### PACKING AND DELIVERY CHARGES

**\$3.00 Delivery Australia Wide** - We process your order the day received and despatch via Australia Post. Allow approx. 7 days from day you post order to when you receive goods. Weight limited 10kgs.

**\$5.00 Overnight Jetservice** - We process your order the day received and despatch via overnight jetservice Courier for delivery next day Country areas please allow additional 24-48 hours. Weight limit 3kgs.

**\$10.00 Heavy Heavy Service** - All orders of 10kgs or more must travel express Road - Please allow 7 days for delivery.

**Insurance** - As with virtually every other Australian supplier, we send goods at consignees risk. Should you require comprehensive insurance cover against loss or damage please add 1% to order value (minimum charge \$1) When phone ordering please request "Insurance".

**Toll Free Phone Order** - Bankcard Holders can phone order toll free up to 6pm Eastern Standard Time. Remember with our Overnight Jetservice we deliver next day.

### ALTRONICS RESELLERS

Wanted in all Areas of Australia—Phone Steve Wroblewski on (09) 381 7233 for Details.

NSW	TASMANIA	VICTORIA
<b>CITY</b> David Reid Electronics ... 267 1385 Jaycar ... 264 6689 Radio Dispatch 211 0191	<b>NEWCASTLE</b> D.G.E Systems 69 1625 George Brown & Company ... 69 6399	<b>CITY</b> Active Electronics ... 602 3499 All Electronic Components ... 662 3506 MaGraths Electronics ... 347 1122
<b>SUBURBAN CARLINGFORD</b> Jaycar ... 745 3077	<b>NOWRA</b> Southern Communications 21 4011	<b>SUBURBAN BENTLEIGH</b> Absolute Electronics ... 557 3971
<b>DEE WHY</b> David Ryall Electronics ... 982 7500	<b>ORANGE</b> MW Electronics. 626 491	<b>BOX HILL SOUTH</b> Eastern Communications 288 3107
<b>HURSTVILLE</b> Jaycar ... 570 7000	<b>PENRITH</b> Acorn Electronics 21 2409	<b>CHELTENHAM</b> Talking Electronics ... 550 2386
<b>LEWISHAM</b> Jaycar ... 569 9770	<b>PORT MACQUARIE</b> Hall of Electronics 83 7440	<b>DONCASTER</b> Cligstone Electronics 842 8768
<b>MATTRAVILLE</b> Creative Electronics ... 666 4000	<b>RAYMOND TERRACE</b> Altrac Electronics 87 3419	<b>FOOTSCRAY</b> Acron Electronics 689 1911
	<b>RICHMOND</b> Vector Electronics 78 4277	<b>SOUTH CROYDON</b> Truscott Electronics ... 723 3860
	<b>TAMWORTH</b> Landline Communications 65 4622	<b>COUNTRY</b> Nathan Ross ... 36 2204
	<b>TERNTERFIELD</b> Nathan Ross ... 36 2204	
<b>ALBURY</b> Webb's Electronics 25 4066	<b>TOUKLEY</b> IES Electronics 96 4144	<b>BENDIGO</b> M & E Electronics ... 41 1411
<b>BATHURST</b> The Electronics Shop ... 31 4421	<b>WINDANG</b> Mediant Electronics ... 96 5066	<b>MILDURA</b> Electronic and Digital Services 23 3380
<b>BROKEN HILL</b> Crystal TV ... 4803	<b>WINDSOR</b> M & E Electronics Communications 77 5935	<b>MOREWELL</b> Morewell Electronics ... 34 6133
<b>COFFS HARBOUR</b> Coffs Harbour Electronics ... 52 5684	<b>WOLLONGONG</b> Newline Electronics ... 27 1620	<b>SHEPPARTON</b> GV Electronics 21 8866
<b>GOSFORD</b> Tomorrow's Electronics ... 24 7246	<b>VIMCOM</b> Electronics ... 28 4400	
<b>KURRI KURRI</b> Kurri Electronics 37 2141		
<b>QUEENSLAND</b>	<b>SA</b>	<b>WA</b>
<b>CITY</b> DeSound P/L 2296155	<b>CITY</b> Force Electronic 212 2672 Protronics ... 212 3111	<b>COUNTRY</b> BP Electronics ... 41 2681
<b>SUBURBAN FORTITUDE VALLEY</b> McGraths Electronics ... 832 3944	<b>Gerard &amp; Goodman 223222</b>	<b>ESPERANCE</b> Esperance Communications 71 3344
<b>SL LUEDA</b> Electronics 523547	<b>BRIGHTON</b> Brighton Electronics 296 3531	<b>GERALDTON</b> K B Electronics & Marine ... 21 2176
<b>SALISBURY</b> Colourview Wholesale ... 2753188	<b>CHRISTIES BEACH</b> Force Electronics 382 3366	<b>KALGOORLIE</b> Todays Electronics 21 2777
<b>SLACKS CREEK</b> David Hall Electronics ... 2088808	<b>KESWICK</b> Freeway Electric Wholesalers ... 297 2033	<b>MANDURAH</b> Kenitronics ... 35 3227
<b>TOOWONG</b> EQC Technics ... 3710870	<b>PROSPECT</b> Jensen Electronics ... 269 4744	<b>WYALKATCHEM</b> D & J Pease ... 81 1132
	<b>REYNELLA</b> Force Electronics 381 2824	
<b>COUNTRY</b>	<b>COUNTRY</b>	<b>NT</b>
<b>CAIRNS</b> Thompson Instrument Services 5 12404	<b>MT. GAMBIE</b> South East Electronics ... 250 034	<b>DARWIN</b> Ventronics ... 81 3491
<b>BUNDBERG</b> P.H. Electronics ... 726 272	<b>PT. LINCOLN</b> West Coast Elect Supplies 82 5802	<b>ALICE SPRINGS</b> Alcom Electronics ... 52 1713
<b>GLADSTONE</b> Purley Electronics 724231	<b>WHYALLA</b> Eye Electronics ... 45 4784	<b>FARMER</b> Electronics ... 52 2967
<b>NAMBOUR</b> Nambour Electronics ... 411604	<b>TASMANIA</b>	
<b>PALM BEACH</b> The Electronic Centre ... 341248	<b>CITY</b> D & J Agencies ... 34 7677	
<b>ROCKHAMPTON</b> Purley Electronics 21058	<b>GEORGE HARVEY</b> Hobart ... 34 2233	
<b>TOOWOOMBA</b> Hunt Electronics 329677	<b>LAUNCESTON</b> Launceston ... 31 6533	
<b>TOWNSVILLE</b> Solar ... 722015		

BANKCARD HOLDERS—PHONE ALTRONICS TOLL FREE 008 • 999 • 007

FOR NEXT DAY JETSERVICE DELIVERY

```

10 PRINTCHR$(14)"MYSTERY SHIP"BY P.BAGUST"
20 PRINT"YOU'VE BEEN TELEPORTEONTO A SPACESHIP ABOUTTO COLLIDE WITH EARTH. ST
OP IT!"
30 P=2:M=11:T=-1:L=3:K=10:S=12:V=36878:W=36877:X=36874:TIS="000000"
40 PRINT"YOU'RE IN THE"ONPGOTO310,320,330,340,350,360,370,380,390,400,410,420
50 POKEV+1,C:IFL<0THENL=-P:PRINT"CARRYING LAZER"
60 IFU=4ANDP=2THENPRINT"TELEPORT ACTIVATES AND THEN SUDDENLY..."GOTO870
70 IFK<0THENK=-P:PRINT"GET KEY"
80 IFS<0THENS=-P:PRINT"WEARING SPACESUIT"
90 IFM<0THENM=-P:PRINT"A VERY NASTY ALIEN IS RUNNING AT YOU!!"GOTO850
100 PRINTTAB(16)TIS
110 IF TIS>"003000"THENPRINT"TIME UP-SHIP CRASHES!"GOTO830
120 IF T>-1ANDS=-PTHEN T=1:PRINT"OXYGEN UNITS LEFT":IFT=0THENS=0
130 PRINT"WHAT NOW?"
140 GETIS:IFIS=""THEN140
150 IFF=MTHENM=-P
160 IFIS="E"THENA=1:ONPGOTO650,670,670,670,650,670,660,670,780,650,660,670
170 IFIS="W"THENA=-1:ONPGOTO670,660,670,670,670,650,670,660,650,670,650,650
180 IFIS="N"THENA=-3:ONPGOTO670,670,670,650,650,660,670,650,670,650,650,670
190 IFIS="S"THENA=3:ONPGOTO650,650,650,670,650,650,650,650,650,670,670,670
200 IFIS="F"ANDL<X-PTHENPRINT"HAVE NO WEAPON":GOTO130
210 IFIS="F"THENGOTO790
220 IFM=-PTHENPRINT"NOT QUICK ENOUGH ALIEN KILLS YOU!!"GOTO900
230 IFIS="X"THENONPGOTO510,520,530,550,570,590,590,590,610,620,590,640
240 IFIS="O"ANDK=-PTHENGOTO680
250 IFIS="D"THENPRINT"NEED KEY":GOTO50
260 IFIS="C"THENGOTO740
270 PRINT"OPERATE ONE KEY ONLY! E-EAST W-WEST F-FIRE N-NORTH S-SOUTH"
280 PRINT"O-OPEN X-EXAMINE C-CARRY AND/OR WEAR."GOTO40
310 C=232:PRINT"BLACK OF SPACE,000R E HOLE IN HULL S":GOTO50
320 PRINT"TELEPORT ROOM,CAN GO S OODR W":C=253:GOTO50
330 PRINT"ARMS LOCKER . OODR S":IFF=3ANDL=3THENPRINT"LAZER ON THE FLOOR":C=202:G
OTO50
340 PRINT"CONTROL ROOM,HOLE N THERE IS WRECKED MACH-INERY EVERYWHERE":C=174:G0
T050
350 PRINT"CREW ROOM,CAN GO N,S,E THERE IS GRAFFITI":C=187:GOTO50
360 PRINT"ARMOURY,CAN GO W,S CABINET N":C=156:GOTO50
370 PRINT"STORE ROOM,CAN GO S DOOR E":C=171:GOTO50
380 PRINT"CORRIDOR,CAN GO N,S DOOR W":C=204:GOTO50
390 PRINT"SLEEPING ROOM,CAN GO N LAUNDRY CHUTE E":C=218:GOTO50
400 PRINT"LAUNDRY,CAN GO TO N,E MANY THINGS ON FLOOR":C=25:GOTO50
410 PRINT"ESCAPE BAY-NO LIFEBOAT CAN GO N,W,LOCKER E":C=202:GOTO50
420 PRINT"SUIT LOCKER,CAN GO W THERE IS A SPACESUIT":C=233:GOTO50
510 PRINT"HOLE MADE BY METEOR":GOTO50
520 PRINT"DOOR IS MARKED AIRLOCK":GOTO50
530 IFL=3ORL=-3THENPRINT"LAZER HAS ONLY 1 CLIP":GOTO50
540 PRINT"NOTHING HERE!":GOTO50
550 IFU=4THENPRINT"DESTRUCT SWITCH CLOSED":GOTO50
560 PRINT"DESTRUCT SEQUENCE HAS COMMENCED'ABANDON SHIP":GOTO50
570 PRINT"IT READS-HIT BY METEOR CONTROL ROOM DAMAGED"
580 PRINT"SHIP WILL HIT PLANET AT 003000! P.S. BEWARE THE ALIEN!":GOTO50
590 IFU<PTHENPRINT"LOCKED-NEED A KEY":GOTO50
600 PRINT"DOOR IS UNLOCKED!":GOTO50
610 PRINT"CHUTE IS VERY STEEP":GOTO50
620 IFF=KTHENPRINT"THERE IS A KEY!":GOTO50
630 PRINT"NOTHING OF INTEREST!":GOTO50
640 PRINT"SUIT HAS 15 AIR UNITS":GOTO50
650 PRINT"OK":P=P+A:GOTO40
660 IFU=PTHEN650
670 PRINT"CANT DO THAT":GOTO50
680 PRINT"OK":U=P:POKEV,15:B=0:FORY=128T0255STEP1:POKEV,Y:FORZ=1T0100:NEXTZ:B=B
+1
690 IFB=3THENB=0:POKEV,0
700 NEXTY:POKEV,0:POKEV,0
710 IFF=2THENPOKEV,15:POKEV,170:POKEV,240:FORY=1T02000:NEXTY:POKEV,0:POKEV,0:POK
EW,0:Z=1
720 IFZ=1ANDS<X-PTHENPRINT"ALL AIR SUCKED THROUGH AIRLOCK-YOUR DEAD":GOTO800
730 GOTO40
740 IFF=LTHENL=-P:PRINT"OK":GOTO130
750 IFF=RTHENR=-P:PRINT"OK":GOTO130
760 IFF=STHENS=-P:T=15:PRINT"OK":GOTO130
770 PRINT"NO CAN DO":GOTO130
780 PRINT"UNHEEHEHEHEHE":GOTO650
790 POKEV,9:FORY=1T030:FORZ=250T0240STEP-1:POKEV,-2,2:NEXTZ:FORZ=240T0250:POKEV,-2
,2:NEXTZ
800 POKEV,-2,0:NEXTY:POKEV,0
810 IFL=MTHENPRINT"ALIEN AND LAZER BOTH DISINTERGRATE":L=0:M=6:GOTO130
820 PRINT"BACKLASH KILLS YOU"
830 POKEV,-1,220:FORY=15T00STEP-1:POKEV,1:FORZ=1T0300:NEXTZ:NEXTY:POKEV,0:POKEV,-1
,0
840 GOTO300
850 POKEV,15:FORY=1T010:POKEV,200:FOPZ=1T010:NEXTZ:POKEV,0:FOPZ=1T0100:NEXTZ:HEX
T,
860 GOTO100
870 FORZ=1T0999:NEXT
880 POKEV,15:FORY=1T0100:POKEV,INT(PNDV1)+128+128:FOPZ=1T0100:NEXTZ:NEXTY
890 PRINT"CONGRATULATIONS! YOUR MISSION SUCCEEDED YOU HAVE OUR GRATITUDE"
900 POKEV,0:POKEV,0:PRINT"GO TO LIVE AGAIN! PPS: P"
910 GETPS:IFPS=""THEN910
920 IFF="F"THENIFU:

```

## MYSTERY SHIP

P. C. Bagust, Sans Souci NSW

This is a rather interesting adventure game, in which you are invited to teleport onto a space ship that is drifting helplessly near earth. Unless you can stop it, it will crash into the earth, killing many people in the process.

The intrepid adventurer must explore the dark passageways of the ship, encounter hostiles, control the ship and finally earn the gratitude of the peoples of Earth.

## VIC-20

4k7

Q1



## CONTRIBUTORS PLEASE NOTE

All contributions to this column should be accompanied by a listing of the program from a printer. Hand written or typed listings are not acceptable.

There are two reasons for this. The first is that a listing from your computer gives us some guarantee that you have got the listing correct.

Secondly, if you present us with a neat final copy of your program we can use photographic techniques to reproduce it in the magazine, without risk of errors.

However, if you present us with a scrawl done on the back of someone's old fag packet it needs to be manually typed twice here, with consequent increase in labour on our part and increase in the probability of errors.

## GRAPHICS CLOCK

B. Federsen, Ferntree Gully Vic 3156

This program requires and demonstrates some of the capabilities of the Super Expander. It depicts a clock face with a sweep second hand that shows the time. The clock ticks when the time is updated.

In statement 30 the clock has been defined as an ellipse but appears as a circle on the TV screen. Statements 120 to 230 sets the outer points for the second hand and uses a subroutine for drawing the second hand.

## VIC-20





## VIC-20 TWO STICK

### JOYSTICK CONTROLLER

R. Nottage, Forrestfield WA 6058

Here is a simple circuit to give VIC-20 users the ability to play joystick games with two controls simultaneously. IC1 is a quad CMOS switch (4016). The two controls are simply switched under software control. Q1 is used as an inverter, and switches SWA and SWB off when SWC and SWD are switched on, and vice versa. PB1 and PB3 are fire buttons. PB2 and PB4 are extra for other uses such as bomb fire.

To control which joystick is in use:

- POKE location 37139 with 4 to make Joy 0 an O/P and Joy 1, Joy 2 and L/Pen Inputs.
- POKE location 37154 with 127 to make Joy 3 an input.
- POKE location 37137 with a high In bit 2 to switch on JS1 or a low for JS2.
- PEEK bits 3, 4 and 5 for values for PBs 1-3.
- PEEK 37152 in bit 7 for PB4.
- Digital value for selected joystick is in 36871 for X value and in 36872 for Y value.

Joystick values are 100k and C1 to C4 are .001  $\mu$ F.

(NOTE: Some joysticks' resistance range can differ due to mechanical construction. The capacitor for that particular resistance can be changed to counteract this problem.)

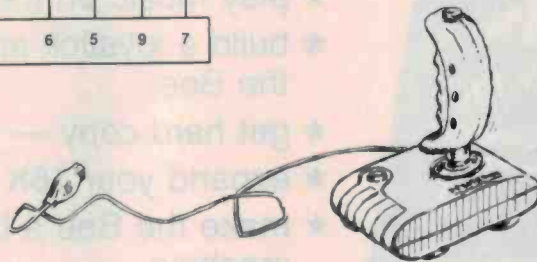
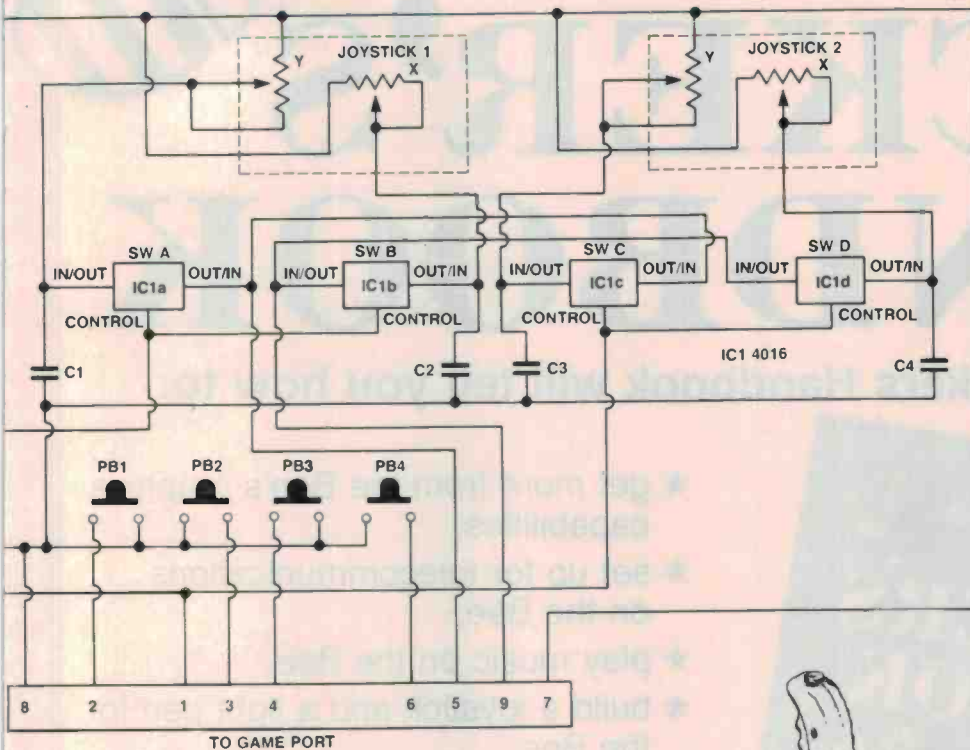

PIN No.	FUNCTION
1	JOY0
2	JOY1
3	JOY2
4	JOY3
5	POT Y
6	LIGHT PEN
7	+5V (100 mA Max)
8	GND
9	POT X

```

10 REM GRAPHIC CLOCK
11 REM REQUIRES SUPER EXPANDER
12 GRAPHIC 0
14 INPUT "GIVE TIME 'HHMMSS' " : A# : TI# = A#
16 GRAPHIC 1
20 COLOR 1,7,0,10
30 CIRCLE 2,511,511,200,300,REM THIS WILL
   APPEAR AS A CIRCLE ON TV
50 REM DRAW CORNER BONES
60 DRAW1,0,0TO100,100
65 X=000:Y=100
69 DRAW5,0,NT0Y,NT0Y,NT0X,NT0X,K
71 A=923:B=100:C=100:D=0
72 DRAW5,A,CT0A,ET0C,ET0C,CT0A,D
73 DRAW1,C,CT0A,E
75 DRAW5,A,AT0C,AT0C,CT0A,CT0A,A
76 DRAW1,C,CT0A,A
77 DRAW5,D,AT0B,AT0B,CT0C,CT0C,A
78 DRAW1,D,CT0B,A
80 DRAW1,0,0TO100,100
85 N=100:Y=923
90 DRAW5,N,NT0Y,NT0Y,NT0X,NT0X,K,REM DRAW MAIN BGN
91 PRINT 3,511,511
92 PRINT 3,200,200
95 REM SET CLOCK NUMBERS
96 CHAR1,09,"12"
97 CHAR13,09,"8"
98 CHAR09,08,"9"
99 CHAR09,13,"3"
101 REM SET SECOND HAND OUTER COORDINATES
102 S=511-000:Y=511-300
104 U=511-410:V=511-313
106 W=511-394:P=511-400

```

```

108 R=511-390:Q=511-280
110 J=S+0,K=T-Q
115 TT=TI:TS=TI+63
120 L=S+0:M=T-Q:GSUB10000:REM 12 O'CLOCK
130 L=S+U:M=T-U:GSUB10000:REM 1 --
140 L=S+W:M=T-P:GSUB10000:REM 2 --
150 L=S+R:M=T=0:GSUB10000:REM 3 --
160 L=S+W:M=T=P:GSUB10000:REM 4 --
170 L=S+U:M=T=U:GSUB10000:REM 5 --
180 L=S+0:M=T=Q:GSUB10000:REM 6 --
190 L=S-U:M=T=U:GSUB10000:REM 7 --
200 L=S+W:M=T=P:GSUB10000:REM 8 --
210 L=S+R:M=T=0:GSUB10000:REM 9 --
220 L=S+W:M=T=P:GSUB10000:REM 10 --
230 L=S-U:M=T=U:GSUB10000:REM 11 --
240 GOTO120
999 END

```

```

10000 REM DRAW ROUTINE
10005 TT=TT+5
10010 IFT1<TT THEN10020
10020 DRAW5,011,509TO3,K
10040 J=L:K=R
10050 DRAW1,011,509TO3,K
10060 POINTS,011,509
10061 IFT3<TI THEN10170
10085 TS=TS+60
10088 AA#MID$(TI#,1,2)+":":MID$(TI#,3,2)+":":MID$(TI#,5,2)
10070 CHAR19,8,AA#
10080 SOUND225,225,225,0,15
10090 SOUND0,0,0,0,0
10170 RETURN

```

# Microbee HACKER'S HANDBOOK



The Microbee Hackers Handbook will tell you how to:

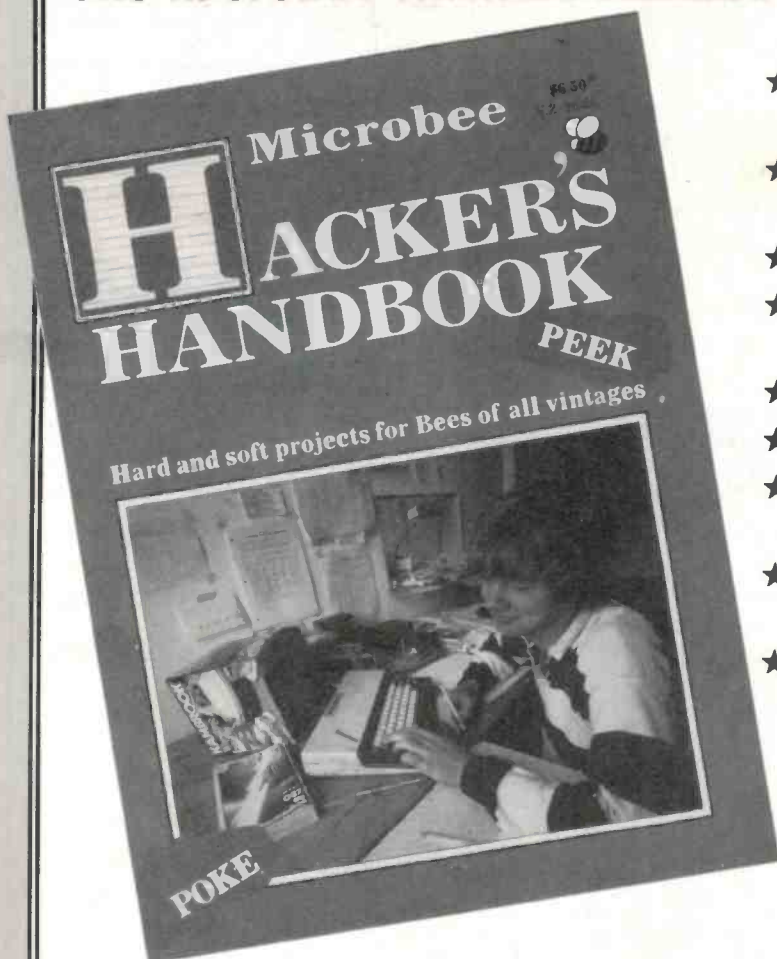

- ★ get more from the Bee's graphics capabilities,
- ★ set up for telecommunications on the Bee,
- ★ play music on the Bee,
- ★ build a joystick and a light pen for the Bee,
- ★ get hard copy — cheaply,
- ★ expand your 16K Bee to 32K,
- ★ make the Bee a better games machine,
- ★ turn your Bee into a facsimile decoder,
- ★ solve equations on the Bee  
... and much more!

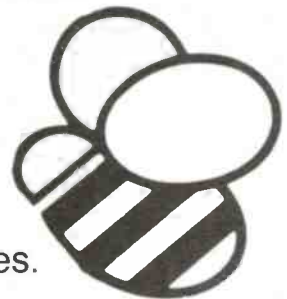

From the publishers of 'ETI' and 'Your Computer' magazines.

We've also included listings of the Bee's BASIC scratch area and machine language locations — to make the Hacker's pursuits easier.

For sociable Hackers there are the contact addresses and phone numbers of all known Microbee user groups.

**\$6.50 Aust. (\$6.95 NZ) at your local newsagent.**

**KIKUSUI**

KIKUSUI ELECTRONICS CORP.

**PERFORMANCE QUALITY VALUE**

Number 4 in worldwide scope sales

Introducing . . .

**cos 5000 SERIES OSCILLOSCOPES**

\* KIKUSUI puts great features within the scope of your budget!

**\$1,999**  
excluding  
S.T.

**KIKUSUI COS 5100****cos 5100 100MHz DELAY SWEEP**

- 3 Channel, 8 Trace display.
- Compact easy to operate 100 MHz CRO with Large, high intensity CRT (Dome-mesh type, 18kV).
- Amazing TRIPPLE TRIGGER function: Ch1, CH2 or VERT. MODE, which triggers both CH1 & CH2 if the signals are not time related.

**FEATURES:**

- + 100 MHz, 5mV/DIV (1mV/DIV x 5 MAG)
- + 2nSEC max. sweep speed (x 1V MAG)
- + Built-in DELAY LINE
- + Linear Focus Circuit eliminates need to refocus during use.
- + Variable HOLD-OFF and LEVEL LOCK

**2 PROBES**  
10:1, 1:1  
included

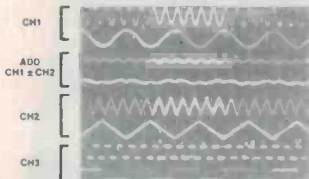

**3 CHANNEL, 8 TRACE DISPLAY,** displayed simultaneously or in selected combination.

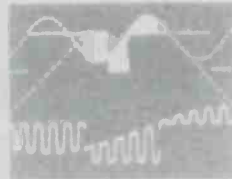

**ALTERNATING SWEEP FUNCTION** provides simultaneous display of both magnified wave and original wave.

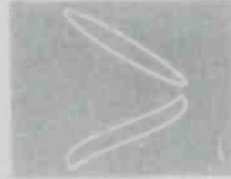

**DUAL X-Y OPERATION** simultaneously with CH3 as X-axis and CH1 & CH2 as Y-axis

**cos 5041 40MHz DELAY SWEEP****KIKUSUI COS 5041**

**\$951**  
excluding  
S.T.

- 12 Months Warranty
- Low power consumption circuitry

Wide application CRO with delayed sweep. Clear display due to Dome-mesh type, 12kV P.D.A. circuit. For lab's, production line & service.

**FEATURES:**

- 40MHz, 5mV/DIV (1mv x 5 MAG)
- 20nSec. max. sweep speed (x 10 MAG)
- Built-in DELAY LINE
- Variable HOLD-OFF and TRIGGER LOCK

**2 PROBES**  
10:1, 1:1  
incl.

**cos 5020 20MHz LOW COST****KIKUSUI COS 5020**

**\$525**  
excluding  
S.T.

★ UNDER N.S.W. GOVT. CONTRACT (No. 83/661)

*That's KIKUSUI Quality!*

Low cost High performance. Compact and easy to operate. ADD (CH1 ± CH2) mode. CH1 signal output. For education, maintenance & field service.

**FEATURES:**

- 20MHz, 5mV/DIV (1mv x 5 MAG)
- 20nSec. max. sweep speed (x 10 MAG)
- Newly designed TV Sync. circuit
- Variable HOLD-OFF and TRIGGER LOCK

**2 PROBES**  
10:1, 1:1  
incl.

**AVAILABLE FROM:****EMONA INSTRUMENTS**

A division of Emona Enterprises Pty. Ltd.

1st Floor  
720 George St  
Sydney, 2000.  
Phone: (02) 212-4599

**DAVID REID ELECTRONICS**

127 York St,  
Sydney, 2000  
Phone: (02) 267-1385

**GEOFF WOOD ELECTRONICS**

656A Darling St,  
Rozelle, 2039.  
Phone: (02) 810-6845  
(one door from National Street)

# ELLISTRONICS

PTY.  
LTD.

MELBOURNE (03) 561 5844 SYDNEY (02) 922 3220

TELEX AA37758 LSTRON

HEAD OFFICE: 797 SPRINGVALE RD. MULGRAVE, MELBOURNE, VICTORIA 3170

## $\mu$ A5 156 A-Law Comanding Codec Telecommunication Products

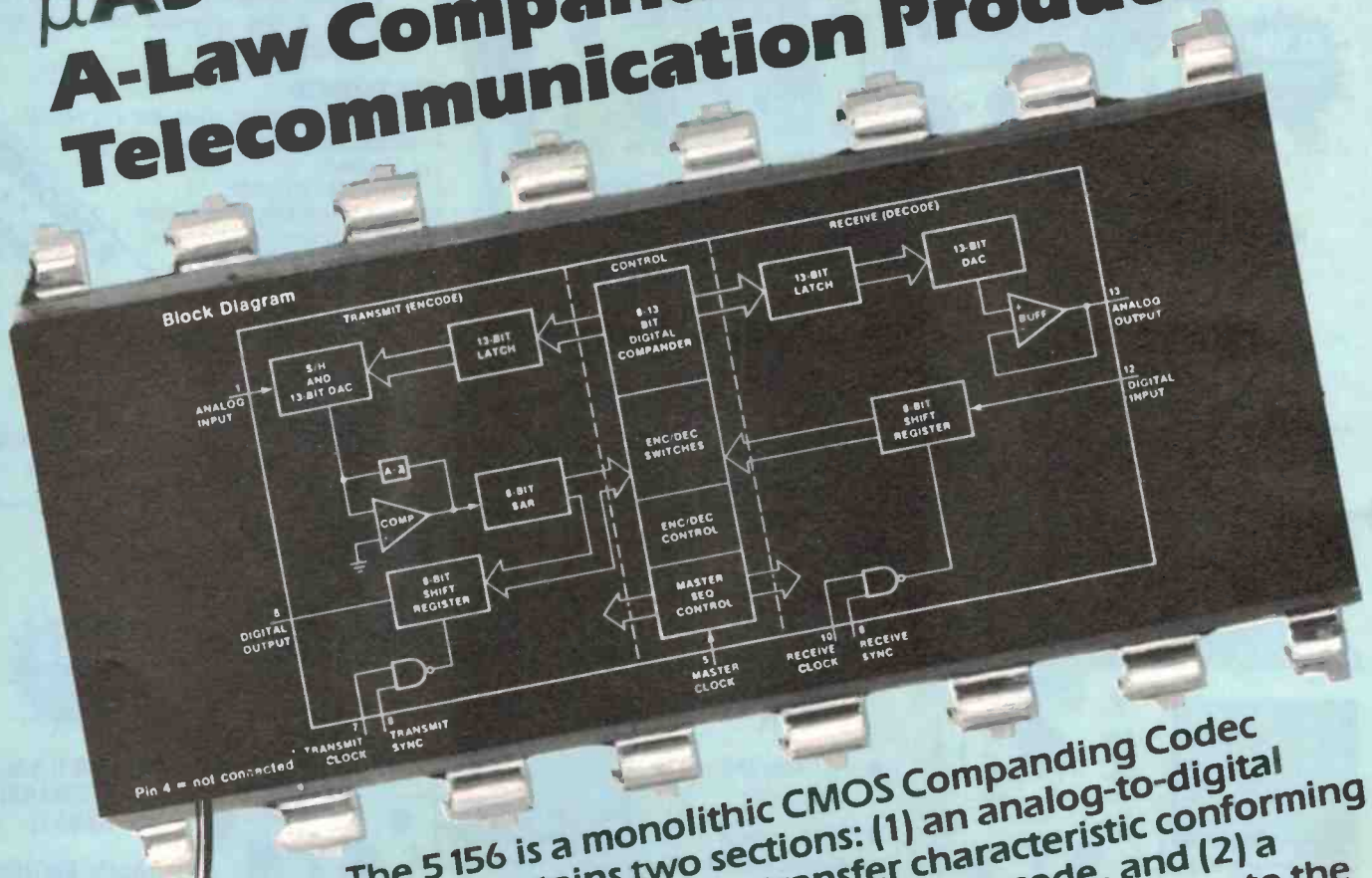

The 5 156 is a monolithic CMOS Comanding Codec which contains two sections: (1) an analog-to-digital converter which has a transfer characteristic conforming to the standard A-Law comanding code, and (2) a digital-to-analog converter which also conforms to the A-Law code.

■ EXCEEDS CCITT SPECIFICATIONS ■ EVEN-ORDER BIT  
INVERSION DATA FORMAT ■ LOW POWER DISSIPATION  
30mW TYPICAL ■ SYNCHRONOUS/ASYNCHRONOUS  
OPERATION ■ ON-CHIP S/H CIRCUIT ■ ON-CHIP OFFSET  
NULL CIRCUIT ■ SEPARATE ANALOG AND DIGITAL  
GROUNDS ■ 64 kb/s TO 2.1 Mb/s SERIAL  
DATA RATE ■  $\pm 5$  V POWER SUPPLY

**\$23<sup>55</sup>**

# ELLISTRONICS

PTY.  
LTD.

MELBOURNE (03) 561 5844 SYDNEY (02) 922 3220  
TELEX AA37758 LSTRON

HEAD OFFICE: 797 SPRINGVALE RD. MULGRAVE, MELBOURNE, VICTORIA 3170

## REGULATORS

Device	Description	Price
UA494PC	Pulse Width Modulated Control Circuit	\$1.52
UA78L62AWC	3-Terminal Positive	.38
UA78L82AWC	3-Terminal Positive	.38
UA78S4ODC	Universal Switching Regulator Subsystem	2.70
UA78S4OPC	Universal Switching Regulator Subsystem	2.41

## SPECIAL FUNCTIONS

Device	Description	Price
UA2240DC	Programmable Timer/Counter	\$1.72
UA2240PC	Programmable Timer/Counter	\$1.72
UA3086PC	General Purpose Transistor Array	1.21
UA555TC	Single Timing Circuit	.44
UA556PC	Dual Timing Circuit	.37
		.67

## REGULATORS

Device	Description	Price
UA317KC	3-Terminal Positive Adjustable	\$2.69
UA317UC	3-Terminal Positive Adjustable	1.21
UA431AWC	Adjustable Precision Shunt	.53
UA494DC	Pulse Width Modulated Control Circuit	2.28

## OPERATIONAL AMPLIFIERS

Device	Description	Price
UA324PC	Quad Op Amp	.71
UA4136PC	Quad Op Amp	1.07
UA741TC	Frequency Compensated Power Op Amp	.36
UA759UIC	Single BIFET	1.48
UAF771TC	Dual BIFET	.79
UAF772TC	Dual BIFET	1.07

## TELECOMMUNICATIONS

Device	Description	Price
UA3680DC	Telephone Relay Driver	\$3.12
UA5156DC	A-Law Codec	\$23.55

## OPERATIONAL AMPLIFIERS

Device	Description	Price
UA1458HC	Dual Internally Compensated	.99
UA1458TC	Dual Internally Compensated	.37
A301AHC	General Purpose	1.13
301ATC	General Purpose	.75
UA308TC	Super Beta	.43

## DATA ACQUISITIONS

Device	Description	Price
UA565JJC	Digital to Analog Converter	35.00
UA571JJC	Analog to Digital Converter	39.84
UA9708PC	6-Channel 8-Bit up compatible A/D Converter	2.82

## INTERFACE

Device	Description	Price
UA1488PC	Quad Line Driver	1.23
75451BTC	Dual Peripheral Drivers	.64
75452BTC	Dual Peripheral Drivers	.64
75453BTC	Dual Peripheral Drivers	.64
9636ATC	Slew Rate Line Driver	1.88

PRICES PLUS SALES TAX  
IF APPLICABLE

## INTERFACE

Device	Description	Price
9637ATC	Dual Differential Line Receiver	1.88
9667PC	High Current Voltage, Darlingon Driver	1.07
9668PC	High Current Voltage, Darlingon Driver	1.07

## PRICES PLUS POSTAGE & PACKAGING

Prices shown are for minimum quantities of 100+ each device. Larger quantities: prices on application. All prices correct at publication date.

PRODUCTS MANUFACTURED BY

**FAIRCHILD**

A Schlumberger Company

ONE OF THE WORLDS LEADING  
SEMICONDUCTOR MANUFACTURERS

# DX SESSIONS

## — the fast way to find out what's happening

The international shortwave broadcasting scene is constantly changing. The best way to keep track of things is by tuning into the DX information sessions broadcast by the stations themselves.

Arthur Cushen

THE SHORTWAVE STATIONS have realised that they can publicise their own schedule changes and give information about new stations, frequencies and transmission information by incorporating this material in a regular DX session. These are now standard features of the programme schedule of almost all international broadcasters.

It was Australia that pioneered the DX session, with a programme first scheduled in July 1946. Unfortunately after a run of 31 years, the programme was withdrawn at the end of October 1977. The original concept was put together by three South Australian listeners, Ern Suffock, Jim Paris and Rex Gillett. Ern Suffock wrote the script and it was sent to Melbourne for broadcast.

Later Graham Hutchins commenced a regular session on Radio Australia, known as "Australian DXers Calling". In subsequent years the session was presented under various programme titles and became a part of "Club Forum" with Keith Glover till December 1980, then "Spectrum" with Dick Speckman and now is part of "Talkback" hosted by Barry Seeb-er.

At the same time, DX tips have been broadcast for many years in the Japanese Language Service of Radio Australia. During the period of the early 1950s, information for the shortwave listener appeared in print with Rex Gillett contributing a feature in "Radio Call" a programme magazine published in Adelaide, and Graham Hutchins in "Listener In" in Melbourne, but both these publications folded many years ago.

After the deaths of Ern Suffock and Jim Paris, DX information was centred in Melbourne. Contributions are now made to the programme by the Australian Radio DX Club.



Miss Yuka Nukina and Mr Hiroshi Shloguchi, comperes of Radio Japan's regular session 'DX Corner'.

In New Zealand the first regular DX programme went on the air in January, 1960 as part of Cleve Costello's "This Radio Age", a magazine feature of radio information. During the 1950s this writer contributed from time to time items of interest to radio listeners. "Arthur Cushen's DX World" became a 15 minute feature on Radio New Zealand and was carried not only on the shortwave service, but also on the national mediumwave programme.

During 1975 Radio New Zealand was off the air for some weeks but due to protest from listeners it returned with an expanded DX programme broadcast every two

weeks. In 1980 "The DX World" became part of a special feature compered by Tony King, which included a segment in Japanese and this fortnightly session ended in May 1982 when the Government withdrew the subsidy to Radio New Zealand.

Today DX information in New Zealand is available on Radio Rhema on Friday at 1015 UTC and on 4XD at 0845 UTC on Sunday, on mediumwave. In the field of print material, in the 1940s the "Lamp-house Annual" provided a list of the main stations in the world, while a monthly publication, "Radiogram" gave listeners the latest news on shortwave broadcasting.

From July 1952 the writer has been contributing a column in the "NZ Listener" which has now been printed continuously for 33 years.

### Longest Running Session

"Sweden Calling DXers" is the session with the longest continuous broadcasting history, commencing in February 1948. Arne Skoog was the founder of the programme and broadcast the session weekly until his retirement in 1981. The new compere is George Wood.

Radio Nederland has been voted the most popular DX session, which had its beginnings in the 1950s with Harry Van Gelder and DX Juke Box. During this time there were promotions of the hobby including special publications, DX courses and the like. Fritz Greveling and Dick Speekman continued the programme after Harry Van Gelder's retirement.

In 1977 Jonathan Marks the present compere, took over the session. Retitled "Media Network" in October 1980, it now



Adrian Peterson, compere of the program 'Radio Monitors International' broadcast by Sri Lanka Broadcasting Corporation.

incorporates a wide variety of information moving into computers, video material and other modern electronics. The DX contributions still remain a mainstay in the programme with news from the Pacific, Africa, Denmark and South Asia each Thursday, in that order. Other features include items on clandestine broadcasts, new receivers and station news.

The BBC has also had continuous interest in the shortwave listener, although its programme could not be classed as a DX session but mainly news on BBC activities and help to listeners with technical questions. The late 1960s saw the introduction

of BBC World Radio Club, with Henry Hatch and Reg Kennedy. After the Club was disbanded in 1980, it was replaced with "Waveguide", a weekly feature on BBC frequencies and reception conditions.

Radio Canada International has also a long interest in its shortwave audience. Radio Canada Shortwave Club was established in the 60s, with monthly technical bulletins featuring DX information and a weekly programme on shortwave with Ian McFarland. This programme ended on 1 November 1975 but later was revived with Ian McFarland and the "Shortwave Listener's Digest" — now a regular transmission each week from Montreal.

HCJB Quito Ecuador diversifies wider than the station's normal straight gospel programme, and in 1962 started "DX Party Line". After its initial introduction this was compere by Clayton Howard for 22 years, until last year when the new host John Beck became promoter of the feature. It has a regular DX contribution from the South Pacific in the third Monday of each month's transmission and recently returned to a three times a week programme.

Australia's nearest neighbour with a DX session is KTWR Agana Guam, with its "DX Listeners' Log" broadcast weekly. It is part of the schedule of a relatively new station, opened in September 1977 and includes contributions from many listeners including a monthly feature from the South Pacific Association of Radio Clubs. This is compere by Keith Barton of Adelaide.

Radio Budapest Shortwave Club is one of the best known from Eastern Europe. This club issues a monthly magazine with technical articles, information on problems, some of them being solved by readers and DX tips from contributors mainly from Europe. RBSWC issues an annual membership certificate and honours its long-standing listeners with life membership by the award of an attractive plaque.

Radio Japan's "DX Corner" has been a feature of the Tokyo programmes for many years and has recently been expanded and given its own slot in the schedule. Broadcasts on Saturday 0915-0930 UTC include DX tips, sunspot information and technical articles.

Swiss Radio International has "Swiss Shortwave Merry-go-Round" on the air every second and fourth Saturday, with presenter Bob Tulman, who has been with the programme for over 20 years. Bob Zinotti also shares the presentation. Both are radio amateurs, so the programme has a more technical touch. It has contributions of DX news from Noel Green of England, features a mystery sound on shortwave and the latest sunspot count and predictions.

"Radio Monitors International" is featured from the Sri Lanka Broadcasting Corporation. The programme is recorded at AWR studios in Poona, India by Adrian Peterson and is carried from the Colombo

station each week. The broadcast is also carried on exchange from Radio Canada and WRNO New Orleans, giving it a much wider audience than South Asia and the Pacific. The 30-minute weekly session has a station profile each week with background. The much-travelled compere of the session is in the position to record many of the world's unique and seldom heard broadcasting stations when involved in his missionary work.

### CURRENTLY AVAILABLE DX SESSIONS

#### Sunday

0200 UTC Radio South Africa 9615 kHz  
 0210 Radio Australia 15240 kHz  
 0620 Radio Moscow 15130 kHz  
 0900 Radio Austria 15270 kHz  
 0900 Adventist World Radio, Portugal 9670 kHz  
 1910 Radio Belgium 15590 kHz

#### Monday

0030 UTC Radio Belgium 9925 kHz  
 0305 Radio Canada 9755 kHz  
 0400 Radio Sofia, Bulgaria 11750 kHz  
 0550 Radio Exterior, Spain 9630 kHz  
 0915 BBC London 11750 kHz  
 0930 HCJB, Quito 6130 kHz  
 1040 (1st and 3rd) India, AIR 17705 kHz

#### Tuesday

0050 UTC Radio Moscow 12010 kHz  
 1115 Radio Sweden 17820 kHz

#### Wednesday

0400 UTC Radio Sofia, Bulgaria 11750 kHz  
 0400 Radio Budapest, Hungary 9832 kHz  
 0700 HCJB, Quito 9745 kHz  
 1915 Radio Belgium 15590 kHz  
 2000 Radio Prague, Czechoslovakia 7345 kHz

#### Thursday

0030 UTC  
 0750  
 1050

#### Friday

0100 UTC Radio Prague, Czechoslovakia 11990 kHz  
 0300 Radio Prague 11990 kHz  
 0550 Radio Nederland 9895 kHz

#### Saturday

0043 UTC KTWR Guam 17790 kHz  
 0400 Radio Budapest, Hungary 9835 kHz  
 0705 Swiss Radio International 9650 kHz  
 0905 Swiss Radio International 15570 kHz  
 0915 Radio Japan 11875 kHz  
 0930 HCJB Quito Ecuador 6130 kHz  
 0958 KTWR Guam 11840 kHz  
 1530 KTWR Guam 9535 kHz  
 2135 Radio Canada 15325 kHz

*This item was contributed by Arthur Cushen, 212 Earn St., Invercargill New Zealand, who would be pleased to supply additional information on medium and shortwave listening. All items quoted are UTC (GMT) 10 hours behind Sydney time, all frequencies are in kilohertz (kHz). In areas observing daylight time, add a further hour.*

6 X 3 = 18¢
8 X 3 = 24¢
14 X 3 = 42¢
16 X 3 = 48¢
18 X 3 = 54¢
20 X 3 = 60¢
22 X 3 = 66¢
24 X 3 = 72¢
28 X 3 = 84¢
40 X 3 = 1-20¢
64 X 3 = 1-92¢

**OK, Now you've learned  
our 3 times tables\***

**Call us for the best deal  
in Australia!**

**for  
Gold plated, machined contact  
IC sockets** \* each, 100 pcs. min. + tax

Manufactured by SIEFERT GmbH - West Germany

Promark Electronics

Sydney 439 6477	Melbourne 878 1455	Brisbane (008) 22 6226	Adelaide (008) 22 6226	Perth 328 9755
--------------------	-----------------------	---------------------------	---------------------------	-------------------



# Subscribe to Electronics Today now, and receive a 20-watt soldering iron worth \$9.95

## ABSOLUTELY FREE!

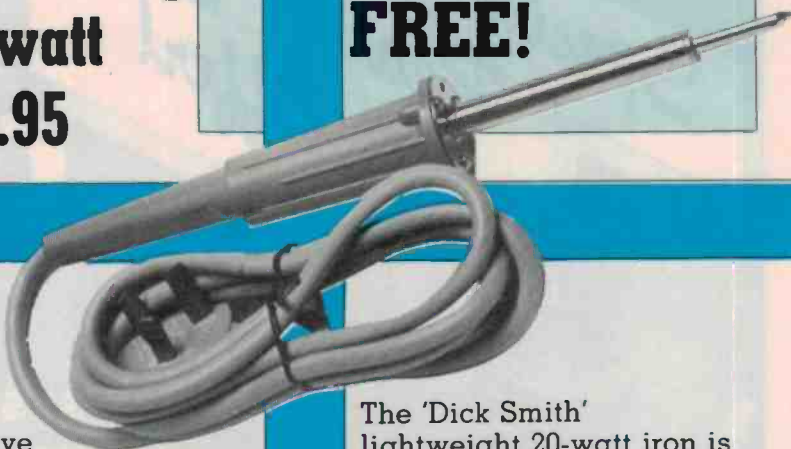

Right now is certainly the best time to take out a 12-month subscription to Electronics Today. You'll not only be ensuring that you receive each copy regularly each month, delivered direct to you, but you'll also receive a bonus gift: a free 'Dick Smith' soldering iron suitable for the electronics hobbyist, home handyman or technician. But don't delay — this offer is limited.

The 'Dick Smith' lightweight 20-watt iron is ideal for most general soldering work. It features interchangeable screw-in tips, a two-metre mains cord with moulded-on plug for safety and durability, and is fully S.E.C. tested and approved. It comes fitted with a plated conical tip, suitable for most general soldering. Normally this quality iron sells for \$9.95 — but currently we're offering it to you FREE with each 12-month subscription to Electronics Today!

### Australia's dynamic electronics monthly!

Electronics Today is your key to the exciting world of modern electronics — whether you're a professional, an enthusiast or an interested consumer. Electronics Today provides you with news and analysis of the latest developments, authoritative test reports and reviews of new equipment, down-to-earth information on electronics in theory and practice, and well-engineered construction projects.

Electronics Today is also written right here in Australia, so you know that it really does cover the local electronics scene.

## Electronics Today Subscription Offer

### YES!

Please send me one full year (12 issues) of Electronics Today, delivered to my home, PLUS my free Dick Smith soldering iron at the special offer price of just **\$27.00**

**FREE  
SOLDERING  
IRON**

NAME: ..... JOB/TITLE: .....

ADDRESS: .....

POSTCODE: ..... ORGANISATION: .....

Please tick box to indicate method of payment:

Cheque\*/Money Order\*  American Express  Bankcard  Mastercard

\*Please make cheques and money orders payable to the Federal Publishing Company Pty Ltd. Credit Card No.

Card Expiry Date: ..... Signature: .....

(Unsigned orders cannot be accepted)

Allow 4-6 weeks for delivery of first issue and soldering iron.

Just  
**\$27.00**

*That's a \$3 saving on our regular 12-month subscription rate!*

## So don't delay — subscribe now in this issue!



# GET YOUR COMPUTER TALKING!

**ONLY \$75!** ready-built and operating board. Just attach your own speaker and a connector to suit your computer and it's ready to rave!

The **CHATTERBOX** just hooks into your computer's parallel or Centronics port and is programmed quite simply as explained in Tom Moffat's article in the January issue of ETI. Never before has true voice synthesis been offered so cheaply. Here's an unbeatable opportunity to get into this fascinating facet of computing. And the best part is — you don't have the potential hassles and anxiety of building it up — **the project arrives ready-built!**

All that's left for you is to add a speaker and connector to suit your computer's port (as these vary from model to model, we have to leave it to you). You might need to arrange a suitable power supply (a plugpack's great!) unless you can tap into your computer's supply rails.

And for Commodore owners a special interface card to drive the Chatterbox is available for \$25!

**The ETI-677 CHATTERBOX Voice Synthesiser Project** was developed by Tom Moffat, well-known to ETI readers, who is Development Engineer for Flexible Systems, makers of the Tasman Turtle and Turtle Tot educational robots, which they export to Europe and the US. The project was designed around the Votrax SC-01 voice synthesiser chip. But that presented a problem — there was no Australian distributor for it when the project was first mooted. After some considerable footwork on the part of Flexible Systems, they managed to obtain an agreement with the Federal Screw Works (true!), manufacturers of the SC-01 chip. With supply assured the project was ready to roll. But in the past, voice synthesiser projects proved not terribly popular. They were relatively expensive; some gave limited realism, others had limited vocabulary. Perhaps the concept was 'too early'. So, to 'sweeten the deal' and to encourage the inveterate 'hacker' into the ground floor of a computing field that is rapidly burgeoning, **Electronics Today** and **Flexible Systems** devised this special offer, **exclusive to ETI readers**. Flexible Systems would normally sell this product for \$90, but for **the next three months** they will offer it to readers for the fabulous price of **just \$75!**

**Sweet enough?**

**Don't delay**

**— send the coupon today!**

Offer extended until last post April 30 1985.

## FEDERAL MARKETING ORDER FORM

*Yes! I don't want to miss this opportunity! Please rush me*  
 ..... *ETI-677 Chatterbox Voice Synthesisers at the great*  
 ..... *price of \$75,*  
 ..... *Special Commodore Interfaces at \$25,*  
 ..... *plus \$2.50 post and handling.*

Name .....

Address .....

..... Postcode .....

Signature .....  
 (Unsigned orders cannot be accepted.)

American Express  Bankcard  Cheque\*

\* Please make cheques payable to the Federal Publishing Company Pty. Ltd.

Credit Card No: ..... Card Expiry Date: .....

Send completed coupon to:  
 Federal Marketing, PO Box 227, Waterloo NSW 2017.

# Zenith Data Systems'

# "CHOICE"

# vs. Their "ULTIMATUM"

Green or Amber  
Monochromatic Display Monitor Option

Zenith Data Systems presents a COLOR CHOICE in monochromatic monitor displays at a price designed to save you money!

Choose the ZVM 122 Amber or the ZVM 123 Green Phosphor display for crisp character definition and easy-on-the-eyes viewing.

- Both the ZVM 122 and ZVM 123 Offer:
- Popular System Compatibility
  - Front Access Control Panel
  - Constant Intensity 12" Diagonal Display
  - 40/80 Character Selection Switch
  - Contemporary, Lightweight Style



**ZENITH data systems**  
THE QUALITY LEARN TO BELIEVE THE NAME LEARN TO.

#### COMPATIBILITY CHART

Zenith Z-100 Desktop  
Apple II and III  
IBM PC\*  
Commodore Vic 20\*  
Compaq\*  
Texas Instruments 99/4\*  
Atari 800\*  
Atari 1200\*

\* optional cable required

For further information contact your local Zenith dealer, or Warburton Franki  
Distributed exclusively in Australia by:



## Warburton Franki

A DIVISION OF THE ANI CORPORATION LTD (INCORPORATED IN N.S.W.)

- ADELAIDE (08) 356-7333 • BRISBANE (07) 277-0222
- HOBART (002) 28-0321 • MELBOURNE (03) 795-9011
- PERTH (09) 277-7000 • SYDNEY (02) 648-1711
- AUCKLAND N.Z. (09) 50-4458 • WELLINGTON N.Z. (04) 69-3016

## "Changing to QED 79 Strand Speaker Cable is the cheapest upgrade you will ever make."

Hi Fi Answers,  
November 1982



QED 79 Strand Speaker Cable avoids signal losses, and offers an AUDIBLE Improvement over standard cables, with an Increase in clarity across the full frequency range.

Installing QED 79 Strand Speaker Cable can give you improvements similar to changing a major component, but at a fraction of the cost.

At \$3.25 per metre it could be the cheapest improvement you have ever made.

For further information and trade enquiries, contact:

**LEISURE IMPORTS, P.O. Box 247, Artarmon  
NSW 2064. Phone (02) 438-4166.**

## PROFESSIONAL QUALITY ELECTRONIC COMPONENTS

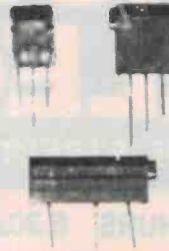

**COPAL**

CT-6/9/20 series of sealed cermet trimmers — single and multiturn. 10% tol. 0.5W 1% C.R.V.



**micro-parts electronic Ltd.**

"NIF" No Insertion Force IC Socket: Low profile, small body size. Available in 24, 28, 40 and 48 pin.

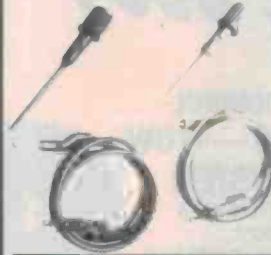

**Hirschmann**

PMK-409N Test Lead Pack with 2 x PRUF 2 and 2 x ML100



**micro-parts electronic Ltd.**

Machine Pin 4 Leaf Gold Contact low profile IC Sockets. Available with solder pin or 3 wire wrap 6-40 pin.

**OKW**



Plastic Cases. Two part, high-impact polystyrene cases suitable for accommodating instrumentation, PCB's and other electronic components.



## MAYER KRIEG & CO.

248 ANGAS ST., ADELAIDE, S.A. 5000.

For further information and data sheets contact your local distributor.

NSW: Mayer Krieg (02) 638 4055;  
M. Ruffy (02) 476 4066.

NEWCASTLE: DGE Systems (049) 69 1625.

QLD: E.C.Q. Electronics (07) 376 5677;

Fred Hoe (07) 277 4311.

SA: Anelco Electronics (08) 294 2600.

VIC: Mayer Krieg (03) 579 5722.

WA: Pro-Spec Distributors

(09) 362 5011.

NZ: Chonnelmaster (9) 59 9003.



# ACTIVE ELECTRONICS

289 LATROBE STREET, MELBOURNE 3000 PH. 602 3499

8.30am-5.30pm MON-THURS 8.30am-8.30pm FRIDAYS 9am-12noon SATURDAY

## More Scope Now at Active!

\$19.25

**NEW**  
NON TEMP CONTROL  
PRODUCTION QUALITY  
20W IRON

Model PH20  
240V Iron 370°C

- COMFORTABLE AIR COOLED FINGER GRIP
- CMOS PROTECTION - FULLY EARTHED
- LONG LIFE IRON PLATED TIP RANGE

Model STS2  
Safety Stand & Sponge

\$17.95

MANUAL TEMP. CONTROL  
ADJUSTABLE 10W—70W  
SOLDERING SYSTEM

- YOUR FINGER ADJUSTS WATTAGE & TEMP. 200°—500°C
- MULTI PURPOSE ADJUSTABLE SERVICE IRON
- FAST 5 SEC HEAT FOR MAINTENANCE & REPAIR WORK

\$34.75

Model MS  
4V Iron

Model PSU  
240V-4V Power Supply Unit

\$29.60

\$13.20

BUILT LIKE PLIERS - FINE LIKE  
TWEEZERS

- THIN PROFILE 25mm RIGID JAWS
- SERRATED JAWS
- CUSHION PVC GRIP

Model 378

FLUSH TYPE PCB SIDE CUTTERS  
RADICAL SCISSOR ACTION

- SAFETY 'OFFCUT' CATCHER OPTION
- SMALL NARROW BLADES FOR TIGHT CORNERS
- SCISSOR ACTION REDUCES CUTTING EFFORT

Model 175-1

\$11.80

**NEW** DISPENSER KEEPS  
FINGERS COOL

- POSITIONS BRAID MORE ACCURATELY
- REDUCED RISK OF BURNT FINGERS
- DISPENSER WINDS BACK SURPLUS BRAID

- 2 METRE PACK - HOLDS 30% MORE

\$2.75

SELF CLEAN TIP - METAL BODY

- CRUSH PROOF METAL BODY
- TIP SELF CLEANS EVERY CYCLE
- NEOPRENE "O" RING FOR ACCURATE SEAL

Model SR  
Solder Remover

\$14.95

POSTAGE RATES

\$1-\$9.99	\$1.50	\$100-\$199	\$5.00
\$10-\$24.99	\$2.00	\$200-\$499	7.50
\$25-\$49.99	\$3.00	\$500 plus	\$10.00
\$50-\$99.99	\$3.50		

MAIL ORDER  
HOT LINE

(03) 671312



MAIL ORDER

MAIL ORDER

MAIL ORDER

MAIL ORDER

MAIL ORDER

MAIL ORDER

MAIL ORDER

MAIL ORDER

MAIL ORDER

MAIL ORDER

MAIL ORDER

# Spy stations create intriguing listening



OVER THE past few years shortwave listeners have become aware of an unusual type of broadcaster who is heard transmitting coded messages.

So called number stations are heard in German, Spanish, English, Korean and Czech on various out of band channels on shortwave. The first was the German number station which broadcasts from East Germany and carrying coded messages for agents in Western Europe. Spanish broadcasts soon followed originating from Cuba, presumably for agents in Latin America. Korean, from North Korea to agents in South Korea and broadcasts in Czech to Western Europe have also been heard. The English message service is a relative newcomer in the field of undercover information.

According to Bob Grove in his publication *Shortwave Directory*

many countries of the world utilize the shortwave spectrum for sending coded broadcasts to resident agents. These are most often heard as four or five digit number groups in a female voice in the native language of the intended recipient. The voice has a mechanical rhythm to it due to the method in which it is sent: a keyboard selects the recorded voice one character at a time.

The format is similar for most countries: a callup ("attention") is followed by a three-digit address (agent's identification) then a group count (number of groups in the message to follow). After the text is broadcast, "finale" or "end of message" may be heard.

Many frequencies are paired, simulcasting the message to assure reception in case of interference or propagational problems. Often the same message is repeated on another frequency immediately after the first transmission. Messages identical in content are sometimes sent months later, indicating possible phantom traffic for practice or diversionary dis-information.

Most schedules are on quarter hours, with on the hour being the commonest. While full carrier AM is still heard, there is a gradual trend towards reduced-carrier upper sideband. Occasional Morse code groups alternate with the voice broadcasts.

A variant on the numbers sta-

tions is the phonetic broadcaster and recent reports suggest the origin of these transmissions to be the Israeli "Mossad" intelligence organisation.

Speculation on the content of numbers messages is varied, but they probably contain routine itinerary information for field agents behind foreign borders. They are decoded using a one-time pad which cannot be broken by computer analysis.

A recent comprehensive list of numbers stations transmissions is available from Grove Enterprises Inc, Brasstown NC 28902, USA.

— Arthur Cushen

## 13 MHz band to be created

THE RECENT World Administrative Radio Conference was faced with the problem of too many stations for too few frequencies, so an expansion of the shortwave bands was inevitable.

All the bands are being expanded from 6 to 21 MHz, while the 25 MHz band is to suffer a reduction. A new band being created is the 13 MHz band between 13.6 MHz and 13.8 MHz.

Recent surveys show that there are 163 countries operating on shortwave with a total of about 1500 shortwave transmitters in operation. In the international broadcasting field there are 100 countries operating an external service, and it is presumed they operate about 16

hours a day which means that an average of 1000 transmitters are in operation at any given moment of the day, according to Jim Vastenhound of Radio Nederland.

The expansion of the shortwave bands is to take effect in 1989, but already the new 13 MHz band is being used by eight countries. Radio Moscow has shown the greatest interest in this band and has been received on seven frequencies, while other countries noted are Pakistan, South Korea, Iraq, Holland, Israel, Iran and Iceland.

Monitoring observations show the following frequencies are being used in this new band:

- |                                            |                                                                   |
|--------------------------------------------|-------------------------------------------------------------------|
| 13600 kHz USSR, Radio Moscow;              | 13670 kHz South Korea, Radio Korea, Seoul;                        |
| 13605 kHz Radio Pakistan, Islamabad;       | 13670 kHz Radio Nederland, Flevoland;                             |
| 13625 kHz USSR, Radio Moscow;              | 13680 kHz USSR Radio Moscow;                                      |
| 13635 kHz USSR, Radio Moscow;              | 13700 kHz Iraq, Radio Baghdad;                                    |
| 13645 kHz USSR, Radio Moscow;              | 13720 kHz Israel, Israel Broadcasting Authority, Tel Aviv;        |
| 13650 kHz USSR, Radio Moscow;              | 13745 kHz Iran, Radio Iran, Teheran;                              |
| 13660 kHz USSR, Radio Moscow;              | 13797 kHz Iceland, Iceland State Broadcasting Service, Reikjavik. |
| 13665 kHz South Korea, Radio Korea, Seoul; |                                                                   |

— Arthur Cushen

## Synchronous receiver reduces fading

RELEASE OF the ICF-2001D, a multi-band PLL synthesized tuning radio covering LW, MW, SW, FM, and Air bands, has been announced by Sony.

It features a synchronous detecting system, to substantially reduce fading and beat interference; wide/narrow selectivity settings; 32 memory presets; a

four programme timer; selection for upper or lower sidebands; and 10 key direct access tuning or analogue tuning in 100 Hz steps.

Its specifications are a frequency range of AM 150 kHz-30 MHz; FM 76-108 MHz; Air 116-136 MHz; dimensions of 288 mm (w) x 159 mm (h) x

52 mm (d) and (weight) 1.7 kg (incl. batteries).

The new model retails at \$499 (rrp) from February.



For further information contact Sony (Australia) Pty Ltd. (02)887-6666.

## ABC to broadcast on HF band

A NEW high-frequency (short-wave) radio service to be introduced this year means that for the first time ABC radio will be heard throughout the Northern Territory.

The Minister for Communications, Mr Michael Duffy, has announced that three high-powered (50 000 watt) transmitting stations would be used to provide the new service.

They would be sited at Alice Springs, Tennant Creek and Katherine and each would have a range of approximately 240 km in all directions.

"Programs for the service will originate in the Darwin and Alice Springs studios of the ABC," Mr Duffy said. "For most of the time they will be the same as programs broadcast on the present medium-frequency stations — 8DR (Darwin), 8AL (Alice Springs), 8G0 (Nhulunbuy), 8JB (Jabiru), 8KN (Katherine) and 8TC (Tennant Creek).

"The ABC does have plans however to include segments of special interest to remote areas."

The Minister said the cost of the new service was estimated at \$3.8 million.

He advised people thinking of buying new radio receivers to look for those providing short-wave reception on the following bands:

120 metres (2.3 to 2.5 MHz), 90 metres (3.2 to 3.4 MHz), 60 metres (4.8 to 5.0 MHz), 49 metres (6.0 to 6.2 MHz), 31 metres (9.5 to 9.8 MHz).

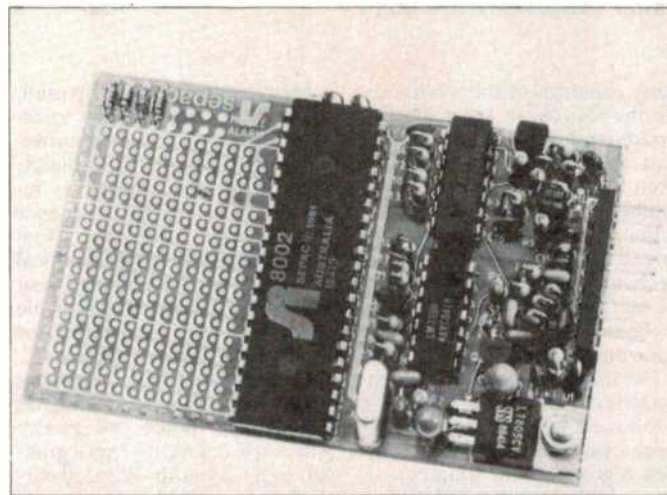

## Printed selcal circuit board level

A NEW pc board level selcal module has been added to Sepac's increasing range of selective calling products.

The S370 pc board is small enough to fit internally to most two way radios thus allowing, via a single switch operation, selective calling (selcal) on either a fleet or individual address basis.

Based on Sepac's reliable SI8002 microprocessor signalling IC, this pc board allows normal quiet operation of the

mobile, or base station, within the fleet until decode of an individually addressed selcal.

Benefits of this 'state of the art' pc board include, on return of the operator to an unattended mobile, a visual indication of the decode displayed and an audible indication to the caller that their selcal has been received, decoded and stored.

Selection of all five tones of the receive and transmit codes, plus selection of tone periods,

lead in delay, tone format and other features are achieved by simple solder bridging of the code matrix, eliminating the necessity to cut tracks and add components as in other inexpensive selcal pc boards, thus reducing error, fitting time and eliminating time consuming circuit diagram examination.

All enquiries to Sepac Industries (Australia) Pty Ltd, 134 Beach St, Frankston, Vic 3199. (03)781-3144.

## Amateur radio award

THE GEELONG Radio and Electronic Society is introducing a new award to be named the "City by the Bay" award after the slogan of the city of Geelong.

The award will be issued to an entering club station depending

on how many points the station can accrue for contact with club station VK3ANR, contact with club members (mobile) and contact with fixed station club members. Interested clubs must keep and submit a record in log form and have their contacts

confirmed.

For further information about the Geelong Radio and Electronic Society or the "City of the Bay" award, contact Roy Whit-side, Awards Manager, 11 Carinya Ave, Newcomb, Vic 3219.

## 2 kilowatt dummy load

GFS ELECTRONIC Imports recently announced the availability of a 2 kw oil cooled 50 ohm dummy load from MFJ Enterprises. Known as the MFJ-250 the load is rated at 2 kW PEP and 1 kW CW for 10 minutes. A full derating curve is supplied with each unit.

The MFJ-250 exhibits a usable VSWR up to 400 MHz. For example, VSWR is less than 1.2:1 over 0 to 30 MHz, less than 1.5:1 over 30 to 300 MHz and

less than 2.1, 300 to 400 MHz. Only high quality industrial transformer oil is supplied with the MFJ-250. Power input to the load is via an SO-239 coaxial connector mounted on top. A safety vent is also incorporated in the lid. Price of the MFJ-250 is \$71 plus \$12 freight.

For further information contact GFS Electronic Imports, 17 McKeon Rd, Mitcham 3132. (03)873-3777.



## New 720 channel transceiver

A NEW 720 channel synthesised hand-held airband transceiver was recently released by GFS Electronic Imports. Manufactured in Japan and known as the ATC-720X it is approved for use within Australia by the Department of Communications.

Facilities featured on the ATC-720X include 25 kHz channel steps using thumbwheel

selectors over a receive-only range of 108.000 to 117.950 with the transceiver range extending from 118.000 to 136.000. This constitutes 720 channels for communication and 200 channels for monitoring VORs. Three memories are provided which are user selectable. The memories as well as the dial frequency may be scanned by

the use of inbuilt scanning circuitry. Transmitter power is selectable from 200 milliwatts to 1 watt.

The ATC-720X is supplied complete with a flexible rubber duck antenna. It accepts six AA Alkaline batteries or an optional nicad battery pack as a power source.

Size is 192 mm x 66 mm x

40 mm (62 mm at top) and weight is 400 grams not including the batteries. Its case is made from high impact resistant ABS plastic.

For further information contact the Australian distributors GFS Electronic Imports, 17 McKeon Road, Mitcham, Vic. (03)873-3777.

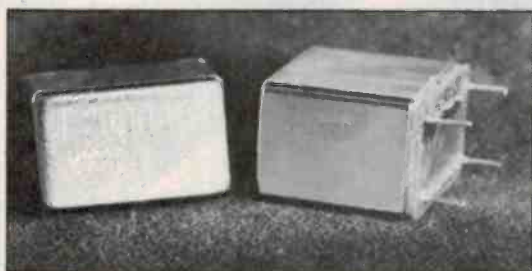

### Odd Clocks

Computer Clocks to order  
Frequency range 50Hz to 50MHz  
Standard or custom pin out  
48 hour service on small quantity orders 1-10 units

### Micro/Processor Computer Crystals

Full range ex stock (subject to prior sale)  
48 hour service.

### Custom Crystals

Frequency range 1.4 MHz to 110MHz  
phone/write/telex for price and delivery.

### BRIGHT STAR CRYSTALS PTY LTD

35 Eileen Road, Clayton, Vic. 3168.  
Telephone: (03) 546 5076. Telex: 36004.

## Building your own speakers? Or updating your old?

Now available in Australia, are the famous DYNAUDIO loudspeaker drivers from Denmark. World leading loudspeaker brands use the magnificent drivers from DYNAUDIO.

All drivers are protected by US patent 4 048 713. They feature hexagonal wires for voicecoils, magnetic oil in voicecoils for high power handling, woofers with symmetrical drive, voicecoil sizes up to 4". Crossovers use only the best components available. We stock woofers, dome midranges and tweeters as well as matching crossover networks.



Sole Australian Distributor:  
**SCAN AUDIO PTY. LTD.**  
P.O. Box 242, Hawthorn. 3122. (03) 819 5352

# DIGITAL MULTIMETERS

FROM **BENELEC**

## THREE MODELS TO CHOOSE FROM —

All 3½-digit LCD Meters Featuring 0.5% (dc) Basic Accuracy 'Professional' Instruments at a Hobbyist Price!

BENELEC PTY LTD had such a resounding success with a previous offer made through Electronics Today that they approached us about launching two new multimeters in their Univolt range in the same way.

Univolt is no new brand to the Australian market. BENELEC has been distributing Univolt multimeters here for the past five years. The instruments are designed, developed, manufactured and marketed under the company name — no 'badge' engineering here. These meters are imported exclusively by BENELEC PTY LTD who warranty and service them here. They've been in the electronics business for over eight years and believe in handling quality products.

Here's an incredible opportunity to get the sort of multimeter to suit your needs at virtually unbeatable prices!

Univolt's continuing design and development program has brought two new models to the marketplace and this is the first time the DT-1000 and PD-1800 models have been offered here. The DT-860 was first offered two years ago and, as a sort of 'anniversary deal', Benelec are again offering the DT-860, but this time at a lower price!

## DON'T MISS OUT — ORDER NOW!

Send completed coupon to:  
Federal Marketing, BENELEC/ETI Multimeter Offer,  
PO Box 227, Waterloo NSW 2017.

I don't want to miss out on this special offer.  
Please rush me the following:

..... DT-1000 Multimeter(s) at \$ .....  
..... PD-1800 Multimeter(s) at \$ .....  
..... DT-860K Multimeter(s) at \$ .....

Sales Tax No: ..... (if applicable)

Please add \$2.50 post and handling per unit ordered.

TOTAL \$ .....

(allow up to four weeks for delivery)

Name .....

Address .....

Postcode .....

Signature .....

American Express  Bankcard  Cheque\*

\* Please make cheques payable to the Federal Publishing Company Pty. Ltd.

Credit Card No: .....

Expiry Date: .....

OFFER CLOSSES LAST MAIL SUNDAY 31 MARCH



### DT-860K AUTORANGING DIGITAL MULTIMETER

This popular LCD readout digital multimeter features 25 measurement ranges with autoranging on dc and ac volts and resistance. It incorporates a transistor gain measurement function as well as diode and continuity check functions. It comes complete with a carry case, 'safety' probes and transistor  $h_{FE}$  clip-probe.

All for only: \$70 (tax exempt); \$90 tax paid. 3½-digit LCD readout (1999 max.); dc voltage ranges — 200 mV, 2, 20, 200, 1000, 0.5% basic accuracy; ac voltage ranges — 2, 20, 200, 750 V, basic accuracy 0.75%; dc and ac current ranges — 2, 200 mA, 10 A, basic 1% dc and 1.2% ac accuracy; resistance ranges — 200, 2k, 20k, 200k, 2M, 20M, 0.5% basic accuracy; transistor  $h_{FE}$  (NPN or PNP) to 1999 with  $V_{CE}$  of 1.2 V,  $I_B$  of 1  $\mu$ A; diode check reads forward voltage drop; continuity check sounds buzzer under 20 ohms; overload protected; power supply — 2 x 1.5 V (AA) cells (inc.).

### NEW! UNIVOLT DT-1000K DIGITAL MULTIMETER

Univolt's top-of-the line handheld LCD multimeter. It features 30 measurement ranges, including dc volts, ac volts, dc and ac current, transistor  $h_{FE}$  (gain) plus diode check and audible continuity check (beeper). Range selection is via the single large rotary switch. The case features a pop-up stand and the whole unit comes with carrying case, probes and  $h_{FE}$  clip-probe for just: \$73.40 (tax exempt); \$95 tax paid. 3½-digit LCD readout (1999 max); dc voltage ranges — 200 mV, 2, 20, 200, 1000 V, 0.5% basic accuracy; ac voltage ranges — as for dc but 750 V on top range, basic 1% accuracy; dc and ac current ranges — 200  $\mu$ A, 2, 20, 200 mA, 10 A, 1% basic accuracy on dc, 1.2% on ac; input impedance — 10M; resistance ranges — 200, 2k, 20k, 200k, 2M, 20M, 1% basic accuracy; transistor  $h_{FE}$  (NPN or PNP) to 1000 with  $V_{CE}$  of 2.0 V,  $I_B$  of 10  $\mu$ A; diode check reads forward voltage drop; continuity check sounds buzzer under 20 ohms; overload protected; power supply — 9 V No. 216 battery (inc.).

### NEW! UNIVOLT PD-1800 DIGITAL PROBE TESTER

Wow! — a tiny digital volt-ohm-continuity probe with the 3½-digit LCD readout built-in! Great for the toolkit, great for the beach! It features autoranging on volts and ohms as well as autopolarity indication. A beeper sounds in the continuity test mode. There are four dc and ac voltage ranges and four resistance ranges. It measures a tiny 163 mm long, 28 mm high and 19 mm deep! How much? \$50 (tax exempt); \$65 tax paid.

3½-digit LCD readout (1999 max.); ac and dc voltage ranges — 2, 20, 200, 500 V, basic accuracy 0.5% dc, 1% ac; resistance ranges — 2k, 20k, 200k, 2M, basic accuracy 0.7% (in-circuit test capability — uses 0.3 V on ohms range); input impedance — above 10M; power supply — 2 x 1.5 V (LR-44) cells (inc.).

This offer is exclusive to readers of Electronics Today and products can only be obtained by sending in the attached coupon (or a clear photostat or hand-copied facsimile). **90 DAY WARRANTY ON ALL METERS** (from date of despatch).



## ETI-280 Low battery indicator

This is a reasonably simple project, designed for the most part with of-the-shelf components. You should have little trouble getting hold of them. In Melbourne the Rod Irving organization will be selling it in kit form for \$7.95. In Perth, Altronics will do you a deal for \$7.50.

## ETI-182 Digital luxmeter

This project can measure light levels from 1 to 20k lux. The only problem you are likely to have is with the photodiode, a BPW21 distributed by Promark in Sydney. Kits from Rod Irving \$75.

## ETI-1405 Stereo enhancer

The biggest project of the month. It's designed to add a little extra oompa to your sound system. Cost of a Rod Irving kit is \$114.95. The LED array and most of the

parts will be available from Jaycar in Sydney. In Perth Altronics is selling the kit for \$69.50.

## Artwork

Making your own pc boards? Full-size positive or negative film is available for the prices listed below. Send requests, with payment, to: *ETI-xxx Artwork, ETI magazine, PO Box 227, Waterloo, NSW 2017*. Make sure you specify positives or negatives, according to the process you use. Make cheques or money orders payable to 'ETI Artwork Sales'. Here are the prices for this month's projects.

ETI-182 pc board .....	\$2.10
front panel .....	\$3.00
ETI-1405 pc board (a).....	\$3.90
(b) .....	\$3.50
front panel .....	\$6.15
rear panel .....	\$2.70
ETI-280 pc board .....	\$1

## MINI MART

### COMPUTERS

FOR SALE: MICROBEE 32K PC. Wordbee, Network MOW, games \$450. Sony U-matics, 3800 P portapack, p/supply, batteries \$500. 1210 player \$250. M. Hartman . (02)630-6313.

WANTED: SYSTEM 80 Technical manual. David Gerard, 17 Simper St, Wembley 6014. (09)387-6578.

WANTED: CIRCUIT manual for Grundig Satellite 2000, also service manual for Barlow Wardley XR-30. Will return. J. Hunter, 1 Moonlight Ave, Torquay 4657. (071)28-1795.

WANTED: NEC 8043 colour monitor. Contact Alan Ker, Lot 15 Panoramic Dve, Grantville, Vic. 3834.

WANTED: LISTING or copy of Synertek KTNM-2/80, 80 column terminal, program and char. gen., ROMs. A Dunn, 28 Stonehouse Ave, Camden Pk, SA 5038. (09)295-8642.

### AUDIO

FOR SALE: Toshiba KT-R2 'Walkman' type cassette recorder. Includes FM radio, metal/chrome

facility, built in stereo mic. and jacks, carry case/strap. As new. \$50 ono. Ring Geoff Pack (02)427-6304.

FOR SALE: B&W DM70 electrostatic speakers, recently recond woofers and electrostatic panels \$500 pr. Will deliver. Transcriptor Fluid Anm Instructions \$65. Koss 9B electrostatic headphones with energiser \$250. (02)869-1840.

### MISCELLANEOUS

WANTED: Copy of 80 MICRO, Issue with Bar Codes or UPC featured on cover and in mag, approx. Oct-Dec 83. A. Watson 'Ballambee' Cassills Road, Mudgee 2850.

FOR SALE: TEKTRONIX 442 35 MHz, dual channel, single timebase CRO. 4 yrs old, excellent condition. \$1200. Steward Dibbs, (02)807-4185 (h).

FOR SALE: 24 ETIs, 5 EAs 1978-83 plus 2 Capstan component draws with components plus some electrical/electronic junk. \$30 the lot. Ring Geoff Pack, (02)427-6304.

FOR SALE: 1 X BWD 539D \$500 — ono. K. Welch, 26 Petalme St, Raceview, 4305, Qld. (07)281-6480.

## SHOP AROUND

### MINIATURE SCALLOPED STYLE -ROCKER SWITCH-



PROMPT DELIVERY

#### Features Include

- SECV approved 10 amp 240 volt
- Illuminated versions
- SPST or SPDT
- Snap in panel mounting
- Panel cut-out 19.5 mm x 13 mm

#### Button Options



Broad Glow LED Spot Opaque

Available from:

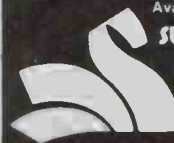

**SWANN ELECTRONICS INTERNATIONAL**  
PTY. LTD.

Melbourne (03) 544 3033  
Sydney (02) 807 1944  
N.Z. (9) 444 3620

# CLIFF S2 SERIES 6.5mm SOCKETS

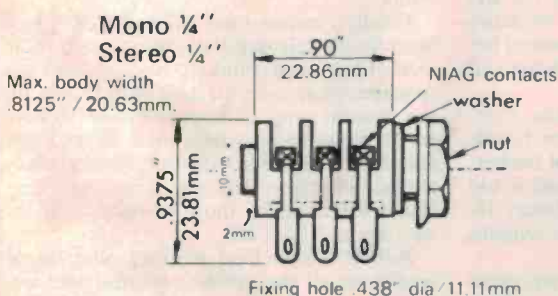

**Body Material:** High Quality Nylon.  
**Contact Material:** Nickel Silver Alloy.  
**Withstand Voltage:** 2000V DC  
**Max. Voltage:** 250V AC  
**Max. Current/Power:** 5A or 1000W  
**Nom. Contact Resistance:** 15mΩ.

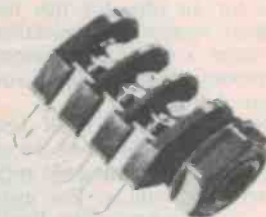

Available with switch to break or switch to make contacts in mono and stereo versions. *Wide range of colours.*

**DELSOUND** PTY. LTD. 1 Wickham Terrace (cnr. Wharf St.), Brisbane.  
Australian Distributor for Cliff. Ph: (07) 229-6155. Telex: AA44442.



**YOUR DREGS HACK** sought far and wide for an idea for this month's issue. Without success. The electronics industry has spent a sane, happy month, watching the money roll in, smiling, smiling, all the way to the bank.

Overseas things have been bubbling along as usual. Some of the press releases that have crossed this desk are slightly more bizarre than others. For instance, in the UK, the competitor to British Telecom, Mercury Communications has bought an old hydraulic company. Apparently, the London Hydraulic Power Company used to supply water to run machines throughout London. At its peak the company was supplying 7.2 billion litres of water a year to more than 8000 machines.

Even in the nation that invented the Ludites, things do change. The King is dead, long live the King. So Mercury has decided

to lay its fibre optic links in the water conduits so thoughtfully provided by the hydraulic company. The deal gives Mercury access to more than 270 miles of conduit beneath the city streets. Eat your heart out Telecom.

And mystery continues to haunt us. Consider this, dear readers: above your heads, right now, lurks the lonely celestial flasher. In spite of the best efforts of scientists too numerable to mention, the whereabouts, indeed the very nature, of the flasher remains a mystery.

All that is known is that on rare occasions, gamma ray and optical pulses of light can be detected coming from the Large Magallenic Cloud. What might cause these pulses, or why, appears a mystery. Astute readers of this column will realize the answer is obvious: Eccles is out there, mournfully flashing his torch around, sing-

ing, dirge-like: "show me the way to go home . . ."

Finally, universities around the place have finally released their results, and their load of bug eyed, blinking students into the sunshine of an unsuspecting world. Among the current crop of hopefuls: one Robert Irwin, fashionable young man about town and design engineer with an upmarket electronics magazine. He now insists on being called Mr Irwin by those of his colleagues who are not BSc, BE.

Robert is now busy working on a list of errata for all the projects he designed before he was an engineer. If you phone our technical enquiries number and ask for him personally, you'll get an intelligent answer, but only on evenly dated Tuesdays immediately before the full moon.

**Now! \$1495\***

**One style: fully loaded  
One price: \$1495\*  
One source: Hewlett-Packard**

If putting a big dent in your instrumentation budget is not for you, the HP 3478A should prove ideal for your bench or system automatic measurements. For only \$1495\* you get a fully loaded six function DMM with HP-IB—not just a starter unit you have to pay later to upgrade.



**All the right features plus HP-IB.**

You can measure dc volts, RMS ac volts, dc current, RMS ac current, and 2- and 4-wire ohms. Plus, the HP 3478A is a fully programmable HP-IB system instrument. You have the convenience of switchable front/rear terminals, scanner advance, and external trigger input. You can even automate the HP 3478A's built-in electronic "no pots" calibration.

**Costs less to own.**

When it comes to reliability, the HP 3478A is one of the best. Our field-proven reliability figures indicate over 50,000 hr MTBF (equal to 25 operational years)\*\* So intensive is our attention to quality, from design right through production, that once you install your HP 3478A chances are you won't have to repair it or worry about it for the life of your system.

**Call HP today.**

For full details on the cost-cutting reliability leader HP 3478A DMM, fill in the business reply paid card coupon opposite or ring your nearest HP office listed: Melbourne: 895 2895; Adelaide: 272 5911; Perth: 383 2188; Brisbane: 30 4133; Canberra: 80 4244; Sydney: 888 4444; Auckland: 68 7159. \*\* For 2,000-hour years, based on warranty data and other statistical projections. \* List price subject to change.

**System DMMs...HP's the right decision**



HP-IB: Not just IEEE-488, but the hardware, documentation and support that delivers the shortest path to a measurement system.



**HEWLETT  
PACKARD**

LBV 6675 HEP 90399

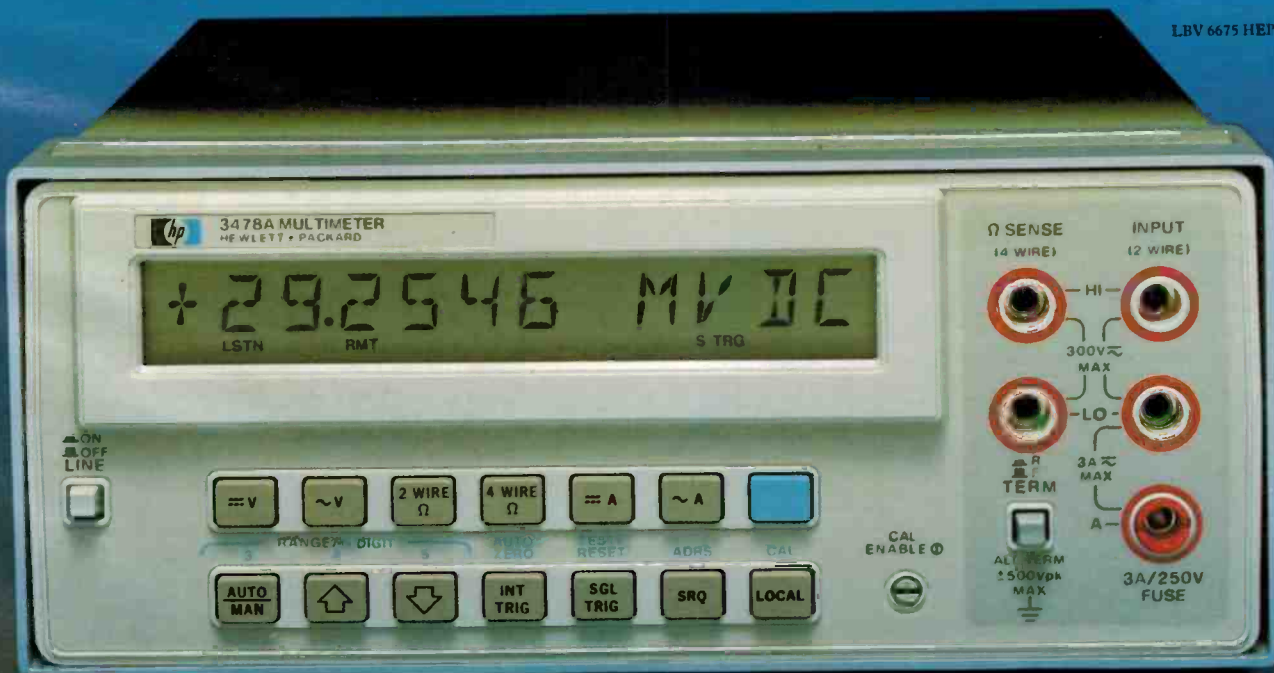

# SIEMENS

## The better the drive, the smaller the disc

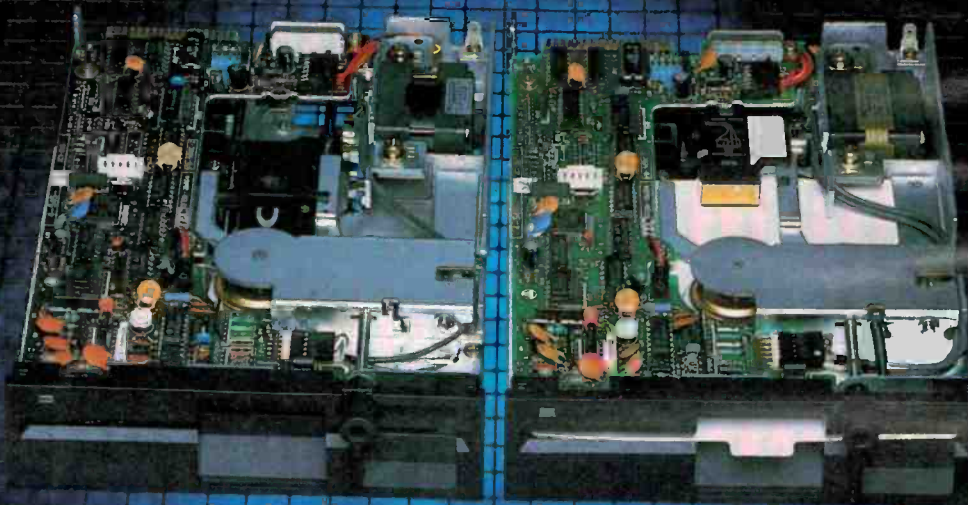

True half height 5 $\frac{1}{4}$ " floppy disc drives competitively priced from Siemens.

Designed for office electronics, business computers and OEM applications, this slim-line FB500 series has four versions with unformatted storage capacities from 250K to 1M bytes. Apart from compactness, these drives offer

fast access time by an advanced stepping motor and steel belt mechanism. The brushless direct drive DC motor is highly reliable and very quiet. The full range is now in stock together with Siemens relentless determination to provide complete service and technical assistance throughout Australia.

### Siemens Ltd.

544 Church Street, Richmond, Vic.

Melbourne: 420 7318. Sydney: 436 8730.

Brisbane: 369 9666. Perth: 362 0123.

### Distributors:

Auckland: Delphi Industries Limited, 567 258

Adelaide: R.G. Pank Pty. Ltd. 51 2411

Adelaide: Protronics Pty. Ltd. 212 3111

Brisbane: ECO Electronics, 376 5677

Melbourne: Promark Electronics Pty. Ltd. 878 1255

Perth: Reserve Electronics, 328 9755

Sydney: Promark Electronics Pty. Ltd. 439 6477

**Siemens. The discs may be flexible, but never our standards.**

646/1189A