

AUSTRALIA'S DYNAMIC ELECTRONICS MONTHLY!

Electronics Today

INTERNATIONAL

eti

See inside
**TWO GREAT
READER OFFERS**

\$2.50* NZ \$3.25
FEBRUARY 1985

**THE IMAGING REVOLUTION
NEW IMPROVED CDI
REVIEWS:
NEW NAD STEREO RECEIVER
JVC'S NEW VHS CAMERA/RECORDER**

A CLOSER LOOK AT CROs SPECIAL ETI SURVEY

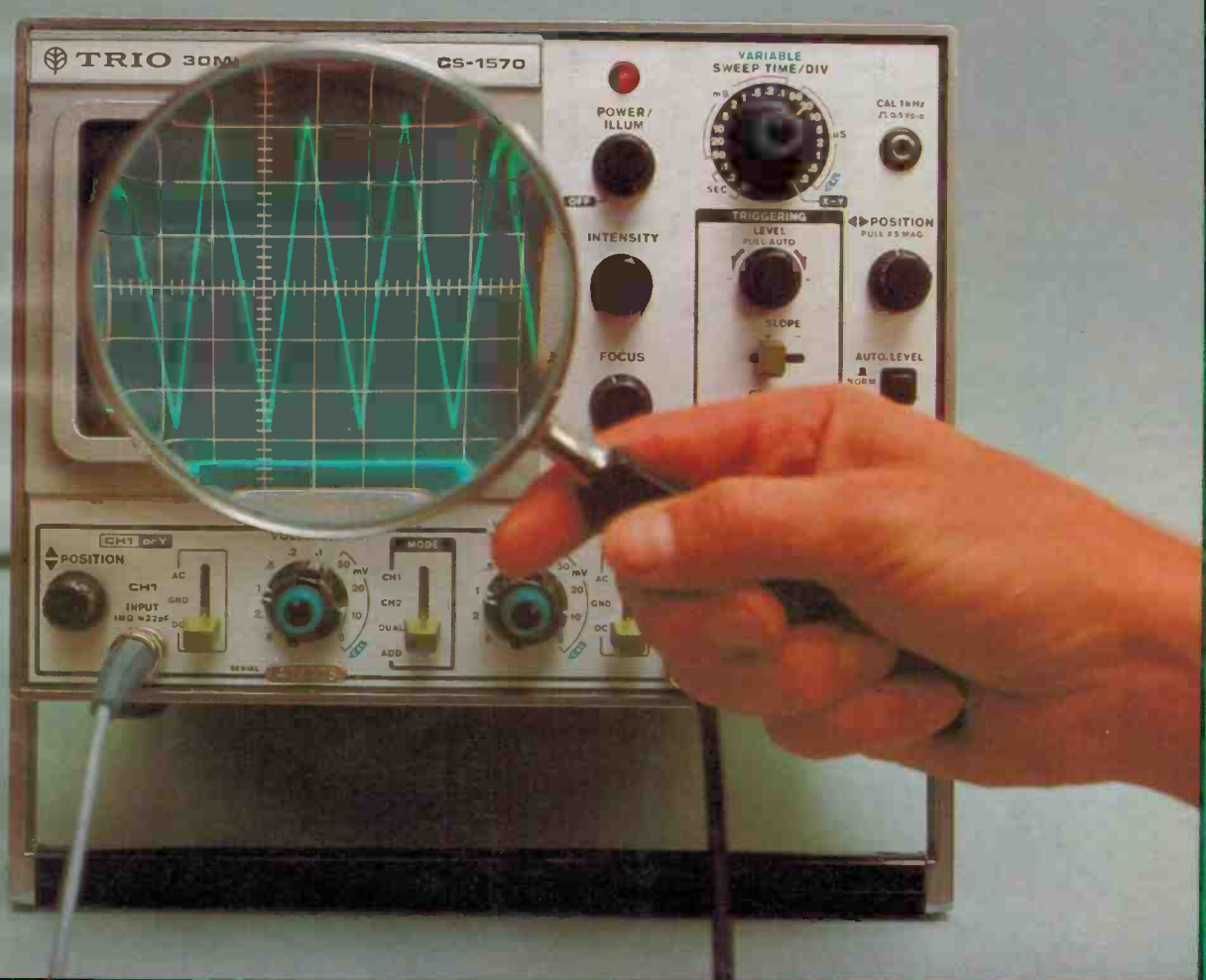

**TO BUILD: PRECISION CRO CALIBRATOR
PRINTER SWITCH FOR YOUR COMPUTER**

SPECIAL
2 FREE PROBES
 with every scope purchase!
OFFER

Save \$158.00* on the CS-2150 and \$66.00* on all other models! Offer closes end April, 1985.



WITH DRAMATIC ADVANCES BEING MADE IN THE AREAS OF BROADCAST SATELLITES, COMPACT DISCS, DESIGN AUTOMATION, FACTORY AUTOMATION, LOCAL AREA NETWORKS AND OFFICE AUTOMATION, THE CS-2150 OFFERS JUST THE RIGHT CAPABILITIES TO HANDLE THOSE PROFESSIONAL APPLICATIONS NOT COVERED BY 100 MHz SCOPES AND PRESENTS A NEW STANDARD OF PERFORMANCE IN ITS CLASS.

The model CS-2150 illustrated is our new top of the line scope. It has the following features:

1. High-sensitivity design achieves up to 1mV/div of vertical axis sensitivity.
2. High-speed signals are easily observable using the 2ns/div maximum sweep speed (using x 10 MAG).
3. Delayed sweep for partial waveform expansion.
4. Four-channel eight-trace capability and a wide range of waveform display functions.
5. A dual sweep function enables the simultaneous observation of two signals varying widely in frequency.
6. Accuracy of $\pm 2\%$ provides extremely precise waveform measurements.



7. Bright, sharp, 150 mm rectangular CRT.
8. Pushbutton switches with LEDs make operating both pleasurable and reliable.
9. Guaranteed channel-to-channel time accuracy.
10. All position controls are conveniently located on the front panel.
11. Optimum multi-clamping of video signals.



MODEL	BAND-WIDTH	CHANNELS	TRACE	SENSITIVITY	TAX FREE PRICE	TAX PAID PRICE
CS-1022	20 MHz	2	2	1mV/div	\$649.00	\$746.00
CS-1040	40 MHz	3	6	1mv/div	\$1,175.00	\$1,351.00
CS-1060	60 MHz	3	6	1mv/div	\$1,495.00	\$1,719.00
CS-2075	75 MHz	4	8	1mv/div	\$1,995.00	\$2,294.00
CS-2110	100 MHz	4	8	1mv/div	\$2,495.00	\$2,869.00
CS-2150	150 MHz	4	8	1mv/div	\$2,695.00	\$3,099.00
PROBES*						
88100	100 MHz	*Included in tax free scope price.				
99125	250 MHz					

Call or write for a detailed catalogue on any model.

PARAMETERS PTY LTD
 PERFECTION IN MEASUREMENT

SYDNEY
 41 Herbert St., Artarmon, N.S.W.
 P.O. Box 573, Artarmon, N.S.W. 2064
 Phone (02) 439 3288. Telex AA25021
 MELBOURNE
 53 Governor Rd., Mordialloc, Vic
 P.O. Box 122, Mordialloc, Vic. 3195
 Phone (03) 580 7444. Telex AA33012
 (Incorporated in Victoria)

MANAGING EDITOR

Jamieson Rowe

EDITORIAL STAFF

Mary Rennie

Jon Fairall B.A.

Geoff Nicholls B.Sc. B.E.

Peter Ihnat B.E., B.Sc.

Robert Irwin

ASSOCIATES

David Tilbrook VK2YMI

Jonathan Scott

B.Sc./B.E. (Hons) VK2YBN

DRAUGHTING

David Currie

PRODUCTION

Chris Gerrell

ADVERTISING SALES

John Whalen (National)

Cathy Darnell

Kate Stuart

ART DIRECTOR

Ali White B.A.

ART STAFF

Sharon Hill

Brian Jones

Vicki Jones

READER SERVICES

Elizabeth Barnett

Felicity Skinner

ACOUSTICAL CONSULTANTS

Louis Challis and Associates

PUBLISHER

Michael Hannan

HEAD OFFICE

140 Joynton Avenue, (PO Box 227)

Waterloo, NSW 2017.

Phone: (02) 663-9999 Sydney.

Telex: 74488, FEDPUB.

ADVERTISING OFFICES**AND AGENTS:****Victoria and Tasmania:** Virginia Salmon and

Bruce Burrell, The Federal Publishing

Company, 23rd Floor, 150 Lonsdale Street,

Melbourne, Vic. 3000. Phone: (03) 662-1222

Melbourne. Telex: 34340, FEDPUB.

South Australia and Northern Territory:

The Admedia Group, 24 Kensington Road,

Rose Park, SA 5067. Phone: (08) 332-8144

Adelaide. Telex: 82182, ADMEDIA.

Queensland: Geoff Horne Agencies, PO Box

247, Kenmore, Qld 4069. Phone: (07)

202-6813 Brisbane. Telex: AA41398

HORNAG.

Western Australia: Cliff R. Thomas, Adrep

Advertising Representative, 62 Wickham

Street, East Perth, WA 6000. Phone: (09)

325-6395 Perth.

New Zealand: Chris Horsley, 4A Symonds

Court, Symonds Street, Auckland. Telex:

NZ60753, TEXTURE. Phone: 39-6096.

Auckland.

Britain: Peter Holloway, John Fairfax and

Sons (Australia) Ltd, Associated Press

House, 12 Norwich Street, London EC4A

1BH. Phone: (01) 353-9321 London. Telex:

262836, SMHLDN.

Japan: Genzo Uchida, Bancho Media

Services, 5th Floor, Dai-ichi Nisawa Building,

3-1 Kanda Tacho 2-chome, Chiyoda-ku,

Tokyo 101. Phone: (03) 252-2721 Tokyo.

Telex: 25472, BMSINC.

**ELECTRONICS TODAY INTERNATIONAL**

is published monthly by the Electronics Division of the Federal Publishing Company Pty Limited, 140 Joynton Avenue, Waterloo, NSW 2017. Typeset and printed by ESN-The Litho Centre, Sydney. Distributed by Gordon and Gotch Limited, Sydney. Cover price \$2.50 (maximum and recommended Australian retail price only; recommended New Zealand price, \$2.95). Registered by Australia Post, Publication No NBP0407. ISSN No 0013-5216.

COPYRIGHT © 1984, THE FEDERAL PUBLISHING COMPANY

Electronics Today

INTERNATIONAL

FEBRUARY
1985

FEATURES

Made in My Image	16
The revolution in communication using images	
Special Survey: A Closer Look at CROs	40
The latest models and what they can do	
Keeping the Message Clear	81
IBM's constrained coding technique for recording, transmission	
Computerised Circuit Analysis	103
Take the sweat and guesswork out of designing amplifiers	

PROJECTS

ETI-342: Pulse-Shaped CDI System	62
All of the benefits of CDI, without the problems	
ETI-170: Precision CRO Calibrator	74
Low cost unit lets you check voltage and time settings	
ETI-742: 'Speech-Tailored' Communications Speaker	83
Tailored response improves readability!	
ETI-666: Parallel Printer Switch	92
No more plug swapping to change printers	

REVIEWS

NAD 7155 Stereo Receiver	29
The emphasis is on performance, rather than looks	
JVC GR-C1 Video Camera/Recorder	36
The VHS answer to the Betamovie!	
Powersonic NiCad Batteries	48
Just what can you expect from modern NiCads?	
Commodore Plus/4 Computer	119
Powerful new unit has built-in business software	

OFFERS

Casio Calculator, Keyboard and Computer Offer	71
ETI Mail Order Books	89,90-91,118
Benelec Digital Multimeters Offer	97

DEPARTMENTS

News Digest	8	Idea of the Month	99
Sight & Sound News	23	Commodore Column	114
New Equipment	53	MicroBee Column	116
New Components	58	Shoparound	118
Communications News	88	MiniMart	120
Computing News	109	Dregs	122
Ideas for Experimenters	98		

SONY®

Sony Precise Systems introduce a new generation in audio equipment. Systems designed to reproduce the full crystal clear glory of digital sound.

An excellence of sound never

before possible.

TA-V7

amplifier with 80W RMS per channel output.

Matching APM

(Accurate Pistonic Motion)

speakers with flat, square diaphragms designed specifically to reproduce the CD's wide dynamic range.

Front loading PS-FL99 front loading turntable – programmable, linear tracking, full auto, direct drive.

TC-V7 anti-skate, front loading cassette deck. Auto-reverse. Dolby B/C, digital linear counter, laser amorphous head.

ST-V7 quartz locked digital tuner. 8AM plus 8FM pre-sets, memory scan. Feather-touch control panels for all system components.

And cordless remote control lets you control the sound from anywhere in the room.

Matching Compact Disc Player (CDP-11S/V) is an optional extra.

Contact your nearest Sony dealer now.

Sydney (02) 887 6666

Melbourne (03) 836 4011

Brisbane (07) 44 6554

Adelaide (08) 212 2877

Perth (09) 323 8686

Launceston (003) 31 9291

Wollongong (042) 71 5777

DIGITAL-TO BE PRECISE



It's a Sony

ADVERTISERS' INDEX

Acme	70
Active Electronics	100,101
All Electronic Components	102
Altronics	52
Applied Technology	6,7
Aust. Government	19
Aust. School of Elect.	96
Data Parts	55
Delsound	86
Dick Smith	14,15,46,47,60,61,82
Disco World	55
Electronic World	120
Ellistronics	112,113
Elmeasco	OBC
Emona	45
Emtronics	110
Energy Control	21
Hewlett Packard	34
Hi-Tech Light & Sound	12,13
Jaycar	56,57
Leisure Sound	110
Lemic	59
Mayer Krieg	67
Micro Analog Gen.	59
Microtrix	94
Parameters	IFC
Philips	18
Pioneer	35
Prepak	39
Rod Irving	50,51,72 73,105,121
Rose Music	IBC
Soanar	67
Scientific Devices	80
Scope	11
Siemens	28
Sony	4
Standard Communications	39
Swann	21,55,110
Sydney Opera House	55
Vanfi	25
Len Wallis	22
W.I.A.	104
Geoff Woods	108

COVER: Design by Ali White;
Picture by Greg McBean

WHAT'S THIS — a different face on the editorial page? Sorry about that, but at least my face mightn't be too unfamiliar to many of you. Perhaps you might remember it from the past, when it appeared regularly in 'another well-known electronics magazine'.

Normally I wouldn't inflict myself on you, because good Managing Editors are supposed to lurk silently in the background. The reason for this current intrusion is that we've had a few changes here. Our old friend Roger Harrison has moved on, and for the last few weeks I've been manning the tiller of the good ship ETI myself. Seems like old times!

Fear not, though, you won't have to put up with my visage for long. From next month's issue, ETI will have a new Editor. We've been able to appoint David Kelly, who until very recently was Editor of the highly respected trade and professional journal 'Electronics News'.

David is very talented and enthusiastic. I'm confident that he'll be able not only to maintain ETI's existing high reputation but also to take it to even greater heights. So from next month, look for David's smiling face and words of wisdom on this page — plus even more goodies than before in the rest of the mag.

Talking about ETI itself, you've no doubt noticed another change already. We've gone back to having the full list of contents on the very front page, where most people seem to prefer it. This also saves some space, so we'll be able to fit more 'meat' in each issue.

Over the next few months you'll see a few more changes to the magazine. Nothing drastic; just things like simpler layouts, cleaner typestyles and a return to staple binding.

We're making these changes for two reasons. One is to make the magazine easier for you to read. The other is to try and contain our production costs, which have been rising alarmingly.

All in all, we're confident that these changes will help make ETI even better reading and value for money than it has been. So stay with us — you'll be glad you did.

Jim Rowe
Managing Editor

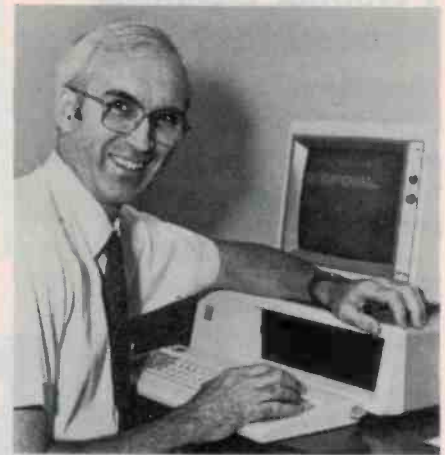

SERVICES

TECHNICAL INQUIRIES: We can only answer readers' technical inquiries by telephone after 4.30pm Mondays to Thursdays. The technical inquiry number is (02) 662-4267. Technical inquiries by mail must be accompanied by a stamped, self-addressed envelope. There is no charge. We can only answer queries relating to projects and articles as published. We cannot advise on modifications, other than errata or addenda. We try to answer letters as soon as possible. Difficult questions may take some time to answer.

GENERAL INQUIRIES: For all inquiries about back issues, subscriptions (\$24.00 for 12 months/12 issues), photocopies of articles, artwork or submitting articles, call (02) 663-9999 or write to: ETI Reader Services, 140 Joynton Avenue (PO Box 227), Waterloo, NSW 2017.

CONTRIBUTIONS: Submissions must be accompanied by a stamped, self-addressed envelope. The publisher accepts no responsibility for unsolicited material.

COPYRIGHT: The contents of *Electronics Today International* and associated publications is fully protected by the Commonwealth Copyright Act (1968). Copyright extends to all written material, photographs, drawings, circuit diagrams and printed-circuit boards. Although any form of reproduction is a breach of copyright, we are not

concerned about individuals constructing projects for their own private use, nor by bands (for example) constructing one or more items for use in connection with their performances. Commercial organisations should note that no project or part project described in *Electronics Today International* or associated publications may be offered for sale, or sold in substantially or fully assembled form, unless a licence has been specifically obtained so to do from the publisher, The Federal Publishing Company, or from the copyright holders.

LIABILITY: Comments and test results on equipment reviewed refer to the particular item submitted for review and may not necessarily pertain to other units of the same make or model number. Whilst every effort has been made to ensure that all constructional projects referred to in this edition will operate as indicated efficiently and properly and that all necessary components to manufacture the same will be available, no responsibility is accepted in respect of the failure for any reason at all of the project to operate effectively or at all whether due to any fault in design or otherwise and no responsibility is accepted for the failure to obtain any component parts in respect of any such project. Further, no responsibility is accepted in respect of any injury or damage caused by any fault in the design of any such project as aforesaid.

For all small and Personal Business Management

'Because nowadays fast and efficient retrieval and processing of information is paramount to the success and growth of a progressive organisation.'

The microbee Small Business Success Kit is an ideal package for serious small business users who want more than just a 'big name' accounting machine. microbees 128 K of Dynamic RAM and dual 400K disk drives process pages full of information in seconds. The microbee High resolution Amber Screen monitor and Dot Matrix or Daisy Wheel printers display and record your spread sheets and wordprocessing quickly and accurately.

microbee's now famous Bundled Software provides you with a comprehensive library of programs for all Small Business needs. Programs include Wordstar/Mailmerge 3.3, Microsoft Basic, Telcom Communications Package and a full range of support utilities training guides and tutorials.

128K microbee, dual 400K slim line floppy disk drives, Hi-res green screen monitor, bundled software and manuals . . . **\$1995** incl. sales tax.

With microbee dot matrix parallel printer and microbee Pro amber monitor . . . **\$2395** incl. sales tax.

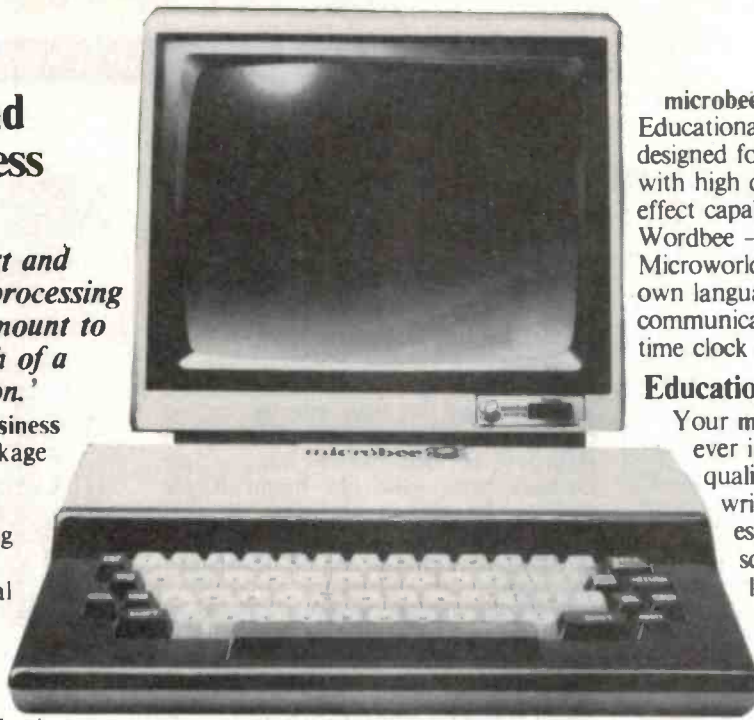

A BEE FOR ALL REASONS

For Education

'Because Education is a Priority and your children deserve the best.'

It is no coincidence that microbee's educational software is entitled "Learning Can Bee Fun". The microbee has proved that learning can be fun and by doing so has gained the endorsement of the Australian Schools Commission and the majority of Depts. of Education Australia wide, the Education Department in Israel, and more recently the Swedish Schools Dept have chosen microbee after months of stringent tests and stiff opposition from the big American, British and Swedish manufactures.

microbee is indeed Australia's own Educational Personal Computer, designed for the classroom and home with high quality graphics and sound effect capabilities, built-in software like Wordbee — wordprocessing, Microworld Basic — the microbee's own language and Telcom the communications package with a real time clock and alarm features.

Educational Software Support

Your microbee is supported by an ever increasing range of high quality software developed and written by Australians especially for Australian schools and students. A full list of available teacher support resources for the microbee is available from your nearest microbee Technology Centre.

microbee 16K Educator . . . **\$449**

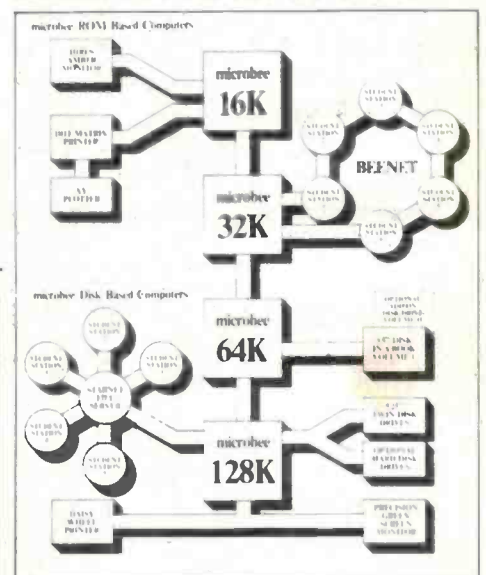

For Communication

'Because we need to communicate our ideas and data.'

From home to office, around your network or around the world, with microbee you can tap into Bulletin

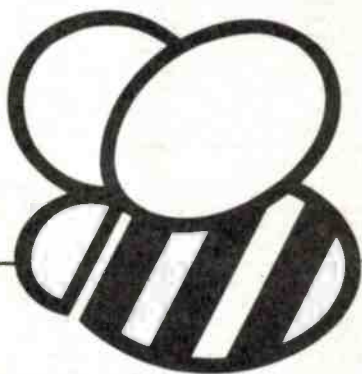

microbee®



DIRECT ORDERS
PHONE (02) 487 2711
TELEX AA72767
APPLIED TECHNOLOGY
RETAIL PTY LTD

boards and benefit from Public Domain software.

Share your experience and learn from others treading the same path you choose.

microbee 32K Communicator Workstation . . . **\$599.00**
includes 32K microbee Series III and Hi-res Green Monitor.

Available separately:

microbee 32K Series III. . . \$499.00
Hi-res.Green Monitor . . . \$149.50
Hi-res.Amber Monitor . . . \$169.50
Swivel Base \$24.50



NEW 3.5" Disk Computer -in-a-Book

The smartest new development in the Microcomputer World is the new high density low cost 3.5" Disk drive. Already standard on many 'big name' systems the 3.5" disk has the same or more capacity than the standard 5.25" disk, but occupies only 30% of the volume.

The microbee Computer-in-a-Book is available in matching volumes expandable to meet your growing needs.

microbee-Computer-in-a-Book VOLUME 1 includes microbee 64K, single 3.5" disk drive and software on diskette including Demonstration, MicroWorld Basic, Wordbee, Telcom and CP/M with Utilities — a matching manual is supplied.

VOLUME 1 \$995.00

VOLUME 2 is an add-on disk drive in a matching volume

VOLUME 2 \$345.00

For experiments and personal development

'Because microbee is the ideal Hackers micro'

With a wealth of experiments and Hackers hints being published regularly in several enthusiasts magazines and one-shot publications. See the microbee Hackers Hand Book. Explore Robotics, Music and speech synthesis, tune into Weather map facsimiles and decode Radio Teletype information. The scope is limited only by your imagination.

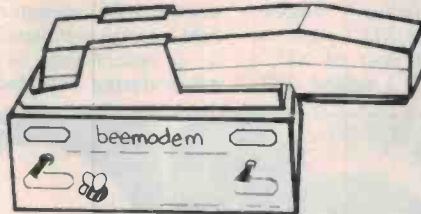

For games and entertainment

'Because playing is the root of all learning.'

Fight in space, land a helicopter — explore the Dungeons of Khan, or is a challenging game of Chess more your speed. Whatever turns you on microbee's high resolution picture and



**128K Small
Business Computer**

built-in sound effects will keep your microbee turned on for hours and hours everyday.

Upgradeability

When you buy a microbee personal computer rest assured you have made the right decision. Your microbee will never become obsolete — on the contrary your microbee is fully upgradeable and can grow from 16K to 32K to 64K and even to 128K. Disk drives can be added as can a whole host of useful and interesting peripherals such as printers, plotters and modems. Whatever level you choose to start at your microbee will grow with you providing challenges and encouragement along the way.

Quality Control and Service

microbee is designed and manufactured in Australia under strict computer controlled standards and is backed by a strong national service team operating from West Gosford and through microbee Technology Centres Australia wide.

microbee technology centres

N.S.W.
1 Patterson Ave, Waitara 2077, N.S.W.
Phone (02) 487 2711

VIC.
729 Glenferrie Rd, Hawthorn 3122, Vic.
Phone (03) 819 5288

W.A.
141 Stirling Highway, Nedlands, W.A.
Phone (09) 386 8289

S.A.
151 Unley Road, Unley 5061, S.A.
Phone (08) 272 1384

QLD
455 Logan Road, Stones Corner, 4120 Qld.
Phone (07) 394 3688

FACTORY
Koala Crescent, West Gosford 2250.
Phone (043) 24 2711

Authorised Dealers in:

- Coffs Harbour (066) 52 7530
- Lismore (066) 21 8180
- Melbourne (03) 233 9665
- Townsville (077) 75 4000
- Cairns (070) 51 4341
- Milton (07) 371 6888
- Port Lincoln (086) 82 2666
- Mount Tom Price (091) 89 1383
- Launceston (003) 31 7890
- Wauchope (065) 85 3311

ANZCAN — the new link

Long distance cables are not dead. Now that the earth is girdled with satellites one might be forgiven for thinking that they should be, but the opening of ANZCAN proves that there is still a place for old solutions.

The 14 000 km undersea communications cable was launched recently with a conversation between Communications Minister Michael Duffy in Sydney and his opposite number in Vancouver, Marcel Masse.

A message from Queen Elizabeth was beamed via satellite to simultaneous opening ceremonies in Sydney, Auckland, Suva and Vancouver.

The big advantage of cables over satellites for telephony is that the cable eliminates the time delay caused by the tremendous distance up to the satellite. This delay is unavoidable, since it's caused by the finite time taken for the radio waves to travel up and back.

Even at the speed of light, this delay amounts to some quarter of a second. It gets longer if there is more than one satellite path in a particular circuit, as there would be with a circuit going around the world, say from Australia to Europe.

Another advantage of undersea cables is that they last longer. ANZCAN is specified to last for 25 years. Aussat is specified for only seven. The main reason for this is that satellite power systems fail over time as the efficiency of solar cells goes down.

ANZCAN runs from Sydney, via Norfolk island and Fiji to Vancouver with a spur cable running from Norfolk to Auckland. At maximum capacity it can

carry 1300 telephone circuits. Total cost was \$400 million. The cable is owned by a 14 nation consortium and replaces the COMPAC cable, which could only carry 80 circuits.

The repeaters for the cable were built in Sydney's western suburbs at the STC plant in Liverpool. The cost of STC's contract was \$39.2 million. STC

had to spend \$10 million to build a clean room for the manufacture of the repeaters.

The manufacture of such repeaters is an exacting task, ranking with satellite and other advanced technologies. Essentially, the specification calls for a package of amplifiers capable of giving maintenance free service on the sea bed for approximately 25 years. Failure of any of the nearly 1000 repeaters on the cable would completely disable it, so special care needs to be taken during manufacture. Re-

dundancy is also built into the design, using the philosophy developed for space craft circuits.

With ANZCAN, Australia became only the fifth western nation with the capability to manufacture repeaters, along with the US, Britain, Japan and France.

STC has won the contract for the construction of repeaters for the next big cable out of Australia, the AIS cable, linking Australia, Indonesia and Singapore.

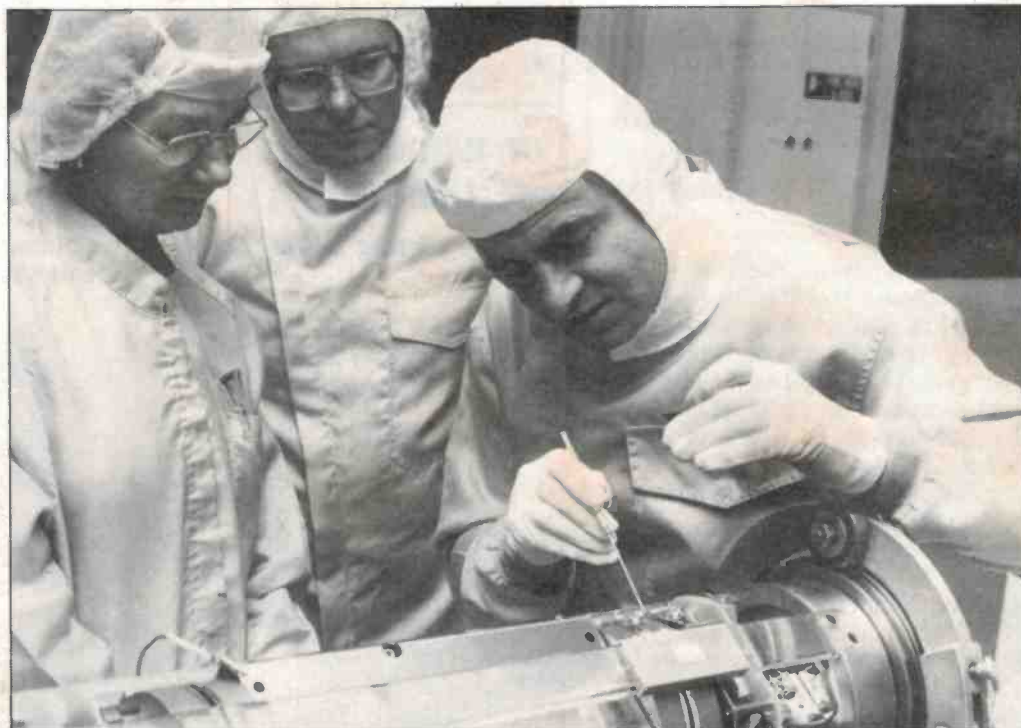

Swedish niche for the 'Bee

After some three months of intensive testing and evaluation by the Swedish School Department it was announced that Microbee is to be one of the very few approved computers used in Swedish schools.

Requirements for getting approval are extremely demanding and even brand names such as Apple and Apricot and Sinclair failed to fulfill them.

Among the approved computers Microbee was by far the most cost efficient.

This will, no doubt, echo strongly and positively throughout the rest of Europe.

Well done Microbee.



micro-electronics, bio-engineering and new materials.

BRIEFS

The International Trade Fair for New Technology is to be held in Ghent, Belgium, from 25 February to 3 March 1985 inclusive. This fair was initially held in Ghent in May 1983, and its outstanding success ensured worldwide participation for 1985. The three cornerstones of the fair are

Arlec Pty Ltd has now appointed an agent for north west New South Wales. Redman Agencies which is based in Newcastle will have commenced operating as the Arlec Agent from October 1, 1984. They will stock the full range of Arlec products, servicing customers from Woy Woy to Grafton and west to Forbes. Customers are invited to contact Redman Agencies at 11 Hall Street, Newcastle NSW 2302. (049)25896.

New video projection system

A new, versatile colour video projection system, the National TC-10010 PSN, has been launched in Australia by GEC. Designed for front and back projection from a ceiling or bench mounting, the unit will reproduce PAL, SECAM and NTSC (4.43) VTR signals onto a range of flat or curved screen sizes from 1.3 m (50") to 2.5 m (100") diagonal. Each projector comes complete with a full-function remote control unit.

The new projection system is being marketed by GEC Australia Limited Video Systems Division. They believe the versatility of the TC-10010 PSN makes it ideal for presenting to small or large audiences in a variety of settings whether at conferences, exhibitions or sales/training seminars.

The TC-10010 PSN has been designed to automatically detect PAL, SECAM or NTSC (4.43) input signals and reproduce

them in the correct mode. If automatic detection is not required, the unit can be preset for any one format.

However mounted, the new National projector is claimed to give a high quality picture with flat or curved screens from 1.3 m (50") to 2.5 m (100") diagonal image size. Three special high-brightness 7" projection CRTs and f 1.1 lenses give a high resolution of 450 lines and luminous flux of 170 lumen. A complete built-in cross hatch generator is included for precise convergence adjustment without the need for external sync.

Each projector comes with a remote control unit (pre-wired to 1.5 m but available with optional 15 m, 30 m and 50 m cables) for routine alignment and on-the-spot adjustment. Power on/off, brightness, colour, contrast, vertical hold and static convergence can thus be conveniently controlled, re-

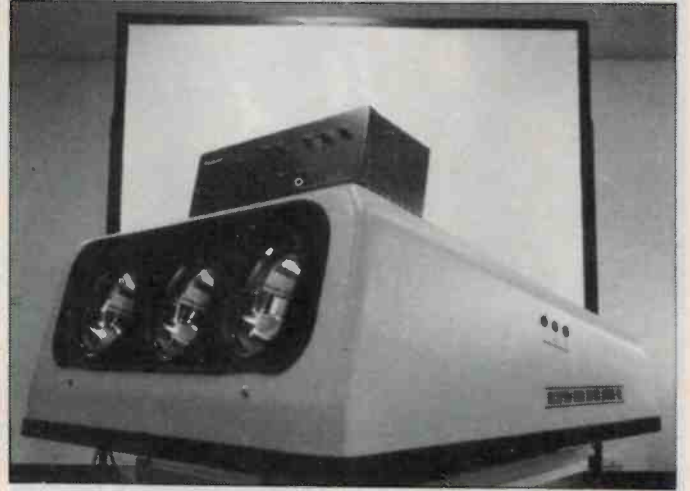

New National video projection system designed for front or back projection, and ceiling or bench mounting.

gardless of the projector mounting position.

The National TC-10010 colour video projection system is avail-

able from GEC Video Systems Division at 2 Giffnock Ave, North Ryde NSW 2113. (02)887-6222.



"... FEEL THE WIDTH!"

IBM (East Fishkill, N.Y.) has announced the production of experimental 8" (203 mm) diameter silicon crystals, the largest crystals ever produced by IBM.

The East Fishkill site, one of IBM's most advanced semiconductor and packaging manufacturing and development facilities, houses the industry's largest crystal pullers for producing silicon crystals from which computer chips are built.

Standing more than two stories high and weighing nearly nine tons, each of the crystal pullers regularly manufactures crystals that yield 5" (127 mm) wafers. The wafers are eventually processed and cut to produce individual computer chips.

The crystals are manufactured through a number of complex processes. Chunks of purified silicon, derived from common sand, are reduced to a liquid in temperatures exceeding 1400°C, 25 per cent as hot as the sun. At this point, a silicon 'seed' the size and shape of a pencil, is dipped into the molten silicon. The seed is then lifted slowly, pulling with it a trail of molten silicon which hardens to form a crystal.

The crystal column is drawn up into the cooling chamber of the crystal growing machine and eventually removed. The diameter of the crystal is determined by the temperature of the molten silicon and the speed at which the seed is lifted. The entire process takes about 24 hours.

The finished crystal is ground into a solid cylinder and sliced into wafers about 2 mm thick. The wafers are polished to a mirror-like shine in preparation for chip fabrication. Then the wafers are subjected to hundreds of manufacturing processes that build computer chips on their surfaces. The chips contain thousands of electronic circuits.

Five inch wafers hold nearly 850 chip sites. The experimental 8" wafers have the capacity to hold more than 2000 chip sites, with an expected increase in productivity and reduction of overall cost per chip.



Arianespace to launch Aussat

The Government's satellite-towing company, Aussat Pty Ltd, is formally to sign a \$A24 million contract with the European company Arianespace to launch Aussat's third domestic satellite.

According to the Minister for Communications, Mr Michael Duffy, and the Minister for Defence Support, Mr Brian Howe, Australian industry and OTC (Australia) would receive orders for work and services valued at about \$18 million through offsets commitments agreed to by the Commonwealth and Arianespace. Offsets work would include the manufacture in Australia of aluminium and steel forgings and castings valued at between \$7.5 and \$9 million for the Ariane family of space launch vehicles; and this will include, if required, the transfer of appropriate technology to Australian companies to enable forgings and castings manufactured in Australia for the Ariane launch vehicles to meet the stringent quality control requirements for space vehicles.

The Ministers said Arianespace would also arrange the placement of orders on OTC worth \$8.5 million for tracking and telemetry services at Carnarvon and Perth between 1985-1996 with possible extensions.

The contract provides a

launch window extending from mid 1986 to mid 1988. The arrangements under which the third launch can take place in mid 1986 are consistent with the Government's recently announced initiative to provide commercial direct broadcasting to the remote areas of Australia at the earliest possible date.

Arianespace will use an expendable Ariane three-stage rocket to launch the satellite. "The Ariane launch site, located at Kourou in French Guiana, close to the equator enables the satellite to be placed directly into its geostationary transfer orbit 36 000 km above the equator with considerable savings in the fuel carried on board the satellite and thus increasing the life of the satellite by more than two years," said Mr Gosewinckel, General Manager of Aussat.

Arianespace is a private European commercial consortium formed in 1980 and jointly owned by thirteen major European banks, thirty-six European aerospace and electronics manufacturers, and the French National Space Agency.

For further information contact Mr W G Gosewinckel, General Manager Aussat, (02)238-7800 or Mr Leighton Farrell, Manager — Public Affairs, Aussat, (02)238-7892, (02)683-1261 (ah).

New aids for making pc boards and labels

Melbourne manufacturer Sesame Electronics is now producing three inexpensive pieces of equipment to assist in the manufacture of pc boards in the small lab or at home.

The Maxilight, the Etching Station, and the Squarecutter are respectively an ultra-violet light exposure box, a quick means of etching a pc board, and a simple way to cut blank material into rectangles.

The Maxilight is supplied in kit form, and full assembly and operation instructions are provided. It will develop artwork up to 150 x 180 mm, and is priced at \$139.

The Sesame Etching Station comprises an adjustable heater/blower mounted on a base, directing hot air into a plastic dish that contains the pcb and

the etching solution. The heating of the fluid, and the moving currents produced by the fan, greatly speed up the action so the etching is completed, hands free, in about 10 minutes. The Etching Station is priced at \$39.

The Squarecutter will enable a pcb to be cut into a rectangle without the bother of squaring, scribing, and filing. To use it you place the material on the platform and feed it into the saw, then turn it against the perpendicular fence and repeat the cutting. A rectangle is quickly produced. The Squarecutter is priced at \$39.

All prices quoted include postage. For a brochure containing more information contact Sesame Electronics, PO Box 452, Prahran, Vic 3181. (02)527-8807.

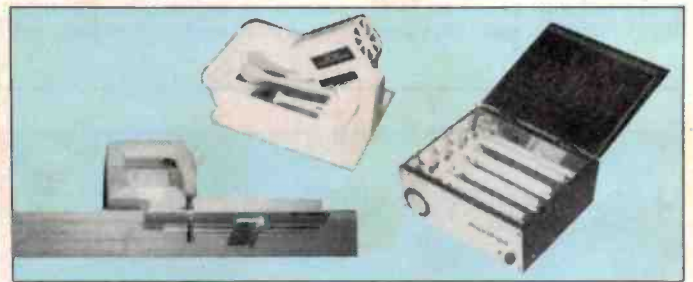

Robot makes 'phones

Standard Telephones and Cables Pty Ltd (STC) has installed a robot at its manufacturing plant in Alexandria, Sydney, to do work previously performed by an operator in the manufacture of telephone handsets.

The robot is a 5-axis ASEA Rb 60, which STC selected because of its absence of hydraulics, its quietness and its physical size.

While STC has always been in the manufacturing forefront and has installed at its Alexandria plant many items of equipment employing new technologies aided by various pick and place robots, the ASEA Rb 60 is the company's first application of a large scale universal robot.

Installed in the plastics moulding division, the robot forms part of an integrated system. Be-

fore the robot was introduced, each moulding machine was attended by an operator, who was required to precisely locate the removable core pieces, maintaining a high degree of precision throughout the shift as well as perform the arduous task of removing the mouldings, operating the guarding system and performing supplementary operations. The robot has now taken over those tasks and performs ten functions in one complete operating cycle rearranging and manipulating the required objects.

The complex is safeguarded by a series of sensors which protect the tooling and equipment against operator mislocation of the core pieces or any malfunction of the moulding machines, robot or rotary table.

NOW a Production Quality 20W Iron that air cools your fingers..



SAFETY STAND
MODEL STS 2

MODEL PH20



SCOPE COMMODORE
MODEL PH20 370°C* 240VAC.

- Designed for continuous production line use
- for students • serious hobbyists. A professional quality non-temperature-controlled soldering tool. Earthed tip and barrel for component safety.

*Idling temperature subject to variations in line voltage and ambient conditions.

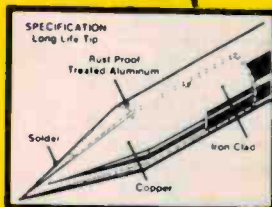

LONG LIFE IRON PLATED TIP - fitted as standard - quicker & cleaner soldering by avoiding corroded tip.

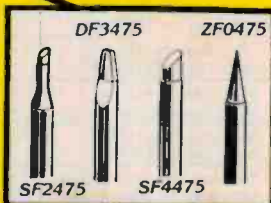

4 INTERCHANGEABLE TIPS - let you match the tip's heat transfer rate to each job. All 370°C* idling temp.

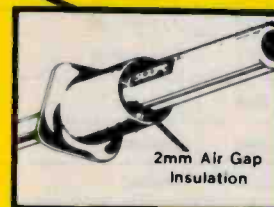

AIRCOOLED GRIP - for continuous soldering comfort - hour after hour.

N.S.W.
Avtek Electronics (02) 427 6688
A E Baker & Co Pty Ltd (02) 621 0044 AA26788
J Boomer & Co Pty Ltd (069) 21 4644
Auslec Broue (02) 709 2577 AA71512
Collier Tools (Australia) Pty Ltd (02) 763 1888 AA23864
Martin De Launay Pty Ltd (02) 267 1055 AA26679

S.A.
Bee Jay Electronics (08) 352 5959
Gerard & Goodman Pty Ltd (08) 223 2222 AA 88983

QLD.
Auslec-Austral (07) 262 2811 AA40418
BWD Audiotechnics Pty Ltd (07) 44 7566 AA145138
Dunlop IBC (07) 892 0011 AA41561
Elphinstones Ltd (07) 52 0171 AA42503
Haymans Electrical Pty Ltd (07) 369 8400 AA44311
St Lucia Electronics (07) 52 7466 AA42883

WA.
Atkins Carlyle Ltd (09) 277 0511 AA93750
Letco Trading Company (09) 387 4966 AA94396

VIC.
The Australian School of Electronics Pty Ltd
(03) 523 5622 AA30625
Ballarat Electronics Supplies (053) 31 1947 AA37435
Ellistronics Pty Ltd (03) 561 5844 AA37758
Radio Parts Group (03) 329 7888 AA32980
Teleparts Investments Pty Ltd (052) 21 7085
McGraths Electronics (03) 347 1122 AA31001
Middendorp Electric Co Pty Ltd (03) 328 3233
(plus branches)

SCOPE
338 1566
TLX 38318



Hi-TECH LIGHT AND SOUND

HIRE * SALES * SERVICE

63 Hardgrave Road, West End 4101
 Postal Address: P.O. Box 377, West End
Phone: (07) 44 4971

**SHOWROOM HOURS: Mon-Fri. 8.30am to 5pm
 Saturday. 8.30am to 12 noon**



HIGH-FREQUENCY HORNS							
Model	Type	Low-Frequency Limit	Entry Diameter or Adaptor Required	Dimensions (cm) (Height x Width X Depth)	Weight		
2028	Exponential	1200 Hz	1.8 cm (Use 1034 Driver)	12.0 x 28.0 x 18.5	0.95 Kg		
2040	Exponential	800 Hz	2.54 cm (Use 1044 Driver)	16.5 x 39.2 x 19.0	1.6 Kg		
2052	Exponential	500 Hz	3.56 cm (Use 1072 Driver)	19.6 x 49.4 x 24.0	3.4 Kg		
2042	Exponential	800 Hz	3425 (Use 1044 Driver) 3435 (Use 1072 Driver)	17.0 x 40.2 x 19.6	2.0 Kg		
2048	Sectoral	800 Hz	3425 (Use 1044 Driver) 3435 (Use 1072 Driver)	22.0 x 47.5 x 34.4	5.2 Kg		
2060	Sectoral	500 Hz	3425 (Use 1044 Driver) 3435 (Use 1072 Driver)	26.6 x 60.0 x 39.5	7.6 Kg		
2070	Multicell	1000 Hz	3835 (Use One 1072 Driver) 3870 (Use Two 1072 Driver)	32.0 x 73.5 x 46.5	16.4 Kg		
HIGH-FREQUENCY DRIVERS							
Model	Nominal Impedance	Power Capacity	Frequency Response	Sensitivity (dB/1m, 1W)	Voice Coil Diameter	Dimensions (cm) (Diameter x Depth)	Weight
1034	8 ohms	50 Watts	1200 - 18000Hz	102 dB	3.44 cm	10.8 x 6.6	1.7 kg
1044	8 ohms	75 Watts	800 - 15000Hz	104 dB	4.44 cm	12.6 x 8.1	3.6 kg
1072	8 or 16 ohms	100 Watts	500 - 12000Hz	106 dB	7.20 cm	16.3 x 9.2	7.0 kg
NETWORKS							
Model	Crossover Frequency	Impedance	Power Capacity	High Frequency Attenuation	Dimensions (cm) (Height x Width x Depth)	Weight	
4012	1200 Hz	8 or 16 ohms	100 Watts	0-4-8-12 dB, switch	16 x 8 x 7.0	0.5 Kg	
4008	800 Hz	8 or 16 ohms	150 Watts	0-4-8-12 dB, switch	20 x 10 x 7.0	0.9 Kg	
4005	500 Hz	8 or 16 ohms	200 Watts	0-4-8-12 dB, switch	19 x 15 x 8.5	1.4 Kg	

PROFESSIONAL SOUND REINFORCEMENT COMPONENTS

HORNS

AS 2028 Exponential Horn 12"	42.50
AS 2040 Exponential Horn 15"	79.80
AS 2042 Exponential Horn 16"	79.80
AS 2052 Exponential Horn 19"	110.20
AS 2048 Sectoral Horn 18"	219.70
AS 2060 Sectoral Horn 24"	291.20
AS 2070 Multicell Horn 29"	736.95
AS 4012 Crossover Network 100W	44.75
AS 4008 Crossover Network 150W	57.75
AS 4005 Crossover Network 200W	102.40
AS 1034 50W Driver	84.00
AS 1044 75W Driver	126.00
AS 1072 100W Driver	204.75
AS 3425 Adaptor Single	25.79
AS 3435 Adaptor Single	25.79
AS 3825 Adaptor Single	40.10
AS 3870 Adaptor Twin	80.60
AS 1034D Replacement Diaphragm	14.70
AS 1044D Replacement Diaphragm	22.40
AS 1072D Replacement Diaphragm	35.75
AS KHS 105A Tweeter	7.50

Mail Orders + Installations + Other Info

CREDIT CARDS

Bankcard, M/Card, AGC Credit Line



CLUB INSTALLATIONS

Excellent service through Australia.

MAIL ORDERS (AUST)

Add packing & post (P&P) as follows
(Aust. only) MINIMUM MAIL ORDER \$25

Goods \$25-\$49	P&P\$3.50
Goods \$50-\$99	P&P\$5.00
Goods \$100-\$149	P&P\$7.50
Goods \$150-\$199	P&P\$10.00

Goods \$200 + Add 5% to Order value
or otherwise by individual quotation.
Send to: **HI-TECH LIGHT & SOUND**
63 Hardgrave Rd. West End Q. 4101.



Music computer to win

Sonics, Australia's magazine for music-makers, is running an interesting competition in its January/March issue. The prize is Yamaha's new MSX computer, the CX5M, plus a 49-note music keyboard, three software packages and a Taxan Vision-EX colour monitor, worth over \$1600 in total!

As well as being an MSX-standard computer with 32K ROM and 48K RAM (16K VRAM), the CX5M incorporates Yamaha's 'FM voice generator' chip, which provides eight octaves of high-quality sound and the ability to produce eight different voices at once. In other words, this computer is a real music-making tool.

The accompanying software is very useful too. An FM Music Composer allows you to write music onto on-screen staves from either the typewriter or the music keyboard in up to eight 'parts' with full control of time

and key signatures, tempo, dynamics and phrasing. Compositions can then be played by the CX5M, or by up to eight other instruments equipped with MIDI (the Musical Instrument Digital Interface) under the control of the CX5M.

An FM Voicing program allows you to edit and alter the pre-programmed voices or create totally new ones; and a Music Macro program adds a special set of commands to the MSX BASIC language, permitting control of the FM voice generator from within BASIC programs.

The Taxan/Kasa Vision-EX monitor has been kindly donated by Colex Australia, and is an excellent medium for reproducing the CX5M's comprehensive 16-colour graphics, although a conventional colour TV can also be used.

Entry forms are to be found in the January/March issue of Sonics magazine.

Defense fairs to boost Australian exports

A recent successful series of Australia-United States defense contractors fairs held in five mainland capitals during November last year are expected to lead to Australia's defense industry becoming a significant supplier of military spares and electronic equipment to the US Defense Department and its prime contractors.

Some 70 US participants, representing logistic support agencies and contractors, visited Brisbane, Perth, Adelaide, Melbourne and Sydney seeking Australian suppliers for goods from metal castings to printed circuit boards for electronic equipment. The Americans carried actual bid packages to discuss with Australian businessmen. The US defense department budget for military spares alone this year is worth \$US30 billion. "Judging by the enthusiastic response from Australian industry representatives, the US visitors did not return home disappointed," Mr Howe, Minister for Defense Support said.

This was underlined by the overall attendances at the fairs. Some 718 Australian defense industry senior managers, repres-

enting 460 separate companies, attended the series of one-day fairs. Of these, 325 companies lodged serious inquiries concerning contract opportunities with the United States Defense Department (which has a 1985 budget projection of some \$272 billion).

Mr Howe said the fairs had done much to show the US Defense Department and its prime contractors that Australia possessed skills which could be used for sound commercial reasons. "The US visitors were clearly impressed by the capability of our defense industries, particularly the prices and short lead times being quoted," he added.

The US Secretary of Defense, Mr Weinberger, has ordered a wide range of reforms in procurement practices, and US Congress also recently enacted the most significant changes in US procurement laws in over 40 years.

Mr Howe said the reforms paved the way for more competition from overseas suppliers for US Defense Department contracts.

More bytes

First shipment sold out in days . . .
So popular we've had to air-
freight new stocks in . . .
The greatest value you'll ever
see . . .

That's the new Bondwell 14 Portable computer: EXCLUSIVE to Dick Smith Electronics

Simply brilliant! That's the all-new Bondwell 14 portable personal computer. Small wonder it has become one of America's top-selling computers in just a few short months — and now the same thing is happening here in Australia.

It's everything you've ever wanted in a computer and much, much more besides: small enough to go anywhere with you, yet large enough to do virtually any computing job.

This incredibly powerful personal portable operates from the world-standard CP/M system: which means there will always be an incredibly large range of software available for it. For virtually any purpose.

That's if you ever need any other software: the Bondwell 14 comes with over \$1200 worth of top quality business software (including Wordstar word processing!).

Look at what else you get:

- Twin double density, double sided disk drives inbuilt (360K capacity each)
 - 9in amber screen inbuilt — for minimum glare and fatigue
 - Standard parallel and twin RS-232C interfaces inbuilt
 - 16 user definable keys for incredibly easy use
 - CP/M version 3.0 including a host of utility software — even a SPEECH synthesiser (it can read to you in English!)
 - Ergonomically designed keyboard & durable cabinet for complete portability
 - PLUS over all this famous Micropro bundled software: Wordstar, Calcstar, Mailmerge, Datastar, Reportstar — worth over \$1200.00!
- Cat X-9000

**OVER \$1200 WORTH OF
SOFTWARE FREE!**

All this
for **\$2295**
only

*Or from \$233 deposit and \$18.23 per week over 48 months to approved applicants. Commercial Leasing also available!



Dick Smith Electronics Pty Ltd

COMPUTERSTOP 

Your one stop computer shop at your

for your bucks!

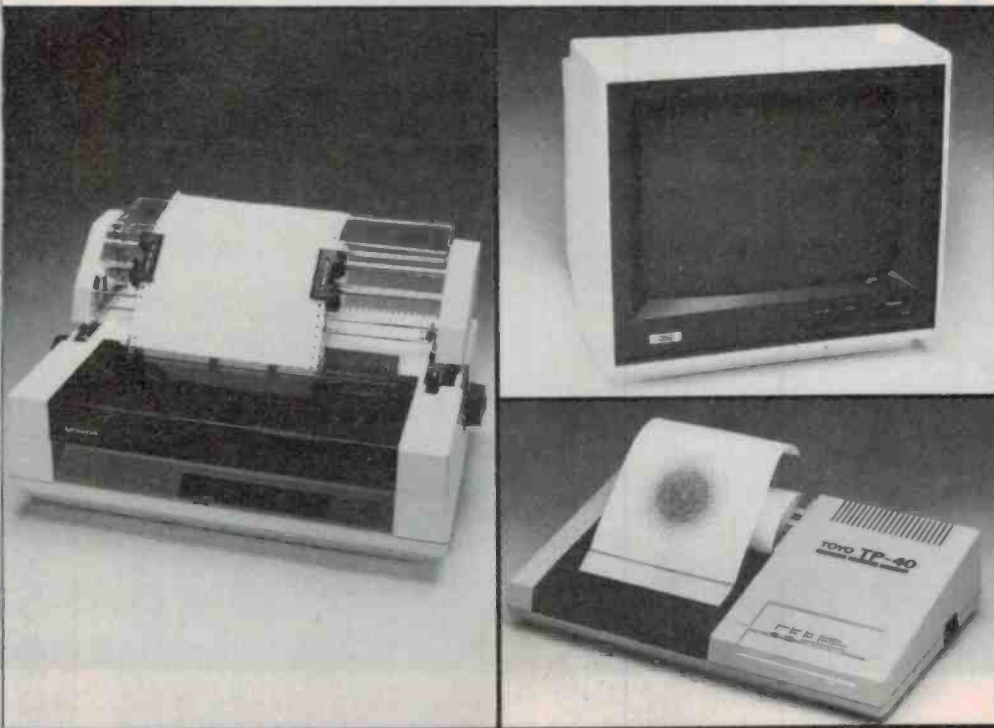

Uchida Daisywheel Printer

Top quality printing at a budget price. Prints at 18 cps and offers a choice of 3 pitches plus proportional. Standard Centronics type interface. Cat X-3270

Save \$120
Now only **\$575**

Tractor feed shown is optional (Cat-3273 or \$99.50).

Quality Japanese Hi-Res Monitors

Green: X-1222
Amber: X-1227 **\$249** each

TP-40 Four Colour Printer Plotter

Incredible performance at a bargain price. Centronics type interface. Cat X-3245

LAST YEARS PRICE \$229
Now only **\$99**



Apple II software compatible CAT!

Australia's best value 64K Computer. That's the CAT. It's the best of both worlds: the very latest and most powerful hardware, plus the ability to run a very broad range of tried-and-proven software. If you want a machine which is software compatible with thousands of popular programs and which is supported by a reputable dealer, our CAT with emulator is good value. Check the CAT out at your nearest Dick Smith Electronics Computerstop. It purrs.

Save \$232 on CAT system!

	Cat. No.	Normally
Basic CAT Computer	X-7500	\$ 699.00
Disk Drive	X-7505/6	\$ 349.00
Disk Controller	X-7510	\$ 149.00
RF Modulator	X-7550	\$ 34.90
		\$1231.90

SPECIAL OFFER!
VALUE AT ONLY **\$999**

*Or \$81 deposit and \$8.31 per week over 48 months to approved applicants.

Dick Smith Electronics Pty Ltd

COMPUTERSTOP



nearest Dick Smith Electronics Centre.

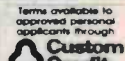
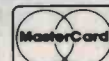
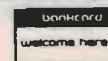

MADE IN MY IMAGE

A little philosophising on the coming high-tech revolution. Imaging is as old as evolution, according to Malcolm Goldfinch. Imaging is the reproduction of something in another form. Thus, DNA molecules are a form of imaging; animal cries, speech, writing, painting, photography, computing, video — all involve imaging, no matter how indirect the method may seem. Intrigued? . . . read on!

Malcolm Goldfinch

FOR INVESTMENT analysts in Wall Street, Gnomes in Zurich, Shogun of the Yen in Tokyo, the new 'buzz-word' is *imaging*. At last we appear to have a word that encompasses the whole field of endeavour which high-tech electronics is principally about. For humanity, imaging has been a fundamental achievement of gods. Just flip back the pages of the Bible to Genesis and find on the first page, "And God said, 'Let us make man in our image after our likeness . . . So god created man in his own image . . . male and female he created them'."

There is no denying, by either creationist or evolutionist, that imaging is the fundamental process for the continuation of life as we know it. Only recently has it been revealed to us that the reproduction of the cells that make up our body and all living matter, is the result of the chaining together in double helix form, simple substances, like nitrogen, phosphorus, sugar, to form the DNA molecule. DNA is the original imaging device that self-replicates. It is able to do this by following a long series of coded instructions contained in its helix; not unlike a computer tape. The human brain can now 'peek' and understand these chromosome codes, and we have the ability to 'poke' new bits into them by biological engineering, thus changing the very patterns of life. It seems incredible that we still use the term 'biological engineer' to describe someone bashing bits of code in and out of a chromosome helix in a DNA molecule. Perhaps 'imagineer' would be more acceptable.

That word 'imaging' has bugged me for

some months. It was used in the *Economist*, by a Polaroid press release, and an investment analyst in the US trying to de-tech and group together a lot of different high-tech goings on that seemed to turn out the same sausage. I thought it was valid and it looks more useful each day.

A hard look at imaging

If imaging is the critical basis of our present existence and progress it is worth examining in detail. It comes in two forms just like computer data, 'real-time/on-line' or 'time-shift'. Probably the first form of real-time or 'now' imaging, was a flipper, wing, arm, or leg, waggled in a certain manner when danger threatened. Possibly the original waggler died a squillion years ago, but those of the tribe who interpreted the waggle as danger and took off, survived to reproduce other wagglers, who also saw and imaged danger by a waggle. Those who did not were mostly eaten and never imaged themselves. It is not difficult to project evolutionary progress to show that grunts and screams allowed even more survivors than waggles did; language started to describe the threat, and so on. Speech was the only real-time imaging generally used on earth for some millenia, but with the imaging explosion in the 1800s there has been rapid progress; telegraph, telephone, radar, to an early-warning missile system — the current ultimate in real-time imaging!

Sadly, time-shift imaging only goes one way at present. Forward, it would revolutionise punting. Time-shift imaging probably

started when some form of life noticed that if you drank from a pool at a certain spot, you got pulled in by the nose and disappeared. Probably it was a humanoid that first started to sketch, with a stick burnt in a bushfire, a drawing of an alligator with a stick-figure in its mouth. This imaging of danger was stored in time until the carbon washed off the rock. Of course, those who drew and understood such danger signals spread their DNA codes through life much more than those who became a croc's dinner. If you also put this situation on a personal computer with a program for 'future' projection, you could find on the screen a high-resolution graphic of a couple watching an XXX blue-movie in colour and stereo-hi-fi sound, on a video. Odds are this couple will do more to spread their DNA code in future generations than a couple without a video and playing tiddlywinks. The tiddlywink players will probably be consumed by boredom before going to bed. Video is the present in ultimate in time-shift imaging.

In real-time imaging we have sounds, speech, signs from the body as primary sources. As long as you agree that a time-shift of less than a second is not a time-shift of mental significance, we may include telegraph, telephones, television and all their permutations which include computer data processing within this real-time span.

In the time-shift mode dancers image past behaviour; artists image past sight; singers, musicians and actors image past sounds; writers image past thought. This last time-▶



The phonograph was the first major advance in capturing the 'real' audio image.



TOWARDS A PERFECT IMAGE

Most of us in the business of bashing electrons on their way are likely to be considered part of this great imaging industry. Just how did it overtake us? It all started in the last century from a number of different directions.

The first reality imaging was called 'photography' (light-writing). Mande Daguerre and William Fox Talbot were the prominent pioneers. In the process a silvered copper plate was exposed in a

camera and was developed by depositing mercury fumes which amalgamated with exposed areas. Reflective and non-reflective areas against a dark background produced the photograph image.

We all know how later, others put photos together and we had the first, moving reality imaging, in time-shift, to store contemporary life; the reality, not a painting or a series of words. Such early imaging is now part of our priceless archives.



Daguerrotype stereo pair coloured images from 1853. They produced a lifelike stereo image when the case in which they were mounted was folded out.

The next step was telegraph imaging, then telephone imaging, both in real time. Then an historic time-shift by Thomas Edison, imaging of the voice, music and any sound. It was a purely mechanical device that is now electronic.

Photography is also halfway across the chemical river into the electronic world. Typewriters, telex copying machines, fax, data storage (digital-photographic), TV, video, music synthesis, hi-fi, PA, calculators, computers of all type.

All this may be a longshot from my Editor's request for a steer as to where video is going, but context in writing is somewhat similar to Einstein's fourth dimension. Without this it would be ridiculous for me to say what I wanted to at the beginning, "In the 1980s, humanity achieved its greatest emancipation through the perfection of imaging". As a rider I would add, "The advent of digital video is the final and most important link in the imaging chain". ●

shift, of writing, and to an extent drawing and dancing, is concerned with the time shifting of thought or as I prefer it *consciousness*, from the Latin 'consciuis', com = with + scire = to know.

My dictionary defines philosophy in part as, "The rational investigation of being, knowledge, and right conduct". Surely this is almost a synonym for the definition of 'consciousness', excluding "right conduct" (very contentious). All this is pertinent to imaging because it shows that writing as a means of imaging is a very blurred medium and the mental images from written codes will vary from person to person, yet *writing images* was all mankind had to shift consciousness through time. Consider how much better we would have understood the philosophy of, say Shakespeare, if he was now to read to us, passages from his plays with inflections of speech, gestures and facial expressions, using the time-shift to

perfection on any home video.

Perhaps now, or in the near future, we will have a brilliant bard who can do this for posterity. Once etched into a digital glass disk, such imaging would be there in archives for all time. For thousands of generations the full image of the human consciousness projected by this person would be handed down, crystal clear and with less room for interpretation to twist and blur real meanings.

The blurring of past time-shift, both in language and the symbols of writing, could have been a prime cause of human conflict, between tribe or nation. Where there is a grey area, the interpreters ply their trade. A study of history shows most wars were justified by a consciousness or philosophy which one tribe wished to impose on another, against their will.

Today computers can interpret languages with agreed definitions. Video can record

and convey the spirit and meaning of agreement. There should be little room for manipulators of past images of fact and philosophy.

How video imaging impacts

Imaging by video is of course much fuller than by writing. Words can evoke specific details and the rest of the picture is imagined through association or not at all. My grandson can say "I want it in video". Okay. Press a button, up comes, for example a horse walking. In the time it takes to read, "big horse walking" Grandson has now seen it all and in a flash, learnt what it really looked like; not his mental image with all errors and defects. He saw, not only a big horse walking, but also, that it was a rhone stallion, white sox on two fore and one hind leg, steaming because it has been galloping in a valley on a frosty morning and making a great whinnying noise.

This is the reality image. We now live in a whole new world of realism. You may like our dream world of the past but reality is here to stay. There is a million years or more between the first written imaging and this latest high-tech, reality-imaging in video.

If this is what imaging is about, then world financiers are right to regard most electronics based industries as part of this new wider field and want to invest and participate in the action. We technocrats may have missed the mainframe because we were looking at the chips, but suddenly we find ourselves in the new world of reality; be it real-time or time-shift.

One stop imaging

For years we have had vacuums to clean, washing machines to wash, automobiles for mobiling, but we have had to have a large number of devices to do our imaging. The camera, phonograph, radio, TV, hi-fi, tape/cassette recorder-player, copying machine, microfiche . . . If the people in these industries could now see themselves as all part of the faculty of imaging, and instead of working in hundreds of different directions they work towards providing the best common means of imaging, then this new era will really have arrived. The consumer could be happy with one imaging device for all these functions.

No matter what governments or multi national organisations plan for the marketplace to-day, the consumer is dictating, worldwide, what they will and will not accept. There has been a large number of ill conceived products foisted on consumers with the technological explosion of our age. Many have been caught with junk machines of a type or a format for which there is no film, tape, cassette, or parts and technology.

Quadraphonic sound was the first megabuck disaster and there are several consumer-dictated disasters of great magni-



We've moved

Before you reach for the phone to call Philips Elcoma, note that the Sydney number has changed. Our Head Office and warehouse are now located at 11 Waltham Street, Artarmon N.S.W. 2064.

Philips continue a quality tradition. With over 50 years of experience in the Australian electronics industry, Philips take another step to improve their customer service. The move to new

commercial premises for our Head Office and warehouse provided the opportunity to introduce better services. Note the change right now, so that next time you're looking for Philips quality electronic components you'll have our number right at your finger tips.

OUR NEW SYDNEY NO: (02) 439 3322

Interstate Offices:
 Melbourne: (03) 542 3333
 Brisbane: (07) 44 1091
 Adelaide: (08) 243 0155
 Perth: (09) 277 4199

We make electronics in Australia



Electronic Components & Materials

PHILIPS

WORKS 511

WHAT HAS MORE COMPUTER POWER THAN MANY LARGE OFFICES AND FLIES AT MACH 2?



The F/A 18 Hornet tactical fighter has more on-board computer power than many large office installations.

The ground facilities to back up this phenomenal aircraft are truly staggering.

Communications, over-the-horizon radar and the computerised avionics fault tree analyser.

To keep it flying as it should we need technically minded young men and women to train as Electronics Technicians.

If you have successfully completed at least year 10 with passes in English, Maths and Science

(physics content) and you would like to have a full-time career working with the very latest in aviation technology, contact us now.

If you are an Australian citizen (or eligible to become one), aged 17-34, telephone your nearest Air Force Careers Adviser on: Sydney (02) 219 5555, Newcastle (049) 26 3011, Wollongong (042) 28 1855, Parramatta (02) 635 1511, Canberra (062) 82 2333, Melbourne (03) 697 9755, Geelong (052) 21 1588, Brisbane (07) 226 2626, Townsville (077) 72 4566, Adelaide (08) 212 1455, Perth (09) 325 6222, Hobart (002) 34 7077, Launceston (003) 31 1005, or write to Box XYZ in your capital city.

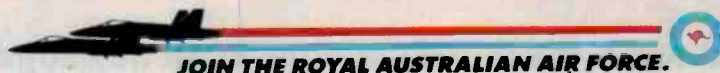

JOIN THE ROYAL AUSTRALIAN AIR FORCE.

Microbee HACKER'S HANDBOOK

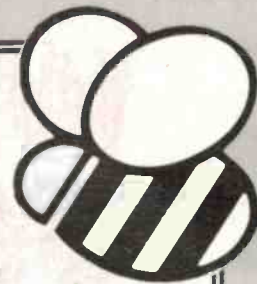

The Microbee Hackers Handbook will tell you how to:

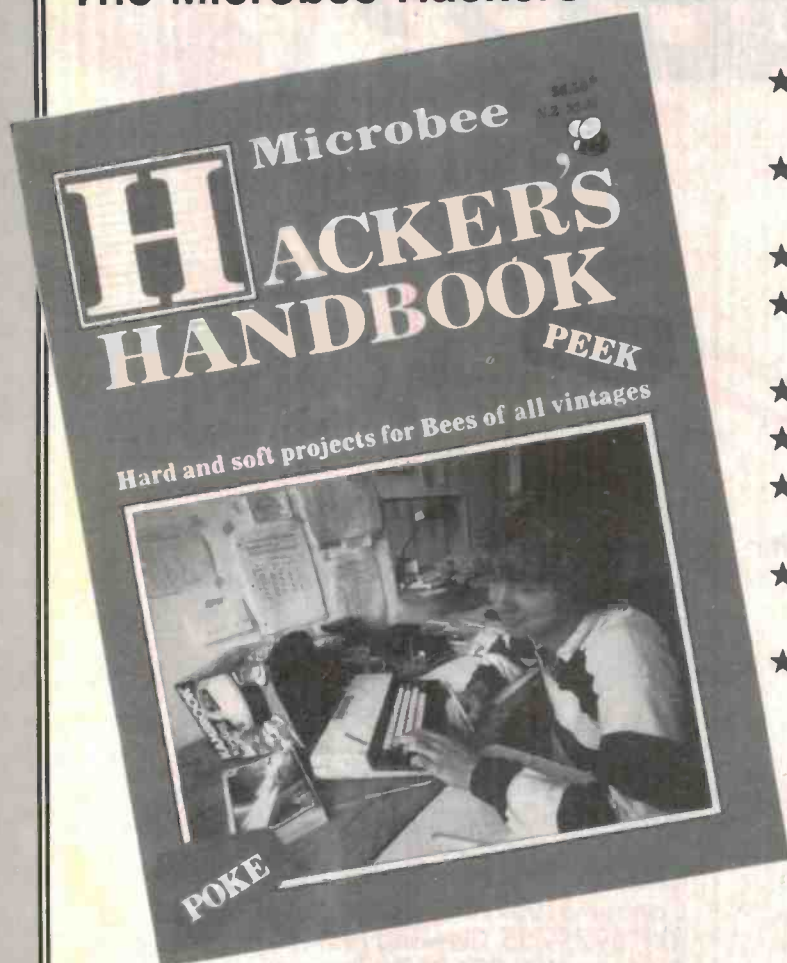

- ★ get more from the Bee's graphics capabilities,
- ★ set up for telecommunications on the Bee,
- ★ play music on the Bee,
- ★ build a joystick and a light pen for the Bee,
- ★ get hard copy — cheaply,
- ★ expand your 16K Bee to 32K,
- ★ make the Bee a better games machine,
- ★ turn your Bee into a facsimile decoder,
- ★ solve equations on the Bee
... and much more!

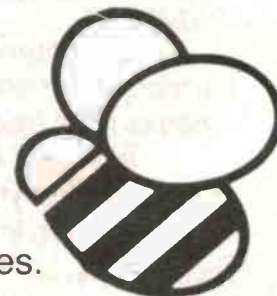

From the publishers of 'ETI' and 'Your Computer' magazines.

We've also included listings of the Bee's BASIC scratch area and machine language locations — to make the Hacker's pursuits easier.

For sociable Hackers there are the contact addresses and phone numbers of all known Microbee user groups.

\$6.50 Aust. (\$6.95 NZ) at your local newsagent.

SIGHT AND SOUND

tude, either taking place or likely to, in video/tape, video/disc, video/cameras, film/camera's and perhaps most of all in computers. Consumer dissatisfaction has resulted from a lack of awareness by some manufacturers as to where all this new technology is heading. Consumers are not going on a trip to anywhere.

Specifications for imaging centre

The vision I see for the consumer in the immediate future, is a home imaging centre using a sophisticated dual, digital-disk system, with a disk size similar to the 5¼-inch, capable of multi-megabyte digital storage and quick retrieval. It will have disk to disk copying and interchangeable drives also chainable to extra drives, and all with common inputs and outputs.

The home disk library will contain all the family still and video pictures, like a photo album, music, records or documents recorded on videocamera or fax, computer programs and data files. An analogue to digital, and reverse converter will be part of the system to interface with the telephone and or optic line. It will answer and image calls or give stored messages from voice recognition names to correct callers via computer control. The computer will be on line and in concurrency with the imaging centre at all times to take and send electronic mail and advise daily of appointments and birthdays.

All orders, receipts, income costs and expenses will be fed in and compiled into budgeted accounts and cash positions on line. All old analogue material will be digitally converted and imaged to disk for access as required. An optic cable with ports in every room will allow infrared remote control of the imaging centre from any convenient location, as well as the use of portable TV/computer hi-resolution colour monitors with infrared coupling to the fibre optic daisy-chain.

Hi-fi audio will be located with the imaging centre and remotely operated. Portable speakers will sense infrared digital audio input, from the fibre optic chain, and incorporate Carver type, high-power low-mass mini-amps.

Good news for the cleaners is no wire trails around the room. A powerpoint connection to monitor-TV and speaker-monitor will be all that is required. The computer will be controlled by an IBM-PC Junior type infrared keyboard. It is not a dream; all this exists now. Making it in lots of 100 000+ will correct the price.

Examples of use

Taking the vision further to using this imaging centre requires just a little 'imagination'.

Wanting hi-fi? Just select music from the computer databank by cursor or mouse from menu. Retrieve the imaging disks listed by computer, insert and wait for the transfer of tracks then remove from the im-

aging unit on computer instructions. Program now on disk 2. Return music disks to the library. Wheel speakers to the favoured location for listening, point infrared sensors to chain port, plug in speakers to any powerpoint, use controller to start selected program and continue control. Switch to FM/AM as desired.

Video? Repeat the process as for hi-fi and add portable video-monitor between speakers or wherever convenient. Replay selected discs for family or commercial video programs, family photo album, stored documents, select TV channels, optic cable programs, TeleText, etc.

Or perhaps portable video: use a normal camcorder such as the JVC GR-CJ and/or videocamera/VCR combination to shoot scenes and return to imaging centre and edit while replaying to imaging disk through analogue/digital interface.

The home computer to be used with the imaging centre would have memory in the order of 0.5 to one megabyte, always on line and loaded with a housekeeping program for home function, timing, reminding, phone messaging, electronic mail, database interrogation. Just program the menu and transfer control as described for hi-fi and video. All memory data would be saved to imaging disk and in a later housekeeping session would be transferred manually under computer instruction to correct library disks. Keyboard or other input peripheral sessions could be carried out in any location on the infrared optical chain where a keyboard and monitor are located. With multi-monitors concurrent computer games and keyboard operation would be possible without inhibiting housekeeping computing.

Conclusion

This futuristic home situation may sound as though it is for the very well-heeled. Think back five years. Only the very well-heeled were supposed to have a personal computer that could word process and print an acceptable letter, as well as play games. The idea of having a central imaging with one, two or more chained disk units that are made to a world standard and replace the plethora of imaging devices of different types we are using to-day, will rationalise the interchange of imaging as well as make a dramatic cost reduction.

Like hire-purchase deals it will be possible to start with only the optical chain around the home and add the imaging and peripherals as the finances allow. For the time being existing turntables, cassette decks, compact discs, VCRs, video disks, as well as computer DOS will be required to build up the imaging centre disk library. Amplifiers, TV or monitors and speakers will go on forever, but gradually order will come out of the present incompatible and duplicated chaos. The revolt against spaghetti-like tangles of wires, spread all over the carpets and shelves will at last be put down; or will it?

PINS, STAKES AND CONTACTS

Many different styles available to suit all PCB applications. Standard plating is silver or tin. But specialized plating can be obtained for volume users.

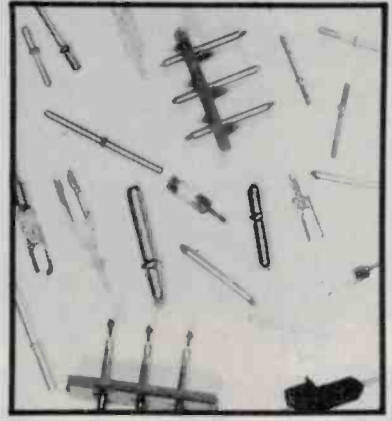

Available from:

SWANN ELECTRONICS INTERNATIONAL
PTY. LTD.

Melbourne (03) 544 3033
Sydney (02) 807 1944
N.Z. (9) 444 3620

IBM COMPATIBLE MICROCOMPUTER



IBM is a trademark of IBM.

MAIN PCB:	\$756.72 (plus tax)
<ul style="list-style-type: none"> • 256k RAM. • Disc cont. • Video cont. • Two RS232 ports. • 1 printer port (Centronics). 	
KEY BOARD:	\$94.58 (plus tax)
<ul style="list-style-type: none"> • Separate cursor port. • Cap lock and num lock. • Separate function keys 	
POWER SUPPLY:	\$151.34 (plus tax)
• 5V 10AMP • 12V 5V • Intergration • Metal enclosure	
CASE:	\$101.86 (plus tax)
• Metal-RFI shielding • Full mounting brackets for DD	
RGB COLOUR CARD:	\$295.00 (plus tax)
TOTAL PRICE:	\$1399.50
(Plus sales tax - 20% - if applicable.)	

energy CONTROL

Distributors for:
Rockwell

73 Eric St. Goodna, 4300, Qld, Australia.
P.O. BOX 6502, GOODNA, QUEENSLAND, AUSTRALIA, 4300.
TELEPHONE: (07) 288-2455/TELEX: AA 43778 ENECOM.
ORDERS PHONE: 008-777 147

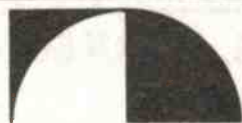

Nakamichi BX-300

Discrete Head Cassette Deck

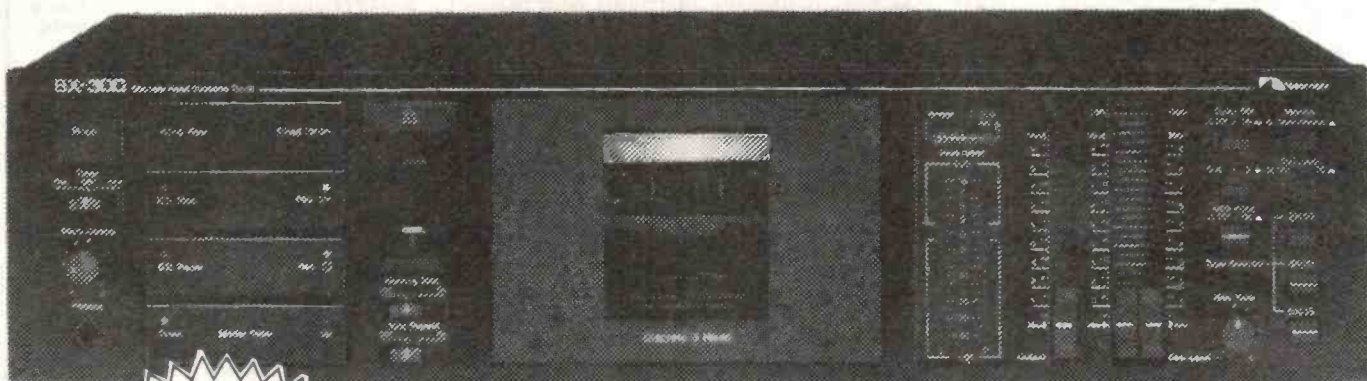

**3
HEADS**

Available
in black
only

\$899

OTHER FEATURES:

● ASYMMETRICAL DUAL-CAPSTAN DIFFUSED-RESONANCE SYSTEM ● HIGH-PRECISION BRUSHLESS, SLOTLESS, CORELESS DD CAPSTAN MOTOR ● NEWLY DESIGNED SUPER LOW DISTORTION AMPLIFIERS ● DUAL-SPEED MASTER FADER ● AUTO REPEAT ● BIAS FINE TUNING ● PITCH CONTROL ● DOLBY B/C NOISE REDUCTION ● WIDE-RANGE PEAK-RESPONDING LED LEVEL METERS (-40 to +10 dB) ● 4-DIGIT LED TAPE COUNTER ● REC MUTE ● MEMORY STOP ● MPX FILTER SWITCH ● SLACK-TAPE TAKEUP ● REMOTE CONTROL CAPABILITY WITH OPTIONAL REMOTE CONTROL UNIT ● FREQUENCY RESPONSE 20Hz-20,000Hz +3dB.

Nakamichi Sound—Pure and Simple

MAIL ORDER: Send cheque or phone through Bankcard, VISA or Mastercard Numbers and we will deliver anywhere in Australia free of charge.



Now there is no competition....

The world of Hi Fi awaits you at Len Wallis Audio.

SHOWROOM AND SOUND LOUNGES.

Len Wallis Audio

WHEN YOU'RE SERIOUS ABOUT HI FI.

Shop 9, The Village, 43-45 Burns Bay Road, Lane Cove.

Phone 427 1204, 427 1205 for bookings, or drop in.

OPEN ALL DAY SATURDAY

Micrographics breakthrough from WA

About five years ago Perth businessman Gene Kostecki found himself with a problem more of us should have. He had a bundle of money, and nowhere to put it.

The traditional answer to his problem among Australian businessmen is to put the money in real estate, or to buy a smart accountant and put it at the bottom of the harbour. But Kostecki wanted to do something useful with his money. So he joined together with another businessman of similar mind called George Brown. Two bundles of money looking for a good idea.

They found their idea in the person of Siegmund Raith, an electronics engineer with an interest in archival systems. Briefly, the situation he faced was that we live in the information age. It's an age when the accepted wisdom is that more information is necessarily better.

The problem is just this: how do you know what's available and where it is? Also, how do you store it and how do you get at it? Anyone who has been inside a decent sized library, especially a library orientated to research work, will understand what a problem this is.

The solution, in use for many years now, is microfiche or 'fiche' (pronounced 'fish'). A fiche is a small transparency, just like a photographic slide only bigger. Material can be photo-

graphed and then accessed by retrieving the slide and using a projecting viewer called a 'reader'. It's small, dirt cheap, easy to store, easy to use and given reasonable handling, lasts a long time.

The methods used to make and store microfiche were worked out about thirty years ago, and nothing much has changed since. Raith's idea was to take the whole microfiche system and apply modern computer techniques to it.

Four years and a million dollars later Raith and his co-workers stepped out of the laboratory with the fruits of their labours. The result was a camera with better resolution and greater flexibility than any other on the market.

At the centre of the Eagle Eye is a 6809 microprocessor. This controls the display, keyboard, servo motors and memories that give the camera some of its unique features. It gives precise positioning of the head (in the order of micrometres) to allow reductions from 1/8 to 1/36 in size. It also controls the positioning of the film, which uses a special vacuum system to align it precisely.

The result of positioning the optical path so precisely (2.5 μm overall) is optical resolution significantly better than any other camera available. According to independent assessments, the Eagle Eye can resolve 220 lines per millimetre with black and white film, and 180 lines per millimetre with colour.

The camera can intermix large maps or drawings with items down to postcard size. The infinitely variable shutter constantly adapts to conditions of illumination and glare to ensure uniform exposure.

The 6809 also controls an interface which allows electronic titling via a fibre optic link. It also controls data transfer between the camera and an external computer system. This allows documents to be titled by computer, then recorded and stored automatically. The information can thus be used to form a data base from which information can be recalled at will.

The question arises: why use micrographics at all, why not just store information on disc or some other electromagnetic medium, where it could be directly accessed by computer? The answer is just one of cost. A

single fiche contains some 10-15 gigabytes of information, at a cost of less than a postage stamp. And it can be used for maps and other graphic displays that are very difficult to digitise.

Armed with their lovely new camera, Browne and Kostecki headed off to the USA to try and drum up some sales. Before they left they approached the Department of Trade, which lined up various meetings for them. Each of these led to other contacts. Eventually they stuck the mother lode. The giant aerospace company, McDonnell Douglas, looking for some local offsets to set against the F-18 fighter program with the RAAF, agreed to act as marketing agent in the US.

With an assured market in the US and expressions of interest from Asia and Europe, Kostecki and Browne have decided to expand the operation from a six person R & D operation into a proper assembly line to turn out about 250 cameras a year. Cost? According to Gene Kostecki you won't get much change from \$100 000. Sounds like the start of a healthy business enterprise!

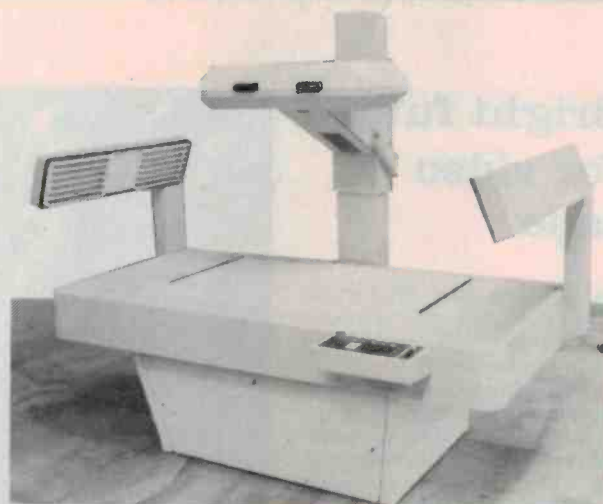

Topline BASF tape

BASF has released its new Chrome audio tape technology as the Chromdioxid Maxima II.

It combines ultra-fine Chromium Dioxide tape with a high precision cassette housing. According to BASF, the gold-labelled audio cassette performs better than the industry standard IEC II reference tape.

It conforms to the reference in sensitivity and operating point, but excels in frequency response from 8 kHz, increasing the brilliance of the reproduction and leading to a higher sound transparency. The Maxima technology also balances possible errors in the cassette recorder, such as slightly worn recording heads.

Maxima II's new patented cassette housing benefits from BASF's experience in plastics research and development.

In traditional cassette housings steel pins and axles are used to guide the tape and any deviation — as small as one fifth of one degree from the vertical — affects the tape path resulting in audibly muffled treble sounds.

But BASF's Maxima II employs the latest technology to mould plastic axles and pins with the housing to guarantee optimum vertical alignment and tape-to-head contact.

For more information contact BASF, 55 Flemington Rd, North Melbourne Vic 3001.

Bright future for video tape

Australians have the highest consumption of videotapes per head of population of any country in the world.

That makes it one of the most important countries in the world to Matsushita, the manufacturers of National videotape and one of the largest tape manufacturers.

In fact the General Manager of Matsushita's Export Department, Mr Mark Urakawa, visited Australia recently to discuss Australian requirements in bulk tape sales with his Australian agents, the Video Systems Division of GEC Australia Limited.

While here he made a few predictions about the future of videotape, and came up with a warning to technology buffs.

"Development of the 1/2" videotape technology still has some way to go," he said during a visit to one of Australia's major tape duplication houses, The Duplication Centre in Sydney.

"We are gradually increasing the density of magnetic particles of National tapes to improve picture quality."

Mr Urakawa said videotape sales in Australia were already booming, with Australians



showing the highest per capita consumption of videotapes of any country in the world.

"That is likely to rise dramatically once VHS hi-fi videotapes become available," he said.

He forecast that videotapes would dominate the home market for at least the next decade or two.

"Videodiscs, which are often talked about as the replacement for videotapes, just haven't been developed to a stage where they can be used commercially."

Discs will have their uses, such as data storage, but they will not replace videotapes any more than audio discs have

replaced audio tapes.

Before the advent of videodiscs, we'll see the development of high-density recording tapes to improve picture and sound quality.

And we'll also see the arrival of metal evaporated tapes with a plastic mirror surface to further improve the quality.

Much of the expansion of the market — and certainly in Australia — is going to be caused by the advent of hi-fi video. That has enthused Gordon Richmond, Managing Director of The Duplication Centre, who says that music video-cassettes will be one of the most popular

units in the coming 12 months.

"Hi-fi music is already sparking a demand among consumers that will change the market," he said. "It will mean that our tape sales will go beyond the libraries and will encompass the home market. That will eventually mean the development of catalogue sales to the consumer."

Hi-fi music video is completely different to all our previous experiences. It can be retailed at a reasonable price using the highest-quality reproduction available anywhere in the world," he said.

Low cost CD player

Marantz has fired a new shot in the CD player price war, with the release of this under-\$500 model. Called the CD44, it

features a rugged zinc diecast chassis for extended trouble-free operation.

Other features include ultra-

smooth motor powered front loading, repeat and pause function and programming for playing up to 20 tracks in any desired

order. Tracks can be skipped quickly both forwards and backwards, using the player's fast forward and reverse functions.

The CD44 has a multi-function digital display which can indicate total playing time, elapsed playing time, number of tracks on the disc, the track currently being played, or the programmed track numbers. Internally the player also features digital filtering, which Marantz claims provides improved sound quality.

Finished in black satin, the CD44 is a compact 320 mm wide. It is currently selling for \$499. For further information contact Marantz (Australia) Pty Ltd, 19 Chard Road, Brookvale NSW 2100. (02) 939-1900.





Sound facts in detail.

Ortofon have always dedicated themselves to pursuing the world's finest sound reproduction.

So when they discovered that the existing moving magnetic systems missed much of the sound detail, they did something about it.

They designed, developed and patented a new cartridge principle that could pick up as much detail as possible, accurately, from the record groove.

(Of course, as one of the recognized world leaders in sound reproduction, Ortofon were well-qualified in this area.)

They called it the VMS Principle.

The VMS Principle (Variable Magnetic Shunt) utilizes a light tubular armature of magnetic conducting material.

This is attached to the cantilever and encircled by a powerful ring magnet. When the cantilever moves the armature closer to the ring magnet, the armature short-circuits part of the magnetic field, generating a voltage in the coils.

And the result is an increased high frequency tracking ability, low distortion and superb

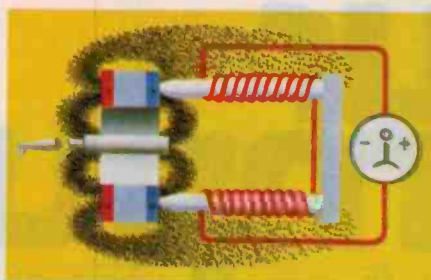

Symmetrical flux fields with the armature in the central (neutral) position. These flux fields emanate from the magnet positioned in front of the pole pins. As the fields are in balance, there are no changes in flux around and inside the coils. Therefore, no voltage is generated.

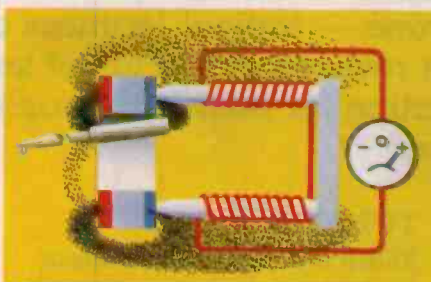

When the cantilever moves, the armature is brought closer to the ring magnet and acts as a shunt, short-circuiting part of the magnetic field. As a result, the flux field in front of the pole pins varies, and a voltage is generated in the coils.

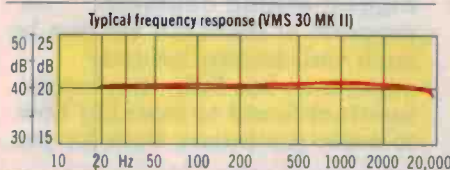

Technical data	VMS 30 MK II
Weight	5 g
Type of stylus	Fine Line
Equivalent stylus tip mass	0.45 mg
Frequency response	20-20,000 Hz
Output voltage at 1000 Hz per 5 cm/sec.	5 mV
Channel separation at 1000 Hz	27 dB
Channel balance at 1000 Hz	2 dB
Compliance static, vertical	28 µm/mN
Compliance dynamic, lateral (10 Hz)	22 µm/mN
Recommended tracking force	13 mN (1.3 g)
Tracking force range	10-16 mN (1.0-1.6 g)
Tracking ability at 315 Hz lateral	90 µm
Vertical tracking angle	20°
FIM distortion	1% (13 mN)
DC resistance	800 ohm
Inductance	600 mH
Recommended load resistance	47 kohm
Recommended load capacitance	400 pF

transient reproduction – right down to the very last detail.

As if that wasn't enough, the VMS also reduced sensitivity to hum pick-up and minimized distortion and non-linearity in the magnetic system.

Presumably, the cost of an Ortofon VMS Magnetic Cartridge would be high.

Surprisingly, it's not. In fact, it's especially affordable.

Check the facts on the VMS 10E MK II, 20E MK II and 30 MK II at your hi-fi or Ortofon dealer.

And while you're there, find out how to home-test your stereo equipment with the Ortofon Pick-up Test Record.

It's another sound fact in detail.

Distributed by Vanfi (Aust.) Pty. Ltd.

Melbourne: 297 City Road, South Melbourne, Vic. 3205. Tel. 690 6200.

Sydney: 283 Alfred Street, North Sydney, N.S.W. 2060. Tel. 929 0293.

ortofon
accuracy in sound

Do computers play any part in your life?

If they do — or if you just want to find out about them — don't miss each month's issue of



your computer

MAGAZINE

FOR BUSINESS AND PLEASURE

A magazine for all computer users and enthusiasts, **YOUR COMPUTER** has something for everyone — topical features on all aspects of the computing world, expert reviews of the latest software and hardware, up-to-the-minute information for business people, and even games and advice for hobbyists.

NEWS

YOUR COMPUTER brings you all that's interesting, innovative and inventive in the microcomputing world — news of products, plans and politics to keep you up-to-date with what's going on in this fast-moving industry.

REVIEWS

The latest machines and software from all the computer manufacturers are reviewed each month in **YOUR COMPUTER**. Keep informed about what's available, and use our reviews to help you assess which products are right for you.

TUTORIALS

YOUR COMPUTER's tutorials include regular series on such popular subjects as the BASIC programming language and dBase II, probably the biggest-selling database program of them all. Written by such well-known industry experts as Les Bell, they're an invaluable aid to learning how to make computers work for you.

PROGRAMS

YOUR COMPUTER regularly publishes all kinds of programs written by both professional programmers and readers, and ranging from games to business uses, utilities to additions and alterations to well-known programs.

All **YOUR COMPUTER's** articles are written in everyday English, not computer jargon, so even if you're a beginner there's something for you in every issue. And our regular columns on all the popular brands of microcomputers are packed with enough information to get any newcomer straight into the exciting world of computing.

At \$2.95 — less if you take out a subscription — **YOUR COMPUTER** is going to cost you a lot less than its overseas rivals — and provide you with the latest information on the computer scene in Australia at the same time. Look for it every month at your newsagent.

The cricket watcher's companion



Australian captain
Kim Hughes' exclusive series
preview
★★★★★

Colour posters of
the Australian and
West Indian stars
★★★★★

A complete
itinerary for the
season
★★★★★

Australian, West
Indian and Sri
Lankan player
profiles
★★★★★

World Series and
World
Championship
previews
★★★★★

**ON SALE
NOW!**

TNT ROADFAST

TOUR GUIDE

1984/85

\$1.95
\$2.25 NZ



by the editors of
AFRICA
Cricket

EXCLUSIVE
Kim Hughes'
Series Preview

You just can't be without it this summer!

SIEMENS

The better the drive, the smaller the disc

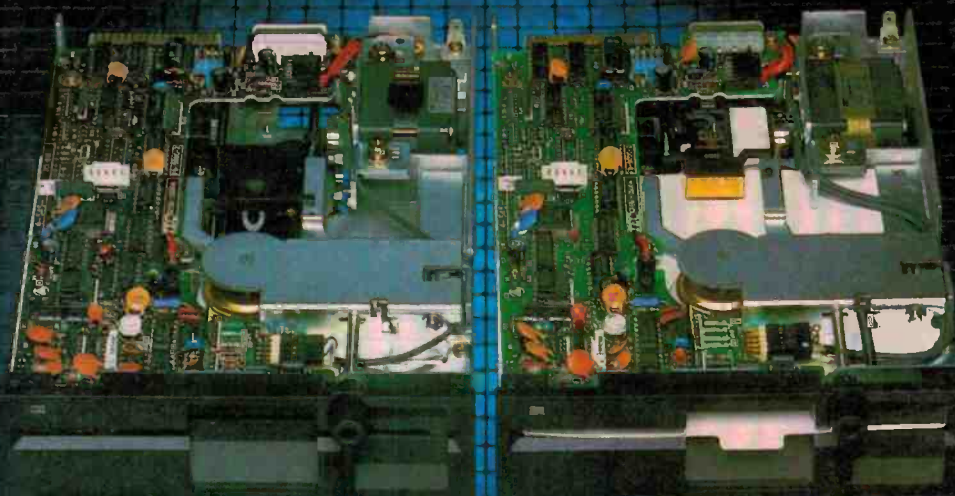

True half height 5 $\frac{1}{4}$ " floppy disc drives competitively priced from Siemens.

Designed for office electronics, business computers and OEM applications, this slim-line FB500 series has four versions with unformatted storage capacities from 250K to 1M bytes. Apart from compactness, these drives offer

fast access time by an advanced stepping motor and steel belt mechanism. The brushless direct drive DC motor is highly reliable and very quiet. The full range is now in stock together with Siemens relentless determination to provide complete service and technical assistance throughout Australia.

Siemens Ltd.

544 Church Street, Richmond, Vic.
Melbourne: 420 7318 Sydney: 436 8730
Brisbane: 369 9666 Perth: 362 0123

Distributors:

Auckland: Delphi Industries Limited. 567 258
Adelaide: R.G. Pank Pty. Ltd. 51 2411
Adelaide: Protronics Pty. Ltd. 212 3111
Brisbane: ECO Electronics. 376 5677
Melbourne: Promark Electronics Pty. Ltd. 878 4255
Perth: Reserve Electronics. 328 9755
Sydney: Promark Electronics Pty. Ltd. 439 6477

Siemens. The discs may be flexible, but never our standards.

QUALITY 'NO FRILLS' RECEIVER



THE BRAND NAME 'NAD' is not as well known in Australia as many other major manufacturers'. The reasons for this relate to the company's previous posture with respect to advertising and public relations in general. This attitude has perceptibly changed in the last year as a result of a shakeup in company management in the USA where the company's headquarters is located.

NAD is somewhat different from all of the other companies with which I am familiar in that it is owned by the distributing companies and dealers in the five continents where the products are sold, and while the company's attitude to public relations has

A modest, unobtrusive stereo receiver peeps out of the shop front window, retires into the lounge room corner. But under the test, the NAD 7155 shines. This receiver gives a performance worthy of much attention, with innovative extras and quality sound.

obviously changed in the last year, the basic design philosophy underlying its product design development and market has not. The company executives and dealers are very quick to state their attitudes on product design and performance and tell you that their aim is "to market the best possible product at the lowest possible price".

Your response to that statement, like mine, many will be "isn't that everybody's?". Well, yes it is, except that NAD believes implicitly that the correct path to achieving that philosophy lies in the deletion of unnecessary frills avoiding garish and expensive front panels and reducing the number of functional controls provided to the bare minimum.

This is aimed at not only keeping down

the cost, but more significantly in producing a simpler, more straightforward design which most purchasers really prefer in the end. NAD tells you that "this puts the emphasis on performance rather than on appearance".

Design and function

The 7155 'digital' stereo receiver does not immediately appear to be an exciting piece of equipment. Although it offers multiple features, some of these tend to be understated in terms of the factors that we would normally expect a manufacturer to stress in his literature. Because of this approach, the most exciting features tend to be the things it *doesn't do* rather than the things it *does do*.

NAD 7155 STEREO RECEIVER

Dimensions:	420 mm (wide) x 108 mm (high) x 380 mm (deep)
Weight:	9.18 kg
Manufactured:	NAD Electronics, Lincoln, Massachusetts, USA
Recommended Retail Price:	\$869

SOUND REVIEW

The frontal appearance of this receiver is the least assuming of any receiver I have yet reviewed. It is neither 'brassy bronze' nor 'flashy silver' but features a neutral flat grey front panel with white screen printed lettering. The main controls and displays are set out on two basic levels with relatively few controls in each.

On the upper level, centrally located, is a smoked escutcheon digital display panel behind which station frequencies may be seen, with clear plasma display designations for FM or AM. These are supplemented by a set of five rectangular light emitting diodes (LEDs) to indicate station signal strength and a neat pair of arrows to indicate that your carrier is off frequency and which flank a central rectangular LED; this illuminates when the receiver is correctly tuned to the carrier frequency.

To the right of this display are five push-buttons for selecting preset station frequencies and an entry button and a switch for selecting AM or FM. Above these controls are two small amber LEDs that indicate that an FM stereo station is being received and a SOFT CLIPPING indicator which shows that the soft clipping switch on the back panel has been activated. To the right of the display is a rocker bar SEARCH control that allows you to increase or decrease frequencies, and below which is a SEARCH MODE button which automatically sets the tuner into a scanning mode to search out station carriers rather than incrementally stepping the frequency control.

There are relatively few controls on the bottom row. On the left is the POWER/ON switch and the HEADPHONE socket. Besides these, there is a rotary speaker selection switch for 'A' system, 'B' system, OFF and 'A + B' system. To the right of these are a BASS control, a TREBLE control and a BASS EQUALISATION switch which boosts the frequencies below 60 Hz to compensate for drooping speaker low frequency response.

The next control is an INFRASONIC DEFEAT switch which disables the rumble filter roll-off characteristic, a standard feature of the input circuitry. This normal roll-off characteristic provides 13 dB of attenuation at 10 Hz. With the infrasonic defeat control activated, the low frequency attenuation is reduced to 2 dB at 10 Hz and less than 0.5 dB at 20 Hz.

A mono push button provides the ability to combine the two stereo channels, which is a function that would not often be required. The fourth control is a push button which disconnects the internal DYNAMIC SEPARATION circuit. This particular circuit selectively reduces the stereo separation at high frequencies in order to maintain a stereo signal when a weak incoming RF signal is inadequate for the maintenance of normal stereo listening quality.

One area where the functional controls seem to be more comprehensive than you might expect is in the area of functional recording and playback controls. In this

area the 7155 provides two completely separate switches by means of which the recording function and the listening function can be completely separated. The designations for each of these controls are precisely the same: CD/AUXiliary, PHONO, TUNER, OFF, TAPE 1, TAPE 2. This provides the wherewithal to record off one input, playback to another and then separately listen to a third.

Two other push buttons are provided labelled LOW LEVEL, which is another title for a mute switch, providing 20 dB of attenuation. The other switch is a LOUDNESS COMPENSATION control which activates a loudness equalisation curve boosting the low frequencies and high frequencies to compensate for the subjective physiological response to low level audible signals.

The last control provided is a circular volume control with a centrally located indented balance control offering one of the best ergonomic design features for this control function that I have yet seen.

The rear of the receiver is neat and functional with the connections, controls and switches laid out in two rows. In the upper row is an AM ferrite loop stick antenna which the designers have carefully labelled with the caution "THIS IS NOT A HANDLE"! Beside this are spring loaded terminal connections for an external AM antenna, a balanced 300 ohm FM antenna and ground connections for the AM antenna. Unlike many other receivers, this unit also incorporates a 75 ohm coaxial socket to facilitate direct connection of a properly wired FM antenna.

In the top centre of the back panel are eight clearly labelled colour coded universal terminals for connection to the loudspeakers. The bottom row of controls features a pair of phono-sockets with a switch for changing from moving coil to moving magnet and a separate switch for setting the parallel input capacitance to 100 pF, 200 pF and 300 pF. RCA coaxial sockets are provided for CD player/AUXiliary input. This is the first unit that I have seen which acknowledges the existence of CD players and goes to the trouble of ensuring that the input circuitry is specifically designed to cope with the CD signal levels and CD player dynamic range. The adjacent sockets are provided for connecting two separate tape recorders. The pre-amplifier outputs and amplifier inputs are externally linked by two simple linking bars so that you can take connections out of the pre-amplifier or feed them back into the main amplifier input should you require it.

Three other switches are provided for setting the output impedance for 8 ohms or 4 ohms, a switch for activating the soft clipping capability and the third an extremely useful, but little used, switch for bridging the inputs so as to be able to obtain twice the individual channel's power rating but only in the mono mode.

The inside of the amplifier is extremely well laid out with the front of the amplifier

containing two separate large printed circuit boards. These are mounted one above the other with the RF circuitry on the top board and the amplifier circuit located on the bottom board. The RF circuit board makes effective use of large scale integrated circuits for tuning and display functions, but most of the important tuning elements are still discrete transistors with clearly labelled circuit designations to assist maintenance, should it ever be required.

The power transformer is located at the extreme rear of the amplifier beside the large multi-finned heatsink which lies between a well perforated top and bottom panel. Behind this heatsink is a separate RF input stage pre-amplifier board to which the connections from the individual input terminals for both RF and audio frequency circuits are directed. This facilitates remote switching by means of mechanical linkages extending from the front panel. The designers have obviously gone to considerable trouble to ensure that the interaction and screening problems that many other receivers experience, are not duplicated in this particular receiver.

The construction of the chassis is well executed and rigid, incorporating a large area of perforated ventilation slots in the top cover to ensure that the unit is capable of providing proper cooling under almost any foreseeable situation — excluding the total obstruction of the air path. Even this however has been considered by the designers, there is a series of internal protection circuits backed up by circuit board fuses to provide two levels of defence in the event of overheating.

Test performance

The functional and objective assessments revealed that this is a superlative unit with basic characteristics that are in most respects better than many, if not most of, the competing receivers within the same price range. The frequency response of the amplifier is ruler flat from 20 Hz to 20 kHz and extends from 10.4 Hz to 53 kHz at the -3 dB points. The sensitivities and overload points of both the auxiliary inputs and cartridge inputs have been carefully designed and selected to cope with an extremely wide range of optional units which might be connected. The amplifier distortion levels are particularly low although not the lowest that we have seen.

Notwithstanding, this performance is as good as you could ask for and better than you can reasonably utilise in normal stereo listening. The IEC high frequency total difference frequency distortion figures are good, but not exceptional. The lowest distortion is achieved at approximately the 40 watt peak level where I would expect most serious listening to take place.

The soft clipping function which NAD has stressed as a feature of its amplifier design for the last five years, proved to be particularly interesting.

As a photo of the fast Fourier analysis re-▶

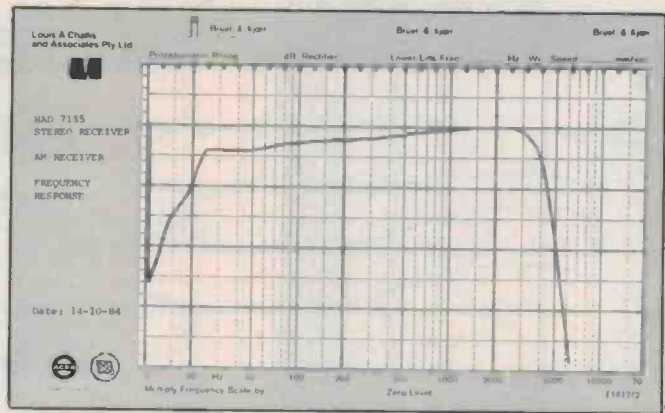
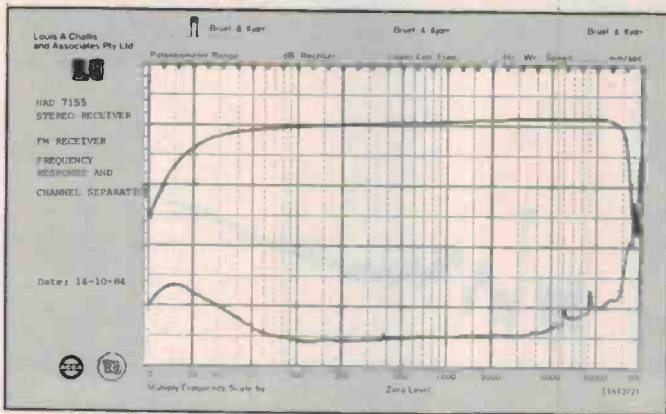

Our Ref: 4629A.219A/E140

MEASURED PERFORMANCE OF NAD MODEL 7155 RECEIVER

Serial No: 202313

FREQUENCY RESPONSE:

Tone Controls Centred

(-3dB re 1 Watt, 0.5V Input to Aux.)
 Left 10.4 Hz to 54.0 kHz
 Right 10.3 Hz to 53.0 kHz

SENSITIVITY:

	Left	Right
Aux. (for 1 Watt in 8 ohms)	19.5 mV	19.0 mV
Tape	10.5 mV	19.0 mV
Phono M/M	415 μV	410 μV
Phono M/C	32 μV	31 μV
Overload M/M	170 mV	165 mV
Overload M/C	17 mV	16.5 mV

OUTPUT IMPEDANCE: 95 milliohms (@ 1kHz)

HARMONIC DISTORTION:

(A) (At rated power of 55 Watts into ohms = 21 Volts)

	100Hz	1kHz	6.3kHz
2nd	-87.0	-96.5	-96.5
3rd	-78.0	-100.2	-88.8
4th	-111.7	-106.1	-96.8
5th	-94.9	-112.4	--
THD	0.013	0.0019	0.0034%

(B) (At 1 Watt into 8 ohms)

	100Hz	1kHz	6.3kHz
2nd	-97.2	-93	-91.7
3rd	-82.2	--	-91.9
4th	-107.5	--	--
5th	-104.4	--	--
THD	0.0079	0.0022	0.0034 %

TRANSIENT INTERMODULATION DISTORTION: Less than 0.1%

(3.15kHz square wave and 1.5kHz sine wave mixed 4:1)

NOISE AND HUM LEVELS:

(re 1 watt with 8 ohms) with volume control set for 1 watt output with 0.5V input (Aux.)	AUX.	-83.5	dB(Lin)	-87	dB(A)
3mV input (Phono M/M)	PHONO M/M	-57	dB(Lin)	-70	dB(A)
	PHONO M/C	-65	dB(Lin)	-71	dB(A)

MAXIMUM OUTPUT POWER AT CLIPPING POINT:

(IHF-A-202) (both channels driven) (20mS burst repeated at 500mS intervals)

	76.0	VP-P
	= 90.3	Watts
∴ Dynamic Headroom	= 2.15	dB (re 55 Watts)

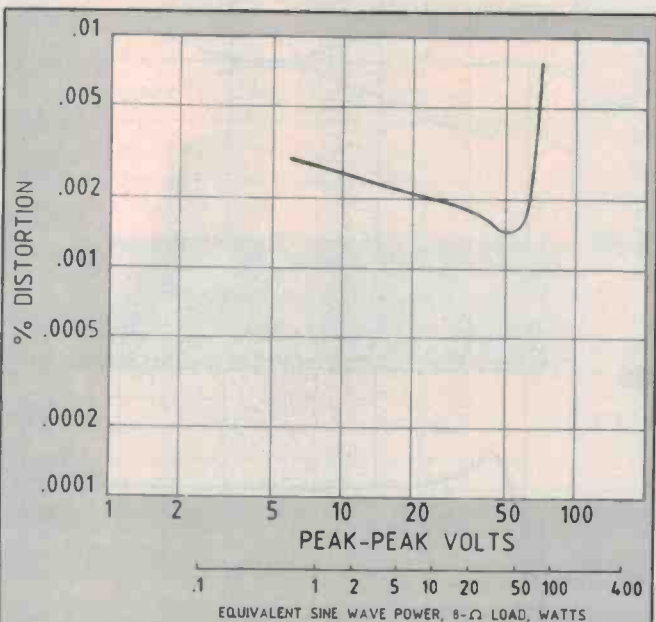

NAD 7155. IEC high frequency total difference frequency distortion.

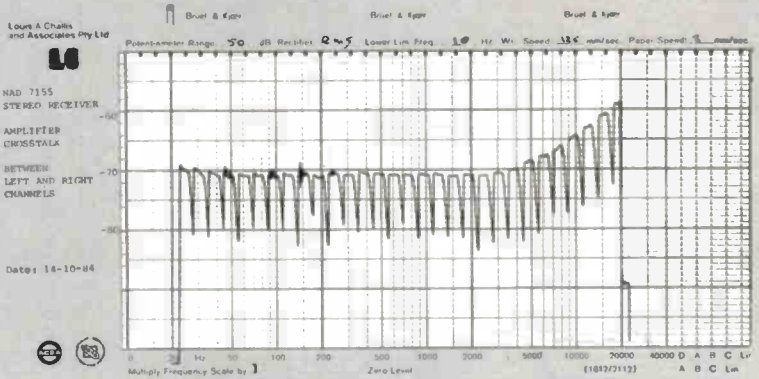
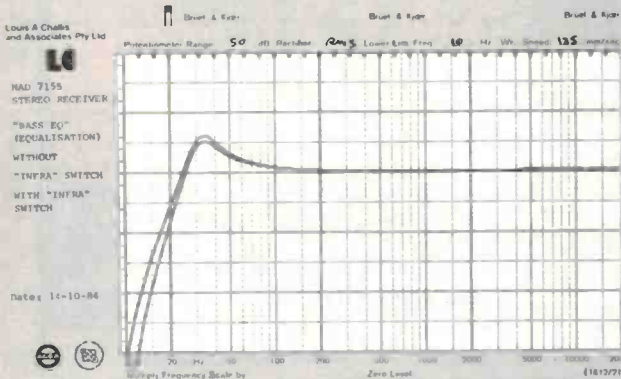
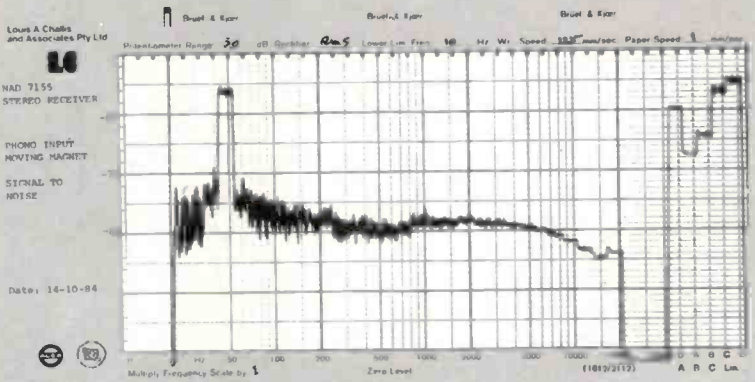
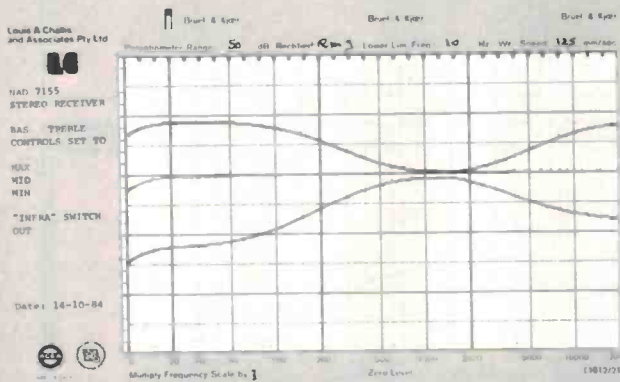
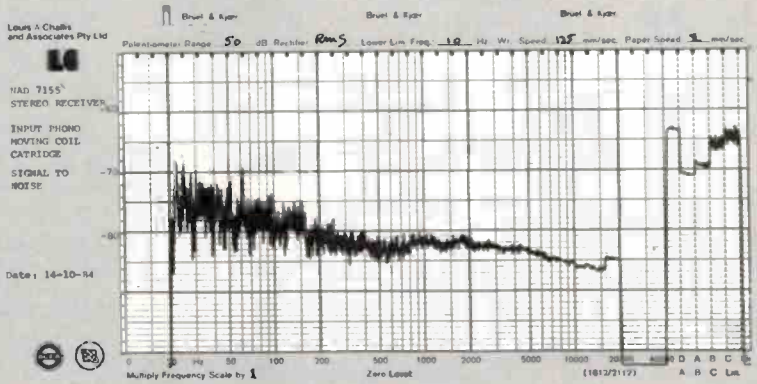
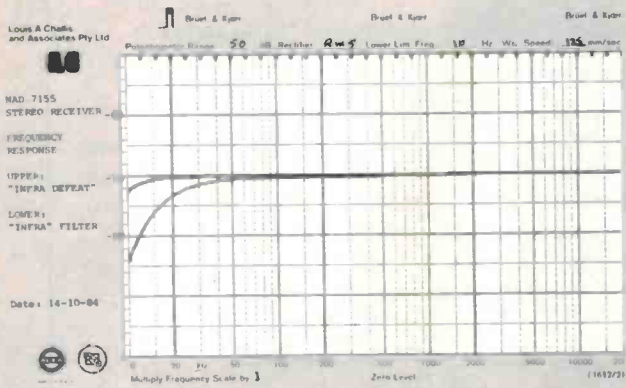
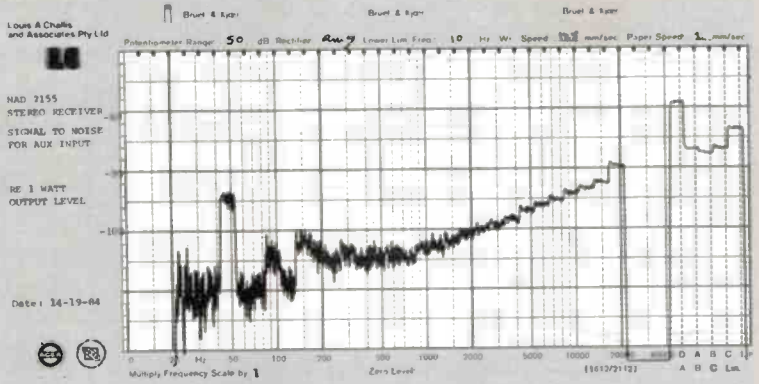
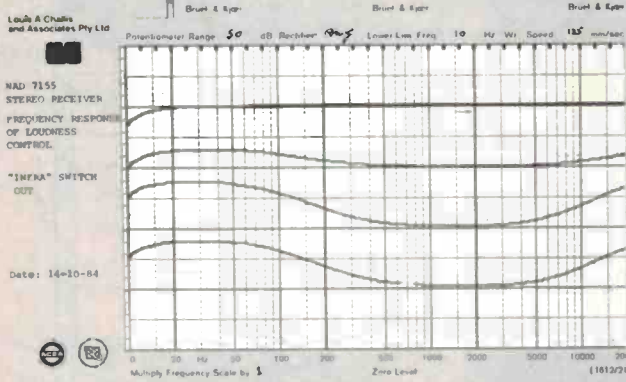

veals (see Figure 1) in the normal clipping mode the magnitude of even order harmonics is close to that produced by the odd order harmonics. This results in a subjectively disturbing sound and typifies the worst feature of amplifier clipping. In the soft clipping mode however, the even order harmonics are at least 25 dB lower than the odd order harmonics and even though the amplifier excursions may extend into the clipping region, the subjective impact is far less disturbing and the quality of sound is 'almost acceptable'.

It is interesting to note that a number of other manufacturers have recently picked up this concept and now include it with their latest generation of amplifiers.

The output impedance of the amplifier is 95 milliohms which is quite low and ensures that with reasonable speaker cables and even with low input impedance speakers, you are capable of transferring maximum power output.

The tone controls and base equalisation switch provide usable, complementary and effective boost and cut, although most people tend not to use tone controls to any great extent, particularly when the listening rooms are well designed or incorporate adequate amounts of soft furnishing and carpet.

The signal to noise ratio of the amplifier is particularly good achieving 87 dB(A) re the 1 watt output on the auxiliary input, 70 dB(A) re the phono moving magnet input and 71 dB(A) re the phono moving coil input. These figures ensure that the amplifier noise is always well below the source noise levels on any practical programme that you may listen to. The channel separation and cross-talk capabilities are extremely good, being better than 70 dB separation at frequencies up to 2 kHz and 60 dB separation at 20 kHz. The amplifier delivers a genuine 90 watts peak output into 8 ohms, 125 watts bridged into 8 ohms and has a single channel dynamic headroom of 2.15 dB above the rated power output. This falls a little short of the manufacturer's claimed 3 dB headroom capability.

NAD makes a number of claims regarding the superior performance characteristics

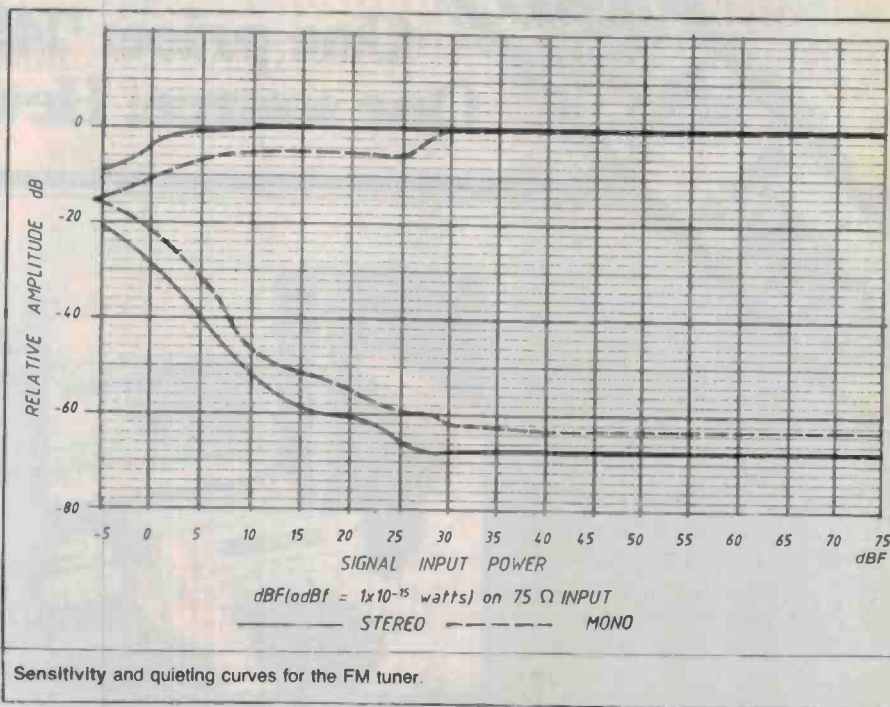

Sensitivity and quieting curves for the FM tuner.

of its tuner section which incorporates higher performance ceramic IF filters, optimised gains and losses for each IF stage and NAD's new dynamic separation circuit to reduce noise in weak FM stations by a happy match of conventional high blend circuitry and interchannel cross-feed at lower frequencies. These claims appear to be confirmed by our objective measurements which achieved better than 70 dB mono separation at 40 dB and higher and better than 62 dB channel separation at 30 dB and higher.

The maximum performance figures are greater than those shown on our graph which are limited by the signal generator rather than the receiver. The FM linearity is -3 dB from 22 Hz to 16 kHz and channel separation better than 35 dB from 100 Hz to 4 kHz. Even the AM performance is reasonably good, being 3 dB down at 70 Hz and 3.7 kHz and offering a better overall AM performance than most other receivers currently available.

The most outstanding feature of the two tuners is their sensitivity which no other receivers in their class has yet bettered.

The subjective performance of the NAD 7155 receiver is positively outstanding. I listened to it with a wide range of inputs including CD players (Sony CDP-101), cassette recorders (Nakamichi Dragon), record players (fitted with Shure V15-IV and Audio Technica AT30F cartridges) and I listened to speakers including B & W 802Es, KEF 104s, QUAD electrostatics and even Pioneer electrostatic headphones. The performance was positively exhilarating until I reached the power limit of the amplifier, which is typically around the 100 watt level into normal speakers and slightly

more into the KEF 104s.

On a few occasions when listening to other speakers with even lower efficiencies, I would have liked a little more power, but for the vast bulk of my listening the power handling capacity proved adequate. Whilst the performance was outstanding with CD players and record players, it was positively marvellous when connected up to provide the audio output from the two stereo VCRs (see November ETI).

With FM listening I was more than a little surprised when I found the receiver pulled in five local FM stations without any aerial attached and achieved maximum modulation sensitivity with only a simple folded dipole antenna lying on the floor. This sort of performance has not been achieved by any other receiver or tuner I've reviewed and is a measure of the sensitivity of the input circuitry used in the NAD 7155.

Highly commended

The selling price of the NAD 7155 does not reflect the 'no frills' concept; it is comparable with and in some cases higher than that from other manufacturers offering similar output powers from the amplifier stage. Nevertheless this receiver offers extremely good RF sensitivity which few other manufacturers can equal.

If I was to go out and select a receiver for myself I would be hard pressed to find a better unit. If you like simple 'no frills' concepts, then the NAD 7155 is most probably what you have been looking for. If you are looking for that type of subdued visual impression, combined with exceptional RF sensitivity, selectivity and particularly good audio amplification capability, then you need look no further. ●

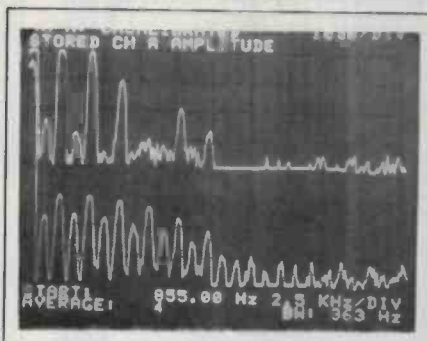

Figure 1. Fast Fourier analysis of amplifier in clipping. Upper trace with soft clipping switch activated. Lower trace normal clipping.

Now! \$1495*

**One style: fully loaded
One price: \$1495*
One source: Hewlett-Packard**

If putting a big dent in your instrumentation budget is not for you, the HP 3478A should prove ideal for your bench or system automatic measurements. For only \$1495* you get a fully loaded six function DMM with HP-IB—not just a starter unit you have to pay later to upgrade.



All the right features plus HP-IB.

You can measure dc volts, RMS ac volts, dc current, RMS ac current, and 2- and 4-wire ohms. Plus, the HP 3478A is a fully programmable HP-IB system instrument. You have the convenience of switchable front/rear terminals, scanner advance, and external trigger input. You can even automate the HP 3478A's built-in electronic "no pots" calibration.

Costs less to own.

When it comes to reliability, the HP 3478A is one of the best. Our field-proven reliability figures indicate over 50,000 hr MTBF (equal to 25 operational years)** So intensive is our attention to quality, from design right through production, that once you install your HP 3478A chances are you won't have to repair it or worry about it for the life of your system.

Call HP today.

For full details on the cost-cutting reliability leader HP 3478A DMM, fill in the business reply paid card coupon opposite or ring your nearest HP office listed: Melbourne: 895 2895; Adelaide: 272 5911; Perth: 383 2188; Brisbane: 30 4133; Canberra: 80 4244; Sydney: 888 4444; Auckland: 68 7159. ** For 2,000-hour years, based on warranty data and other statistical projections. * List price subject to change.

System DMMs...HP's the right decision



HP-IB: Not just IEEE-488, but the hardware, documentation and support that delivers the shortest path to a measurement system.



**HEWLETT
PACKARD**

LBV 6675 HEP 90399

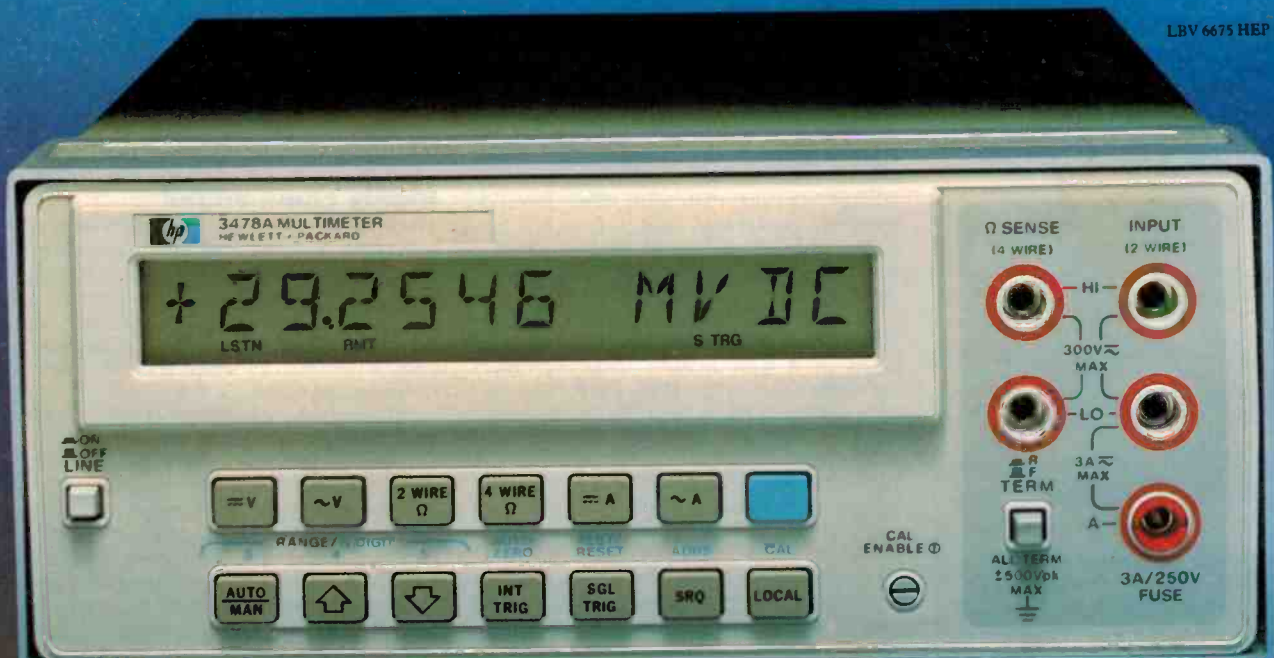

NOW PIONEER PUTS TWICE AS MUCH STEREO FUN IN YOUR CAR.

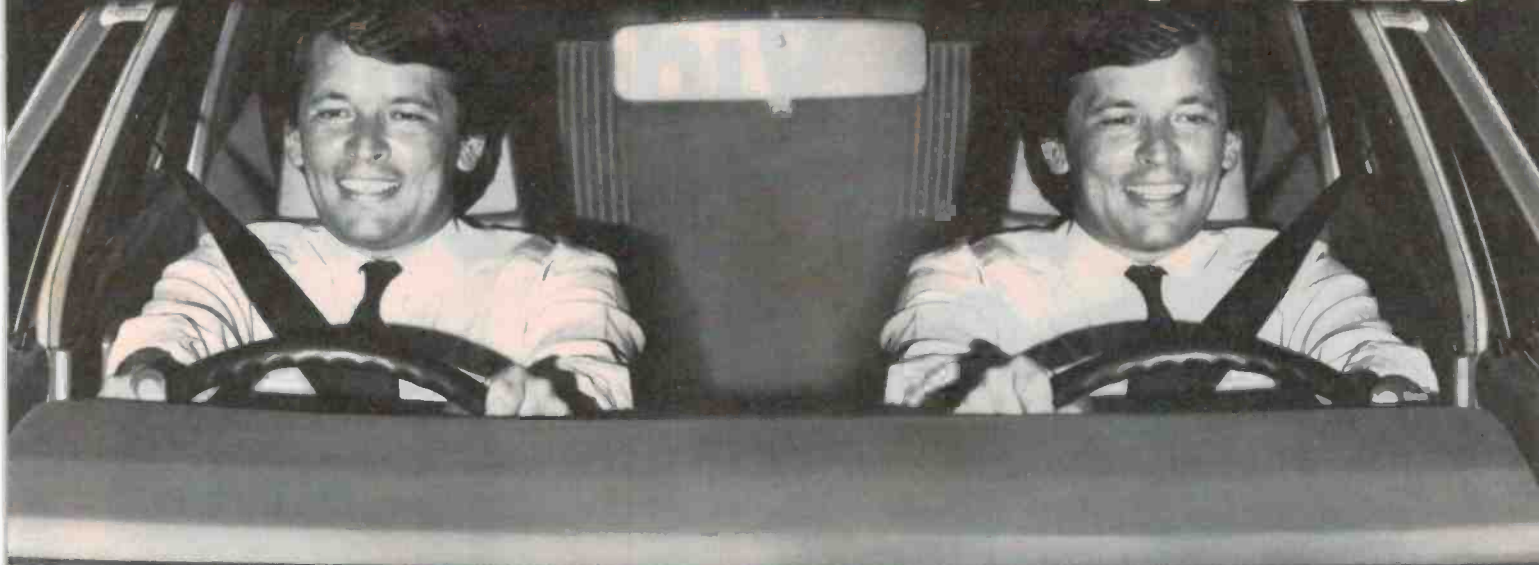

Now with AM Stereo here, Pioneer puts twice as much stereo fun in your car with the launch of the KEA 433AM Electronic Tune AM/FM stereo cassette player.

stations to the classics. From talk-back radio to sports broadcasts, everything will sound twice as good because it's in stereo.

And like all Pioneer products the advanced features of the KEA 433AM are equally brilliant.



PIONEER.FIRST IN AM STEREO.

Pioneer has always led the way in car stereo sound.

From designing the most advanced tuner/deck combinations, graphic boosters and power amps to building the widest range of speakers in Australia.

KEA 433AM lets you listen to the widest range of AM and FM stations in brilliant stereo sound.

From the top rock and roll

and seek, lock in fast forward and rewind, auto tape replay and metal tape facility to a built-in fader system for 4 speaker control.

You can own the Pioneer KEA 433AM stereo radio cassette for as little as \$349.* It's a small price to pay, to make everything you listen to in your car twice as much fun as before.

 **PIONEER®**
The power to move you.

* Rec. Retail Price

JVC's VideoMovie camcorder



— gladiator
in the
video
colosseum

Malcolm Goldfinch

FOUR YEARS ago on a winter's morning, I attended a gathering of the photographic industry and the opening feature was a very dark and underexposed, super-8 film of the beach at Nielsen Park in Sydney. A lovely young lady, horribly overexposed and probably goosepimpled in the winter chill, danced along the water's edge. In her wake came a hobbledy-hoy figure with an enormous video recorder around his neck, grasping in both hands a gigantic camera. The cord from camera to the recorder wound around his legs and he stumbled and fell while the nymph raced out of sight. Just then a neat figure with a small super-8 camera appeared, jogging nonchalantly past the fallen video man to catch up with Miss Goosepimples and shoot her down with a long burst of film. This scene came to mind when I first picked up the exciting new JVC camcorder, 'VideoMovie' at the Perth Consumer Electronics Show. That monstrous home-video system I saw on film had been reduced to a single, light piece of equipment which while not fitting into the palm of your hand, has a 'prosthetic' handgrip and it is easily held and operated single-handed.

The new VideoMovie GR-C1 weighs under 2.5 kg — a figure which includes battery for an hour, and a 30 minute cassette, yet it is only the size and weight of big racing binoculars. It incorporates a full video, record-playback system that will replay on any TV and also dub what it plays on to any VCR, Beta or VHS!

A review of the JVC GR-C1 video camera/recorder, released at the Perth Consumer Electronics Show last August. It's destined to be the first product to strike a blow to the popular Betamovie camera/recorder — the other combatant in the video colosseum.

Film and video, (chalk and cheese)

There is an enormous difference between film and video. The heavy video gear, hanging on the man on the beach equated with a camera with a sensitivity that would require film of some thousands of ASA degrees of speed, a colour and sound film processing laboratory, (in order to instantly process pictures) and a projector and screen, so the photographer could see the picture he had taken to check and correct it before leaving the subject. The videoman carried all of this in two packs, total weight say 10 kilos.

Nevertheless millions of consumer dollars worldwide have gone into video at the expense of photography. Sales of super-8 film gear to new users are just about nil. One point missed by the film people was that the video man's early morning beach scene would have been brightly exposed, not dim like the film man's. The film man did not know he was

underexposed until the film came back from processing. Lights to take good video on the other hand, are quite unnecessary today.

After the Perth CES show I caught up with the VideoMovie and made it part of my family for over a week. Women accepted it at once, welcoming it as a wanted, one-piece video, simple and light like the home camera. They could now handle a video to record the family 'golden moments'. Some women are great photographers for this reason. But some men (and women) with video knowledge, were inclined to react more energetically, and saw it as revolutionary.

The VideoMovie and others to follow will undoubtedly revolutionise what we have known as home photography, despite its price at approximately \$2500 recommended retail. Running costs, however, are minimal: no developing and printing charges. If the VideoMovie is a goer and first sales suggest it will be,

RF unit. This RF converter permits VideoMovie to be connected to most TV sets for playback . . .

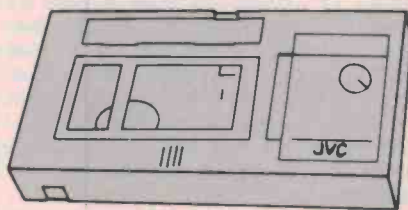

VHS cassette adaptor. The motorised version (C-P3/U) can hold a compact VHS-C cassette in a full size VHS cassette or cartridge for use on a standard VHS recorder.

VHS-C (compact-VHS) becomes a major world video format as an add-on to VHS, just as VCR video only succeeded because it was an add-on to the billions of TV sets and their TV stations already in the marketplace with the service technology already at hand.

VHS-C's video niche

It would be misleading to describe the VideoMovie without first outlining the entirely new technical environment introduced by sub-VHS format.

Although the Shogun of world video has at least decided on the new 8 mm format tape, JVC, always the revolutionary, launched the VHS-C (compact-VHS) format tape, now used in the VideoMovie, two years ago. The cassette (90 (w) x 60 (d) x 20 mm (h)) is roughly the size of a 20 pack of cigarettes and has a 30 minute (in PAL) supply of standard VHS tape inside. The small package is something I feel the industry has needed for years. As a past 9.5, 16 mm and super-8 film user I felt a three minute film was a long time; a three hour tape, ridiculous for portable video! You lose whole scenes and never find them again without long searches. A whole lot of neatly labelled 30 minute cassettes would suit most cine users. I can hear the question, "But what about my three or four hour timeshift of TV films?". Well, VHS-C is an add-on. It is not intended for timeshift of big programmes. If you accept that, then VHS-C becomes a great new cine medium.

The VideoMovie does not have a tuner/timer, or the docking facility of the first 8 mm portable videos announced by Kodak and Polaroid for delivery sometime in 1985. The term docking is adapted to video from spacetalk. It refers to a simple no-wires method of connection, to help the technically dyslectic to couple their portable VCR into the home TV and turn the portable into a home VCR with

tuner/timer. The logic of this escapes me as there is a reputed limit of about one hour for the maximum recording time for an 8 mm video camera. It is my belief that VHS-C has not gained worldwide popularity in the past for the same reason. It was considered a hopeless timeshift format. Until now, few saw it as a brilliant cine format: nothing to do with timeshift.

Oddly JVC's close associate, National, has failed to follow with hardware for VHS-C, where Sharp and Philips have. As far as I can ascertain, National has no immediate plans to do so, but during 1985 will announce a full VHS format, minicamcorder. The 'mini' concept will be limited by the large size of a VHS cassette, just as Betamovie suffers from this problem, but it will be interesting to see what National comes up with.

Easy to use

For the consumer the reason that the VideoMovie is such a leap ahead from the add-on Betamovie, is not only because you can see the video you are taking in a TV viewfinder as you shoot, but also the instant playback available anywhere there is a convenient TV set.

One novel activity the VideoMovie allows is to screen what you have taken on a TV, while recording another copy on the VCR. I found this simple and easy to do. It works on all formats of VCR, Beta, 2000, U-matic or even TV studio gear. All that is required is that you carry in the pocket or bag, a black box RF unit with connectors, smaller than a cigarette pack. Connectors go from the unit to the video-out port on VideoMovie, where it also gets power, and to the TV aerial input. An RF modulator for video and audio, it converts video and sound from the VideoMovie to a UHF TV signal with adjustable frequency to avoid local channels. A second port is for the TV aerial to be plugged into the unit and a switch allows either VideoMovie or TV

input to the VCR. This signal is tuned by TV or VCR in the normal way.

But the VHS-C 64 dollar question in the US is, "Okay, I would like to play VHS-C shots on my, or my friend's home VHS-VCR: how?"

Answer, "No problem. JVC has produced one of those gismos that makes a messy conversion a slick trick". The C-P3/U adaptor is the same size as an ordinary VHS video cassette and looks like one without tape spools. The VHS-C is easily placed inside it and as the catch snaps shut it comes alive in your hands. Inside a tiny motor whirrs; levers open the compact cassette, remove the tape and spread it out, a pointer on a dial shows progress and as you watch, it become full VHS format compatible. It takes four seconds for the metamorphosis and plays back or records like a normal video cassette on any VHS video. To change back, the catch is pushed and again the battery motor reverses the process; the lid opens for removal and a red wedge comes out the side to prevent accidental insertion without a VHS-C inside. It is a fun thing to use.

Existing VCR owners not anxious to duplicate their machinery just to go video-portable will find the VHS-C adaptor a useful piece of equipment.

Editing out the inevitable flub or dull bit while making a dub is fairly easy also. Just put the copying VCR in and out of pause in the record mode, copying only the scenes played on the monitor which you wish to retain. Editing is one of the great opportunities of video and often overlooked or regarded as too hard, and a small loss in quality, if good machinery is used, is far outweighed by the tight professional result.

VideoMovie specifics

The JVC VideoMovie at first looks to be an ordinary video camera. A small window revealing a tape spool gives the secret away. It is a 'camcorder', a combined videocamera and VCR.

In size, the VideoMovie is less than many of the videocameras I have reviewed recently. With lens-hood, TV finder and battery it measures 17.5 (w) x 13.6 (h) x 34 (d) cms. It comes with a shoulder rest/strap; conveniently, it hangs lens down and is not very cumbersome. Nett weight of the VideoMovie is specified as 1.9 kg! On my balance it weighed 2.25 kg with shoulder frame and carry strap, but without battery or videocassette. With 245 gm for a 1 hour battery and compact cassette at 15 gm, it was all up less than 2.5 kg! A Betamovie with battery and 130 minute video cassette and no auto focus weighted in at 3.06 kg. Combining full videocamera/VCR features and VHS compatibility, the VideoMovie represents a clear breakthrough in weight, size and convenience. Is it therefore reasonable to expect some serious quality compromises? ▶

Under test, using as benchmarks my lab monitor system, there were some faults, but not of great importance. The quality of replay from the VideoMovie via the blackbox RF converter was not top quality, but better than many economy videocamera/VCRs I have tested. Using the direct video output by BNC connector to monitor, it was of a very good standard and marginally better again when I tested the video on compact cassette, played back on my 'benchmark' VCR by using the adaptor C-P3/U. I doubt if the loss of definition compared to top video systems would be detectable on average home TVs.

The secret of the VideoMovie's size and weight lies in the entirely new head drum and loading system which has been reduced by one-third in diameter. The VHS signal pattern has been maintained by a revolutionary 4-head sequential recording system and a new 270 degree wrap/parallel loading system. Full marks to JVC!

The features in VideoMovie are really 'state of the art', with very good auto or manual white-balance with three hour memory to hold setting. It also includes iris, auto and manual, coupled to the high band saticon half-inch camera tube with a high sensitivity and a low level select, for colour down to a minimum of 15 lux with little lag (trails from bright lights on black background).

The viewfinder is detachable and as a half-inch screen CRT, it shows over the video picture, computer style function and warning messages, as well as date titling.

The lens system is a small but efficient, f/1.2, f=8-48 mm and 6:1 + macro with power zoom, daylight or tungsten filters and tripod mount.

VCR functions are full scale and at your fingertips. Every stop is auto-back-spaced for clean cuts. An automatic recording-lock system allows power conservation without editing loss. The 'review', a flash of a few seconds in the viewfinder showing the last take is almost an essential (but only included in the best video systems).

The two way shuttle search is also a great feature in playback and can be operated with the VideoMovie at eye-level during takes to check results. The light weight and shoulder frame allow the VideoMovie to be left at eye-level for long periods without fatigue. Shoulder and head-rested shots are many times more steady than shots with a hand-held videocamera.

Many accessories

Making semi-essentials accessories allows cost control of the initial purchase but they should be continually reviewed by owners. Your video can be only half alive without a good range of accessories.

Batteries are important components for video and the VideoMovie has an option

WINNERS & LOSERS

There are winners and losers in every arena. The video gladiators have been locked in a bloody contest of claim and counter claim, feature and counter feature. At this moment, with the release of JVC's GR-C1 VideoMovie camcorder (industry name for a VCR and Videocamera in one piece), the originator of the VHS format has a foot firmly on the throat of Beta. JVC is looking for a thumbs-up, or thumbs-down to finish the contest.

The consumers, who are the audience in this colosseum, are in a bad mood about the two formats. They prevent free interchange of video as possible in audio cassettes. It looks as though the thumbs will go down for a lingering departure of Beta over the next few years.

There is no room for two champions in the video arena and the release of the GR-C1 camcorder, looks like a mortal blow to Betamovie which lacks both a TV viewfinder and instant playback, both features included in VideoMovie. If Betamovie does survive JVC's thrust, National, JVC's Samurai comrade, will probably deliver the coup de grace when they release a small camcorder with full features using a standard VHS cassette.

If this were not enough, Beta thought its hi-fi would give them an edge; but JVC has just released a video hi-fi in VHS format. It plays for eight hours, using four-hour video cassettes; audio response is in the CD audio specification area and allows recording. This format fight involves billions of dollars of turnover in years to come. It makes a football final look like a pussyfoot contest.

The article here is a hands-on assessment of this latest product of the video industry, by an expert in photography, audio, video, and Australia's pioneer of Univac, the first in computers. He also happens to have been a journalist, off and on, for 47 years.

of battery packs. One is approximately 30 minutes and the NB-P6U is 45 minutes. In practice I found it more like 60 minutes. They are very light and small: 0.245 gm. You could carry several in the pocket or bag. The AA-PIEG charger will run the VideoMovie without battery as well as recharge. A very small BB-P1EG charges batteries only. They take only about 30 minutes for a charging. A great feature is that these very thin batteries easily slide on or off the back of the VideoMovie or charger and lock firmly. No more flapholes to find, or wrong way ups and arounds.

The black box TV/RF unit, shoulder frame and carry strap, also the VHS cassette adaptor, have been described as essential parts of the Videomovie; there is a car battery adaptor, pause remote control and super directional microphone, extension cable, as well as the usual BNC and TV connector cords.

The VideoMovie is housed in a port wine coloured carry case with a black soft moulded interior to nest in the camcorder and all its main accessories, safe from shock and lockable from little fingers. There are handles top and side.

The last thing you would expect in a hand-held camcorder is a very comprehensive titling system, but this is just what VideoMovie offers. It is a light, small unit that shoes on to the top of the camcorder and looks like a pocket calculator. It offers some of the most sophisticated character generation I have seen in video; 46 different characters and time, set Dymo fashion, date stopwatch, lap-time. Titles can have 60 characters per frame and 14 pages of text can be memorised, one for date, lap-time and

title, seven for standard titles, four for *zooming titles*, and two for *scrolling titles*! If that is not enough, you can reduce/enlarge and move them to a corner of the screen where they do not cover the bride and groom's kiss.

Summary

There is no way that the advent of JVC VideoMovie can be described as other than a revolution in video. Radio was never really portable before the transistor and neither was video really portable before this one piece camcorder. Getting all video's technology into something similar to a lady's handbag, and no heavier, when only six years ago it weighed over 10 kg, must be one of the great technical feats of this century. JVC has again shown the way and unless they can patent size and design, the competition is so fierce others must follow.

Eight mm video camcorders are close and sizes may be smaller and lighter, but will the features match VideoMovie? One great feature is the compatibility with many millions of the VHS-VCRs all over the world. The Pathe 9.5 mm home movie film with centre sprocket holes dominated home movies in the 30s, until someone showed you could expose half the commercial standard 16 mm film with 8 mm frames, then turn it over and expose the other side in the opposite direction. The processor then split it in half and you got twice the length back. The cheaply available standard was 16 mm film. Soon, pre-split 8 mm film was the big seller and 9.5 mm with a better format and bigger frames vanished. "Look behind to see what may be just ahead." ●

WANTED
in good condition:
ELECTRONIC PARTS
and
COMPUTERS
also
TEST EQUIPMENT
CASH REWARD!
Phone 569-9770

PRICE BUSTERS...

HOUSE ALARM KIT ONLY \$59
Complete home security system with a push-button entry/exit code, siren module and 4 sets of reed switches, instruction book etc. Battery operated.

ROCKER SWITCHES
NOW ONLY **9c** EACH
250V 3A MAINS OR 3 POLE CHANGEOVER

POWER SUPPLY KITS SALE!
SAVE 10% off the usual prices and we pay the freight, this month only. Kits assembled by Altronics.
K3300 E.A. Lab Power Supply, 2-50V 5A \$139.50 less 10%.
K3325 ET1 Lab Power Supply, 0-40V 5A \$175.00 less 10%.
K3250 ET1-160 13.8V 10A High Current P.S.U. \$89.50 less 10%.
K6750 12-240V AC/DC Inverter 300 Watts \$199.50 less 10%.

2Kg handy SURPRISE KIT
WORTH UP TO \$60
Transformers, Electros, Poly & ceramic caps, Resistors, Switches, Semiconductors, Pots, etc.
\$12
INTER-STATE POST- ADD \$3.00

STEREO SIMULATOR...\$30
For TV, VCR etc, active electronic circuit (not passive R's and C's), simulates stereo from any mono source. It's actually, very hard to distinguish from the real thing! Adds a new dimension to your TV sound; 240V AC. Was \$59.95, now.....\$29.95

USED COMPUTER EQUIPMENT.
2x8" 55:50 500Kbyte Olivetti disk drives, in cabinet incl. power supply. All in working order, guaranteed. \$350.00

SORCEROR COMPUTER \$400
As brand-spanking new, and in orig. carton, is this beaut Sorceror (from deceased estate). Cheap buy at only \$400

PIEZO TWEETER...\$12.50
100 Watt rating super-horn, rectangular, flared, needs no crossover. 3KHz-30KHz, 8 ohms, wide dispersion. New!

TV ANTENNA AMPLIFIER 6dB GAIN!
VHF/UHF/FM Dual Outputs
\$19

Transformers
9.7Vx2 20A
MAINS INPUT: 0, 240V, 265V
OUTPUT: 2 windings 8V-10V depending on primary tap.
\$39
WERE \$69 135x110x110mm
Ideal 13.8V 20A

FANS Ex-computer
5 inch
MUFFIN, 115v \$6.00
ROTRON, 220v \$8.00
ETC.

5mm RED LEDs
5c EA
LIMIT 40 PER CUSTOMER!

ROCK-BOTTOM PRICES ON...
1N4004 400V 1A rectifiers...7c
1N5401 100V 3A rect.....25c
400V 6A bridge rect.....\$1.50
400V 25A bridge rect.....\$3.50

CAR ALARM INDICATOR \$7
Twin high-brightness LEDs, alternately F-L-A-S-H-I-N-G will probably scare off any burglar, even if you don't actually have an alarm. The black metal box is easily inst'd under dash. 12v...\$7

DIGITAL PHONE DIALERS
PUSH-BUTTON WITH MEMORY
DIRECT REPLACEMENT FOR STANDARD ROTARY TYPE - EASILY FITTED IN MINS. (Not Telecom approved)
\$9.95 EACH











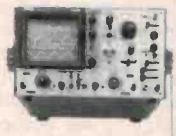
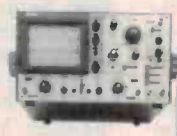

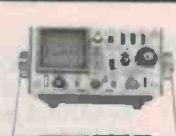
CENTRONICS PRINTER PLUGS
GENUINE AMPHE-NOL PLUGS - only from us at this price!
\$8 EACH LIMITED QTY.
36 way, gold-plated pins, genuine USA made plugs.

NEW PROFESSIONAL ALARM CONTROL UNIT
\$99
Similar alarm boxes sell for upto \$199. Built for Aust. home, office, factory!

SCOOP BUY!
HALF PRICE ALARM CONTROL BOX - JUST \$99 Built/tested.
Similar alarm boxes sell for upto \$199. Built for Aust. home, office, factory!
● Heavy duty steel cabinet (lockable).
● Sophisticated & versatile circuitry.
● Adj. entry, exit & adj. reset delay
● N.O./N.C. instant, N.C. delay oper.
● Inbuilt siren, add horn speaker(s).
● 6x LED status indicators, all modes
● Inbuilt 24hr panic or fire circuit.
Lots more features, send for brochure

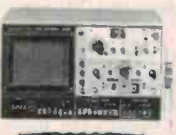
PRE-PAK electronics p/l **1a WEST ST, LEWISHAM, NSW** **569-9797** **Phone or mail order**
electronics p/l **24 HR PHONE ORDER SERVICE** **BANKCARD accepted**

HITACHI OSCILLOSCOPES

Oscilloscopes				Mini Portable Oscilloscopes	
 V-1050F 100MHz QUAD-TRACE WITH DLY SWEEP	 V-650F 60MHz DUAL-TRACE WITH DLY SWEEP	 V-353F 35MHz DUAL-TRACE WITH DLY SWEEP	 V-203F 20MHz DUAL-TRACE WITH DLY SWEEP	 V-509 50MHz DUAL-TRACE WITH DLY SWEEP	
 V-422 40MHz DUAL-TRACE	 V-222 20MHz DUAL-TRACE	 V-212 20MHz DUAL-TRACE	 V-211 20MHz SINGLE-TRACE	 V-209 20MHz DUAL-TRACE	
Digital Storage Oscilloscopes		Storage Oscilloscope		Waveform Monitor	Vectorscope
 VC-6041 40MHz/2 CHANNEL	 VC-6015 1MHz/2 CHANNEL	 V-134 10MHz DUAL-TRACE		 V-099 (Type NTSC) V-098 (Type PAL)	 V-089 (Type NTSC) V-088 (Type PAL)

2 YEAR WARRANTY

SC STANDARD COMMUNICATIONS PTY. LTD.

SYDNEY (02) 816 4755 **MELBOURNE** (03) 584 8099 **BRISBANE** (07) 273 4355 **ADELAIDE** (08) 42 9356 **PERTH** (09) 330 5322

CROs

— a closer look

Jon Fairall

ETI's mega CRO survey — all the cheapest CROs plus a bit on how they work.

THE BEST PIECE of test gear ever invented is the human brain. It's flexible, transportable and extremely cost effective. Certainly, if you can't use it you'll have difficulty using anything else.

It does have a few disadvantages though. For one thing, it can't sense electricity directly. You can't hear electricity, or see it, and feeling it could be an extremely terminal sort of test. That's where a CRO comes in.

A CRO is a device to allow you to see what's happening within a circuit. Used properly, it's an extremely powerful piece of equipment.

The basics of CRO operation have been dealt with before, both in this magazine and in numerous other articles and text books. In this article we want to take a more in-depth look at certain parts of a CRO. We have also constructed a table of most of the cheapest CROs available in Australia at present, together with some of their more important features.

Triggering

The purpose of a CRO is to 'paint' a waveform on the screen of a cathode ray tube (CRT). The vertical movement of the trace is arranged to be proportional to the voltage level of the input signal. The horizontal position of the trace is made proportional to time, so that a graph is plotted showing voltage against time.

The horizontal 'timebase' movement of the trace is achieved by feeding a sawtooth waveform of known slope to the deflection plates. This makes the trace move steadily across the screen from left to right. When the trace gets to the right hand side of the screen the beam is turned off (blanking) and moved rapidly back to the starting point again (flyback).

These two functions, the vertical and horizontal deflections of the trace, must be synchronised to present a meaningful picture on the screen. To see why, imagine what would happen if we tried to input a simple sine wave with no synchronization. The trace would oscillate up and down the screen under control of the input, while at the same time racing backwards and forwards across the screen under control of the timebase. If the timebase was set to be slow we would see a vertical line moving slowly

from left to right. If it was fast we would see a broad band, it's width determined by the peak to peak voltage of the input.

But if the two were synchronised so that the timebase was locked to some exact multiple of the input frequency, then the trace would move through exactly the same path again and again. The sine wave would be drawn on the screen, an exact replica of the voltage on the input.

The process of synchronising the horizontal and vertical deflections of the trace is known as triggering. Triggering is achieved by taking some of the signal being applied to the vertical amplifier and applying it to a gate circuit.

When this signal reaches some preset level the gate circuit emits a pulse, which starts a sawtooth generator running. This sawtooth is the controlling voltage for the horizontal deflection.

The exact speed at which the sawtooth generator runs is set by the time/div switch on the front panel. The level at which the triggering circuit fires a pulse to start the sawtooth generator is also set from the front panel, by a control usually labelled 'Trigger level' or somesuch.

This system works well provided the signal on the input is reasonably uncomplicated. If it is a simple sine or square wave the CRO will provide a picture with the trigger level set anywhere within the peak to peak voltage of the input.

But this basic triggering circuit is not foolproof. Bear in mind that it is set up so that it fires the timebase, waits for the flyback, then waits for the voltage level to cross a certain threshold before starting the timebase again.

If the signal is not a simple repetitive wave, it can fool the trigger circuit in a number of ways. Perhaps the simplest is a complex wave where two or more waves of similar frequency but different amplitude are summed together.

In Figure 1, notice that when the trigger is set at level Y, and the sweep only runs to Z, it will provide trigger pulses both at points B and D. The trigger will not fire at C, since it is sensitive to the direction of the input, as well as its level. This can be controlled with the +/- switch on the front panel.

As a result two waveforms will be painted

on the screen. First it will trigger at B, and run through to Z. Then it will look for the next negative going crossing of the trigger level voltage, which occurs at point D.

The resulting picture is shown in Figure 2. Note that if the timebase is shortened or lengthened, other combinations are possible. However if the trigger level is moved up to X in Figure 1 then triggering must take place unambiguously at E or F.

Of course, a waveform can be complex in other ways. A pulse train, for instance, could consist of a repeated but irregular sequence of marks and spaces, as in Figure 3. Assuming the first trigger point is at A, and assuming the timebase is set to sweep as far as the line Z, the next trigger point will be B. Once again, this will result in a confused image on the screen.

One way of curing this problem is to extend the timebase so that it falls around D, in which case it will trigger at C. If, for some reason you don't want to do that, another very useful function is available. This is the 'hold off' function. It actually stops the sawtooth generator for a suitable interval, to prevent retriggering. In Figure 3 this would be the time period between Z and D.

Delay

It often happens that the most interesting part of a signal can't be seen with sufficient detail in the normal display mode. This might be something like the ringing that occurs when a voltage level changes dramatically, as it does in a pulse train. (See Figure 4.)

One way of getting a closer look at any given point on the display is with the trigger delay and magnification functions. The delay holds the sawtooth generator for a period of time determined by the user, before releasing it to run normally. The effect of this is to move the displayed waveform to the left. The magnification just speeds up the trace, thus spreading it out across the screen.

When these two functions are used together the result is to magnify any given piece of the trace for closer examination. Some CROs make it possible to observe the entire trace on one channel while using a delay function of the same input on the other. Sometimes the area under inspection is highlighted, so that it is possible to precisely select a particular area for inspection.

Most CROs give the user a selection of the way in which the trigger circuit is connected to the input. Commonly, a choice of ac, dc, hi-pass, low-pass and TV input coupling is provided.

AC and dc are self explanatory. Hi-pass and low-pass filtering are there to prevent noise from causing false triggering. TV is used to optimize the trigger for looking at TV signals, either frame or line. A special TV input is used because TV signals form a difficult subject for CROs to latch onto, but at the same time are very common. Using the TV setting in conjunction with the timebase delay control, it's possible to look at

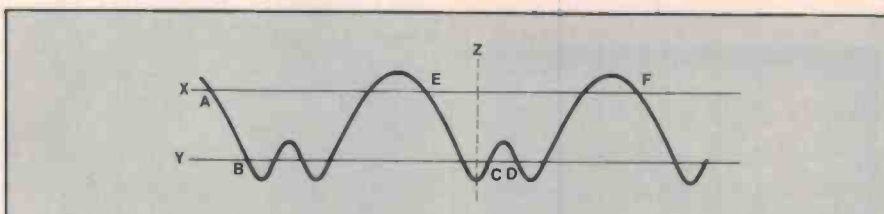

Figure 1: An irregular waveform applied to the input of a CRO. The horizontal lines are the trigger levels.

both frames and any of the lines within the frame.

Multi-trace operation

It's difficult to find single trace CROs these days. In fact there are only seven out of 64 in our survey.

There are two ways multiple traces can be displayed on the screen. One is the multi-gun approach, in which one input is fed to one gun where it forms an image in the normal manner, and the second input is fed to another gun to form a second image in the same way. This method is expensive, but it does result in very high quality CROs.

A more realistic alternative is to use one gun and one electron beam to form two traces. This is done in a number of ways. The trace can actually paint alternate lines on the screen, first doing channel 1 and then channel 2 and back to one and so on. This option is selected with the 'Alt' (alternate) switch. Another method is to switch rapidly between both traces. This is called 'Chop'.

All these modes of operation have advantages and disadvantages. For a given acceleration voltage, the multigun assembly gives the brightest display. It also operates completely independently of the frequency of the signals being displayed.

On the other hand, the single gun pattern is significantly dimmer when displaying two traces, other things being equal. It has to be, since the trace must now cover twice as much area as before — or if you like, it only spends half its time on each trace. Naturally, this problem gets worse the more traces there are.

Of course, other things are seldom equal. The accelerating voltage can be increased in multi-trace scopes to allow for the dimming of the screen. As a result single gun scopes are the standard and multiguns a rarity.

There are two other modes of operation that appear on most CROs. These are the 'Add' and 'Sub' functions. When either of these is engaged, the two inputs are added or subtracted and the resultant displayed on the screen.

There are a number of specialist applications where these functions can be useful. One rather more general one is in noise cancelling. Figure 5 shows a pulse train riding on a 50 Hz mains hum. If the mains hum can be introduced into the second channel and then subtracted from the first, the result will be waveform C.

Strictly speaking it is not necessary to have both an add and subtract function.

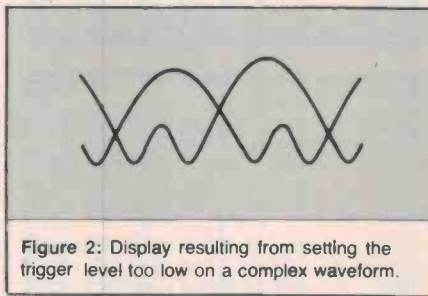

Figure 2: Display resulting from setting the trigger level too low on a complex waveform.

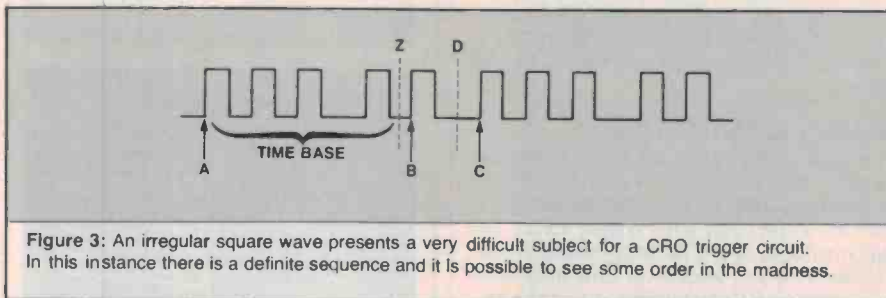

Figure 3: An irregular square wave presents a very difficult subject for a CRO trigger circuit. In this instance there is a definite sequence and it is possible to see some order in the madness.

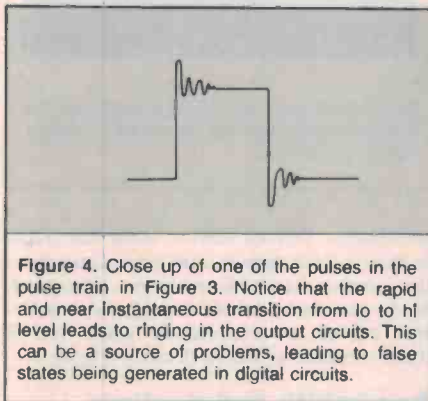

Figure 4: Close up of one of the pulses in the pulse train in Figure 3. Notice that the rapid and near instantaneous transition from lo to hi level leads to ringing in the output circuits. This can be a source of problems, leading to false states being generated in digital circuits.

most CROs have the facility to invert one or both traces, so it is always possible to implement a subtract function by inverting one of the channels and adding.

Storage

There are a number of very important applications where we wish to record the response of a circuit to a non-repetitive event. An explosion, the closing of a switch or any other form of one-off transient are examples.

A normal CRO is nearly useless in this type of application. The event comes and

goes before it can register as more than a flash of the trigger lock LED. What is required is a *storage* CRO. This is a type of CRO that allows you to retain an image of a single transient event.

There are a number of ways this can be done. The cheapest, and historically the first, method is the variable persistence CRO. Visual persistence is the name given to the phenomenon that allows you to see a moving spot as a line (or indeed, a succession of still images in the movies as motion.)

The phosphors that coat the inside of the CRO screen have a definite persistence as well that aids this effect. That is to say, when illuminated by the electron beam they do not immediately switch off once the beam has passed, but remain glowing for some small finite time.

It is possible to vary this time to quite a large degree. The result is that a semi-permanent record remains of the path of the trace. Naturally this is continually updated

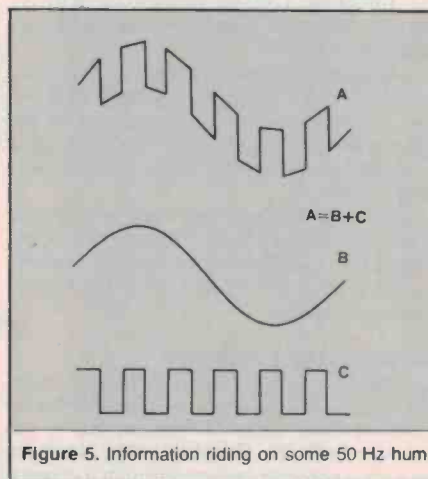

Figure 5: Information riding on some 50 Hz hum.

there are facilities to turn the trace completely off when the CRO is operated in this mode, to avoid obliterating the wanted waveform.

In fact it is often possible to operate in a single-shot mode. When this function is engaged the trace will make only one sweep after the trigger circuit has been activated. It must be manually reset in order for the next line to be displayed.

This mode, together with variable persist- ▶

ence, makes it possible to capture very short events. However it is done at the cost of turning the screen accelerating voltage up to abnormally high levels. This has all kinds of unacceptable consequences for the life of the display, so other methods of achieving the same end are preferred.

The modern solution is digital storage. This involves the sampling of the input waveform at a predetermined rate, usually several hundreds of kilohertz, and the subsequent re-display of the same. This system involves no special manipulation of the screen at all.

The input is converted into a digital word, eight to twelve bits long, and stored in on-board RAM. The display then effectively is used to read out the contents of memory.

The accuracy with which digital storage can work depends on the size of the memory available, and the rate at which the analogue to digital conversion can be made. It's usually quoted in terms of words, each word consisting of a sample or description of the voltage level at a particular point across the screen. Figures of 400 words are common for the types of CROs in this survey.

Sweep magnification

Sweep magnification is another useful function for examining portions of the waveform in greater detail. We have mentioned it before in connection with trigger delay and this is without doubt its most profitable use. However, it is common to find magnification even on CROs without any of the fancier functions. Usually, this will be of the x5 variety, although there are some with x10 and even x100.

All of these work by stretching the timebase, so that it appears that the screen is just a small window into a portion of the whole line. The big disadvantage with using magnification is that it results in a dimming of the trace.

There have been some modifications recently to this basic idea. One of these is the 'Mix-Mag' function, in which it is possible to extend part of the trace while leaving the rest as normal.

Component testers

Component testers are an optional extra that plug into the input of many different types of CRO. One CRO in our survey has a tester built in. Generally they work by passing a variable current through a component and measuring the voltage across it. The tester sends a trigger pulse to the timebase to synchronise the timebase with the current test.

The result is a series of characteristic patterns on the screen for given types of component. A resistor shows up as a straight diagonal line — a perfect geometric expression of Ohms' law. A capacitor is an oval sloping from bottom left to top right, and an inductor slopes the other way around.

Semiconductors have their own individ-

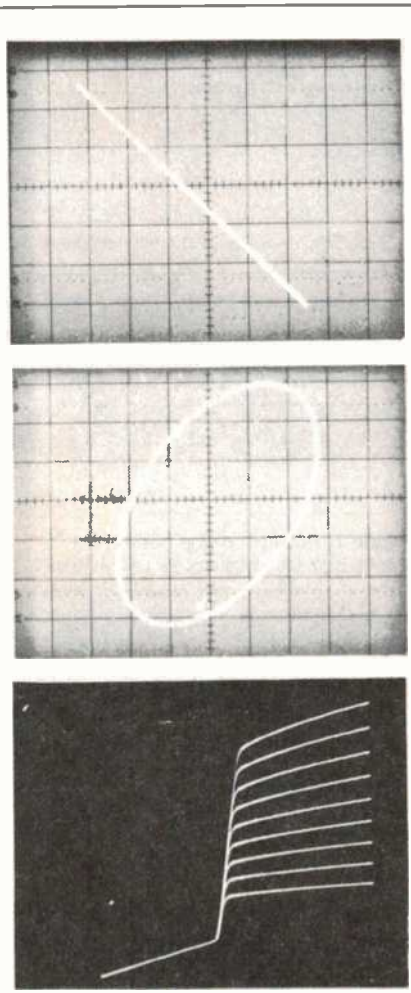

Figure 6. Output from a component tester. The horizontal axis should be interpreted as current, vertical as voltage.

ual shapes. Diodes tend to show flat traces in their cut-off regions and vertical traces as the junction barrier is overcome. It is possible to generate a whole family of characteristic curves for a transistor using one of these devices, as we've done in Figure 6.

Bandwidth and risetime

Probably the most fundamental measure of the quality of a CRO is the bandwidth of the vertical amplifier. As with most other devices it is measured at the -3 dB point, i.e.: the point at which the amplitude response is 0.707 that of the maximum response. (See Figure 7.)

Risetime is a closely related figure. It tells you how long it will take the amplifier to go from 10% to 90% of the full value of an instantaneous change in voltage applied to the input. So it's a measure of how fast the output of the vertical amplifier can track the input.

In the case of a sinewave these two fig-

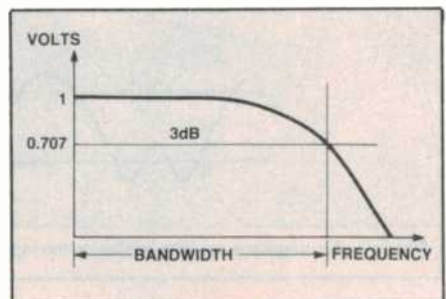

Figure 7. Frequency response versus frequency. This is the definition of bandwidth used in most ac circuits.

ures would represent different sides of the same coin, related by the formula

$$tr = 0.35 / bw$$

However, it's not difficult to imagine waveforms where this is not the case. A square wave for instance, may have a very low frequency but extremely fast rise times.

In cases like this there is still a very close relationship between the two. The quickest way to explain it is to use Fourier analysis, a mathematical technique that starts from the premise that any repetitive waveform can be expressed as the sum of a number of sine waves. Using Fourier analysis it turns out that some quite complex looking waves can be expressed as the sum of a small number of sinewaves. A good approximation to a square wave can be had by adding together just three sine waves, the first three odd harmonics, i.e.: a sine wave of the same frequency as the square wave, plus ones of three and five times this frequency.

This leads to a rough rule of thumb when ordering a CRO. Buy one with a risetime equivalent to a bandwidth at least three times faster than the fastest square wave you are ever likely to need.

Of course, in all of this we have been considering the bandwidth as it applies at the input of the CRO. In practice, you don't have access to the CRO inputs so much as the CRO probes. In reality then, we need to consider the performance of the CRO including the probes.

As a matter of practical fact the probe leads can have a very real effect on CRO performance, especially at high frequencies. The input resistance and capacitance, should be of a similar magnitude to the input specifications of the CRO to avoid degrading the performance of the whole measuring system.

To put some numbers on this, it's worth memorising the formula:

$$Tr = 2.2RC$$

where R is the input resistance of the probe in parallel with the output resistance of the source, and C is the probe capacitance. Tr is then the rise time of the measuring system. ▶

USER'S GUIDE TO LOW COST CROS

MAKER	DISTRIBUTOR	PRICE (\$)	B/W (MHz)	CH	SENSITIVITY				RISE TIME (nS)	CRT VOLT (kV)	INPUT VOLTS (max)	Zin (M/pF)	REMARKS
					VOLTS MAX (V)	MIN (mV)	TIME MAX (s)	MIN (μs)					
Kikusui 538A	Dindima	256	5	1	5	10	0.2	1	70	1.2	—	1/30	
Goodwill GOS955	Emona	269	5	1	10	10	10	10	70	—	600	1/35	
Goodwill GOS3310	Emona	297	10	1	5	5	10	0.1	55	1.3	600	1/35	
Kikusui 559A	Dindima	399	5	1	1	10	10	1	70	1.2	—	1/30	
Hung Chang OS620	Paton	450	20	2	20	5	0.5	0.2	17	2	600	1/20	
National VP5215A	Scientific Devices	450	15	1	2	1	0.5	0.2	23.4	2	600	1/30	
Meguro MO1251	Elmeasco	465	20	2	20	5	0.5	0.2	17	2	600	1/20	Component tester
Aron BS601	Elmeasco	465	20	2	20	5	0.5	0.2	17	2	600	1/20	
Kikusui 5509	Dindima	497	10	1	5	10	0.2	1	35	1.6	—	100k/28	
Trio CS1560All	Parameters	545	15	2	20	10	0.5	0.5	23	2	600	1/22	
Kikusui 5519	Dindima	560	20	1	10	5	0.5	0.2	17.5	2	—	1/30	
National VP5216A	Scientific Devices	567	15	2	2	1	0.5	0.2	23.4	2	600	1/30	
Kikusui 5513	Dindima	590	10	2	5	10	0.1	1	35	1.6	—	1/30	
Iwatsu SS5702	Electrical Equipment	598	20	2	10	5	0.2	0.5	17.5	2	500	1/30	
Hung Chang OS615S	Paton	600	15	2	10	2	0.5	0.5	24	1.5	—	1/20	Portable
Trio CS1012	Parameters	611	10	2	5	1	0.5	0.5	35	2	500	1/35	
Hitachi V212	Standard	613	20	2	5	5	0.2	0.2	17.5	2	500	1/30	
National VP5220A	Scientific Devices	620	20	2	2	1	0.5	0.2	17.5	2	600	1/30	
BWD 824	BWD	625	35	2	20	2	1	0.2	10	6	800	1/30	
Aron BS310S	Elmeasco	625	15	2	10	2	0.5	0.5	24	1.5	600	1/20	Portable
Hung Chang OS635	Paton	630	35	2	10	5	0.5	0.1	10	6	600	1/20	
Kikusui COS5020	Emona 539	631	20	2	5	5	0.5	0.2	17.5	2.2	—	1/30	Delay, single shot
Trio CS1022	Parameters	649	20	2	5	1	0.5	0.2	17.5	6	500	1/32	
Kikusui 5502A	Dindima	658	5	2	1	10	0.1	1	70	1.6	—	1/30	
Meguro MO1252	Elmeasco	675	35	2	10	5	0.5	0.1	10	6	600	1/20	Delay
Aron BS635	Elmeasco	675	35	2	10	5	0.5	0.1	10	6	600	1/20	Delay
Hitachi V222	Standard	749	20	2	5	5	0.2	0.2	17.5	2	500	1/30	
Kikusui COS5021	Dindima	767	20	2	5	5	0.5	0.2	17.5	22	—	—	Delay, single shot
National VP5231A	Scientific Devices	770	30	2	2	1	0.5	0.2	11.7	6	600	1/30	
Trio CS1352	Parameters	845	15	2	10	2	0.5	0.5	24	1.5	600	1/22	Portable
Hitachi V203F	Standard	849	20	2	5	5	0.2	0.2	17.5	2	500	1/30	Portable, delay
BWD 821	BWD	850	50	2	20	5	1	0.2	7	6	—	1/30	Mix-mag.
Hung Chang OS645	Paton	940	45	2	5	5	0.5	0.2	7.7	15	600	1/20	Delay, single shot
Kikusui COS5041	Emona	951	40	2	5	5	0.5	0.2	8.8	12	—	—	Delay, single shot
Kikusui COS5040	Dindima	978	40	2	5	5	0.5	0.2	8.8	12	—	1/30	Delay, single shot
Aron BS625	Elmeasco	998	45	2	5	5	5	0.2	7.7	15	600	1/20	Delay, single shot
BWD 830	BWD	999	35	2	20	5	1	0.2	10	6	—	1/30	Delay
Iwatsu 5706	Electrical Equipment	1000	30	3	10	5	0.5	0.1	17.5	12	—	1/32	Delay
Hitachi V209	Standard	1049	20	2	5	5	0.2	0.5	17.5	1.5	500	1/30	Portable
Iwatsu 5705	Electrical Equipment	1100	40	3	10	5	0.5	0.1	8.7	12	800	1/32	Delay
Hitachi V353F	Standard	1119	35	2	5	5	0.2	0.2	10	5.2	500	1/30	Delay
Trio CS1577A	Parameters	1156	35	2	10	2	0.5	0.1	10	6	500	1/22	
Trio CS1040	Parameters	1175	40	3	5	1	0.5	0.01	8.8	12	500	1/27	
Hitachi V422	Standard	1249	40	2	5	5	0.2	0.2	8.8	12	500	1/30	
Philips PM 3211	Philips	1355	15	2	10	2	0.2	0.5	23	4	800	1/25	
Kikusui COS5060	Dindima	1392	60	3	5	5	0.5	0.05	6	12	—	—	Delay
Trio CS1060	Parameters	1495	60	3	5	1	0.5	0.5	5.8	16	500	1/27	
Hitachi V650F	Standard	1549	60	2	5	5	0.5	0.05	5.8	10	500	1/30	Delay
BWD 835	BWD	1550	60	2	20	5	1	0.05	5.8	10	—	1/30	RAN standard, delay, portable
Iwatsu SS5710	Electrical Equipment	1550	60	2	10	5	0.5	0.05	5.8	15	800	1/32	Counter and DMM available as extras
Kikusui DSS5020	Emona	1678	20	2	5	5	1	0.55	17.5	2	800	1/25	Digital storage
Hitachi V509	Standard	1795	50	2	5	5	0.2	0.1	7	12	500	1/30	Portable, delay
Hitachi V134	Standard	1837	10	2	5	5	2	2	35	2	500	1/30	Storage
Trio CS2075	Parameters	1995	70	4	5	5	0.5	0.05	5	12	800	1/22	8 trace, delay
Kikusui COS5100	Emona	1999	100	3	5	5	0.5	0.02	3.5	18	—	1/25	Delay, single shot
Kikusui COS5020ST	Dindima	2010	20	2	5	5	1	0.5	17.5	3.15	—	—	Variable persistence, storage
Philips PM3217	Philips	2020	50	2	10	2	0.5	0.1	7	10	800	—	Dual timebase option delay
BWD540	BWD	2100	100	2	50	5	1	0.05	4	12	—	—	Portable, single shot
Trio CS1100	Parameters	2158	100	2	5	5	0.5	0.02	3.5	16	500	1/22	Delay
Iwatsu SS5711	Electrical Equipment	2200	100	2	5	5	0.5	0.02	40	20	500	1/25	DMM available as option, delay, counter
Kikusui COS6100	Dindima	2300	100	5	5	5	0.5	0.02	3.5	20	—	1/20	Delay
Hitachi V1050F	Standard	2395	100	2	5	5	0.5	0.02	3.5	20	500	1/30	Delay
Trio CS2110	Parameters	2495	100	4	5	5	0.5	0.02	3.5	20	800	1/20	Delay, 8 trace
Kikusui COS6100A	Emona	2512	100	5	5	5	0.5	0.02	3.5	20	—	1/20	US Military, delay

The survey

We have arranged the 64 cheapest CROs we could find in price order. This is not an absolute ranking, because prices can be subject to fluctuations for all sorts of reasons. So a few words of caution: firstly, these prices do not include sales tax. If you have to pay it, add 20% for the government.

Secondly, some manufacturers include the cost of probes in their price while others don't, so you have to make allowances for that (\pm \$50 for a decent set). Thirdly, in the nature of the case, this is a very competitive market place, so special offers and deals are likely to abound. Confirm the prices of all the models you are interested in before making a decision. And don't be afraid to haggle.

Having said all that, though, the table probably gives a pretty fair indication of what you can get for your money. As far as we are aware it is a comprehensive look at the market below \$2500.

The only omission is kit CROs. These usually sell for around \$220 from Dick Smith, Jaycar, Altronics and other hobbyist suppliers. We have restricted our table to CROs you can buy ready to run.

I believe you'll find it interesting reading, even if you are not actually going to rush out and buy a CRO. The big surprise is just how cheap things have become over the last few years. The market starts at just \$256. For \$450 you can get a very respectable 20 MHz CRO. That would be sufficient for most hobbyist applications, including TV and digital troubleshooting. For less than \$500 you can obtain models with timebase delay.

If you have a little more money, notice that digital storage is now available for as little as \$1678. In fact, two different models of digital storage CRO and one variable — Persistence CRO are available for under \$2500.

It doesn't seem to be true that cheap CROs are necessarily lacking in quality, either. At least two of these surveyed have satisfied stringent military requirements — the BWD 835 is in service with the RAN and the Kikusui COS 6100 with some sections of the US Military.

The movers and shakers

The makers and distributors have been listed in the first two columns. We use the term 'maker' rather loosely. In the nature of the case oscilloscope manufacture is a fairly incestuous business, so it can be difficult to establish just exactly who does what, and where.

There was a rumour doing the rounds that there was one big factory somewhere between Tokyo and Seoul where all the Asian CROs come from. But it was only a rumour. We do know that Aron, Application, Hang Chung and Meguro all refer to the same beast in different clothing. Others may be in the same boat.

One company does stand out from the rest, and that is Kikusui, a Japanese manu-

facturer which aims to take over from Tektronix as the biggest maker of CROs in the world. For the last few years they have been marketing aggressively in the USA, particularly at the low cost end of the market with the results you see in the table.

Surprisingly enough, the distribution system seems relatively well ordered. A few of the big manufacturers distribute their own product, as does the only Australian maker in our survey, BWD. Otherwise, the distributors are the familiar ones who dominate the electrical market place for all sorts of products.

The only slight confusion you might find springs from the fact that both Emona and Dindima distribute Kikusui CROs. Their price structure tends to be somewhat different so it's worthwhile making a comparison before selecting.

The table

In all cases technical specifications are those that appear in manufacturer's data. It was obviously impractical to test them all ourselves. You may feel inclined to take certain figures with a pinch of salt.

In any event, the bandwidth figure is taken at the claimed -3 dB point, and rise time represents the time taken to rise from 10% to 90% of final value. In our survey we found values between 5 MHz and 100 MHz. This should be sufficient to cover most applications outside some rare high

frequency situations.

The maximum and minimum values of sensitivity for both amplifier and timebase are taken from the front panel labelling on all the machines. In general these will be extendible by five or sometimes ten with the magnification function.

Where available we have included the maximum permissible input voltage and the input impedance. This may be also be extended with the use of appropriate probes.

We have also included a column for the accelerating voltage used in the CRT. This is of some value when assessing cheap CROs, because it gives you some idea of the brightness of the trace during operation. As a rule of thumb when the voltage drops under 2 kV, you will have difficulty seeing a timebase running at 1 μ s or faster.

In the remarks column we have included some of the extra facilities that can justify some CROs being more expensive than one would expect given their bandwidth and number of channels. Such things as delay lines, component testers, portability and storage facilities come into this category.

References

ETI April 84 — Bandwidth, probing, and precise interval measurements — goes into probe considerations in some depth.

ETI December 79 — The ubiquitous oscilloscope — looks at the fundamentals of how a CRO works.

ETI January 79 — Use a scope — why you need one.

DISTRIBUTORS INDEX

Altronics: Stirling Street, Perth WA 6000. (09)328-1599. Supplies a Goodwill CRO in kit form.

BWD: Miles St, Mulgrave Vic 3170. (03) 561-2888. Australian manufacturer and distributor.

Dindima: PO Box 106, Vermont Vic 3133. (03)873-4455.

Dick Smith Electronics: PO Box 321, North Ryde NSW 2113. (02)888-3200. Supplies a kit CRO.

Electrical Equipment: 192 Pacific Highway, Arncliffe NSW 2205. (02)597-1155.

Elmeasco: PO Box 30, Concord NSW 2137. (02)736-2888.

Emona: 1st Floor, 720 George St, Sydney NSW 2000. (02)212-4815.

Hewlett-Packard: 31 Joseph St, Blackburn Vic 3130. (03)895-2895. A manufacturer of a fine range of oscilloscopes. Unfortunately all out of our price range.

Jaycar: 117 York St, Sydney 2000. (02)

267-1614. Another hobby supplier with kits available.

Parameters: 41 Herbert Street, Artarmon NSW 2064. (02)439-3288.

Paton Electrical: 90 Victoria St, Ashfield NSW 2131. (02)797-9222.

Phillips: 25 Paul St, North Ryde 2113. (02)888-0443.

Scientific Devices: 2 Jacks Rd, South Oakleigh Vic 3167. (03)579-3622.

Standard Communications: 6 Frank St, Gladesville NSW 2111. (02)816-4755.

Tektronix: 80 Waterloo Rd, North Ryde NSW 2113. (02)888-7066. Probably the biggest oscilloscope maker in the world, with some high quality products available. Unfortunately, it was all too expensive, and none of its CROs were included in our sample.

Vicom: 68 Eastern Rd, Sth Melbourne Vic 3205. (03)62-6931. Distributes a number of makes and models of CROs. Unfortunately, no details were forthcoming before we went to press.

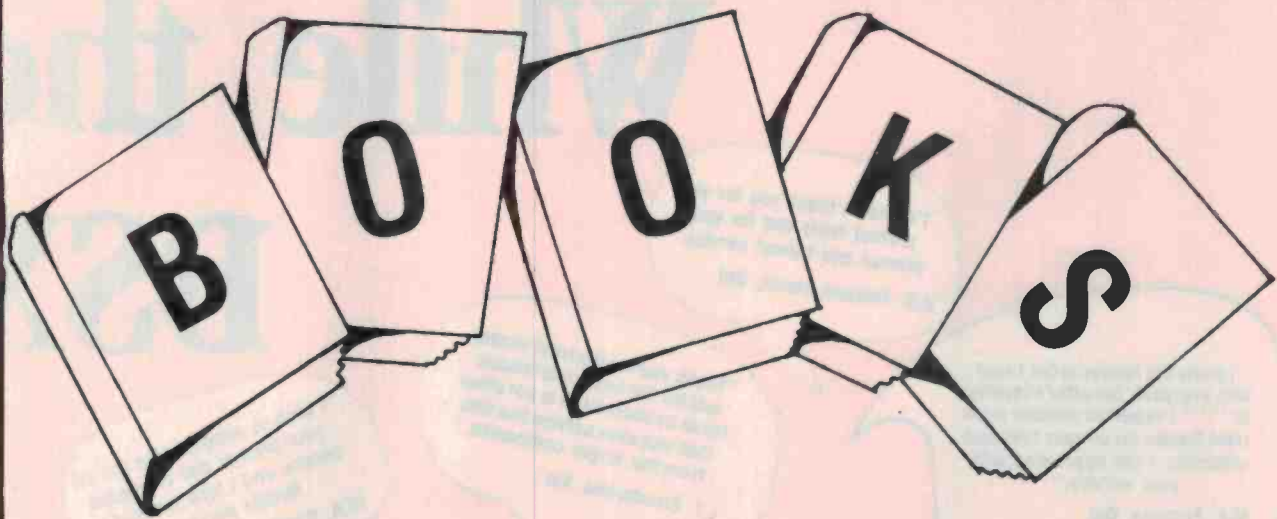

for the Computing Professional

DP Education (Books) is one of Australia's major mail order suppliers of computer books. Each book has been carefully selected from the books published by major publishers throughout the world and represent some of the best examples on their subject available.

We release a new book list approximately every six to eight weeks and you may obtain these by completing and returning the form below.

We would emphasise that these books are not for the beginner or home enthusiast and all books are chosen on the assumption of the reader having reasonable computer knowledge.

MONEY BACK GUARANTEE

If any book does not meet your approval and you return it to us within ten days in new condition, we will refund your payment (less postage and handling)

OUT SHORTLY
OUR NEW
ELECTRONICS BOOKLIST
(For the Electronics Professional)

PERSONAL BOOK LIST

I would like to receive your professional book list, please forward them as they become available.

Name

Organisation

Address

Please send me your booklist on (✓)

Computing Books Electronics Books

POST TO: DP Education (Books)
P.O. Box 289
Wahroonga 2076



While the DSX

"I'd like to thank you for your prompt reply and for your prompt and honest service."
K.G. Tannum Sands, Qld

"I knew the money order I sent was overpaid, but after shopping at ***** I expected another price rise! Thanks for all your time and attention. I am impressed with your service."
M.F. Pomona, Qld

"Thank you for the trust shown, and for the haste and trouble taken by yourself. It is not often that one sees service like this from the larger companies."
L.T. Stradbroke, Vic

"I wish to congratulate you on your prompt and courteous service and I look forward to further purchases".
W.A. Kondinin, WA

"Thanks for the last order. You took a few days — (who reckon they are no 1) took a few weeks!"
B.H. Mossman, Qld

"Thanks to your speedy service I received the goods sooner than you realised!"
M.K. Mt Isa, Qld

"Many thanks for your efficient and courteous service."
M.F. O'Connor, ACT

"Thank you again for your prompt service."
R.S. Rylstone, NSW

"Thank you very much for all the trouble you went to. It has been very much appreciated."
T.O. Auckland, NZ

"Thank you indeed for your excellent Mail Order Service."
D.C. Brisbane, Qld

"Thank you for your letter and the advice it contained. I appreciate that advice".
T.R. Balnarring, Vic

and here's why we're No 1:

Over the years we have seen numbers of small electronics retailers try to turn their hand to mail orders: and after just a few orders they're suddenly justified in claiming they're 'number one'.

We have a few people who would disagree: over 350,000 in fact. For that is the number of people who have placed their trust in the company they **know** is number one: Dick Smith Electronics.

In the interests of fair competition, we'd like to pass on a few tips from our sixteen years of experience:

- Stop using hand written invoices covered with illegible scrawls. Instead, invest half a million dollars in an IBM System 38 Computer with a team of programmers, 12 months planning and finally an 'on-line' mail order department. Clear, concise and detailed information - what the customer wants. Just like we do!

- When customers send in too much money don't return a scrap of paper in their order with the amount on it. They could lose it! Instead, use your on-line

system to itemise any credit on the invoice and then **automatically** deduct it from the next order.

- If you run out of stock don't just scrawl 'out of stock' on the order. Put it on back-order, inform the customer of the delay and check all back-orders daily until the stock arrives. When it does, post it out at no extra charge. It's expensive, but it's the type of service you should offer. Just like we do.

- Support your mail order department with at least \$5 million worth of stock and surround with 150 skilled people all geared to provide the customer with the best possible service. Just like we do.

- Ensure that you despatch all orders within 24 hours of receipt: no-one wants to sit around waiting weeks for the goods to arrive. If there must be a delay, tell the customer why. Just like we do.

- And occasionally when you make a mistake - and you will (you're only human) be strong enough to admit it. Just like we do.

DSX PRESS
DICK SMITH ELECTRONICS EXPRESS ORDER SERVICE

others promise delivers.

Why not try it for yourself ?

24 HOUR DESPATCH

DSX PRESS
DICK SMITH ELECTRONICS EXPRESS ORDER SERVICE

ORDER FORM

PO BOX 321 NORTH RYDE, NSW 2113 Phone Enquiries: (02) 888 3200
16 YEARS RELIABLE MAIL ORDER SERVICE

Name Address

Postcode Tel. No

Have you changed your address?

Have you bought by YES if so please print previous address here
Mail Order before? NO Date

VISA PAYMENT: Cheque Money Order VISA Bankcard Mastercard Expiry Date

 Signature

Cat. No.	Qty.	Description	Item Price	Total Price

Delivery Instructions (Please tick)

Post & Packagina

For goods sent by standard mail

- Standard
- Airmail
- Registered

(Add \$3.50)
ORDER VALUE
\$ 5.00-\$9.99
\$10.00-\$24.99
\$25.00-\$49.99
\$50.00-\$99.99
\$100 or more

IN A HU

SPECIAL OFFER
February only
FREE
air freight
anywhere in Australia.

Merchandise Total:	
Pack & Post/Freight:	
(Registration):	
SUB TOTAL:	
Less Credit:	
TOTAL \$	

MINIMUM ORDER \$5.00

14 DAY MONEY-BACK GUARANTEE

Some time ago ETI was asked to review some NiCad batteries by a local agent, Power Sonic. Well, that is a bit of an odd request, and not one which can be done quickly, it turns out. Nevertheless, here is the result, and we trust that it is informative.

Jonathan Scott

“POWER TO THE PEOPLE”

WHAT ARE THE most interesting attributes of a battery? Well, some idea of the capacity of a cell (i.e: the actual amount of energy delivered per charge) is important. Also the span of the cell (i.e: the number of charges it will deliver before expiring) is important. These two are, of course, related, as will be shown, for the capacity varies with age, measured in time and usage. In addition some measure of how much punishment a cell will take would be informative. Availability of the less usual sizes and shapes is a final factor of concern to people who want custom cell configurations or whose gear does not use the ubiquitous 'penlite' (AA) cell.

The latter requirement is easily summed up, for Power Sonic offers a large range of cells: the standard penlite (AA) cell, C cell and D cell; the AAA cell which is thinner than the AA, the N cell which is both thinner and shorter, the 2/3AA which is not sur-

prisingly 2/3 as long as an AA; a cell called the 'SC', which is a short C cell (clearly) and a short D cell, you guessed it, the 'SD'. There are also the F cells, which are long D cells.

In addition to the above range of standard cells Power Sonic offers the C cells and the short C cells in a fast charge type, and AA, 1/3AA, SC, C and D cells in high temperature types. We reviewed only the standard sorts, so we cannot make any comments on the special types mentioned last.

Cells can be purchased by OEMs in any configuration required, all welded together and encapsulated on heatshrink envelopes, if so desired. This facility is very useful for manufacturers who wish to minimise bad connection problems and/or prevent accidental mixing of old and new cells in their equipment, etc. Certain cell combinations are available with PCB mount connections intended as memory backup cell packages.

While this is probably of little interest to individuals, it at least indicates some serious commitment on the part of the local people.

Capacity

Initially we verified that the cells delivered their quoted capacity. This they all did, with some in hand. The capacity of a battery is usually measured in Ampere-hours, or Ah. For a moment let us measure in milliWatt hours per cubic centimetre (mWh/cm³) which is a method more often used to compare batteries of various types, because it reflects the energy stored per unit volume. The PS cells were quoted as having between 50 and 85 mWh/cm³, which is pretty standard. It rises from the minimum with the smallest cells, because they have a lot of case per unit of active ingredients, to the maximum with the F and D cells, which are pretty hefty and have a lot of insides for the case. By way of comparison, a lithium cell

Figure 1. Life of an AA cell at the 2 C rate.

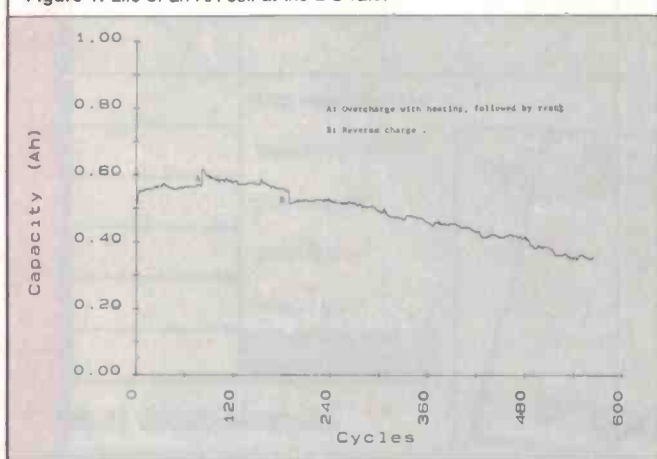
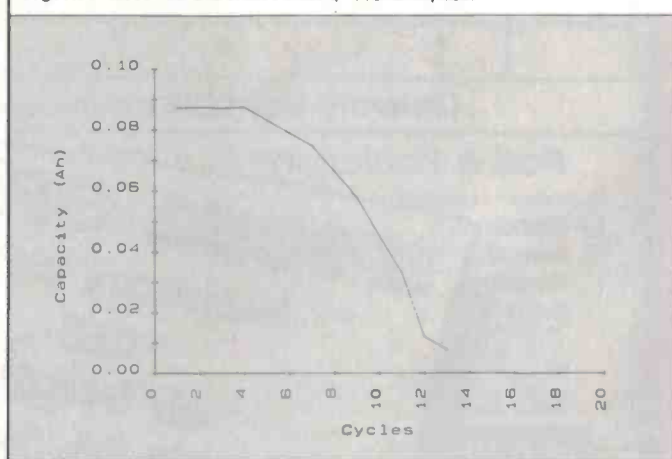

Figure 2. Destructive test of a 1/3AA, 110 mAh, cell.



POWERSONIC NICADS

Distributed by: Powersonic, Shop 43, 61-89 Buckingham St, Surry Hills NSW 2010. (02)699-2722.

Prices:	AA (500 mAh)	\$3.30
(r.r.p.)		
(inc. tax)	C (2 Ah)	\$9.40
	D (4 Ah)	\$15.90

might have as much as 800 mWh/cm^3 (the spec for Hellensens cells, 1983), while a sealed lead acid type offers typically up to 55. The PS AA cell we tested first was specified as offering 70, but delivered 80 mWh/cm^3 . (All the tests, we should note here, were carried out in a room at 25°C , at the 10 hr rate, unless specified otherwise.)

Back to familiar Ah. The 500 useful charges which you may see quoted in advertisements for NiCads seemed to us to be very optimistic. If a penlite cell was to be charged and discharged at the recommended rate (14 + 10 hrs) this lifespan represents 500 days of continuous testing. Even ETI's enthusiasm does not stretch to over a year and a third per cell. It was thus decided to do only a couple of cells, and to both charge and discharge them at a fast rate — say 1 amp. This represents really working them hard indeed! The results are shown in Figure 1. Ignoring the small variations, it can be seen that the cell started at just over the 500 mAh quoted, rose to about 600 mAh, and did not fall to 500 again until about cycle 300. The average capacity (the integral under the curve) did not fall to 500 mAh until almost 500 charges (at the accelerated rate!) had elapsed. We have not done this to another brand for comparison, but we figure it is pretty good. The small aberrations in the figure will be discussed shortly — they have been deliberately included to indicate certain responses to abuse. Cells not subjected to the odd circumstances produced similar results to the one whose graph is shown.

Thrashing!

Next we decided to see what kind of thrashing a cell can take. We noted in the literature that cells below C-size could take fast charging, by which the manufacturer means



Bolled. The 1/3AA cell destructively tested lost its 'innards' harmlessly via the end seal.

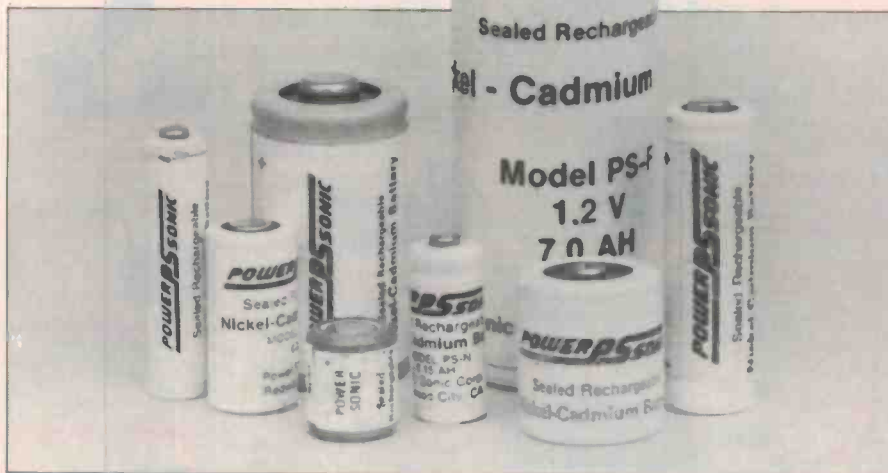

about double rate. We had run the penlite at the 2 C rate, which means it would be expected to discharge in half an hour if it were ideal. Ratings usually assume the C/10 rate, or discharge over 10 hours; 2 C is 20 times overspeed already. Although we did not do a comprehensive test (that is, work the cell to complete death) we noted no serious deterioration over tens of charges at 4 C. At 10 C, however, a cell overheats. It appears to be as we suspected — it is the heat that boils the internals and breaks the seal which brings about the demise of a cell. At 10 C a PS-1/3AA, rated at 110 mAh, died quickly, exuding its lifeblood swiftly but harmlessly. So we have verified (in limited trial) that the cells will run quite happily at 2 C, or twenty rated, but that they will die by overheating at 10 C.

It should be noted here that the cells are rated up to 45°C charging and 65°C discharging. The lower charging temperature is because more power is dissipated when charging. When nearing full charge the cell dissipates what energy it cannot assimilate as heat, requiring greater dissipative capability for the same internal temperature.

Thus the above operation at 2 C has assumed that you will be careful not to overcharge the cell. What does happen if the cell is overcharged by a factor of two, provided that the seal is not badly ruptured and the contents escape? What happens if the cell is discharged to less than 0 volts, such as might happen if one cell in a stack has less capacity than the others, and is reverse charged by the others still discharging? These two conditions were simulated on the cell whose 'lifeline' is pictured in Figure 1.

At the point marked A, or rather between the discharge capacity plots at either end of the short jump, the cell was doubly charged and rested until quite cool (overnight). Its temperature exceeded 60°C , but did not give indication of gassing. As you may see from the graph it exhibited elevated capacity for some charge cycles af-

terward. The capacity fell back to about where it was expected to have been in 10 to 20 cycles. How the cell appears to have held some of the excess, we are not sure.

The cell was only discharged until the terminal voltage fell to .9 V at 1 A load, so a small increase in resistance could have masked some charge retained. Alternatively, the cell may have suffered some beneficial restructuring of its electrodes. In either case the cell returned to its former self. (We favour a mixture of the above reasons. We cannot eliminate the second because we are quite sure that the cell was being fully charged at each charge phase. Also the rest may have been the beneficial factor, rather than overcharging.)

At point B the cell was reverse charged about 20% on one C. Again the effect lasted some charges, but this time it was such as to deplete the apparent capacity. Again the cell returned to being its former self. This indicates a fairly acceptable response to mild abuse, as so often arises in the daily use of, say, batteries in a portable appliance.

The final point of interest is the continuous array of 'noise' on the curve of Figure 1. We kept the temperature of the test room constant, and the current and times were set to within 5 mA and 14 seconds. There is clearly some other factor for which we were not controlling. We have honestly no idea what it might have been, but we are likewise sure that you will not be controlling for it either, so it does not matter greatly — the curve represents what you might expect.

In summary, though we have no good reference with which to compare the performance, it was most satisfactory in our opinion. A cell rarely gets used to the end of its natural life in our erratic and experimental environment, so the tests are not representative of what we would expect from a cell, but can be taken as good representative data for a cell used carefully and regularly in a cassette player, provided it is charged according to requirements, etc. ●

NEW!!

ALARM PRODUCTS!

- ALARM CIRCUIT FOIL TAPE**
Cat. S15080 \$7.95
- ALARM CONTROL MODULE**
Cat. S15055 \$29.95
- MINI BUZZER 5-15V WHITE/BLACK**
Cat. S15062 \$1.95
- PIEZO ALARM SINGLE TONE**
Cat. S1506 \$6.95
- PIEZO ALARM DUAL TONE**
Cat. S15070 \$7.95
- D.C. BELL 4" 12V 250 MA**
Cat. S15072 \$9.95
- HEAT SENSOR**
Cat. S15074 \$9.95
- MAGNETIC READ SWITCH N.O.**
Cat. S15057 \$2.50
- MAGNETIC READ SWITCH N.C.**
Cat. S15058 \$2.95
- SHOCK/VIBRATION SENSOR**
Cat. S15049 \$2.95
- GLASS BREAKAGE SENSOR**
Cat. S1505 \$3.95
- LOCAL BURGLAR ALARM CONTROL PAN**
Cat. S15051 \$69.96
- ULTRASONIC BURGLAR ALARM**
Cat. S15052 \$80.95
- ULTRASONIC MOTION DETECTOR**
Cat. S15033 \$39.95
- KEYLESS AUTO ALARM 12V**
Cat. S15054 \$39.95
- WALL BRACKET TO SUIT S15052**
Cat. S15042 \$11.95



DIGITAL MULTIMETER
YFE YF1100 FEATURES

- Large easy to read 3 1/2 digit display
- Facilities for transistor and diode testing
- Clearly laid out front panel
- 10A DC AC range
- Priced to undersell the others!

Cat. A16025 \$59.50



QUARTZ CRYSTAL CLOCK MOVEMENT

- Very compact and reliable
 - Self starting one second stepping motor has strong torque
 - Powered by 1.5V AA battery that lasts for a year
 - Supplied with two sets of hands, one short and one long
 - ~15 seconds/month accuracy
 - 56mm square, 15mm deep
- Complete with data sheet, instructions and wall hanger bracket

Cat. XC0100 \$14.95



ELECTRET MIC INSERTS

- With pins for easy board insertion.
- 1+ 10+ 100+
- \$1.25 \$1.10 \$1.00



NATIONAL RECHARGEABLE DRILL/SCREW DRIVER E2505

- ★ Quick 1 Hr Charging
 - ★ 4 Stage Torque Control
 - ★ 2 Speed Switch
 - ★ Handle Storage Compartment
 - ★ Forward/Reverse Operation
 - ★ National Quality
 - ★ Spare Battery Pack Available
- Cat. T12320 \$149.00



PUSH BUTTON DIALLERS

Tired of old fashion dialling and re-dialling engaged numbers? These convenient push button diallers include last number redial (up to 16 digits) and instructions for an easy changeover.

Cat. A12030 \$19.95



COLOUR CAPPED KNOBS

- Economy knobs with elevated white pointer
- Cat. H10001 RED
Cat. H10002 BLUE
Cat. H10003 GREEN
Cat. H10004 YELLOW

This month's prices

1-9 10-99 100+
\$0.40 \$0.35 \$0.30



2K OHM MULTI METER

11 Ranges, pocket size.

- SPECIFICATIONS:**
- 11 RANGES
DC VOLTAGE: 0-10-50-250-1000 volts 2000 ohms/volt
AC VOLTAGE: 0-10-50-250-1000 volts 2000 ohms/volt
DECIBELS: -10 to +22dB in four ranges
OHMMETER: 0-10 kohms, 0-1 mega-ohms
DC CURRENT: 1-100mA normally \$14.95 this month \$9.95



S100 PROTCARDS SAVE \$10 This month only.

- Cat. H19125
- Horizontal Buss** Cat. H19125 \$29.50
- Vertical Buss** Cat. H19130 \$29.50
- Pad Per Hole** Cat. H19135 \$29.50



TRANSISTOR NIPPERS
Normally \$7.95 This Month \$6.95
Cat. T12070



MICRO NIPPERS
Normally \$9.95 This Month \$6.95
Cat. T12050



MICRON SOLDERING IRON

240V, 30 W general purpose for electrical and electronic soldering.

Cat. T12430 This month \$10.95



UNIVERSAL SOLDERING IRON STAND

Cat. T11302 \$5.95 slashed to \$3.95



VIDEO RF MODULATOR

At an unbelievable price! Our RF modulators are channel selectable either Channel 0 or Channel 1

1-9 10+
Cat. S12500 \$4.95 \$3.95



KEY SWITCHES

1-9 10+
Cat. S12500 \$3.95 \$3.75



TAPERED REAMER

Great for enlarging holes that are a bit too small. Enlarges from 5mm to 20mm

Cat. T12370 \$6.95



FAIRCHILD TTL DATA BOOKS

Just arrived! This book is the same as used in the Victorian Education System. Includes data on new Fast series. Limited stock 500 only.

Cat. B10050 \$14.95



POWERFUL MINI DRILL

Featuring a powerful 6000 r.p.m. motor, this lightweight 113gm drill is ideal for many jobs. Perfect for PCB work. Has a 0.8 to 1.2mm chuck and 1mm drill bit. Requires 12V 1 AMP (use with M19010)

Cat. T12302 \$11.95



PANEL METER BARGAINS!

250 uA Sensitivity Panel cut out 36 x 16mm Mounting hole centres at 49mm

Cat. O10400 normally \$4.50 this month \$2.95



RITRON (ZETA) DATASETTE

For data loading and saving. This Micron Datasette suits most home computers and features tape counter, monitor function for audio verification and slide volume control for output level.

Cat. C14900 \$29.95

NEW!!

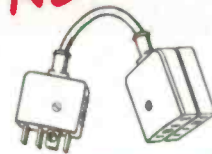

TELECOMMUNICATION PLUG TO 2 SOCKETS.

Ideal for modem connections.
Cat. Y16014 \$12.95



TELECOMMUNICATION PLUG/SOCKET
Plug Cat. Y1601 \$3.95
Socket Cat. Y16018 \$4.95



TELECOMMUNICATION EXTENSION LEADS
Cat. Y16010 5m \$12.50
Cat. Y16012 10m \$14.95



BREADBOARD SPECIALS

Why pay more??

- | Competitors Price | Our Price |
|------------------------------|-----------|
| Cat. P11000 100 holes \$2.95 | \$1.50 |
| P11005 640 holes \$4.95 | \$5.95 |
| P11009 840 holes \$14.85 | \$10.95 |
| P11012 1680 holes \$27.95 | \$19.95 |
| P11015 2400 holes \$45.00 | \$29.95 |



TO3 HEATSINK

1-9 10+ 100+
\$1.00 \$0.90 \$0.75



NEGATIVE & POSITIVE CIRCUIT RESIST

Make your own presensitized PCB Boards. POSITIVE PHOTO RESIST for using 1-1 tapes and pads on clear film for one off or prototypes. Resist 50ml bottle for approx. 1500 sq cm of pcb

Cat. P85500 \$6.95

DEVELOPER: 70 gms of crystals to mix with 211 of water, enough to complement 50ml of resist.

Cat. P85504 \$3.25

NEGATIVE PHOTO RESIST for using normal negative PCB images. Resist 50ml bottle for approx. 1500 sq cm of pcb

Cat. P85508 \$5.45

DEVELOPER 500ml bottle enough to complement 50ml of resist. No dilution required

Cat. P85510 \$8.50

ETCHANT 400gms of crystals to mix with 1 to 1 1/2 lts of HOT water

Cat. P85512 \$3.25



ELECTRONIC CASSETTE DEMAGNETISER

Save \$2. Rec. retail \$19.95
Cat. A10006 This month \$17.95



P.A. SPEAKERS

Dual cone, wide range, 200mm (8 in.) 10 W Ideal for public address, background music etc.

1-9 10+
Cat. 1200 \$9.50 \$8.50



CAR REPLACEMENT SPEAKERS

- Cat. C10757 5x7" Oval \$5.95
- Cat. C10746 4x6" Oval \$4.95
- Cat. C10705 5" Round \$4.50
- Cat. C10706 6" Round \$5.95

All are rated at 4 OHM, 5 WATT



MINI STEREO HEADPHONE

Low cost hi-fi sound! Light and comfortable, as easy to wear as hair!

Cat. C14000 \$4.95



3 1/2" MAGNIFYING GLASS

Ideal for close inspections of solder joints etc.

Cat. T12087 \$7.95



PIN VICE

It's infuriating when all you need to do is drill one hole a little bit bigger and haven't got a drill that fits in your tool box. Buy one of these for drilling circuit boards. Will hold drill bits, taps, files, etc up to 3mm

Cat. T12352 \$7.95



MAGNETIC BULK ERASER

The best and by far the quickest way to erase tapes, cassettes and computer discs! Reduces noise levels below recorders own erase head level. On/off switch located in handle. 240V AC operation

Cat. C14950 \$29.50



CANNON TYPE AUDIO CONNECTIONS

We've sold 1000's because of their great value!

3 Pin line male 1-9 10+
Cat P10960 **\$1.90 \$1.80**
3 Pin chassis male
Cat P10962 **\$1.90 \$1.80**
3 Pin line female
Cat P10964 **\$2.50 \$2.20**
3 pin chassis female
Cat P10966 **\$2.90 \$2.70**



BULK CABLE 100M ROLLS
Cat. W11222 3C2V75 OHM **\$22.00**
Cat. W11224 5C2V75 OHM **\$35.00**
Cat. W11219 4 Core Shielded **\$49.00**



MINI MODEM
300 baud full duplex
Answer originate
Plugs straight in (hardwired phone)
Superior VLSI chip performance identical to Multi Modem
Telecom Approval (C84/37/1173)
Incl phone only **\$199**

ALUMINIUM SHEETS .8mm
CAT. SIZE PRICE
H10770 150x150mm **\$1.75**
H10771 150x300mm **\$2.50**
H10772 300x300mm **\$3.95**
H10773 300x600mm **\$6.90**



HEX KEY PAD
19 Keys, Unencoded, 76 x 95mm
Cat. K46804 **\$42.50**



RECHARGEABLE 12V GELL BATTERIES
Leakproof and in 3 convenient sizes, these long service life batteries are ideal for burglar systems, emergency lighting or as a computer backup power supply. Ideal for many power needs.
Cat. S15029 12V 1.2 AH **\$17.95**
Cat. S15031 12V 2.6 AH **\$34.50**
Cat. S15033 12V 4.5 AH **\$44.95**



BLANK DATA CASSETTES
Brings out the best in any micro!
1-9 10-99 100
\$0.90
Cat. D11141

★★★ SCOOP ★★★

PRIME SPEC RED LEDS
We bought 100,000 so you can reap the benefits!
1-9 10+ 100+ 1,000+
10c 9c 8c 7c
Cat. Z10150



NEW SLOPING CASES
Plastic with metal front panel, available in two sizes.
Cat.H10450 **\$9.95**
190x120mm
Cat.H10455 **\$17.95**
265x185mm
(measurements are approx. only)

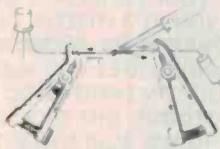

HEAT STOPPERS
For protecting parts which have little resistance against heat when soldering. Normally \$3.50.
Cat. T12440 **\$2.50**



RS232 & 'D' TYPE CONNECTORS
PART DESCRIP. CAT.NO.
1-9 10-25
DE 9P 9 Pin Female P10880 **\$1.75**
DE 9S 9 Pin Male P10881 **\$2.25**
DE 9C 9 Pin Cover P10882 **\$2.55**
DA 15P 15 Pin Male P10894 **\$2.10**
DA 15S 15 Pin Female P10895 **\$2.25**
DA 15C 15 Pin Cover P10892 **\$1.15**
DB 25P 25 Pin Male P10900 **\$2.95**
DB 25S 25 Pin Female P10901 **\$3.45**
DB25C 25 Pin Cover P10902 **\$1.20**



36 WAY CENTRONICS CRIMP PLUG
Cat. P12200
1-9 10-99 100+
\$6.50 \$5.95 \$5.50



SOLDER CENTRONICS PLUGS
Unreal price for absolute top quality. Normally \$14.95 (Our opposition charge up to \$19.95).
1-9 10+ 100+
\$6.95 \$5.95 \$4.95



CENTRE RETURN JOYSTICK
Features 2 x 150K pots, long shaft 40mm with 25mm control ball. Bonus adjustable offset feature on pots.
Cat. X1563/ 1-9 10+
\$9.95 \$8.95

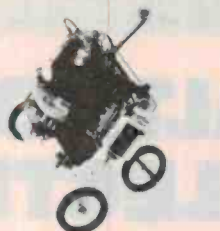

PIPER MOUSE ROBOT
This is a Super-Sonic robot, controlled by a super-sonic sound sensor and an electronic circuit. (1 channel). By using the whistle included with this Kit, Piper Mouse will obey your commands immediately turning to the left, stop, turning to the right, stop, advance and stop.
Cat. K96680 **\$34.95**



RELAY AND BASE
Can carry 10A at 28V DC or 5A at 240V AC. Supplied with Chassis Mounting Socket with screw terminals. Great for school projects and demonstrations, switching DC power supplies, central circuits and with contacts parallel up to 20A can be switched.
Normally \$8.95
Cat. S14074 **This month \$6.95**

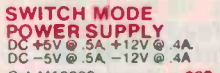

SWITCH MODE POWER SUPPLY
DC +5V @ 5A, +12V @ .4A
DC -5V @ 5A, -12V @ .4A
Cat. M16680 **\$89**

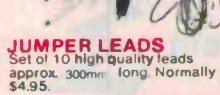

JUMPER LEADS
Set of 10 high quality leads approx. 300mm long. Normally \$4.95.
Cat. W12000 **\$2.95**



NICAID BATTERIES
Save on carbon batteries with these Apollon Nicaid cadmiums. Rechargeable up to 1000 times!
Cat. S150020 AA500 MA
Cat. S15021 C 1.8 AH
Cat. S15022 D 4 AH
1-9 10+
\$2.25 \$1.95 \$4.95 \$3.95 \$7.95 \$6.95



LOW PROFILE IC SOCKETS
How cheap can they go?
1+ 10+ 100+ 1000+
8 pin Cat. P10550
15c 14c **12c 09c**
14 pin Cat. P10560
16c 15c 14c **10c**
16 pin Cat. P10565
17c 16c 15c **11c**
8 pin Cat. P10567
18c 17c 16c **13c**
20 pin Cat. P10568
29c 28c 27c **26c**
24 pin Cat. P10570
35c 33c 32c **28c**
40 pin Cat. P10575
45c 40c 35c **30c**



APPLE JOYSTICKS
Ideal for games or word processing.
Fits most 6502 compatible computers
Cat. C14200 **\$24.95**



VERBATIM DISKS
"Lowest" price possible for "Highest" quality
1-9 10+ 100+
HD525-01 3.95 2.75 2.50
HD550-01 4.50 3.95 3.75



RELAY AND BASE
Can carry 10A at 28V DC or 5A at 240V AC. Supplied with Chassis Mounting Socket with screw terminals. Great for school projects and demonstrations, switching DC power supplies, central circuits and with contacts parallel up to 20A can be switched.
Normally \$8.95
Cat. S14074 **This month \$6.95**



ELECTRONIC CASSETTE DEMAGNETISER
Save \$2 Rec retail **\$19.95**
Cat. A10006 **This month \$17.95**



ECONOMY TOGGLE SWITCHES
Unbelievable Value!
1-9 10+ 100+
S11010 (SPDT) **\$1.00 \$0.90 \$0.80**
S11020 (DPDT) **\$1.20 \$1.00 \$0.90**

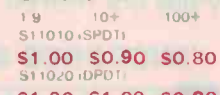

10,000uF 75V ELECTRO
25% more microFarads! Ideal for those who want a more powerful amp!
1-9 10+
Cat. R16587 **\$10.50 \$9.00**

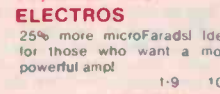

NEW JOINABLE PCB MOUNTING SCREW TERMINALS
Less than half the price of the old ones!
2 way 1-9 10+
Cat. P10542 **\$0.50 \$0.40**
3 way
Cat. P10543 **\$0.75 \$0.65**
(please note these are the new blue ones.)

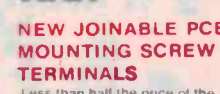

LOGIC PROBE 3800A
Features 20MHz, memory TTL CMOS operation. Normally \$29.50 now only
Cat. Q11272 1-9 10
\$19.50 \$17.50



INCREASE YOUR MEMORY
4116 1-8 10-70
4164 4.95 4.50
2716 6.25 5.95
2732 6.25 5.95
2764 8.25 7.95
27128 27.00 25.00
6116 6.95 6.75
41256 27.50 22.50
(256K)

BULK 'IC' SPECIALS
LM 324 10+ 100+ 1000+
LM339 \$0.70 \$0.65 \$0.60
LM555 \$0.40 \$0.39 \$0.35
LM723 \$0.60 \$0.55 \$0.53
LM741 \$0.45 \$0.40 \$0.37
LM1458 \$0.80 \$0.70 \$0.65
LM1488 \$0.60 \$0.57 \$0.55
LM1489 \$0.60 \$0.57 \$0.55



PHILLIPS SPEAKER SPECIAL
Cat. C12030 AD01610 T8 **\$12.95**
Cat. C12040 AD02160 S08 **\$34.95**
Cat. C12045 AD70620 M8 **\$49.00**
Cat. C12050 AD12550 W8 **\$79.00**
You don't have to "imagine" Phillips quality at these prices!



SUPER HORN TWEETER
Wide dispersion tweeter handles up to 100W!
Sensitivity 105dB/0.5m
Frequency Response 3KHz-30KHz
Impedance 8 OHMS
Size: 145x54mm
Cat. C12103 **\$12.95**



SUPER HORN TWEETER
Requires no crossover and handles up to 100W!
Sensitivity 100dB/0.5m
Frequency Response 3kHz-30kHz
Impedance: 8 OHMS
Size: 96mm diameter
Cat. C12102
(Rec. Retail \$12.95) **\$11.95**

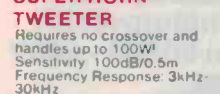

FULL STRENGTH FERRIC CHLORIDE
This month only!
250ml 1-9 10+
\$1.95 \$1.75
500ml **\$2.95 \$2.50**
1 litre **\$4.95 \$4.50**

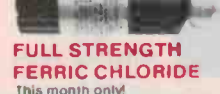

FUSE SPECIAL 3AG
Two values, 3 Amp and 1 Amp
1-99 100-999 1,000+
8c each 6c each 5c each
STOCK UP NOW

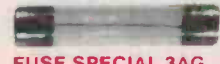

CAR ANTENNAS
We stock a wide range of car antennas including auto up/down antennas.



Rod Irving Electronics
425 HIGH STREET, NORTHCOTE VICTORIA.
Ph.(03)489 8866 489 8131
48-50 A'BECKETT STREET, MELBOURNE VICTORIA.
PH:(03)347 9251
Mail Order and correspondence:
P.O. Box 235 NORTHCOTE 3070

Call in at either 2 of our conveniently located stores:
48-50 A'Beckett St., Melbourne
425 High St., Northcote.
Or take advantage of our Mail Order Department.
Write to:

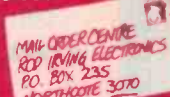

or phone ...
MAIL ORDER HOT LINE

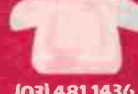

(03) 481 1436



POSTAGE RATES
\$1-\$9.99 **\$1.50**
\$10-\$24.99 **\$2.00**
\$25-\$49.99 **\$3.00**
\$50-\$99.99 **\$3.50**
\$100-\$199 **\$5.00**
\$200-\$499 **\$7.50**
\$500 plus **\$10.00**

Comet road freight is extra.



PROJECT ELECTRONICS
Here are 11 great projects for the beginner's from the ETI Project Electronics publication (5th Edition)
043 Heads of Tails **\$3.90**
044 Two tone doorbell **\$4.90**
047 Morse practice set **\$3.90**
048 Buzz board **\$4.50**
061 Basic Amplifier **\$5.90**
065 Electronic siren **\$5.90**
066 Temperature alarm **\$5.50**
067 Singing moisture meter **\$7.95**
068 LED dice **\$6.90**
072 Two octave organ **\$9.50**
084 Car alarm **\$13.50**
All these Kits are available from us at Rod Irving Electronics!
Cat. B1185 **\$4.75**
OR 'FREE!' with every order for 10 or more Kits!

1985 ALTRONICS ELECTRONIC COMPONENTS CATALOGUE

YOURS FREE with this month's Electronics Australia Magazine
OR send \$1 to cover P & P to Altronics, P.O. Box 8280, Stirling St., Perth, W.A. 6000

REMEMBER

Altronics staff are all keen young electronics enthusiasts — just like yourself — so when you need a little technical help, give us a call.

- ★ Quality Products at direct import prices.
- ★ Save up to 50% on our competitors prices.
- ★ Overnight delivery Australia wide.
- ★ Bankcard phone orders service to 8pm Mon-Fri.
- ★ Check some of the savings on our nearest competitors **1984** prices.

EXAMPLES



Why Pay \$6.50?



Why pay our nearest competitors \$13.95? Why Pay \$2.30?



STD FREE PHONE ORDER SERVICE

An Altronics 1st is our **INWATS Toll Free Order Line**. Bankcard holders can call us from anywhere in Australia for the cost of a local call and place your order; after validating your Bankcard, **presto** the order is on its way to you in a matter of hours. Remember with our **Overnight Jetservice** we deliver next day to capital cities and suburbs and 24 - 48 hours later to country centres. So if you're not already an Altronics Customer just pick up the phone and dial 008 999 007 and we guarantee to deliver faster than your local supplier.

FOR THE VERY QUICK!

Here are some incredible bargains. We suggest you phone order now to reserve yours.

IMPORT SCOOP

Quality Commonwealth Computer Fan 80MM - 240V



CAT F 1020

\$12

4 or More

\$11

Amazing Value

- ★ Super quiet ★ Sealed sleeve bearings for long life ★ Sturdy die cast frame ★ Operating range -10 deg C to + 70 C

ECONOMY RACK CABINET

- ★ Solid steel construction
- ★ Black anodised front panel
- ★ 3 unit (132mm)
- ★ Conforms to International Standards
- ★ Ventilated top and side panels



H 0400 ONLY

~~\$45.00~~

\$40

"MICROBEE KEYBOARD"



Full 60 Key Qwerty Computer Keyboard exactly the same type as has been used up to now with the famous Microbee Computer SPST keys Complete with mounting plate, all key caps etc Fully assembled Incredible value — Be Quick!

D1510 **\$19.95** ... ~~\$29.95~~

Microbee is registered trademark of Applied Technology Pty Ltd

SPEAKER 8 OHM 2 1/4 INCH



C 0610

1 - 9 10 - 99 100 up

\$1 90¢ 69¢

From 69¢

Stock Up Now and Save a Bundle



D Range Connectors all 1/2 Price



Be Very Quick This Month Only

WERE NOW

P 0880	DB 9	Male 9 Pin	2.50	1.25
P 0881	DB 9	Female 9 Pin	2.95	1.50
P 0882	DB 9	Male PCB Mnt	3.25	1.60
P 0883	DB 9	Female PCB Mount	3.95	2.00
P 0885	DB 9	Backshell Cvr	1.80	.90
P 0890	DB15	Male 15 Pin	2.95	1.50
P 0891	DB15	Female 15 Pin	3.50	1.75
P 0892	DB15	Male PCB Mnt	3.95	2.00
P 0893	DB15	Female PCB Mount	4.95	2.50
P 0895	DB15	Backshell Cvr	2.00	1.00
P 0900	DB25	Male 25 Pin	4.50	2.25
P 0901	DB25	Female 25 Pin	4.95	2.50
P 0902	DB25	Male PCB Mnt	4.50	2.25
P 0903	DB25	Female PCB Mount	5.50	2.75
P 0905	DB25	Backshell Cvr	2.00	1.00

Fluke Series 20

John Fluke Manufacturing has expanded its line of handheld multimeters with a new family of heavy-duty analogue/digital multimeters.

The new Fluke 20 Series, like the recently introduced 70 Series, combines a digital meter with an analogue meter. The 31-segment analogue bar graph makes measurements such as peaking, nulling and capacitor checking and provides an easy way to test for erratic or unstable signals.

To keep operation simple, functions are selected with a single rotary switch. High-speed auto ranging automatically selects the correct measurement range and positions the decimal point. Display annunciators clearly indicate range, polarity and any activated features.

According to the company, the new meters have been built to withstand the environmental and electrical abuse common to construction, maintenance, petrochemical and other heavy industries. They are guaranteed to operate in calibration for one year despite drops, shock, vibration, or water and chemical spills. All components are shock-mounted and safeguarded with high-energy fuses and extensive overload protection to prevent mechanical damage or electrical shock. In most overload circumstances replacement of fuses is not even required. Extensive shielding protects the meters from excessive electromagnetic interference.

A new liquid crystal display works at extreme temperatures. Operation is guaranteed from -15°C to $+55^{\circ}\text{C}$ and to -40°C for 20 minutes. Typical continuous operation is from -20°C to $+60^{\circ}\text{C}$.

The new 20 Series incorporates a new integrated circuit developed by Fluke exclusively for it.

The new chip improves overall accuracy and gives the meters a higher voltage capability with more current ranges. It offers 0.1% dc accuracy, 100 μV to 1000 Vac and dc, 0.1 μA to 10 A ac and dc; and 0.1 ohm to 32 M resistance. It can also measure up to 10 000 M with a con-



Series 20: The four new meters from Fluke.

ductance function and measure in-circuit resistance without turning on diodes or transistors.

A continuity beeper, assists wiring, diode and transistor checks.

The Software Touch Hold, first introduced with Fluke's 70 Series, has been further improved in the 20 Series. Using Touch Hold, the user can take readings of critical circuitry while watching the probes. Using standard test leads, the meter captures a stable measurement and locks the digital reading in the display for viewing. It automatically beeps and updates when a new stable measurement is established. The analogue bar graph continues to follow the input signal while the digital display is held between measurements.

Fluke has given considerable attention to operator safety for the high-risk environments for which these meters are intended. The 20 Series' built-in safety features include extensive overload protection, high energy fuses and case designed to protect the operator from voltages one thousand volts greater than

safety standards require.

The case is also constructed entirely from non-metallic materials with special recessed input jacks to accommodate safety-designed test leads.

For more information contact Elmeasco Instruments, 15 McDonald St, Mortlake NSW 2137. (02)736-2888.

Fibre optics catalogue

Now available from STC-Cannon Components is the latest Fibre Optics summary catalogue. Contents include sections on optical interconnection design, interconnection components, test instruments and in-

stallation equipment.

The Fibre Optic Summary Catalogue is available on request to STC-Cannon Components Pty Ltd, 248 Wickham Road, Moorabbin, Vic 3189.

NEW EQUIPMENT

New variable auto-trannies

Electromark has introduced a new series of variable auto-transformers suitable for any equipment which is controlled by voltage variation. The SD range covers power ratings from 500 VA to 200 kVA and motor driven models are also available for remote control operation.

The M-types, ranging from 500 VA to 10 KVA have been manufactured in Japan to Electromark specifications for Aus-

tralian use. Models up to 15A incorporate Australian standard output sockets and are fitted with input cords and plugs. A voltmeter is fitted as standard equipment and the larger models have a circuit breaker in place of the fuse.

For more information contact Electromark, 43 Anderson Rd, Mortdale NSW 2223. (02)570-7287.



Slide regulators: M-series regulators from Japan.

Programmable spectrum analyzers

According to the company, the new HP 6566B (micro-wave) and HP 8558B (RF) spectrum analyzers from Hewlett Packard have enhanced functions to process both incoming signals and traces as well as a set of command flow functions to make decisions like a computer.

More than 120 new functions have been added to the B versions of the HP 8566 and 8568 when compared to their A version predecessors. The signal-processing functions include Fast-Fourier Transforms and power-bandwidth calculation of incoming signals. Trace-processing functions include storing of the minimum value of a trace and finding the standard deviation of trace data.

Users of the new analyzers can define a set of front-panel keystrokes for a desired measurement routine. This set then can be stored in a single softkey, accessible either from the front panel or over HP-IB (Hewlett Packard's enhanced implementation of IREE-488). This capability simplifies manual and remote operation.

New functions like IF, THEN, ELSE, ENDIF, REPEAT and UNTIL allow the user to write complete measurement programs on the HP 8566B and 8568B that can be executed without an external computer. For production test, for example, a computer can load a 'command flow' program into several analyzers. The analyzers can then run a program as stand-alone instruments.

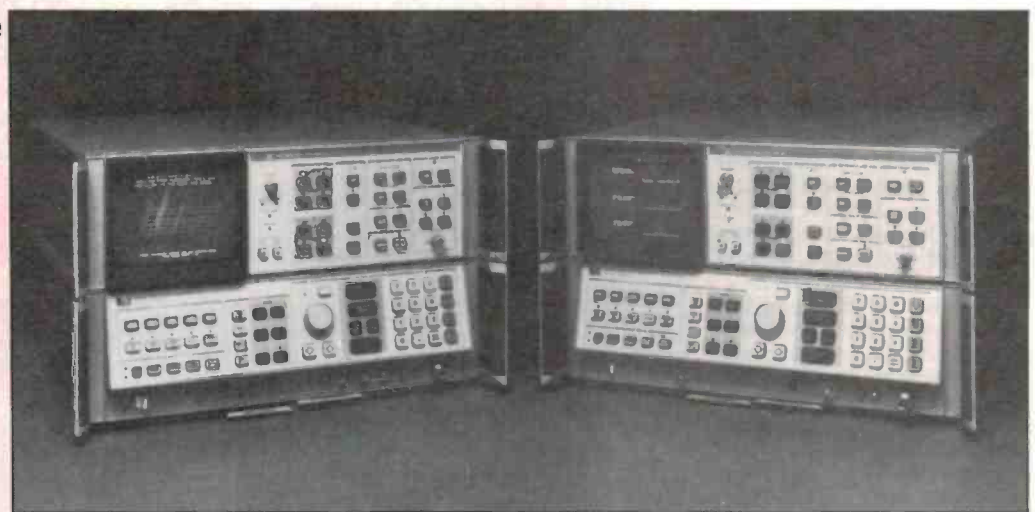

Looking at the Spectrum: Two new spectrum analyzers from H-P with advanced logic.

In an automatic test system, this enhanced internal processing through softkey access of routines and through command flow programs frees the system controller to devote more time to other measurement and processing tasks.

There is 16K of RAM available for storage of user-defined routines. The new analyzers can transfer a CRT display to an X-Y plotter without an external computer. This function can be executed from a front panel or over HP-IB. It can also store and plot more than eight full 1001-point traces or 80 compressed traces, also without an external computer.

Programs written for the HP 8566A and 8568A can run on the new B version analyzers. The HPL Pac and BASIC Library for the predecessor analyzers are directly compatible.

For more information contact H-P at 41 Joseph St, Blackburn, Vic 3130. (03)895-2895.

Low cost function generator

Parameters has released a new versatile signal generator that provides all the major functions of a standard generator plus a complete sweep generator capability.

Designated the TFG-4613 and manufactured by Topward Electric, the new generator can produce sine, square, triangle, \pm ramp, \pm pulse, am, fm, sweep trigger gate and burst waveforms over eight frequency ranges from 0.1 Hz to 13 MHz. Amplitude modulation frequency range is 0.01 Hz to 10 kHz to a depth of 100%. With an external source this range is extended to dc to 1 MHz.

Frequency modulation can be applied to the main waveform to $\pm 5\%$ over a frequency range from 0.1 Hz to 10 kHz and, once again, this may be extended from dc to 50 kHz

with an external source.

Frequency accuracy of the primary waveform is $\pm 5\%$ of full scale and distortion is less than 0.5% THD from 10 kHz to 50 kHz. Output is continuously variable from 1 mV p-p to 20 V p-p into an open circuit.

Sweep generator range is 100:1 on any range. The sweep is linear between start and stop frequencies set by the user. Sweep rate is variable from 0.1 Hz to 10 kHz.

The output frequency of the TFG-4613 may be varied by the application of an external voltage over a 1000:1 range. The frequency versus voltage curve is linear with 0.5% over a 100:1 frequency range.

For further information please contact Parameters Pty Ltd, P.O. Box 573, Artarmon NSW 2064. (02)439-3288.



ELECTRONICS TECHNICIAN GRADE III

SYDNEY OPERA HOUSE

Position No. S 425

SALARY:

\$20720 range \$21143 per annum.

QUALIFICATIONS:

Essential: Thorough knowledge and experience of television, analog and microprocessor systems. Electronics and Communications, TV Operators or equivalent certificate. Ability to construct electronic projects and good colour vision.

Desirable: Experience with professional TV and Audio systems and a knowledge of microprocessor applications.

DUTIES:

Maintain and construct video, audio and microprocessor equipment.

CONDITIONS:

40 hours per week, non-continuous shift work for which appropriate penalties will be paid. Four weeks annual leave. Superannuation benefits (subject to certain conditions).

INQUIRIES:

(02) 20588 ext. 271 (Mr G. Wilson).

Application forms may be obtained by phoning the Employment Officer, Sydney Opera House, Bennelong Point, Sydney on (02) 2-0588 and are to be returned to this office by Friday, 1 March, 1985.

SWANN ELECTRONICS INTERNATIONAL PTY. LTD. PROUDLY INTRODUCE OUR NEW 79 SERIES PUSH BUTTON SWITCH



PROUDLY
AUSTRALIAN
MADE

Features Include

- Compact styling
- SECV approved 10 amp 240 volt
- 4.8 mm QC terminals
- DPST latched or momentary switching
- Illuminated versions available in 240V, 110V, 24V, or 12V
- Printed legends suitable for many applications

Available from:

**SWANN ELECTRONICS
INTERNATIONAL
PTY. LTD.**

Melbourne (03) 544 3033
Sydney (02) 807 1944
N.Z. (9) 444 3620

COMPONENT SPECIALS

Memory

- 4116 RAM \$1.10
 - 4864 RAM \$3.90
 - 2732 EPROM \$4.90
 - 2764 EPROM \$6.95
 - 6116 Static RAM \$4.95
- (Min Qty of 10)
(Ring for Qty's Over 100)

Diskettes

- Datatype SSDD \$24.50
- Datatype DSDD \$29.50
- Boxes (10) in plastic boxes
- Data Parts SSDD \$19.50
- Boxes (10) in plastic boxes

Disk Drives

- Chinon 051D Drive 5 1/4" SSDD Low Power Consumption Slim Line \$129.00 (*that's right*)
- As above but double sided: (IBM compatible) \$199.00

Printers

- DT/BMC 100 100 CPS, F/T Feed New Model \$270.00
- DT/BMC 80 \$249.00

Disk Containers

- DX50 holds 50 diskettes \$14.00
- DX85 holds 85 diskettes \$18.00
- Lockable Security Boxes

- Amust P88/2 (super 5) with external NLQ switch F/T Feed, 120 CPS (min) \$325.00
- Epson Printers
Phone for best price in Aust.

Monitors

- Kaga Hi Res. Green or Amber Model 1203A or G. Suits most systems \$139.00 (*can you believe it*)
- Kaga Vision-Ex Colour Monitor. Accepts RGB or Composite Video. Excellent Quality \$389.00

Phone for your price on full range of Kaga/Taxan

- Apple Compatible drives. Atlas or Teac \$139.00

Phone for best prices in Australia on printer cables Incl. "IBM, Microbee, Commodore"

Freight \$4.00 Anywhere in Australia. All prices exc. tax. Add 20% if applicable.

DATA PARTS

11 Edward Street Shepparton 3630
Phone (058) 21 7155

Also at: Bendigo (054) 43 4866
Ballarat (053) 31 3399
Wagga (069) 21 6466
Albury (060) 21 8080
Melbourne (03) 336-1845



Disco World Pty. Ltd.

300 Main Street, Lilydale
P.O. Box 509, Lilydale 3140
(03) 735-0588

AMPLIFIERS

ZPE Series II (500W) \$1300.00

DISCO MIXERS

Citronic SM 330 \$695.00
Arista \$330.00

JUMBO STROBE

FLA 701 \$153.48
Scanner S101 \$99.45
Scanner Bar S104S \$342.86

HELICOPTER

2 ARM Spinner \$198.00
4 ARM Spinner \$289.00
8 ARM Spinner \$497.89
UFO 324 \$1698.55



PINSPOT

PS 112S \$48.94
PS 112L \$58.99



MIRROR BALLS

MB 008-8" \$37.20
MB 012 \$64.58
MB 014 \$93.54
MB 018 \$125.34
MB 020 \$153.79

SMOKE MACHINE

Great for Special Effects \$328.00

MIRROR BALL MOTORS

AC 240V \$29.99

ROLLING LIGHTS

8 x 4515 lamps \$958.95
24 lamps horizontal \$1985.45
24 lamps vertical \$1985.45

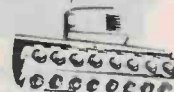

COSMOS LIGHT

24 lamps \$1980.68
Half Ball rotary light
6 lamps \$357.28



LAMPS all colours, soft glass

ES 240V 60W
box of 25 \$75.00
BC 240V 40W
box of 100 \$77.00
BC 240V 25W
box of 100 \$75.00

Bankcard & Mail Orders
Power Cords not included
Trade Enquiries Welcome
Send S.A.E. for free price list

SUPER FEBRUARY

SENSATIONAL PRICES ON 5000 AMP-SYSTEM KITS

Check the SPECIAL PRICES for the famous ETI 5000 series deal of a lifetime.

FAMOUS JAYCAR "BLACK MONOLITH" SERIES AMP - NORMALLY \$319.00

THIS MONTH **\$295** **SAVE \$24**



For further savings check the package deal below

FAMOUS JAYCAR "BLUEPRINT" 5000 SERIES PREAMP - NORMALLY \$299

THIS MONTH **\$265** **SAVE \$34.00**



Check below for package price FURTHER savings!

FAMOUS JAYCAR 1/3 OCTAVE GRAPHIC EQUALISERS! (5000 SERIES) NORMALLY \$199 EACH

THIS MONTH

2 FOR \$300!!



For FURTHER savings check

***** THIS SPECTACULAR PACKAGE DEAL *****

PACKAGE DEAL No. 1

Buy the 5000 Black Monolith Power Amp and 5000 Blueprint Preamp TOGETHER for only \$498!

That's right, save over \$120 on normal prices or over \$60 if bought separately from this months SPECIAL prices!

PACKAGE DEAL No. 2

Buy the following:

Power Amp 5000 "Black Monolith"	NORMALLY \$319.00
Preamp 5000 "Blueprint"	\$299.00
Graphic 5000 Equalisers (2 off)	\$398.00
	NORMALLY \$1016.00

THIS MONTH YOU GET THE LOT FOR

ONLY \$699!!!

THAT'S A MASSIVE SAVING OF \$317 (i.e. YOU VIRTUALLY GET THE "BLACK MONOLITH FREE) EVEN AT THE SPECIAL INDIVIDUAL PRICES IN THIS AD IT IS STILL A MASSIVE SAVING! - Special freight deal: anywhere in Australia \$12!! REMEMBER! WE TAKE NEARLY ALL THE CREDIT CARDS & FINANCE CAN BE ARRANGED ON THE SPOT.

February is BUY A JAYCAR CAR KIT

TRANSISTOR-ASSISTED IGNITION.

"Electronics Aust." All parts inc. die cast box Included!!! Hall-Effect type

cat. KA1505. Normally \$36.95 **FEB \$29.50**

Breaker points type cat. KA1506 Normally \$35.00 **FEB \$28.50**

Hall-Effect points installation

kit. Fits most cars (except Aust. 6's or V-8's). 90% of

European, 60% of Japanese. Send for a list or return unit for full refund if it does not convert your distributor into a breakless unit! cat. KJ6655 - Normally \$29.95 -

NOW \$19.95



MOTORCYCLE INTERCOM Ref: EA Feb '84 Talk to your friend while riding with your helmets on with this handy gadget. Why didn't someone think of it before (kit contains all specified components). Cat. KA1533 Normally \$39.95 **FEB ONLY \$35.**

"PHONY" PRODUCTS??

These products are more "Phony" than "Phony." And why? Because Jaycar gives you the greatest range of Phone accessories & components at the best prices!

TELEPHONE PLUGS & SOCKETS

Cat. PP1400 Standard line plug only \$2.95 10 up \$2.45

Cat. PP1410 Line or Surface Mount Socket. Only \$3.95 10 up \$3.50

TELEPHONE CABLE (Solid colour coded conductors)

Cat. No. WB1602 2 pair (4 wire) Only \$0.50/Metre 100M \$0.45/M

Cat. No. WB1603 3 pair (6 wire) Only \$0.70/Metre 100M \$0.65/M

Cat. No. WB1610 10 pair (20 wire) Only \$1.50/Metre 100M \$1.20/M

All telephone cable covered in standard cream outer sheath.

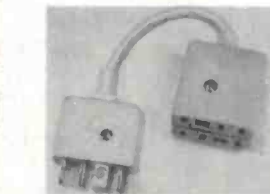

- MAKE YOUR OWN EXTENSION LEADS & SAVE!!

Jaycar ELECTRONICS

ROTARY TELEPHONE DIALS

Brand new dials surplus to requirements from a famous local manufacturer. They are very high quality, with governor & contacts fitted. Ideal for telephone enthusiasts. 1000's of uses e.g. combination code etc. Cat. YT6900 **\$2.95 SELLING FOR \$4.95** elsewhere.

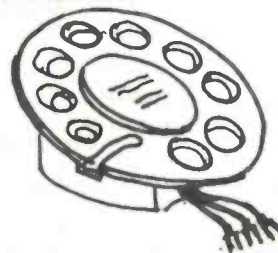

Built-up 'phone leads

5 & 10 metre leads are fitted with high quality stranded wire cables featuring thick sheath wall & secure termination. Will work with PABX's etc. & are suitable for heavy commercial use. The 15 & 20 metre cable is supplied on an attractive telephone-shaped wind-up reel & the double adaptor is just that - plug two 'phones into the one socket.

Cat. YT6010 5M LEAD NOW \$12.95

Cat. YT6012 10M LEAD NOW \$15.95

Save \$4.00

Cat. YT6018 15M LEAD NOW \$14.95

Save \$5.00

Cat. YT6014 20M LEAD NOW \$22.95

Cat. YT6020 Telephone Double adaptor \$12.50

SPECIALS

....the desperation continues!!

CAR MONTH! THIS MONTH AND SAVE!

ARE WE BALMY? IS THE SUMMER SUN GETTING AT US?

This month you can grab the KJ-6655 Hall Effect kit for wait for it - ONLY \$19.95! That's right! \$10 off normal low price!

**NOW SAVE \$10
ONLY \$19.95**

HALL EFFECT SWITCH VANE INTERRUPTED



PCB to suit
84T19
\$3.45

**NORMALLY \$19.95
THIS MONTH \$16.95**

If you have a car that won't take the Jaycar KJ-6655 Hall Effect Kit (i.e. an Australian six or VB) this could be for you! It is the SIEMENS (German) made Hall Switch. It will operate from -30 to +130°C. A simple soft iron vane cut with appropriate slots will commutate the unit.
Cat. HK-2101

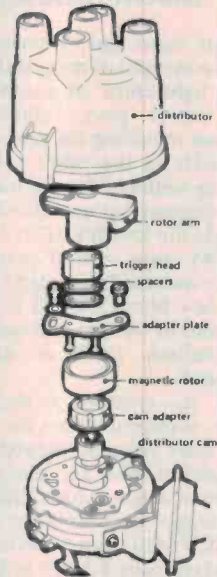

Monitors Slashed

Popular Green & Amber screen monitors. Glare & non-glare.

Cat.	Normally \$199	This Month \$169	Save \$30
Cat. XM4505 Green Standard			
Cat. XM4500 Green Screen (Non-Glare)	\$219	\$189	\$30
Cat. XM4504 Amber Screen (Non-Glare)	\$229	\$199	\$30

Tilt/Swivel Base For Monitors **NOW \$19.95**



SANGUINE BATTERIES?

We now stock a range of imported Carbon-zinc HEAVY DUTY batteries. They are well made & we think as good as the well known brands. Our brand? The world famous HI-WATT of course! We are so confident that you will be delighted with these batteries we have a special promotion at subsidised low prices. Check the prices below & compare what you are paying for 'Name' batteries. Sale is limited to two packs per customer.

Cat. No.	DESCRIPTION	PROMOTION PRICE
SB2340	"AA" Cell Pack of 4	0.89/Pack
SB2341	"C" Cell Pack of 2	0.75/Pack
SB2342	"D" Cell Pack of 2	0.95/Pack
SB2344	"AAA" Cell Pack of 4	0.69/Pack

Note: (i) They are better than the standard blue & white Hi-Watt battery.
(ii) They are blister packed for your protection.

NEW EA KITS!

See our ads in EA this month for details of our new 100CW/CHAN INTEGRATED AMP KIT, 30V1A variable power supply & Multi-Sector Burglar Alarm.

ARE WE FAWLTY?

WE'RE DOING IT ON PIANO KITS TOO!

FAMOUS JAYCAR "LYREBIRD" 73 & 88 NOTE PIANOS AT THE LOWEST COST EVER

Even lower than our low, low prices in September last year. We are phasing these kits out now for new lines in '85. They are still technically superior to many more expensive ready-builts AND have better tone, touch sensitivity etc for FAR LESS MONEY.

73 NOTE: NORMALLY \$475
ON SPECIAL LAST SEPT. \$375
THIS MONTH \$325
SAVE AN ASTOUNDING \$150!!

88 NOTE: NORMALLY \$589
ON SPECIAL LAST SEPT. \$425
THIS MONTH \$399
SAVE AN UNBELIEVABLE \$190!!

Remember each kit is the same quality as our normal kits. The kits contain a stand (similar BUT NOT THE SAME) as the one shown in the illustration. A beautifully imported Italian keyboard is part of each kit as well as a realistic looking soft (sustain) pedal (imported from England) is also supplied. All pre-cut woodwork is supplied.



GAD!
they've never
been
cheaper!
Jaycar
ELECTRONICS

ETI 342 CDI Type Electronic Ignition Ref: ETI Feb '85

This brand new design virtually eliminates the controversial problems of past CDI designs. Probably its biggest new feature is that it has all but eliminated the crossfire problem. Other features:

- High reliability factor.
- Runs from 2-25 volts supply.
- Doesn't create high coil current.
- Hall-effect trigger compatible.
- Will work on virtually any type of ignition motor. (i.e. Boats, planes etc).
- Diecast Box.

A real winner! Cat. KE4690

\$55



Jaycar ELECTRONICS

Incorporating ELECTRONIC AGENCIES
NUMBER 1 FOR KITS

N.S.W. SYDNEY: 117 York Street. Tel. (02) 267 1614
SHOWROOMS CARLINGFORD: Cnr. Carlingford & Pennant Hills Road. Tel. (02) 872 4444
CONCORD: 115/117 Parramatta Road. Tel. (02) 745 3077
QUEENSLAND HURSTVILLE: 121 Forest Road. Tel. (02) 570 7000
SHOWROOM BURANDA: 144 Logan Road. Tel. (07) 393 0777
Mon - Fri 9am - 5:30pm Saturday: 12pm
Thursday nights: 8:30pm

MAIL ORDERS: P.O. Box 480, AUBURN 2144. Tel. (02) 643 2000

HEAD OFFICE: 7/9 Rawson Street, AUBURN 2144.
Tel. (02) 643 2000 Telex. 72293

SHOP HOURS

Carlingford, Hurstville
Mon-Fri: 9am - 5:30pm, Thurs 8:30pm, Sat 12pm
Sydney
Mon-Fri: 8:30am - 5:30pm, Thurs 8:30pm, Sat 12pm
Concord
Mon-Fri: 9am - 5:30pm, Sat 12pm

POST & PACKING

\$5 - \$9.99 \$1.50
\$10 - \$24.99 \$3.20
\$25 - \$49.99 \$4.50
\$50 - \$99.99 \$6.50
\$100 - \$198 \$8.00
Over \$199 \$10.00

COMET ROAD FREIGHT ANYWHERE IN AUSTRALIA ONLY \$12

VISA

AMERICAN EXPRESS
Cards Welcome

MasterCard



MAIL ORDER VIA
YOUR PHONE

'Blue light' is brought to market

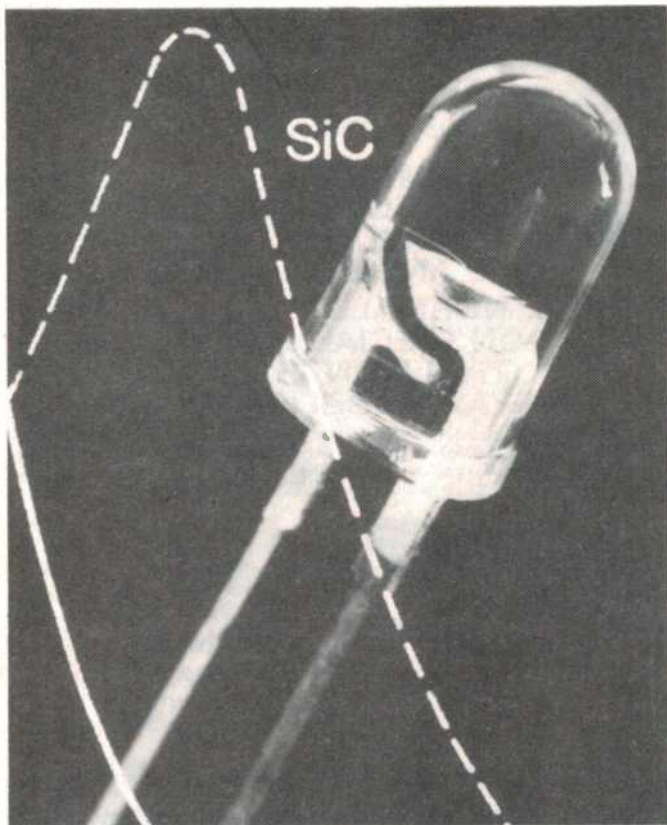

LEDs using crystalline semiconductors such as gallium, phosphorus and arsenic have provided red, yellow and green light for more than a decade now. LEDs that give off blue light, however, were still in the development stage.

Two years ago, Siemens devised a method of manufacturing 'blue light chips' at a considerably lower price, admittedly without matching the price level of LEDs in the other colours. Having sounded out the market, the company has now decided to include the fourth LED colour in its 1985 range — trial quantities can be indented from early 1985. The new blue LED (SLB 5410) operates at 480 nm and uses silicon carbide (SiC) as starting material.

SiC has emerged as the optimum semiconductor for blue light after years of research. Although it is labor and cost-intensive to produce, it has significant advantages over ZnSe or GaN: the SLB 5410 has a forward voltage of typically 4 V (20 mA), the corresponding figures being 10 V (20 mA) for ZnSe or GaN types.

The purity and reproducibility of the blue LED's 480 nm radiation are unequalled. Further

characteristics are a high impulse stability, a narrow spectral bandwidth and a very low aging rate. These features make the new LED suitable for use as a radiation source in spectroscopic, biophysical or medical applications, as a calibration source for TV camera and photographic equipment, and, later on, possibly even as a means for producing the blue luminous dots on flat colour screens.

The blue LED is less suitable for use as a mere on/off indicator than its red, yellow and green counterparts. Apart from higher costs, the angle of radiation and the intensity are lower than in conventional LEDs. Typical values are 4 mcd (20 mA) measured in the optical centre axis at a half-angle of eight degrees.

The SLB 5410 is mounted in a plastic package (5 mm); other packages are possible on request to Siemens Ltd, 544 Church St, Richmond Vic 3121. (03)429-7111.

Flash converters

Ampec electronics has announced the release of a range of CMOS flash converters.

These molybdenum gate converters provide high performance and powerful solutions for flash applications.

The 6-bit, MP7682 is a pin compatible, replacement for the RCA CA3300. It's faster (up to 30 MHz), more accurate (linearities to $\pm 1/4$ LSB), lower cost and less demanding on your signal conditioning (1 V reference). Two units in series provide 7-bit resolution, and two units in parallel double the through-put rate.

The 8-bit, MP7683 is a low

power (75 mW), two-step converter with a 10 MHz sampling rate. Its low cost makes it ideal for use in applications where price and power consumption are barriers.

The MP7684 is an 8-bit version. It has parallel architecture, a single 5 V supply, a 1 volt reference, and an overflow bit makes it one of the best available.

A 9-bit version will be available in 1985.

Samples, data sheets, applications boards and applications support are available. Please ring Ampec Electronics, PO Box 112, Fivedock NSW 2046. (02)712-2466.

IEC cord-type plug

IEC-type mains connectors are now fairly widely used on a variety of equipment. Usually a chassis-mounting plug is fitted to the equipment for power input, with a mating cord-type socket used on the end of the power cord. Both such fittings are now stocked by many dealers and retailers, along with complete cords.

However if you've been looking for a cord-type plug to attach to a different monitor than an

IBM, Geoff Wood has just obtained limited stocks of a high-quality imported plugs suitable for fitting to existing cords, and is offering them for \$2.95 each plus tax and postage if applicable.

Enquiries to Geoff Wood Electronics Pty Ltd, 656A Darling Street, Rozelle NSW 2039. (02)810-6845.

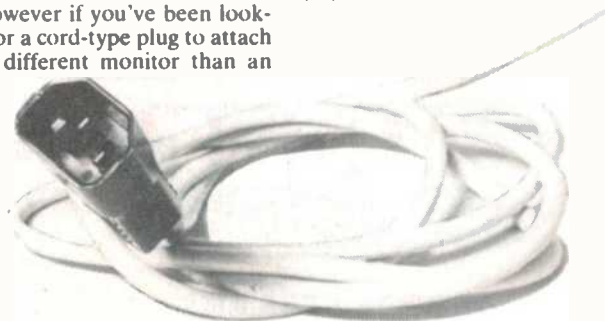

Connector catalogue

STC-Cannon Components has released the "MS standard Circular Connectors for Commercial, Military and Industrial Applications".

The 28 page catalogue details contact arrangements; alternative insert positions; solder/crimp contacts; high voltage cartridges; RFI shielding; mains power connectors and accessories.

Various shell styles, with complete technical details, are listed, i.e: wall mounting receptable, cable connecting plug, box mounting receptacle, straight plug and 90 degree angle plug. The MS Standard Circular Connectors Catalogue" is available on request to STC-Cannon Components, 248 Wickham Rd, Moorabbin, Vic 3189.

Wirewounds perform current sensing

Developed for four-terminal current sensing and printed circuit board mounting, the 4LPC series of wirewound fixed resistors from TRW offers resistance values of 0.01 to 1.0 ohm at 3 W, in tolerances from $\pm 5\%$ to $\pm 1\%$. The resistors are suitable for such applications as power supply regulation, motor controls, RF sampling, feedback control

loops, and overload sensors. Encased in a steatite ceramic case, the flameproof resistors offer a TCR of ± 40 ppm. Typical dimensions include a length of 0.925 inch, excluding terminals; a height of 0.413 inch, excluding leads; and a width of 0.354 inch.

For further information, contact Total Electronics, 9 Harker Street, Burwood Vic 3125. (03)288-4044.

Nectronics — new distributor

A new components distribution company has been formed by Irene Pellett who has had 20 years experience as a sales representative for firms supplying electronics components. She is joined by Lino Giambertone as sales consultant in the venture.

Nectronics Pty Ltd will act as sole agent for Euro Dip, marketing a range of machined IC sockets, as well as for American

Research and Engineering, makers of dip switches. Nectronics has also been appointed distributor for the Japanese company NEC. Other products Nectronics will carry include flat ribbon cable, connectors and sockets and other components from Japan, Europe and Hong Kong and Taiwan.

For further information contact Nectronics, 27 Lexton Rd, Box Hill, Vic 3128.

Manuals for semiconductors

Imark has again secured a limited quantity of data manuals with information on Japanese semiconductor devices. They include "The Transistor Manual", "The Transistor Substitution Manual", "The Diode Manual", "The FET Manual", "The Op-amp Manual" (Parts 1 and 2) as well as a series of IC manuals,

computer manuals and "The Power and Industrial Semiconductor Manual".

The manuals are priced at \$10.95 each plus \$4 p&p 1-13 manuals.

Further information is available from Imark Pty Ltd, 167 Roden St, West Melbourne, Vic 3003.

WITH
TANDON DRIVES YOUR COSTS
GO **LOW**

FLOPPIES WINCHESTER

- ★ Genuine world leading Tandon drives — not cheap copies
- ★ Fully warranted and serviced by sole Australian agents
- ★ Plug 'em in and run! Models to suit TRS-80, Apple II, IBM PC & XT, CAT, Challenger, & S100 systems. New models are being added regularly.

Floppies bare and encased — call for price
★ Winchester Systems to 30MB — low, low prices ★
IBM compatible hard disk systems to 30MB are 100 % compatible with the PC & XT
Apple compatible hard disk systems support DOS, CP/M and Pascal on one disk

B/CARD, VISA & AMEX WELCOME. ALL DRIVES SUPPLIED COMPLETE WITH CASE, CABLES & MANUALS SOFTWARE SUPPORTS POWER SUPPLY AS REQUIRED.

**CALL MICRO GENERAL (02) 398 8601
FOR THESE SPECIAL DEALS NOW!**

TELEX AA135042 "ATTN MICANGEN"
TRADE ENQUIRIES WELCOME

LAE POWER CONTROL

REMOTE CONTROL SYSTEM FOR LIGHTING AND APPLIANCES

LAE POWER-CONTROL SYSTEMS enables a wide range of micro-computers to control electrical devices by remote control. The system consists of an Interface-Transmitter, up to 30 low cost Receivers, and a comprehensive application software for popular micro-computers.

There is no need for additional wiring of any kind, because the system communicates over existing 240V A.C. wiring. Selected devices simply plug into the portable Appliance receivers, and the receivers are plugged into any 240V A.C. power point in the building. Light receivers have a dimming capability, and they are available in "plug-in" and "wire-in" versions. You can start with a system for less than \$230.00 that will provide energy saving, security and convenience.

LAE POWER-CONTROL SYSTEM is totally designed and manufactured in Australia for Australian conditions. Portable receivers are fully approved by the Australian Energy Authority. For more information contact
LEMIC ADVANCED ELECTRONICS PTY. LTD.
DEALER ENQUIRIES WELCOME.

LAE LEMIC ADVANCED ELECTRONICS PTY. LTD.
(INCORPORATED IN VICTORIA)

135 Roseneath Street, North Geelong
P.O. Box 187, Corio, Vic. 3214, Australia Phone: (052) 78 4254

AT LAST!

A LOW COST, RELIABLE BREATH ALCOHOL TESTER

Are you prepared to take a chance with booze buses? Just think: with one of these in the glovebox you can drive easy! Accurately calibrated for 0.05% - and small enough to take along to the party or pub.

Note: not a legal check. No liability assumed. Cat Y-4000



ONLY
\$79⁹⁵



SAVE ON 'PHONES

Here's value: a set of top quality Mylar 'phones reduced even more than our normal bargain price! When you want the best quality sound... this is it! Cat C-4124



\$34.95
NORMALLY
NOW ONLY

\$29⁹⁵

NEW!

IN-EAR 'PHONES

You'll be amazed at the sound quality from these beauties! Fit inside your ear - lightweight comfy and sound like a million dollars! Cat C-4095



ONLY **\$9⁹⁵**

GOING FAST...

Want a new turntable? This deluxe belt drive model comes with high quality ADC mag cartridge - and look, at the price. Cat A-3010

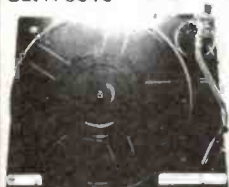

ONLY
\$59⁰⁰

OR A CHEAPIE?

Ideal for the kids! let them play with this one and keep the good one for your records. Cat A-3015



\$27⁵⁰

THE DICK SMITH SOLDERING STATION -



Features fully variable temperature control (from around 200 degrees to over 500 degrees Celsius) with a temperature meter to show you what's happening. And it's fully approved by the Energy Authority. The station comes complete with lightweight iron, iron holder and cleaning sponge, with a comprehensive instruction manual with full servicing information included. Cat T-2000

JUST **\$69⁰⁰**

MORE FANTASTIC SEMICONDUCTOR SPECIALS!

Type	Cat	Was	Now
3mm green LEDs (premium qual)	Z-4079	.35	.30
5mm green LEDs (prem qual)	Z-4087	.35	.30
3mm orange LEDs (prem qual)	Z-4083	.50	.40
5mm orange LEDs (prem qual)	Z-4091	.40	.35
5mm yellow LEDs (prem qual)	Z-4089	.40	.35
5x2mm red LEDs (prem qual)	Z-4093	.35	.30
0.3in 7 seg disp (comm cath)	Z-4103	\$ 1.95	\$ 1.45
9 digit LED display	Z-4155	\$ 1.50	.95
2513 Character Generator	Z-9206	\$22.50	\$17.50
MM5865N Timer IC	Z-6816	\$ 7.50	\$ 5.50
2N3053 Transistor	Z-2130	\$ 1.00	.75
MPF31 FET	Z-1848	\$ 1.65	\$ 1.25
81LS95 Tri state Octal Driver	Z-5300	\$ 2.95	\$ 2.45
LM301 Op Amp	Z-6040	\$ 1.00	.75
LM3909 Oscillator	Z-6109	\$ 1.95	\$ 1.45
LM3914 10 LED driver	Z-6295	\$ 4.95	\$ 4.49
LM394C Super Matched Preamp	Z-6083	\$ 6.50	\$ 6.00
CA3080 Transconduct Op Amp	Z-6024	\$ 2.45	\$ 1.95
4013 Dual D Flip Flop	Z-5613	\$ 1.00	.75
4015 Dual 4 bit shift reg	Z-5615	\$ 1.25	\$ 1.15
4017 Decade Counter/divider	Z-5617	\$ 1.30	\$ 1.20
4019 Quad and/or/select	Z-5619	\$ 1.10	.90
4020 14 bit counter	Z-5620	\$ 1.50	\$ 1.35
4025 Triple 3 input NOR	Z-5625	.60	.50
4027 Dual JK flip flop	Z-5624	\$ 1.20	.95
4071 Quad 2 input OR	Z-5671	.60	.50
4082 Dual 4 input AND	Z-5682	.60	.50
40303 Quad Exclusive OR	Z-5630	\$ 1.20	.95
4116 250nS dynamic RAM	Z-9310	\$ 2.95	\$ 1.95
4511 BCD/7 seg decoder	Z-5730	\$ 1.95	\$ 1.75
4518 Dual BCD up counter	Z-5740	\$ 1.95	\$ 1.65
2732 Intel EPROM	Z-9209	\$14.95	\$ 9.95
DS1488 Quad Line driver	Z-5370	\$ 1.95	\$ 1.75
TL071 (LF351N) JFET op amp	Z-6030	\$ 1.20	\$ 1.00
7401 Quad 2 input NAND	Z-5011	.80	.70
7473 Dual JK flip flop	Z-5073	.85	.75
7474 Dual D Flip Flop	Z-5074	.85	.75
790 Decade Counter	Z-5090	.90	.80
74LS86 Quad 2 input OR	Z-4986	\$ 1.00	.75
74LS95 4 bit L-R shift reg	Z-4995	\$ 1.50	\$ 1.25
74C946 4.5 digit LCD driver	Z-6301	\$19.95	\$17.95
Audio Modulator	K-6042	\$ 2.25	\$ 1.95
5-70pF Trimmer	R-2915	.95	.65
10-100pF Trimmer	R-2917	.95	.65
40 pin IC socket	P-4250	.75	.50
18 pin IC socket	P-4180	.40	.30
C size Nicad	S-3305	\$ 3.95	\$ 2.95
Grommet Pack	H-1716	.90	.70
Plastic project case	H-2520	\$12.50	\$ 9.50

LAST CHANCE...

TO WIN A UHF REPEATER FOR YOUR CLUB AND AN HF or V/UHF STATION FOR YOURSELF!

Our fantastic 'Win a Yaesu Repeater' contest definitely finishes this month. Don't miss your chance to win a UHF repeater for your club AND a complete amateur station for yourself! All you have to do is buy any item of Yaesu Amateur Radio

Equipment from your nearest Dick Smith Electronics store or DSXpress. Fill in the entry form provided - tell us why your club should win the repeater - and you could be a winner with Yaesu and Dick Smith Electronics.



CONTEST CLOSSES FEB 28th HURRY!

NEW!

DUAL TEMP SOLDERING IRON



Convenient! Standard 30 watt iron for all those normal jobs, but press the button and you have double power for instant heat or for heavy duty stuff 240V element...what a beauty!!!
Cat T-1830

ONLY **\$32⁵⁰**

ANOTHER NEW STORE

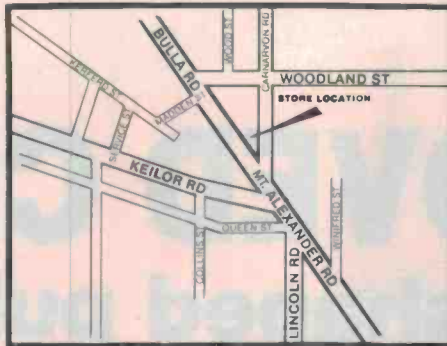

**1148 MT ALEXANDER RD
ESSENDON VIC** Ph 379 7444
STORE DUE TO OPEN SOON IN
SHOP 205 INDOOROPILLY
SHOPPING TOWN,
INDOOROPILLY, 4068

SPECIAL OFFER THROUGH

DSX^{PRESS}
DICK SMITH ELECTRONICS EXPRESS ORDER SERVICE

FREE AIR FREIGHT ANYWHERE IN AUSTRALIA

THIS MONTH ONLY

Yes! Order through DSXpress - and we'll air freight your order anywhere in Australia absolutely FREE this month! See our mail order page elsewhere in this magazine.

STORE LOCATIONS

NSW		VIC		QLD		WA		SA		NT	
Cnr. Swift & Young Sts.	Albury 21 8399	6 Bridge St	Sydney 27 5051	Gympie & Hamilton Rds	Chermside 359 6255						
Paramatta Rd & Melton St	Auburn 648 0558	125 York St	Sydney 267 9111	Cnr Queen Elizabeth Dr & Bernard St	Rockhampton 27 9644						
T55 Terrace Level	Bankstown Sq. 707 4888	Tamworth Acde & Kable Ave	Tamworth 66 1961	Cnr Gold Coast Hwy & Welch St	Southport 32 9863						
Shop 1, 85-75 Main St	Blacktown 671 7722	263 Keira St	Wollongong 28 3800	Bowen & Ruthven Sts	Toowoomba 38 4300						
613 Princess Hwy	Blakehurst 546 7744	ACT	Fyshwick 80 4944	Ingham Rd & Cowley St. West End	Townsville 72 5722						
Oxford & Adelaide Sts	Bondi Junction 387 1444	96 Gladstone St		SA							
531 Pittwater Rd	Brookvale 93 0441	VIC		Wright & Market Sts	Adelaide 212 1962						
Campbelltown Mall, Queen St	Campbelltown 27 2199	Creswick Rd & Webster St	Ballarat 31 5433	Main South & Flagstaff Rds	Darlington 298 8977						
Shop 3, 235 Archer St Entrance	Chatswood Chase 411 1955	145 McCrae St	Bendigo 43 0388	Main North Rd & Darlington St	Enfield 260 6088						
147 Hume Hwy	Chullora 642 8922	Shop 46, Box Hill Central, Main St	Box Hill 890 0690	24 Park Terrace	Salisbury 281 1593						
162 Pacific Hwy	Cnr Hawthorn Rd & Nepean Hwy	260 Sydney Rd	East Brighton 592 2366	WA							
315 Mann St	Gosford 25 0235	Nepean Hwy & Ross Smith Ave	Coburg 383 4455	Wharf St & Albany Hwy	Cannington 451 8666						
4 Florence St	Hornsby 477 6633	205 Melbourne Rd	Frankston 783 9144	66 Adelaide St	Fremantle 335 9733						
Elizabeth Dr & Bathurst St	Liverpool 600 9888	291-293 Elizabeth St	Geelong 78 6766	William St & Robinson Ave	North Perth 328 6944						
450 High St	Maitland 33 7866	Bridge Rd & The Boulevarde	Melbourne 67 9834	Centreway Acde, Hay St	Perth City 321 4357						
173 Maitland Rd, Tighes Hill	Newcastle 61 1896	Springvale & Dandenong Rds	Richmond 428 1614	TAS							
Lane Cove & Waterloo Rds	North Ryde 88 3855	QLD	Springvale 547 0522	25 Barrack St	Hobart 31 0800						
George & Smith Sts	Parramatta 689 2188	293 Adelaide St	Brisbane 229 9377	NT							
The Gateway, High & Henry Sts	Penrith 32 3400	166 Logan Rll	Buranda 391 6233	17 Stuart Hwy	Stuart Park 81 1977						
818 George St	Railway Sq 211 3777										

Dear Customers,

Quite often, the products we advertise are so popular they run out within a few days, or unforeseen circumstances might hold up shipments so that advertised lines are not in the stores by the time the advert appears. And very occasionally, an error might slip through our checks and appear in the advert (after all, we're human too!). Please don't blame the store manager or staff; they cannot solve a dock strike on the other side of the world, nor fix an error that's appeared in print. If you're about to drive across town to pick up an advertised line, why not play it safe and give them a call first... just in case! Thanks. Dick Smith Electronics

MAJOR RESELLERS

These are independent businesses which stock a large range of Dick Smith Electronics products. However we cannot guarantee they will have these items or at the price advertised.

NSW — Ballina: A. Cummings & Co. 91-93 River St 86 2284 ● Bowral: Barry Gash Electronics, 370 Bong Bong St 61 2577 ● Broken Hill: Hobbies & Electronics, 37 Oxide St 88 4098 ● Charlestown: Newtronics, 131 Pacific Hwy 43 9600 ● Coffs Harbour: Coffs Harbour Electronics, 3 Coffs Plaza, Park Ave 52 5684 ● Deniliquin: Deni Electronics, 220 Cressy St 81 3872 ● East Maitland: East Maitland Electronics, 99 High St 33 7327 ● Gosford: Tomorrows Electronics & HiFi, 68 William St 24 7246 ● Inverell: Lyn Willing TV, 22A Evans St 22 1821 ● Lismore: Decro Electronics, 3A/B-18 Carrington St 21 4137 ● Port Macquarie: Hall of Electronics, Horton Centre, Horton St 83 7440 ● Orange: M & W Electronics, 173 Summer St 62 6491 ● South Tweed Heads: Shop 1, Inessa Court, Blundell Boulevard 36 1077 ● Swansea: Swansea Electronics, 184 High St 71 1674 ● Wagga: Wagga Wholesale Electronics, 89 Forsyth St ● VIC — Hamilton: John Thompson & Co, 138-148 Gray St 72 2000 ● Echuca: Webster Electronics, 220 Packerham St 82 2956 ● Mildura: McWilliams Electronics, 110A Langtree Ave 23 6410 ● Morwell: Morwell Electronics, 95 George St 34 6133 ● Shepparton: G.V. Electronics Centre, 100 High St 21 8866 ● QLD — Atherton: Maarten's Music Centre, 55 Main St 91 1208 ● Bundaberg: P.M. Electronics, Takalvan St 72 8272 ● Cairns: Electronic World Shop, 27 K-Mart, Westcourt Plaza, Mulgrave Rd 51 8555 ● Gladstone: Purely Electronics Shop, 2 Cnr Herbert & Auckland Sts 72 4321 ● Mackay: Stevens Electronics, 42 Victoria St 51 1723 ● Maryborough: Keller Electronics, 218 Adelaide St 21 4559 ● Rockhampton: Purely Electronics, 15 East St 21 058 ● SA — Mt Gambier: Hutchesson's Comm. 5 Elizabeth St 25 6404 ● Whyalla: Eyre Electronics, Shop 2 Forsythe St 45 4764 ● WA — Albany: Micro Electronics, 133 Lockyer Ave 41 3432 ● TAS — Launceston: Advanced Electronics, 5A The Quadrant 34 1399 ● NT — Darwin: Ventronics, 24-26 Cavanagh St 81 3491

HEAD OFFICE & **DSX^{PRESS}** ORDER SERVICE

P.O. Box 321, North Ryde, N.S.W. 2113. Tel: 888 3200 Telex AA20036

SPEEDY PHONE/BANKCARD ORDER SERVICE

Just phone your order and Bankcard — it's so simple! (02) 888 2105 orders only on this number. Enquiries: (02) 888 3200

POST & PACKING CHARGES

Order Value	Charge	Order Value	Charge
\$ 5.00-\$ 9.99	\$2.00	\$50.00-\$99.99	\$6.00
\$10.00-\$24.99	\$3.50	\$100 or more	\$8.00
\$25.00-\$49.99	\$4.50		

Terms available to approved personal applicants



(SA Credit facilities available through Custom Credit Corp. 422 King William St. Adelaide)



PTY LTD

IMPROVED CDI

— using shaped pulses

Part 1

by Ian Thomas

Capacitor discharge ignition systems are much more efficient than conventional or transistor assisted systems, and they're also much better at getting maximum performance from today's engines. Unfortunately early CDI systems were also unreliable and plagued by problems such as engine cross-firing. Here's a new design which gets around all of the problems, but still gives you all of the benefits.



THERE HAS BEEN a lot of criticism of capacitor discharge ignition systems in the technical magazines recently. Some of it was well founded and some was merely relevant to particular designs. From what I've read the principle has often been blamed for problems in certain circuit realizations and so, after some discussion with our beloved editor, I decided to set the record straight.

Desirabilities

The first thing to get clear is exactly what is desirable in an electronic car ignition system. The basic requirement is to generate a spark to set fire to the air fuel mixture in the engine cylinders at exactly the right time. As most cars today have to meet emission control requirements, this means that the air fuel mixture is leaner than optimum and so the spark should last for as long as possible. The next requirement is that the voltage pulse applied to the spark plugs rises rapidly so that, if the plugs are fouled comparatively little energy is lost in the fouling and most of the energy actually goes into the spark. CDI systems are exceptionally good at this, in fact, they're too good. This means that the pulse applied to one plug will capacitively couple to other plug leads

and possibly fire the fuel in other cylinders at terribly wrong times. This creates two mutually opposed requirements for the ignition system; the firing pulse leading edge

should be fast but not too fast. Clearly if we are to design an ideal system the output voltage pulse rising edge should be a controlled parameter.

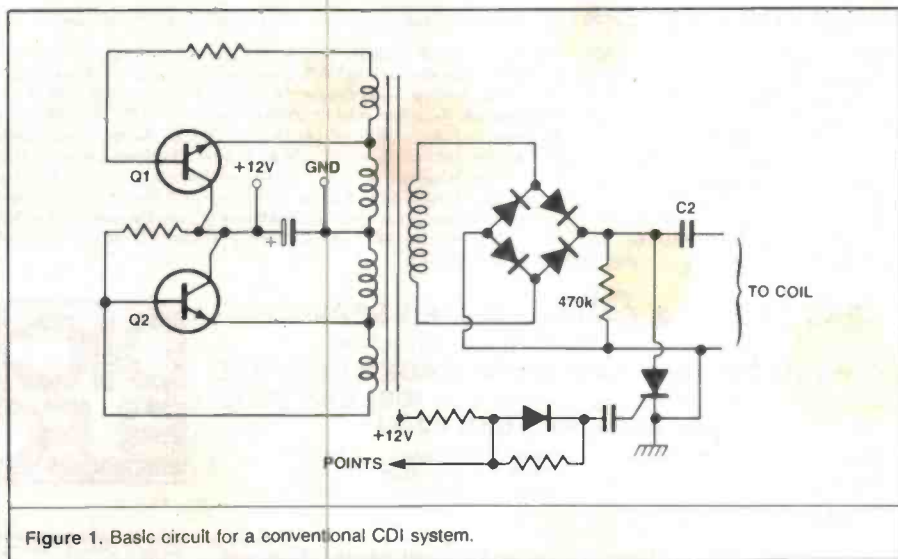

Figure 1. Basic circuit for a conventional CDI system.

The third and, in my opinion, the most important requirement is that the system *must be reliable*. The most incredible whizz-bang, mind blowing device ever contrived could be built, but if it only works 90 per cent of the time it's not worth a damn and shouldn't be let anywhere near a vehicle. In the good old days when CDIs first made their appearance it simply wasn't appreciated just how hostile the environment under the bonnet of a car is for electronics. I'm sure that if the Marquis de Sade was alive today and thought about what electronics is subjected to near a running petrol engine he'd get that kinky warm feeling all over. It's stinking hot. There are fierce voltage transients everywhere. The power supply is subject to violent excursions. There are corrosive fluids around. All in all it's a good place not to put sensitive semiconductors. Nonetheless we went blithely ahead and attached our crude systems right next to the coil and cursed everything in sight when they fell over even though we'd used only the cheapest commercial components available.

In these more enlightened times all devices used for automotive operation are usually specified for the full military temperature range of -55°C to $+125^{\circ}\text{C}$. In Australia the -55° may not be necessary but the $+125^{\circ}$ is.

Finally, our ideal system should allow for the output pulse to be increased during starting and also it should be controllable so a car burglar alarm can shut it off. It should be triggerable from a Hall effect sensor or existing points. It goes without saying that it should not be possible to damage the device from any terminal by wrong connection or inadvertent shorts.

In the "wouldn't it be nice if..." category I thought an ideal system would not be effected by supply variations and would give the same output pulse no matter what the supply voltage.

As a matter of technical nicety it would also be good if the device was as efficient as possible so things didn't get too hot (see above about reliability). As a general rule the reliability of any electronic component halves for every 11°C temperature rise. That is, if a device (say a transistor) is expected to fail once in 10 000 hours at an operating temperature of 55°C then at 66°C it

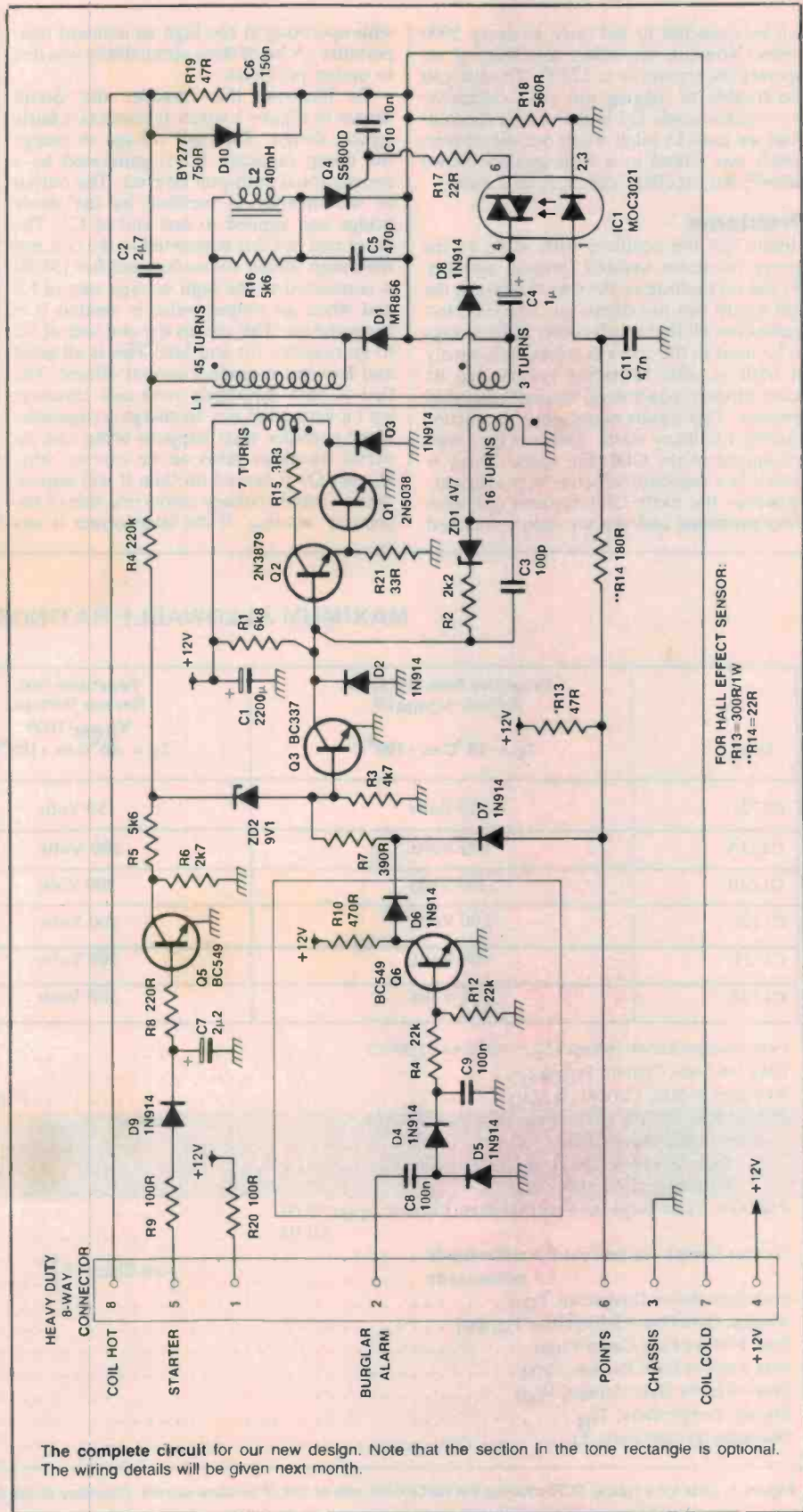
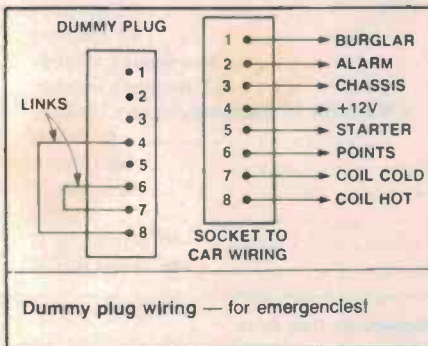

The complete circuit for our new design. Note that the section in the tone rectangle is optional. The wiring details will be given next month.

can be expected to fail once in every 5000 hours. You can see where this leads if we operate the transistor at 125°C. To save you the trouble of digging out your calculator it's a failure each 121 hours to be expected! And we used to bitch when our electronics which was baked to a light golden brown failed!! An excellent rule is *cold is good*.

Problems

Herein lies the problem with some of the newer transistor assisted ignition systems. By the very nature of the way they work the coil has to run too damn hot and the electronics not all that much cooler. The energy to be used in the spark is stored inductively in both ye olde Kettering system and its more modern equivalent transistor assisted ignition. This means many amps and hence entirely too many watts. This was the original appeal of the CDI; the spark energy is stored in a capacitor which is very efficient. However the early CDI systems did have their problems and not all were associated

with operating at too high an ambient temperature. A lot of their unreliability was due to design problems.

To illustrate this consider the circuit shown in Figure 1 which represents a fairly typical design. The high voltage to charge the dump capacitor C2 is generated by a conventional push-pull inverter. The output of the inverter is rectified by the diode bridge and applied to one end of C2. The other end of C2 is connected to the coil and the dump silicon controlled rectifier (SCR) is connected to the high voltage side of C2 and when an output pulse is wanted it is triggered on. This causes the coil side of C2 to go negative far and fast! This is all good and fine but it ignores several effects. The first is that saturating push-pull inverters isn't a very good way to charge a capacitor. If we consider what happens when one inverter transistor turns on we can see why. If, say, Q1 is turned on then it will impose the full supply voltage across one side of the primary winding. If the transformer is any

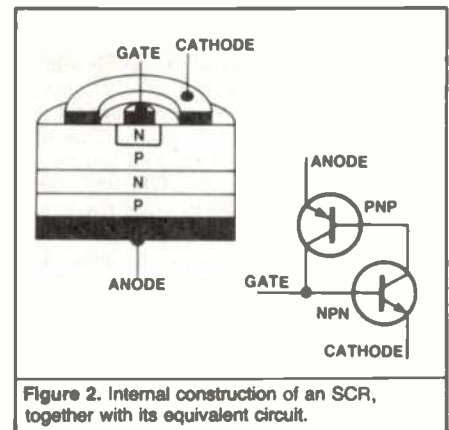

Figure 2. Internal construction of an SCR, together with its equivalent circuit.

good then the voltage across the output winding is exactly the primary to secondary turns ratio times the supply voltage. If the capacitor is just beginning to charge then a conflict occurs and the voltage across the secondary must be taken up by other com-

MAXIMUM ALLOWABLE RATINGS

Type	Repetitive Peak Off-State Voltage, $V_{DRM(3)}$ $T_C = -40^\circ\text{C to } +100^\circ\text{C}$	Repetitive Peak Reverse Voltage, $V_{RRM(1)(3)}$ $T_C = -40^\circ\text{C to } +100^\circ\text{C}$	Non-Repetitive Peak Reverse Voltage, $V_{RSM(1)(2)}$ $T_C = -40^\circ\text{C to } +100^\circ\text{C}$
C122F	50 Volts	50 Volts	75 Volts
C122A	100 Volts	100 Volts	200 Volts
C122B	200 Volts	200 Volts	300 Volts
C122C	300 Volts	300 Volts	400 Volts
C122D	400 Volts	400 Volts	500 Volts
C122E	500 Volts	500 Volts	600 Volts

Peak positive anode voltage ($T_C = -40^\circ\text{C to } +100^\circ\text{C}$)	560 Volts
RMS On-State Current, $I_{T(RMS)}$	8 Amperes (all conduction angles)
Average On-State Current, $I_{T(AV)}$	Depends on conduction angle (See Charts 3 and 4)
Critical Rate-Of-Rise of On-State Current, di/dt : (4)	
Gate triggered operation	(see Chart 10)
Switching from 200 volts	100 Amperes per microsecond
Switching from 500 volts	50 Amperes per microsecond
Peak One Cycle Surge (non-rep) On-State Current, I_{TSM} 50 Hz	82 Amperes
60 Hz	90 Amperes
I^2t (for fusing), for times at 8.3 milliseconds	} see Chart 12 {
1.5 milliseconds	
Peak Gate Power Dissipation, P_{GM}	5 Watts for 10 microseconds (see Chart 6)
Average Gate Power Dissipation, $P_{G(AV)}$	0.5 Watts
Peak Positive Gate Current I_{GM}	see Chart 6
Peak Positive Gate Voltage, V_{GM}	see Chart 6
Peak Negative Gate Voltage, V_{GM}	5 Volts
Storage Temperature, T_{stg}	$-40^\circ\text{C to } +125^\circ\text{C}$
Operating Temperature, T_J	$-40^\circ\text{C to } +100^\circ\text{C}$

Figure 3. Data for a typical SCR showing the limit for the rate of rise of on-state current. (Courtesy of GE Semiconductor Data Book.)

ponents. Normally this voltage appears across the ignition coil and for the inverter to work correctly the coil must be entirely inductive. If there are large stray parasitic capacitances in the ignition coil primary then the load they present to the inverter may stall it or at best hold the main inverter transistors out of saturation until they're charged. This process is inefficient and makes for a hot inverter. Certainly the push-pull inverter will not tolerate a highly capacitive load.

The next and far more serious effect occurs when the dump SCR is triggered on. The actual works of an SCR consist of a piece of silicon, shown in cross section in Figure 2, along with an equivalent two transistor circuit. Physically the gate lead is connected to a point in the centre of the silicon die. When the SCR is triggered on a positive pulse is applied to the gate in the centre to momentarily turn on the NPN transistor in the equivalent circuit. This in turn turns on the PNP transistor and the very high positive feedback of the two transistors causes the SCR to go to a highly conductive state where it will remain until the current is removed.

However when the trigger pulse is first applied *only the region near the gate terminal is turned on*. It takes a microsecond or so for the on state to spread across the whole SCR. If the current is allowed to rise through the SCR faster than the on state spreads then the small part of the SCR that has latched on will be overloaded *and the SCR will be destroyed!* The region of the SCR will have far too high a current density flowing through it and will be burnt out. Figure 3 shows part of the data sheet of an SCR and is the absolute maximum ratings for the device. The line in colour relates to this problem. It shows that the on state current must not be allowed to rise faster than 100 A/ μ s. If such a circuit is to operate reliably then the current through the SCR *must* be controlled. This is normally done by inserting an inductor in series with the SCR and will ensure the SCR will survive most forms of abuse but if it's left out the CDI will have almost no resistance to a shorted coil or a highly capacitive coil primary. It doesn't matter how big the SCR is; it's easy to destroy it during the first instants of turn on.

The choice of capacitor for the dump capacitor is very important too. During the dump cycle the capacitor is discharged in about 50 microseconds (give or take) and this means torrents of amps. The old standby is Philips 'liquorice allsort' capacitors aren't good enough; devices rated for high current must be selected. If the capacitor is rated for 240 Vac operation then it's a good bet it'll be OK for CDI usage too.

Another mistake made in a lot of the earlier designs was to overdo things. Just because it was easy to do, people used to use outrageous voltages on the dump capacitors which in turn generated ridiculous ignition voltages. In my earlier days I was guilty of

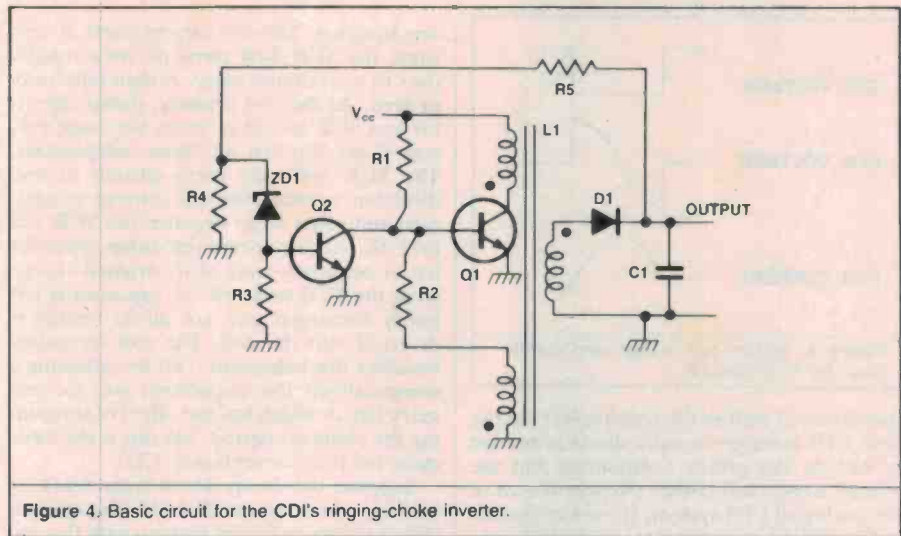

Figure 4. Basic circuit for the CDI's ringing-choke inverter.

this sin also. I recall looking in awe under the bonnet of my car in the dark when the engine was running. The whole ignition harness was outlined in blue corona discharge. Gadzooks but it was spectacular!! Not a whole lot of use though.

What should be done

This more or less outlines the things to avoid doing, but what should be done? Since CDI was to be used the first decision was the choice of an inverter configuration. One of the most flexible inverter circuits available is the so-called flyback, single ended or ringing choke inverter. The basic circuit is shown in Figure 4 and works as follows. When power is first applied Q1 is biased on through R1 and current flows through the primary winding of L1. Because this imposes the full supply across the primary, the base drive winding generates a voltage equal to the primary-to-base winding turns ratio times V_{cc} . The base winding is connected with the polarity such that R2 also turns on Q1. As the voltage across L1 is constant (ignoring the saturation voltage of the transistor) the current through it will rise linearly with time and the current is described by:

$$I_{\text{peak}} = \frac{V_{cc}t}{L}$$

After a certain time R1 and R2 will not be able to provide enough base current to hold Q1 in saturation and its collector voltage will start to rise. This reduces the base drive voltage for R2 and further pulls the transistor out of saturation. The whole process runs away and results in Q1 being turned hard off. Before Q1 is turned off the current flowing through L1 represents energy stored in the inductor and this energy must go somewhere. Thus when Q1 turns off its collector voltage rises very rapidly and, as the output winding is also on the same core its voltage also rises until diode D1 is turned on. The energy stored in the inductor is

dumped out through D1 into the output filter capacitor C1. As soon as all the energy is removed from L1 the voltages across all the windings go to zero (ignoring stray ringing effects) and the whole cycle can be repeated. Thus C1 is 'pumped up' until its voltage is sufficient to turn on the zener diode ZD1 and hence Q2. When this happens Q2 steals all the base drive from Q1 and stops the oscillation. In fact if Q2 is removed or fails then the output voltage will rise until something breaks!

This circuit configuration has many advantages. The first is that when the current is being run up on the inductor the output diode is off and vice versa. This results in the output circuit being completely isolated from the input which means that doing bad things to the load doesn't bother the inverter at all. Even shorting out C1 completely doesn't damage anything. All that happens is that the current in L1 runs down to zero very slowly and the whole inverter acts as a constant current generator into the short. As soon as the short is removed the output voltage will rise to its regulated value again.

The second advantage is that the output voltage is determined by R4, R5 and ZD1 *only*. There is no relationship between the primary supply voltage and output at all. This enables the inverter to generate the same output voltage for a very wide range of input voltages always with (more or less) the same high efficiency. As an example the final inverter used in the ignition system will run off 2 volts to 25 volts in and the final voltage on the dump capacitor is 300 volts *over the entire input range*. The only thing that varies is the time taken to charge the capacitor.

The third advantage is that the circuit contains very few components and therefore should be very reliable. The only components that have to handle the full output power are Q1, L1 and D1. This compares *most favourably* with the more conventional circuit where there are four diodes and two

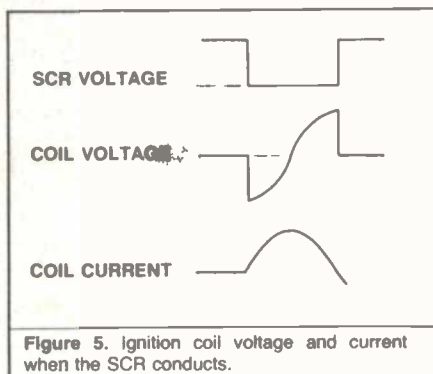

Figure 5. Ignition coil voltage and current when the SCR conducts.

transistors as well as the transformer. In the final CDI inverter an extra diode is needed as well as low power components but the overall design still comes out way ahead of the push-pull CDI system. It even compares well with the components needed for the transistor assisted ignition.

If this type of inverter has all these advantages then why hasn't it been used before? To be quite honest I have to admit I don't know. The only real drawback is that the inverter inductor has to store all the energy being transferred. This makes the inductor somewhat larger than the transformer in a push-pull inverter. Another disadvantage is that the peak current in the inductor is large (in the final design it's about 18 to 20 amps) so the power drawn from the supply is 'lumpy'. This makes supply bypassing more important and a good quality bypass capacitor must be used (but more about this later). The recent upsurge in switchmode power supplies has made both of these problems very easily solved as ferrite cores are easily available to make a suitable inductor and good electrolytic capacitors are also now common.

Since the flyback inverter will do all we want it's a cert for the final design. The next problem to be addressed is that of short spark duration with a CDI system. Referring back to the circuit diagram of a 'conventional' CDI it is instructive to consider what happens during the entire dump cycle. The first thing to happen is that the SCR is triggered on and the voltage across it collapses to zero from the original 300 to 400 volts. As the voltage across a capacitor cannot change instantly the other side of the dump capacitor which is connected to the coil immediately goes to -300 to -400 volts. The voltage rise across the coil is usually of the order of a microsecond or so. The SCR remains on and clamps the inverter end of the dump capacitor so the coil end of the capacitor resonates with the ignition coil primary inductance. Typically the coil inductance is of the order of 10 millihenries and the usual value of dump capacitor is 1µF so the combination resonates at about 1.6 kHz. The waveforms appearing on the coil primary and the coil primary current are both shown in Figure 5. The coil primary voltage is described by a -cos function and the coil current is described by a

sine function. The coil current starts at zero when the SCR first turns on then rapidly rises to a maximum value. It then falls away to zero. As the coil primary, dump capacitor and SCR are all in series the same current flows through all three components. The SCR will only carry current in one direction so when the coil current reaches zero and starts to go negative the SCR will turn off. At this instant the dump capacitor has re-acquired some of its original charge so as the SCR turns off the capacitor is left partly recharged and not all its energy is diverted into the coil. The coil secondary modifies this behaviour a bit by reflecting a comparatively low impedance into the primary circuit which has the effect of shortening the resonant period; but this is the basic cycle for the 'conventional' CDI.

Suppose the dump circuit is modified by adding a diode in parallel with the ignition coil as shown in Figure 6 along with the coil primary voltage and current. The first part of the dump cycle is exactly as for the earlier circuit. The SCR turns on and forces the coil-capacitor node negative. This reverse biases the diode which has no effect on the first quarter cycle of the dump. The coil primary current rises following a sine curve and peaks when the coil voltage passes through zero. The coil secondary voltage rises very (very!) rapidly following the primary voltage until the spark gap breaks down, then collapses to a comparatively low value (only 1000 volts or so). The coil secondary current then rises following a sine curve similar to the primary except at a lower level.

However when the primary voltage attempts to change sign due to resonance with the dump capacitor the clamp diode turns on and shorts out the coil primary. This forces the currents in both the coil primary-clamp diode circuit and secondary-spark gap circuit to decay away due to losses in the two circuits and the dominant loss is the spark gap. Thus all the energy in the dump capacitor is transferred to the coil and thence to the spark gap. This has the effect of lengthening the spark duration exactly as is wanted! Even if the turbulence in the combustion chamber momentarily blows out the arc it is open circuiting an inductor carrying high current so the gap voltage immediately rises to (very) high levels again and restrikes the arc. This would seem to be a pretty good way to have things as in the final design the arc duration is usually about 0.6 to 0.8 milliseconds — about the same as in the newer transistor assisted ignition systems. The only drawback with inserting a clamp diode in a 'conventional' push-pull inverter system is that during the capacitor recharging cycle the inverter must drive into an almost purely capacitive load, as during charging the clamp diode is forward biased and shorts out the coil for the inverter. For reasons already discussed push-pull inverters just won't work into this sort of load. As luck would have it the flyback inverter is perfectly happy working into these condi-

tions (not entirely coincidentally). There is also the further slight advantage that when the inverter is recharging the dump capacitor, the coil is inherently shorted out by the clamp diode and absolutely no charge voltages appear at the coil output. It also means that after the first quarter cycle of the dump the diode is turned on and, if necessary (if you're really in a hurry) capacitor recharging can be allowed to commence, but more of this later.

Rise time & pulses

This seems to solve all the so-called problems associated with CDI except that of too fast a rise time on the output voltage. To be honest this one had me worried for a while and the CDI which I used with great success for many years had the so called cross firing problem (but never gave a sign of it). The car I had then was a Mazda R100 and in fact there were two CDIs in it as the car had dual ignition. The rotors were fired alternately and it would seem an ideal arrangement for cross firing but then the leads were spaced well apart. All in all I have very fond memories of that car — apart from the fact that engines had to be regarded as consumables but no matter. My current iron steed is a 4.2 litre V8 Torana so cross firing had to be dealt with.

To understand the way the coil primary voltage rise time is controlled it's necessary to look into the design of the flyback inverter in some detail. A decision that was made very early on in the design was that the inverter transistor on time was to be about 20 microseconds. This is about as fast as the inverter can be run before transistor switching losses become a nuisance. For the dump capacitor to be recharged in 2 milliseconds or so the peak inverter current has to be allowed to run up to 15 to 20 amps before turn off. At first this may seem a bit fierce but there's no trouble finding suitable transistors and the main inverter transistor has a much easier life than the one used in a transistor assisted ignition! The high currents make it a good idea to run the inverter at as high a frequency as possible to make bypassing manageable. Given the inverter peak current and runup time the value of inverter primary inductance can be calculated from:

$$L_p = \frac{V_t}{I_{pk}} = \frac{13.6 \times 20 \times 10^{-6}}{20} = 13.6 \text{ microhenries}$$

For many and varied reasons the inverter primary to secondary turns ratio needs to be 6 or 7 to 1. This from simple arithmetic means that the inductance seen looking into the inverter transformer secondary will be 36 or 49 times the primary inductance. In the final inverter the turns ratio is 6.4 to 1 so the inverter secondary inductance is about 550 microhenries. So what did I hear you say? Tut! have patience!

It isn't written in words of fire that the in-

PROFESSIONAL QUALITY ELECTRONIC COMPONENTS



CT-6/9/20 series range of sealed cermet trimmers — single and multturn. 10% tol. 0.5W 1% C.R.V.

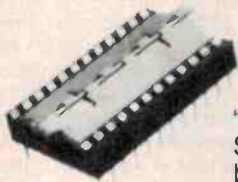

"NIF" No Insertion Force IC Socket: Low profile, small body size. Available in 24, 28, 40 and 48 pin.



High reliability computer grade electrolytic capacitors high capacitive



Machine Pin 4 Leaf Gold Contact low profile IC Sockets. Available with solder pin or 3 wire wrap 6-40 pin.



Uni-mess Box
Hand held enclosure with battery compartment and digital or analog readout panel



MAYER KRIEG & CO.

248 ANGAS ST., ADELAIDE, S.A. 5000.

For further information and data sheets contact your local distributor.

NSW: Mayer Krieg (02) 684 1900;
M. Ruffy (02) 476 4066.

NEWCASTLE: DGE Systems (049) 69 1625

QLD: E.C.Q. Electronics (07) 376 5677;

Fred Hoe (07) 277 4311.

SA: Anelco Electronics (08) 294 2600.

VIC: Mayer Krieg (03) 579 5722.

WA: Pro-Spec Distributors

(09) 362 5011.

NZ: Channelmaster (9) 59 9003.

What is better than NiCad for memory back-up?

NEC



COMPARATIVE SIZE

SUPERCAP of course!

Unlike NiCad —

- It never needs replacing or maintenance.
- It does not exhibit discharge memory.
- It can be wired either way. Lack of polarity enables this.
- It can be soldered onto P.C.B.s with other components.
- It can be charged at high and low current rates, i.e. microamps to amps.
- It is completely safe. It will not explode under extremes of temperature, nor will it leak.
- It is small and compact.

Catalogue No.	Cap. (Farad)	Rated V. (V.D.C.)	Max. W.V. (V.D.C.)	Max. ESR* (Ω at 1 kHz)
FA0H105Z	1.0	5	5.5	2.5
FZ0H223Z	0.022	5	5.5	50
FZ0H473Z	0.047	5	5.5	40
FZ0H104Z	0.1	5	5.5	45
FZ0H224Z	0.22	5	5.5	25
FZ0H474Z	0.47	5	5.5	13
FZ0H105Z	1.0	5	5.5	7

*Equivalent series resistance

TECHNICAL INFORMATION AVAILABLE ON REQUEST. JN

SOANAR

SOANAR ELECTRONICS PTY. LTD.
INCORPORATED IN VICTORIA
30-32 Lexton Road, Box Hill, Vic., 3128, Australia.

VICTORIA: 895 0222
N.S.W.: 789 6744
Sth. AUST. 297 0811

QUEENSLAND: 852 1133
WEST. AUST.: 381 9522
TASMANIA: 31 6533

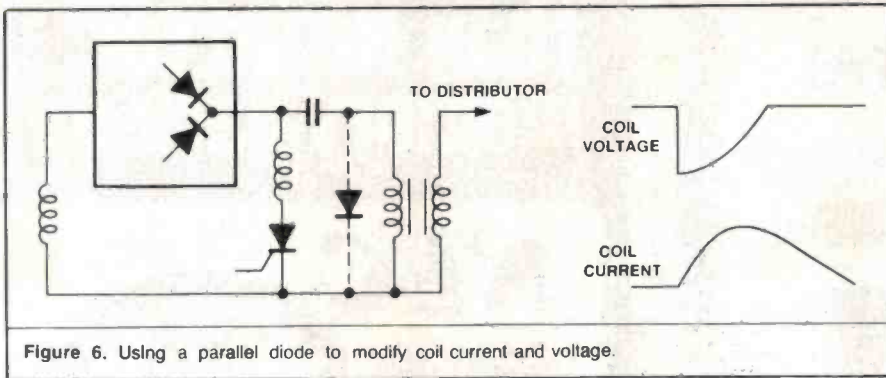

Figure 6. Using a parallel diode to modify coil current and voltage.

verter-rectifier-SCR-coil combination must be as shown in Figure 6. In the final design D1 is the rectifier diode, Q4 is the dump SCR and C2 is the dump capacitor. As long as D1 points the right way (it does) C2 will charge correctly. The only effect of moving the diode is that the secondary winding of the inverter operates at the dc voltage of C2 instead of ground (take note when deciding how much insulation is required). For the moment assume L2 and R16 are shorted out and C5 is removed. After capacitor charging is completed the inverter coil secondary, the anode of Q4 and the cathode of D1 are all at 300 volts. When the SCR, Q4 is triggered on to start the dump cycle it imposes the full 300 volts across the inverter coil secondary and the other side of the secondary starts to drive the dump capacitor negative. Everything proceeds as before *except that the output to the ignition coil is driven through 550 microhenries*. The very low impedance of the SCR is buffered by the inverter coil secondary. This means we are free to put components in parallel with the ignition coil to shape and tailor the rise time on the coil primary *exactly as we desire*. In the final design I chose to use a 150 nF capacitor so the rise time for the ignition coil primary is set by the inverter coil secondary and C6. For purposes of calculating output rise time the ignition coil can be treated as an open circuit (it's very large) and the dump capacitor can be treated as a short circuit (it's also very large). The rise time is completely controlled by the inverter secondary resonating with C6. To stop the two ringing a resistor R19 is included in series with C6 to complete the shaping of the rising edge of the voltage applied to the coil. All problems solved!

Moving the SCR to the other side of the inverter secondary has some other desirable features too. If the inverter is still charging the capacitor when the SCR is triggered, then the SCR immediately turns the inverter off as it forces 300 volts across the coil secondary which turns the base winding for the inverter off. This ensures that if there is ever any dispute for control of the inverter coil the SCR wins!

This solution did give a few problems and these are the reason for L2, R16 and C5. Since the C2 side of the inverter secondary

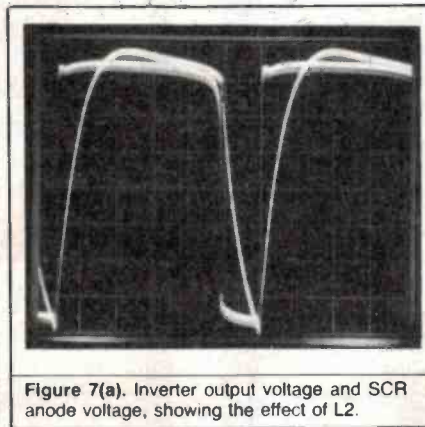

Figure 7(a). Inverter output voltage and SCR anode voltage, showing the effect of L2.

has only the steady state charging voltage on it all the switching voltage of the inverter appears on the anode of Q4 (see Figure 7(a)). This means that the SCR anode has a very large changing voltage applied to it. An SCR, like any other device has stray capacitances between anode and PNP base, and PNP base and NPN base (refer to Figure 2 again). If the anode is driven positive very fast then capacitive currents are induced in both bases of the four layer structure. The SCR cannot distinguish between capacitive currents and gate trigger currents and so if the anode voltage changes too fast then the SCR will turn on. The manufacturers specify this effect as the maximum rate of change of off state voltage or off $\frac{dV}{dt}$ and for most el cheapo SCRs it is usually a minimum of only 10 V/ μ s — trouble! RCA (which seems to be pretty good at making power semiconductors) makes a device with an off $\frac{dV}{dt}$ of 100 V/ μ s which is the S5800 series. Lo and behold they were available in Australia!

One hundred volts per microsecond still isn't anywhere good enough but it gave me a chance! To completely solve the problem I had to use the old 'saturating inductor snubber trick'. This works as follows. L2 is an inductor wound on a toroid with very high permeability and R16 in parallel with it makes a very low Q inductor assembly. In fact its Q is so low that it forms a critically damped resonant circuit with C5 and the SCR strays (about 100 pF). This means that

when the inverter secondary applies a sub-microsecond square wave edge to the input of L2 and R16 the SCR only sees a controlled rising edge of (surprise! surprise!) 100 V/ μ s. Because R16 makes the LCR network critically damped there is no ringing and the SCR is happy (and so, presumably, are we).

But what happens when the SCR is triggered? While it is possible to make quite large inductance values with a toroidal core they are very easy to saturate with direct currents. When the SCR is off no dc can flow and the toroid passes only the small amount of ac needed to charge C5 and the SCR strays. When the SCR is triggered the resultant dc saturates the toroidal core in three or four microseconds and the inductance almost completely disappears. Clever eh? More than that it works just fine! This really completes the discussion of the basic shaped pulse CDI; the design gave me complete control over all parameters of the output spark. The system is completely insensitive to the type of ignition coil used, any sort at all will work well. In general if you have a coil with a ballast resistor for start boost it will work better if the resistor is not included but leave it in if you want. The current rundown is predominantly damped by the secondary spark voltage reflected into the primary.

Once the basic system was working fine I started to consider all the 'bells and whistles' that would be nice. The first to go in was to give the inverter some boost during engine starting. The final charge voltage on the dump capacitor is determined only by R4, R5 and R6 together and the zener diode ZD2. When the cathode of ZD2 is raised to about 10 volts through R4 it turns on Q3 and stops the inverter. R5 and R6 form a potential divider with R4. If R6 is shorted out the input to R4 must go more positive before ZD2 starts to turn on. Q5 does exactly this when the starter voltage is applied through the input network to its base and the output of the inverter goes up to somewhere over 400 volts during starting. This pushes the rating of the S5800D SCR so I don't recommend you use it this way all the time but for short periods it's OK.

The next nicety to be incorporated arose because of the remarkable performance of the final inverter. The final inverter would charge the dump capacitor to 300 volts from an input supply of 1.8 volts. It took a while to get there (see 'Testing') but get there it did! This was wonderful but there weren't enough volts to reliably trigger the SCR. Ridiculous! All those ergs there and no way to get at them! One of the nice things about a flyback inverter is that if several output windings are wound on the coil they all give output voltages related to each other by only their turns ratios. So three quick turns around the core, a five cent diode and a 20c capacitor and a regulated 20 volt rail was available to fire the SCR. This also ensured that an optimum trigger pulse could be applied no matter what the supply voltage.

One very nasty possibility did occur to me. Inside the inverter there is a diode directly across the output to the coil. If the 'earthy' side of the output to the coil was directly connected to ground and some misguided individual connected the hot output to the battery supply then the diode would be destroyed. It's big but not that big. To stop this possibility I connected the output ground to earth through a resistor (R18 on the circuit diagram). This would have almost no effect on the inverter regulation but very nicely prevents any mishaps. Since the secondary and primary sides of the inverter were no longer tied together this required a little thought concerning triggering. As the energy to trigger the SCR is referred to the secondary ground an optocoupler ensured that no matter what was done triggering would always happen when wanted and, better, wouldn't happen if not wanted due to stray currents in R18.

Very little modification is needed to make the circuit operate from a Hall effect sensor. A little performance is lost as the Siemens HKZ101 won't work on less than 4.5 volts but all that's needed is to change R13 from the 47 ohms for points to 300 ohms and replace the 180 ohm R14 with a 22 ohm resistor. Thus when the points input is open circuit (or off for the HKZ101) at least 8 mA flows into the optocoupler at the lowest supply voltage. R20 provides the recommended current limiting for the sensor as per data sheet.

Testing the prototype

After a certain amount of fiddling around with a rats nest, I built a prototype and had the wonderful experience of having everything work almost perfectly the first time. The board layout had no errors (amazing!) and the whole thing just happened. I had an ignition coil that I'd used on the development of the earlier CDI built some years ago that served just fine for testing. It has a primary resistance of 3 ohms and a turns ratio of near enough to 100:1.

The first thing to do was ensure that all the calculations about arc duration were correct. Photographs were taken with the coil and CDI rigged up on the bench. A rats nest version of a transistor assisted ignition was also built for comparison purposes. Calculations for the transistor assisted ignition said that the rate of rise of primary voltage should be about $15 \text{ V}/\mu\text{s}$ and the tests confirmed this exactly. For the CDI I had already done the design for a rate of rise (in this case fall — the pulse is negative for the CDI) of twice this value as there is a compromise between fast voltage change firing dirty plugs and the risk of cross firing. Figure 7(b) shows that, once again the calculations were spot on. The negative going pulse leading edge has a $\frac{dv}{dt}$ of so near $30 \text{ V}/\mu\text{s}$ as not to matter. The photograph also shows that the coil secondary voltage also changes nearly twice as fast for the CDI.

The arc duration was measured for the

CDI and the result is shown in Figure 7(c). The timebase for the CRO was changed to 100 microseconds/division and the arc duration was measured at 0.75 ms. This is almost exactly the same as is obtained in the currently fashionable transistor assisted ignition except that the CDI will maintain this arc duration up to 330 pulses per second with no reduction in spark power at all. This corresponds to an engine speed of 5000 rpm in my trusty V8 or 10 000 rpm in a four cylinder car. A transistor assisted ignition with dwell extension can equal this performance but only at the expense of very high coil currents. The pulse shaped CDI draws about 5 amps at these unrealistically high speeds and for normal driving usually draws about one amp.

The next point of interest with the CDI system is the coil secondary voltage and current. Figure 7(d) shows how these parameters vary with time during the spark. The lower trace is the secondary voltage and the upper trace is the current. It can be seen that before gap breakdown no current flows (reasonable!). After the gap arcs over, the gap voltage drops to about 1 kV and the current rises in a sine wave following the primary resonance of C2 and the coil primary. The secondary current peaks at about 70 mA when D10 turns on and shorts out the primary. After this the coil primary and secondary currents decay away to zero. When the secondary current reaches zero the arc is extinguished and the small amount of energy left in capacitances rings. This confirmed that all was happening as designed for in the system.

To show how the inverter works a photograph (Figure 7 [e]) is also given of the collector waveform for Q1. These pictures correspond to an engine speed of about 2600 rpm for a V8 or 5400 rpm for a four cylinder and so are representative. In the test fixture the dwell angle was 50 per cent as a square wave was used to trigger the system. The photograph shows the inverter recharging the capacitor in two milliseconds then shutting down. The rather ragged waveform a millisecond after the inverter shuts down is the CDI triggering, and voltage is due to C2 discharging through the inverter secondary being reflected back into the primary circuit. When Q1 is off its collector voltage sits at the supply voltage. It's interesting to note that the supply rail is being pulled down by the inverter when it's running and takes several milliseconds to recover. This is because rather light leads were used in the test fixture. It illustrates that when the unit is installed in a car good solid supply lines should be used.

A rough estimate of inverter efficiency was made by accurately measuring the value of C2 then measuring the current drawn by the inverter for exactly 100 pulses per second. The power out of the inverter is $\frac{1}{2}CV^2 \times 100 = 11.8 \text{ W}$. To produce this output 1.4 A was needed from a 12 volt rail which gives an efficiency of 70 per cent but there are many uncertainties in the measurement.

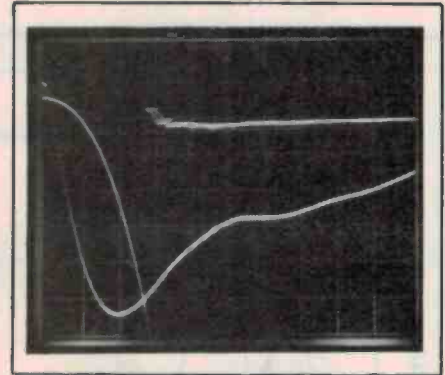

Figure 7(b). Coil primary (lower) and secondary voltage for the new CDI. Time $10 \mu\text{s}/\text{div}$, prim $50 \text{ V}/\text{div}$, sec $2 \text{ KV}/\text{div}$.

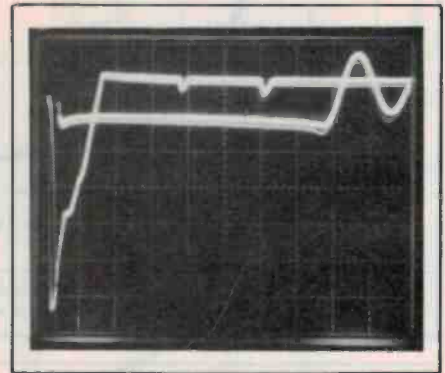

Figure 7(c). As above, but with $100 \mu\text{s}/\text{div}$ to show arc duration.

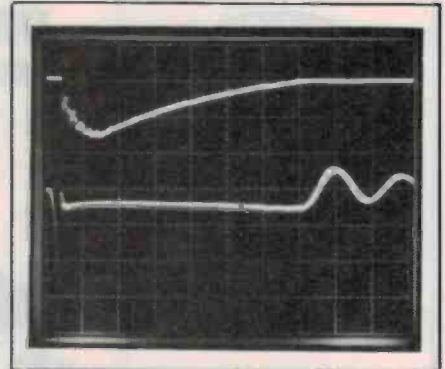

Figure 7(d). Coil secondary current (top, $50 \text{ mA}/\text{div}$) and voltage (bottom, $2 \text{ KV}/\text{div}$).

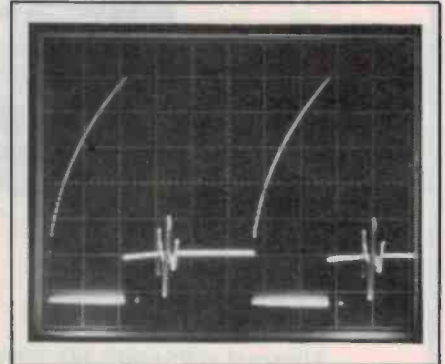
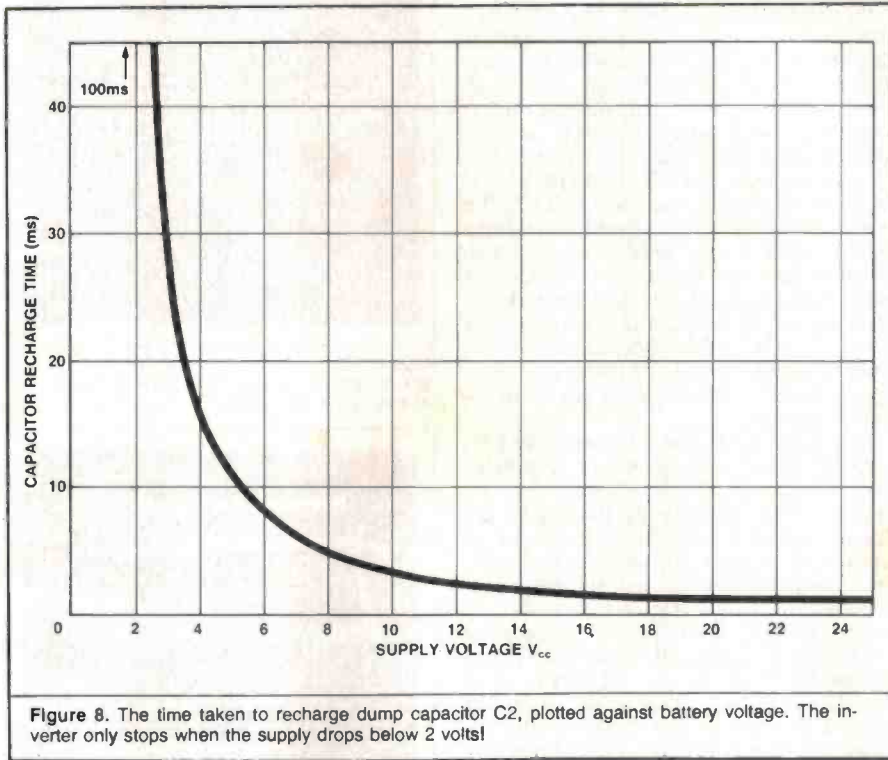

Figure 7(e). The waveform at Q1's collector ($10 \text{ V}/\text{div}$, $1 \text{ ms}/\text{div}$).



Finally the time taken for the inverter to recharge C2 was measured as a function of the supply voltage and the results are shown in Figure 8. For normal operating voltages of 13.6 volts the capacitor is recharged in two milliseconds but even if the voltage drops to 7 or 8 volts (not unusual during starting in winter) the inverter still gives full spark power after five milliseconds. At 25 volts in (don't ask me how you'd ever get this supply voltage in a 12 volt system) the inverter recharged the capacitor in one millisecond.

The inverter stopped operating at about 1.9 volts and at just over 2 volts was still giving the full 300 volts out. It's hard to imagine how you'll start an engine with the battery this flat but it's nice to know that the ignition system isn't the cause of the engine not starting!

Just to satisfy myself that the design was right I operated the CDI in an oven at 70°C for half an hour. This was a far more severe test than was ever expected in real life as the hot air in the oven wasn't moving and made heat dissipation a major problem for the CDI. Nonetheless the system came through with flying colours. However, I can't emphasise enough that if you build the CDI up it's *far* better to mount it under the dash or somewhere else that's cool.



IMMEDIATE DELIVERY
FROM STOCK AT THE FOLLOWING LOCATIONS

PROUDLY AUSTRALIAN 

Australian Connector
Manufacturers for
over 30 years.

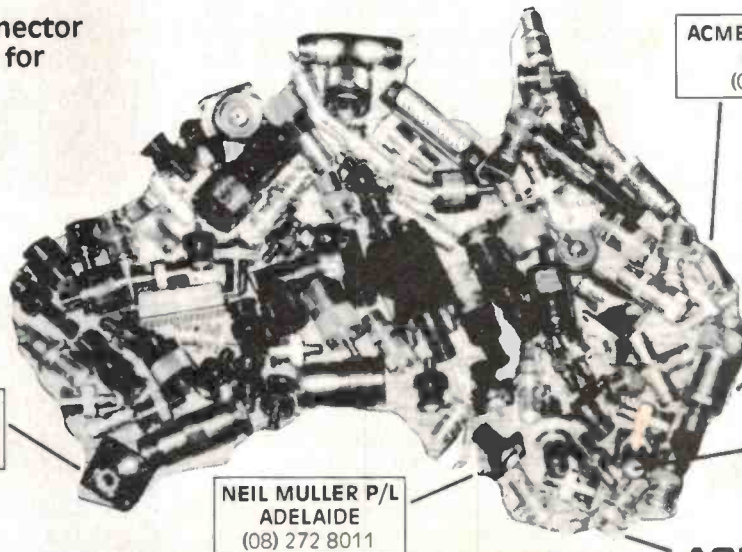

ACME ELECTRONICS
BRISBANE
(07) 44 4131

ACME ELECTRONICS
SYDNEY
(02) 648 2255

ELECTRONIC
COMPONENTS
(062) 80 4654

J.G. THOMAS
PERTH
(09) 272 7122

NEIL MULLER P/L
ADELAIDE
(08) 272 8011

W.P. MARTIN
HOBART
(002) 34 2811

ACME ELECTRONICS

205 Middleborough Road,
Box Hill, Victoria, 3128, Australia
Tel: (03) 890 0900 Telex: AA37857

A Division of JAMES HARDIE INDUSTRIES
(Hardie Trading Ltd. - Inc. in Vic.)

KITS from Rod Irving Electronics — the kit specialists!

★★ RECENT RELEASES★★



ELECTRONIC MOUSETRAP

This clever electronic mousetrap disposes of mice instantly and mercifully without fail, and resets itself automatically. They'll never get away with the cheese again! (ETI Aug '84).

Cat. ETI 1524 \$29.95



SOUND SIMULATOR FOR MODEL TRAINS

Fancy a diesel sound simulator for your model train layout? This circuit mounts inside the train for added realism and even varies its 'speed' according to the throttle setting. (EA Nov '84).

\$18.00



1W AUDIO AMPLIFIER

A low-cost, general-purpose, 1 watt audio amplifier, suitable for increasing your computers audio level, etc. (EA Nov '84).

\$9.95

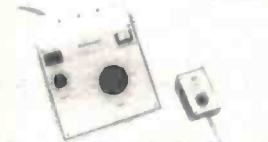

RAILMASTER PULSE POWER TRAIN CONTROLLER

Here's an up-to-the-minute train controller offering all the most desirable features including inertia, full overload protection, walk-around throttle and excellent low-speed running characteristics. Probably the best controller available, regardless of the cost! (EA Sept '84 841c9)

Cat. K84091 \$79.50



COMPUTER DRIVEN RADIO-TELETYPE TRANSCIVER

Here's what you've all been asking for — a full transmit-receive system for a computer-driven radio teletype station. The software provides all the latest "whizz-bangs" like split-screen operation, automatically repeating test message, printer output and more. The hardware uses tried and proven techniques. While designed to team with the popular Microbee, tips are available on interfacing the unit to other computers. (ETI Nov '84, ETI-755)

Cat. K47550 \$139.00



DRUM SYNTH. MODULE

A simple, low-cost Module that will generate a wide variety of drum-like sounds from a pulse input provided from a sound pick up or electronically. (ETI Oct '84).

ETI-610 \$24.95



SOLAR POWERED HOUSE NUMBER

Searching for a house at night in an unfamiliar street can be a frustrating business. This illuminated house-number switches itself on at dusk and switches off six hours later. (EA Sept. '84, 84M8B)

Cat. K84092



EA AM STEREO DECODER

AM stereo is now broadcast in Australia on an experimental basis. This add-on decoder works with the Motorola C-QUAM system. (EA Oct. '84, 84MS10)

Cat. K84101 \$24.95



READY-SET-GO LIGHTS

A simple project for starting slot car races, etc. It provides the traditional Red/Amber/Green lights with a random delay between the amber and green. (ETI Oct '84).

ETI-277 \$24.95



150 W BASS AMP

This guitar amp for impeccable bass players features many facilities found on expensive 'commercial' ones. It delivers 150 watts into 4 ohms, has a t-band graphic, limiter, line out and bi-amp facilities. (ETI Aug. '84, ETI-1410)

Cat. K54100 \$299.00



DIRECTIONAL DOOR MINDER

Most electronic door minders function by having a beam of light shining across a doorway interrupted, but are incapable of detecting whether the light beam is broken by a person entering or leaving the room. This project overcomes that problem with the aid of digital logic. (ETI Nov. '84, ETI 278).

Cat. K42780 \$29.95



EFFECTS UNIT

An 'effects unit' that can create phasing, flanging, echo, reverb and vibrato effects. (EA June '83).

83GA6 \$65.00



INVERTER

This 12 240V inverter can be used to power mains appliances rated up to 40W, or to vary the speed of a turntable. As a bonus, it will also work backwards as a trickle charger to top up the battery when the power is on.

(EA May '82) \$49.50



CUDLIPP CRICKET

A fascinating Electronic Cricket with just two ICs. The Cudlipp can be used to bug your home, office etc! Great fun! (EA Feb. '82).

Cat. 82EG2 \$12.00



ELECTRONIC WATT METER

This unit will measure the power consumption of any mains appliance with a rating up to 3 kilowatts. It makes use of a special op amp called an 'output transconductance amplifier' or OTA, for short. (EA Sept. '83).

Cat. 83WM8 \$79.50



PH METER KIT

Build this pH meter for the swimming pool season is here again! From swimming pools to fish tanks to gardening, this pH meter has many applications around the home. This unit features a large 3 1/2 digit liquid crystal display and resolution to .01pH units, making it suitable for use in the laboratory as well. (EA Dec. '82).

Cat. 82PH12 \$139.00

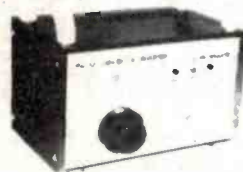

12-230V DC-AC INVERTER

INCLUDING TRANSFORMER 300 WATTS

This EA Inverter is capable of driving mains appliances rated up to 300VA and features voltage regulation and full over load protection. (EA June '87).

Nominal Supply Voltage 12V DC
Output Voltage see table
Frequency 50Hz±.005%
Regulation see table
Maximum Load 300VA
Current Limiting 30A (primary)
Efficiency see table

P & P \$10.00. Anywhere In Australia. \$195.00



30 V/1 A FULLY PROTECTED POWER SUPPLY

The last power supply we did was the phenomenally popular ETI-131. This low cost supply features full protection, output variation from 0V to 30V and selectable current limit. Both voltage and current metering is provided. (ETI Dec. '83).

ETI-162 \$49.50

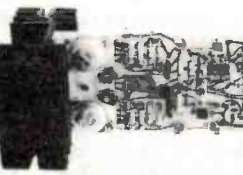

50 W AMPLIFIER MODULE

Cat. K44800 \$24.50

100 W AMPLIFIER MODULE

Cat. K44801 \$27.50



HUMIDITY METER

This project can be built to give a readout of relative humidity either on a LED dot-mode display or a conventional meter. In addition it can be used with another project as a controller to turn on and off a water mist spray in a hothouse, for example. (ETI May '81).

(Includes humidity sensor. \$19.50).

Cat. K42560 ETI256 \$29.50



TEMP PROBE

Can measure temperature from -50° to +150°C. It simply plugs into your multimeter — great for digital multimeters. Accuracy of 0.1°C resolution of 0.1°C. (ETI June '83).

ETI-153 \$22.50



ELECTRIC FENCE

Mains or battery powered, this electric fence controller is both inexpensive and versatile. Based on an automotive ignition coil, it should prove an adequate deterrent to all manner of livestock. Additionally, its operation conforms to the relevant clauses of Australian Standard 3129. (EA Sept. '82).

82EF9 \$19.50



LOW OHMS METER

How many times have you cursed your Multimeter when you had to measure a low-value resistance? Well with the "Low Ohms Meter" you can solve those old problems and in fact measure resistance from 100 Ohms down to 0.005 Ohms. (ETI Nov. '81).

ETI-158 \$34.50

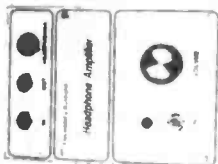

HEADPHONE AMPLIFIER

PRACTISE WITHOUT ANNOYING THE FAMILY! If you play any type of electronic instrument, this headphone amplifier will surely interest you. It will let you practise for hours without upsetting the household, or you can use it to monitor your own instrument in the midst of a rowdy jam session. (EA Feb. '84).

83MA11 \$28.00



MOSFET POWER AMPLIFIER

Employing Hitachi Mosfets, this power amplifier features a 'no compromise' design, and is rated to deliver 150% W RMS maximum and features extremely low harmonic, transient and intermodulation distortion. (ETI Jan. '81).

Cat. ETI 477 \$63.00



PARABOLIC MICROPHONE

Build a low cost parabola, along with a high gain headphone amplifier to help when listening to those natural activities such as babbling brooks, singing birds or perhaps even more sinister noises. The current cost of components for this project is around \$15 including sales tax, but not the cost of batteries or headphones. (EA Nov. '83)

83MA11 \$15.00



MODEL ENGINE IGNITION SYSTEM

Get sure starts every time and no more glow plug burnouts on your model engines. (ETI June '83)

ETI-1516 \$41.50



CAR IGNITION KILLER

Most car burglar alarms are easily circumvented, but not this cunning "Ignition Killer". This sneaky anti-theft device uses a 555 timer to place an intermittent short circuit across the points. Until disabled by its hidden switch the circuit effectively makes the car undrivable — a sure deterrent to thieves! (EA Feb. '84)

84AU1 \$16.95
(Our kit includes the box!)



LOW OHMS METER

How many times have you cursed your Multimeter when you had to measure a low-value resistance? Well with the "Low Ohms Meter" you can solve those old problems and in fact measure resistance from 100 Ohms down to 0.005 Ohms. (ETI Nov. '81)

ETI-158 \$34.50

VIDEO AMPLIFIER



Bothered by smeary colours, signal beats and RF interference on your computer display? Throw away that cheap and nasty RF modulator and use a direct video connection instead. It's much better! The Video Amplifier features adjustable gain and provides both normal and inverted outputs. Power is supplied from a 12V DC plugback supply. (EA Aug. '83)

83VA8 \$15.00



MOSFET POWER AMPLIFIER

Employing Hitachi Mosfets, this power amplifier features a 'no compromise' design, and is rated to deliver 150W RMS maximum and features extremely low harmonic, transient and intermodulation distortion. (ETI Jan. '81)

Cat. ETI 477 \$63.00

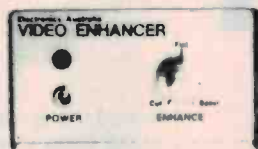

VIDEO ENHANCER 100's SOLD

Like tone controls in a hi-fi amplifier, touch up the signal with this Video Enhancer. (EA Oct. '83)

83VE10 \$35.00



RADIOTELETYPE CONVERTER FOR THE MICROBEE

Have your computer print the latest news from the international shortwave news service. Just hook up this project between your shortwave receiver's audio output and the MicroBee parallel port. A simple bit of software does the decoding. Can be hooked up to other computers too.

(ETI Apr. '83) \$20.00

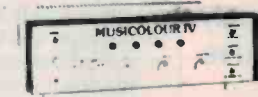

MUSICOLOR IV

Add excitement to parties, card nights and discos with EAs Musicolor IV light show. This is the latest in the famous line of musicolors and it offers features such as four channel "color organ" plus four channel light chaser, front panel LED display, internal microphone, single sensitivity control plus opto-coupled switching for increased safety. (EA Aug. '81)

81MC8 \$84.00



FUNCTION GENERATOR

This Function Generator with digital readout produces Sine, Triangle and Square waves over a frequency range from below 20Hz to above 160Hz with low distortion and good envelope stability. It has an inbuilt four-digit frequency counter for ease and accuracy of frequency setting. (EA April '82)

82AQ3A/B \$79.50



MOTORCYCLE INTERCOM OVER 300 SOLD!

Motorcycling is fun, but the conversation between rider and passenger is usually just not possible. But build this intercom and you can converse with your passenger at any time while you are on the move. There are no "push-to-talk" buttons, adjustable volume and it's easy to build! (EA Feb. '84)

84CM5 \$45.00



TRANSISTOR TESTER 1000's SOLD

Have you ever desoldered a suspect transistor, only to find that it checks OK? Trouble-shooting exercises are often hindered by this type of false alarm, but many of them could be avoided with an "in-circuit" component tester, such as the EA Handy Tester. (EA Sept. '83)

83TT8 \$15.00



LAB SUPPLY

Fully variable 0-40V current limited 0-5A supply with both voltage and current metering (two ranges: 0-0.5A/0-5A). This employs a conventional series-pass regulator, not a switchmode type with its attendant problems, but dissipation is reduced by a unique relay switching system switching between taps on the transformer secondary. (ETI May '83)

ETI-163 \$175.00



SLIDE CROSS-FADER

Want to put on a really professional slide show? This slide cross-fader can provide smooth dissolves from one projector to another, initiate slide changing automatically from an in-built variable timer, and synchronise slide changes to pre-recorded commentary or music on a tape recorder. All this at a cost far less than comparable commercial units. (EA Nov. '81)

81SS11 \$85.00

EPROM PROGRAMMER EP1



No need for a Micro with EA's great Eprom Programmer suitable for 2716/2758 Eproms. (EA Jan. '82)

82EP1 \$47.50
With Textool Sockets \$59.95



PHONE MINDER

Dubbed the Phone Minder, this handy gadget functions as both a bell extender and paging unit, or it can perform either function separately. (EA Feb. '84)

84TP2 \$24.00



MICROBEE SERIAL-TO-PARALLEL INTERFACE

Most Microcomputers worth owning have an 'RS232' connector, or port, through which serial communications (input/output) is conducted. It is a convention that for listing on a printer, the BASIC LLIST or LPRINT command assumes a printer is connected to the RS232 port. Problem is, serial interface printers are more expensive than parallel 'Centronics' interface printers. Save money by building this interface. (ETI Jan. '84)

ETI-675 \$55.00

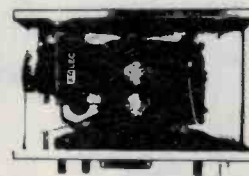

DUAL TRACKING POWER SUPPLY

Built around positive and negative 3-Terminal Regulators, this versatile dual tracking Power Supply can provide voltages from $\pm 1.3V$ to $\pm 22V$ at currents up to 2A. In addition, the Supply features a fixed +5V 0.9A output and is completely protected against short circuits, overloads and thermal runaway. (EA March '82)

82PS2 \$87.50



BIPOLAR PROM PROGRAMMER

Every digital workshop should have one! Can be used to program the popular fusible-link PROMS like the 74S188/288, 82S23 and 82S123 etc. (ETI June '83)

ETI-688 \$47.50

ELECTRIC DUMMY LOAD



With this unit you can test power supplies at currents up to 15 Amps and Voltage up to 60 Volts. It can "sink" up to 200 Watts on a static test and you can modulate the load to perform dynamic tests. (ETI Oct. '80)

ETI-147 \$99.00

Errors and Omissions Excepted

rie

Rod Irving Electronics

425 HIGH STREET,
NORTHCOTE VICTORIA.
PH:(03)489 8866 489 8131
48-50 A'BECKETT STREET,
MELBOURNE VICTORIA.
PH:(03)347 9251
Mail Order and
correspondance:
P.O. Box 235
NORTHCOTE 3070

Call in at either 2
of our convenient-
ly located stores:
48-50 A'Beckett
St., Melbourne
425 High St.,
Northcote.
Or take advantage
of our Mail
Order Department.
Write to:

MAIL ORDER CENTRE
ROD IRVING ELECTRONICS
P.O. BOX 235
NORTHCOTE 3070

or phone ...
MAIL ORDER
HOT LINE



(03) 481 1436



POSTAGE RATES
\$1-\$9.99 \$1.50
\$10-\$24.99 \$2.00
\$25-\$49.99 \$3.00
\$50-\$99.99 \$3.50
\$100-\$199 \$5.00
\$200-\$499 \$7.50
\$500 plus \$10.00

Comet road freight is extra.

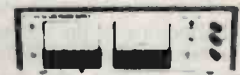

50V 5A LABORATORY POWER SUPPLY

New switchmode supply can deliver anywhere from three to 50V DC and currents of 5A at 35V or lower. Highly efficient design. (EA May, June '83)

83PS5 \$140.00



ZENER TESTER

A simple low cost add-on for your multimeter. This checks zeners and reads out the zener voltage directly on your multimeter. It can also check LEDs and ordinary diodes. (ETI May '83)

ETI-164 \$9.50

PRECISION CRO CALIBRATOR



Anyone who has used a CRO will know what an incredibly useful instrument it can be — providing you can be sure of its calibrations. This handy low-cost calibrator will let you check and adjust all main settings easily and efficiently. Designed by the Electrical Engineering staff at Sydney University, it is easily built and can also be used to check out a CRO you're considering buying.

WHEN OSCILLOSCOPES or 'CROs' first started to be used in electronics, they were simply used to 'look at' what was going on in a circuit. Just being able to 'see' what was happening to the voltages and currents was a big step forward from what had been possible before, and for a while that was enough.

But nowadays people expect to be able to use a CRO in a much more quantitative fashion, to measure instantaneous voltages, voltage changes and timing details. In order to be used in this more serious way, a CRO naturally needs to be properly calibrated.

The small low-cost calibrator described here has been designed to make calibration of almost any reasonably modern CRO a fairly simple and straightforward job. It produces pulses of known accurate amplitude and timing, whose peak-to-peak voltage and repetition rate can be varied over a

wide range to allow most of a CRO's normal ranges to be checked.

While the calibrator can be used to check and adjust both gain and linearity for both the vertical and horizontal channels of an instrument, in practice most CROs do not provide a means of adjusting the linearity of the vertical amplifier(s) — only the gain. Similarly although you can use the calibrator to check horizontal linearity, most instruments only allow you to adjust the horizontal gain and average timebase sweep speed.

A CRO which was made more than ten years ago (fairly rare in the commercial world, but still common in hobby workplaces) can easily drift a few percent in a period of months. Hence the need for a handy reference like this calibrator.

In addition to its main intended use in keeping your existing CRO or CROs cali-

brated, it is probably also worth taking along when you are looking at new CROs with an eye to purchase. It has surprised the authors to see how badly some otherwise impressive units fared, even brand new.

We will now discuss how the calibrator is used, for those who may not have been exposed to such procedures before. In addition to checking vertical gain accuracy and sweep speed, we will also explain how to check overshoot, timebase non-linearity, the presence of a satisfactory vertical delay line for viewing non-repetitive triggering events, and vertical non-linearity.

Note that we must assume you have access to the operating manual of your CRO, for details regarding the manufacturer's recommended procedures in adjusting the instrument. This varies from instrument to instrument, and it is often important to adjust things like the vertical attenuator and timebase ranges in a particular order.

Vertical calibration

This is initially fairly simple. Referring to the first CRO screen photograph (represented in Figure 1), the instrument's appropriate present potentiometer is adjusted to obtain precisely the correct deflection. The photograph was taken on a brand new CRO on a medium voltage deflection scale, and so the trace is narrow and sharp. The adjustment should be done on the range(s) specified by the manufacturer, but the checking of calibration should be done on several of the available ranges.

Figure 2 shows the same (brand new) CRO on its most sensitive range. There are two points to note. The first is that the trace was fuzzy, primarily on account of CRO amplifier noise. This requires that the operator effect some estimate of the difference between trace centres. It is best to take one edge (in Figure 2 the lower) and adjust the vertical position so as to set the reference edge precisely on a graticule line. Then the same edge of the trace on the other part of the squarewave cycle gives the deflection.

In Figure 2 the deflection is clearly about 5.2 divisions. The second point to note is that the CRO (correct to the limit of measurement on the 50 mV/div range) is 4 per cent high on the 1 mV/div range. Thus the

need to check performance against specifications on *all* ranges is very clearly demonstrated.

Horizontal calibration

Initial sweep calibration should similarly be carried out at the sweep speed specified for the particular CRO, but a check is recommended over a wider range. Figure 3 is of a set of 10 timing pulses arrayed over a CRO screen. With the fine vertical edge of the first pulse set on the first vertical graticule line, the same part of the last pulse should align with the final graticule vertical. Even on the screen of the high quality and fast writing speed CRO used for this the intensity must be set quite high to clearly show the fast vertical edges.

Timebase Linearity

Regrettably for readers, but fortunately for ETI, we were unable to locate a CRO with bad linearity. Referring still to Figure 3, had there been a non-linearity in the sweep, it would have been evident as one or more vertical pulses not being aligned with their respective graticule lines after the horizontal calibration had set the end pulses on their respective markers. We have observed such problems even on new CROs. The calibrator prevented a poor purchase in that case!

Overshoot

This phenomenon is becoming rarer on CROs these days. The only CRO we could locate with significant overshoot proved to have neither graticule illumination for clear illustrations nor the ability to give a good look for single edge blow up.

We settled for using a 10 year old CRO — also with no graticule illumination. Figure 4 shows overshoot on the edges of the inverted timing waveforms, rather than the voltage waveforms. These were easier to trigger on than the relatively infrequent edges of the voltage calibration square-wave. The overshoot is the 'wiggle' seen at the beginning of the clear horizontal parts of the trace.

Delay Line

Figure 5 shows the rising edge of the voltage calibration waveform on a high quality oscilloscope. The trace was rather dim, because the sweep occurs only at 1 kHz, despite the sweep speed of 10 ns/div. The same edge that triggered the timebase can be seen, because the CRO contains a delay line, so that the signal is delayed for long enough (some tens of nanoseconds usually) to allow the sweep to commence before the signal is applied to the vertical deflection plates. A view such as this is impossible otherwise.

The edge is not perfect. The salient feature is a minor step-like appearance at the top of the edge. This is in fact not CRO

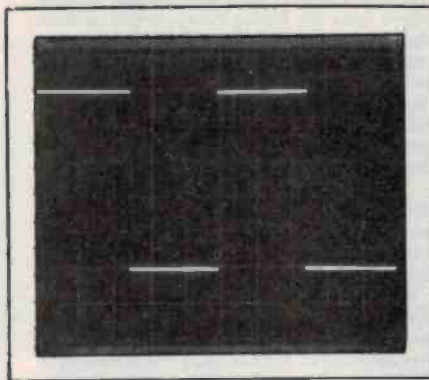

Figure 1. Vertical calibration. New Trio CS-1022 set to 0.2 ms/div, 50 mV/div.

induced overshoot, but the result of mismatch in the connection from the calibrator via a 50 ohms cable to the 1 m/50 pF input impedance of the CRO. Such is the typical situation which will be encountered.

Construction & setting up

The construction is basically a case of duplicating the prototype shown here. Initially drill the appropriate holes in the panel of the case being used. All the electronics is attached to the panel along with the switches and connectors, so the shape of the rear of the container is not important.

Once drilled, the various holes on the front label can be lined up with the holes in the panel and the label attached. After adhering the label, fit the components and their knobs where applicable. Next assemble the pc board, exercising the usual care to ensure that all the polarised components are orientated correctly. Also take care to leave the solder joints clean and free of blobs which might short tracks together. Remember that only resistors and capacitors without polarity markings can be put in either way around, because everything else is polarised in some way!

Next attach all the components which are mounted to the rear of the panel controls. These components are fixed to the panel controls to reduce the number of flying leads. Be careful to get all of them in their correct circuit locations, as reversal of components here can lead to 'satisfactory' but uncalibrated operation.

Finally connect the pc board to the panel with short lengths of hookup wire. The leads should be as short as is practicable while leaving the board accessible for alignment, servicing, etc. Long leads can give rise to unwanted coupling between the circuit sections, and may also permit the radiation of unwanted EMI (Electro-Magnetic Interference), even up to VHF frequencies, because of the sharp edges generated by the driver circuits.

With a battery connected the unit should now function. It remains only to adjust the supply to its correct voltage. This of course

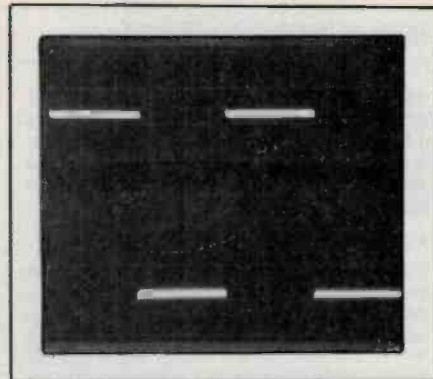

Figure 2. The same CRO as in Figure 1, at 1 mV/div.

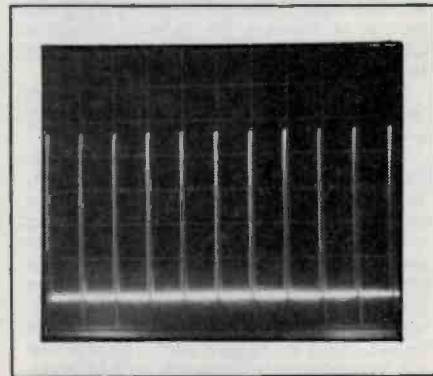

Figure 3. A seven year old Tektronix 465 is shown at 1 ms/div. Its last calibration date was not recorded, if it happened at all!

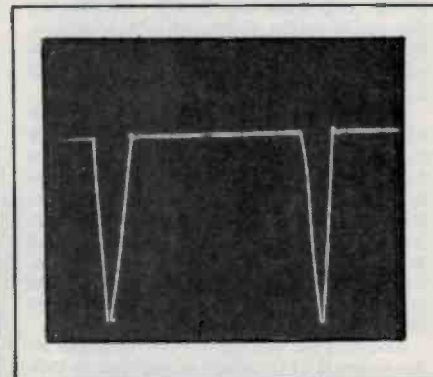

Figure 4. A BWD 511 of unguessable age. CRO calibrator set to 1µs timing pulses, CRO at 1 V/div and 0.2 µs/div. No graticule illumination available.

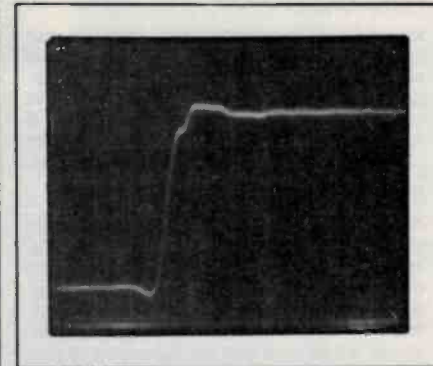

Figure 5. Tek 465 again, 20 mV/div and 10 ns/div, with the calibrator on 100 mV range.

The CRO calibrator circuit divides into six parts. These are a power supply section, a 1 MHz clock, a 10 MHz clock, a divider chain, a voltage output section and a timing pulse output section. Each will be discussed in its turn.

Power supply

The power supply consists of ICs 1, 2 and part of IC3, with their surrounding components. Q1 is used as a saturating pass element, to connect and disconnect the battery from those parts of the device which are not continuously powered. IC1 is the only IC connected all the time to the supply. Initially consider that C1 is discharged. IC1(b) and (c) have their inputs held low, so that their outputs are high. These gates are connected in parallel to increase the current delivering capacity. Because the outputs are high, Q1 is held off.

In this condition the current drain from the battery is so small that it will last its shelf life, and it may be considered unconnected.

When PB1 is depressed to turn on the instrument, C1 is charged up rapidly via R1. The inputs of IC1(b) and (c) are taken high and the outputs are thus driven low, turning on Q1. This applies almost the full battery potential to IC2, a precision supply regulator IC, via the external supply jack. Capacitors C3 and C4 decouple the rail to prevent instability problems arising from the source impedance of the battery. RV1 is used to trim the regulated supply voltage to 5.05 volts, while C5, C6 and C7 provide further decoupling and compensation.

C1 will slowly discharge via R3. When it reaches about half rail potential, IC1(b) and (c) will once again turn Q1 off, returning the instrument to the quiescent (off) condition. Thus automatic turnoff is effected. Should PB2 be fitted, it may be used to manually turn off the supply.

If the unregulated supply falls below a level where good regulation of the 5.05 volt supply by IC2 is not possible (when the battery goes flat, for example), IC3(a) and IC1(a) and (d) are wired to immediately turn the supply off. Note that IC3 is powered from the 5.05 volt rail. When the input of IC3(a) falls to below about half its supply rail, which is about 5.05 volts, it charges C2 via R5. This causes IC1(a) and (d) to discharge C1 via D1 and R2, which shuts off the supply.

Resistors R6 and R7 set the potential on the collector of Q1 which is required to initiate this automatic shutdown. This mechanism prevents any attempt to use the device when it is potentially operating incorrectly due to a low battery condition.

1 MHz Clock

The 1 MHz clock is crystal controlled and provides the timing reference for all (but the 10 MHz) timing signals and the voltage calibration squarewave. The oscillator consists of IC4(b) and surrounding components. It runs off the 5.05 volt supply, and operates continuously when the unit is in the on state.

Divider Chain

The divider chain consists of six decade counters. These provide signals divided by 10, 100, etc, up to 1 million, giving 10 per cent duty-cycle pulses of from 100 kHz to 1 Hz, all derived from the 1 MHz reference. The 'on' indicator is driven from one of these dividers, giving fast flashes with low duty cycle to give indication without wasting power.

Timing Pulse Output

IC3(b/d) and IC11 with surrounding components form the timing pulse output section. This section, when enabled, shapes the timing pulse train and delivers it to the output with 50 ohm impedance. With SW1(a) in the 'time' position, IC3(d) is enabled. The disabling system prevents the gates consuming power when not required. SW2(a) selects the timing train with the required frequency.

SW2(b) selects the capacitor which defines the shape of the output pulse. This mechanism is incorporated to provide pulses whose edges are conveniently visible on all frequency ranges.

On the 1µs range, the pulses are not modified by a capacitive load on IC11(c/d/e), but are shaped by the driving network formed by the sections of IC4 not used in the oscillator. Not only does this provide neat, visible pulses at this frequency, but it makes use of the gates in the package already handling 1 MHz signals. This reduces the chances of crosstalk between these signals, with components in very high frequency ranges, and the slower timing signals. Such crosstalk can upset triggering and interfere with the waveform being displayed.

10 MHz Clock

The 10 MHz clock circuit is built around IC12. It differs somewhat from the 1 MHz clock in order to allow clean operation at this high frequency. R39 and C18 with IC12(c/d) form the output wave of the oscillator into a pulse string for easy alignment against graticule timing marks. Note that the circuit is separately decoupled by C19, and is only powered by completing the earth return when required, as selected by the range switch SW2(b).

This circuit consumes considerable power in relation to the other parts of the calibrator, and so is not activated when not required. Its output is fed to a different connector. If it is not required, this whole section can be deleted, removing the 10 MHz 100 ns range with commensurate cost saving. If no fast CROs are likely to be encountered, this would not be a problem.

Output Section

The voltage output section, when enabled by SW1(a), produces calibrated output squarewaves at 1 kHz. The voltage level is selected by SW3. When not enabled Q2 remains off. When enabled it is switched into and out of saturation by IC11(b). Capacitor C16 is selected to precisely pull Q2 out of saturation as quickly as possible.

When fully saturated, Q2 has approximately 0.05 volts drop across it — hence the 5.05 volt supply. R16 through R36 provide a precise 1-2-5 sequence attenuator using only E12 series preferred resistor values. Signals

of 1 mV p-p to 5 V p-p are developed. The output impedance is at most a few hundred ohms. Because no buffer is provided, the CRO input must not be terminated in 50 ohms.

WHILE WE'RE TALKING ABOUT CROs . . .

While we're thinking about CROs and their performance, let's consider for a moment a few general aspects of oscilloscope or 'CRO' performance which are often taken for granted.

Nowadays there are quite a few CROs available for around the same price as a humble (humble?) audio amplifier. But we expect rather different things from the two types of equipment. For example we only expect amplifiers to have a bandwidth of from 20 Hz to 20 kHz — yet for the same money we expect a CRO to have a bandwidth of dc to 20 MHz! This is a very big difference, yet some of the better CROs go a great deal further, to 200 MHz or even 500 MHz.

Astute readers will guess at once that something is traded for this wide range. But perhaps few of you may have realised just what it is that is missing from the CRO's performance.

One of the things usually noted in the 'fine print' of CRO specifications is linearity. A vertical deflection linearity error of one or two per cent is typical, probably specified for a deflection of say six or seven major divisions.

In an audio amplifier this would be called distortion, and if it rose much above say .01%, today's audio enthusiast would be most unhappy. By paying more money, you can get an amplifier with ten times lower distortion again. In addition, the audio amp is expected to maintain this low level of distortion even at power output levels of 100 watts or so — a far cry from the few tens of volts, at low currents, expected from the CRO deflection amps.

The CRO can of course get away with this relatively poor linearity because the human eye can't perceive less than about one per cent distortion, whereas our ears most certainly can — particularly on the right kind of programme material. Round two to the audio amplifier.

In most applications where a CRO is used, the user expects to be able to resolve the position of the trace to within 0.1 divisions, on a screen with eight vertical and 10 horizontal divisions. This represents a dynamic range of about 38 dB in the vertical direction. Compare this with the 50 dB or more you get from your cassette player, or the 96 dB from a compact disc.

The upshot of this is that the signal-to-noise ratio of a CRO can be relatively poor, and the spot position uncertainty fairly large. Round three to the audio amplifier.

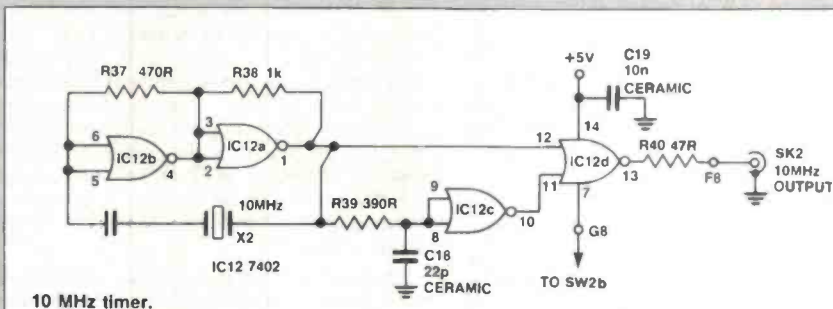

10 MHz timer.

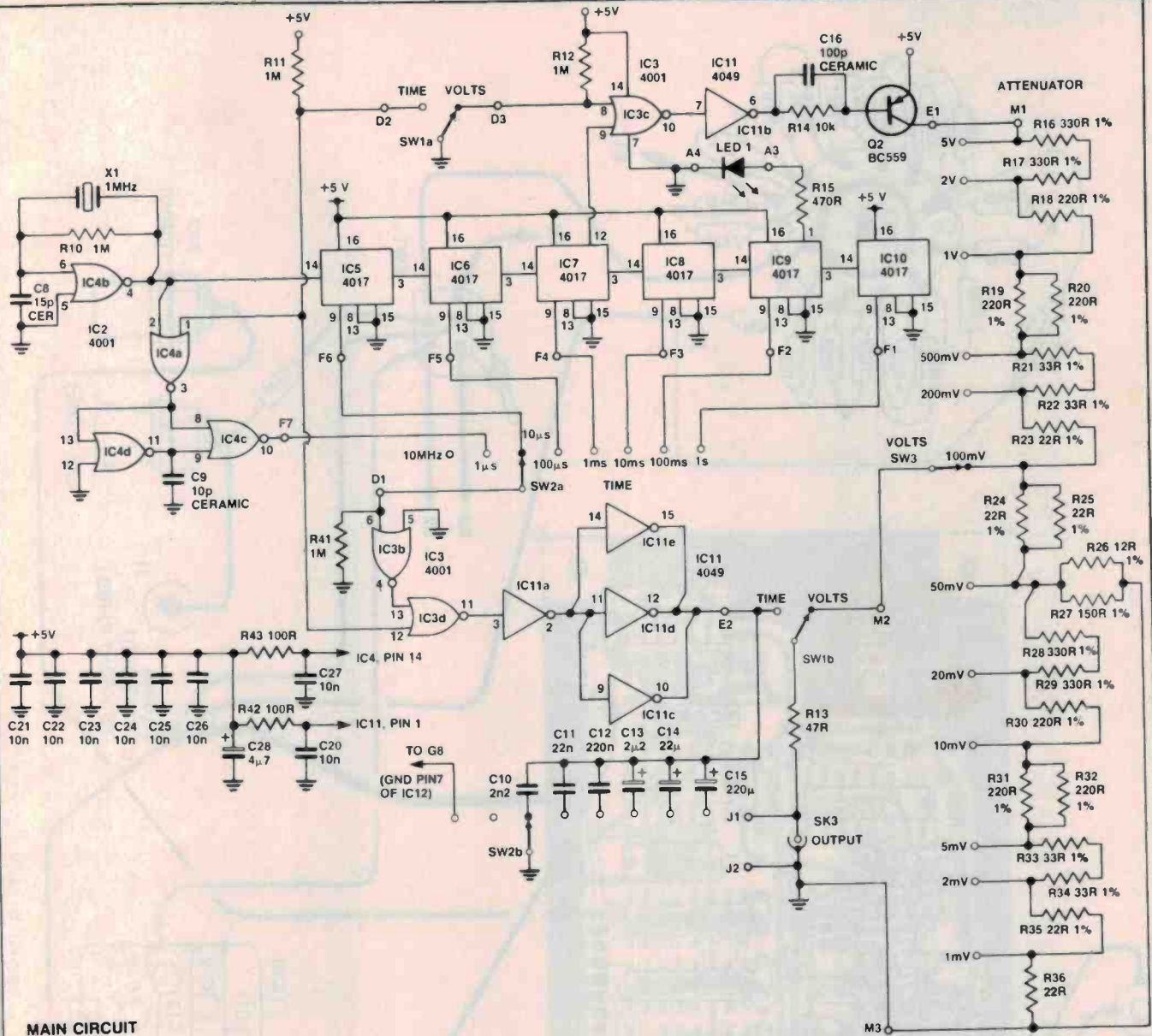

MAIN CIRCUIT

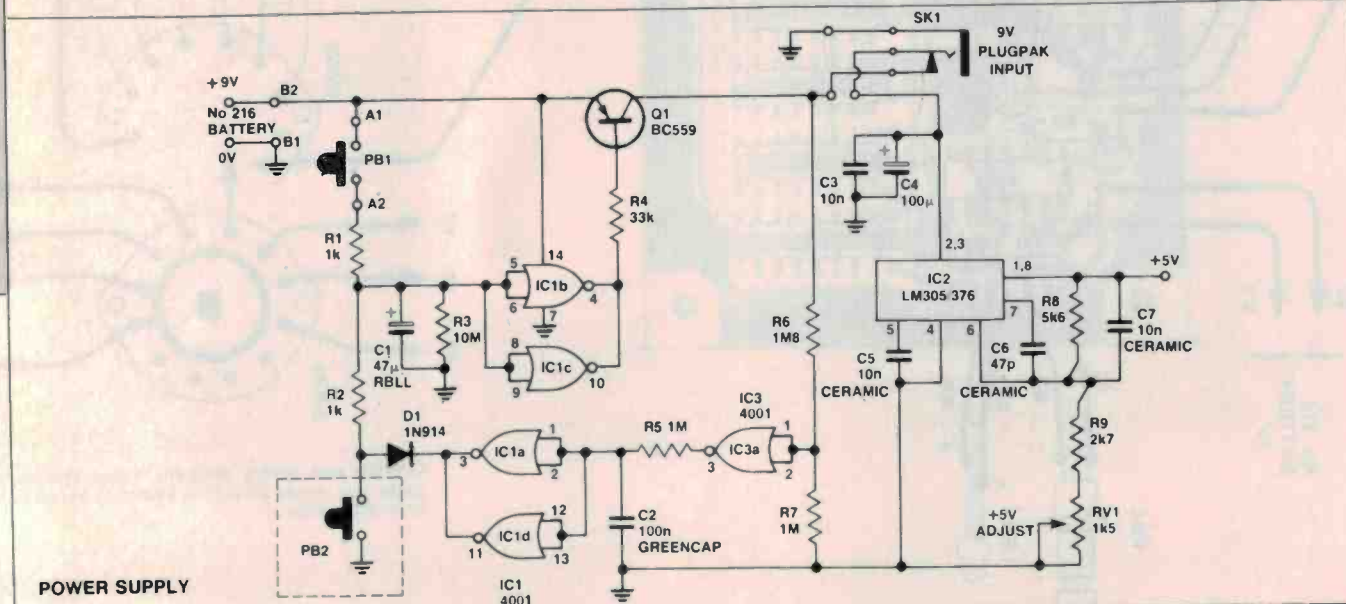

POWER SUPPLY

Project 170

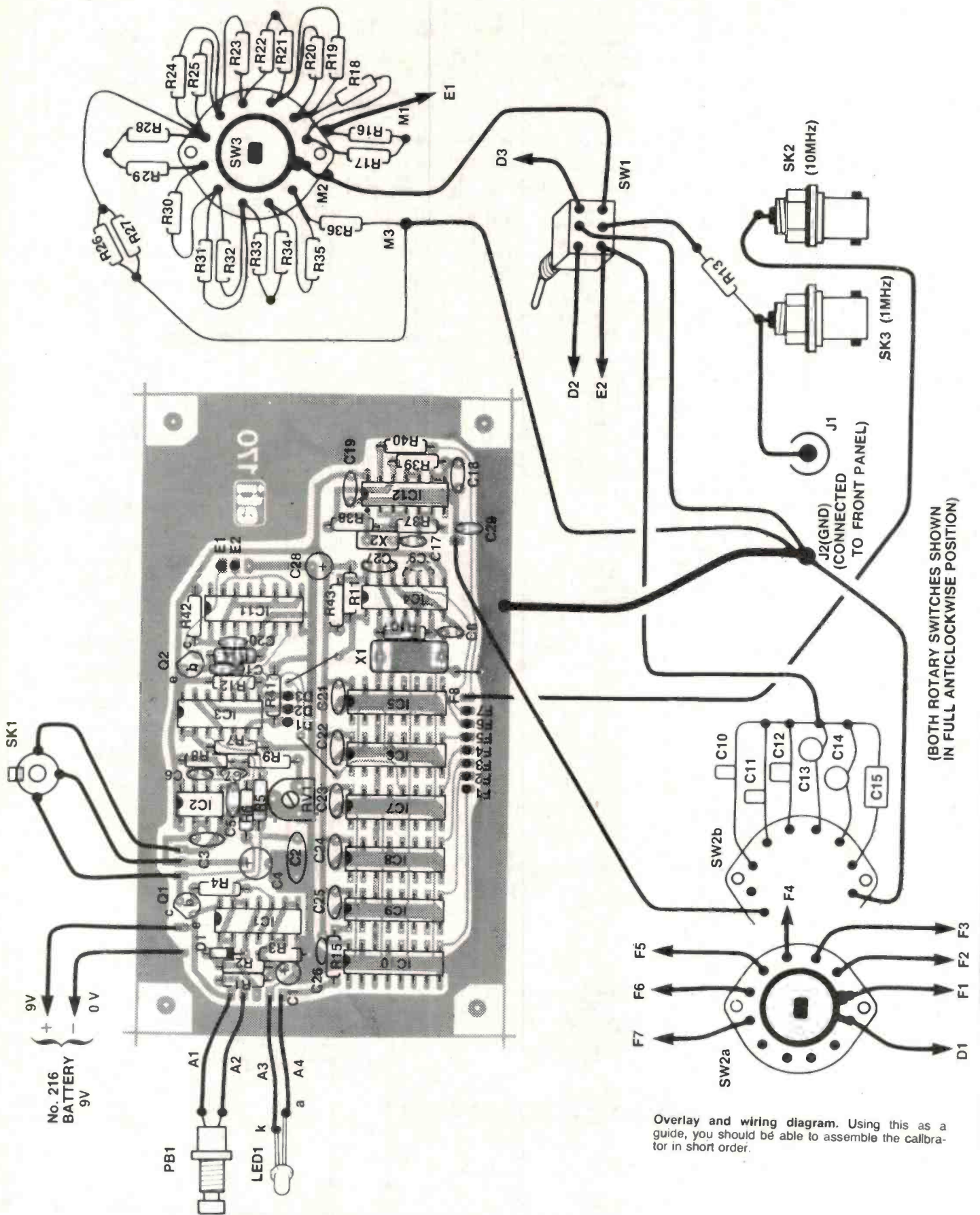

Overlay and wiring diagram. Using this as a guide, you should be able to assemble the calibrator in short order.

PARTS LIST — ETI-170 CRO CALIBRATOR

Resistors.....all 1/4W, 2% unless noted

R1, R2, R38.....	1k
R3.....	10M
R4.....	33k
R5, 7, 10, 11, 12,	
41.....	1M
R6.....	1M8
R8.....	5k6
R9.....	2k7
R13, R40.....	47R
R14.....	10k
R15, R37.....	470R
R16, 17, 28, 29.....	330R 1%
R18, 19, 20, 30, 31,	
32.....	220R 1%
R21, 22, 33, 34.....	33R 1%
R23, 24, 25, 35,	
36.....	22R 1%
R26.....	12R 1%
R27.....	150R 1%
R37.....	470R
R39.....	390R
R42, R43.....	100R

Capacitors

C1.....	47μ/16VW RB electro.
C2.....	100n/100V met. poly.
C3, 5, 7,	
19-27, 29.....	10n ceramic monolithic
C4.....	100μ/25VW RB electro.
C6.....	47p ceramic
C8.....	15p NPO ceramic
C9.....	10p NPO ceramic
C10.....	2n2 ceramic monolithic
C11.....	22n ceramic monolithic
C12.....	220n met. poly.
C13.....	2μ/35VW solid tant.
C14.....	22μ/6VW solid tant.
C15.....	220μ/16VW electro.
C16.....	100p ceramic
C17, C18.....	22p NPO ceramic
C28.....	4μ/7/35VW solid tant.

Semiconductors

D1.....	1N914 diode or similar
LED1.....	5 mm red LED with bezel
IC1, 3, 4.....	4001 CMOS quad NOR
IC2.....	LM305 376 regulator
IC5, 6, 7, 8, 9, 10.....	4017 CMOS decade divider
IC11.....	4049 CMOS hex inverter
IC12.....	7402 TTL quad NOR
Q1, Q2.....	BC559 or similar

Miscellaneous

SW1.....	DPDT sub-min. toggle
SW2.....	2-pole 8-pos. rotary
SW3.....	1-pole 12-pos. rotary
PB1.....	Mom. contact sub-min. pushbutton
SK1.....	3.5 mm sub-min jack socket with sw.
SK2, SK3.....	Panel-type BNC socket
J1, J2.....	Tip jacks
X1.....	1 MHz crystal, par. res. with 30p
X2.....	10 MHz crystal, par. res. with 30p

ETI-270 pc board and Scotchcal label; 196 x 112 x 60 mm zippy box; 2 small knobs; 216-type 9 V battery; battery clip lead; 2 x 45 mm tapped spacers for pcb mounting; hookup wire, nuts, bolts, etc.

Estimated price: \$60

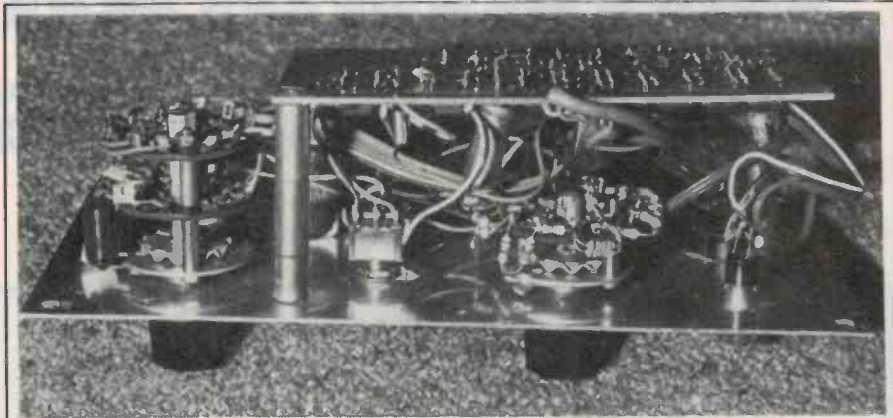

Mounting the pc board to the panel. The leads should be as short as possible to avoid coupling between circuit sections and to prevent unwanted radiation.

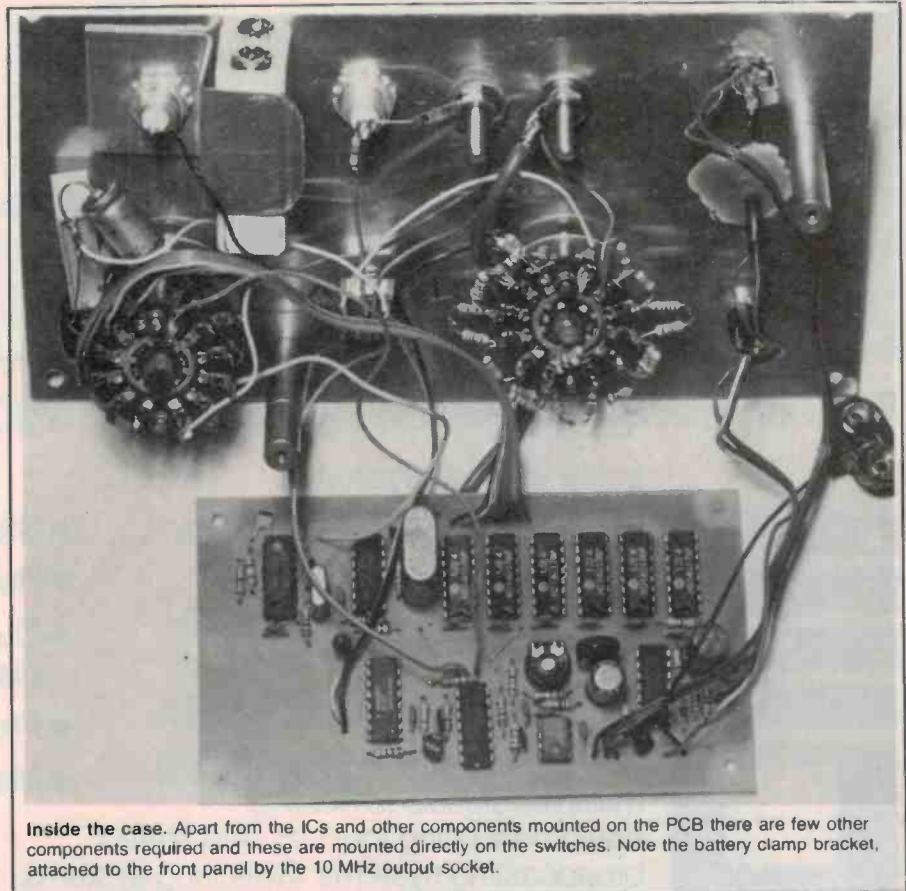

Inside the case. Apart from the ICs and other components mounted on the PCB there are few other components required and these are mounted directly on the switches. Note the battery clamp bracket, attached to the front panel by the 10 MHz output socket.

requires a known accurate reference. We used a 3½-digit multimeter, which is adequate. It should be attached to the regulated supply rail, and RVI adjusted to give the specified 5.05 volts. This gives 1% accuracy to the unit. As most CROs are good only to 2% or so, this is reasonable.

Further accuracy can be obtained if required by using the following alignment procedure. Switch the circuit to volts. Attach a 4½-digit meter to the volts output.

Short IC3 pin 10 to rail momentarily, and set RVI for 5 volts on the 5 V range. This gives accuracy limited only by the attenuator chain resistor tolerance.

Artwork: Front panel artwork and drilling diagram are available on request to ETI, PO Box 227, Waterloo, NSW 2017.



National

AM Stereo Signal Generator VP-8253A

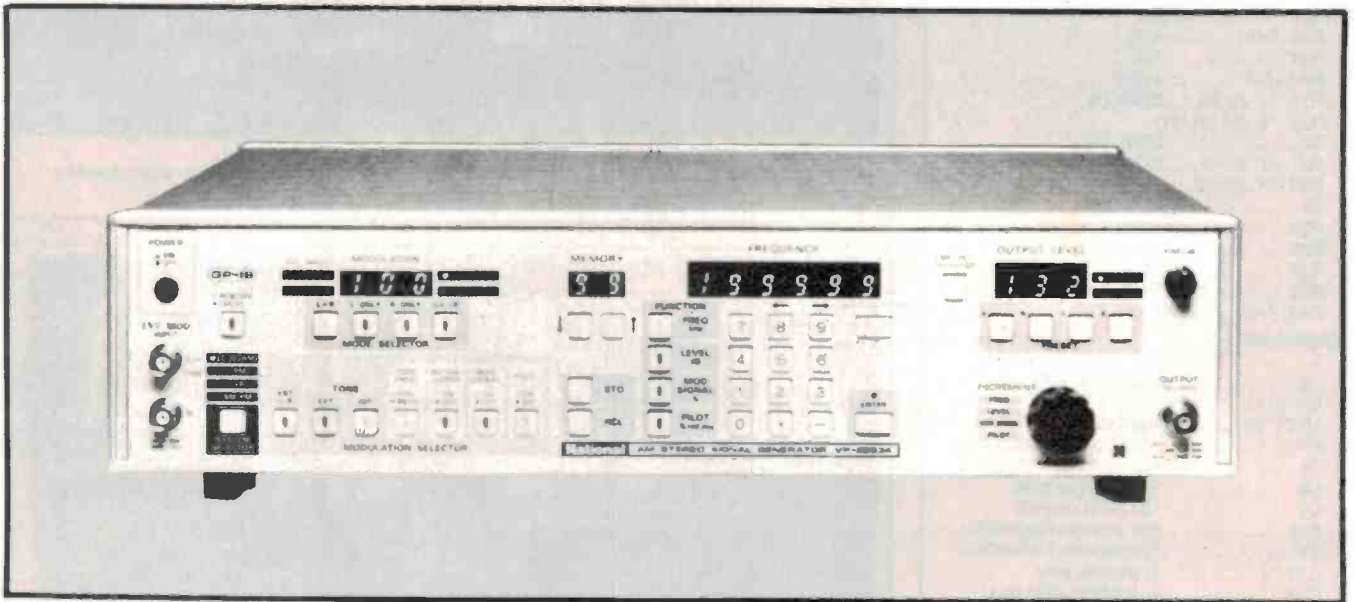

FCC-approved AM stereo systems

200 kHz to 1999.99 kHz

• AM Stereo Systems

C-QUAM

Four built-in AM stereo systems:

CPM

Motorola systems (C-QUAM)

ISB

Harris system (CPM)

AM-PM

Kahn/Hazeltine system (ISB)

Magnavox system (AM-PM)



This unit is capable of generating multiplex signals for testing equipment using four U.S. AM stereo broadcasting systems. Switching systems are as easy as pushing the SYSTEM SELECTOR push button.

• Stereo Modulation

• Remote Control Functions

• Output -133 to 19dBm, dB/dBm display selection

• Frequency Range

• Memory Function



SCIENTIFIC DEVICES AUSTRALIA PTY LTD

2 JACKS ROAD, SOUTH OAKLEIGH,
VICTORIA, 3167. PHONE: 579 3622
31 HALSEY ROAD, ELIZABETH EAST, S.A. 5112. PHONE: 255 6575
559A WILLOUGHBY RD, WILLOUGHBY 2068. PHONE: 95 2064

A technique called constrained or channel coding, explored for some time at IBM Research, makes possible faster, more error-free transmission and recording of digital data.

KEEPING THE MESSAGE CLEAR

T. Murphy

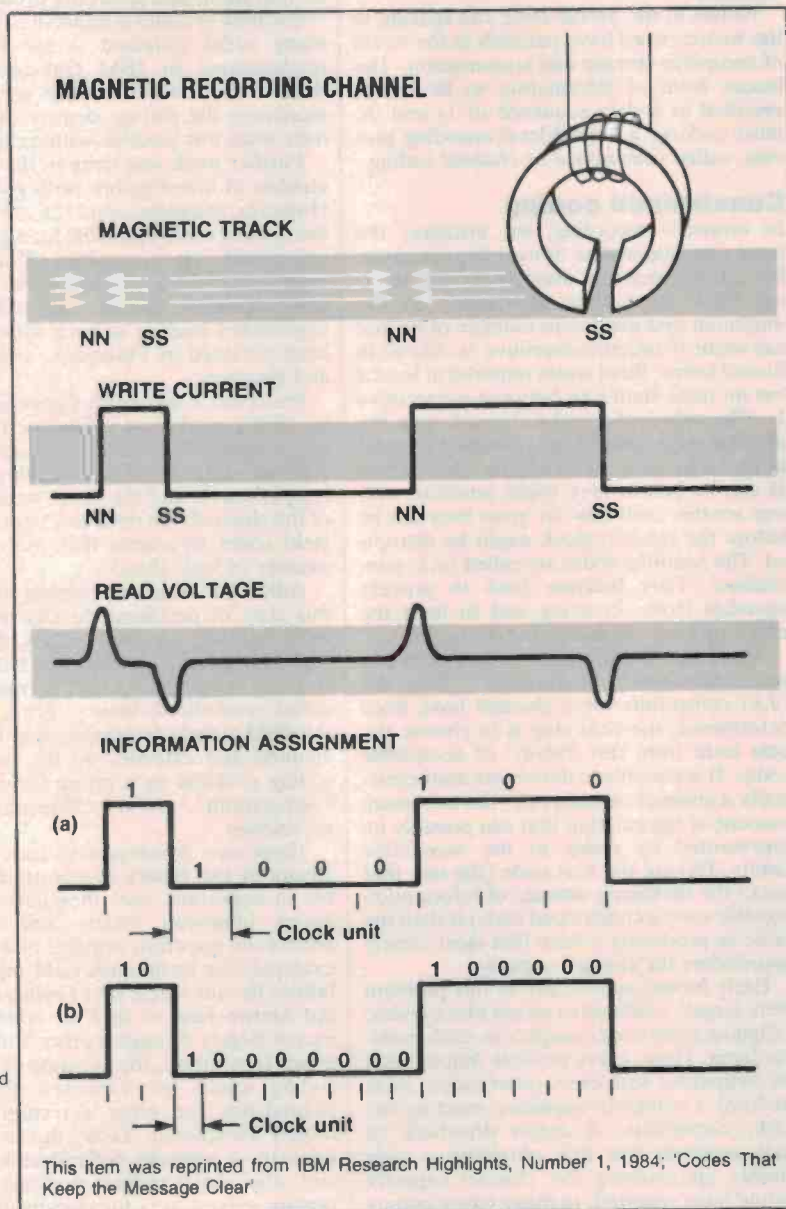

Figure 1. The two assignments at right show examples of encoded information: (a) is encoded under [0,3] constraints while (b) is [1,7].

This item was reprinted from IBM Research Highlights, Number 1, 1984; 'Codes That Keep the Message Clear'

STORIES IN THE popular press covering advances in computer technology often report on the contributions of physicists, engineers, and computer scientists. But the efforts of mathematicians and information theorists often remain hidden behind a jumble of blackboard scratchings and talk of 'sets', 'sequences', and 'mappings' that defy the comprehension of the outsider.

A case in point is *channel or constrained coding*. The increased capacities of today's high-end disk and tape storage systems have, in part, been made possible by the advances of researchers in this area of applied mathematics. Peter Franaszek, Roy Adler, and Martin Hassner are among those, at IBM Research and elsewhere, who have examined the problems of constrained coding theoretically, and have evolved algorithms (which can be computerized) for the design of optimized solutions and of actual hardware for coding and decoding.

"IBM is really the place where this was done," says Franaszek, who was responsible for some of the earliest work in the theoretical treatment of the constrained coding problem. "Previous approaches to this problem have been largely replaced in the industry by techniques often developed within IBM."

But at first glance it may not be obvious why there would be any particular problem with putting digital information onto a medium, or 'channel', such as magnetic tape or disk. The best way to store computer data might seem the straightforward method of taking the sequence of 1s and 0s and representing them directly. Following such a theory, a sequence such as 100110100110 might best be represented in the storage channel by a series of magnetizations of opposite polarity that correspond directly — one-to-one — with the elements of the sequence.

This approach, however, presents a number of practical difficulties in a real storage system. For example, intersymbol interference, i.e. the interference of adjacent 1s and 0s. This interference can occur because a channel is a physical system, and no physical system responds instantaneously and with

Dick Smith Electronics

Product Safety Check

POCKET MULTIMETER Q.1010

As part of Dick Smith Electronics continuing drive to maintain the quality of the product, a potential problem has been identified with a small number of one batch of the Dick Smith Pocket Multimeter, Catalogue number Q.1010.

Any customer who has purchased one of these multimeters since 1 JULY 1984 is advised to take it to the nearest Dick Smith Electronics store so that it can be checked free of charge.

Mail order customers should return their units to the address below preferably by certified mail. It is recommended that the unit not be used until this check has been carried out.

P.O. Box 321, North Ryde, N.S.W. 2113.



A897

If you own a
four-wheel drive,
are contemplating
buying one,
or are just
interested in this
exciting area . . .

get into your
newsagent now —
and get into
gear with

overlander
overlander
overlander

TECHNIQUES

perfect sharpness. There is always a degree of uncertainty. In the data sequence above, this could result in '11' being read as '1' — resulting in the wrong number being recorded. In transmission channels there is an analogous problem called 'spectral shaping'. And, in both storage and transmission, the internal 'clock' of the system can also be disrupted by the input of arbitrary streams of data.

These kinds of problems are not particular to computers, or even to the 20th century. Messages sent in Morse code could not be understood if they were transmitted as continuous strings of *dits* and *dahs* with no pauses. No one could read a book or business letter or a newspaper if the words had no spaces between them. The information would be there in each case, but it would be unusable.

Pauses in the Morse code and spacing in the written word have parallels in the world of computer storage and transmission. The binary form of information to be saved, encoded as a data sequence of 1s and 0s, must undergo a second-level encoding process, called *constrained* or *channel* coding.

Constrained coding

In magnetic recording, for instance, the most common means of avoiding intersymbol interference and maintaining the internal clock is to place restrictions on the minimum and maximum number of 0s that can occur between consecutive 1s. Stated in formal terms, these codes required at least d but no more than k 0s between consecutive 1s. The values of d and k depend upon the physical properties of the particular channel in question; that is, how close consecutive 1s can be before they might interfere with one another, and how far apart they can be before the internal clock might be disrupted. The resulting codes are called (d,k) *constrained*. They function both to prevent mistakes from occurring and to limit the effect of those mistakes that do occur.

There may be many codes that meet any particular set of (d,k) constraints. Once the (d,k) constraints for a channel have been determined, the next step is to choose the best code from this 'family' of acceptable codes. It is possible to determine mathematically a channel capacity; i.e. the maximum amount of information that can possibly be represented by codes in the acceptable family. Picking the best code (the one that packs the maximum amount of information possible onto a constrained code) is then the same as producing a code that most closely approaches the channel capacity.

Early formal approaches to this problem were largely confined to *mixed block* codes: assigning fixed coder outputs to each possible input. Here, every possible output must be compatible with every other output so as to form a complete sequence meeting the (d,k) constraints. A major drawback of such methods was that obtaining a code closely approaching the channel capacity would have required, in many cases, coders

of impractical complexity. A consequence of this was that the recording or transmission system often operated well below its potential.

Solving the problem

Perhaps the earliest systematic methods for overcoming this problem were Franaszek's results during the 1960s that avoided the use of fixed blocks and made use of the notion of codes based on *finite state descriptions*. Finite state descriptions are produced by abstract mathematical structures known as *finite state machines*. These descriptions enable each segment of information to be coded while taking into account how both the incoming bit stream and neighbouring segments of information were coded. The resulting codes allowed efficient computer optimization, and generally produced large reductions in coder complexity. One of the many codes obtained is the (2,7) code implemented in IBM high-capacity disk drives. This code has been credited with increasing the storage density substantially over what was possible with earlier codes.

Further work was done in this area by a number of investigators, with good results. However, instances could still arise in which the densest coding possible for a given channel would require coders of unbounded complexity. This suggested the need for more general forms of codes. Two approaches leading to such solutions have been obtained by Franaszek, and by Adler and Hassner.

Franaszek's method is a generalisation of his earlier work, and is likewise based on a knowledge of the information stream to be encoded (usually called *look-ahead* in coding parlance), and the finite state structure of the channel. He obtained algorithms that yield coder structures that use a minimal amount of look-ahead.

Adler and Hassner provided solutions to this class of problems through a different mathematical approach. They discovered and developed a relationship between constrained coding and a field of mathematics called *symbolic dynamics*. Their results in this field include techniques that have been adapted and extended to the constrained coding problem by a group including Don Coppersmith, John Moussouris and themselves.

These new developments have not only advanced the theory of constrained codes but in important cases they have also produced improved coders and decoders. Numerous questions remain, however. For example, the techniques yield many possibilities for any single set of constraints. It is not known how to find an optimal code, except largely through a process of trial and error. In addition, the question of how such coding could be extended to include redundancy for error detection remains largely unexplored. Today this is generally done by a separate coder/decoder. These and other issues suggest that this field will remain a lively area for investigation. ●

A 'speech-tailored' COMMUNICATIONS SPEAKER

Robert Irwin
Roger Harrison
VK2ZTB

IN ANY COMMUNICATIONS SYSTEM where speech is used, 'intelligibility' is enhanced by restricting the frequency response, over and above simple channel bandwidth considerations. Restricting the voice frequency spectrum to a range from about 100 Hz to about 3 kHz removes many of the characteristic components generated during speech but does not reduce intelligibility. Telecom employs a frequency range of 300 Hz to 3 kHz in the telephone system, for example.

In amateur radio, the emphasis is on speech intelligibility. Any unnecessary speech spectrum components present will generally only degrade the useful information. For this reason, most transmitting equipment these days incorporates speech response filtering in the audio system.

But this is not always the case with the receiver. The audio amp may have a little bottom-end rolloff and some simple highcut response tailoring. Problem is, the signal coming out of the detector will contain components spanning right across the audio spectrum. When receiving speech, low audio frequency noise will 'muddy' the signal, reducing intelligibility, making it hard to 'copy'. Likewise, higher audio frequency noise (spits and crackles) can make the signal difficult to copy as the ear is quite sensitive to this.

The internal speakers in communications receivers and transceivers generally have what can best be described as an 'indifferent' response. Many have a 'peaky' response at the higher audio frequencies, about 4 to 10 kHz, and equipment cabinets make the bottom end response 'lumpy'.

A nondescript speaker in any sort of box,



After all the care taken with the design and performance of modern communications receivers and transceivers, they're virtually all let down right at the end of the chain — the loudspeaker. Speech 'intelligence' can be marred by various deficiencies in the audio amp and speaker response, making the signal sound 'muddy' or just 'hard to copy', despite good signal strength. With this speaker it's 'Q5 all the way'.

or just on a baffle, can remarkably improve the sound from a receiver or transceiver — apart from throwing the sound in the right direction (i.e. at you!). But, by 'tailoring' the response to remove the unwanted audio spectrum components coming out of the receiver, the result can be dramatic indeed.

This project employs a number of little 'tricks' to obtain the appropriate tailored response for improved intelligibility. It involves choosing a driver that partly has a natural response approaching what we want and then using L and C filter elements to finish the job.

The ETI-742 Communications Speaker is designed to plug directly into the extension speaker outlet on a receiver. Its power handling capability, at 10 watts, is more than ample for the application and it should make not just a useful adjunct to any 'shack', but a decorative one as well.

The speaker

Because of the small frequency range that needs to be covered there are no exacting demands on the speaker to be considered. Rather than use a filter to tailor the bass end of the range, a speaker which naturally rolled off the bottom end could be used. The only demand on the top-end performance of the speaker is that it extends beyond 3 kHz or so. The speaker we selected was a Pioneer 4 ohm, 6" (150 mm) car speaker sold by Jaycar (type H16CP60-02C). These speakers have a free-air resonance of around 150 Hz, are rated to handle 10 W RMS and have the advantage of being very cheap.

After running a frequency response we found that this speaker had one other unex-

COIL WINDING DETAILS

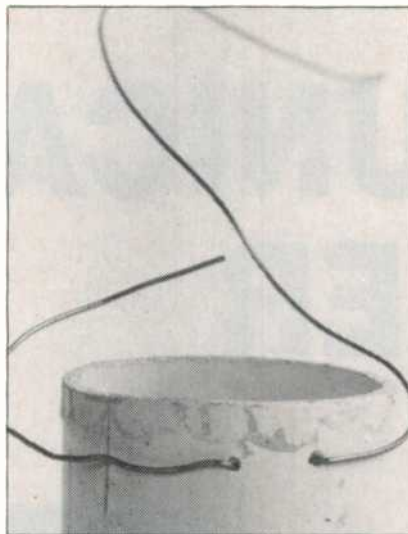

The coil on the prototype was wound on a piece of 50 mm internal diameter, PVC pipe which can be obtained from most hardware or plumbing supply stores. Cut off a 90 mm length of the pipe and drill a pair of 1.2 mm holes about 5 mm from edge on both ends of the pipe. These holes will be to secure the coil wire. The coil was wound from 18 B&S, 20 swg enamelled copper wire. Start by threading the wire in one hole and out the other on one end of the pipe. Leave about 100 mm protruding as a connection lead. Wind a layer of about 60 turns on to the pipe making sure that the turns are close wound and neat. When you have completed the first layer you can secure the turns with a bit of sticky tape and wind another layer back the other way on top of the first. Repeat this once again so that you end up with a coil of three, 60 turn layers (180 turns in all). The end of the coil should be at the opposite end to which you started. The wire can be secured by threading it through the two holes at this end once again leaving about 100 mm as a connection lead. Note that before soldering the leads of the coil to anything you will have to scrape the enamel off the ends.

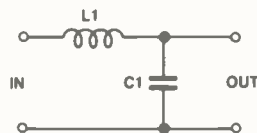

Figure 1. Low pass LC filter.

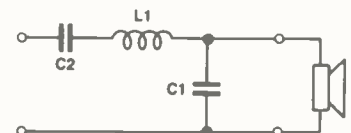

Figure 2. Speech filter network.

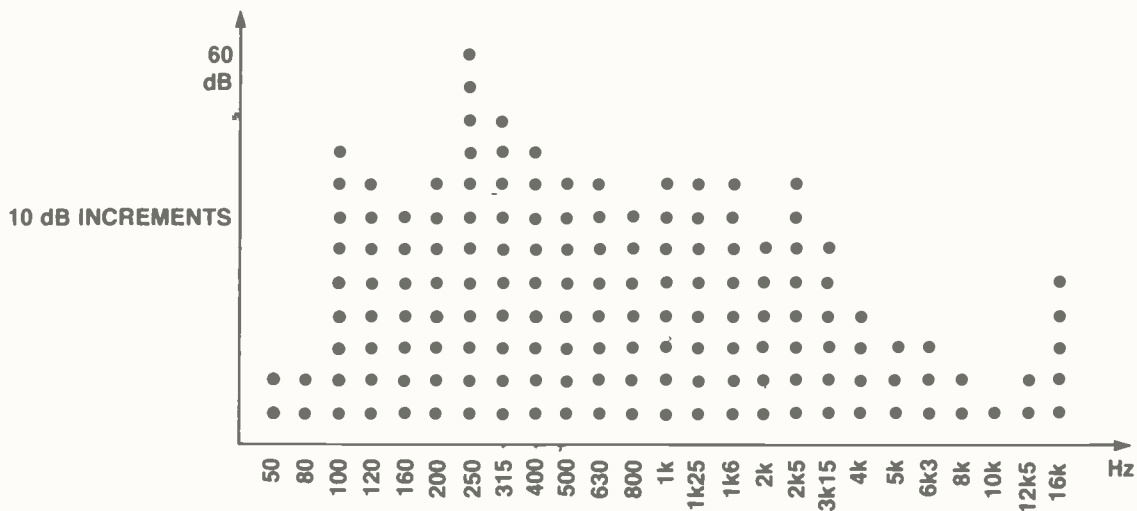

Figure 3. Typical frequency response of the male voice saying "Aaaahhhh". The response was measured on an Ivis IE-30A Spectrum Analyser.

pected advantage. There was a dip in the response around the 300 Hz region. You may think that unevenness in the response would be the last thing to praise in a speaker, but in this case it is very useful indeed as the region around 200 to 300 Hz often makes speech sound 'muddy' through an amplification system.

Often, in speech reinforcement systems, a parallel resonant circuit in series with the driver is used to artificially create a dip in the response in this region.

Although the driver is a 4 ohm type, the majority of modern (and not-so-modern) receiver audio amps will drive this impedance without complaining (but check to be sure).

Tailoring the response

The first step in adjusting the frequency re-

sponse is to roll off the top end of the speaker. Figure 1 shows the circuit of an LC low pass filter network. I happened to have a 1 mH coil lying around from a previous crossover design so I conveniently let L1 be 1 mH (see 'Coil Winding Details'). The corner frequency of the low pass network is given by:

$$2\pi f = 1/\sqrt{LC}$$

If we let the rolloff frequency be 2 kHz, then the value of C is 6.8 μ F. It was found that, due to slight peakiness in the driver's response around 2 kHz, it was better to start rolling off a bit earlier so a value for C1 of 10 μ F was used.

The frequency response was reviewed again and it was found that the top-end response rolled off quite nicely, so now for the



Figure 4. Wiring up the filter and speaker.

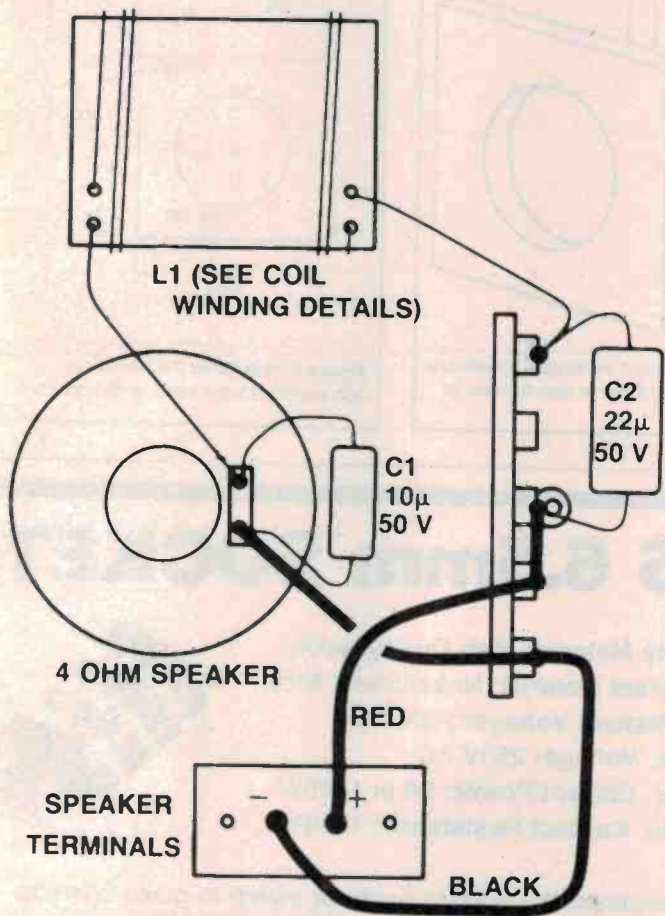

PARTS LIST — ETI-742

Speaker	
SP1	150 mm 4 ohm car speaker
Capacitors	
C1	10 μ F 50 V bipolar electrolytic
C2	22 μ F 50 V bipolar electrolytic
Inductors	
L1	1 mH air core inductor (see coil winding details)

Miscellaneous
2-way spring terminal block; 5-way tag strip; 300 x 0.2 mm hookup wire; 300 x 900 x 13 mm particleboard; 800 x 13 x 13 mm beading; wood glue; screws; nails; non-hardening sealant.

Price estimate: \$10-\$12

Project 742

bottom end. The speaker resonance gave quite a peak at 200 Hz so a series capacitor was called for. This cuts back the peak at 200 Hz and also rolls the bottom end off at a steeper rate. Because the two poles of the combined network interact with one another to some extent, a certain amount of experimentation was required to find a value for this capacitor that would bring the peak down to a suitable level. It was found that a value of about 22 μ F gave the appropriate response (see Figure 2).

Construction

The speaker and filter were mounted in a 225 x 225 x 150 mm chipboard enclosure.

There is no particular problem with the construction of this box as all the joints are butt joints (about as far as my woodworking abilities go) and there are no nasty ports or braces to confuse the would-be woodworker.

The enclosure itself is not all that critical, as long as it is roughly the same size. The prototype was made from 13 mm thick chipboard. You will need a piece about 300 x 900 mm. If you have some off-cuts that will be suitable then use them, otherwise Figure 6 shows how to cut the box from a 300 x 900 mm sheet which is a standard size sold in hardware stores.

Once you have cut all the pieces, sandpa-

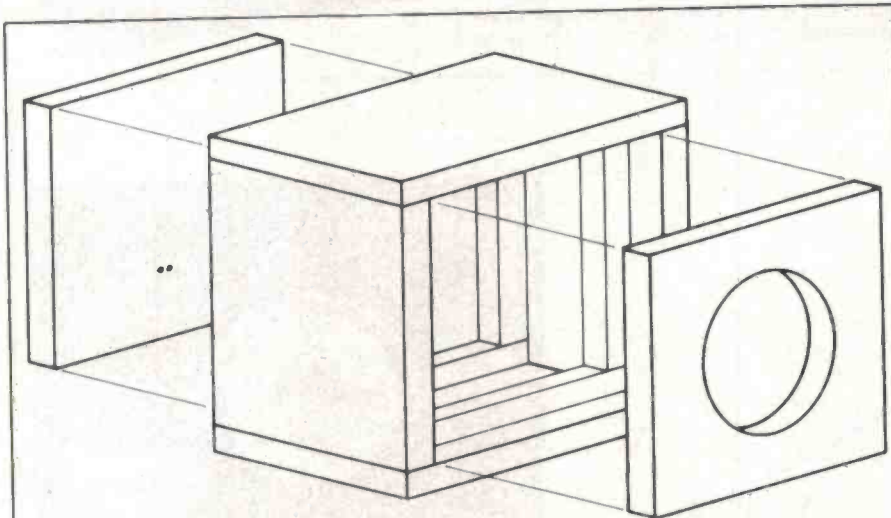

Figure 5. How the box fits together. Note that the sides butt against the top and the bottom. Cleats are used to mount the front and back panels on. NB: The rear cleats are set in 13 mm in from the rear of the box. The face board is set in 5 mm in front of the box.

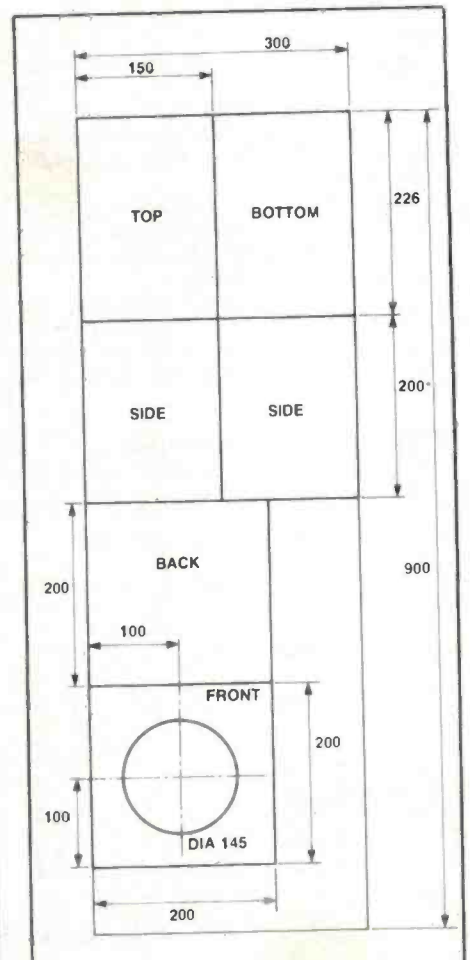
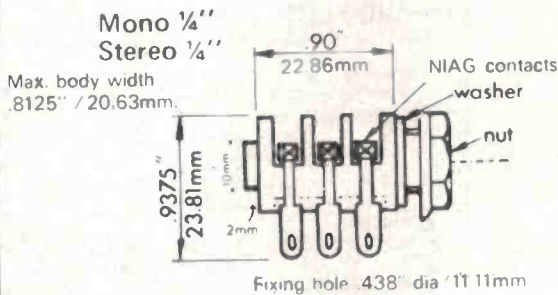
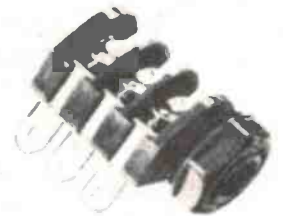

Figure 6. How to cut the box from a 900 x 300 x 13 mm sheet of chipboard.

CLIFF S2 SERIES 6.5mm SOCKETS



- Body Material: High Quality Nylon.
- Contact Material: Nickel Silver Alloy.
- Withstand Voltage: 2000V DC
- Max. Voltage: 250V AC
- Max. Current/Power: 5A or 1000W
- Nom. Contact Resistance: 15m Ω .



Available with switch to break or switch to make contacts in mono and stereo versions. *Wide range of colours.*

DELSOUND PTY. LTD. 1 Wickham Terrace (cnr. Wharf St.), Brisbane.
 Australian Distributor for Cliff. Ph: (07) 229-6155. Telex: AA44442.

per down all the rough edges. Care should be taken when cutting the hole for the speaker in the front baffle. Be sure that you do not make it too big otherwise there may not be enough 'meat' left around the edges to screw the speaker on to.

Assemble the top, bottom, sides and front baffle together. All the joints should be glued and then screwed or nailed together (if you are using screws then drill small pilot holes first to ensure that the chipboard doesn't split).

The front baffle should be mounted about 5 mm back from the front edge so that a grille can be mounted if desired. To ensure that the back of the box will sit properly, cleats made from 13 mm square beading should be nailed 13 mm in from the back edge.

To complete the woodwork, two holes should be drilled in the bottom of the back panel for the speaker terminals.

The box can now be finished off in any way you please. The prototype was finished with an iron-on wood laminate that can be bought from most hardware stores. The laminate is cut to size with a pair of scissors and placed in position. A hot iron (clothes iron not soldering iron! Ask your mother how it works if you've never used one!) is then run over the top of the laminate thus melting the glue on the underside and bonding the laminate to the surface. The front baffle was painted matte black.

Once the box is finished you can mount the speaker to the front baffle. Use some silastic sealant around the edge of the speaker to form an air-tight seal. The coil was mounted next. It is positioned on the floor of the box and to one side. I secured it with Araldite. A small piece of tagstrip was screwed to the floor also. The components can now be wired up according to the wiring diagram. Note that C1 is wired directly across the speaker terminals. Finally, wire up and mount the speaker spring terminals on the back panel. Before closing up the back, some acoustic stuffing should be placed inside the box to cut down on box resonances. The back can now be screwed on.

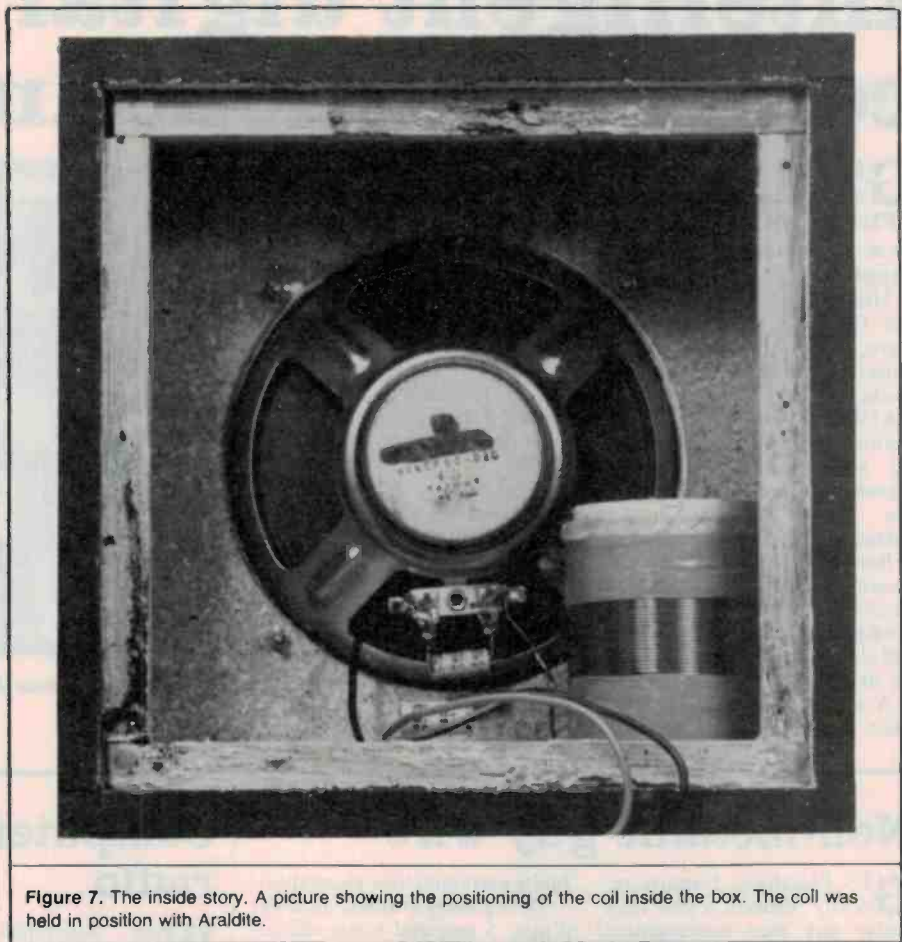

Figure 7. The inside story. A picture showing the positioning of the coil inside the box. The coil was held in position with Araldite.

Listening

All that's left to do now is to hook the speaker up to your receiver and find someone to listen to. If your receiver doesn't have an extension speaker outlet then you can disconnect the internal speaker and connect up a socket here. We tested the speaker out on an Icom IC-R71A communications receiver and found that it gave better clarity than the internal speaker, apart

from the advantage of throwing the sound forward.

"Cuts out all the crud on the bottom end," was the knowledgeable opinion of our humble editor. He was right. I could actually hear what was being said on 3565 kHz without all that rumble and mud. (Judging by the conversation it may have been better if all the crud had been left in!). Happy listening!

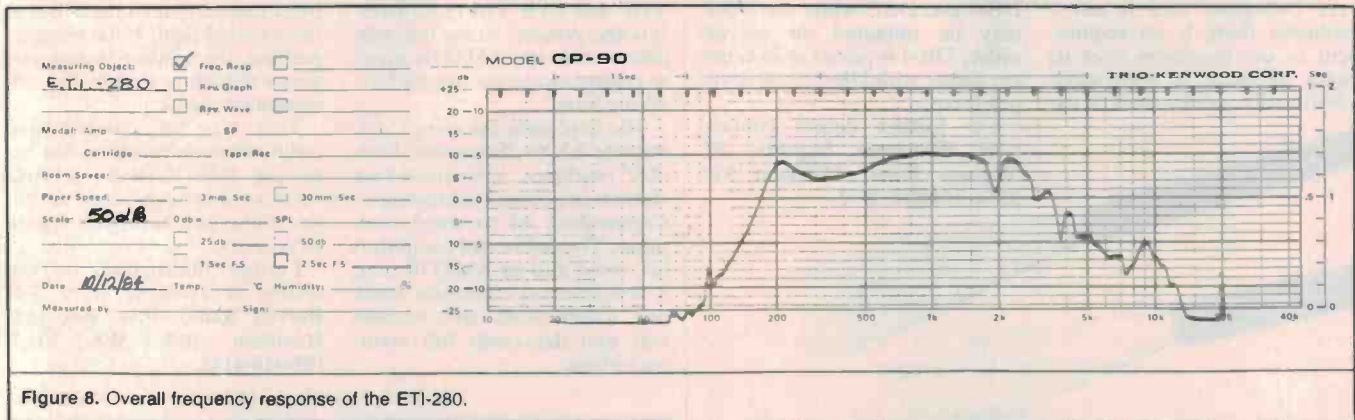

Figure 8. Overall frequency response of the ETI-280.

Intelligent digital communications interface

GFS Electronic Imports has undertaken the manufacture of a new digital communications interface unit, the model CPU-100. It's designed for interfacing a dumb ASCII terminal to a radio transceiver via a modem, which GFS can also supply.

Using a 6809 microprocessor, the CPU-100, via ROM software, is able to perform a wide variety of functions. These include transmission of both BAUDOT and ASCII at user definable speeds, as well as digital selective calling. SITOR transmission may also be possible given the appropriate software.

Because of its built in intelligence the CPU-100 is extremely flexible. For example it may be configured for either simplex or full duplex operation depending on its end user's requirements.

A wide variety of applications exist. These include accessing a

mainframe computer from a vehicle or aircraft and radio teletype operation where a number of stations operate on the one frequency, and the calling station wishes to address each one separately via selcal.

GFS is able to supply the CPU-100 as a pre-wired and tested printed circuit board, or as a fully housed unit including its MDK-17 modem. Special applications software can also be made available.

For further details contact the manufacturer, **GFS Electronic Imports, 17 McKeon Rd, Mitcham, Vic 3132. (03)873-3777.**

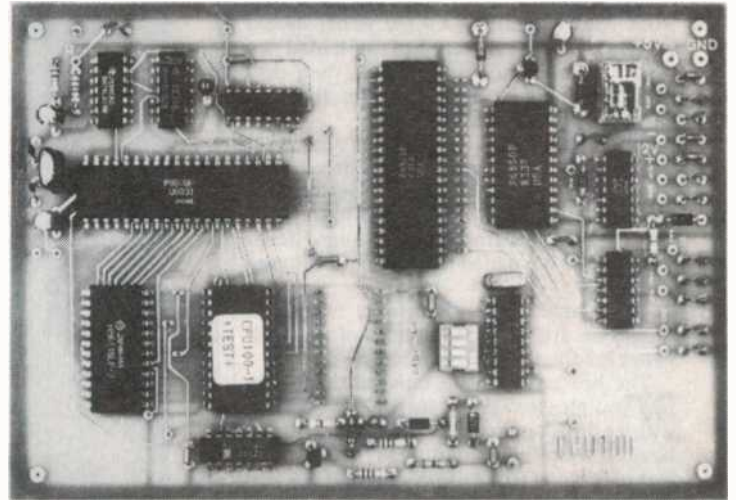

The CPU-100 interface unit. It interfaces a mainframe to a radio transceiver.

Non-metallic guy wire

GFS Electronic Imports recently released a new alternative guy wire manufactured using continuous yarn fibreglass filament and vinyl chloride sheath.

Known as Debeglass Wire, GFS claims it offers its users a number of advantages over using steel as a guy wire, such as, a higher tensile strength than steel wire of the same diameter, no corrosion, as well as lighter weight than an equivalent diameter of steel wire.

As Debeglass wire is not a conductor there is no requirement to use insulators over its length as there is with steel. Additionally, unlike steel, it ex-

hibits extremely low elongation.

Debeglass is available in sizes, 4 mm, 5 mm and 6 mm diameter. The tensile strength of DB-4 is 430 kg, DB-5 is 560 kg while DB-6 is 970 kg.

Applications exist for Debeglass wire in many areas from the guying of radio masts to the supporting of HF antenna arrays. It is also uniquely suited to use in marine and other highly corrosive environments.

GFS Electronic Imports advises that it keeps stocks of the DB-4 and DB-5 while the DB-6 may be obtained on special order. DB-4 is priced at 48 cents per metre with DB-5 at 68 cents per metre.

For further details contact **GFS Electronic Imports, 17 McKeon Road, Mitcham Vic 3132. (03)873-3777.**



Computer talk by 2-way radio

West Australian mining companies are using portable computers to improve two-way radio communications.

Radio communications firm T R Barrett of Spearwood, South of Perth, has helped the companies set up communications networks using its commercial two-way radios with Commodore computers.

Transmission can be via HF (3 to 30 MHz) single sideband or VHF and UHF FM radio links. It is also possible to use the computers and its AMTOR units to communicate via regular telephone lines.

The field units are using Commodore SX 64 'Executive Portable' machines, while most base stations are connected through a Commodore 64 personal computer. The radios and computers are wired into an AMTOR unit, a sophisticated electronic black box which sends and receives text and data with full error-correction.

The AMTOR unit (which is normally used for advanced Amateur Radio communications) continuously checks each character as it is received, and transmits signals back every split second so that the sending station's computer knows the message has been received properly.

Each sequence takes only 450 milliseconds: 250 ms is used to transmit, 70 ms for verification, and the rest in sending the signal from one station to the other at the speed of light. If the text gets garbled, the sending station just keeps repeating it until the two computers agree.

This type of computerised radio communication is fast replacing radio teletype services because of its speed and reliability. It also offers a higher degree of security.

Further information on the system is available from **T R Barrett Radio, P.O. Box 198, Hamilton Hill, WA 6163. (09)418-4141.**

New mm wave detector series

Four new millimetre frequency detectors, offering excellent tangential sensitivity for use in many applications, have just been announced by Alpha Industries.

The frequency range 18 GHz to 220 GHz is covered in nine bands. For example the fixed tuned units have -55 dBm sensitivity at 35 GHz and biased type detectors have -68 dBm sensitivity at 35 GHz.

For applications in test sets and integrated subsystems the 971/925 series of self-biased detectors operate over the full waveguide band without tuning. At 50 GHz and above, beam lead GaAs Schottky barrier diodes are used.

Series 973 detectors provide flat, self-biased response with VSWR ranging from 1.6:1 to 2:1, over full waveguide bands up to 60 GHz. The detector output is typically 200 mv/mw at 35 GHz.

The 965D series of detectors has the highest tangential sensitivity, ranging from -48 dBm to -68 dBm depending on frequency. These detectors feature a field replaceable wafer with a GaAs Schottky barrier diode. Provided as part of this detector assembly is a battery bias supply.

For information contact **Benmar International, P.O. Box 4048, Sydney NSW 2011. (02)233-7939.**



Tara Patch. A connection system for telephone and radio.

Phone-radio interface

After three years of planning and development Australia's only phone-patch unit specifically designed for radio amateurs and CB operators is now available.

Marketing manager of Tara Systems, Neil Parkinson said it was the latest model in a range of Tara radio/telephone interconnection units in use throughout Australia by emergency services, government agencies, and business enterprises.

"It's not only a phone-patch but can be used as an interface between up to three different base radio sets. This enables the user to engage in cross-band operations at the flick of a switch, or provides an easy way

to record all communications by plugging in a cheap cassette recorder."

The basic unit will do everything normally expected of a phone-patch for radio amateurs and CB operators but it can be adapted to suit individual special requirements.

The only external adjustment, a slider volume control, adjusts output from the monitor speaker.

All radio signal levels are internally preset but can be adjusted to suit individual needs.

For further information contact Tara Systems, 6 Malvern St, Bayswater Vic 3153. (03)729-0118.

Tell them you read it in ETI

WHAT?

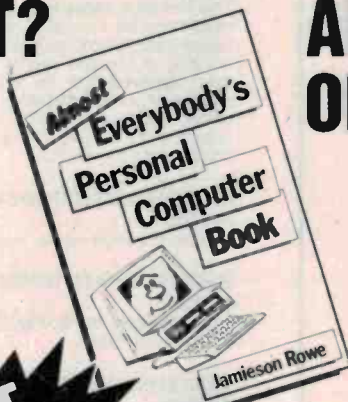

ANOTHER BOOK ON PERSONAL COMPUTERS?

- * Behind the myths and jargon
- * Data processing made simple
- * Software and hardware explained
- * How to care for and keep your personal computer

You won't need a degree in mathematics or any previous knowledge on electronics or computers to understand **ALMOST EVERYBODY'S PERSONAL COMPUTER BOOK**. It will not make you an instant expert on every aspect of personal computers, but it will give you a good basic understanding of what they're all about.

JUST \$8.95
POSTAGE INCLUDED

Please send me copies of "ALMOST EVERYBODY'S PERSONAL COMPUTER BOOK" for just \$8.95

Name..... Address

Postcode..... Phone.....

Cheque*/Money Order* enclosed for \$8.95, or bill my Bankcard American Express Card Mastercard

Card No.

Card expiry date.....

Signature.....

(UNSIGNED ORDERS CANNOT BE ACCEPTED)

Detach this coupon and mail it in an envelope to: FREEPOST No. 4, THE FEDERAL PUBLISHING CO. P/L, P.O. Box 227, WATERLOO 2017. (No postage stamp required if posted in Australia.) *Make cheques /money orders payable to THE FEDERAL PUBLISHING CO. P/L.

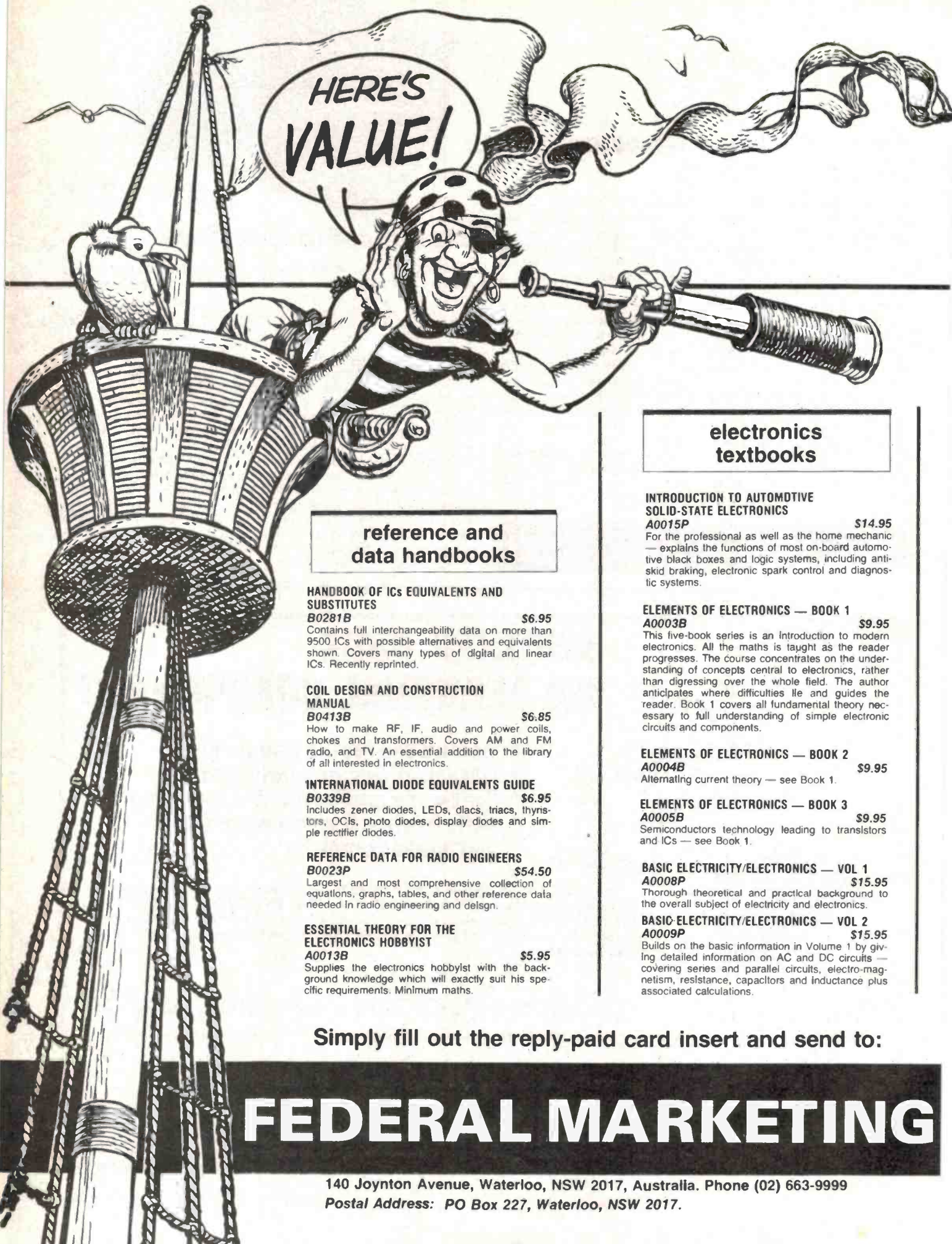

**HERE'S
VALUE!**

**reference and
data handbooks**

**HANDBOOK OF ICs EQUIVALENTS AND
SUBSTITUTES**

B0281B \$6.95
Contains full interchangeability data on more than 9500 ICs with possible alternatives and equivalents shown. Covers many types of digital and linear ICs. Recently reprinted.

**COIL DESIGN AND CONSTRUCTION
MANUAL**

B0413B \$6.85
How to make RF, IF, audio and power coils, chokes and transformers. Covers AM and FM radio, and TV. An essential addition to the library of all interested in electronics.

INTERNATIONAL DIODE EQUIVALENTS GUIDE

B0339B \$6.95
Includes zener diodes, LEDs, diacs, triacs, thyristors, OCIs, photo diodes, display diodes and simple rectifier diodes.

REFERENCE DATA FOR RADIO ENGINEERS

B0023P \$54.50
Largest and most comprehensive collection of equations, graphs, tables, and other reference data needed in radio engineering and design.

**ESSENTIAL THEORY FOR THE
ELECTRONICS HOBBYIST**

A0013B \$5.95
Supplies the electronics hobbyist with the background knowledge which will exactly suit his specific requirements. Minimum maths.

**electronics
textbooks**

**INTRODUCTION TO AUTOMOTIVE
SOLID-STATE ELECTRONICS**

A0015P \$14.95
For the professional as well as the home mechanic — explains the functions of most on-board automotive black boxes and logic systems, including anti-skid braking, electronic spark control and diagnostic systems.

ELEMENTS OF ELECTRONICS — BOOK 1

A0003B \$9.95
This five-book series is an introduction to modern electronics. All the maths is taught as the reader progresses. The course concentrates on the understanding of concepts central to electronics, rather than digressing over the whole field. The author anticipates where difficulties lie and guides the reader. Book 1 covers all fundamental theory necessary to full understanding of simple electronic circuits and components.

ELEMENTS OF ELECTRONICS — BOOK 2

A0004B \$9.95
Alternating current theory — see Book 1.

ELEMENTS OF ELECTRONICS — BOOK 3

A0005B \$9.95
Semiconductors technology leading to transistors and ICs — see Book 1.

BASIC ELECTRICITY/ELECTRONICS — VOL 1

A0008P \$15.95
Thorough theoretical and practical background to the overall subject of electricity and electronics.

BASIC ELECTRICITY/ELECTRONICS — VOL 2

A0009P \$15.95
Builds on the basic information in Volume 1 by giving detailed information on AC and DC circuits — covering series and parallel circuits, electro-magnetism, resistance, capacitors and inductance plus associated calculations.

Simply fill out the reply-paid card insert and send to:

FEDERAL MARKETING

140 Joynton Avenue, Waterloo, NSW 2017, Australia. Phone (02) 663-9999
Postal Address: PO Box 227, Waterloo, NSW 2017.

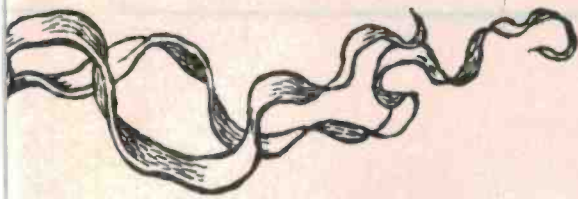

LOOK!

great book buys to suit everyone...

computer hardware and techniques

THE 6809 COMPANION

J0154B \$6.95
This is not a beginner's introduction to microprocessors in general but a discussion of the features of the 6809 and a reference.

EXPERIMENTS IN ARTIFICIAL INTELLIGENCE FOR SMALL COMPUTERS

J0168P \$14.25
Artificial Intelligence is the capability of a device to perform functions normally associated with human intelligence. With this book, a small computer with extended BASIC and some knowledge of BASIC language, you can conduct experiments in artificial intelligence.

PRACTICAL COMPUTER EXPERIMENTS

J0172B \$5.95
How to build typical computer circuits using discrete logic. Useful intro to devices such as adders and storers as well as a general source book of logic circuits.

USING THE OSBORNE 1 COMPUTER

J0327P \$21.50
How to get the most out of the Osborne 1 portable computer.

MICROSOFT BASIC

J0406A \$24.50
Presents a complete introduction and tutorial on programming in BASIC using Microsoft BASIC, Release 5.0. Covers branching and loops, strings, editing, arrays and files, and arithmetic in BASIC.

COMPUTERS AND COMPUTING — VOL 4

J0415E \$5.95
Projects and reviews covering hardware, memory expansion, popular home computers and software examples for beginners and experienced programmers.



Prices subject to change without notice.

constructional projects

ELECTRONICS PROJECTS FOR YOUNG SCIENTISTS

D0045E \$3.95
PH meter, geiger counter, helium-non laser, sound-level meter, solar cells, negative ion generator and more.

POWER-SUPPLY PROJECTS

D0047B \$5.95
Gives a number of power-supply designs, including simple unregulated types, fixed-voltage regulated type and variable voltage stabilised designs. The designs are all low-voltage types for semiconductor-circuits.

ELECTRONIC PROJECTS USING SOLAR CELLS

D0049B \$6.75
Includes a number of projects that benefit from solar power and obviate the problems encountered with batteries, such as weight and bulk, frequency of replacement, and failure when batteries are exhausted.

DIGITAL IC PROJECTS

D0050B \$6.75
The projects included in this book range from simple to more advanced projects — some board layouts and wiring diagrams included.

28 TESTED TRANSISTOR PROJECTS

D0053B \$4.50
Some circuits are new, others are familiar designs. Projects can be split and/or combined.

PROJECTS IN OPTO-ELECTRONICS

D0057B \$6.75
Included are simple circuits using ordinary LEDs as well as more sophisticated designs such as infra-red transmitters and detectors, modulated light transmission and also photographic projects, etc.

ELECTRONICS SECURITY DEVICES

D0059B \$6.95
Besides including both simple and more sophisticated burglar alarm circuits using light, infra-red and ultra-sonics, this book also gives circuits for gas and smoke detectors, flood alarms, fire alarms, doorphones, etc.

POPULAR ELECTRONIC CIRCUITS — BOOK 2

D0061B \$7.75
A wide range of designs for electronics enthusiasts who are capable of producing working projects from just a circuit diagram without the aid of detailed information.

AERIAL PROJECTS

D0064B \$6.75
Practical aerial designs including active, loop and ferrite which are relatively simple and inexpensive to build. The complex theory and mathematics are avoided.

ELECTRONIC PROJECTS FOR CARS AND BOATS

D0067B \$6.75
Fifteen fairly simple projects designed for use with 12V electrical systems but in some cases can also be employed with 6V and/or positive earth systems.

BUILD YOUR OWN ELECTRONIC EXPERIMENTER'S LABORATORY USING ICs

D0384B \$2.75
Projects include a simple audio frequency oscillator, a TTL pulse detector, a simple square wave generator and a high impedance voltmeter. Limited supplies.

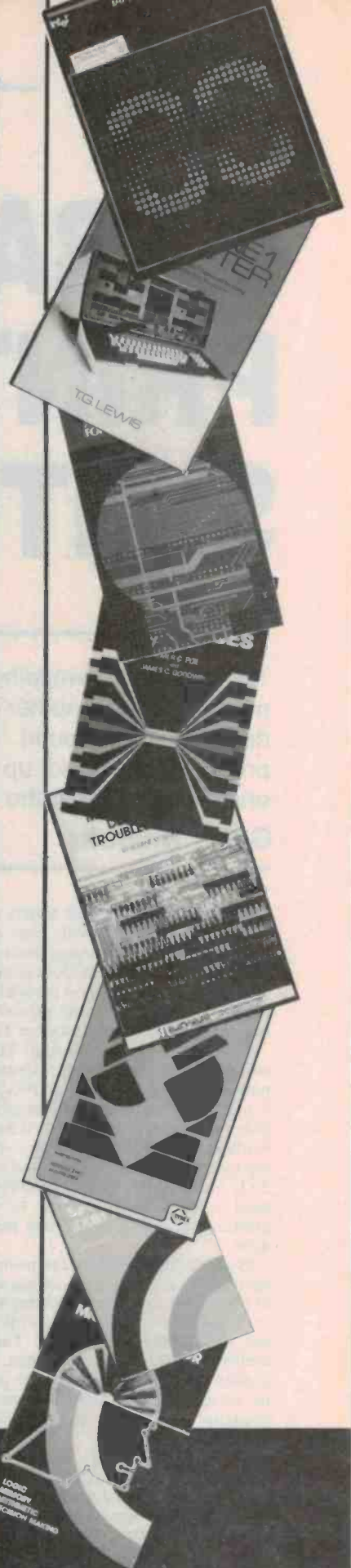

Book Sales

MORE GREAT BOOKS ON PAGE 118 ETI February 1985 — 91

PARALLEL PRINTER SWITCH

Tired of plug swapping whenever you want to change from one printer to another? This low-cost project should suit you down to the ground. It lets you have two Centronics-type printers connected up permanently, so that you can select one or the other at the flick of a switch.

Geoff Nicholls

IF YOU HAVE both dot matrix and daisy-wheel printers to go with your computer, you probably find changing from one to the other a hassle with a modern computer system. With both serial and parallel ports you might be able to run one printer on each, but what if you have a modem as well?

Fear not, I have a solution! This project switches the 12 most critical Centronics signals from one printer port to two printers. It is really nothing more than an electronic 12 pole two position switch but it has one advantage over a massive switch—the switching can be optionally controlled by a single TTL level signal. In the prototype I have used a small toggle switch to select the printer, but you may use any method you want.

By now some readers are probably wondering why a software switching system was not used, for example, detecting an 'escape' code sequence to select the printer through the data being transferred. There are a number of traps in that approach, one of the hardest to overcome being the problem of bit image graphics where a pseudo escape sequence can occur in the middle of a graphics data dump.

To explain further, when a printer is being sent normal text there is a number of non-printing control codes used to select printer options like enlarged printing, different line spacing, subscripts etc. Most of these are done in so-called escape sequences, where the ESC character code

(27 decimal) is first sent and then the next two characters received are not printed, but used to define a unique control code sequence. This system works because the ESC code is not used for any other purpose in ASCII text. When graphics data is being sent, any 8-bit code can occur however, and it is likely that the number used for ESC will come up sooner or later. This does not cause problems for the printer because the protocol for graphics data transfers is rigidly defined—the printer 'knows' that the data is for graphics and does not interpret any pseudo control codes.

But if the printer switch was to use an escape sequence to change printers, it too would have to 'know' when a graphics dump was occurring and ignore the data until the dump was over. This means the project would need to have inbuilt tables for the various types of printers on the market, and would almost certainly require a microprocessor. Once you have a micro on board there is a whole host of extra features that could be included such as 'spooling' or providing a buffer memory, conversion from one data format/ baud rate to another etc. However, as this seems to be getting away from the concept of a printer switch, the simple approach was adopted for this project.

Construction

The overall cost of the project is largely determined by the choice of connectors for

the Centronics ports. The pc board has been laid out to take 26-way pin headers with two rows of 13 pins spaced 1/10 inch between rows and pins. These can connect to insulation displacement (ID) transition connectors and thence to ID Centronics plugs and sockets, via ribbon cable. This method was used for the prototype, although many readers will want to save some money by using solder-type Centronics connectors and soldering the wires straight to the pc board.

If you use pin headers it will be necessary to cut some pins off the printer 2 header and the computer header. You can check the header against the pc board to see which pins to cut—they are the ground pins numbered 20 to 30 on the Centronics port. (There was no way to get the signal tracks through if the ground pins were left, without going to a double sided pc board or a lot of extra links.)

The only ground to the pc board from the computer port will be through Centronics pin 19 if the ID construction method is used. I had trouble with one supposed 'Centronics' interface that did not connect pin 19, so be warned! You could run a wire along the upper side of the pin header to connect pins 20 to 30 to pin 19, but if you do, try to keep all solder blobs to a minimum size so the transition connector has plenty of pin length left to contact the socket.

If you are using ID connectors you will need 26-way ribbon cable between the headers and Centronics plugs/socket. Crimp the ribbon down at the pin 1 end of the Centronics connectors. Constructors using solder-type Centronics connectors should connect pins 19 to 30 together with a wire on the back of the connectors, thence to the pc board.

Start the pc board by soldering in the 10 links. If you use uninsulated wire be careful to pull the wire tight to avoid shorts. The resistors can be wired in next, followed by the two capacitors and the transistor. The five ICs can go in now; all DIL types mount with the same orientation (most of them



HOW IT WORKS — ETI-666

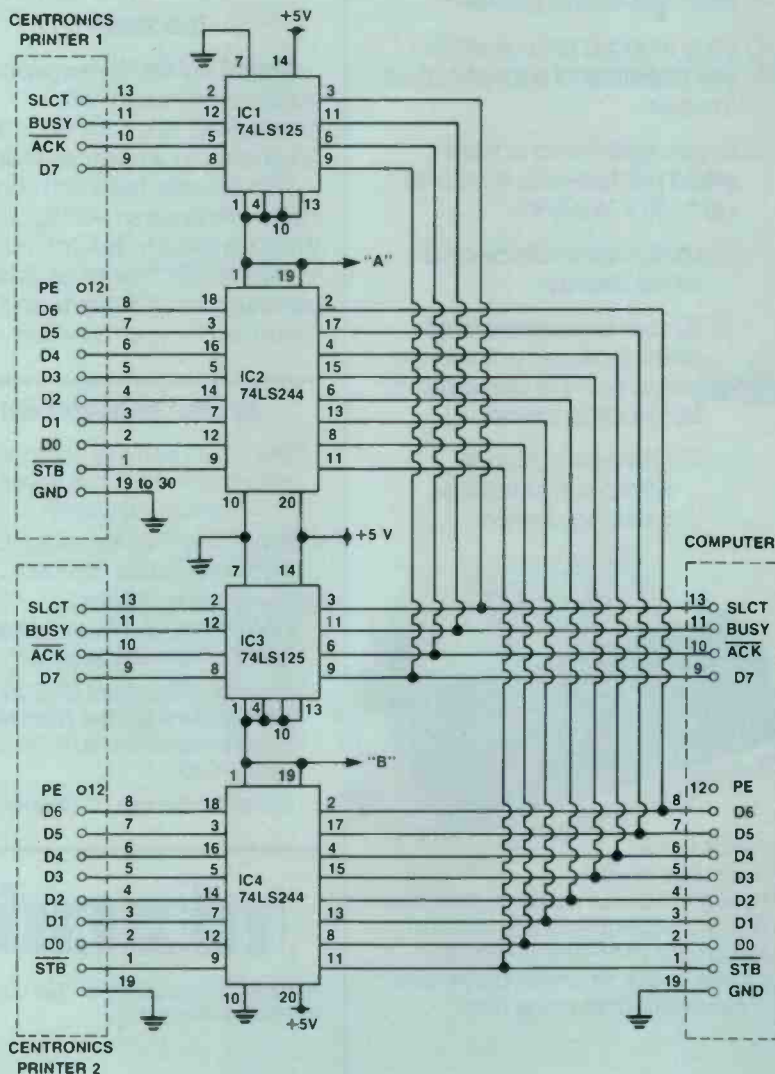

The circuit uses tristate buffers to interface the 12 Centronics signals from the computer to the two printers. Nine of the signals go from the computer to the printer (D0 to D7 and STB-BAR) while the remaining three signals come from the printer to the computer (SLCT, BUSY/READY-BAR and ACK-BAR).

When printer 1 is selected, the tristate outputs of IC1 and IC2 are enabled while the outputs of IC3 and IC4 go into the high impedance state. The reverse happens for printer 2. The printer selection switch directly controls the output enables for IC1 and IC2, while transistor Q1 inverts the switch level to control IC3 and IC4.

This ensures that each computer output line drives only one line at once. Similarly only one set of printer return signals is connected back to the computer, from the selected printer.

IC5 regulates the dc input voltage from the plug pack to provide the 5 V supply required for the TTL buffers.

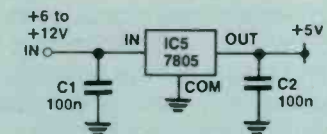
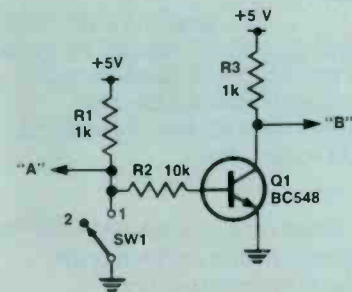

Circuit-Board-Design Without the Tedium

smARTWORK™ lets the design engineer create and revise printer-circuit-board artwork on the IBM Personal Computer.

Forget tape. Forget ruling. Forget waiting for a technician, draftsman, or the CAD department to get to your project. smARTWORK™ software turns your IBM Personal Computer into a professional, high-quality drafting tool. It gives you complete control over your circuit-board artwork—from start to finish.



smARTWORK™ transforms your IBM PC into a CAD system for printed-circuit-board artwork. Display modes include both single-layer black and white and dual-layer color.

What makes smARTWORK™ so smart is that it understands electrical connections. Conductor spacing is always correct, lines don't become too narrow, and connecting lines do not intersect other conductors. smARTWORK™ can automatically find and draw the shortest route between two conductors. Or you can specify the route.

smARTWORK™ is the only low-cost printed-circuit-board artwork editor with all these important advantages:

- Complete interactive control over placement and routing
- Quick correction and revision
- Production-quality 2X artwork from pen-and-ink plotter
- Prototype-quality 2X artwork from dot-matrix printer
- Easy to learn and operate, yet capable of sophisticated layouts
- Single-sided and double-sided printed-circuit boards up to 10 x 16 inches
 - Multicolor or black-and-white display
 - 32 user selectable color combinations; coincident points can be displayed in contrasting colors.
 - Can use optional Micro-soft Mouse as pointing device.

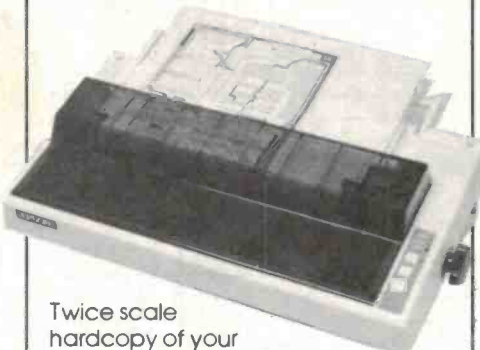

Twice scale hardcopy of your artwork is produced using the Epson dot-matrix printers or the Houston Instrument DMP-42 pen-and-ink plotter. Quick 1X check plot is also available from Epson printers.

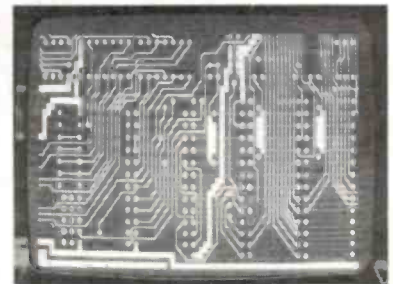

Dual-layer color display of a 2" by 4" section of a 10" by 16" circuit board

The Smart Buy

smARTWORK™ is exceptional value, particularly when compared to conventional engineering workstation costs.

Call or write to us for more information on smARTWORK™. We'll be glad to tell you how smARTWORK™ helps us design our own circuit boards and what it can do for your business.

System Requirements

- IBM PC, XT or close compatible with 192K RAM, 2 disk drives and DOS Version 2.0 or later.
- IBM Color/Graphics Adaptor with RGB color or B&W monitor.
- Epson MX80/MX100 or FX80/FX100 dot matrix printer or compatible with Grafrax.
- Houston Instrument DMP-42 pen-and-ink plotter (preferred). Small Houstons and HP7475A also supported.
- Microsoft Mouse (Optional).

microtrix

™smARTWORK™ and "Wintek" are trademarks of Wintek Corporation.

Australian Distributors: Microtrix Pty. Ltd. 24 Bridge Street, Eltham, Victoria. (03) 439 5155

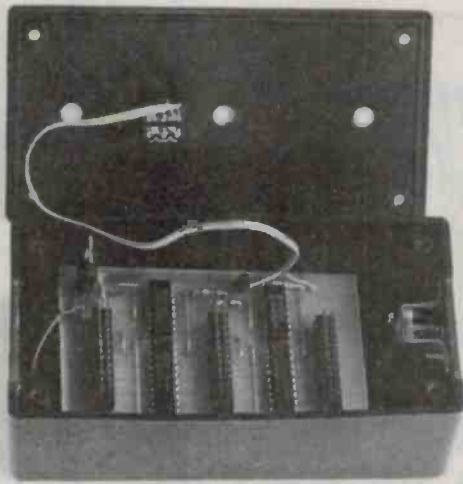

The Inside view. Note the position of the switch and socket. The ID cables have been removed.

have pin 1 marked with a dot on the pc board). Remember that IC5 is the regulator in the TO-220 package.

I mounted the printer selector switch along the long axis of the box lid, 48 mm from the end where the printer 1 cable comes out. If you are using a different box, be careful to avoid fouling the back of the switch on one of the pin headers.

Connect two pairs of hookup wire for the leads to the power supply and the printer selector switch. The power supply input should be wired to a socket suitable for the

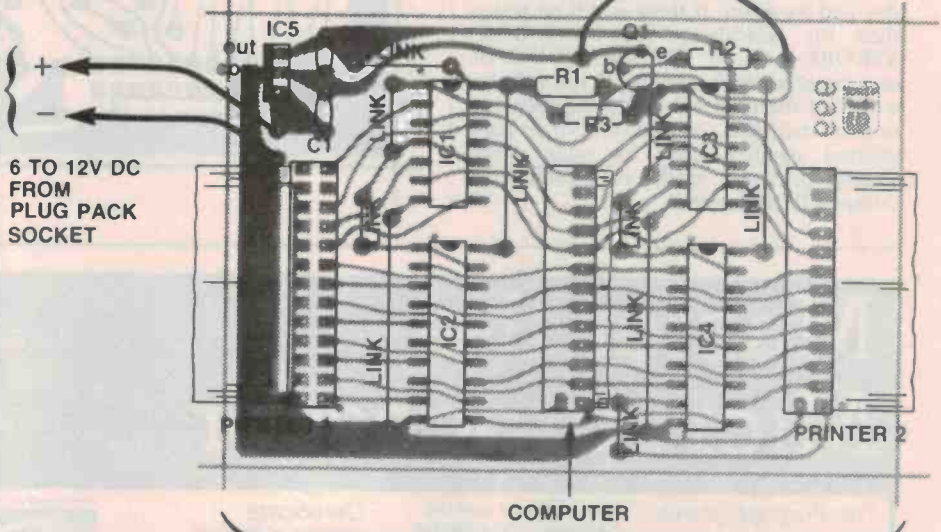

Close up of the pc board.

ALL 26 WIRE RIBBON CABLE WITH OPTIONAL SOCKETS.

PARTS LIST — ETI-666

Resistors
 R1, R2 1k0 5% 1/4 W
 R2 10k 5% 1/4 W

Capacitors
 C1, C2 100 nF ceramic bypass caps

Semiconductors
 IC1, IC3 74LS125 Quad tristate buffer
 IC2, IC4 74LS244 Octal tristate buffer
 IC5 7805 +5 V Regulator
 Q1 BC548 etc NPN transistor

Connectors
 Either insulation displacement types
 3 x 26-way pin headers
 3 x 26-way ID transition sockets
 2 x Centronics ID plugs
 1 x Centronics ID sockets
 or solder types
 2 x Centronics solder plugs
 1 x Centronics solder socket

Miscellaneous
 ETI-666 printed circuit board; single pole single throw switch; 6 to 12 V dc plug pack; socket to suit plug pack; plastic case to take 60 x 90 mm pc board; 26-way ribbon cable; hookup wire, link wire, solder etc.

Price estimate: \$25
(not including connectors)
\$50-\$70
(including connectors)

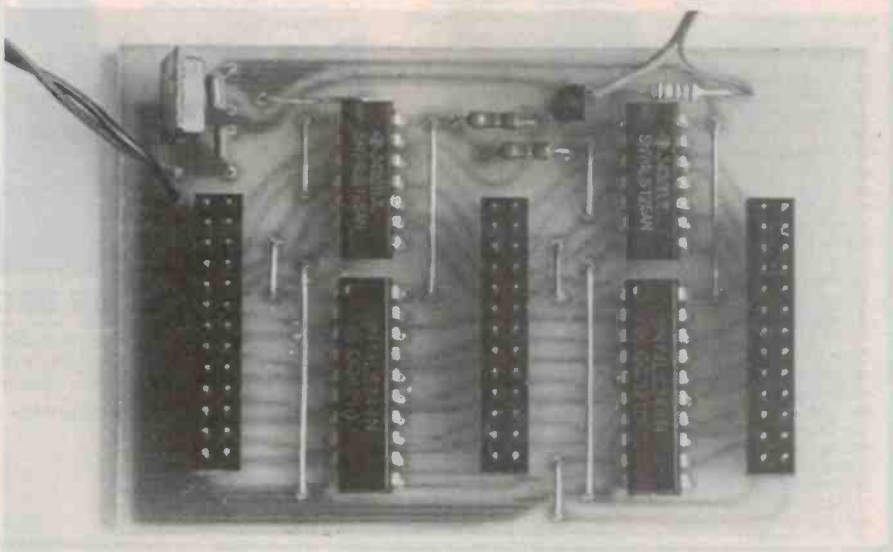

plug pack to be used. Watch the polarity and note that the plug pack must produce a dc voltage between 6 and 12 V.

I filed away part of the box to allow the ribbon cables to pass under the mounted lid. Two of the cables pass out one end, with the remaining one out the other.

Testing

Carefully check all wiring and look over the pc board for solder blobs, especially where a track runs between IC pads. When all seems well, connect a multimeter across C2 and power up. The voltage reading should be within 200 mV of 5.0 V. If it isn't, stop and find the fault before connecting the printers or computer to the project.

Once the voltage is correct you can plug the computer and printers in and try printing on each printer in turn. If nothing happens at first, try resetting the computer then switch each printer off-line then back on-line and try again. If there is still no action then the handshake lines ACK-BAR, STROBE-BAR or BUSY/READY-BAR may be stuck high or low. If the printers work but the print-out is garbled then one or more data lines could be stuck or perhaps shorted together. Look for solder blobs joining pc board tracks or insufficiently crimped ID connectors.

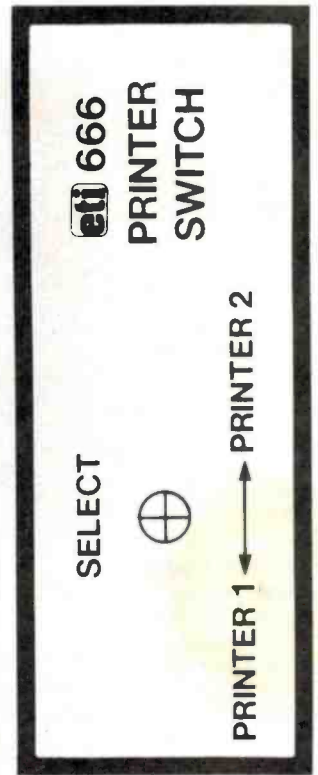
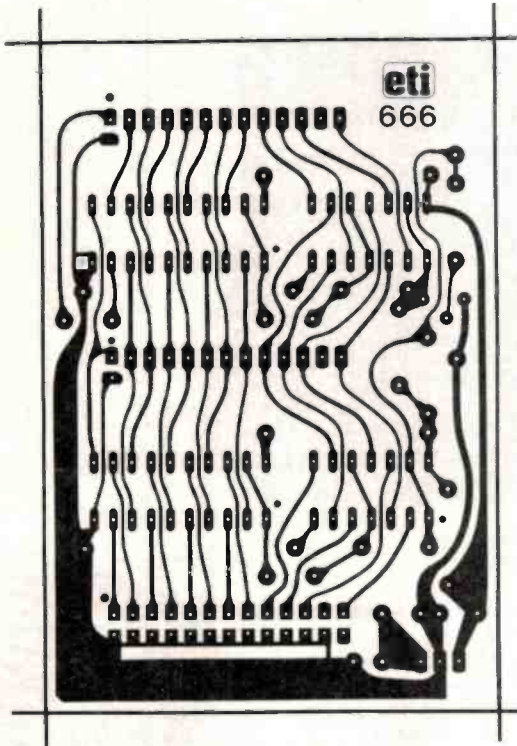

Master the Microprocessor

Learn how Microprocessors really work ... the practical way.

The Purpose of this Course

There is a considerable, expanding and world-wide demand for people with a real knowledge of microprocessors and general computer technology. Such people are needed to design and evaluate systems and to assess and develop the enormous range of possible applications, both present and future, of microprocessors and to understand the installation and servicing of the main types of equipment of which they may form the most vital component.

(A microcomputer has already been produced to replace the mechanical programmer on a domestic washing machine, for example.)

This Course provides the necessary basic information to enable a student to really understand the functioning of microprocessors and their supporting circuitry,

usually referred to as the "hardware". This is backed up by showing how to program a microcomputer (or produce its "software") in the most fundamental form of computer language called "machine code". No previous knowledge of computers is necessary, though a little basic knowledge of electronics plus digital and logic circuits will be found helpful.

A special introductory short course is available to provide this back-ground information, if required by an individual student on the course without extra fee.

Student—Tutor Contact

A qualified Tutor is available to every Student throughout this Course in order to deal with any queries which may arise and to assess certain questionnaires which are issued to Students throughout the period of training.

Certificate
Issued to all Students completing the Course successfully. Course covers main requirements of the City and Guilds Certificates in Computers.

Practical Self Study Course



FREE COLOUR BROCHURE

Post coupon now: The Australian School of Electronics Pty. Ltd., P.O. Box 108, Glen Iris, Victoria, 3146. Offices at: 219 Balaclava Rd., Caulfield North.

Please send your brochure without any obligation to:

Name

Address

Postcode

How the Course is organised

The basis for the practical work in the Course is the Microcomputer. This is supplied completely assembled and ready to use.

The Course text is carefully arranged in sequence so that each new section follows logically from previous work. Hardware description and programming technique progress together, so that the Student is discouraged from treating them as distinctly separate subjects. Following each section of descriptive text, detailed instructions are given in order to use the Microcomputer to provide a practical demonstration of each new function or technique. This provides a very powerful way of learning precisely how the system operates, and enables any possible ambiguities in the Student's mind to be quickly resolved.

DIGITAL MULTIMETERS

FROM **BENELEC**

THREE MODELS TO CHOOSE FROM —

All 3½-digit LCD Meters Featuring 0.5% (dc) Basic Accuracy 'Professional' Instruments at a Hobbyist Price!

BENELEC PTY LTD had such a resounding success with a previous offer made through Electronics Today that they approached us about launching two new multimeters in their Univolt range in the same way.

Univolt is no new brand to the Australian market. BENELEC has been distributing Univolt multimeters here for the past five years. The instruments are designed, developed, manufactured and marketed under the company name — no 'badge' engineering here. These meters are imported exclusively by BENELEC PTY LTD who warranty and service them here. They've been in the electronics business for over eight years and believe in handling quality products.

Here's an incredible opportunity to get the sort of multimeter to suit your needs at virtually unbeatable prices!

Univolt's continuing design and development program has brought two new models to the marketplace and this is the first time the DT-1000 and PD-1800 models have been offered here. The DT-860 was first offered two years ago and, as a sort of 'anniversary deal', Benelec are again offering the DT-860, but this time at a lower price!

DON'T MISS OUT — ORDER NOW!

Send completed coupon to:
Federal Marketing, BENELEC/ETI Multimeter Offer,
PO Box 227, Waterloo NSW 2017.

I don't want to miss out on this special offer.
Please rush me the following:

..... DT-1000 Multimeter(s) at \$
..... PD-1800 Multimeter(s) at \$
..... DT-860K Multimeter(s) at \$

Sales Tax No: (if applicable)

Please add \$2.50 post and handling per unit ordered.

TOTAL \$

(allow up to four weeks for delivery)

Name

Address

Postcode

Signature

American Express Bankcard Cheque*

* Please make cheques payable to the Federal Publishing Company Pty. Ltd.

Credit Card No:

Expiry Date:

OFFER CLOSES LAST MAIL SUNDAY 31 MARCH

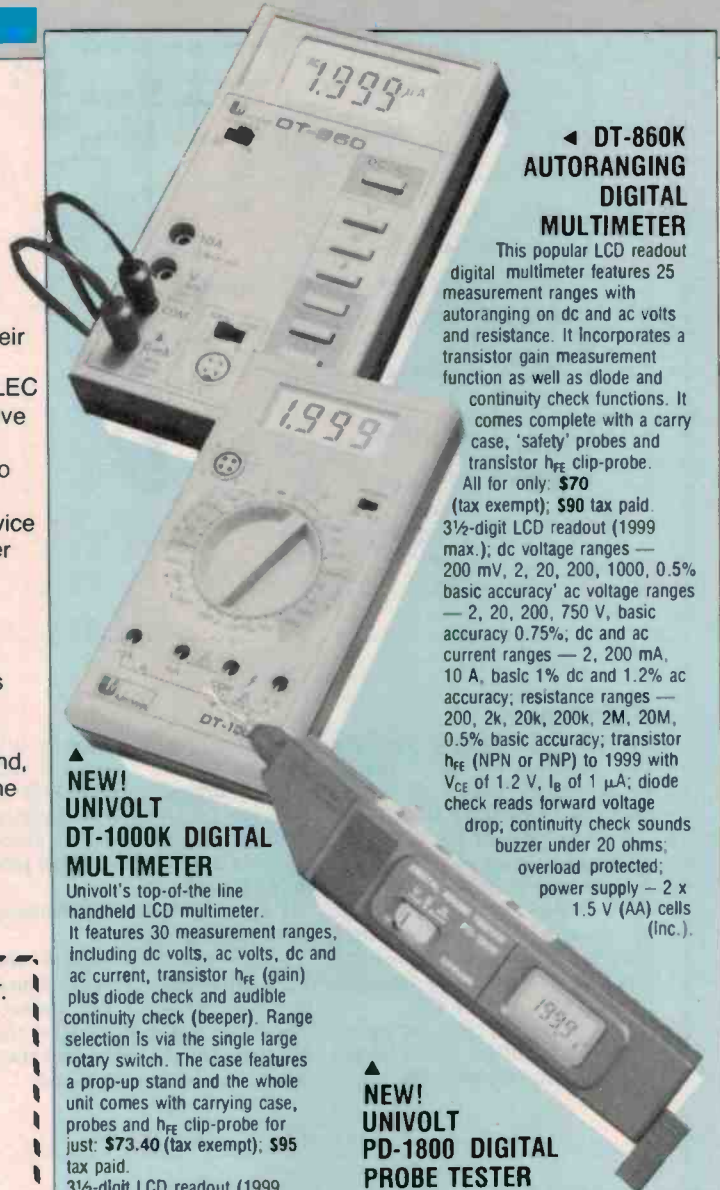

DT-860K AUTORANGING DIGITAL MULTIMETER

This popular LCD readout digital multimeter features 25 measurement ranges with autoranging on dc and ac volts and resistance. It incorporates a transistor gain measurement function as well as diode and continuity check functions. It comes complete with a carry case, 'safety' probes and transistor h_{FE} clip-probe.

All for only: **\$70** (tax exempt); **\$90** tax paid. 3½-digit LCD readout (1999 max.); dc voltage ranges — 200 mV, 2, 20, 200, 1000, 0.5% basic accuracy; ac voltage ranges — 2, 20, 200, 750 V, basic accuracy 0.75%; dc and ac current ranges — 2, 200 mA, 10 A, basic 1% dc and 1.2% ac accuracy; resistance ranges — 200, 2k, 20k, 200k, 2M, 20M, 0.5% basic accuracy; transistor h_{FE} (NPN or PNP) to 1999 with V_{CE} of 1.2 V, I_B of 1 μ A; diode check reads forward voltage drop; continuity check sounds buzzer under 20 ohms; overload protected; power supply — 2 x 1.5 V (AA) cells (Inc.).

NEW! UNIVOLT DT-1000K DIGITAL MULTIMETER

Univolt's top-of-the-line handheld LCD multimeter. It features 30 measurement ranges, including dc volts, ac volts, dc and ac current, transistor h_{FE} (gain) plus diode check and audible continuity check (beeper). Range selection is via the single large rotary switch. The case features a pop-up stand and the whole unit comes with carrying case, probes and h_{FE} clip-probe for just: **\$73.40** (tax exempt); **\$95** tax paid. 3½-digit LCD readout (1999 max.); dc voltage ranges — 200 mV, 2, 20, 200, 1000 V, 0.5% basic accuracy; ac voltage ranges — as for dc but 750 V on top range, basic 1% accuracy; dc and ac current ranges — 200 μ A, 2, 20, 200 mA, 10 A, 1% basic accuracy on dc, 1.2% on ac; input impedance — 10M; resistance ranges — 200, 2k, 20k, 200k, 2M, 20M, 1% basic accuracy; transistor h_{FE} (NPN or PNP) to 1000 with V_{CE} of 2.0 V, I_B of 10 μ A; diode check reads forward voltage drop; continuity check sounds buzzer under 20 ohms; overload protected; power supply — 9 V No. 216 battery (Inc.).

NEW! UNIVOLT PD-1800 DIGITAL PROBE TESTER

Wow! — a tiny digital volt-ohm-continuity probe with the 3½-digit LCD readout built-in! Great for the toolkit, great for the beach! It features autoranging on volts and ohms as well as autopolarity indication. A beeper sounds in the continuity test mode. There are four dc and ac voltage ranges and four resistance ranges. It measures a tiny 163 mm long, 28 mm high and 19 mm deep! How much? **\$50** (tax exempt); **\$65** tax paid.

3½-digit LCD readout (1999 max.); ac and dc voltage ranges — 2, 20, 200, 500 V, basic accuracy 0.5% dc, 1% ac; resistance ranges — 2k, 20k, 200k, 2M, basic accuracy 0.7% (in-circuit test capability — uses 0.3 V on ohms range); input impedance — above 10M; power supply — 2 x 1.5 V (LR-44) cells (Inc.).

This offer is exclusive to readers of Electronics Today and products can only be obtained by sending in the attached coupon (or a clear photostat or hand-copied facsimile). **90 DAY WARRANTY ON ALL METERS** (from date of despatch).

IDEAS FOR EXPERIMENTERS

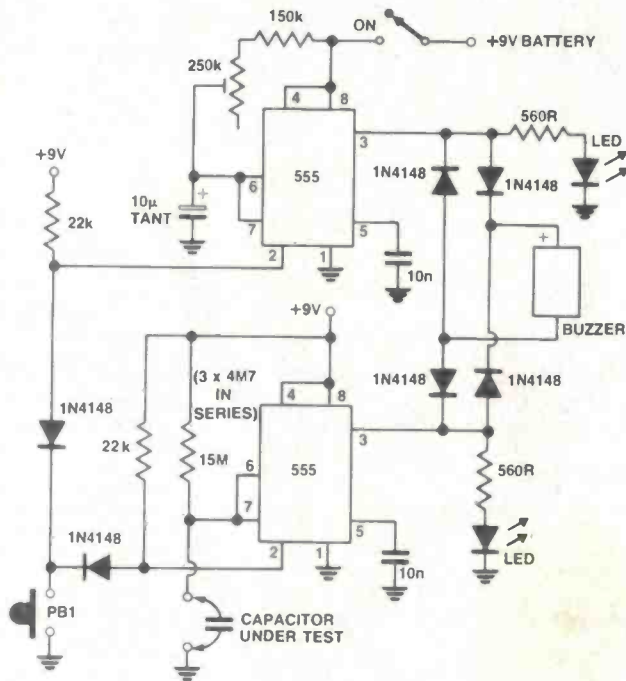

Capacitance tester

A. Glover of Cootamundra NSW 2590 sent us this idea for a simple, ultra low cost capacitance tester. It works by comparing the value of a known capacitor with one under test. The amount of time the voltage on pin 3 of the 555 is high is proportional to the value of the capacitance hanging off pin 6 and 7. In the circuit shown, when the two capacitors are of the same value the LEDs will be on for the same length of time and the buzzer will not sound. Any discrepancy in value will result in one LED being on for longer than the other and the buzzer sounding.

Flasher

M. Howe of Mitcham, Vic used this variation on the common LED flasher theme in which daylight controls the flasher.

During daylight hours RV2 is adjusted to keep voltage at pins 2 and 6 of IC1 just below 2/3 Vcc. As darkness falls the resistance across the LDR increases until pin 6 sees 2/3 rail voltage and the 555 starts to operate, flashing the light via Q1.

When the sun rises the opposite occurs and C1 is effectively shorted out, stopping the 555.

The prototype, using a 6 V battery, flashes every 1-2 seconds. Current consumption in daylight is 2.4 mA. Operating current depends on the globe used. In daylight RV2 holds pins 2 and 6 at 3.8 V.

I used a BD140 as Q1 because I had a few to spare.

All components except the LDR and light-bulb will fit on a pc board only 25 mm square. The LDR is not affected by the operation of the globe and they can be mounted side by side.

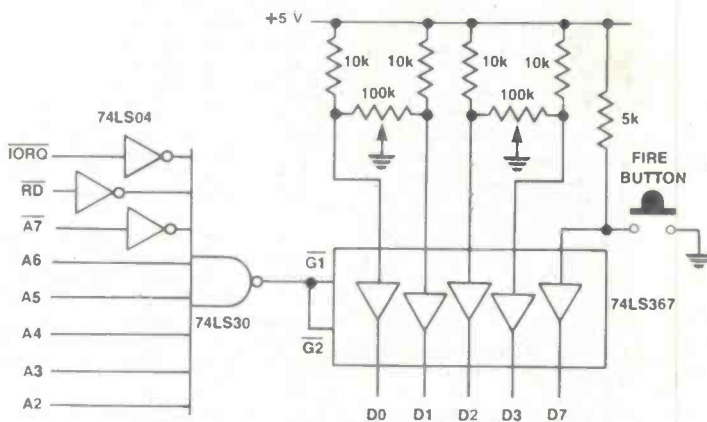
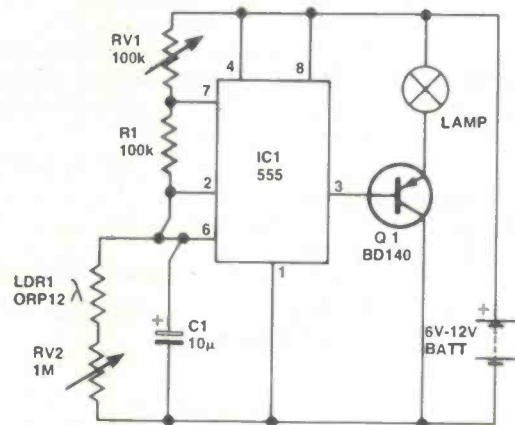

Nine position joystick

This simple circuit was sent to us by R. Howie of Mansfield Qld. It should work with any computer running the Z80 processor and equipped with an expansion port. The two joystick pots are used as voltage dividers for the 74LS367. Gating signals are supplied from the computer via the 74LS30. This circuit is cheap and very easy to build.

IDEA OF THE MONTH

Headlight Warning

Jeff Lefaro, Mulgrave Vic 3170

To help prevent leaving the car lights on after switching off the engine, and thus flattening the battery, a simple circuit such as

this one can be implemented. The circuit consists of an oscillator which can be enabled or frozen with respect to the inputs on IC1b. If both these inputs are high then there will be no current passing through D1 and the oscillator can produce the

desired tone.

The frequency output is proportional to R4 and C1, and can be varied to suit, although R4 should not be reduced to less than 5k. The value of C1 should not be changed drastically as the output may become inaudible.

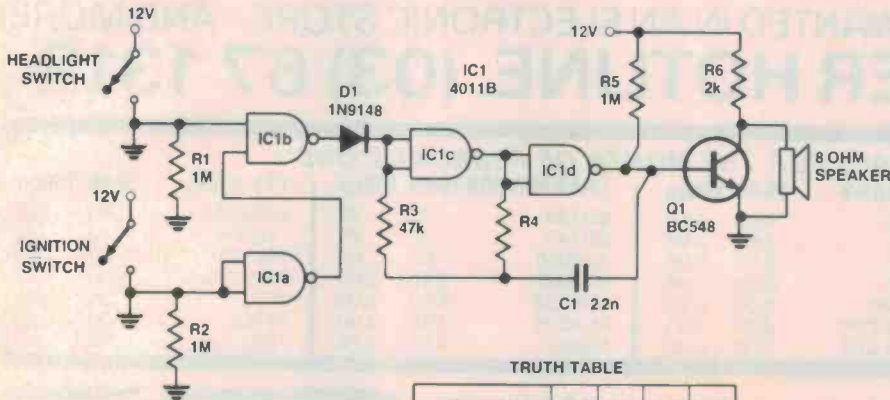

TRUTH TABLE

IGNITION	OFF	ON	OFF	ON
HEADLIGHTS	OFF	OFF	ON	ON
OSCILLATOR	OFF	OFF	ON	OFF

"RELAYS" AGAIN

Contact material

Further to the article which appeared in the February 84 edition of ETI, Donald Sutherland of Wanganui, NZ has written to us noting a method of determining the materials of which a contact is made, at least for the BPO 3000 and 600 types. The shape of the spring tips indicates the contact material.

CONTACTS



METHOD OF INDICATING CONTACT MATERIAL

'IDEA OF THE MONTH' CONTEST

COUPON

Cut and send to: Scope/ETI 'Idea of the Month' Contest, ETI Magazine, P.O. Box 227, Waterloo NSW 2017.

"I agree to the above terms and grant *Electronics Today International* all rights to publish my idea in ETI Magazine or other publications produced by it. I declare that the attached idea is my own original material, that it has not previously been published and that its publication does not violate any other copyright."

* Breach of copyright is now a criminal offence.

Title of Idea

Signature

Name

Date

Address

Postcode

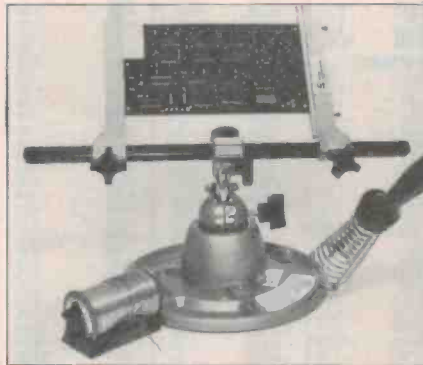

PRIZE WORTH \$123!

Scope pc board Work Centre

Scope Laboratories, which manufactures and distributes soldering irons and accessory tools, is sponsoring this contest with a prize given away every month for the best item submitted for publication in the 'Ideas for Experimenters' column — one of the most consistently popular features in ETI Magazine. Each month we will be giving away a pc board Work Centre consisting of the Model 315 adjustable pc board holder with capacity to accept 300 mm boards, Model 300 180° swivel and lock base which can be attached to the Model 312 tray base with wet sponge receptacle, Model 371 solder spool holder and Model STS 3 soldering iron safety stand. Please note prize does not include solder or scope TC60 temperature controlled iron shown above. The prize is worth \$123!

Selections will be made at the sole discretion of the editorial staff of ETI Magazine. Apart from the prize, each winner will be paid \$10 for the item published. You must submit original ideas of circuits which have not previously been published. You may send as many entries as you wish.

RULES

This contest is open to all persons normally resident in Australia, with the exception of members of the staff of Scope Laboratories, The Federal Publishing Company Pty Limited, ESN, The Litho Centre and/or associated companies.

Closing date for each issue is the last day of the month. Entries received within seven days of that date will be accepted if postmarked prior to and including the date of

the last day of the month.

The winning entry will be judged by the Editor of ETI Magazine, whose decision will be final. No correspondence can be entered into regarding the decision.

The winner will be advised by telegram the same day the result is declared. The name of the winner, together with the winning idea, will be published in the next possible issue of ETI Magazine.

Contestants must enter their names and addresses where indicated on each entry form. Photostats or clearly

written copies will be accepted but it sending copies you must cut out and include with each entry the month and page number from the bottom of the page of the contest. In other words, you can send in multiple entries but you will need extra copies of the magazine so that you send an original page number with each entry.

This contest is invalid in states where local laws prohibit entries. Entrants must sign the declaration on the coupon that they have read the above rules and agree to abide by their conditions.



ACTIVE ELECTRONICS

289 LATROBE STREET, MELBOURNE 3000 PH. 602 3499

8.30 - 5.30 pm MON-THURS 8.30 - 8.30 pm FRIDAYS 9 am - 12 noon SATURDAY

ALL YOU HAVE EVER WANTED IN AN ELECTRONIC STORE - AND MORE!

MAIL ORDER HOTLINE. (03) 67 1312

SUPER SPECIALS FOR THE MONTH OF FEBRUARY ONLY

LINEAR	10-99	100up	MEMORY	10-99	100up	TRANSISTORS	10-99	100up	TTL & LS	10-99	100up
LM555	.35	.25	2716	4.95	4.50	BD139	.35	.25	74LS00	.30	.25
LM741	.35	.25	2732	5.50	4.95	BD140	.35	.25	74LS08	.30	.25
LM324	.40	.35	2764	6.50	5.95	2N3055	.65	.60	74LS74	.35	.29
7805UC	.60	.50	4164	6.00	4.95	BUX80	2.95	2.60	74LS245	1.20	.95
78HO5KC	7.25	6.50	6116P3	6.00	5.50	MJ4032	4.50	3.00	7400	.35	.33
78H12KC	7.50	6.95	Z80A CPU	3.50	2.95	MJ4035	4.50	3.00	74150	1.20	1.10
78S12KC 2 amp	2.20	1.95	Z80A SIO	7.00	6.40	MJ802	3.50	3.20	7402	.35	.33

MAIL ORDER

MAIL ORDER

MAIL ORDER

MAIL ORDER

MAIL ORDER

MAIL ORDER

MAIL ORDER

MAIL ORDER

TOP PRICES ON DISKETTES

Single side

\$22.50

Double Sided

\$39.50



Verbatim

TTL	74178	2.15	74LS139	.80	74F86	1.19	74C73	1.40	4078	1.10
7400	74180	1.20	74LS151	1.20	74F109	.98	74C74	1.70	4029	1.40
7401	74182	1.50	74LS152	1.99	74F138	1.79	74C76	1.90	4030	1.10
7402	74184	4.80	74LS153	1.00	74F139	1.79	74C83	2.30	4031	2.95
7403	74190	1.50	74LS154	1.00	74F151	1.79	74C85	1.95	4032	2.75
7404	74191	1.20	74LS155	1.00	74F153	1.79	74C86	1.50	4033	2.75
7406	74192	1.60	74LS156	1.50	74F157	1.79	74C89	8.90	4034	3.50
7407	74193	.80	74LS157	1.10	74F158	1.79	74C90	1.90	4035	1.95
7409	74194	1.10	74LS158	1.00	74F175	2.78	74C93	1.90	4040	1.20
7410	74195	1.00	74LS160	1.00	74F181	5.98	74C95	2.00	4041	1.50
7412	74197	1.20	74LS161	1.20	74F182	2.73	74C107	1.20	4042	1.00
7413	74198	2.10	74LS162	1.50	74F189	7.44	74C150	6.50	4043	1.60
7414	74199	2.20	74LS163	1.10	74F190	4.86	74C151	4.20	4044	1.20
7416	74201	1.90	74LS164	.90	74F191	4.86	74C154	6.00	4046	1.80
7417	74202	1.70	74LS165	1.00	74F194	2.41	74C157	3.75	4047	1.20
7420	74203	1.20	74LS166	2.55	74F241	3.72	74C160	1.90	4048	1.20
7421	74204	1.20	74LS169	2.45	74F242	4.34	74C161	1.90	4049	.75
7422	74205	2.45	74LS170	.90	74F243	3.72	74C162	2.00	4050	.75
7423	74206	.90	74LS171	.90	74F251	1.93	74C163	2.00	4051	1.30
7425	74207	.90	74LS172	.80	74F252	1.93	74C164	2.50	4052	1.50
7426	74208	2.45	74LS173	1.00	74F258	1.93	74C165	2.50	4053	1.50
7427	74209	1.50	74LS174	1.20	74F350	4.34	74C173	1.90	4055	3.90
7428	74210	1.50	74LS175	1.20	74F352	1.93	74C174	1.90	4060	1.80
7430	74211	1.50	74LS176	1.20	74F353	1.93	74C175	1.90	4063	1.80
7432	74212	1.00	74LS177	1.20	74F373	4.84	74C192	2.00	4066	1.10
7437	74213	1.00	74LS178	1.20	74F374	4.84	74C195	2.90	4067	4.95
7438	74214	1.90	74LS179	1.20	74F374	4.84	74C200	14.00	4068	.45
7440	74215	.35	74LS180	1.20	74F399	2.78	74C221	2.75	4070	.80
7442	74216	.40	74LS181	1.90	74F521	4.22	74C221	2.75	4071	.40
7443	74217	.40	74LS182	1.90	74F521	4.22	74C221	2.75	4072	.80
7444	74218	.40	74LS183	1.90	74F533	4.84	74C221	2.75	4073	.80
7445	74219	.50	74LS184	1.90	74F534	4.84	74C221	2.75	4074	.80
7446	74220	.50	74LS185	1.90	74F534	4.84	74C221	2.75	4075	.80
7447	74221	.50	74LS186	1.90	74F534	4.84	74C221	2.75	4076	1.50
7448	74222	.50	74LS187	1.90	74F534	4.84	74C221	2.75	4077	.80
7450	74223	.50	74LS188	1.90	74F534	4.84	74C221	2.75	4078	.80
7451	74224	.50	74LS189	1.90	74F534	4.84	74C221	2.75	4079	.80
7452	74225	.50	74LS190	1.90	74F534	4.84	74C221	2.75	4080	.80
7453	74226	.50	74LS191	1.90	74F534	4.84	74C221	2.75	4081	.80
7454	74227	.50	74LS192	1.90	74F534	4.84	74C221	2.75	4082	.55
7456	74228	.50	74LS193	1.90	74F534	4.84	74C221	2.75	4083	1.80
7457	74229	.50	74LS194	1.90	74F534	4.84	74C221	2.75	4084	1.80
7458	74230	.50	74LS195	1.90	74F534	4.84	74C221	2.75	4085	1.80
7459	74231	.50	74LS196	1.90	74F534	4.84	74C221	2.75	4086	1.80
7460	74232	.50	74LS197	1.90	74F534	4.84	74C221	2.75	4087	3.50
7461	74233	.50	74LS198	1.90	74F534	4.84	74C221	2.75	4088	1.90
7462	74234	.50	74LS199	1.90	74F534	4.84	74C221	2.75	4089	1.90
7463	74235	.50	74LS200	1.90	74F534	4.84	74C221	2.75	4090	1.90
7464	74236	.50	74LS201	1.90	74F534	4.84	74C221	2.75	4091	1.90
7465	74237	.50	74LS202	1.90	74F534	4.84	74C221	2.75	4092	1.90
7466	74238	.50	74LS203	1.90	74F534	4.84	74C221	2.75	4093	1.90
7467	74239	.50	74LS204	1.90	74F534	4.84	74C221	2.75	4094	1.90
7468	74240	.50	74LS205	1.90	74F534	4.84	74C221	2.75	4095	1.90
7469	74241	.50	74LS206	1.90	74F534	4.84	74C221	2.75	4096	1.90
7470	74242	.50	74LS207	1.90	74F534	4.84	74C221	2.75	4097	1.90
7471	74243	.50	74LS208	1.90	74F534	4.84	74C221	2.75	4098	1.90
7472	74244	.50	74LS209	1.90	74F534	4.84	74C221	2.75	4099	1.90
7473	74245	.50	74LS210	1.90	74F534	4.84	74C221	2.75	4100	1.90
7474	74246	.50	74LS211	1.90	74F534	4.84	74C221	2.75	4101	1.90
7475	74247	.50	74LS212	1.90	74F534	4.84	74C221	2.75	4102	1.90
7476	74248	.50	74LS213	1.90	74F534	4.84	74C221	2.75	4103	1.90
7477	74249	.50	74LS214	1.90	74F534	4.84	74C221	2.75	4104	1.90
7478	74250	.50	74LS215	1.90	74F534	4.84	74C221	2.75	4105	1.90
7479	74251	.50	74LS216	1.90	74F534	4.84	74C221	2.75	4106	1.90
7480	74252	.50	74LS217	1.90	74F534	4.84	74C221	2.75	4107	1.90
7481	74253	.50	74LS218	1.90	74F534	4.84	74C221	2.75	4108	1.90
7482	74254	.50	74LS219	1.90	74F534	4.84	74C221	2.75	4109	1.90
7483	74255	.50	74LS220	1.90	74F534	4.84	74C221	2.75	4110	1.90
7484	74256	.50	74LS221	1.90	74F534	4.84	74C221	2.75	4111	1.90
7485	74257	.50	74LS222	1.90	74F534	4.84	74C221	2.75	4112	1.90
7486	74258	.50	74LS223	1.90	74F534	4.84	74C221	2.75	4113	1.90
7487	74259	.50	74LS224	1.90	74F534	4.84	74C221	2.75	4114	1.90
7488	74260	.50	74LS225	1.90	74F534	4.84	74C221	2.75	4115	1.90
7489	74261	.50	74LS226	1.90	74F534	4.84	74C221	2.75	4116	1.90
7490	74262	.50	74LS227	1.90	74F534	4.84	74C221	2.75	4117	1.90
7491	74263	.50	74LS228	1.90	74F534	4.84	74C221	2.75	4118	1.90
7492	74264	.50	74LS229	1.90	74F534	4.84	74C221	2.75	4119	1.90
7493	74265	.50	74LS230	1.90	74F534	4.84	74C221	2.75	4120	1.90
7494	74266	.50	74LS231	1.90	74F534	4.84	74C221	2.75	4121	1.90
7495	74267	.50	74LS232	1.90	74F534	4.84	74C221	2.75	4122	1.90
7496	74268	.50	74LS233	1.90	74F534	4.84	74C221	2.75	4123	1.90
7497	74269	.50	74LS234	1.90	74F534	4.84	74C221	2.75	4124	1.90
7498	74270	.50	74LS235	1.90	74F534	4.84	74C221	2.75	4125	1.90
7499	74271	.50	74LS236	1.90	74F534	4.84	74C221	2.75	4126	1.90
7500	74272	.50	74LS237	1.90	74F534	4.84	74C221	2.75	4127	1.90

MAIL ORDER

MAIL ORDER

MAIL ORDER

MAIL ORDER

MAIL ORDER MAIL ORDER MAIL ORDER MAIL ORDER MAIL ORDER MAIL ORDER MAIL ORDER

ULN2004 1.80 WD2143 14.50 TCA220 7.90 TDA200 5.50 TDA2030 5.50 XR2206 7.95 XR2207 7.05 XR2209 6.90 XR2211 7.45 XR2216 5.90 XR2243 7.95 M2560AB 9.90 Z851 23.00 WD2791 54.00 WD2793 50.00 WD2795 59.00 WD2797 59.00 TDA2822 7.50 LM2917 4.00 LM2917-14 4.90 L296 9.50 L297 12.00 L298 9.50 AY-3-10150 7.50 AY-3-891D 14.50 MN3001 17.50 LM301AN 5.00 LM301AHC 1.50 LM307N .95 LM307H 1.50 LM307B 2.00 CA-3046 1.90 CA-3059 5.95 LM3080 1.90 UA-3086 1.85 UA-3089 3.90 UA-308TC 1.90 UA-308ATC 2.50 UA-308HC 1.70 UA-308AHC 3.80 LM310N 3.20 LM311N 3.00 LM311H 1.75 LM318N 4.50 LM319N 4.90 CA3130E 2.10 8131 61.31 CA3130T 2.90 CA3140E 1.25 CA3140T 2.50 OM321 15.00 LM324 1.90 LM325 4.50 LM329DZ .90 LM334Z 1.90 MC3340 1.85 LM335Z 2.20 OM335 22.00 LM335Z-25V 2.80 LM339N 1.10 LM339AN 1.40 LM3401 1.00 LF347 3.20 MC3470 12.50 LM349 1.80 LF349N 1.80 OM350 10.50 LF361N 1.00 LF363N 1.80 LF366N 2.40 LF367N 2.40 LM368N 1.20 LM377 4.90 LM378 3.95 LM380-8 1.75 LM380-14 1.90 MC3340 1.85 LM381 2.70 LM382 2.50 LM383 3.50 LM384 3.50 LM386 1.80 LM387 2.00 LM388 1.80 LM389 2.00 LM3900 1.20 LM3905 1.75 LM3909 1.95 LM3911 2.00 LM3914 4.95 LM3915 5.50 LM3916 5.50 LM391 1.00 LM393 2.80 LM394 1.95 LF398N 5.50 UA4136 1.85 ZN414 1.95 LM4250 3.50 L465 12.50 MM5303 7.50 MM5309 13.95 MM5369 2.95 NE5534N 1.95 NE5534AN 2.95 NE655 4.00 NE556 1.00 NE558 4.95 NE556 1.60 NE556 2.75 NE567 1.95 NE567 1.95 NE571 5.50 MM58167 14.95 MMS8174 14.95 MMS832 15.50	6502 12.50 6502A 13.50 6505 13.00 6507 13.00 6520 5.40 6522 12.50 6522A 12.95 6532 13.50 6545 18.95 6551 12.90 LM709 1.30 UA710 1.00 ICL7106 11.95 ICM7127A 18.50 LM711N 1.10 LM711H 1.40 UA733 1.50 UA739 2.50 LM74IN 1.40 LM74IH 1.20 UA747 1.30 UA748 1.00 75107 2.20 75110 2.20 75150 2.20 75154 2.20 75451 .90 75452 .90 75453 .90 75454 1.60 75455 1.50 75462 2.00 75491 1.90 75492 1.90 M751 BI 9.50 ICM7555 2.75 ICM7556 2.95 M7518 12.50 SN76488 8.95 8035 6.90 8038 6.50 8039 7.90 8060 19.80 8080 19.80 8085 9.50 8121 1.70 8130 5.90 8131 5.90 8136 5.90 81LS 95 7.95 81LS 96 3.50 81LS 97 3.50 81LS98 3.50 8155 6.50 8156 10.50 8157 3.90 8212 2.90 8214 4.90 8216 2.90 8224 3.50 8226 4.50 8228 5.40 8238 9.50 8243 7.95 8251 4.90 8252 7.50 8255 5.50 8257 6.50 8259 6.50 8279 8.50 8303 4.95 8304 5.50 8741 55.00 8748 65.00 8749 58.00 8755 33.00 8726 2.95 8726 2.95 8728 2.95 8797 1.80 95H90 8.50	78505 UC 2.50 78512 UC 2.50 LM309K 1.90 LM317T 1.65 LM317K 3.50 LM317HUK 9.50 LM323K 6.50 LM337T 2.80 LM337K 6.35 LM338K 9.50 LM350T 4.95 LM350K 7.25 LM396K 18.95 UA494 4.50 LM723N 7.50 LM723H 1.50 78H05KC 8.95 78H12KC 8.95 78HGKC 9.40 78HGKC 15.50 78P05KC 15.95 7850 3.30 SH1605 19.08	DPT0 AN26 1.15 4N28 1.20 4N33 1.50 4N36 1.50 MCT6 2.50 MC T2 1.50 6N137 9.90 AD12 1.40 BPW34 3.00 BPW50 2.20 CQY89 1.20 FPT100B 3.50 FMD50 1.80 320R AC127 .20 AC128 1.20 AC187 1.50 AC188 1.45 AD149 3.00 AD161 1.75 AD162 1.75 BC107B .45 BC108 .45 BC108B .45 BC109 .40 BC109C .45 BC177B .50 BC178A .50 BC179 .50 MC3030 2.50 ORP12 2.80 TIL31A 2.95 TIL81A 2.95 TIL81H 2.50 TIL316 2.50 TL113A 3.00 5mm LED SGS .20 LCG113A 3.00 5mm LED SGS .25 TLY113A .17 5mm LED SGS .30 TL0113A .17 CC5578 .17 CC5588 .17 CC5598 .17 CC5508 .17 CC5568 .17 CC5578 .17 TLR 123 3.00 3mm LED SGS .20 TLG123 2.50 3mm LED SGS .20 TLY123 .17 LED WATER 10 Z0160 1.00 RECT. LEC. RED .22 Z0162 1.00 RECT LEO BRN .23 Z0164 1.00 RECT. LED YEL .24	DIODES IN4002 .10 IN4004 .12 IN4007 .14 IN4148 .08 IN5404 .30 IN5408 .36 OAA7 .45 OA90 .30 OA91 .30	OA95 .30 OA202 1.30 BA102 1.10 BAW62 .25 BYU96E .85 BY255 1.10 1300V 3A .10 P600G GAMP .60 IN3492 2.80 25A STUD 2.80 IN3492 R 2.80 25A STUD BRIDGES AC154 .40 1.5 AMP .40 BRW04 .50 1.5 AMP .50 DB04 1.20 SB204 1.20 2 AMP 1.10 RS 204 1.20 INLINE 1.20 MEL12 .95 MFE131 2.40 M1001 3.50 MJ15003 6.50 MJ15004 6.50 MJ2500 2.95 MJ2955 1.40 MJ3000 6.00 MJ4032 8.50 MJ4035 8.50 MJ413 6.50 MJA02 6.50 MJ802 6.80 MJE 13005 2.95 MJE 13007 2.95 MJE 2955T 1.50 MJE 2955 2.50 MJE 3055T 1.45 MJE 3055 3.00 MJE 340 2.20 MJE 350 2.20 MJE 521 1.80 MJE 700 1.40 MJE 800 1.40 MPS A05 .60 MPS A06 .60 MPSA12 .60 MPSA13 .80 MPSA14 .80 MPSA42 .75 MPSA56 .80 MPSA64 1.20 MPSA70 .60 MPSA92 .80 MPSA93 .80 MPP102 .30 MRF105 65 MPSL01 .65 MRF237 5.90 MRF 245 53.00 MRF454 52.00 MRF475 7.70 MRF901 3.75 TI110 1.40 TI112 1.40 TI115 1.40 TI117 1.40 TI120 1.40 TI137 1.40 TI1995 1.50 TI13055 1.50 TI29A .65 TI29C .65 TI30C .65 TI31 70 TI31C 70 TI32 .75 TI32C .75 TI34A 1.80 TI34A 1.80 TI41 1.30 TI41C 1.35 TI42A 1.30 TI42C 1.35 2N1304 3.50 2N1306 4.80 2N1309 4.95 2N1613 1.00 2N2211 7.50 2N2219A .85 2N2221A 1.00 2N2222A .85 2N2369A .85 2N2484 .80 2N2646 .95 2N2647 2.50 2N2894 1.00 2N2904A .95 2N2905A .95 2N2906A .95 2N2907A .95 2N301 4.00 2N3019 1.00 2N3053 .90 2N3054 1.90 2N3055 .95 2N3107 1.50	BF198 40 BF199 40 BF337 1.20 BF458 1.05 BF459 1.95 BF469 1.15 BF470 1.15 BF494 .60 BFY50 1.00 BFY90 1.50 BU126 2.50 BU208A 4.50 BU326A 3.50 BU406D 2.95 BU407A 2.50 BU426 3.50 BUX10 14.95 BUX80 4.25 BUY185 9.50 BUY48 4.95 BUY69A 8.50 MEL12 .95 MFE131 2.40 M1001 3.50 MJ15003 6.50 MJ15004 6.50 MJ2500 2.95 MJ2955 1.40 MJ3000 6.00 MJ4032 8.50 MJ4035 8.50 MJ413 6.50 MJA02 6.50 MJ802 6.80 MJE 13005 2.95 MJE 13007 2.95 MJE 2955T 1.50 MJE 2955 2.50 MJE 3055T 1.45 MJE 3055 3.00 MJE 340 2.20 MJE 350 2.20 MJE 521 1.80 MJE 700 1.40 MJE 800 1.40 MPS A05 .60 MPS A06 .60 MPSA12 .60 MPSA13 .80 MPSA14 .80 MPSA42 .75 MPSA56 .80 MPSA64 1.20 MPSA70 .60 MPSA92 .80 MPSA93 .80 MPP102 .30 MRF105 65 MPSL01 .65 MRF237 5.90 MRF 245 53.00 MRF454 52.00 MRF475 7.70 MRF901 3.75 TI110 1.40 TI112 1.40 TI115 1.40 TI117 1.40 TI120 1.40 TI137 1.40 TI1995 1.50 TI13055 1.50 TI29A .65 TI29C .65 TI30C .65 TI31 70 TI31C 70 TI32 .75 TI32C .75 TI34A 1.80 TI34A 1.80 TI41 1.30 TI41C 1.35 TI42A 1.30 TI42C 1.35 2N1304 3.50 2N1306 4.80 2N1309 4.95 2N1613 1.00 2N2211 7.50 2N2219A .85 2N2221A 1.00 2N2222A .85 2N2369A .85 2N2484 .80 2N2646 .95 2N2647 2.50 2N2894 1.00 2N2904A .95 2N2905A .95 2N2906A .95 2N2907A .95 2N301 4.00 2N3019 1.00 2N3053 .90 2N3054 1.90 2N3055 .95 2N3107 1.50	2N3110 .95 2N3440 1.50 2N3441 2.90 2N3442 3.40 2N3563 .30 2N3565 .30 2N3566 .30 2N3567 .30 2N3568 .30 2N3569 .30 2N3638 .30 2N3639 .30 2N3640 .30 2N3641 .30 2N3642 .30 2N3643 .30 2N3644 .30 2N3645 .30 2N3646 .30 2N3647 .30 2N3704 .60 2N3771 5.50 2N3772 5.70 2N3773 5.90 2N3819 1.10 2N3866 2.20 2N3904 5.50 2N3906 .50 2N4030 1.40 2N4032 1.95 2N4033 1.95 2N4036 1.50 2N4121 1.00 2N4124 1.00 2N4233 4.50 2N4236 1.90 2N4237 1.90 2N4249 .35 2N4250 .35 2N4258 .40 2N4355 .45 2N4356 .45 2N4401 .30 2N4402 .30 2N4403 .30 2N4427 2.50 2N5088 .90 2N5089 .90 2N5179 1.50 2N5190 1.95 2N5191 1.80 2N5192 1.80 2N5193 1.80 2N5195 1.80 2N5210 1.20 2N5245 1.20 2N5303 6.50 2N5401 .95 2N5457 .95 2N5458 .85 2N5459 .95 2N5461 .90 2N5485 .90 2N5486 .90 2N5590 16.50 2N5591 18.50 2N5770 .30 2N5777 1.50 2N5830 .30 2N5831 .30 2N5873 1.40 2N5874 1.70 2N5944 15.50 2N5944 15.50 2N5946 19.50 2N5961 1.20 2N6027 .95 2N6028 1.00 2N6080 18.50 2N6083 21.90 2N6084 32.00 2N6122 1.00 2N6123 1.00 2N6124 1.00 2N6125 1.20 2N6126 1.50 2N6129 1.50 2N6130 1.50 2N6131 1.50 2N6133 1.50 2N697 1.00 2N918 1.00 Z5C106 1.50 Z5D325 2.95 Z5D350A 5.00 Z5D353 5.95 Z5J49 5.90 Z5K134 5.90 SCR1 .85 C1030 .80 C106D .90 C122D 1.65 C122E 1.65 C220D 6.50	TRIACS SC141D 1.45 SC1460 2.50 SC151D 2.85 SC260D 7.95
---	---	---	---	---	---	---	--	---



SPECIALS
MONTH OF FEBRUARY ONLY

TOP BRAND MITSUBISHI MONITORS

GREEN NV1290 x \$165

AMBER NV1290 x \$175



D1122
only \$3950
NEW MRF454 DATA CASSETTE PLAYER

MITSUBISHI DISK DRIVES



M4851 500K 40 track D.D. only \$215
M4853 1M 80 track D.D. only \$255
M4854 1.6M 77 track D.D. only \$339
M4855 2 meg only \$384

Mitsubishi 8" drives

M2896 Slimline \$570
M2894 Standard \$545

* All prices include sales tax.

HY SPEED CMOS DATA BOOK

\$5.00
incl. post & packed to anywhere in Australia.

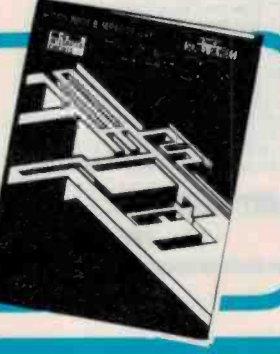

MAIL ORDER HOT LINE (03) 671312



POSTAGE RATES

\$1-\$9.99	\$1.50
\$10-\$24.99	\$2.00
\$25-\$49.99	\$3.00
\$50-\$99.99	\$3.50
\$100-\$199	\$5.00
\$200-\$499	7.50
\$500 plus	\$10.00

ALL ELECTRONIC COMPONENTS

Division of DOTHAIN Pty. Ltd.

118-122 LONSDALE STREET, MELBOURNE, VIC. 3000. TEL: 662-3506

TALK ABOUT A HUGE RANGE OF KITS!

STEREO UNITS

- S1 ETI 484 Compressor Expander
- S2 ETI 482 50 watt per channel Amplifier
- S3 ETI 482A Preamp Board
- S4 ETI 482B Tone Control Board
- S5 ETI 485 Graphic Equalizer
- S6 ETI 480 50 watt Amplifier
- S7 ETI 480 100 watt Amplifier
- S9 ETI 443 Expander Compressor
- S10 ETI 444 Five watt stereo
- S12 ETI 438 Audio Level Meter
- S13 ETI 440 25 watt Stereo Amplifier including metalwork.
- S18 ETI 426 Rumble Filter
- S19 ETI 429 Simple Stereo Amplifier
- S21 ETI 417 Over Load Distortion Monitor
- S35 ETI 470 60 watt audio amplifier module
- S36 ETI 400K Series 80 watt stereo amplifier
- S37 ETI 451 Hum Filter for Hi-Fi systems
- S38 E.A. Stereo Infrared Remote Switch
- S39 ETI 455 Stereo Loudspeaker Protector
- S40 E.A. Super-Bass Filter
- S42 E.A. Stylus Timer
- S43 ETI 3000 Series Amplifier 25 wch
- S44 ETI 477 Mosfet power amp module inc. brackets
- S45 ETI 472 Scratch/Rumble Filter
- S46 ETI 458 VU Level Meter
- S47 ETI 479 Bridging Adaptor
- S48 ETI 5000 Series Power Amplifier
- S49 ETI 494 Loudspeaker Protector
- S50 EA Infrared TV Sound Control
- S51 HE 121 Scratch & Hiss Filter
- S52 EA 100W Sub Woofer Module
- S53 EA Stereo Simulator
- S54 EA Headphone Amp.
- S55 ETI 412 Peak Display

STAGE

- S11 ETI 592 Light Show Controller (3 ch.) (1000 wch)
- S12 ETI 593 Colour Sequencer (for use with ETI 592)
- S13 ETI 551 Light Chaser 3 ch. 1000 wch
- S14 E.A. Light Chaser 3 channel
- S15 E.A. Twin Tremolo for Organs/Stage Amps
- S17 ETI 499 150 w Mosfet P.A. Module
- S18 ETI 498/499 150 w Public Address Amplifier
- S19 E.A. Musicoolor IV
- S110 EA Musicoolor III

PRE-AMPLIFIER AND MIXERS

- P1 ETI 445 Stereo Pre-amplifier
- P2 ETI 449 Balance Mic Pre-amplifier
- P6 ETI 419 Mixer Pre-amplifier — 4 ch. Mixer Pre-amplifier — 2 ch.
- P10 E.A. Playmaster 145 Mixer
- P11 ETI 446 Audio Limiter
- P12 ETI 471 High Performance Stereo Pre-amplifier — less F/P & Backing Plate
- P13 ETI 473 Moving Coil Cartridge Pre-Amp
- P14 ETI 474 High to low Impedance Interface
- P15 ETI 467 4 Input Guitar/Mic. Pre-amp suits ETI 466 — includes power supply
- P16 E.A. Moving Coil Pre-Amplifier (Battery)
- P17 E.A. Moving Coil Pre-Amplifier (Plug pack)
- P18 ETI 478 MM Moving Magnet Pre-amp (Series 5000)
- P19 ETI 478MC Moving Coil Pre-amp (Series 5000)
- P20 ETI 478 Series 5000 Pre-Amplifier
- P21 E.A. Vocal Cancellor
- P22 ETI 416 Balanced Pre-amplifier
- P23 HE 112 Micromixer
- P24 EA Effects Unit
- P25 EA Stereo Simulator

GUITAR UNITS

- G1 ETI 447 Audio Phaser
- G2 ETI 413 2-100W Bridge Amp.
- G5 ETI 413 100 watt Guitar Amplifier
- G14 ETI 452 Guitar Practice Amplifier
- G15 ETI 466 300 watt Amp module
- G16 ETI 454 Fuzz Sustain
- G17 HE 102 Guitar Phaser
- G18 ETI 450A Bucket Brigade
- G19 ETI 450B Mixer for above
- G20 E.A. guitar Pre-amplifier
- G21 Sonics ME2 Sonics ME2 Wah Wah Pedal-less pedal

AUDIO TEST UNITS

- AT1 ETI 441 Audio Noise Generator
- AT2 ETI 128 Audio Millivolt Meter
- AT4 ETI 102 Audio Signal Generator
- AT5 E.A. A.F. Tone Burst Generator
- AT7 ETI 137 Audio Oscillator
- AT9 HE 105 Bench Amplifier
- AT10 E.A. Audio Test Unit
- AT11 E.A. Function Generator
- AT12 ETI 464 Audio Test Unit

TIMERS

- T1 ETI 650 STAC Timer
- T2 ETI 564 Digital Wall Clock
- T3 E.A. Universal Timer and Stopwatch
- T4 ETI 540 Universal Timer
- T5 ETI 265 Power Down

- T6 EA 4 Digit L.C.D. Clock or Control Timer
- T7 EA Event Counter

COMMUNICATION EQUIPMENT

- CE1 ETI 711 Remote Control Transmitter Switch
- CE2 ETI 711R Remote Control Receiver
- CE3 ETI 711D Remote Control Decoder
- CE4 ETI 711B Single Control
- CE5 Double Control
- CE6 ETI 711P Power Supply
- CE7 ETI 707A 144 Mhz Converter
- CE8 ETI 707B 52 Mhz Converter
- CE9 ETI 708 Active Antenna
- CE11 ETI 780 Novice Transmitter
- CE12 ETI 703 Antenna Matching Unit
- CE29 E.A. Short Wave Converter for 27 Mhz
- CE31 E.A. 27 Mhz Pre-amp
- CE32 E.A. 10-30 Mhz Pre-amp
- CE33 ETI 718 Shortwave Radio
- CE34 ETI 490 Audio Compressor
- CE35 ETI 721 Aircraft Band Converter (less XTALS)
- CE36 ETI 726 or 10 metre Power Amp
- CE37 ETI 475 Wide Band A.M. Tuner
- CE38 E.A. Masthead Pre-amplifier
- CE39 ETI 731 R.T.T.Y. Modulator
- CE40 ETI 729 UHF TV Masthead Preamp.
- CE41 ETI 735 UHF to VHF TV Converter
- CE42 HE 104 AM Tuner
- CE43 HE 106 Radio Microphone
- CE44 E.A. R.T.T.Y. Demodulator
- CE45 E.A. Voice Operator Relay
- CE46 ETI 733 RTTY Converter for Microbee
- CE47 ETI 1517 Video Distribution Amp.
- CE48 EA Video Enhancer
- CE49 Wideband Amp.
- CE50 ETI 1518 Video Enhancer
- CE51 EA VCR Sound Processor

METAL DETECTORS

- MD1 ETI 549 Induction Balance Metal Detector
- MD2 ETI 561 Metal Locator
- MD3 ETI 1500 Discriminating Metal Locator (undrilled case)
- MD4 ETI 1500 Discriminating Metal Locator (pre-drilled case)
- MD5 ETI 562 Geiger Counter with ZP 1310 Tube
- MD6 ETI 566 Pipe and Cable Locator
- MD7 E.A. Prospector Metal Locator including headphones

TEST EQUIPMENT

- TE2 ETI 133 Phase Meter
- TE4 ETI 129 R.F. Signal Generator
- TE6 ETI 706 Marker Generator
- TE8 ETI 122 Logic Tester
- TE9 ETI 124 Tone Burst Generator
- TE11 ETI 116 Impedance Meter
- TE12 ETI 533 Digital Display
- TE15 ETI 704 Cross-Hatch Dot Generator
- TE16 ETI 120 Logic Probe
- TE17 ETI 121 Logic Pulsar
- TE34 ETI 487 Real Time Audio Analyser
- TE35 ETI 483 Sound Level Meter
- TE36 ETI 489 Real Time Audio Analyser
- TE37 ETI 717 Cross Hatch Generators
- TE38 E.A. 3 Mhz Frequency Counter
- TE42 E.A. Transistor Tester incl. BiPolar & F.E.T.S.
- TE43 ETI 591 Up Down Pre-settable Counter
- TE44 ETI 550 Digital dial (less case) includes ETI 591
- TE45 ETI 144 Expanded Scale R.M.S. Voltmeter
- TE46 ETI 148 Versatile Logic Probe
- TE47 ETI 724 Microwave Oven Leak Detector
- TE48 ETI 150 Simple Analog Frequency Meter
- TE49 ETI 151 Linear Scale Ohm Meter
- TE50 ETI 152 Linear Scale Capacitance Meter
- TE51 E.A. Digital Capacitance Meter
- TE52 ETI 589 Digital Temp. Meter
- TE53 E.A. T.V. C.R.D. Adaptor
- TE54 E.A. XTAL Locked Pattern Generator
- TE55 E.A. Decade Resistance Sub Box
- TE56 E.A. Capacitance Sub Box
- TE57 E.A. Decade Capacitance Sub Box
- TE58 E.A. Tantalum Capacitance Sub Box
- TE59 ETI 140 1 Ghz Frequency Meter/Timer
- TE60 ETI 572 PH Meter
- TE61 ETI 135 Panel Meter
- TE62 E.A. Modulated Signal Injector
- TE63 HE 103 Transistor Tester
- TE64 HE 111 Ohm meter
- TE65 ETI 157 Crystal Marker
- TE66 ETI 161 Digital Panel Meter
- TE67 ETI 255 Analog Thermometer
- TE68 EA Transistor Tester
- TE69 ETI 175 20 Mhz Dig. Frequency Meter (Hand held)
- TE70 ETI 166 Function Pulse Generator
- TE71 X-tal Locked Pattern Generator

MODEL TRAIN UNITS (see also "SOUND EFFECTS")

- M11 ETI 541 Model Train Control
- M12 E.A. 1974 Model Train Control
- M16 E.A. 1978 Train Control less Front Panel

- 1978 Train Control with Front Panel

SOUND EFFECTS

- SE1 E.A. Sound Effects Generator*
- SE2 E.A. Musical Tone Generator
- SE3 E.A. Cylon Voice
- SE4 E.A. Steam Whistle
- SE5 ETI 607 Sound Effects
- SE6 E.A. 492 Audio Sound Bender
- SE7 E.A. Electronic Sea Shell Sound Effects
- SE8 ETI 469A Percussion Synthesiser
- SE9 ETI 469B Sequencer for Synthesiser
- SE10 EA Effects Unit

* set as for Steam Train and Prop Plane noise

VOLTAGE/CURRENT CONTROLS

- V1 ETI 481 12 volt to $\pm 40v$ D.C. 100 watt Inverter
- V2 ETI 525 Drill Speed Controller
- V6 E.A. 1976 Speed Control
- V10 E.A. Zero-voltage switching heat controller
- V11 E.A. Inverter 12v D.C. Input 230v 50 Hz 300VA output not incl. switch 35 amp.
- V12 ETI 1505 Fluorescent Light Inverter
- V13 EA Electric Fence
- V14 ETI 1506 Xenon Push Bike Flasher
- V15 ETI 1509 DC-DC inverter
- V16 ETI 1512 Electric Fence Tester
- V17 EA Fluro Light Starter
- V18 ETI 1524 Electronic Mouse Trap

WARNING SYSTEMS

- WS1 ETI 583 Gas Alarm
- WS3 ETI 528 Home Burglar Alarm
- WS4 ETI 702 Radar Intruder Alarm
- WS7 ETI 313 Car Alarm
- WS12 ETI 582 House Alarm
- WS14 E.A. 1976 Car Alarm
- WS15 E.A. 10 Ghz Radar Alarm
- WS16 E.A. Light Beam Relay
- WS17 ETI 247 Soil Moisture Indicator
- WS18 ETI 250 Simple House Alarm
- WS19 ETI 570 Infrared 'Trip' Relay
- WS20 ETI 585 T&R Ultrasonic Switch
- WS21 ETI 330 Car Alarm
- WS22 ETI 322 Over Rev Car Alarm incl. case
- WS24 ETI 1506 Xenon Bike Flasher
- WS25 ETI 340 Car Alarm
- WS26 EA Deluxe Car Alarm
- WS27 EA Ultrasonic Movement Detector

PHOTOGRAPHIC

- PH1 ETI 586 Shutter Speed Timer
- PH3 ETI 514B Sound Light Flash Trigger
- PH4 ETI 532 Photo Timer
- PH7 ETI 513 Tape Slide Synchronizer
- PH12 ETI Sync-a-Slide
- PH14 ETI 558 Mast Head Strobe
- PH15 ETI 553 Tape Slide Synchronizer
- PH16 E.A. Digital Photo Timer
- PH17 ETI 594 Development Timer
- PH18 ETI 568 Sound of light operated Flash Trigger including optional parts
- PH19 E.A. Sound Triggered Photoflash
- PH20 HE 109 Extra Flash Trigger
- PH21 E.A. Photographic Timer

POWER SUPPLIES

- PS1 ETI 132 Experimenters Power Supply
- PS2 ETI 581 Dual Power Supply
- PS3 ETI 712 CB Power Supply
- PS4 ETI 131 Power Supply
- PS6 ETI 105 Laboratory Power Supply
- PS7 ETI 111 VC Power Supply
- PS9 E.A. 1976 Regulated Power Supply
- PS11 E.A. C.B. Power Supply
- PS12 ETI 142 Power Supply 0-30 V 0-15 A (fully protected)
- PS13 ETI 472 Power Supply
- PS14 E.A. Power Supply for Dream 6800
- PS15 ETI 577 Dual 12V supply
- PS16 E.A. Power Saver
- PS17 ETI 480 PS Power Supply for ETI 480 (100 watt Amp.)
- PS18 E.A. Bench Mate Utility Amplifier/Power Supply
- PS19 HE 108 Power Supply
- PS20 ETI 163 0-40 V, 0-5 A
- PS21 EA Dual Tracking Power-Supply

COMPUTER AND DIGITAL UNITS

- C1 ETI 633 Video Synchronizer
- C2 ETI 632M Part 1 Memory Board V.D.U.*
- C3 ETI 632P Part 1 Power Supply V.D.U.*
- C4 ETI 632A Part 2 Control Logic V.D.U.*
- C5 ETI 632B Part 2 Control Logic V.D.U.*
- C6 ETI 632C Part 2 Character Generator V.D.U.*
- C8 ETI 632 U.A.R.T. Board*
- C9 ETI 631-2 Keyboard Encoder*
- C10 ETI 631 A/Sch. Keyboard Encoder
- C11 ETI 638 Eprom Programmer
- C15 ETI 637 Cuts Cassette Interface
- C16 ETI 651 Binary to Hex Number Converter

- C17 ETI 730 Getting Going on Radio Tele Type
- C22 ETI 660 Basic Computer
- C23 ETI 660 Basic Computer incl. colour option on board expandable memory, RF modulator, case and power supply
- C24 ETI 760 Video RF Modulator
- C25 E.A. Eprom Programmer
- C26 ETI 668 Microbee Eprom Programmer
- C27 ETI 733 RTTY Computer Decoder
- C28 EA Video Amp for Computers
- C29 ETI 649 Microbee Light Pen
- C30 ETI 675 Microbee Serial — Parallel Interface
- C31 ETI 688 Programmer for Fusible — Link Bipolar Proms
- C32 ETI 676 RS232 for Microbee

* all V.D.U. projects priced less connectors

BIO FEEDBACK

- BF1 ETI 546 G.S.R. Monitor (less probes)
- BF2 ETI 544 Heart Rate Monitor
- BF3 ETI 576 Electromyogram

AUTOMOTIVE UNITS

- A1 ETI 317 Rev. Monitor
- A2 ETI 081 Tachometer
- A3 ETI 316 Transistor Assisted Ignition
- A4 ETI 240 High Power Emergency Flasher
- A6 ETI 312 Electronic Ignition System
- A7 ETI 301 Vari-Wiper
- A14 E.A. Dwell Meter
- A15 E.A. Variwiper
- A16 E.A. Tacho for Tune-ups
- A17 E.A. Ignition Analyser and Tachometer
- A18 E.A. Strobe Adaptor for Ignition Analyser
- A19 E.A. 1975 C.D.I. Capacitor discharge Ignition
- A22 ETI 318 Digital Car Tachometer
- A23 ETI 319A Variwiper Mx. 2 (no dynamic Braking)
- A24 ETI 319B Variwiper Mx. 2 (for dynamic braking)
- A25 ETI 555 Light Activated Tacho
- A26 ETI 320 Battery Condition Indicator
- A27 E.A. Transistor Assisted Ignition
- A28 ETI 324 Twin Range Tacho less case
- A29 ETI 328 Led Oil Temp Meter less V.D.O. probe
- A30 ETI 321 Auto Fuel Level Alarm
- A31 ETI 332 Stethoscope
- A32 ETI 325 Auto Probe Tests Vehicle Electricals
- A33 ETI 333 Reversing Alarm
- A34 E.A. Low fuel indicator
- A35 ETI 326 Led Expanded Voltmeter
- A36 ETI 329 Ammeter (expanded scale)
- A37 ETI 327 Turn and Hazard Indicator
- A38 ETI 325 Expanded Scale Voltmeter
- A39 EA Optoelectronic Ignition
- A40 ETI 335 Wiper Controller
- A41 EA Ignition Killer for Cars
- A42 EA L.C.D. Car Clock
- A43 EA Cruise Control
- A44 ETI 337 Automatic Car Aerial Controller

ELECTRONIC GAMES

- EG1 ETI 043 Heads and Tails
- EG2 ETI 068 L.E.D. Dice Circuit
- EG3 E.A. Electronic Roulette Wheel
- EG4 ETI 557 Reaction Timer
- EG5 ETI 814 Dinky Die
- EG6 E.A. Selectalot
- EG7 HE 107 Electronic Dice
- EG8 E.A. Photon Torpedo
- EG9 HE 123 Alien Invaders
- EG10 EA Roulette Wheel

MISCELLANEOUS KITS

- M1 ETI 604 Accentuated Beat Metronome
- M4 ETI 547 Telephone Bell Extender
- M5 ETI 602 Mini Organ (less case)
- M7 ETI 044 Two Tone Doorbell
- M10 ETI 539 Touch Switch
- M25 E.A. Digital Metronome
- M37 ETI 249 Combination lock (less lock)
- M39 E.A. Electronic Combination lock (including lock)
- M46 E.A. Power Saver for induction motors
- M48 E.A. Lissajous Pattern Generator
- M53 ETI Soil Moisture Alarm
- M54 E.A. Bench Mate Utility Amplifier/Power Supply
- M55 E.A. Pools/Lotto Selector
- M56 ETI 256 Humidity Meter
- M57 ETI 257 Universal Relay Driver Board
- M58 E.A. Simple Metronome
- M59 ETI 1501 Neg. Ion Generator
- M60 ETI 1516 Sure Start for Model Aeroplanes
- M61 ETI 412 Peak Level Display
- M62 ETI 1515 Motor Speed Controller
- M63 ETI 1520 Wideband Amplifier
- M64 EA Phone Minder
- M65 EA Motorcycle Intercom
- M66 EA Simple L.C.D. Clock
- M67 EA Ultrasonic Rule

Note: We do not stock sub-standard poor quality components.

PLUS MANY, MANY MORE KITS WHICH WE CANNOT LIST HERE!!!
JUST CONTACT US FOR PRICE & AVAILABILITY.

TRADE AND RESELLER ENQUIRIES WELCOME.

COMPUTERISED CIRCUIT ANALYSIS

Designing amplifier circuits? This article shows how to design programs to take the sweat and guesswork out of the operation.

Lance Wilson
Jon Fairall

MOST READERS of this magazine will, sooner or later, find themselves in a position where they have to design basic amplifier circuits. This need not be a tedious and time-consuming task if you develop some of the ideas presented in this article. We have included a demonstration program for the sake of interest, but the object of this exercise is to show you how to go about the problem of designing with a computer. You can write your own program to suit your own computer and your own design.

The fundamental circuit for a Class A amplifier is given in Figure 1. The first step in analysing a transistor circuit is to establish the biasing, since it is this that sets up the effective gain of the amplifier. For the circuit in Figure 1 the first step is to establish the base voltage, V_b . A standard but simplified equation which allows a quick solution is:

$$V_b = \frac{R_{b2} \times V_{cc}}{R_{b1} + R_{b2}}$$

From this we can determine V_e very quickly if we assume that there will be a drop of about 0.6 V across the base-emitter junction of the transistor:

$$V_e = V_b - 0.6$$

Figure 1. General form of the Class A voltage amp.

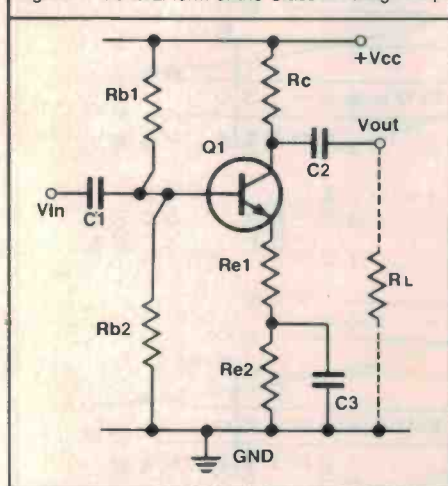

We now have access to the current flowing in the emitter resistor from Ohm's law, since we know the voltage across the resistor and its value:

$$I_e = \frac{V_e}{R_e}$$

where $R_e = R_{e1} + R_{e2}$.

Since we also know that the emitter current must be more or less the same as the collector current we can also work out the collector voltage:

$$V_c = V_{cc} - R_c I_c$$

AC response

With this series of simple steps we have worked out all the voltages around the transistor plus the current flowing between the collector and the emitter. We are now in a position to begin an examination of the circuit's response to an input signal, i.e. its ac response.

The gain of an amplifier is given by:

$$A_v = \frac{\text{collector load}}{\text{emitter load}}$$

Bear in mind that these values apply to ac conditions only. The collector load includes all the resistances that tie the collector to either the ground or supply rails. (Supply is ac-short to ground through the power supply.) It includes at least the collector resistor R_c , the load resistance R_L and the collector-emitter leakage resistance. This latter is usually so high that it can be ignored in low frequency, small signal applications.

The emitter load, likewise, includes all the resistances between the emitter of the transistor and either rail. In practice this will mean the unbypassed emitter resistor R_{e1} , but not R_{e2} . Remember we are talking about ac and assuming that all the capacitors are short circuits, so R_{e2} is effectively shorted. It also includes the base-emitter resistance, r_e , which is given by $30/I_c$.

The result of this is that we can establish a gain equation for the circuit of Figure 1:

$$A_v = \frac{R_c}{r_e + R_{e1}}$$

Figure 2. Plotting the ac and dc load lines.

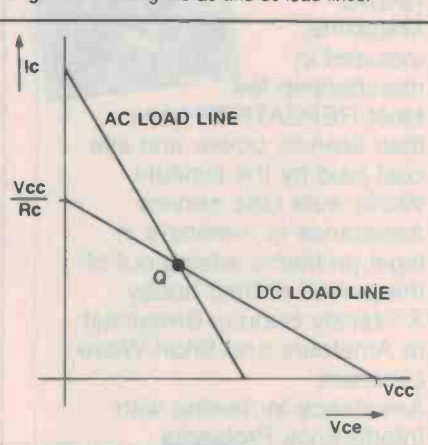

Obviously, different configurations will have different equations, but the principle remains the same, so you can work out the relevant equation for your particular application.

So far, we have sufficient information to generate a program that will predict certain elements of the performance of an amplifier given the circuit. If you input the values of the resistors the program should come back at you with the gain. If you go to a textbook you should be able to extract equations to give you input and output resistance as well.

The question not answered, and the one we would like to know, is whether the combination of resistors we have chosen is an optimum. The classic method of doing this is with the load line.

Load Lines

Load line analysis involves drawing a pair of straight lines corresponding to the ac and dc loads on the transistor. It is actually a graph of I_c and against V_{ce} . The load line is thus all the possible combinations of I_c and V_{ce} that can exist at the collector of the particular amplifier under consideration.

We can determine the dc line quite easily (see Figure 2). When no current flows i.e. $I_c=0$, then $V_{ce}=V_{cc}$. This defines the bottom point of the line; i.e. the intersection with the horizontal axis. At the other end of the line, when V_{ce} is at a minimum, I_c is

WIRELESS INSTITUTE OF AUSTRALIA

FOUNDED 1910

The W.I.A. represents the Radio Amateur at Local, National and International level and offers following services:



- ★ Monthly "AMATEUR RADIO" Magazine, included in membership fee.
- ★ Most REPEATERS have their licence, power and site cost paid by the institute.
- ★ World wide QSL-service.
- ★ Assistance to members in legal problems arising out of the pursuit of their hobby.
- ★ A Weekly Sunday Broadcast to Amateurs and Short Wave Listeners.
- ★ Assistance in dealing with Interference Problems (TVI-RFI etc.)
- ★ Novice and full call courses.
- ★ Trial Novice and AOCB theory exam papers.
- ★ Advice on Radio Mast approvals
- ★ The ONLY representation of the RADIO AMATEUR in legislative matters.



Join the 8,600 Amateur members in the W.I.A. by forwarding this coupon to:
W.I.A. P.O. BOX 300,

CAULFIELD SOUTH, VIC. 3162

Please forward a membership application form and further details to:

Mr, Mrs, Miss, Ms

Address

Callsign

Postcode

TECHNIQUES

determined by the value of the resistors through which it flows (V_{ce} is assumed to be zero). The dc load line is just a straight line between these two points.

The operating point, Q, at which the amplifier is biased, must lie somewhere on this line. The ac line intersects the dc line at this point. It is drawn with slope equal to the inverse of the ac collector load.

unloaded amplifier this will just be R_x , with the result that the ac slope will be the same as the dc slope. However, when the amplifier is loaded the slope of the line will tend to increase as the total collector resistance decreases.

As with the dc load line, the ac line determines the combination of values of I_c and V_{ce} that can exist in the amplifier with a

The plot quickens. Screen dumps of load lines plotted by the program over the page. The beauty of the technique is its ability to show the results of any variation quite quickly.

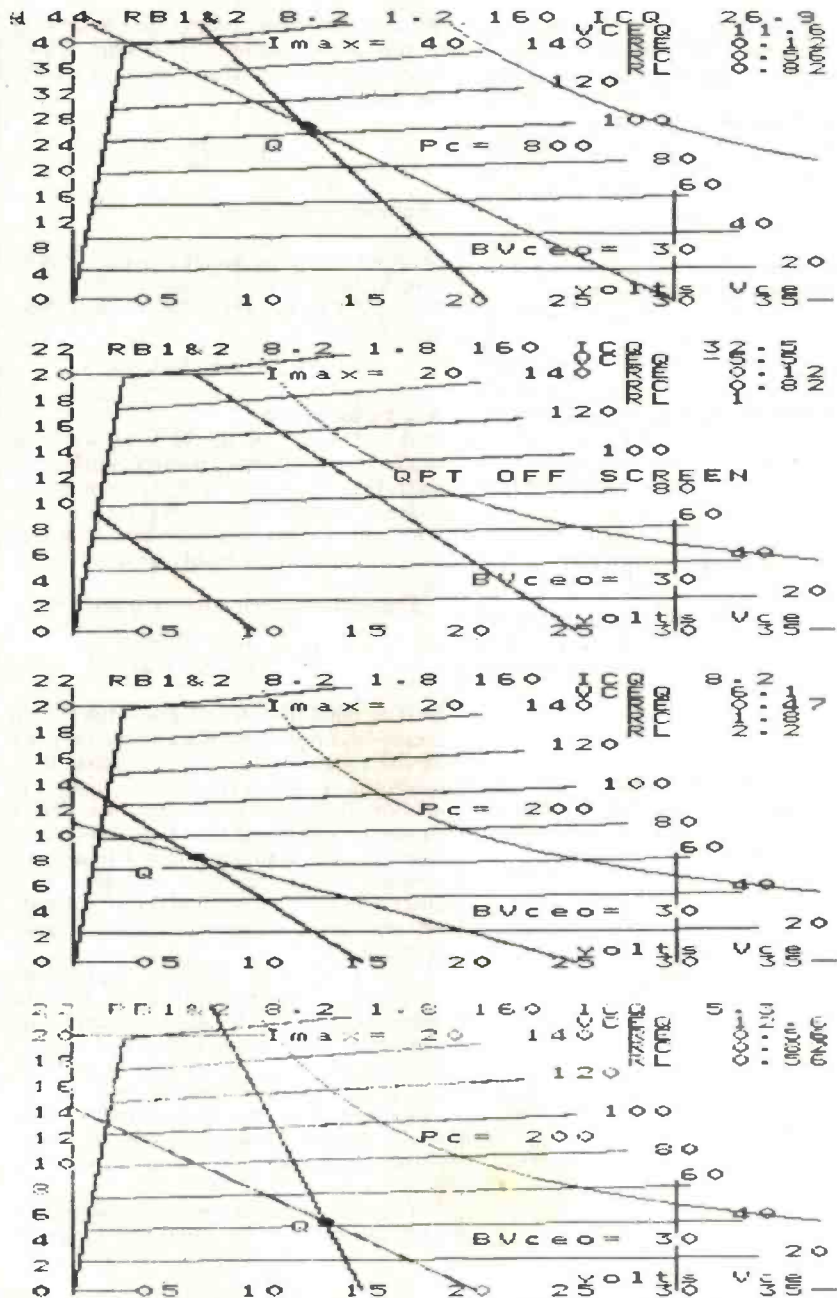

COMPUTER BOARDS



NEW PRODUCT!

EXCALIBUR

EXCALIBUR IS ALIVE AND WELL, KITS NOW AVAILABLE!

This stunning design with excellent choice, basic in ROM and a host of features is now available as a Kit.

FEATURES:

- Z80 CPU, 3.5 MHz, 64K RAM, 16K ROM.
- Direct video output, RF output and RGB.
- QWERTY Keyboard.
- Cassette Interface built in.
- Serial-RS232C, Parallel-8 bit centronics.
- Colour 18 foreground and 8 background colours.
- 24 lines by 80 characters 7 x 12 dot matrix (monitor required).

Cat. \$595



THE AMPRO LITTLE BOARD

★ ASSEMBLED AND TESTED ★

FEATURING:

- 4 MHz Z80 CPU!
- 64K Dynamic RAM!
- Double Density (5 1/4 inch) Floppy controller.
- Centronics style parallel printer port.
- Uses +5V DC at 75A and +12V DC at 50mA.
- Two RS232C serial ports.
- Same size as a mini floppy (only 5 1/4 x 7 1/4 inches).
- 2732 Boot Eprom.
- 110 Page Manual.

*** FREE CP/M 2.2II (\$195 VALUE) ***

A FREE 5 1/4 inch CP/M 2.2 Diskette is included with each Kit. ASSEMBLED AND TESTED ONLY including tax \$516

Cat. tax exempt \$430



BIG BOARD II OVER 1,000 SOLD!

Jim Ferguson, designer of the "Big Board" distributed by Digital Research Computers, produced this stunning computer "Big Board II".

FEATURES:

- 4 MHz Z80 CPU AND PERIPHERALS CHIPS: The Ferguson computer runs at 4MHz. Its monitor code is lean, uses Mode 2 interrupts, and makes good use of the Z80-A DMA chip.
- 64K RAM + 4K STATIC CRT RAM - 24K (EPROM OR STATIC RAM): "Big Board II" has the three memory banks: the first memory bank has eight 4164 RAM's that provide 60K of user space and 4K of monitor space. The second memory bank has two 2K and 8 SRAM's for the memory-mapped CRT display and space for six 2732's or 2K x 8 static RAM's, or pin compatible (EPROM's), the third memory bank is for RAM or ROM added to the board via the STD bus. Whether bought as a bare board, a full Kit, or assembled and tested, it comes with a 450NS2732A EPROM containing the monitor.
- MULTIPLE DENSITY CONTROLLER FOR SS/DS FLOPPY DISKS: The "Big Board II" computer has a multiple density disk controller; it can use 1793 or 8877 controller chips. The board has two connectors for disk signal with 34 pins for 5 1/4" drives, the other with 50 pins for 8" drives.
- VASTLY IMPROVED CRT DISPLAY: The "Big Board II" computer uses a 6845S-CRT controller and 8002 Video Attributes controller to produce a display that will rival the display of quality terminals. Characters are formed by a 5 x 7 dot matrix on 15.75 KHz monitors and a 7 x 9 dot matrix on 15.75 KHz monitors. The display is user-programmable with the default display 24 lines of 80 characters.
- STD BUS CONNECTOR: "Big Board II" brings its bus signals to a convenient place on the PC board where users can solder a STD socket, bus cards can be plugged directly into it, and it can as well be connected by bus cable to industry standard card cages.
- A Z80-A S10/D = TWO ASYNCHRONOUS SYNCHRONOUS SERIAL PORTS.
- TWO Z80-A CTC's = EIGHT PROGRAMMABLE COUNTERS/TIMERS: The "Big Board II" has two Z80-A CTC's. One is used to clock data into and out of the Z80-A CTC's. One is used to clock data into and out of the Z80-A S10/D, while the other is for system and application use.
- PROM PROGRAMMING CIRCUITRY AND SOFTWARE: The "Big Board" computer has circuitry and drivers for programming 2716s, 2732A's, or pin-compatible (EPROM's). (Software \$25 extra).
- CP/M CAPABILITY: CP/M with Russel Smith's CBIOS for the "Big Board II" is available. (plus tax) \$230 The CBIO's 5" or 8" is avail. separately (plus tax) \$85

Cat. K41015 NOW \$595 (plus tax)

Less 10% for 3 or more! Assembled and Tested \$849 (plus tax)



THE LITTLE BIG BOARD

FEATURES:

- Z80A CPU (4 MHz)
- 65,536 bytes of RAM
- Two RS232C I/O ports.
- Battery back up realtime clock and calendar.
- Up to four, 8 inch or 8.25 inch double sided, double density or single density floppy disk drives.
- Full STD, Bus.
- Designed for C/P/M, MP/M and CP/NET systems.

Cat. (including tax) \$459



6809 "UNIBOARD" NEW SINGLE BOARD COMPUTER KIT!

Many software professionals feel that the 6809 features probably the most powerful instruction set available today on ANY 8 bit micro. Now, at last, all of that immense computing power is available at a truly unbelievably low price.

CHECK THE FEATURES!!!

- 64K RAM using 4116 RAM's.
- 6809E Motorola CPU.
- Double Density Floppy Disk Controller for either 5 1/4 or 8 inch drives. Uses WD1793.
- On board 80 x 24 video for a low cost console. Uses 2716 Char. Gen. Programmable Formats. Uses 6845 CRT Controller.
- ASCII Keyboard parallel input interface (6845).
- Serial I/O (6551) for RS232C or 20 MA loop.
- Centronics compatible parallel printer interface, (6522).
- Bus expansion interface with DMA Channel, (6844).
- Dual timer for real clock application.
- Powerful on board system monitor, (2732). Features commands such as Go To, Alter, Fill, Move, Display, or Test Memory, Also Read and Write Sectors, Boot Normal, Unknown, and General Flag.
- PC Board is double sided, plated through solder masked, 11 x 11 1/2 inch.
- Includes the powerful 3rd generation Motorola 6809 Processor. Ideal for colleges, O.E.M.'s, Industrial and scientific uses!

BLACK PC BOARD WITH PAL'S AND TWO EPROMS..... \$199

5 1/4 OR 8 INCH SOURCE DISKETTE ADD \$25

COMPLETE KIT, FULLY SOCKETED. ALL OPTIONS ARE STANDARD, NO EXTRAS TO BUY \$599

including tax

Please allow 4 weeks for delivery.

Cat. YOUR CHOICE OF POPULAR DISK OPERATING SYSTEMS.

FLEX 1m from TSC Cat. \$259

OS9 1m from Microwave Cat. \$349

(Please specify 5 1/4 or 8 inch.)

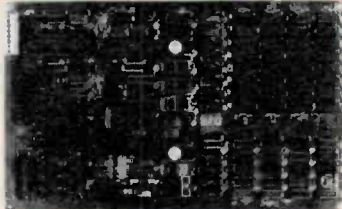

THE ORIGINAL BIG BOARD 1 COMPUTER KIT!

FEATURING:

- 64K RAM: Uses industry standard 4116 RAM's. All 64K is available to the user, our VIDEO and EPROM sections do not make holes in system RAM. Very special care was taken in the RAM array PC layout to eliminate potential noise and glitches.
- Z-80 CPU: Running at 2.5 MHz. Handles all 4116 RAM refresh and supports Mode 2 INTERRUPTS. Fully buffered and runs 5000 software.
- BASIC I/O: Consists of separate parallel port (Z80 PIO) for use with an ASCII encoded Keyboard for Input. Output would be on the 80 x 24 video Display.
- 24 x 80 CHARACTER VIDEO: With a crisp, flicker-free display that looks extremely sharp even on small monitors. Hardware scroll and full cursor control. Composite video or split video and sync. Character set is supplied on a 2716 style ROM, making customized fonts easy. Sync pulses can be any desired length or polarity. Video may be inverted or true. 5 x 7 Matrix, upper and lower case.
- FLOPPY DISK CONTROLLER: Uses WD 1771 controller chip with a TTL Data Separator for enhanced reliability. IBM 3740 compatible. Supports up to four 8 inch disk drives. Directly compatible with standard Shugart drives such as the SAB00 or SAB001. Drives can be configured for remote AC off/on. Runs CP/M 2.2.
- PFM 3.3 2K SYSTEM MONITOR: The real power of the Big Board lies in its PFM 3.3 on board monitor. PFM commands include: Dump Memory, Boot CP/M, Copy Examine, Fill Memory, Test Memory, Go To, Read and Write I/O ports, Disk Read/Drive Track, Sector and Search PFM occupies one of the four 2716 EPROM locations provided.
- FULLY SOCKETED.

Ideal for OEM, Industrial, Business, Scientific, Colleges etc.

Cat. K41001 including tax, \$379

OPTIONS AVAILABLE:

- CP/M 2.2 FOR BIG BOARD \$269
- TWO PORT PARALLEL I/O \$19
- SERIAL I/O \$35
- REAL TIME CLOCK \$15
- DOUBLE DENSITY ADAPTOR BOARD \$225
- BIOS DISK \$25



MITSUBISHI DISK DRIVES

M2896-63

Slimline 8" Disk Drive Double sided Density No AC Power required. 3ms track to track. 1.6 Mbytes unformatted, 77 track side 10 1/2 bit soft error rate.

Cat. C11916 \$630

Case & Power Supply to Suit

Cat. X11022 \$159

M2894

Standard size 8" drive. Double sided, double density, 96 track/inch, 9621 bit/inch, 1.6 Mbyte unformatted, 3ms track to track access, 77 track/side.

Cat. C11914 \$630

Case & Power Supply to Suit

Cat. X11011 \$89

M4854

Slimline 5 1/4" disk drive. Double sided, double density, 96 track/inch, 9621 bit/inch, 1.6 Mbyte unformatted, 3ms track to track access, 77 track/side.

Cat. 11904 \$350

Case & Power Supply to suit.

Cat. X11011 \$89

M4853

Slimline 5 1/4" disk drive, Double sided, double density, 1 Mbyte unformatted, 3ms track to track, 80 track/side, 5922 bits/inch.

Cat. C11903 \$260

M4851

Slimline 5 1/4" disk drive. Double sided, double density 500K unformatted, 40 track/side. Steel band drive system.

Cat. C11901 \$225

Case & Power Supply to suit.

Cat. X11011 \$89

M4855

Slimline 5 1/4" disk drive, double sided, double density, 96 track/inch, 2.0 Mbytes unformatted.

Cat. C11905 \$385

MF353

3 1/2" Standard size disk drive. Double sided, double density, 1 Mbyte unformatted.

Cat. C11923 \$265

MF351

3 1/2" Standard size disk drive Single sided, double density.

Cat. C11921 \$225

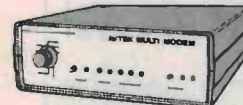

AVTEK MULTI MODEM

Features Auto Answer!
(Unlike cheaper version)

Down the street or across the world, MultiModem speaks the language.

- 300 baud full duplex, 1200 baud half duplex or 600 baud half duplex, answer or originate
- CCITT and Bell standards
- Plugs straight in (hardwired phone)
- Superior VLSI chip performance works reliably with 4dBm signal with S/N ratio of 6dB Error rate on this level is 10⁻⁵
- Telecom Approval C84/37/1135

Inc. phone, only \$399

★ ★ ★ ★ ★ ★ ★ ★ ★ ★
We stock a full range of computer connectors!
★ ★ ★ ★ ★ ★ ★ ★ ★ ★

Errors and Omissions Excepted



Rod Irving Electronics

425 HIGH STREET, NORTHCOTE VICTORIA. Ph: (03) 489 8866 489 8131 48-50 A'BECKETT STREET, MELBOURNE VICTORIA. PH: (03) 347 9251 Mail Order and Correspondence: P.O. Box 235 NORTHCOTE 3070

Call in at either 2 of our conveniently located stores: 48-50 A'Beckett St., Melbourne 425 High St., Northcote. Or take advantage of our Mail Order Department. Write to:

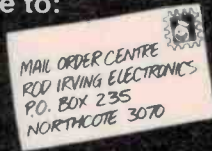

or phone ... MAIL ORDER HOT LINE



481 1436



welcome here



POSTAGE RATES
\$1-\$9.99 \$1.50
\$10-\$24.99 \$2.00
\$25-\$49.99 \$3.00
\$50-\$99.99 \$3.50
\$100-\$199 \$5.00
\$200-\$499 \$7.50
\$500 plus \$10.00

Comet road freight is extra.

PROGRAM LISTING

FLOW CHART

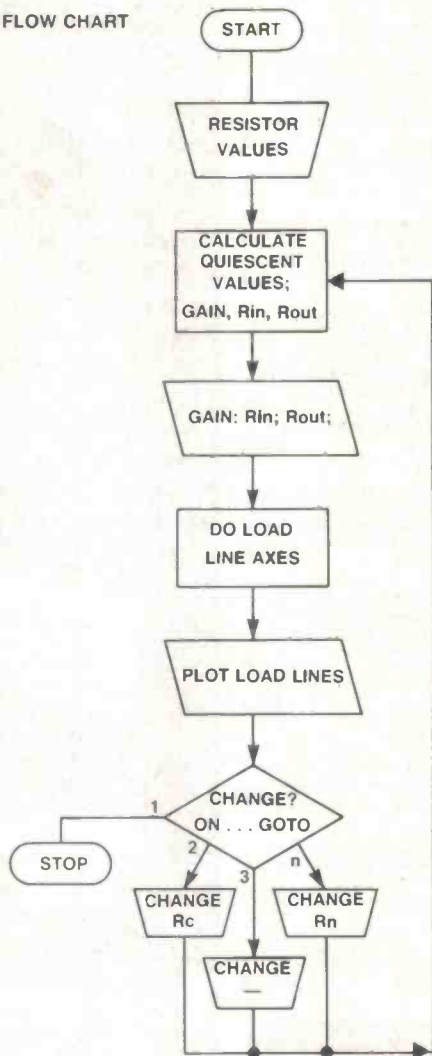

specific load. We are now in a position to ask the question about the amplifier we have designed, namely: what is the maximum output voltage I can get from this amplifier without distortion? In most applications the aim of the exercise, after all, is to magnify the input as much as possible while distorting it as little as possible.

Non-linearities

Non-linearities will occur whenever the output gets close to either end of the load line. Clipping will occur if you try to push the output past it. The idea then is to arrange your gain for a given input such that it can drive the output close to, and not right to, the end of the line. You also want to arrange things such that both positive and negative voltage excursions begin to slip at the same time. There is no point building something that will leave the positive side of the wave unclipped while distorting the negative wave badly. This state of affairs will come about when the Q point, i.e: the quiescent voltage of the transistor collector

```

10 REM*****
11 REM* THIS PROGRAM PLOTS A SET OF *
12 REM*TRANSISTOR CHARACTERISTICS WHEN*
13 REM*CERTAIN PARAMETERS ARE ENTERED.*
14 REM*THEN LOAD LINES ARE PLOTTED FOR*
15 REM*VARIOUS VALUES OF COMPONENTS. *
16 REM*****
35 PAPER 1: INK 7
38 PRINT "*****"
39 PRINT "*"
40 PRINT "* * * * * ** * * * * *"
41 PRINT "* * * * * * * * * * * *"
42 PRINT "* * * * * * * * * * * *"
43 PRINT "* * * * * * * * * * * *"
44 PRINT "* * * * * * * * * * * *"
45 PRINT "*"
46 PRINT "* LANCE WILSON, 1984 *"
47 PRINT "*"
48 PRINT "*****"
49 PAUSE 2000
50 CLS
55 REM**WRITTEN FOR THE MEMOTECH*****
56 REN** MTX500 *****
57 REM**GRAPHICS DUMP FOR CP80 PRINTER*
58 REM*****
65 REM*THESE LINES SET VIRTUAL SCREENS,
66 REM*1ST FOR TEXT, THEN GRAPHICS.
70 CRVS 2,0,3,0,36,5,40
75 VS 2: CLS : PAPER 6: INK 7
80 CSR 4,0: INPUT "COMPLEX:Y/N?";A$
81 LET PMA=200
82 LET VSF=2: LET ICMA=20
83 LET BVCEO=30: LET HFE=100
84 IF A$="N" THEN GOTO 100
85 CLS : CSR 4,0: INPUT "HFE:?" ;HFE
86 CSR 4,1: INPUT "MAX PC:?" ;PMA
88 CSR 4,2: INPUT "ICmax:?"mA";ICMA
90 CSR 4,3: INPUT "BVCEO:?" ;BVCEO
92 LET VSF=INT(ICMA/10)
100 CLS
102 CSR 4,0: INPUT " ENTER STEP";STP
104 CLS : CSR 4,0: INPUT " ENTER Vcc";VCC
105 CSR 4,0: INPUT " EMITTER&COLLECTOR R";RE,RC
106 CSR 4,3: INPUT "RB1,RB2= ?";RB1,RB2
107 LET ID=VCC/(RB1+RB2)
108 VS 4: CLS : COLOUR 2,11: COLOUR 3,4
109 COLOUR 0,1: COLOUR 1,15: COLOUR 4,6
110 REM**SETS UP AXES AND SCALES*****
111 LINE 20,12,255,12: LINE 20,12,20,190
112 CSR 5,22: PRINT "05 10 15 20 25 30 35"
113 CSR 22,21: PRINT "volts Vce"
114 FOR I=0 TO 11 STEP 1
115 CSR 0,(11-I)*2: PRINT I*VSF
117 NEXT I
118 REM**DRAWS CHAR. CURVES *****
119 LET X=20: LET Y=10
120 LET NEWX=X+STP/10: LET NEWY=Y+STP
122 LINE X,Y,NEWX,NEWY
123 LINE NEWX,NEWY,250-.8*Y,NEWY*1.11
125 CSR 30-Y/12,21-Y/7: PRINT Y+10
126 LET X=NEWX: LET Y=NEWY
127 IF Y>150 THEN GOTO 130
128 GOTO 120
129 REM*AFTER TOP CURVE, PLOT PCMA
130 FOR I=1 TO 230
135 LET YP=PMA*100/(VSF*I)
140 IF YP>175 THEN GOTO 150
142 COLOUR 3,6
145 PLOT 20+I,YP+12
150 NEXT I
151 CSR 16,10: PRINT "Pc=";PMA
153 REM*****UPPER IC & VCE LIMITS*****
154 LET ILIM=ICMA*16/VSF+12: IF ILIM>190 THEN GOTO 990
155 LINE 20,ILIM,80,ILIM
156 CSR 10,22-ILIM/9: PRINT "Imax=";ICMA
157 LET VLIM=BVCEO*6.2+20: IF VLIM>250 THEN GOTO 990
158 LINE VLIM,12,VLIM,80: CSR VLIM/9-4,18: PRINT "BVceo=";BVCEO
159 REM*****NEXT CALCS. FOR QPT. AND*****
160 REM***** DC LOAD LINE *****
161 LET ICQ=((RB2*VCC)/(RB1+RB2)-.6)/RE
  
```



```

162 LET IBQ=ICQ/HFE
163 IF IBQ*6>ID THEN GOTO 300
165 LET VCEQ=VCC-ICQ*(RC+RE)
170 LET IQX=ICQ*16/VSF+12
175 LET VQX=VCEQ*6.2+20
177 IF VQX>250 OR IQX>190 THEN GOTO 850
179 IF VCEQ<0 THEN GOTO 2000
180 CIRCLE VQX,IQX,2
185 CSR .8*VCEQ+1,22-1.65*ICQ/VSF: PRINT "0"
190 CSR 22,0: PRINT "ICQ ";INT(ICQ*10)/10
191 CSR 22,1: PRINT "VCEQ ";INT(10*VCEQ)/10
192 CSR 24,2: PRINT "RE ";RE
193 CSR 24,3: PRINT "RC ";RC
194 CSR 4,0: PRINT "RB1&2";RB1;RB2
199 GOTO 800
300 REM**
305 VS 2: CLS
308 LET S=ID/IBQ
310 CSR 6,10: PRINT "Id/Ib Ratio is "S
311 CSR 8,12: PRINT ":rather low!"
315 PAUSE 8888
320 GOTO 106
400 REM***** AC LOAD LINE *****
405 VS 2: CLS
410 INPUT "RE BYPASSED?";A$
420 INPUT "RL=? ";RL
425 LET RAC=(RC*RL)/(RC+RL)
430 LET VPK=ICQ*RAC
435 LET VPX=(VCEQ+VPK)*6.2+20
440 VS 4
443 CSR 24,4: PRINT "RL ";RL
445 LINE VPX,12,VQX,IQX
450 LET IPK=ICQ+VCEQ/VPK*ICQ
455 LET IPX=IPK*16/VSF+12
457 IF IPX>192 THEN GOTO 480
460 LINE VQX,IQX,20,IPX
470 PAUSE 7777
475 GOTO 1000
479 REM***** LIMIT CONDITIONS *****
480 LET IPX=190: LET IPK=(IPX-12)*VSF/16
482 LET VA=VCEQ-RAC*(IPK-ICQ)
483 LET VAX=VA*6.2+20
484 LINE VQX,IQX,VAX,IPX
488 PAUSE 7777
489 GOTO 1000
800 REM
810 LET IX=VCC/(RE+RC)*16/VSF+12
812 LET VX=VCC*6.2+20: REM SCALEUNITS
814 IF IX>190 THEN GOTO 900
815 LINE 20,IX,VX,12
820 PAUSE 8888
830 GOTO 400
850 REM*****GRAPHICS DUMP*****
855 CSR 15,10: PRINT "QPT OFF SCREEN"
860 GOTO 190
900 REM*TO COVER OFF-SCALE LOADLINE
905 LET IC=ICMAX
906 LET IX=IC*16/VSF+12
910 LET VX=(VCC-IC*(RC+RE))*6.2+20
916 PAUSE 9000
920 LINE VCC*6.2+20,12,VX,IX
930 GOTO 830
990 CSR 5,2: PRINT "ICMAX OFF SCREEN"
998 STOP
999 REM*****GRAPHICS DUMP*****
1000 LPRINT CHR$(27);"A";CHR$(8);
1010 FOR J=191 TO 0 STEP -8
1020 LPRINT CHR$(13);CHR$(10);
1030 LPRINT CHR$(27);"K";CHR$(254);CHR$(1);
1040 FOR I=1 TO 255
1050 LET R$=GR$(I,J,8)
1060 LPRINT R$;: LPRINT R$;
1070 NEXT I
1080 NEXT J
1099 STOP: REM*****
2000 VS 2: CLS
2001 PRINT "NEGATIVE COLLECTOR VOLTAGE"
2002 PRINT "NOT ALLOWED"
2004 PAUSE 7777
2005 GOTO 104

```

is midway between the maximum voltage excursions.

Departures

To get this far in the analysis we have made certain assumptions about the circuit which are not strictly true. Whether they are significant or not depends on the individual case. It is important to realise they are there, however, so that if you start getting results that are not as predicted you know where to look.

The first problem is that the transistor has a saturation voltage that depends primarily on the current. Saturation voltage is drawn on a load line diagram as part of the transistor collector characteristics. Usually these are drawn as a family of curves indicating the relationship between collector current and voltage for a given base current. These curves will be more or less flat in the linear operating region of the transistor, falling off on the left-hand side as the transistor goes into saturation.

In order to achieve a really accurate determination of the transistor characteristic you ideally need to make a plot for each individual transistor. Failing that, manufacturers' data is a good source for typical figures. However, for our purposes it is probably just as useful if you think of the transistor characteristic as a line passing through the origin. The slope is set by at least one typical combination of current and voltage supplied from manufacturer's data. If you don't have access to this information then a value of 0.3 V at 2 mA is typical for small signal transistors.

A second source of errors is likely to be the assumption that all the capacitors are short circuits and that stray capacitances around the circuit are negligible. As frequency goes up this will become more and more of a problem.

So far, we have thought through this problem as a simple linear process, a not very difficult programming exercise involving a few calculations and the ability to draw some lines. This doesn't really explore the potential of the computer in this regard, though. Its biggest advantage is the fact that you can very quickly see what happens to a host of different parameters of the amplifier if you change values of any of the biasing resistors, or indeed if you change resistor configurations.

We have included a flow chart that should give you some idea of how to go about writing the program. It includes a menu for making individual changes to resistors and then re-running to see the effect. We have also included a listing of a BASIC program that draws a load line diagram complete with transistor characteristics and both load lines. This is written for the Memotech computer and so will need to be rewritten by anyone using a different type of machine, but close study of how it works will be instructive.

Good luck!

WOOD FOR CHIPS ... WOOD FOR CHIPS ... WOOD FOR CHIPS ... WOOD FOR CHIPS ... WOOD FOR CHIPS ... WOOD FOR CHIPS ... WOOD FOR CHIPS ... WOOD FOR CHIPS ...

WOOD FOR CHIPS ... WOOD FOR CHIPS ... WOOD FOR CHIPS ... WOOD FOR CHIPS ... WOOD FOR CHIPS ... WOOD FOR CHIPS ... WOOD FOR CHIPS ... WOOD FOR CHIPS ...

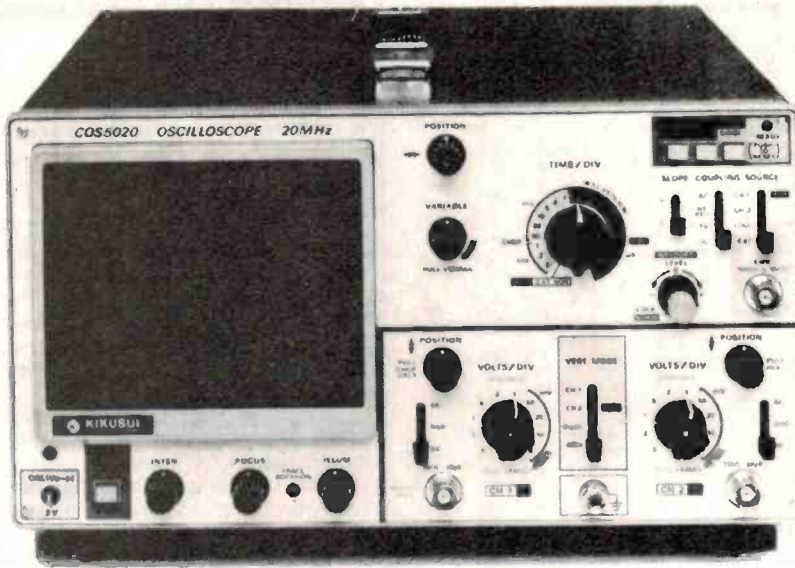

KIKUSUI 20MHz DUAL TRACE SCOPE

\$539⁰⁰ EX TAX **INC PROBES**
\$625⁰⁰ INC TAX

Compact and easy to operate for
hobbyists and professionals

- 5mV/div sensitivity
- Hold-Off function
- CH1, CH2, Dual, Add, X-Y modes
- Intensity modulation
- 5mS to 2uS sweep delay
- 0.2uS to 0.5S/div sweep range

FUJITSU PLUGS AND SOCKETS

We are now stocking an extensive range of quality Fujitsu plugs and sockets. Gold-palladium-over-nickel contacts. Double action IDC mechanism for reliable connections. PCB terminations are solder-over-nickel for easy soldering.

STRAIGHT PCB HEADERS FCN704 SERIES

- 10 pin Straight Header \$3.00
- 14 pin Straight Header \$3.20
- 16 pin Straight Header \$3.46
- 26 pin Straight Header \$4.54
- 34 pin Straight Header \$5.00
- 50 pin Straight Header \$5.95



RIGHT ANGLE PCB HEADERS FCN705 SERIES

- 10 pin Right Angle Header \$3.00
- 14 pin Right Angle Header \$3.20
- 16 pin Right Angle Header \$3.46
- 26 pin Right Angle Header \$4.54
- 34 pin Right Angle Header \$5.00
- 50 pin Right Angle Header \$5.95



SOCKET CONNECTORS FCN707B Series

- 10 way socket connector \$3.37
- 10 way socket connector \$3.37
- 14 way socket connector \$4.26
- 16 way socket connector \$4.50
- 26 way socket connector \$5.46
- 34 way socket connector \$6.13
- 50 way socket connector \$7.25



D TYPE FCN777 Series

- 25 pin female D type \$10.90
- 25 pin male D type \$8.99



IDC CONNECTORS FCN707 Series

- 34 way plug \$6.84
- 50 way plug \$7.65



NOW STOCKING A COMPLETE RANGE OF HC CMOS

MM74HC00N	1.05	MM74HC251N	1.77
MM74HC02N	1.05	MM74HC253N	1.99
MM74HC04N	1.05	MM74HC257N	1.77
MM74HC08N	1.05	MM74HC27N	1.05
MM74HC107N	1.49	MM74HC280N	8.21
MM74HC10N	1.05	MM74HC299N	10.00
MM74HC112N	1.49	MM74HC30N	1.22
MM74HC113N	1.49	MM74HC32N	1.47
MM74HC11N	1.21	MM74HC354N	9.58
MM74HC123N	4.05	MM74HC356N	9.58
MM74HC125N	3.13	MM74HC365N	4.73
MM74HC132N	2.40	MM74HC366N	4.72
MM74HC133N	1.22	MM74HC367N	4.72
MM74HC138N	2.11	MM74HC368N	4.72
MM74HC139N	1.88	MM74HC373N	4.90
MM74HC147N	2.38	MM74HC374N	4.90
MM74HC14N	1.69	MM74HC390N	2.90
MM74HC151N	1.75	MM74HC393N	2.90
MM74HC153N	1.97	MM74HC4002N	1.04
MM74HC154N	4.63	MM74HC4020N	2.71
MM74HC157N	1.47	MM74HC4040N	2.71
MM74HC158N	1.77	MM74HC4049N	1.81
MM74HC160N	2.52	MM74HC4050N	1.81
MM74HC161N	2.52	MM74HC4075N	1.04
MM74HC162N	2.52	MM74HC4078N	1.04
MM74HC163N	2.40	MM74HC423N	4.05
MM74HC164N	2.43	MM74HC42N	1.92
MM74HC174N	1.92	MM74HC4538N	4.51
MM74HC175N	1.92	MM74HC533N	4.90
MM74HC192N	2.76	MM74HC534N	4.90
MM74HC193N	2.76	MM74HC640N	4.06
MM74HC194N	2.10	MM74HC643N	4.06
MM74HC195N	2.10	MM74HC688N	6.52
MM74HC20N	1.05	MM74HC73N	1.49
MM74HC240N	4.17	MM74HC74N	1.49
MM74HC241N	4.17	MM74HC75N	1.70
MM74HC242N	3.79	MM74HC76N	1.49
MM74HC243N	3.79	MM74HC85N	3.00
MM74HC244N	4.17	MM74HC86N	1.31
MM74HC245N	4.71	MM74HCU04N	1.09

8.30 to 5 Monday to Friday. 8.30 to 12 Sat.
Mail Orders add \$3.00 to cover postal charges.
Next day delivery in Sydney add \$5.00.
All prices INCLUDE sales tax.
Tax exemption certificates accepted if line value exceeds \$10.00.



GEOFF WOOD ELECTRONICS PTY LTD

Incorporated in N.S.W.
656A Darling St, Rozelle 2039
(One door from National Street)

Tel: 810 6845



\$10.00 minimum

specialising in electronic components for the professional and hobbyist.

JED-STD/800, an Australian CMOS single board computer

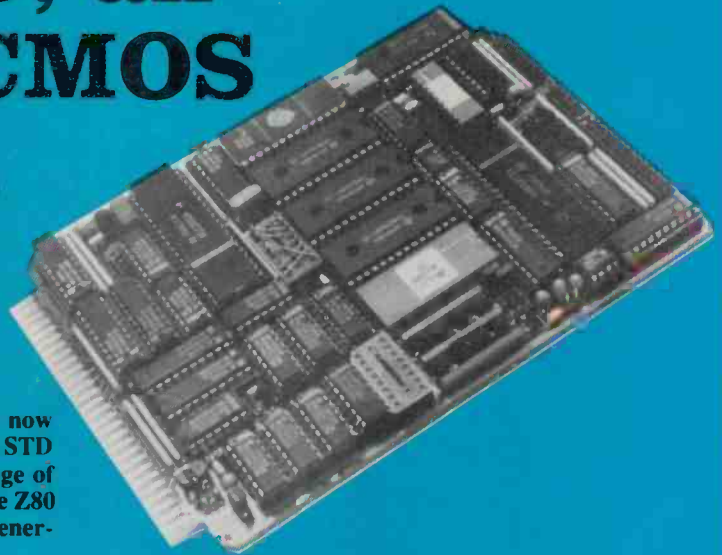

The new JED-STD/800 CMOS single board computer now in production is a completely CMOS design on the STD buss. Using the National NSC800 CPU, it takes advantage of the Z80 machine code (directly, or via any language where Z80 compilers exist), or in XT BASIC, a version of BASIC generated by JED and tailored for control applications.

According to the manufacturer the board is proving popular in applications where low power consumption and small physical size demand an unusual approach. The CMOS logic provides the low power consumption (less than 0.5 of a watt). The board is very cost competitive with other N-MOS Z80 boards because so many functions (which normally need extra boards) are packed onto one board. It can be only partly loaded, if required, for even lower cost systems (one advantage of production in this part of the world).

The JED STD/800 card puts up to 56K of memory on the STD CPU card, as well as featuring an RS232 serial I/O, 30 bits of parallel I/O, two 16-bit counter/timers, eight analogue inputs (8- or 10-bit) and a real-time clock. The possibility of using only one card in the system, thus eliminates motherboards and racks.

To make programming easy, the board comes as standard with XT BASIC, a fast BASIC interpreter with many control oriented commands and functions built in (allowing, for example, direct control of the analogue system and real-time clock from BASIC).

JMON, a powerful monitor program is also included. It pro-

vides facilities for machine code checkout (including hardware single-step of NSC800 machine instructions), and is able to exchange programs and data with CP/M systems using the serial interfaces and a 'talk-though' mode.

Source listings of JMON and the XT BASIC are automatically supplied in the manufacturer's belief that customers are much more able to understand the workings of hardware/software systems if the software sources are readily accessible.

To develop 'on-card' a BASIC control or applications program, a user simply plugs in a terminal and types in the program, using the built-in editor. The program is tested in the final hardware situation, and, when working properly, a low-cost PROM programmer (available from JED) is plugged into the parallel connector at the top of the board, and the program transferred to PROM memory. The PROMs are then plugged into the board.

There is space on-board for 32K bytes of user program. As standard, there are 8K bytes of RAM and the BASIC/Monitor PROM is in high memory.

There are links on the board and data storage locations in the built-in EEPROM which control startup and direct it to the user's program automatically. The

EEPROM also controls I/O device driver selection and baud rates. Extra space in the EEPROM is available for users.

In most applications, all the I/O needed is already on the card. The parallel I/O includes 8 or 12 power FETs as relay or opto-isolator drivers, and software to interface directly to a Centronics printer or plotter. If more is needed, it can either be added by calling on other STD buss cards on the market from JED or someone else, or it can be put onto a JED wire-wrap or point-to-point prototyping card; the only overhead with the STD buss is a handful of low-cost logic parts.

Direct serial interface is provided to both LED (or LCD) multi-digit displays and to the JED DataSafe, a portable one-inch by two-inch by four-inch diecast metal box containing up to 64K of CMOS battery backed RAM, designed for data capture in harsh environments.

The current consumption of this card is approximately 100 milliamps total, (depending on memory configuration), and it needs only a single 5 volt supply. A dc/dc converter on board generates -5 volts for RS232 output.

A plug-in card, the JED-STD/805, adds a second story to the STD/800, with two CMOS

UARTs, adding two RS232C serial channels, or a single RS232C channel and the choice of an RS422 channel or a current loop with opto-isolators, designed for use around a factory environment. The manufacturer claims it has already found many applications in Australian industry, research, and educational institutions, finding control, field data logging, and teaching uses.

JED also manufactures other STD buss cards and accessories. One of the most popular has been the low-cost battery backed RAM/PROM card. This can hold up to 56K of RAM, or any combination of RAM or PROM. It sells for about half the cost of imported cards of smaller capacity. Other items include a TTL or CMOS I/O board, the JED-STD/820 handles I/O to the OPTO-22 power I/O rack, and adds counter/timers and extra RS232C I/O to an equivalent to the Prolog 7507 or 75C07 boards; an 8-channel, 12-bit analogue output card is also in production. Low cost cabinets are also locally made.

Full data sheets, and any JED products are available from JED Microprocessors, 28 Anderson St, Boronia Vic 3155. (03)762-3588.

AR2001 WORLD'S FIRST

- CONTINUOUS COVERAGE
- THREE MODE SCANNER
- COMMUNICATIONS RECEIVER



NOW ONLY \$499
INCL. TAX

FEATURES:

- 25-550 MHz continuous
- AM — for Air band monitoring
- NBFM — for communication
- 20 CH memory
- WBFM — for BC & TV monitoring
- Priority Channel
- Clock

WRITE FOR FULL SPECIFICATIONS

NEW Personal 2-way radio here at last!

"EMTRON ACE"

A QUALITY 40-CH HIGH POWER UHF CB HAND-HELD TRANSCEIVER ● DESIGNED FOR AUSTRALIA
DOC APPROVED

FEATURES:

- 40 CHANNEL OPERATION
- HIGH (2.5W) LOW (0.5W) RF OUTPUT
- OFFSET FOR REPEATER OPERATION
- NICAD RECHARGEABLE BATTERIES
- ILLUMINATED DIAL FOR NIGHT OPERATION
- SMALL IN SIZE — BIG IN PERFORMANCE

APPLICATIONS:

- FARMING
- FISHING, BOATING, HUNTING, BUSHWALKING
- BUSH FIRE CONTROL
- AG SHOWS
- SECURITY
- CONSTRUCTION SITES
- CAR RALLIES
- CROWD CONTROL AND MANY OTHERS

DEALER INQUIRIES WELCOME



EMTRONICS

Retail Division of EMONA ELECTRONICS P/L

All Mail to: PO Box K21, Haymarket, NSW 2000
Ph: (02) 211 0531 Ph: (02) 211 0988
94 Wentworth Ave, Sydney, 2000.

MINIATURE SCALLOPED STYLE —ROCKER SWITCH—



PROMPT DELIVERY

Features Include

- SECV approved 10 amp 240 volt
- Illuminated versions
- SPST or SPDT
- Snap in panel mounting
- Panel cut-out 19.5 mm x 13 mm

Button Options



Broad Glow LED Spot Opaque



Available from:

SWANN ELECTRONICS INTERNATIONAL
PTY. LTD.

Melbourne (03) 544 3033
Sydney (02) 807 1944
N.Z. (9) 444 3620

ARE YOU ONE OF THE 138,000* WELL INFORMED BOATING ENTHUSIASTS IN AUSTRALIA?

Modern boating

AUSTRALIA'S TOP SELLING POWER AND SAIL MONTHLY MAGAZINE

*Roy Morgan Research readership survey March 1984

Laser unit offers two gigabytes of data storage

New technology from France offers a solution to the problem of accumulating libraries of data disks and tapes for Australian computer users.

Distributed in Australia by Pulsar Electronics, the new Gigadisc uses solid-state laser technology and will store 1000 megabytes (one gigabyte) of data on each single or double-sided disk cassette.

Gigadisc can be connected to almost any computer via the Small Computer System Interface (SCSI), and allows the direct accessing of any record.

The unit is attracting major interest as a low-cost storage medium for the holding of large banks of data such as continuous satellite data, says Pulsar's Managing Director, Mr Phillip Delacretaz. Other areas of high interest included TV stations storing multiple video images, CAD/CAM users, medical and scientific institutes and companies with large data bases.

"We have even had an inquiry from a large law firm seeking ways of storing large volumes of important correspondence," Mr

Delacretaz said. "The low storage maintenance costs of Gigadisc make it extremely competitive with tapes, which need to be rewound every two years."

Developed by the French company, Thomson-CSF, and distributed nationally by Pulsar, the computer peripheral can record and store data, text, digital image and speech over a period of at least 10 years.

"The viable storage life of recorded magnetic media remains limited to two to three years, even in a controlled environment," Phillip Delacretaz said.

The read/write unit of Gigadisc includes a laser and a photo/detector, and the data can be accessed by three methods, random, optimised random and sequential.

A computer interface controller can be integrated into the Gigadisc unit, which can handle up to eight Gigadisc units. Associated with this controller is an automatic error detection and correction module.

The Gigadisc is supplied in a cassette which simplifies all



handling, storage, loading and unloading operations. It also provides an additional level of environmental protection.

The disks supplied by Pulsar Electronics are preformatted into sectors and tracks and each sector is directly addressable by its logical address. Spiral organisation of the tracks allows for continuous reading and writing of streams of information.

The read-write unit is supplied either as a rack-mounted chassis or as a small stand-alone unit capable of being installed in an office environment.

With the use of the innovative laser technology, writing on the Gigadisc is achieved by the thermal alteration of a metallic film on the disc while reading is done

by a laser diffraction technique.

The inner surface of the disk is coated with a layer of polymer and a thin metallic film and while writing, the laser beam evaporates the polymer layer, causing thermal alteration ("bubbling") of the metallic film. According to Pulsar Electronics, this type of laser technology took more than seven years to develop.

Pulsar will retail the basic Gigadisc model in Australia, for approximately \$20 000. Extra two Gigabyte cassettes will be approximately \$500.

For additional information contact Mr Phillip Delacretaz, Pulsar Electronics, Catalina Drive, Tullamarine, Vic. (03)330-2555.

Low-cost line conditioning

Arlec Pty Ltd has just introduced the first of a range of line conditioners designed and manufactured in Australia for use with microcomputers and other types of voltage sensitive electronic equipment.

Rated at 250 Vac, the 80250 is designed for operation on 50 Hz only and supplies a stable 240 volt RMS sine wave output, within close voltage limits for varying mains inputs extending from 190 V to 260 V.

According to the manufacturer, input voltage fluctuations of up to 15% are regulated to within 3% at the output ensuring a constant supply with less than 5% harmonic distortion.

This performance has been achieved by means of an entirely new core structure which is the subject of a patent application. An electrostatic shield is also

incorporated for further noise reduction.

The 80250 is inherently short circuit protected and does not need any protective devices. It will operate continuously at 275 V input and take transients up to 1 kV peak without damage. In common with all Arlec products it is guaranteed for two years.

Further information is available from Arlec Pty Ltd, 30 Lexington Road, Box Hill, Vic 3128. (03)895-0222.



Stepper motors

A range of four Stepping motors, manufactured by the diversified Japanese conglomerate Toyo Corporation, has just been released. The units are designed for floppy disk drives, printers, typewriters or any other application requiring precision control.

Two of the four units utilise permanent magnet motors with four phases and offer a choice of 6 V or 12 V. Step angle in both cases is 7.5° (48 steps per revolu-

tion). Holding torque is 1100 g-cm (12 V model) or 2600 g-cm (6 V model).

The other two units utilise a hybrid type motor with 4 phases, both rated at 12 V. There is a choice of step angles: 3.75° (96 steps) or 3.6° (100 steps per revolution). Holding torque is 540 g-cm minimum.

For further information, please contact Amtex Electronics, 36 Lisbon St, Fairfield NSW 2165. (02)728-2121.

CLUB CALL

The Newcastle Microcomputer Club meets on the second and fourth Monday of each month in room G12 of the Physics Building, University of Newcastle at 7.30 pm. The club which publishes a monthly news letter is not formed around any specific brand of computer. Interested parties should contact Angus Bliss on (049)67-2433 extn 326 (office hours) or Tony Nicholson on (049)52-6017 (after hours weekdays).

Microbug Australia is the Melbourne based Microbee users group. The club meets on the second Wednesday of the month at the Victorian State College, Burwood campus, 221 Burwood Highway, Burwood, Vic, starting at 7 pm. The Vice President is A. S. Reid, phone (03)873-4455.

Tell them you read it in ETI

ELLISTRONICS

PTY.
LTD.

MELBOURNE (03) 561 5844 SYDNEY (02) 922 3220
TELEX AA37758 LSTRON

HEAD OFFICE: 797 SPRINGVALE RD. MULGRAVE, MELBOURNE, VICTORIA 3170

HYBRID REGULATORS HYBRID RE

10 AMP 5 VOLT

μ A78P05SC \$12.70

* EACH

- 10 A OUTPUT CURRENT
- INTERNAL THERMAL OVERLOAD PROTECTION
- INTERNAL SHORT CIRCUIT CURRENT LIMIT
- LOW DROPOUT VOLTAGE (TYPICALLY 2.5 V @ 10 A)
- 70 W POWER DISSIPATION
- PIN-FOR-PIN COMPATIBLE WITH THE μ A78H05, μ A78H05A AND SH323
- STEEL TO-3 PACKAGE

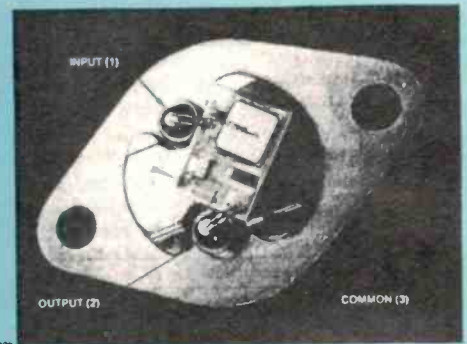
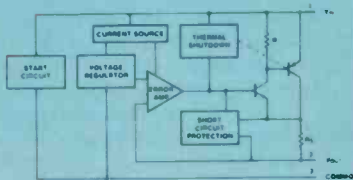

10 AMP 12 VOLT

μ A78P12 \$16.08

* EACH

- 10 A OUTPUT CURRENT
- INTERNAL THERMAL OVERLOAD PROTECTION
- INTERNAL SHORT CIRCUIT CURRENT LIMIT
- LOW DROPOUT VOLTAGE (TYPICALLY 2.5 V @ 10 A)
- 70 W POWER DISSIPATION
- PIN-FOR-PIN COMPATIBLE WITH THE μ A78H12
- STEEL TO-3 PACKAGE

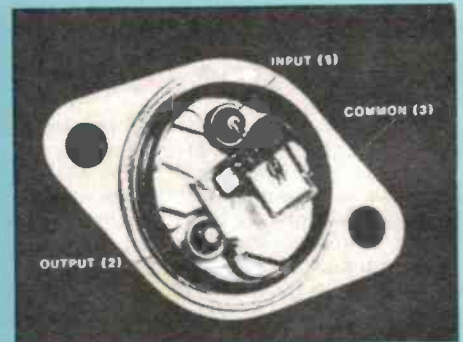
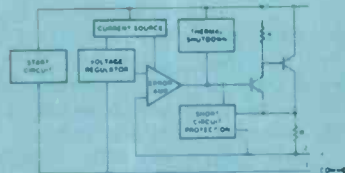

10 AMP ADJUSTABLE

μ A78PG \$16.83

* EACH

- 10 A OUTPUT CURRENT 5.0V to 24.0V OUTPUT RANGE
- INTERNAL CURRENT AND THERMAL LIMITING
- INTERNAL SHORT CIRCUIT CURRENT LIMIT
- LOW DROPOUT VOLTAGE (TYPICALLY 2.5 V @ 10 A)
- 70 W POWER DISSIPATION
- ELECTRICALLY NEUTRAL CASE
- STEEL TO-3 PACKAGE
- ALL PIN-FOR-PIN COMPATIBLE WITH μ A78HGA

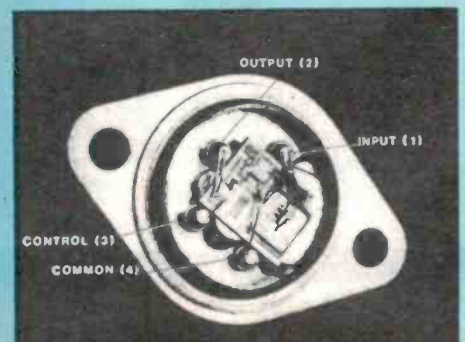
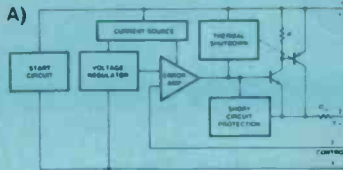

ELLISTRONICS

PTY.
LTD.

MELBOURNE (03) 561 5844 SYDNEY (02) 922 3220
TELEX AA37758 LSTRON

HEAD OFFICE: 797 SPRINGVALE RD. MULGRAVE, MELBOURNE, VICTORIA 3170

REGULATORS HYBRID REGULATORS



SH1605
(SH01605)

\$13.98

* EACH

- STEP DOWN SWITCHING REGULATOR
- OUTPUT ADJUSTABLE FROM 3.0 TO 30 V
- 5 A OUTPUT CURRENT
- HIGH EFFICIENCY
- UP TO 150 W OUTPUT POWER

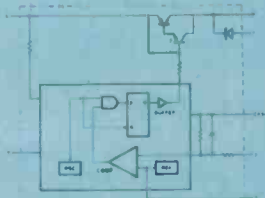

μA323SC
(UA323)

\$4.66

* EACH

- 3.0 A OUTPUT CURRENT
- INTERNAL CURRENT AND THERMAL OVERLOAD PROTECTION
- INTERNAL SHORT CIRCUIT PROTECTION
- LOW DROPOUT VOLTAGE (TYPICALLY 2.0 V @ 3.0 A)
- 30 W POWER DISSIPATION
- STEEL TO-3 PACKAGE
- ALL PIN-FOR-PIN COMPATIBLE WITH THE LM323, SG323, SH323

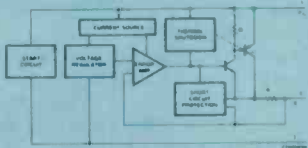

μA78H05ASC
(78H05ACC)

\$6.20

* EACH

- 5.0 A OUTPUT CURRENT
- INTERNAL CURRENT AND THERMAL OVERLOAD PROTECTION
- INTERNAL SHORT CIRCUIT PROTECTION
- LOW DROPOUT VOLTAGE (TYPICALLY 2.3 V @ 5.0 A)
- 50 W POWER DISSIPATION
- STEEL TO-3 PACKAGE
- ALL PIN-FOR-PIN COMPATIBLE WITH THE μA323

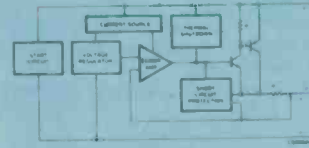

μA78H12ASC
(78H12ACC)

\$7.44

* EACH

- 5.0 A OUTPUT CURRENT
- INTERNAL CURRENT AND THERMAL LIMITING
- INTERNAL SHORT CIRCUIT CURRENT LIMIT
- LOW DROPOUT VOLTAGE (TYPICALLY 2.3 V @ 5.0 A)
- 50 W POWER DISSIPATION
- ELECTRICALLY NEUTRAL CASE
- STEEL TO-3 PACKAGE
- ALL PIN-FOR-PIN COMPATIBLE WITH μA78HG

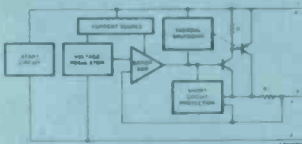

μA78HGASC
(78HGXXCB)

\$7.34

* EACH

- 5.0 A OUTPUT CURRENT
- INTERNAL CURRENT AND THERMAL OVERLOAD PROTECTION
- INTERNAL SHORT CIRCUIT PROTECTION
- LOW DROPOUT VOLTAGE (TYPICALLY 2.3 V @ 5.0 A)
- 50 W POWER DISSIPATION
- STEEL TO-3 PACKAGE

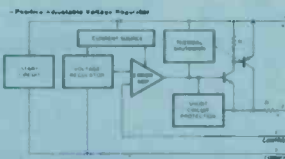

μA79HGSC
(79HGXXGC)

\$13.07

* EACH

- 5.0 A OUTPUT CURRENT
- INTERNAL CURRENT AND THERMAL OVERLOAD PROTECTION
- INTERNAL SHORT CIRCUIT CURRENT LIMIT
- LOW DROPOUT VOLTAGE (TYPICALLY 2.2 V @ 5.0 A)
- 50 W POWER DISSIPATION
- ELECTRICALLY NEUTRAL CASE
- STEEL TO-3 CASE

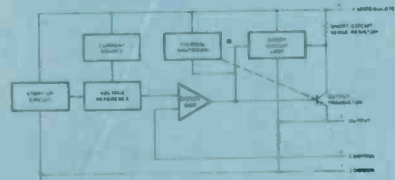

PRICES PLUS SALES TAX
IF APPLICABLE

**ELLISTRONICS
NOW IN SYDNEY.
922 3220**



LINEAR BOOK

\$16

PRODUCTS MANUFACTURED BY

FAIRCHILD

A Schlumberger Company

ONE OF THE WORLDS LEADING
SEMICONDUCTOR MANUFACTURERS

*Prices shown are for minimum quantities of 100 x each device - Larger quantities: prices on application. All prices correct at publication date.

VICDUMP

L. Murakami, West Beach SA 5024

This program may be of interest to readers who persevere with using an RS-232 printer with the VIC-20. (Real men don't use Commodore peripherals!) The purpose of the program is to enable one to dump a block of memory (in hex) to an RS-232 printer. It was developed because VIC-20 machine code monitors such as VICMON and HESMON do not support RS-232 printers.

Program structures is as follows:

- Line 40 opens the RS-232 channel at a data rate of 300 baud. The baud rate can be readily changed by changing the CHR\$ value e.g. CHR\$(165) for 150 baud and CHR\$(167) for 600 baud.
- Lines 70-160 gets from the user the desired printer column width from the options of 20, 40, or 80 columns.
- Lines 180-240 Inform the printer as to the column width. The program was developed using an Axiom EX800 series printer which uses the ASCII character codes GS, RS and US for setting the column width. Other printers may require the CHR\$ values in lines 220-240 to be changed.
- Lines 260-410 get from the user the required address range (in hex) of the memory block to be dumped.
- Lines 430-580 dump the data to the printer.
- Lines 600-610 are the program exit point whereby the RS-232 channel is closed so that other programs can be run.
- Lines 640-720 perform a hexadecimal to decimal conversion while lines 740-870 perform the opposite function.
- Lines 890-1010 get the desired character string from the keyboard.
- Lines 1030-1110 are used to instruct the user as to the format that is to be used for entering the column width and address range.

The program is suitable for any version of the VIC-20.

ERRATA

Mr C. Morris has advised that his C64 program hints (September 1984) are not as useful as he first thought. If you fit a 'momentary-on' switch between reset and ground you might damage some ICs. This circuit should perform the reset function without destroying your computer.

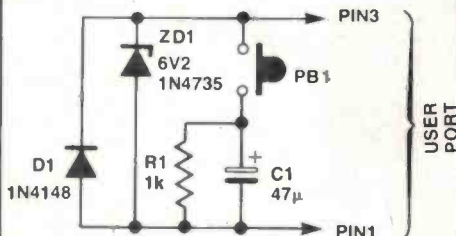

ROCKY RALLY ▽

D. Simpson, Armidale NSW 2350

This game is written for the VIC-20 in the standard 5K. The car is driven using the two cursor keys or the joystick to avoid the rocks and the barriers. There are three stages accompanied by variations in colour and sound.

```

10 REM*****
20 REM*****VICDUMP*****
30 REM**OPEN RS-232 PORT,(300BAUD)**
40 OPEN20,0,CHR$(166)
50 DIMDATA(25),CHR$(166)
60 REM**GET PRINTER COLUMN WIDTH**
70 MODE$="COLUMN WIDTH"
80 MAT$="20 *40 *80"
90 GOSUB1030
100 PRINT
110 PRINTCHR$(42);
120 LGH=2:GOSUB890
130 IFFLAG=1THEN110
140 IFFLAG=2THEN600
150 IFFLAG=3THEN190
160 FORI=1TO250:NEXTI
170 REM**GET PRINTER COLUMN WIDTH**
180 IFHEX$="20"THEN220
190 IFHEX$="40"THEN230
200 IFHEX$="80"THEN240
210 GOTO100
220 WID=5:PRINT#128,CHR$(31):GOTO260
230 WID=10:PRINT#128,CHR$(30):GOTO260
240 WID=25:PRINT#128,CHR$(29):GOTO260
250 REM**GET MEMORY BLOCK TO BE DUMP**
260 MODE$="HEXDUMP"
270 MAT$="AAAA-AAAA"
280 GOSUB1030
290 PRINT
300 PRINTCHR$(42);
310 KOUNT=0
320 LGH=4:GOSUB890
330 IFFLAG=1THEN300
340 IFFLAG=2THEN600
350 IFFLAG=3THEN190
360 LGH=4:BASE=4096:GOSUB640
370 KOUNT=KOUNT+1
380 BGN=DEC:PRINTCHR$(45):GOTO320
390 TER=DEC
400 PRINT:PRINT
410 REM**DUMP MEMORY BLOCK TO PRINTER**
420 DEC=BGN:N=1:GOSUB740
430 PRINT#128,CHR$(58);HEX$(0);
440 FORI=1TOWID
450 DAT$(I)=CHR$(32)+CHR$(63)+CHR$(63)
460 NEXTI
470 FORJ=1TOWID
480 DEC=PEEK(BGN)
490 N=3:GOSUB740
500 DAT$(J)=CHR$(32)+HEX$(0)
510 BGN=BGN+1
520 IFBGN=65536THEN550
530 NEXTJ
540 FORI=1TOWID:PRINT#128,DAT$(I);NEXTI
550 PRINT#128
560
570 IFBGN<TERORBGN=TERTHEN430
580 GOTO290
590 REM**CLOSE RS-232 PORT**
600 CLOSE20
610 END
620 REM*****
630 REM**CONVERT HEX TO DECIMAL**
640 DEC=0
650 FORI=1TOLGH:SUB=48
660 CODE=ASC(MID$(HEX$,I,1))
670 IFCODE<58THEN690
680 SUB=55
690 DEC=(CODE-SUB)*BASE+DEC
700 BASE=BASE/16
710 NEXTI
720 RETURN
730 REM**CONVERT DECIMAL TO HEX**
740 HEX$(0)=" "
750 IFN=3THENRND(2)=DEC:GOTO800
760 HEX(1)=INT(DEC/4096)
770 RND(1)=DEC-HEX(1)*4096
780 HEX(2)=INT(RND(1)/256)
790 RND(2)=RND(1)-HEX(2)*256
800 HEX(3)=INT(RND(2)/16)
810 RND(3)=RND(2)-HEX(3)*16
820 FORI=1TO4:ADD=48
830 IFHEX(I)>9THENADD=55
840 HEX$(I)=CHR$(HEX(I)+ADD)
850 HEX$(0)=HEX$(0)+HEX$(I)
860 NEXTI
870 RETURN
880 REM**GET CHARACTERS FROM KEYBOARD**
890 HEX$="":FLAG=0
900 FORI=1TOLGH
910 IFHC$=IFHC$=""THEN910
920 PRINTHC$;
930 IFHC$=CHR$(13)THENFLAG=1:RETURN
940 IFHC$=CHR$(86)THENFLAG=2:RETURN
950 TEST=ASC(HC$)
960 IFTEST<48THENFLAG=3:RETURN
970 FORI=1TO4:ADD=48
980 IFTEST>57ANDTEST<65THENFLAG=3:RETURN
990 HEX$=HEX$+HC$
1000 NEXTI
1010 RETURN
1020 REM*****INFORMATION BANNER*****
1030 PRINTCHR$(147);
1040 FORI=1TO22:PRINTCHR$(184);NEXTI
1050 PRINT"MODE":SPC(3);MODE$
1060 PRINT"FORMAT":SPC(3);MAT$
1070 PRINT"PRESS RETURN TO REDO"
1080 PRINT"PRESS X TO EXIT"
1090 FORI=1TO22:PRINTCHR$(185);NEXTI
1100 PRINT
1110 RETURN
READY.

```

```

1 GOTO13000
2 POKE 36879,95:PRINT"U":S=0:FORX=0T021:POKE38884+X,0:NEXTX:CC=2:VC=0
3 POKE650,128
4 Q=7933:GOSUB12000
5 DIMJS(2,2):POKE37139,0:DD=37154:PA=37137:PB=37152
6 FORI=0T02:FORJ=0T02:READJS(J,I):NEXTJ,I
7 FORX=0T04:POKEB164+X,8:NEXTX:FORX=0T06:POKEB164+X+15,8:NEXTX
8 K=INT(RND(1)*8):POKEK+8170,25:POKEK+38890,CC+POKEB169,
9:POKEB178,8:PRINT
11 GOSUB18:S=S+5
12 PRINT"SCORE:"S
13 IFS<250THENFORX=1T090:NEXT:POKE36874,128
14 IFS>750ANDS<2000THENPOKEINT(RND(1)*8)+1+8164+6,25:POKE36877,128:
15 POKE36879,40:CC=0
15 IFS=250THENPOKE36875,128:POKE36879,108:POKE36874,0:CC=3:VC=0
16 IFS>1700THENPOKEINT(RND(1)*8)+1+8164+6,25
17 GOTO10
18 GOSUB9000:IFS2=-1THEN27
19 IFS3=1THEN30
20 GETCC$:IFCC$=""THEN27
21 IFCC$="M"THEN30
22 IFPEEK(Q)=25ORPEEK(Q)=8THEN740
23 POKEQ-7922+38642,0
26 POKEQ-22,32:POKEQ,17:RETURN
27 POKEQ,32
28 Q=Q-1
29 GOTO20
30 POKEQ,32
31 Q=Q+1:GOTO20
740 PRINT"*****BANG!"
741 POKE36878,15:POKE36874,0:POKE36875,0:POKE36877,0:POKEQ-22,0:POKEQ
-21,60:POKEQ,61:POKEQ+1,62
742 POKE36877,220
750 FORR=1T0200:NEXTR
760 PRINT"*****GAME OVER***"
765 POKE36877,0
769 PRINT" "
770 PRINT"SCORE:"S
780 FORR=1T01500:NEXTR
790 PRINT"*****COUNTRY AGAIN?(Y/N)"
800 GETK$:IFK$=""THEN800
805 S=0:C1=0
810 IFK$="Y"THEN:CLR:GOTO2
811 IFK$="N"THEN1

```

VIC-20

```

10 PRINT"Q WORD SORT"
20 PRINT"
30 DIMW$(300):N=0
40 PRINT"ENTER WORDS TO BE SORTED OR 'Q' TO QUIT"
50 PRINT" 'B' TO GO BACK"
60 W$="":INPUTW$:IFW$="Q"THEN110
70 IFW$="B"ANDN<>0THENPRINT"BACK 1":N=N-1:GOTO60
80 IFW$=""THENPRINT"ERROR":GOTO60
90 N=N+1:W$(N)=W$
100 GOTO60
110 T=0
120 FORI=1TON-1
130 IFASC(LEFT$(W$(I),1))<ASC(LEFT$(W$(I+1),1))THEN150
140 W$=W$(I):W$(I)=W$(I+1):W$(I+1)=W$:T=1
150 NEXT
160 X=X+N:IFX>N12THEN180
170 IFT=1THEN110
180 FORI=1TON:FORL=1TON
190 IFW$(I)=W$(L)ANDI<LTHENFORJ=LTON+1:W$(J)=W$(J+1):
NEXTJ:N=N-1:W$(J+1)="
200 NEXTL:NEXTI
210 PRINT" " : INPUT"PRINTOUT(Y/N)";P$
220 IFP$="Y"THENOPEN1,4:CMD1:GOTO270
230 FORI=1TON
240 PRINTW$(I)
250 NEXT
260 END
270 FORI=1TONSTEP2
280 PRINTW$(I)CHR$(16)"40"W$(I+1)
290 NEXT
300 PRINT#1:CLOSE1
310 END

```

VIC-20

```

815 GOTO800
820 PRINT"***GAME OVER***"
830 END
9000 POKEDD,127:S3=-((PEEK(PB)AND128)=0):POKEDD,255
9010 P=PEEK(PA):S2=((PAND16)=0):RETURN
12000 POKE36879,13
12002 FORX=1TO3
12005 POKE36875,180
12006 FORR=1TO50:NEXTR
12010 POKE36875,190
12011 FORR=1TO20:NEXTR
12015 POKE36875,200
12016 FORR=1TO50:NEXTR
12021 FORR=1TO50:NEXTR
12022 NEXTX:POKE36875,0
12023 RETURN
12920 POKE36875,210
13000 CLR:POKE36879,14:POKE36869,240:PRINT" ** ROCKY RALLY ** "
13005 PRINT" BY DUDLEY SIMPSON"
13007 PRINT" TO DODGE ROCKS "
13010 PRINT" USE KEYS: "
13011 PRINT" CRSR←=LEFT CRSR←=RIGHT"
13012 PRINT" OR USE JOYSTICK "
13017 PRINT" YOU ACCELERATE AT 250 "
13018 PRINT" AVALANCHES OCCUR AFTER 750 POINTS "
13020 PRINT" GOOD LUCK!! "
13030 PRINT" HIT ANY KEY TO START "
13035 PRINT"
13040 GETB$:IFB$=""THEN13040
13045 PRINT":GOTO13102
13050 POKE36869,255:GOTO2
13102 IFPEEK(52)=28THEN13107
13103 POKE51,0:POKE52,28:POKE55,0:POKE56,28:CLR:CB=7169
13104 READA:IFA=-1THEN13107
13105 FORN=0TO7:READB:POKECB+A*8+N,B:NEXT
13106 GOTO13104
13107 GOTO13050
13140 DATA2,0,0,0,0,0,0,0
13141 DATA8,204,204,48,48,204,204,48,48
13142 DATA17,165,255,189,36,165,255,189,24
13143 DATA25,62,95,189,250,118,62,60,24,0,7,26,101,168,144,136,158,0
13144 DATA60,224,24,166,65,113,89,63,1,61,166,146,136,102,24,7,0,0
13145 DATA62,133,105,81,134,24,96,128,0,-1
13200 DATA-23,-22,-21,-1,0,1,21,22,23

```

◀ WORD SORT

A. Elphick, Frenchs Forest NSW 2086

This program will sort out a number of words or sentences into alphabetical order and delete any words or sentences that are repeated more than once.

When entering the words, 'Q' will continue with the program and 'B' will delete the last word entered.

Lines 10-100 input the words to be sorted, lines 110-170 sort the words alphabetically, lines 180-200 delete any words that are repeated more than once, and lines 210-310 print out the result. This program will work on any configuration of memory.

```

1 REM**VIDEO TITLE BOARD
2 REM BY PAUL & BARB JOHNSON
9 PRINT"
10 PRINT"1-WHITE":PRINT"2-GREEN"
11 PRINT"3-BLUE":PRINT"4-LT.BLUE"
12 PRINT"5-LT.YELLOW":
PRINT"6-BLACK"
13 PRINT"7-PICK SCREEN COLOUR"A$
14 INPUTA$
20 IFA$="1"THENGOTO30
21 IFA$="2"THENGOTO60
22 IFA$="3"THENGOTO90
23 IFA$="4"THENGOTO120
24 IFA$="5"THENGOTO150
25 IFA$="6"THENGOTO180
30 FORC=24TO31
31 POKE36879,C
32 PRINT"
50 FORT=1TO1000:NEXTT
51 NEXTC
52 GOTO30
60 FORC=88TO95
61 POKE36879,C
62 PRINT"
80 FORT=1TO1000:NEXTT
81 NEXTC
82 GOTO60
90 FORC=104TO111
91 POKE36879,C
92 PRINT"
110 FORT=1TO1000:NEXTT
111 NEXTC
112 GOTO90
120 FORC=232TO239
121 POKE36879,C
122 PRINT"
140 FORT=1TO1000:NEXTT
141 NEXTC
142 GOTO120
150 FORC=248TO255
151 POKE36879,C
152 PRINT"
170 FORT=1TO1000:NEXTT
171 NEXTC
172 GOTO150
180 FORC=8TO15
181 POKE36879,C
182 PRINT"
200 FORT=1TO1000:NEXTT
201 NEXTC
202 GOTO180
READY.

```

VIC-20

VIDEO TITLE BOARD

P & B Johnson, Leigh Creek SA 5731

This program was designed for use in conjunction with a video. We use it for titling our own home-made movies.

We have chosen these screen colours as the other colours don't combine well with writing.

To insert the title in the required colour enter the text in lines nos. 33-49, 63-79, 93-109, 123-139, 153-169 or 183-199.

```

00100 REM          PROGRAM DAY
00110 REM This program, when given any date after 1582 will
00120 REM calculate the day of the week.
00130 REM This can give Granny quite a surprize..
00140 REM Written by David S Rapson, S. Australia 5050 11/3/84
00150 CLS
00160 INPUT "Enter date: dd,mm,yyy "iD1,M1,Y1
00170 PRINT
00180 IF D1<1 OR D1>31 THEN 160
00190 IF M1<1 OR M1>12 THEN 160
00200 IF Y1<1582 THEN 160 :REM Gregorian calendar only!
00210 IF M1=1 OR M1=2 THEN LET F1=365*Y1+D1+31*(M1-1)+FLT(INT((Y1-1)/4))-FLT(INT(
0.75*FLT(INT(((Y1-1)/100)+1)))
00220 IF M1=2 THEN LET F1=365*Y1+D1+31*(M1-1)-FLT(INT(0.4*M1+2.3))+FLT(INT(Y1/4)
)-FLT(INT(0.75*FLT(INT((Y1/100)-1))))
00230 F2=-F1/7 :REM 7 days in one week!
00240 A1=F2/10 :REM cant have integer>65534, need special routine as f1 is about
720,000 depending on the date.
00250 A2=FPACT(A1)
00260 A2=FLT(INT(A2*10))
00270 F2=FLT(INT(A1))*10+A2 :REM end of integerising section!!
00280 D2=F1+(F2*7)
00290 PRINT "That's a "I
00300 IF D2=0 THEN PRINT"Saturday"
00310 IF D2=1 THEN PRINT"Sunday"
00320 IF D2=2 THEN PRINT"Monday"
00330 IF D2=3 THEN PRINT"Tuesday"
00340 IF D2=4 THEN PRINT"Wednesday"
00350 IF D2=5 THEN PRINT"Thursday"
00360 IF D2=6 THEN PRINT"Friday"
00370 PRINT: PRINT"Another date? "I
00380 Y1=KEY$
00390 IF Y1="Y" OR Y1="y" THEN 150
00400 IF Y1="N" OR Y1="n" THEN END
00410 GOTC 360

```

```

00100 REM          Program SUN
00110 REM This program will calculate the time of Sunrise and
00120 REM Sunset for any place in the world.
00130 REM The program is based on Adelaide, but given the decimal
00140 REM latitude(- for south), longitude(- for east), and the
00150 REM time difference to Greenwich, London,(- for west)
00160 REM any other place may be calculated.
00170 REM The default location can be changed at lines 200,240
00180 REM Written by David S Rapson 12/10/84
00190 CLS
00200 PRINT"Are you in Adelaide? "I
00210 Y1=KEY$
00220 IF Y1="Y" OR Y1="y" THEN 250
00230 IF Y1="N" OR Y1="n" THEN 270
00240 GOTD 210
00250 L1=-35 : L2=-135.58 : G5=+9.35 :REM lat, long, GMT difference for Adelaide

00260 PRINT : GOTD 310
00270 PRINT "No" : PRINT
00280 INPUT"What is the town's Latitude:(+ for N, - for S) "iL1
00290 INPUT"What is the town's Longitude:(+ for West, - for East) "iL2
00300 INPUT"And it's GMT difference:(+ for East of Greenwich) "iG5
00310 PRINT : PRINT
00320 INPUT"Enter date: eg. dd,mm "iD1,M1
00330 IF D1<1 OR D1>31 THEN 310
00340 IF M1<1 OR M1>12 THEN 310
00350 S1=0 :REM Correction for Daylight saving, Nov-Mar Inc.
00360 IF Y1="N" OR Y1="n" AND L10 THEN 390
00370 IF M1<2 THEN LET S1=1
00380 IF M1>10 THEN LET S1=1
00390 C1=0.01745329
00400 T1=3.9884*(D1+30.3*(M1-1))
00410 H1=23.5*(COS((T1+10)*C1))
00420 E1=0.123*(COS((T1+87)*C1))-(SIN(2*(T1+10)*C1))/6
00430 X1=SIN(H1*C1)/COS(H1*C1)*SIN(L1*C1)/COS(L1*C1)
00440 C2=(1.570796-ATAN(X1/SQR(1-X1*X1)))/C1:REM arccos(x1)/C1
00450 G1=12-E1+(L2-C2)/15
00460 G2=12-E1+(L2+C2)/15
00470 R1=G1+G5
00480 R2=G2+G5
00490 IF R2>12 THEN LET R2=R2-12 :REM keeps 12 hour time
00500 B1=(R1-FLT(INT(R1)))*60/100 :REM converts decimal to mins
00510 B2=(R2-FLT(INT(R2)))*60/100
00520 U1=FLT(INT(R1))+B1+S1
00530 U2=FLT(INT(R2))+B2+S1
00540 PRINT : PLAY 24,1
00550 PRINT"Sunrise ":(F5.2 U1):" am"
00560 PRINT"Sunset ":(F5.2 U2):" pm"
00570 PRINT: PRINT "Another date ?"I
00580 Z1=KEY$
00590 IF Z1="Y" OR Z1="y" THEN 310
00600 IF Z1="N" OR Z1="n" THEN END
00610 GOTD 580

```

DAY

David Rapson, Bellevue Heights, SA 5050

This program can be used to calculate the day of the week for any date after 1582.

SUN

David Rapson, Bellevue Heights, SA 5050

This program will calculate the time of sunrise and sunset for any place in the world. The program is based on Adelaide, but given the decimal latitude (+ for North, - for South) and longitude (- for West, + for East) any other place can be calculated.

THE CONVERTER

Jon Barnett, Northmead, NSW 2152

The Converter converts an assembly file listing into a BASIC listing. To use it, assemble and save it to tape. Load the assembly listing you wish to convert, making sure it does not clash with the conversion program. Load the Converter In and run it. It will warm-start to BASIC once the conversion process has finished. Next it must be saved to tape by typing: "OUT 2:LIST:PRINT CHR\$(26):OUT 0". Cold-boot to BASIC and reload the program by entering IN 2.

Now replace the characters which indicate tab spacing with space characters to achieve proper spacing like that of an assembly listing. Save the list-

```

00010 I *****
00020 I *****THE CONVERTER*****
00030 I *****
00040 I *****THIS PROGRAM WILL DECODE ANY ASSEMBLER *****
00050 I *****FILE AND CONVERT IT INTO A BASIC FILE. *****
00060 I *****DESIGNED BY J.L.BARNETT*****
00070 I *****DESIGNED FOR THE MICROBEE V5.1 SERIES. *****
00080 I *****WRITTEN ON THE 10TH FEBRUARY 1984. *****
00090 I *****
00100 I
00110 I
00120 I
00130 I
00140 IPROGRAM STARTS AT 7A00H
00150 ORG 7A00H
00160 DGDSPR EQU 800CH LOCATION OF BASIC PRINT ROUTINE
00170 START LD B,12
00180 CALL DGDSPR
00190 LD C,14
00200 LD HL,MESSAG
00210 CALL PRINT
00220 LD BC,(10BH)
00230 CALL ADDRESS
00240 PUSH DE SAVES THE LOCATION OF PROGRAM
00250 EX DE,HL
00260 ITHE END OF THE FILE IS SEARCHED FOR
00270 SEARCH LD B,2
00280 FINDFF LD A,(HL)
00290 INC HL
00300 CP 255
00310 JR NZ,SEARCH
00320 DJNZ FINDFF
00330 DEC HL
00340 LD A,127
00350 POP DE
00360 CP M CHECKS IF HL POINTS TO ROM AREA
00370 JR NC,CONTIN
00380 ERROR MESSAGE DISPLAYED AND DELAY GENERATED
00390 LD HL,ERRORN
00400 LD C,8
00410 LD B,12
00420 CALL DGDSPR
00430 LD B,10
00440 CALL DGDSPR
00450 CALL PRINT
00460 CALL OAAFBH DELAY ROUTINE FROM BASIC
00470 JR START
00480 CONTIN LD HL,900H
00490 ILINE NUMBER IN ASSEMBLER FORMAT IS REVERSED
00500 IAND THIS BECOMES THE CORRECT FORM FOR BASIC
00510 IHL IS THE POINTER TO SOURCE CODE AND DE IS
00520 ITHE POINTER TO THE GENERATED BASIC PROGRAM.
00530 LINEMU LD A,(DE)
00540 LD C,A
00550 INC DE
00560 LD A,(DE)
00570 LD (HL),A
00580 INC HL
00590 LD (HL),C
00600 CP 255 LOOKS FOR END OF FILE MARKERS
00610 JR NZ,NOTEND
00620 CP C
00630 JR Z,BASIC
00640 NOTEND INC HL
00650 INC DE
00660 LD A,(DE)
00670 LD B,A
00680 INC A
00690 LD (HL),A BYTE CONTAINING THE LINE LENGTH
00700 INC DE

```

BANISH THAT 'BAD LOAD' ETI, September 1984.

Max Maughan, Engineering Manager of Applied Technology, (designer and manufacturer of Microbees) has advised that the idea of the September Issue "Banish that 'Bad Load'," is good for microphone input on a standard cassette recorder, but under test by him on the Micron data cassette the signal was very weak; it would reload on the Micron cassette but not on a standard recorder.

Applied Technology is presently selling a Datatree computer cassette data unit which will not work with the circuit added and this is a reason why the output from the Microbee cannot be set to suit a microphone input only.

Also, with the Datatree the cassette load or input circuit in the Microbee is not needed. The Datatree cassette has a TTL level output and cannot be connected directly to pin 27 on the PIO. The circuit cannot be changed to suit the one application, advises Max.

ing to tape as a BASIC program using SAVE. The reason I wrote this program was that I have an assembler but no printer and my friend has a printer but no assembler. Therefore to get any listings required of me to change assembler to BASIC.

```

00710 INC HL
00720 LD (HL),32 ;INSERT A SPACE AFTER LINE NUMBER
00730 INC HL
00740 LD C,91
00750 ;THE REST OF THE LINE,CONTAINING THE ACTUAL SOURCE CODE
00760 ;IS NOW STORED.TAB CHARACTERS (9) ARE REPLACED BY ALTE-
00770 ;RNATE CHARACTERS.THE FIRST TAB IN A LINE WILL BE REPL-
00780 ;ACED BY C,THE SECOND BY V,THE THIRD BY J,THE FOURTH BY
00790 ;#CHR(94),ETC.THIS ALLOWS FORMATTING THE FILE TO NORMAL
00800 ;ASSEMBLY LISTINGS USING THE BASIC CX COMMAND.
00810 CONTEN LD A,(DE)
00820 CP 9 ;CHECKS FOR TAB CHARACTER
00830 JR NZ,NOTTAB
00840 LD A,C
00850 INC C
00860 NOTTAB LD (HL),A
00870 INC HL
00880 INC DE
00890 DJNZ CONTEN
00900 LD (HL),13 ;CARRIAGE RETURN INSERTED
00910 INC HL
00920 JR LINENR
00930 ;BASIC POINTERS ARE SET AND MACHINE CODE PROTECTED
00940 BASIC LD (225B),HL ;POINTER TO PROGRAM END
00950 LD HL,32512
00960 LD (175B),HL ;VARIABLES AREA POINTER
00970 LD HL,4900H
00980 LD (2304),HL ;FIRST LINE NUMBER
00990 LD SP,7A00H
01000 LD HL,79FFH
01010 LD (0A0H),HL ;TOP OF MEMORY POINTER
01020 CALL 8021H ;WARM START BASIC
01030 ;ROUTINE PRINTS MESSAGE:HL=START OF MESSAGE,C=LENGTH
01040 PRINT LD B,(HL)
01050 INC HL
01060 CALL DGDSPR
01070 DEC C
01080 JR NZ,PRINT
01090 RET
01100 ;GETS THE START LOCATION IN HEX AND STORES IT IN DE
01110 ADDRESS CALL #44
01120 LD D,E
01130 CALL KEY
01140 RLCA
01150 RLCA
01160 RLCA
01170 RLCA
01180 LD E,A
01190 CALL KEY
01200 OR E
01210 LD E,A
01220 RET
01230 ;KEYBOARD TRAP ROUTINE,BC HAS LOCATION ON SCREEN
01240 KEY INC BC
01250 KEY CALL 8006H
01260 LD (BC),A
01270 SUB 48
01280 JR C,KEY1
01290 CP 10
01300 RET N
01310 SUB 7
01320 CP 10
01330 JR C,KEY1
01340 CP 16
01350 JR NC,KEY1
01360 RET
01370 MESSAG DEFN 'START ADDRESS:'
01380 ERRORM DEFN 'NO FILE'
01390 DB 7
01400 END

```

GRAPHICS CREATOR

S. Robjohns, Somerton Park, SA 5044

This program is written for the Microbee Personal Computer and allows you to draw shapes on the computer screen in HIRES and LORES graphics. A cursor can be moved over the screen area and lines drawn between selected points as determined by the user. The co-ordinates of these points are retained and printed out so that they can be used in PLOT statements in later programs to recreate the shapes.

The command keys which control the cursor are: 'E' — to move cursor up, 'X' — to move cursor down, 'S' — to move cursor left, 'D' — to move cursor right, 'M' — to save cursor position, 'I' — to start another trace, 'L' — to end graphic and print coordinates.

Each graphic can comprise a maximum of 30 independent shapes each containing up to 100 lines.

These values may be changed in lines 130 and 410 to suit other memory capacities. When using HIRES graphics you are limited to 128 PCG characters. This number is continually monitored and displayed in the top left corner of the screen. Also directly below this number appears a letter which corresponds to the last command given from the keyboard. This can be useful when you are not sure whether you have entered the 'M' or 'I' commands.

In the program as presented, it is assumed a printer is connected to receive the printout of the point co-ordinates. If this is not the case then the following lines should be changed to:

```

480 SPEED 50
600 SPEED 0

```

This will allow time to use the 'CTRL S' command to halt the output if necessary.

```

00100 REM HIRES/LORES - Graphic Creator
00110 REM S.L. Robjohns
00120 CLS
00130 DIM A(101,31),B(101,31),M(31)
00140 CURS1,3:PRINT"Enter 'L' FOR LORES : 'H' FOR HIRES":CURSO
00160 K0=KEY$:IF K0="" THEN 160
00170 IF K0="H" OR K0="h" THEN HIRES:CO$="HIRES":X=256:Y=102:O=511:R=208:GOT
0 190
00180 IF K0="L" OR K0="l" THEN CLS:LORES:CO$="LORES":X=64:Y=19:O=127:R=23:GO
TO 190 ELSE 160
00190 FOR C=1 TO 64:CURS1,3:PRINT" ":NEXT C
00200 CURS5:PRINT" I ":CURS69:PRINT" I "
00210 CURS8:PRINT"Cursor Movement : E - up X - down S - left D - right"
00220 CURS72:PRINT" M - save point I - another trace L - finish graphic"
00230 SET X,Y
00240 C=0:I=0:J=0:K=1:U=0:T=0:K1$=""
00250 CURSO:PRINT USED
00260 ON ERROR GOTO 620
00270 CURS65:PRINT K1$
00280 IF X=0 THEN RESET X,Y:X=1:SET X,Y:GOTO 320
00290 IF X=0 THEN RESET X,Y:X=0-1:SET X,Y:GOTO 320
00300 IF Y=0 THEN RESET X,Y:Y=1:SET X,Y:GOTO 320
00310 IF Y=R THEN RESET X,Y:Y=R-1:SET X,Y
00320 K1$=KEY$
00330 IF K1$="E" OR K1$="e" THEN LET E=X:F=Y:Y+1:SET X,Y:RESET E,F:GOTO 370
00340 IF K1$="X" OR K1$="x" THEN LET E=X:F=Y:Y-1:SET X,Y:RESET E,F:GOTO 370
00350 IF K1$="S" OR K1$="s" THEN LET E=X:F=Y:X-1:SET X,Y:RESET E,F:GOTO 370
00360 IF K1$="D" OR K1$="d" THEN LET E=X:F=Y:X+1:SET X,Y:RESET E,F
00370 IF U=1 THEN SET U,V
00380 IF K1$="M" OR K1$="m" THEN LET M=1:U=X:V=Y:T=0:GOTO 430
00390 IF K1$="L" OR K1$="l" THEN LET I=1+1:M(1)=J:GOTO 470
00400 IF K1$="I" OR K1$="i" THEN LET I=1+1:M(1)=J:J=0:K=K+1:T=1
00410 IF I=30 OR J=101 THEN CURS16,4:PRINT"Maximum number of shapes or lines":GO
TO 650
00420 GOTO 250
00430 J=J+1:A(J,K)=X:B(J,K)=Y
00440 IF J<2 THEN 250
00450 PLOT A(J,K),B(J,K) TO A(J-1,K),B(J-1,K)
00460 GOTO 250
00470 CLS
00480 CURS16,7:INPUT"Ready printer, then press RETURN"K3$:CLS:OUT#1 ON:REM SPEE
D 50 (without printer)
00490 PRINT:PRINT CO$:PRINT
00500 IF T=1 THEN LET I=1-1
00510 FOR P=1 TO I
00520 PRINT" PLOT ("
00530 IF M(P)<0 THEN LET M(P)=1
00540 FOR G=1 TO M(P)
00550 PRINT A(G,P)";",B(G,P)
00560 IF G<M(P) THEN PRINT" ) TO ("
00570 NEXT G
00580 PRINT" )":PRINT
00590 NEXT P
00600 OUT#0:REM SPEED 0 (without printer)
00610 END
00620 IF ERROR C = 16 THEN LET C=1:GOTO 640
00630 CLS:PRINT"Error ";ERROR C1" in Line ";ERROR L:END
00640 CURSO:PRINT USED:CURS14,4:PRINT"You have used all the PCG characters"
00650 CURS12,16:PRINT"Do you wish to save these coordinates?"
00660 K2$=KEY$:IF K2$="" THEN 660
00670 IF K2$="Y" OR K2$="y" THEN LET I=1+1:M(1)=J-C:GOTO 470
00680 IF K2$="N" OR K2$="n" THEN CLEAR:GOTO 120 ELSE 660

```

IAN J. TRUSCOTTS

Electronic World Kits, tools, components books etc.

Products from
Dick Smith
&
Altronics

Everything for the
electronic hobbyist

Now open till 9pm
Friday evenings.

Electronic World
Cnr. Lacey St. and
Windsor Rd.
Croydon, 3136, Vic.
Phone: (03) 723 3094

SHOP AROUND

The information in this section is to assist readers in the continual search for components, kits, printed circuit boards and other parts for ETI projects and circuits.

ETI-342 Pulse-shaped CDI

Most of the components for this project should be readily available from the majority of electronics suppliers. You may have to shop around for the potcore for L1 and toroid for L2, however; we'd suggest you try places like *Geoff Wood Electronics* or *Radio Despatch Service* in Sydney, or *All Electronic Components* in Melbourne. The same places should be able to help with the more esoteric capacitors: C1, C2 and C6, and with the less common semiconductors D1, D10, Q4 and IC1. If you're after a complete kit, try *Altronics* in Perth, *Jaycar* in Sydney and *Rod Irving* in Melbourne. *Dick Smith Electronics* has advised that it may also be producing a kit.

ETI-170 CRO calibrator

The only parts in this project that are likely to cause any availability problems are the rotary switches, SW2 and SW3. These aren't as readily available nowadays as they were, although most suppliers should be able to get them for you even if they don't normally carry stocks. If you have trouble, suitable switches from the 'Lorlin' range (type RA for SW2, type CK for SW3) are available from *C & K Electronics Pty Ltd*, at

PO Box 229, Parramatta, NSW 2150 or 15 Cowper Street, Harris Park. Phone (02)635-0799. For complete kits, try *Altronics*, *Jaycar* or *All Electronic Components*.

ETI-742 Speech-tailored speaker

The 6-inch speaker used in our prototype was from *Jaycar* in Sydney, type H16CP60-02C. Low in cost, it's ideal for the job; in fact the design is based on this speaker, so it would be unwise to make any substitutions. Everything else should be readily available.

ETI-666 Printer switch

The only parts in this project that may involve a little shopping around are the insulation-displacement connectors. You should be able to get these from *Geoff Wood Electronics*, *Radio Despatch Service*, or *Sheridan Electronics* in Sydney and from *All Electronic Components* or *Rod Irving Electronics* in Melbourne. *Jaycar* and *Altronics* would also be worth trying. If all else fails, or if you want to save money, solder-type Centronics plugs and sockets will be available from an even wider range of suppliers.

Artwork

Here are prices for this month's projects:

ETI-342: pcb — \$3.30

ETI-170: pcb — \$3.60; panel — \$5.10

ETI-666: pcb — \$2.15; panel — \$1.60



Beginners Computing!

Just starting? Choose one of these titles. They make computing seem like child's play!



PROGRAMMING FOR REAL BEGINNERS: BOOK 1

H0344A \$7.95

Written for complete beginners, this book assumes no previous knowledge of computing at all, and guides you gently through the initial stages of building up simple programs. The text is written to be non-machine-specific, and so can be used with any micro that is programmable in BASIC.

COBOL FOR BEGINNERS

H0140P \$33.95

It is a solid text for introductory programming courses in Cobol, using a format that is easy to understand, yet comprehensive enough to make supplementary readings unnecessary.

PROGRAMMING FOR REAL BEGINNERS:

BOOK 2

H0387A \$11.50

This book introduces you to the stages involved in planning a program, including the use of flowcharts, and explores the wider range of facilities the computer has to offer. You'll also learn how to plan your screen displays attractively to make your programs really user friendly.

DON'T (OR, HOW TO CARE FOR YOUR COMPUTER)

H0153A \$19.95

A guide to computer and peripheral preservation. Specific advice for the computer, floppy disks, hard disks, the CRT terminal, the printer, tape units, the computer room, software and documentation.

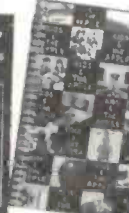

YOUR FIRST COMPUTER

H0271A

\$15.25

An easy-to-understand beginner's book to small computers. Understanding them, buying them and using them for personal and business applications.

KIDS AND THE APPLE

H0300P

\$25.75

How to write programs for the Apple computer, including action games, board games and word games.

SEND YOUR ORDER TODAY!

FEDERAL MARKETING BOOK SALES

Simply fill out the reply-paid card insert

140 JOYNTON AVENUE, WATERLOO, NSW 2017

Mark Lingane

COMMODORE PLUS/4



Commodore goes for the low-end business market! This powerful little package comes with built in business software designed to be really user friendly as well as 'user useful'. It's packed with features not offered elsewhere, so Commodore might be onto a winner.

THE NEW Commodore Plus/4 is the next generation 64. In brief, it can be described as having everything the model 64 should have had, but didn't.

The Plus/4 is something of a 'different' beast for Commodore. It is so-named because of the four applications programs included in read-only memory in the machine. Quite a departure for many computer companies, Commodore not excepted. The four programs are the sort of thing a small business person or freelancer could usefully use in day-to-day business: word processing, file management, spreadsheets and graphics. The four programs can share and exchange information and the Plus/4 has a 'split screen' or 'windowing' facility which allows viewing of the operating parts of two of the packages simultaneously.

For the record, the hardware has 64K of RAM (60K available to the user), a 'help' key (which all newcomers will make much use of) and an advanced version of BASIC for those who want to get into programming. It will work in conjunction with many of the VIC-20 and Commodore 64 peripherals. It costs only around \$599 and, while aimed initially at the smaller business market, the Plus/4 is expected to appeal to home computer buffs, too.

Commodore Australia is no 'johnny-come-lately' on the computer scene. They've been operating here for four years and have sold over 200 000 computers, they claim, during that time. They have an Australia-wide network of outlets and a corporate structure to support increasing sales here, having undergone a bit of a re-

arrangement a few months back.

First impressions

The first thing you notice about the Plus/4 is its bold new look. It is charcoal black with white keys which gives a 'space' look to the whole machine. However, the keyboard has a 'clackety' feel about it which gives the impression of a cheap set of keys. All the graphics characters, and colour functions etc are printed on the keys giving the keyboard a cluttered look. The keys are easy to read though.

At last Commodore has included all the colour functions on the keys; something that was missed on the 64. Instead of remembering that to get the colour orange you need to press the Commodore key and the 2, now you just look at the key and it has the letters 'ORG' on it, indicating the colour orange.

New features

A new feature includes a flashing characters feature. Press the 'Flash' key and whatever you type will flash on and off. Ideal for warnings.

One of the most important new features is that of window capability. Not quite the same as Apple's Macintosh but still, it's a start. On the 40 characters by 25 lines you can define your own screen, for example, a 20 character by 10 line screen in the middle of the screen or a 40-by-5 at the bottom of the screen as a control window. Possibilities are limited only by your ingenuity.

The cursor keys are now arranged in a cross. That is, there are now four cursor

keys, each one pointing in the appropriate direction. A great idea which should have been incorporated in the Commodore machines much earlier.

Another new feature included (as against omitted on the 64) is the Disk Operating System. Useful commands such as DIRECTORY, DLOAD, DSAVE, SCRATCH (deletes files), RENAME, BACKUP and many others are available. This feature is about the best one that could have been included on the Plus/4. The time that it will save and the ease of use is immeasurable, I think.

BASIC etc

Commodore has also included a decent BASIC this time round. It features a massive 75-word command/function vocabulary, including DRAW, SOUND, COLOR and many others. Commands are included for graphics, sound, editing and debugging. The Plus/4 is a real breeze to program without delving into the murky depths of machine code.

Speaking of machine code, the Plus/4, like the Commodore 16, has a built-in machine language monitor. This includes 12 powerful commands such as Assemble, Disassemble, Transfer and others which will make Commodore 64 owners sick with envy. What will make the 64 owners even more jealous is the fact that when they bought their 64 it boasted 64K of RAM with only 39K available, whereas on the Plus/4 the power-up message states that there is over 60K free for BASIC programming! I can see the previous 64 owners ▶

COMPUTER REVIEW

reaching for the bank book now. But *still* the Plus/4 has more features.

Plusses for the Plus

The function keys are predefined. This means that when you press them something happens; not like the 64 where they must be programmed. The keys can be changed by simply typing the word 'KEY' and all the functions that the keys are doing are displayed and can be altered.

The function keys and the powerful BASIC included means that you don't need to be a programming genius to use the machine to its full potential. Quite a different machine to the 64 in that way. This change may be caused by the fact that the Plus/4 is aimed at the business market and not the home user or computer boffin, and the business people who cannot always afford the time to learn how to program the machine to make it do simple tasks.

For example, to clear the high resolution screen on the 64 in BASIC took about two minutes and a lot of number remembering. On the Plus/4 one statement is required, SCNCLR, and is instantaneous. Which would you prefer?

Another business plus is that the Plus/4 fits into a brief-case very easily as it is about three quarters the size of the Commodore 64. The keyboard is the right height to mini-

mise wrist fatigue, unlike the 64 which was too high off the table surface to facilitate hours of constant typing.

Graphics

The graphics have been improved greatly. Impossible, I hear you say! No so. Now, instead of having 16 colours to choose from you have 128. That is, 16 colours with eight shades each (though I cannot see how you can have eight shades of black).

The graphics can almost equal the supreme graphics of the Atari home computers. The high resolution screen has not changed much from the 64. It is still 320 by 200 pixels or 160 by 200 in multicolour mode (more than one colour on the screen at a time).

With the command GRAPHIC you can jump into high resolution mode. Following the command with the number two gives you four lines of text at the bottom of the screen, a feature which is fairly common to most forty character screens.

Sound

With the sound it looks as though Commodore has taken a backward step as they have dropped the powerful programmable SID chip and replaced it with a more common tone generator. This step was most probably done with business use in mind. Sound

enveloping and programming ADSR might seem a bit excessive if you only want to produce simple monotonic sounds.

On-board software

The real strength behind the Plus/4 is what comes on board and how its name is derived. On board there are four business packages; word processing, spreadsheet, database and a graphics package. This makes the Plus/4 a sort of 'Super-Adam' (Colecovision's home/business computer system).

Each of these programmes can be accessed by pressing just one key. The ultimate for business? — a complete office at the touch of a button! But if Commodore wishes to pursue the lower end business market they definitely need an 80 column alternative. This I think is the only weak point of the Plus/4.

Summary

The Plus 4 has many plusses and very few minusses. I am almost tempted to say that it has everything that a computer user might want. But that would mean that the Commodore Plus/4 is the perfect machine. I don't think we are at that stage of the ultimate computer, but the Plus/4 takes us that one step closer. ●

MINI MART

COMMUNICATIONS

WANTED: FOR COLLINS R390A — modules, particularly if strip and serial C/O. Also Collins handbook, purchase or loan. D. Bruce (03)587-1593.

COMPUTERS

FOR SALE: ZX-SPECTRUM 48K as new with ±250 programs \$450 ono. Will separate. Write to J. Crest, 175 Trafalgar St, Stanmore 2048.

MICROBEE unwanted original software. Ztrek, Chess, Robotman, Pilot, Escape from Colditz — \$6 each. Chopper, Kilopepe, Sydney Approach \$8 each. J. Arnold (02)625-8950.

FOR SALE: SUPER 80 Disassembler, cassette \$9; teleprinter \$40; vintage valves, new from \$1, include 6L6-G, 809, CV4060. Send SSAE for the price list. R. Vowels, 93 Park Dve, Parkville 3052.

DISK DRIVES, Siemens FDD 100-8, 8", single sided, double density, IBM 3740 format compat, all power connectors, manual, Shugart 801R compatible, brand new, \$325 each. (02)929-6497 (ah).

VZ200 SOFTWARE, cash book ledger, assembler, utilities, hardware tips etc. Send SAE to Mr J. C. E. D'Alton, 39 Agnes St, Toowong, Qld 4066.

FOR SALE: COMPUTERS — Arcade game board "Warlords" includes: 6502 CPU, 16K EPROM (8 x 2716) wiring diagram, harness, artwork, fully working. Can be used in Arcade or experimented on. \$100. (09)447-8819.

FOR SALE: SINCLAIR ZX81 — 16K RAM, full size keyboard, green phosphor monitor, cassette recorder, plenty software, mags. Package \$400. Will sell individually. (03)49-5587.

FOR SALE: MICROBEE 32K+ with Wordbee, Edasm, green screen monitor, DataTree tape recorder, joystick and over \$200 software. The lot for \$600. (02)869-1113.

FOR SALE: Computer Blorhythm Printout for nine months plus notes \$4 posted. Send date of birth with name to Comprint 'Bellambee', Cassilis Road, Mudgee 2850.

FOR SALE: \$100 boards DGZ80 CPU, DG640 VDU, ETI-681 PCG, 2 x 16K RAM, and mother board, all working order. Any offers? C. Cogzell, 28 Stuart St, Toowoomba 4350. (07)32-1832 ah.

FOR SALE: \$100 ENTHUSIASTS — 4 boards DGZ80, ETI-640 VDU, 16K RAM, I/O port board as new. Plus 10 slot mother board, power supply. Manuals Incl. Only \$500 ono. G. Knott, Newcastle (049)57-5421.

FOR SALE: SYSTEM 80/TRS 80 programs. For information contact Raymond Schatz, 53 Yass St, NSW 2594.

FOR SALE: ACT VIC-20 bimonthly magazine. Many interesting articles and programs. December issue \$2. Bimonthly \$12 per year. Write to Chris Groenhout, 25 Kerferd St, Watson 2602.

FOR SALE: BATTLESHIP: TRS80, 1, 2, 4. Requires 2 computers or modem. Send SASE for info to C. Cranstone, 17 Helen St, Christie Downs 5184.

AUDIO

FOR SALE: REALISTIC ST/500, SA/500, SCT/500 tuner, amplifier, deck, cost \$879, sell for \$479; plus Bearcat 150 FB scanner, cost \$285, sell \$199; plus an ac intercom, cost \$119, sell \$75 or \$575 the lot. Nino Paradiso, 12/12 De Munska St, Windsor 3181.

MISCELLANEOUS

FOR REPAIRS, modifications or building of ETI, EA projects, even custom designs. Contact Andrew Newcombe, 66 Gellibrand St, Campbell ACT. (062)47-7601.



AVTEK MULTI MODEM

Features Auto Answer!
(Unlike cheaper version)

- ★ 300 baud full duplex, 1200 baud half duplex or 600 baud full duplex, answer or originate
- ★ CCITT and Bell standards
- ★ Plugs straight in (hardwired phone)
- ★ Superior VLSI chip performance works reliably with 4dBm signal with S/N ratio of 6dB Error rate on this level is 10⁻⁵
- ★ Telecom Approval C84/37/1135

Inc. phone, only **\$399**



MINI MODEM

- ★ 300 baud full duplex
- ★ Answer originate
- ★ Plugs straight in (hardwired phone)
- ★ Superior VLSI chip performance (identical to Multi Modem)
- ★ Telecom Approval (C84/37/1173.)

Incl. phone only **\$199**

PRINTERS GALORE

★ NEW ★ NEW



MB100S

The next generation of "80" type printers. 100 CPS, internal buffer expandable to 4K, Greek as well as italics. The print quality is the same as its forerunner. Square pins and film ribbon make it unbeatable.

1-4 **\$325** 5+ **\$299**

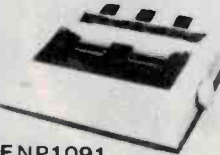

ENP1091

The latest addition to our range. Has a near letter quality mode. 120 CPS. Down loadable character set. Graphics, Italics, emphasized etc.

Was **\$500** Now **\$420**



Juki printer

Professional daisy wheel printer 18 CPS full incremental mode Diablo 630 emulation. Large range of daisy wheels. 8K internal buffer available.

Was **\$950** Now **\$790**



Star Gemini 10

120 CPS logic seeking Italics, graphics and down-loadable characters sets Friction and tractor 9 x 9 matrix. Hi res. graphics Low cost typewriter ribbon

Was **\$430** Now **\$360**



Star Gemini 15

120 CPS logic seeking Italics, graphics and down-loadable characters sets Friction and tractor 9 x 9 matrix. Hi res graphics Low cost typewriter ribbon.

Was **\$899** Now **\$729**



Star Radix 15

Excellent fast printer 200 CPS eats up the pages With an amazing 16K internal buffer you won't waste any time. Has near letter quality mode. graphics, and font variation.

\$1,395

MONITOR MADNESS

COLOUR IS HERE IN A BIG WAY!!



PHOENIX V

Available late November. Order now for Xmas!

- Pal. Suits Apple, Commodore even your V.C.R!
- ★ Pal and R.G.B
- ★ Normal Res.
- ★ 13" CRT Dot Pitch 0.65mm
- ★ Horiz. Resol. 320 TV Lines
- ★ Vert. Resol. 560 TV Lines
- ★ Display Characters 1000 Ch. (40 x 25)
- ★ 16 Colours (Pal)
- ★ Green Text Display

Cat. X14522 **\$449**

PHOENIX IV

Suits 'IBM' R.G.B. Input

Cat. X14520 **\$690**

RITRON 1



Our most popular model in a steel cabinet to minimise R.F.I. Interference. Prices include tax. Make sure you get in early.

1-4 **\$139** 5-9 **\$135** 10+ **\$129**

Cat. X14500 (Green) **\$139** Cat. X14500 (Amber) **\$135** **\$129**

RITRON II



Swivel base monitor in stylish case.

1-9 **\$169** 10+ **\$159**

Cat. X14506 Green **\$169** Cat. X14508 Amber **\$159**



"IBM TYPE"

COMPUTER CASING

Give you kit computer a totally professional appearance with one of these 'IBM type' casings Includes room for 2 5 1/4 inch disk drives and connection ports. Dimensions: 49x39x15cm

Cat. X11090 **\$89.00**



SWIVEL BASE

Makes life easier, normally **\$29.50**

Cat. D11100 **\$22.50**



DISK STORAGE BOXES

25's or 50's

Efficient and practical! Protects your disks from being damaged or lost. Solves all those hassles of finding "that" disk.

Cat. C16025 25 Disk Box **\$29.50**
Cat. C16050 50 Disk Box **\$49.50**



INCREASE YOUR MEMORY

	1-9	10+
4116	1.80	1.70
4164	4.95	4.50
2716	6.25	5.95
2732	6.25	5.95
2764	8.25	7.95
27128	27.00	25.00
6116	6.95	6.75



MITSUBISHI DISK DRIVES

M2896-63

Slimline 8" Disk Drive Double sided Density No AC Power required. 3ms track to track 1.6 Mbytes unformatted, 77 track side 10^{1/2} bit soft error rate.

Cat. C11916 **\$630**
Case & Power Supply to Suit **\$159**

M2894

Standard size 8" drive. Double Cat. C11914 **\$630**
Case & Power Supply to Suit **\$89**

M4854

Slimline 5 1/4" disk drive. Double sided, double density, 96 track/inch, 9621 bit/inch, 1.6 Mbyte unformatted, 3ms track to track access, 77 track/side.

Cat. 11904 **\$350**
Case & Power Supply to suit. **\$89**

M4853

Slimline 5 1/4" disk drive, Double sided, double density, 1 Mbyte unformatted, 3ms track to track, 80 track/side, 5922 bits/inch. Cat. C11903 **\$260**

M4851

Slimline 5 1/4" disk drive. Double sided, double density 500K unformatted, 40 track/side. Steel band drive system.

Cat. C11901 **\$225**
Case & Power Supply to suit. **\$89**

M4855

Slimline 5 1/4" disk drive, double sided, double density, 96 track/inch. 2.0 Mbytes unformatted. Cat. C11905 **\$385**

MF353

3 1/2" Standard size disk drive. Double sided, double density, 1 Mbyte unformatted.

Cat. C11923 **\$265**

MF351

3 1/2" Standard size disk drive Single sided, double density, Cat. C11921 **\$225**



Rod Irving Electronics

425 HIGH STREET, NORTHCOTE VICTORIA. PH:(03)489 8866 489 8131 48-50 A'BECKETT STREET, MELBOURNE VICTORIA. PH:(03)347 9251
Mail Order and correspondence: P.O. Box 235 NORTHCOTE 3070

MAIL ORDER HOT LINE



(03) 481 1436



POSTAGE RATES

\$1-\$9.99	\$1.50
\$10-\$24.99	\$2.00
\$25-\$49.99	\$3.00
\$50-\$99.99	\$3.50
\$100-\$199	\$5.00
\$200-\$499	\$7.50
\$500 plus	\$10.00

Comet road freight is extra.



KEYBOARD AND CASE

Cat. X11080 **\$249**

REPLACEMENT KEYBOARDS

★ NEW ★

- For Apple
- 42 single key BASIC command
- One chip custom design encoder
- Made by ALPS, life time - 10 million operations
- Dimension: L340xW110xH42mm

Cat. KC2001 **\$79.50**

- For Apple
- 45 built in function keys, BASIC and CP/M command.
- 45 user defined keys
- Built-in shift lock
- Made by ALPS, life time - 10 million operations
- Dimension: L340xW130xH42mm

Cat. KC2002 **\$99.00**

ADD ON DISK DRIVES FOR 6502 SYSTEM



1-9 **\$195** 10+ **\$189**

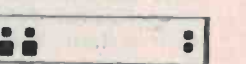

LINE CONDITIONER

Dispose of those clicks and voltage spikes forever 2 stage output, 2 outlets per stage, rated 1000 W 4A 250V 50Hz If you want a real computer system, this is for you **\$249.00**

Errors and Omissions Excepted

VERBATIM DISKS

"Lowest" price possible for "Highest" quality.

	1-9	10+	100+
MD525-01	3.95	2.75	2.50
MD550-01	4.50	3.95	3.75

VALUE LIFE box of 10 **\$22.95**

IBM COMPATIBLE COMPUTER \$2,150

Including tax!

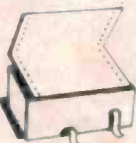

COMPUTER PAPER

Top quality at a very affordable price. Blank 11x9 1/2", 2,000 sheet, quality 60gsm bond paper

Cat. C21001 **\$29.50**



RITRON (ZETA) DATASETTE

For data loading and saving, this Micron Datasette suits most home computers and features tape counter, monitor function for audio verification and slide volume control for output level

Cat. C14900 **\$29.95**

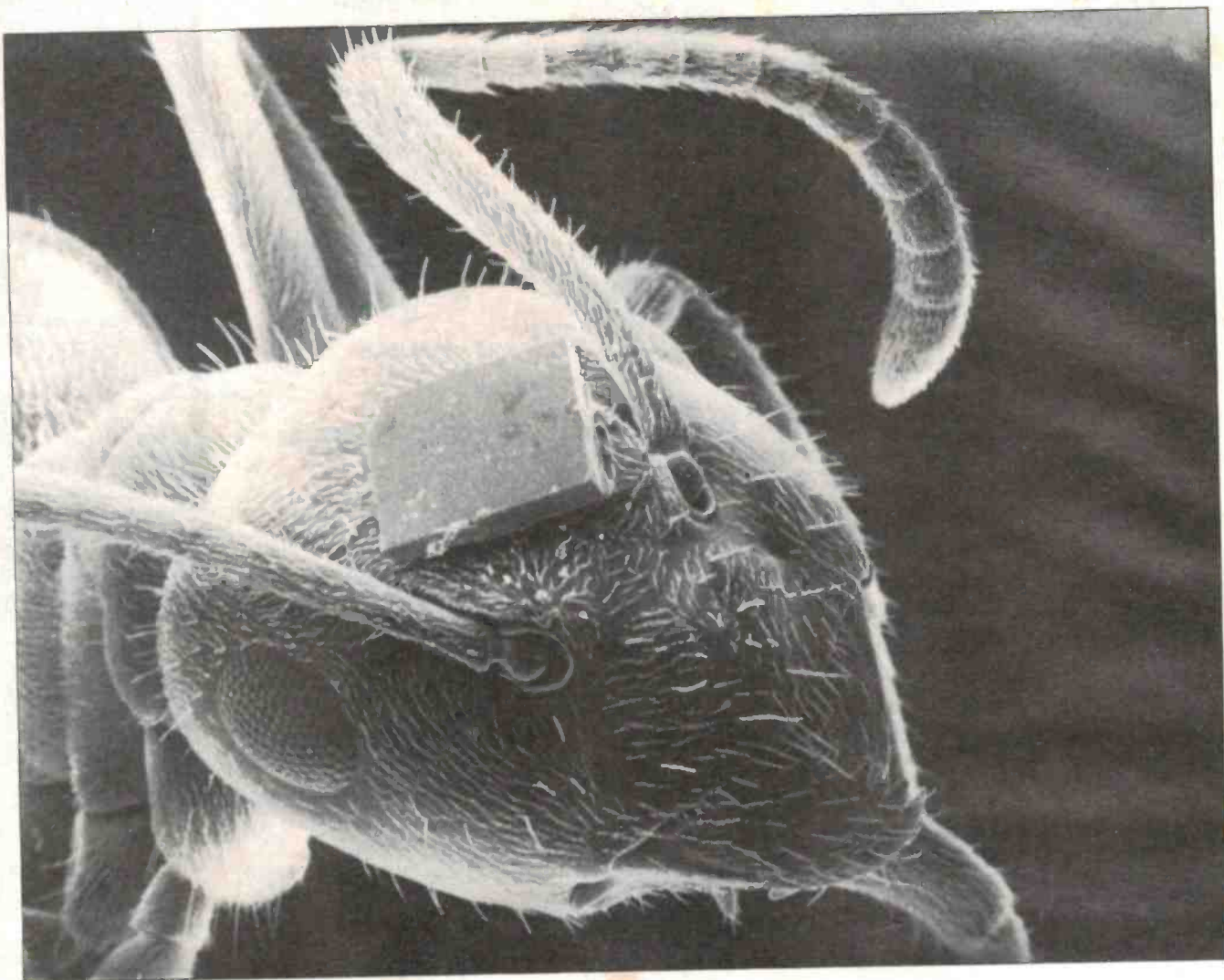

Ants

We received the picture above from an outfit calling itself British Telecom. I take it this is the pommy version of our own dear phone company. Anyway, this go ahead organisation has designed a chip configured as a laser to project pulses of light through hair thin optical fibre.

The electron microscope pic shows just how small the chip is — that's an ant's head it's sitting on.

Questions arise. Why is it so small? What is it doing on an ant's head? Is it really a chip at all?

At a recent lunchtime brain storming session, held at an establishment not terribly far from our office, ETI staffers tried to solve this and other mysteries of the universe. Numbers between 41 and 43 were not well received. Neither were references to flea brains.

One thought held that this was the British answer to threats to the empire. The idea being that the chip is actually an extremely clever mind control device embedded in the

ant's brain. By judicious selection of ant types it should be possible to find animals that will eat just about anything. So it becomes possible to direct legion after legion of ants to attack the enemy telecommunications and energy supplies, eat his bridges and buildings, destroy tapes and magnetic recording media. In short, to really screw things up.

The idea is not new. For a while the CIA (why does every Australian wind up talking about the CIA sooner or later?) was training dolphins to carry explosives to enemy shipping. They gave up on the idea when someone pointed out that the dolphins might get such a kick out of blowing up enemy ships they might start blowing up friendly ones as well. (Of course, the mathematics of this situation start to look very different if you come from a country without much of a navy . . .).

Other thought provoking military applications were suggested. For instance, the ants could be liberated in enemy territory, each with this little laser cap on its head.

When approached by the enemy the laser can be used to zap them. It's a sort of cheap star wars scenario. (And hopefully about as practical.)

Non military uses? Well, what about a radio transmitter so that entomologists can keep track of bugs and other small animals. What about medical uses? As long as doctors like sticking things into, up, down and through our collective bodies, there should be a place for a device like this. In fact, if you think about it, it really gives new meaning to the phrase: "ants in your pants".

Going . . . going . . .

Several pubs in the Waterloo, Zetland area of Sydney have reported a significant downturn in profitability since the demise of a large bearded person with a raucous laugh from this area. He was last seen staggering from the Doncaster Hotel in the direction of greener pastures. It is not known whether the pubs will survive this trauma.

The range of Hi-Fi equipment you thought was beyond your means is now within your grasp.

RECEIVERS

SEPARATE AMPS

CASSETTE DECKS

INTEGRATED AMPS
TUNERS
CASSETTE DECKS
TURNTABLES
RECEIVERS
SEPARATE AMPS
SPEAKERS
CARTRIDGES
HEADPHONES
SYSTEM COMPONENTS

A Hundred Years of Musical Experience

YAMAHA
HI-FI



Please send me the latest Yamaha Hi-Fi catalogue.

Name _____

Address _____

Postcode _____



Yamaha Hi-Fi Division, Rose Music Pty. Ltd.,
17-33 Market St., South Melbourne. Victoria. 3205.

MCR/AM 3861 E/R

FOR QUALITY, PERFORMANCE & VALUE, AARON MUST BE YOUR FIRST 'SCOPE CHOICE

(and for after sales service too!)

AARON

The most popular low cost scope



STOP PRESS
SPECIAL BULK PURCHASE
Check our new low prices.

1 BS601 - 20MHz/5mV with Built-in Component Tester

\$465 ex tax \$538 tax paid

- Check components on screen
- 19 range timebase • Triggers to over 30MHz • 17nS risetime

2 BS810 - 100MHz/1mV with 4 Channels and 8 Traces

\$2295 ex tax \$2708.10 tax paid

- 2nS/div max sweep time
- Alternate time base with B ends A mode • Variable trigger hold-off
- Independent position controls
- Signal delay

3 BS625 - 45MHz/1mV with Signal and Timebase Delay

\$998 ex tax \$1155 tax paid

- Single sweep • Trigger delay
- 7.7nS risetime • X, Y, Dual, Chop, Add, Subtract etc

4 BS310S - 15MHz/2mV Battery Portable

\$625 ex tax \$724 tax paid

- Ideal for field service use
- 2 hour operation from built-in NiCads • Automatic re-charging
- Auto trigger free run • TV sync

5 BS320 - 15MHz/2mV with Digital Storage and DMM

\$2295 ex tax \$2708.10 tax paid

- Built-in 3½ digit multimeter
- Digital storage mode • Trigger delay • X-Y mode component tester • 3 channel operation for 3-phase measurements

6 BS635 - 35MHz/1mV with Alternate and Delayed Timebase

\$675 ex tax \$781 tax paid

- 21 range timebase • 100mS-1uS trigger delay • Front panel trace rotate • Multi-mode display

Optional carrying cases available for all 'scopes.

Coline Probes

A comprehensive range of probes and accessories is available. Modular types have pencil slim heads and detachable earth leads. They offer excellent pulse responses and very wide bandwidths. A comprehensive catalogue is available on request.

SP100 - 100MHz Probe

\$25 ex tax \$29.00 tax paid

With x1, ref, x10 positions. 1.5m lead, BNC connector and selection of tips in heavy duty pouch.

All prices are plus sales tax if applicable and subject to change without notice.

SOLD & SERVICED IN AUSTRALIA BY

ELMEASCO

Instruments Pty. Ltd.

NEW SOUTH WALES

15 Macdonald Street,
MORTLAKE
P.O. Box 30, CDNCORD
NSW 2137
Tel: (02) 736 2888
Telex: AA25887

VICTORIA

12 Maroondah Highway,
RINGWOOD
P.O. Box 623, RINGWOOD
VIC 3134
Tel: (03) 879 2322
Telex: AA36206 ELMVIC

QUEENSLAND

243 Milton Road,
MILTON
P.O. Box 2360, BRISBANE
QLD 4001
Tel: (07) 369 8688
Telex: AA44062

SOUTH AUSTRALIA

99 King William Street,
UNILEY
P.O. Box 1240, ADELAIDE
SA 5001
Tel: (08) 271 1839
Telex: AA88160

WESTERN AUSTRALIA

P.O. Box 95, GOSNELLS
WA 6110
Tel: (09) 398 3362

N.S.W. Ames Agency 699 4524 • George Brown 519 5855, (049) 69 6399 • Davred 267 1385 • DGE Systems (049) 69 1625 • Macelec (042) 29 1455 • Radio Despatch 211 0191 • Sheridan Electronics 699 6912 N.T. Thew & McCann (089) 84 4999 A.C.T. George Brown (062) 80 4355 VIC. Browntronic 419 3986 • G.B. Telespares 328 4301 QLD. Colourview Wholesale 275 3188 • SL Lucia Electronics 52 7466 • Electronic Shop (075) 32 3632 • W.G. Watson (079) 27 1099 • Nortek (077) 79 8600 • ECO Electronics 376 5677 • Northern Circuits (070) 51 9063 • Fred Hoe & Sons 277 4311 S.A. Redarc Electronics 278 7488 • Trio Electrix 51 8718 • Protronics 212 3111 W.A. Atkins Carlyle 321 0101 TAS. GHE Electronics (002) 34 2233 & (003) 31 6533.

