

STILL ONLY \$2.60! NZ \$3.50  
JANUARY 1986

"Super Offer  
on 1987"

# The AUSTRALIAN ELECTRONICS

Monthly  
excitement electronics



UHF CB beam to build

Build David Tilbrook's

## 3-WAY BASS REFLEX LOUDSPEAKERS

Inside 8mm Video

## Listening Post Apple II software

- Troubleshooting car electrics with your multimeter
- Turn your Microbee into a 'Port-A-Bee'
- Australian-built speakers reviewed
- Radio Communicators Guide — variations of the ionosphere



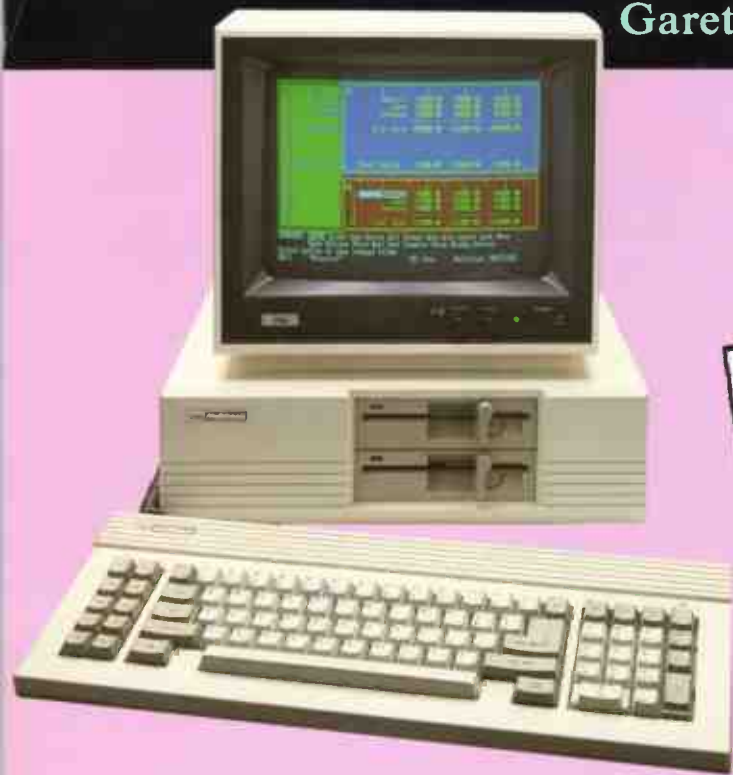
World Radio History

25  
20  
15  
10  
5  
0  
-5  
-10  
-15  
-20  
-25

20 50 100

“ . . . full-scale computing power is now well within the reach of the smallest business”:

Gareth Powell, Computer Editor, Sydney Morning Herald



**NEW!**  
**DSE Multitech**

**1/2 PRICE  
IBM  
COMPATIBILITY!** \*

This is not a toy — but a reliable computer, priced for business and home users alike. Powerful enough to handle any office task or programming demands. A versatile system that easily expands making it a computer for the future.

**Professional features . . . .**

Even the most discriminating user will appreciate the Multitech's professional characteristics. Spectacular high resolution graphics, 16 colour mode text. An industry standard, ergonomically designed keyboard boasts 84 keys, including 10 user programmable function keys and a numeric keypad. The RS-232C serial port allows computer-to-computer communication. Plus there is a host of other impressive features:

- \* **RAM:** available from 128K to 512K
- \* **ROM:** 8K for Bios and diagnostics. Socket for optional 32K (27256) user expandable.
- \* **CHARACTER SET:** 256 expandable ASCII
- \* **VIDEO:** IBM compatible colour graphics interface with 640 x 200, 320 x 200 graphics resolutions and 16 colour text mode. Video interface includes special "flicker-free" circuitry for reduced eye-strain.
- \* **CLOCK:** fully integrated crystal locked real time clock with battery back-up.
- \* **INPUT/OUTPUT:** RGB and composite video monitor outputs. Joystick/Games adaptor port. Parallel printer port, RS-232C serial communications port, and in-built speaker.
- \* **DISK DRIVES:** One slimline 360K disk drive — System One. Two slimline 360K disk drives — System Two. One slimline 360K disk drive with a 10MB hard disk — System Three.
- \* **EXPANSION:** One IBM expansion slot (for Systems One and Two)

**Unlimited software . . . .**

Unlike many other computers, the Multitech accepts an extensive range of ready-to-run software. It's compatible with the MS-DOS operating system, and runs most IBM programs straight from the box. So you can select the best programs available for any task: word processing, analysis, stock control and more. . . even games programs!

**Commercial leasing available through AGC**

\*At time of printing

**Three versions . . . .**

Best of all, the Multitech is available in three pre-configured versions —there's one to suit your budget.

**System One . . . .**

is the affordable start to powerful computing with 360K floppy disk drive, 128K RAM and MS-DOS version 2.11. Cat X-8000

**\$1395**

**System Two . . . .**

really gets down to business. Two 360K floppy disk drives, 256K RAM, MS-DOS 2.11 and the 'EASY' word processing package from MicroPro — with spelling check and six months on-site service. Cat X-8002 (In all capitals except Darwin, plus Newcastle)

**\$1995**

**System Three . . . .**

the powerful work-horse with 512K RAM, one 360K floppy disk and one 10 Megabyte hard disk drive. Includes AURA — the fully integrated business program which performs word processing, spreadsheet, database and information management. With six month on-site service agreement. For your convenience, DSE will install the Multitech System Three, free of charge. Cat X-8003 (In all capitals except Darwin, plus Newcastle)

**\$3995**

**Don't delay . . .**

visit your nearest DSE Computerstop today for a demonstration. Like Gareth Powell, we think you'll be impressed with the Multitech . . . the powerful alternative at an attractive price.

Monitor shown not included in price



Want to know more? Send for your FREE information pack. It's obligation free:

Name: .....

Address: .....

Postcode ..... Phone .....

Drop into any Dick Smith Electronics store or send to DSXpress (PO Box 321, North Ryde NSW 2113)

Dick Smith Electronics Pty Ltd

**COMPUTERSTOP** World Radio History

# The AUSTRALIAN ELECTRONICS Monthly

1985 WAS CERTAINLY AN EVENTFUL YEAR! and I'm not referring just to the launch of Australian Electronics Monthly — a significant event in itself. Some far-reaching changes in both the direction and organisation of the CSIRO last year should reflect favourably within the Australian electronics industry.

The establishment of CSIRO's Office of Space Science and Applications (COSSA) promises to do much towards thrusting our industry forward in the global space industry. A shift in the CSIRO's research priorities also promises a much-needed 'shot in the arm' for the local electronics industry. If not the 'prime mover', the CSIRO should act at least as a catalyst with a concentration on selected microelectronic devices and communication technologies, plus the application of computer technologies and microelectronics to industrial processes.

The launch of two of the three AUSSAT series of communications satellites was undoubtedly a major event with far-reaching consequences, socially and technologically. Arthur C. Clarke's prophetic proposal forty years ago has certainly proved the kernel from which a mighty crop grew!

The entrepreneurial efforts of both small and large local electronics companies last year have made some impact on the world outside our shores, and it's good to see firms like Netmap (ex-RanData), Summit communications, Statronics and our old friend, AWA, numbered among them.

And what of ourselves? Well, we certainly seemed to have stirred things up! For us, personally, it's been a highly eventful and rewarding year (though, perhaps, a little exhausting) and we look forward to 1986 with keen interest and anticipation.

To all our readers, advertisers and adversaries, we wish you all the best for 1986.



Roger Harrison  
Editor

**COPYRIGHT:** The contents of The Australian Electronics Monthly is fully protected by the Commonwealth Copyright Act (1968). Copyright extends to all written material, drawings, circuit diagrams, printed circuit boards, computer software and photographs. Although any form of reproduction is a breach of copyright, and we especially point out this extends to the construction of projects produced by our laboratory or our associates, we are not concerned about individuals constructing projects for their own private use, nor by bands for example, constructing one or more units for use in performances. Commercial organisations should note that no project or part project, including printed circuit boards produced by our laboratory or our associates and described in this magazine may be offered for sale, or sold, in fully or substantially assembled form, unless a licence has been specifically obtained to do so from the publishers, Kedhorn Holdings Pty Ltd, or from the copyright holders. We will take strenuous legal action against any person or firm found infringing our copyright as aforesaid.

**LIABILITY:** Whilst all efforts have been made to ensure that all constructional projects and circuits referred to in this issue will operate as indicated efficiently and correctly and that all necessary components to assemble the same will be available, no responsibility whatsoever is accepted in respect of the failure for any reason at all of the project or circuit to operate effectively or at all whether due to any fault in design or otherwise and no responsibility is accepted for the failure to obtain any components in respect of such project or circuit. In addition, no responsibility is accepted in respect of any injury or damage caused by any fault in the design of any such project or circuit aforesaid. The publisher accepts no responsibility for unsolicited manuscripts, illustrations, computer software or photographic material although all care will be exercised. Comments and test results on equipment reviewed refer to the particular item submitted for review and may not necessarily pertain to other units of the same make or model number.



Roger Harrison VK2ZTB  
EDITOR



David Tilbrook B.Sc.  
**PROJECT ENGINEER**  
**ADVERTISING/MARKETING**  
John Whalen

**PUBLISHER**  
Adrian Farrow  
**DRAUGHTING**  
David Currie  
**PRODUCTION**  
Marni Raprager  
Lisa Rathgen  
Angela Wilcox

**ACOUSTICAL CONSULTANTS**  
Robert Fizzell Acoustics Pty Ltd, AAC

**EDITORIAL ASSOCIATES**  
Neil Duncan VK3AVK  
B. App. Sci., Dip. Ed., M. Ed. Studs  
Alan Ford FIAADP MBIM VK2DRR/G3UIV  
Tom Moffat VK7TM  
Jonathan Scott VK2YBN  
B. Sc./B. E. (Hons)  
Bill Thomas B.A.  
Kerry Upjohn M.A.

**TYPESETTING**  
Authotype Photosetters Pty Ltd  
397 Riley St. Surry Hills 211 5076  
Published by: Kedhorn Holdings Pty Ltd, an associated company of Westwick-Farrow Pty Ltd, W.B. Building, Cnr Fox Valley Rd & Kiggle St. (PO Box 289) Wahroonga 2076 NSW  
Ph: (02) 487 2700. Tlx: AA71460 Sydney Whats New; International AA10101 Whats New.

Subscriptions: S31 20 Australia, NZ\$45 New Zealand, overseas rates on application.

Australian Electronics Monthly is printed in 1985 by Offset Alpine, Cnr Wetherill & Derby Sts, Silverwater, NSW, and distributed by Network Distributing Co. Cover price \$2.60 (maximum and recommended Australian retail price only; recommended New Zealand retail price, \$3.50) Registered by Australia Post, Publication No. NBP 7435 ISSN No 0815-5046

**ENQUIRIES**  
Advertising: John Whalen (02) 487 2700.  
Editorial: Roger Harrison (02) 487 2700.  
Technical: David Tilbrook (02) 487 1483 only after 4 30 pm EAST

Vic. Ad. Sales: Saddleton Cox & Assocs.  
13 Stewart St. Mount Waverley 3150.  
(03) 233 7933  
Pam Stewart or Leon Trimmings  
Melb Correspondent: Ian Boehm c/- Saddleton Cox. (03) 233 7933  
Qld Ad. Sales  
PO Box 247, Kenmore Qld 4069; (07) 202 6813  
Sue Horne or Rosemary Lerqessner  
W.A. Ad. Sales: Hugh Scott 122 Aberdeen St. Northbridge WA 6000. (09) 328 9177  
COPYRIGHT 1985, KEDHORN HOLDINGS P/L

# CONTENTS →

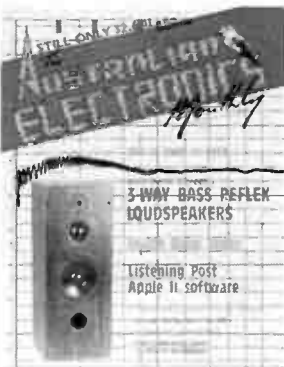
## ADVERTISERS INDEX

### COVERS

Dick Smith Electronics . . . . . IFC  
Parameters . . . . . IBC  
Convoy . . . . . OBC

### INSIDE

AEM PC boards . . . . . 99  
All Electronic  
Components . . . . . 27, 78-79  
Benelec . . . . . 84  
Daneva . . . . . 26  
Dick Smith Electronics . 6, 82-83  
108  
Electronic Facilities . 71, 102-103  
Elmeasco . . . . . 9, 107  
Emtronics . . . . . 94  
Energy Control . . . . . 75  
Electronics World . . . . . 107  
GFS Electronics . . . . . 75  
Hypac . . . . . 75  
Jaycar . . . . . 72-73, 96-97  
Jemal . . . . . 27  
Microbee Systems . . . . . 18-19  
Microtrix . . . . . 54  
Philips Elcoma . . . . . 11  
Philips I & E, T & M . . . . . 13  
Promark . . . . . 75  
Scan Audio . . . . . 16  
Siemens . . . . . 48  
Vanfi . . . . . 25  
Wireless Institute  
of Australia . . . . . 75



### COVER

The superlative bass end performance of David Tilbrook's new three-way loudspeakers is shown by the graph, taken from measurements made on the prototype. (The squiggles are simply the chart recorder's pen responding to the low frequencies.) Speaker photo by Mark Rowland, design by Marni Rapraquer.

## PROJECTS TO BUILD

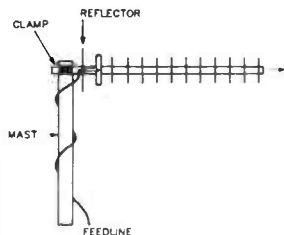


### AEM6103 Three-way Loudspeakers

..... 50  
*This month's feature project is David Tilbrook's long-awaited three-way speakers featuring Vifa drivers.*

### AEM4503 Turn your Microbee into a 'Port-A-Bee'

..... 61  
*Here's how to add a two-line by 40 column liquid crystal display to your Microbee for fully portable, mains-independent applications.*



### STAR PROJECT UHF CB Beam to Build

..... 65  
*Give your signal a real boost with this simple to build and install beam antenna from Dick Smith Electronics.*

## CIRCUITS & TECHNICAL

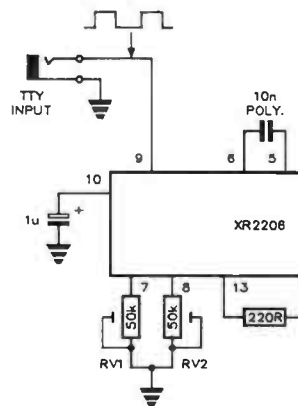


### Troubleshooting Vehicle Electrics with Your Multimeter

..... 8  
*A practical guide to using a modern multimeter in fault-finding and servicing vehicles.*

### AEM Data Sheets

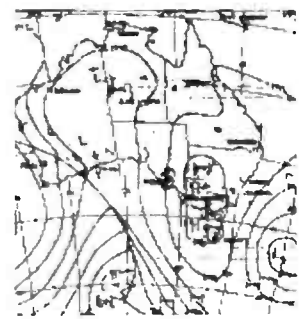
..... 104  
*Full data on the Vifa bass, mid-range and tweeter drive units employed in our feature project this month.*



### Benchbook

..... 109  
*Looking for a simple RTTY modulator as a companion to our popular Listening Post project?*

## PRACTICAL COMPUTING



### Using the AEM3500 Listening Post with the Apple II

..... 56  
*Now we do it for Apple owners! Use our project and your Apple to receive and decode radio facsimile pictures (FAX), radioteletype (RTTY) and Morse code.*

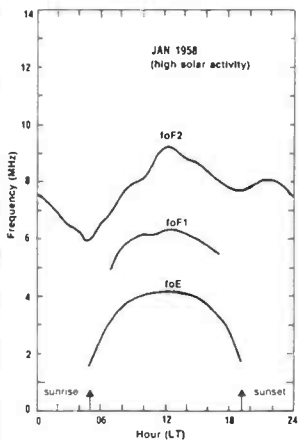
### Listening Post Software

..... 60  
*Disk or tape software for the Apple II, Commodore 64 and Microbee.*

### BeeBuzz

..... 68  
*Tom Moffat indulges in a little New-Year speculation.*

## COMMUNICATIONS SCENE



### Radio Communicators Guide to the Ionosphere, Part 4.

Variations of the ionosphere, explained in detail and with copious illustrations.



### CONTEST Win a Yaesu Scanner from Dick Smith!

Last chance to get a top-line Yaesu scanner courtesy of Dick Smith Electronics.

## CONSUMER ELECTRONICS



### Audiosound Laboratories' Motet 8011A Loudspeakers Reviewed

Bob Fitzell looks at a pair of locally-made, low-cost two-way speakers.

### V8 — the New 8 mm Video Tape Technology, Part 2

Malcolm Goldfinch concludes his rundown on the 'insides' of the new revolution in video.

## NEWS & GENERAL

News Review ..... 7  
*Picture 'phones next!*

Consumer Electronics ..... 17  
*New gear from NAD*

Retail Roundup ..... 32  
*Attention all modem constructors!*

Project Buyers Guide ..... 32  
*Where to get kits, boards and components for this month's projects.*

Byte-wide ..... 55  
*Commodore to finally release the Amiga.*

Spectrum ..... 74  
*AWA moves to 'local' production.*

New Product News ..... 95  
*BWD's Powerscope II*

Notes & Errata ..... 98

Admarket ..... 107  
*Readers' free adverts*

Subscriptions ..... 49

Printed Circuit Boards

Weller Crossword ..... 98

Last Month's Crossword Answers ..... 70

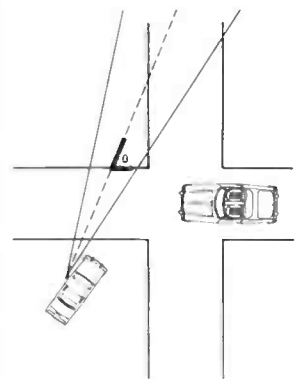
Letters ..... 112

The Last Laugh ..... 114

OFFERS  
6-Pen, A3 Plotter ..... 67

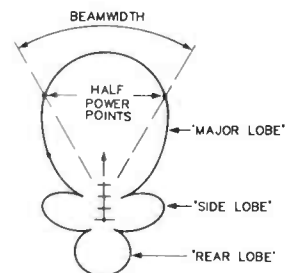
Pocket DMMs for \$49.50 ..... 27

## NEXT MONTH!



### HONESTY, FALLIBILITY AND POLICE RADAR

A technical hitch held up production of this feature, but now it's all systems go. We examine how police radars work, and what they can and can't tell in any given situation. In plain terms we describe how police radars are used and what can go wrong. In addition, we explain what to do if you feel you've been unfairly caught.



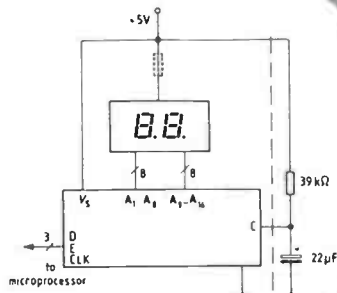
### SIMPLE TO BUILD YAGI FOR THE AMATEUR 70 CM BAND

Modern design and analysis techniques have yielded many different approaches to Yagi beam design allowing much simplified mechanical design whilst retaining good RF performance. Here's a good example. This 13 element Yagi yields around 12.5 dB gain, matches 50 ohm cable and requires no tune-up. Cheap, too!

## FEATURE

### APPLICATIONS COOKBOOK Specialised ICs

A 16-page special feature on applications of special-purpose Siemens ICs, with data, full circuits and where to get the devices.



# LITTLE DICK'S SUMMER SIZZLERS



## WIRELESS BURGLAR ALARM

Crime is on the increase! Your home, unit or office needs 'effective' security. And with DSE's Wireless Alarm System, you'll have total protection and enjoy peace of mind. This is a complete package. Included with the sophisticated Central Processor are a **passive infrared sensor** for whole room monitoring, **remote reed switch** for guarding entry/exit points and **personal remote control**. You can even extend the system by adding on more of these affordable peripherals shown below. And because it's wireless there are no expensive installation costs. Just plug the Central Processor into the power point, connect the peripherals and set the alarm. As simple as that! It's like having a personal security guard — but without the cost. Cat L-5120

Extend your system by adding 'more' of these. . .

### PERSONAL REMOTE CONTROL

Use to remotely turn the alarm on and off. Convenient! Cat L-5124

**\$39<sup>95</sup>**

### PASSIVE INFRARED SENSOR

Monitors whole rooms (covers 64sq.m.). Any movement is instantly transmitted to the CPU. Cat L-5122

**\$419**

### REMOTE REED SWITCH

Guards entry/exits. Any intrusion and the alarm sounds. Cat L-5126

**\$39<sup>95</sup>**



ALL THIS FOR ONLY **\$349**

## LOCAL AUDIO ALARMS

### LARGE PIEZO ELECTRONIC

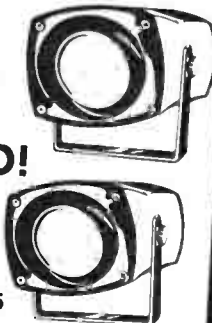
Compact but it delivers an earsplitting sound! Ideal for car, home or van alarms. Operates from 12V DC at 500mA; 110dB output at 1m. Cat L-7030

**REDUCED!**

### PIEZO ELECTRONIC ALARM

What a bargain! Amazing output for such a tiny unit! Suits most systems. Working voltage: 7.5-15 (200mA at 12V). Sound output: 110dB at 1 m. Frequency: 2800Hz. Cat L-7025

**NOW \$9<sup>95</sup>**

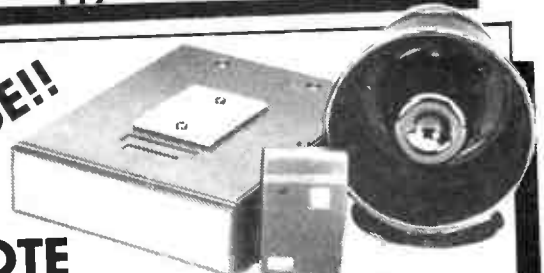


**VALUE!!**

## REMOTE SWITCHED CAR ALARM

Stops thieves 'stealing off' with your valuable car! Hard to imagine that real protection could be so affordable — but DSE covers all the angles. Features boot and bonnet trigger, ignition cut-out, battery backup capability and more. Loud 110dB siren should scare off thieves instantly. Cat L-5096

**\$159**



## CAR COMMANDER

Tells you what's happening under the bonnet!

Incredible! Every family car can have the monitoring facilities of a Formula One racer with this inexpensive unit. An LCD displays the status of vital functions: oil pressure, RPM, voltage and water temp. Programmable RPM and water temp. alarm warns of impending problems. Built-in stopwatch too! Cat Y-3011

**\$84<sup>95</sup>**



**BARGAIN!**

B.093/MM

# DICK SMITH ELECTRONICS

PTY LTD

NOW AVAILABLE AT ALL 52 DSE STORES THROUGHOUT AUSTRALIA & PARTICIPATING RESELLERS.

# "Picture phones next," says Arthur C. Clarke

A telephone call via satellite from London to a ship in the South China Sea on 21 October, marked the 40th anniversary of the mooring of communications via space.

It was UK author, scientist and futurist, Arthur C. Clarke, who first explored the possibility of using satellites stationed over certain parts of the earth to provide a new means of worldwide communications. He did so in an article that was published in a magazine then named *Wireless World* in October 1945.

Today, the magazine is known as *Electronics and Wireless World* and its Editor, Philip Darrington, paid tribute to Mr Clarke's farsightedness by using the very system he advocated to talk to him direct from London to his ship while it was en route from Hong Kong to Colombo.

The call was made from the London headquarters of the International Maritime Organisation (IMO) to the coast Earth station at EIK in Norway from where it was beamed via an Intelsat satellite, stationed above the Indian Ocean, to the SS *Universe*. The ship received the call on a dish aerial about one metre in diameter. This tiny antenna is specially stabilised so that it is always pointing at the satellite regardless of the ship's course or movement.

Clarke says he has been surprised at the speed of satellite communication developments. When he first put forward the idea he thought it would materialise nearer the end of this century.

But in the short period since the mid-1960s, hundred of satellites have been launched into the "Clarke" orbit — that is, a geosynchronous orbit where the satellite revolves with the earth to stay at the same place above one of the three major oceans so as to form a chain capable of relaying telephone calls or TV pictures to any part of the world.

Geosynchronous satellites have now become the world's dominant medium for long-distance communications. About two-thirds of the world's overseas communications are carried via satellite and almost 4000 ships, oil rigs and other

vessels are now on call to their bases from anywhere in the world via a satellite network operated by the London-based International Maritime Satellite Organisation known as INMARSAT.

Clarke believes there are immense possibilities in space still to be explored. One of the next developments could enable people to see one another when they speak to each other via space, he predicts.

John F. Webb

## Get onto Viatel and "reap the benefit"

We hear from Dick Smith Electronics of their new decoder suitable for connection to Telecom Australia's Viatel videotex service.

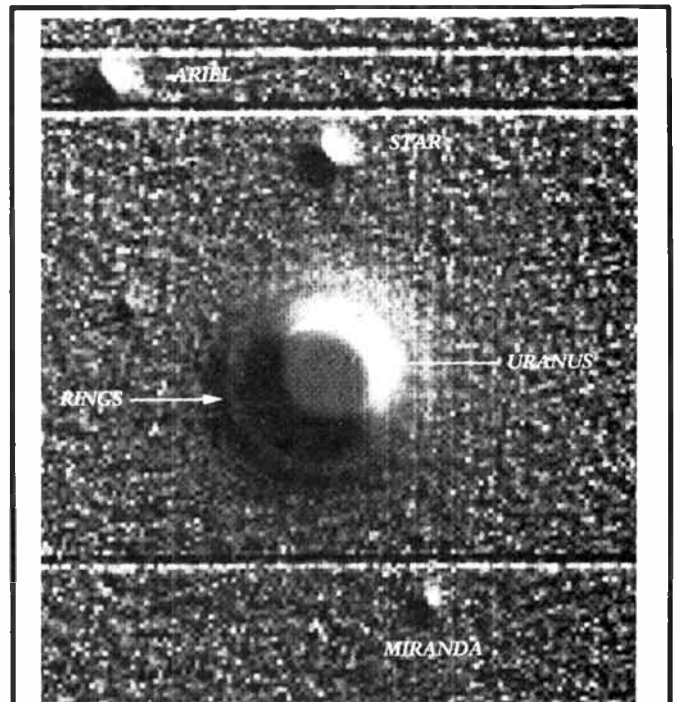
Apart from the huge array of information available on Viatel, with everything from stock exchange reports to video games, banking transactions can now be carried out (no, dear hackers, you cannot withdraw cash with it).

We're told that DSE staff are gambling thrillingly in the aisles (the press release said they are "extremely excited") about their decoder and they believe it will considerably lessen the workload of the householder and business user. We can but agree. Ask for catalogue number X-9700 at any Dick Smith Store. The price is \$499.

## Mobile radio solves 'phone shortage in China

Philips' first mobile automatic telephone service (MATS) system is now in service in Beijing, a city of 8 million people covering an area of 1700 square kilometres. The MATS system has been installed for the use of the Beijing Power Supply Bureau.

The present telephone system is very limited in China and mobile maintenance units do not



## SEE CLOSE-UP IMAGES OF URANUS

As from 7 December, visitors to the CSIRO Visitors Centre at Parkes in NSW have been able to see images of the Planet Uranus being recorded and transmitted back to Earth by NASA's Voyager II spacecraft.

The signals received by the telescope are beamed to the USA for processing and then returned (within minutes) for display to the public at the Visitors Centre. The service will continue into February 1986 and should be available for most days during this period while the telescope is tracking the spacecraft.

Currently the images show Uranus as a white disk with some darkening around the edges and a vague hint of surface features. Some of the planet's moons are also faintly visible.

Nine dark rings were observed to encircle Uranus in 1977, as the planet passed in front of a distant star. The picture here, courtesy of NASA, is the first clear photograph of the rings, from an observatory in Chile, acquired with an electronic camera and computer processed. Some of the moons are shown, too. (Picture by R. J. Terrile and B. A. Smith.)

The Parkes Radiotelescope, linked to NASA's tracking station at Tidbinbilla, is a prime receiving station for the Voyager mission.

have access to conventional call-box facilities, so it was necessary for the city to provide their own system for Beijing's maintenance and service crews.

The system provides dependable communication between the Beijing Power Supply headquarters and remote sites, and was a co-operative effort of several member companies of the worldwide Philips Group; Philips Hong Kong handled the

negotiations, Philips Communication Systems of Australia delivered the mobile telephone equipment, and Te Ka De of West Germany provided the system's infrastructure.

Future MATS systems, scheduled for installation later this year in the Kuizhou and He Nan Provinces, will again provide Philips with the opportunity to work closely on this important development. ▲

# Troubleshooting vehicle electricians with your multimeter

Roger Harrison

Here's a guide to locating faults in any vehicle electrical system using a multimeter.

PERHAPS THE MOST IMPORTANT TOOL that can be used in troubleshooting vehicle electrical systems is the multimeter. The basic multimeter measures voltage, current and resistance. More elaborate multimeters might include such measuring functions as frequency and temperature, diode tests and 'beep tone' continuity test.

Automotive multimeters have been around for years. These have had various applications and capabilities and many models available over the years have been ruggedly built to withstand the 'knocks' they'd receive in normal use. However, modern vehicles now contain a great deal of electronic circuitry for which such meters were never designed. Some of the older meters (and some new types, too) employ a 9 V battery to power the resistance function and this can destroy some sensitive electronics in modern vehicles.

## Meter considerations

The sort of multimeter commonly seen in the past was the analogue type with a meter having a needle moving over a scale to indicate the quantity being measured. In recent years, digital readout multimeters have become available. In general, they provide greater accuracy and are less likely to damage sensitive electronics as they employ a lower voltage battery to drive the resistance measurement.

However, where you need to see an increase or a decrease in a reading, digital displays simply show changing numbers that make it hard to tell what's happening. The more sophisticated digital multimeters (DMMs) incorporate an analogue scale in addition to the digital readout, generally in the form of a 'bar' beneath the main display. Some types also incorporate a handy feature called "display hold". This 'freezes' the meter display until you're ready to look at it. Many also incorporate a 'beeper' on the continuity test function that sounds an audible "beep" when testing for continuity of joints, short circuits, diode tests, etc.

If you are looking to purchase a multimeter, then the best guide is to buy the most expensive model you feel you can afford that gives you the functions and features you require. If you're unsure about exactly what you want, buy a lower cost model as a 'trial unit'. Using it will teach you more about what sort of instrument you want.

## Think first

When troubleshooting electrical systems, it's important to use a logical process of deductive reasoning to arrive at the source of the trouble. This process is most important since you can't see inside or dismantle the majority of electrical components in a vehicle to tell whether they're functioning, as you can with mechanical devices.

Consider the symptoms first. The real problem may actually exist in one system while the symptoms you're seeing appear in another. Deduce the system affected from the symptoms presented. Jumping to conclusions can be time-wasting and expensive. Using well thought out and organised checks you can usually determine the source of the problem first time. Work backwards, from the symptom to the fault.

Remember, the system functioned correctly at one stage — operating in a particular manner — the object is to return the system to that condition.

## Types of measurement

When fault-finding in any electrical or electronic system, you measure three fundamental parameters:

voltage,  
current, and  
resistance.

Probably the easiest measurement to make, and often the most useful, is voltage. You need to answer these questions:

- Is voltage present?
- What is the voltage reading?
- What is the voltage drop across a component?

The presence of voltage tells you that the wiring and components are delivering electricity supply to the component you're testing.

The voltage reading tells you whether the proper voltage is arriving at (or present on) the component.

The voltage drop across a component tells you how much of the voltage is either available for the component's operation or how much it is consuming.

For example, a relay has 12.8 volts present on the 'input' side and 9.2 volts present on the 'output' side. The voltage drop (the difference between the input and output side) is 3.6 volts. If it's a 12 volt relay (that is, requires a nominal 12 V across it to operate), then there's a fault. Here, it's clearly on the output side. Remember that wires and connections can also be considered 'components' and may experience voltage drops if faults exist.

## Separating the systems

Vehicle electrical problems may be divided into several categories according to the system presenting problems. I'll remind you here that the real problem may exist in one system but symptoms appear in another.

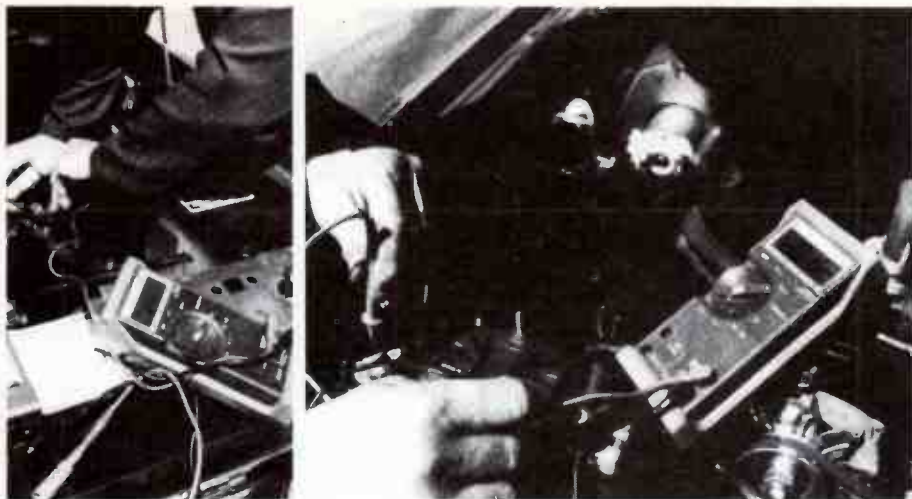
The vehicle electrical system can be broken into five categories:

- 1) The battery charging system.
- 2) The starting system.
- 3) The ignition system.
- 4) Lighting and accessories.
- 5) The cooling system.

For a variety of reasons, many vehicle owners wait until one or other of the systems fail totally. As often as not, the vehicle just "won't start". Some failures result in chronic problems of some sort, like a repeatedly discharged battery, hard starting when hot, etc.

Always, the first step is to decide which system is most likely at fault, then proceed with your tests using the multimeter. Table 1 sets out the five systems and the type of measurements you may need to make, in order of importance in the columns from left to right, starting with "voltage presence & level".





**YOUR FIRST CHOICE  
FOR FEATURES,  
QUALITY & VALUE**

FLUKE 73	FLUKE 75	FLUKE 77
Analog/digital display	Analog/digital display	Analog/digital display
Volts, ohms, 10A diode test	Volts, ohms, 10A mA diode test	Volts, ohms, 10A mA diode test
Autorange	Audible continuity	Audible continuity
0.7% basic dc accuracy	Autorange range hold	Touch hold function
2000+ hour battery life	0.1% basic dc accuracy	Autorange range hold
3-year warranty	2000+ hour battery life	0.3% basic dc accuracy
	3-year warranty	2000+ hour battery life
		3-year warranty
		Multipurpose holster

FROM THE WORLD LEADER  
IN DIGITAL MULTIMETERS.



See the 70 Series at leading electronics stores  
or contact us for data

**ELMEASCO**  
Instruments Pty. Ltd.

<b>NEW SOUTH WALES</b> 15 McDonald Street MDRDLAKE P.O. Box 20, CONCORD NSW 2137 Tel (02) 736 2888 Telex AA25887	<b>VICTORIA</b> 12 Maroonah Highway RINGWOOD P.O. Box 623 RINGWOOD VIC 3134 Tel (03) 879 2322 Telex AA30418 ELTENT	<b>QUEENSLAND</b> Tel (07) 369 8688 <b>S AUSTRALIA</b> Tel (08) 344 9000 <b>W AUSTRALIA</b> Tel (09) 481 1500
--	--	--

System/Component	Measurement Type			
	VOLTAGE PRESENCE & LEVEL	VOLTAGE DROP	CURRENT	RESISTANCE
<b>CHARGING SYSTEM</b>				
Alternators	•		•	
Regulators	•			
Diodes				
Connectors	•	•		•
<b>STARTING SYSTEM</b>				
Batteries	•	•		
Starters		•	•	
Solenoids	•	•		
Connectors		•		•
Interlocks	•			
<b>IGNITION SYSTEM</b>				
Coils	•			•
Connectors	•	•		•
Condensors				•
Contact Set (points)	•			•
Distributor Caps				•
Plug Wires				•
Rotors				•
Magnetic Pick-up	•			•
<b>LIGHTING &amp; ACCESSORIES</b>				
Compressor Clutches	•		•	
Lighting Circuits	•	•	•	•
Relays	•	•		•
<b>COOLING SYSTEM</b>				
Connectors	•	•		•
Fan Motors	•		•	
Relays	•	•		
Temperature Switches	•	•		
Radiators				•



Fluke manufacture a range of DMMs that are ideally suited to vehicle troubleshooting service. Their '20 series' offer fuses on all current inputs and optional high visibility yellow cases. They are ruggedly made, have analogue bargraph displays beneath the LCD readout and the 25 and 27 models have a 'touch-hold' display feature. Elmeasco distribute Fluke Instruments in Australia.

## Batteries

Charging system faults often present as a "no-start" problem. The battery will have become discharged and the starter won't crank the engine. The first step is to test the battery and charge it if necessary. You can do a hydrometer check too, if it's not a 'maintenance-free' type battery. Because you can't check the electrolyte in a maintenance-free battery with a hydrometer, measuring the open circuit voltage is the simplest way to test the charge.

Using a multimeter to test a conventional battery saves you the time and mess of dipping into the battery acid. A load test should also be performed; it's the only reliable way to test a battery's performance under actual conditions. Turn on the headlights, the battery voltage should drop by less than one volt.

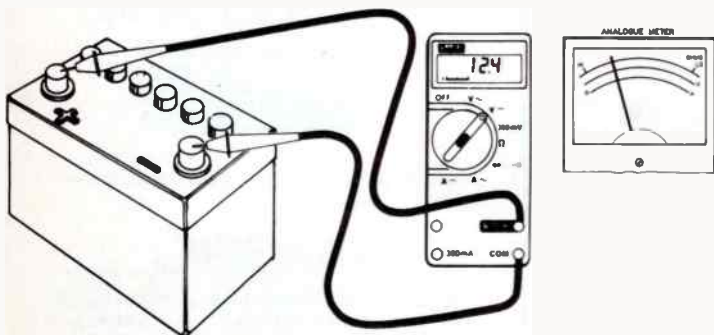


Figure 1. Put the meter probes directly on the battery terminals to measure battery voltage. A fully charged battery should show at least 12.4 volts without a load.

## Alternators

Alternators should maintain enough voltage to keep the battery charged even while running at its rated amperage output. Check the alternator output voltage at the battery terminals with the alternator loaded to its rated output. Use a carbon pile (see panel) across the battery to load the alternator.

You can also test the alternator using an inductive current clamp meter accessory. See Figure 2.

Poor performance, particularly when the alternator is heavily loaded, can be caused by worn brushes. The condition of the brushes can be determined by measuring field current (as in Figure 2).

Failing being able to do current checks, proceed to the next step.

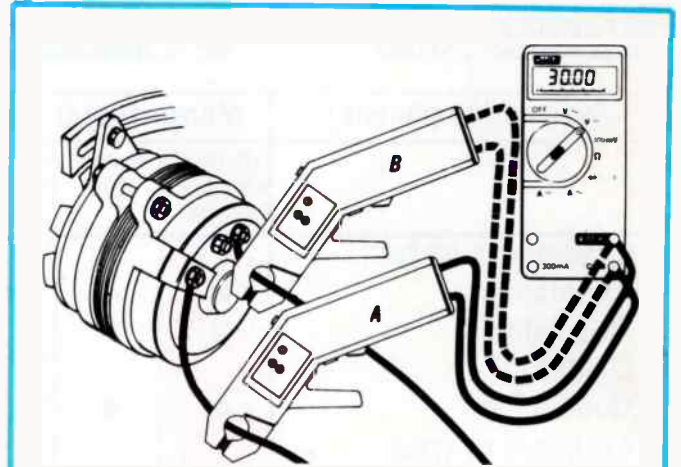
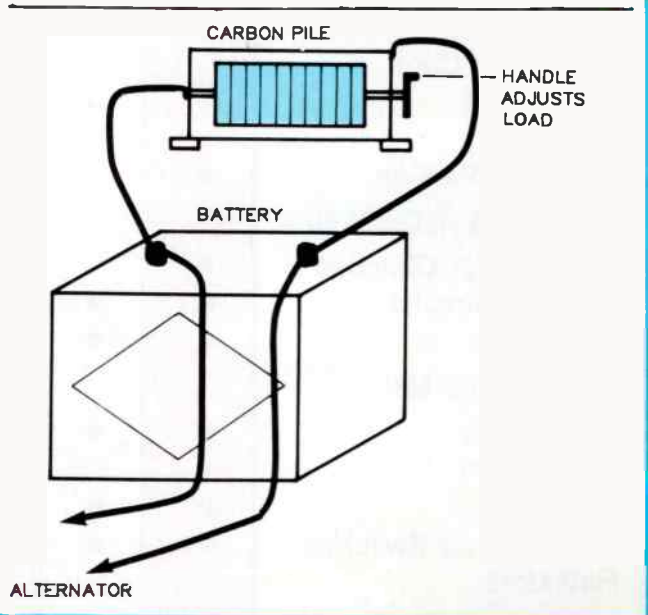


Figure 2. If your meter can use a 'current clamp' accessory (which allows current measurement without having to open a cable), then it's ideal for measuring alternator output current and field current.

To measure alternator performance, set the engine running at about 2000 rpm and load the battery, using a carbon pile (see panel), to the alternator's rated output. Put the clamp on the alternator output wire ('A'). If performance is not up to spec, check the alternator.

Field current can be checked in the same manner, only put the clamp on the field wire ('B').

Note that a current clamp is also useful for checking starter current draw.



# "Can you see the changes Philips Components have made to car manufacturing?"



For something that has so radically changed our lifestyle, the motor car has undergone few really fundamental changes. Its faithful reciprocating combustion engine, for example, is mechanically the same as it was when man was first learning to fly.

Yet one true automotive breakthrough has been the application of modern electronics. Fuel injection systems that "read" the supply, the load and adjust to the demand. Engine management systems that continually monitor and rectify. Consoles that "speak up" about anything from brake failure to seatbelts not fastened.

And while it's true we once got by without this much help, it's amazing how quickly we come to rely on it. Which soon makes products without advanced electronics seem like something's missing.

As a car manufacturer or any "other" manufacturer, there's every chance your products or processes are already affected by the application of this modern technology. Or soon could be. So whether you do it first or second could have a lot to do with what you do next.

Talk with the people who make electronics in Australia... Philips Elcoma. Find out the newest technology applicable to your products and processes, from our worldwide access. The results may surprise you.

Call Philips Components to discuss the changes you have in mind to your manufacturing technique:

Sydney 439 3322 Melbourne 542 3333  
Adelaide 243 0155 Perth 277 4199  
Brisbane 44 0191

*We make electronics in Australia*



Electronic  
Components &  
Materials

**PHILIPS**

the UN 268



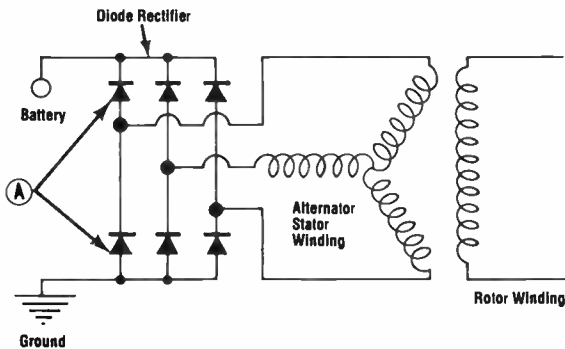


Figure 4. Typical alternator circuit. Note that both diodes in any one of the three circuit 'legs' must be shorted for the DMM to indicate a short. You'll have to dismantle the alternator to find any culprits.

in the starter cable will cause a two volt drop in voltage at the starter. 0.01 ohms is too little for all but the most expensive and sophisticated ohmmeters to measure, but measurements of voltage drop will indicate where there is resistance.

A DMM featuring the 'display hold' function will record the voltage drop for you while you're inside the car turning the key. You can look at the display when you come back to change the test points. Since this function usually ignores zero readings, it will retain the voltage drop on the display after you have stopped cranking the engine.

This procedure is helpful on components and connections except solenoids, which read battery voltage if you measure across them when the engine is not being cranked.

Total voltage drops should not exceed the following:

- 0.2 V Wire or cable
- 0.3 V switch
- 0.1 V ground
- 0.0 V connections

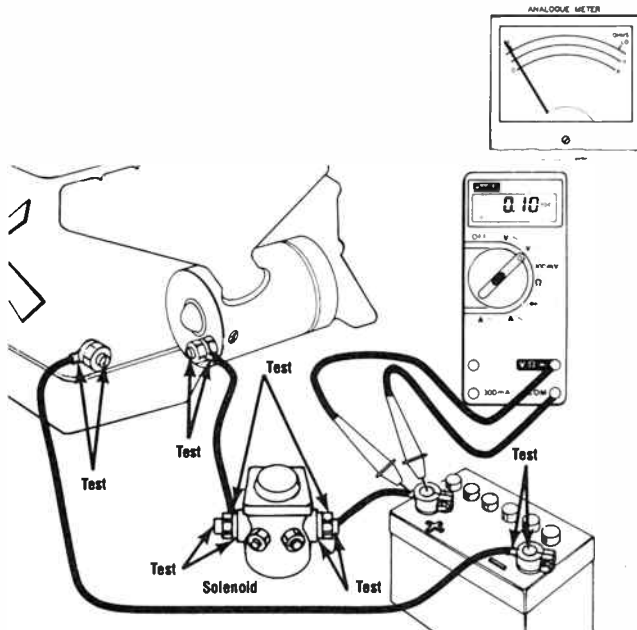


Figure 5. Voltage drop tests. Measuring the voltage drop across terminal assemblies, solenoids, etc shows up starter system faults. Do this while cranking the engine. Measure the drop across the battery post and connecting cable, across the solenoid posts and wires that attach to them, and across the solenoid itself. Also check the connection on the starter and the ground strap connection to the engine block.

# Compact DMM's...

...with real testbench performance

Philips Series 18 DMMs give you a magic combination – no-compromise testbench features and performance, packaged in a choice of three compact, easily portable instruments that are always handy for lab, workshop or field use.



Our range of three models lets you select exactly the functions you need for every application and environment.

## PM 2718

min/max, auto data  
hold, 100 kHz RMS AC,  
0.05% DC

## PM 2618

electronic calibration,  
200 kHz counter, 0.3%  
bargraph and 10 MHz  
logic view

## PM 2518

RMS AC,  
direct temperature,  
dB and relative  
measurements

Contact your local Philips organisation  
or:

SYDNEY: Box 119  
North Ryde 2113  
Tel. (02) 888 8222  
(Toll free (008) 22 6661)  
MELBOURNE: Locked bag No. 5  
Oakleigh South 3167  
Tel. (03) 542 3600  
(Toll free (008) 33 5295)



# PHILIPS



Philips Test and Measurement offer three compact DMMs — the '18' series. The PM2618 features an analogue bargraph, frequency counter and logic pulse view display, while the PM2718 has a display hold function. They can be obtained with a 'backlite' feature that lights-up the display automatically in poor light conditions.

## The ignition system

Bad coils can often be found by measuring the initial resistance. The primary should have a very low resistance, and the secondary windings a somewhat higher resistance. To get the actual figures for a specific coil, check the manufacturer's specs. It's often a good idea to check the coil when it's cold as well as when it's hot. Many analogue meters cannot effectively show resistances under 20 ohms, but DMMs come into their own in this area. See Figure 8.

Check for leaking condensers with the ohms function. As the condenser charges up, the resistance should increase to infinity. Any other reading indicates that you should replace the condenser. If the condenser is in place, make sure the points are open. See Figure 9.

Plug wires should be checked if you suspect that there may be a problem or if they're more than a couple of years old. Look for the year and quarter number printed on the wire; however, not all wires are dated. Remember that the wires would have been installed sometime after the date of manufacture.

The resistance of the plug wires depends on length and is generally in the order of 1000 ohms per foot (300 mm) for resistance leads. Wire leads will just be a few ohms.

Check for corrosion or arcing at the rotor tip; they can cause problems. Also check for high resistance between the centre contact and the rotor tip. Remember some foreign rotors have a resistor here or a rev limiter in the rotor. Check your findings against manufacturer's specs.

You have to approach electronic ignition systems differently. Often it's difficult to determine which of the compo-

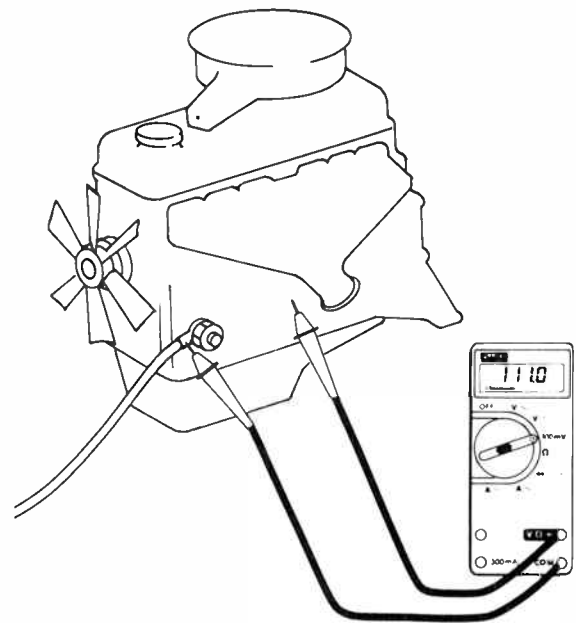


Figure 6. If you have a meter with a 'display hold' facility, voltage drop checks are much simplified. Clip the leads across the connection to be measured, select the function and set the meter to read millivolts (mV). Crank the engine and the meter will 'hold' the reading until you return.

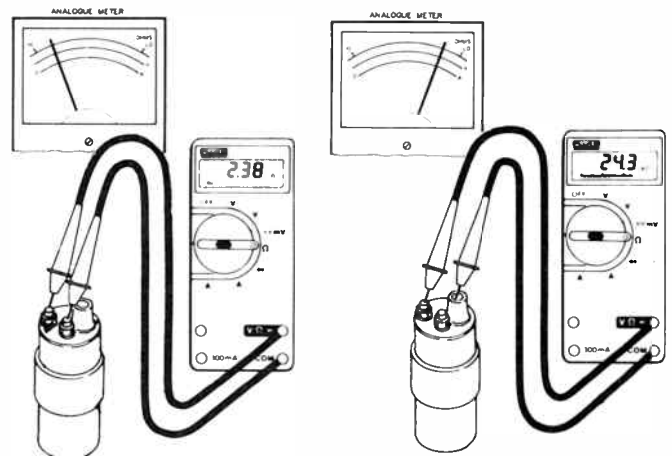


Figure 7. If you suspect the ignition coil, check the resistance of the primary and secondary, both when it's cold and when it's hot. The primary winding should show a low resistance at all times, the secondary a relatively higher resistance. The manufacturer's specs will indicate typical values.

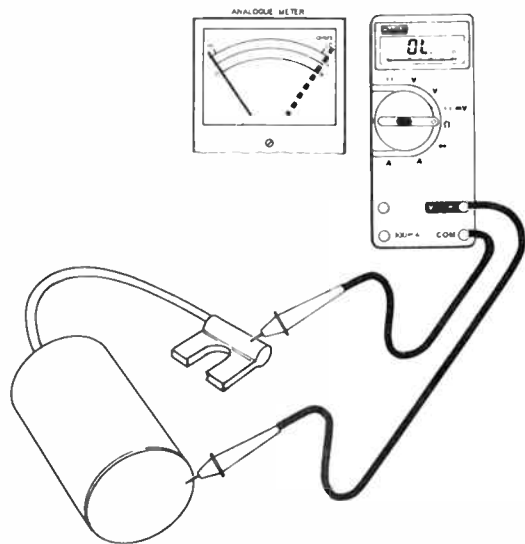
nents in an electronic ignition system is at fault. By elimination you can isolate the trouble to either the electronic module or the distributor's inductive pickup.

Check the proper operation of inductive pickup and reluctor wheel by measuring the output pulses. (NOTE — this procedure will not work on Chrysler and other Hall-effect ignitions.) Check for pulses coming from the magnetic pickup as shown in Figure 10.

## Current drains, shorts and bad grounds

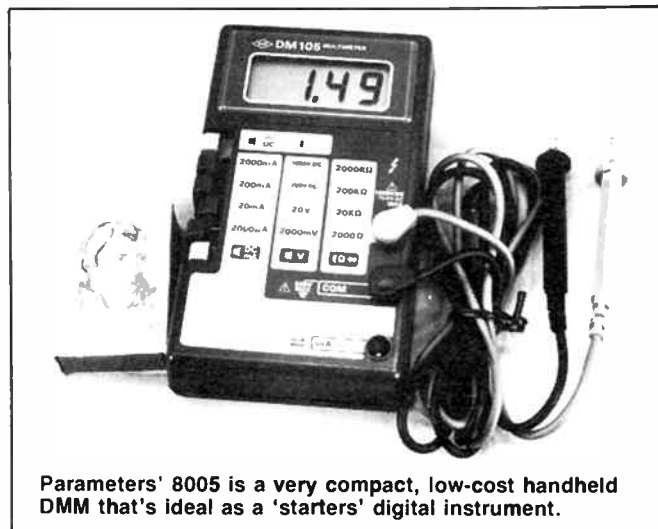
Current drains, shorts, and bad grounds are the cause of many problems. The cause of the problem often seems to have nothing to do with the symptom. But, using a DMM you can find the cause quickly without using a whole box of fuses.

Current drains that run the battery dead overnight are often referred to as shorts, although they may not actually be short circuits. Shorts that blow fuses can be found using the same trouble-shooting techniques used to find current drains, even though the symptoms are different.

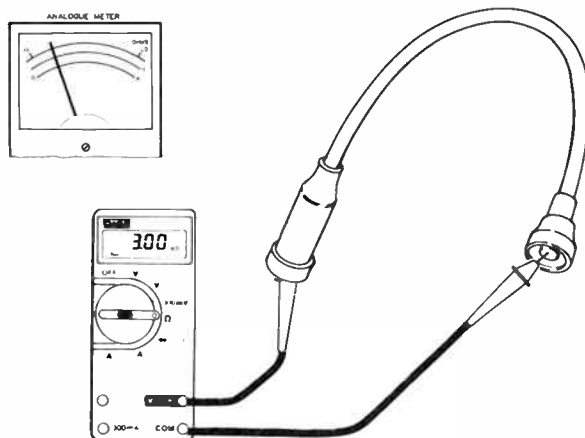


**Figure 8.** Check condensor leakage with your meter's resistance range. First momentarily short the condensor's two terminals to dissipate any residual charge, then attach the probes. Initially, it will show zero resistance, quickly rising to infinity. Any other indication shows you should replace the condensor.

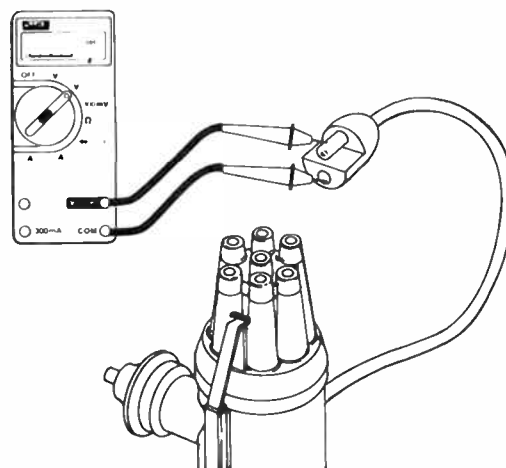
If you make this measurement with the condensor 'in situ', make sure the points are open.



Parameters' 8005 is a very compact, low-cost handheld DMM that's ideal as a 'starters' digital instrument.



**Figure 9.** Plug wire resistance should measure around 1000 ohms per foot (300 mm) for resistive-type ignition wire. check manufacturer's specs if you're unsure. Some high energy ignition system cables are good at 30 000 ohms per foot, note.



**Figure 10.** If your car is 'point-less', you can check for pulses coming from the magnetic pickup. To do this, connect the probes across the pickup output connections and set the meter to a low dc voltage range. When the engine is cranked, the readout will pulse (on DMMs with a bargraph). If you can't detect pulses, it's likely the reluctor wheel or inductive pickup assembly is faulty. (This test will not work on Hall-effect ignition systems).

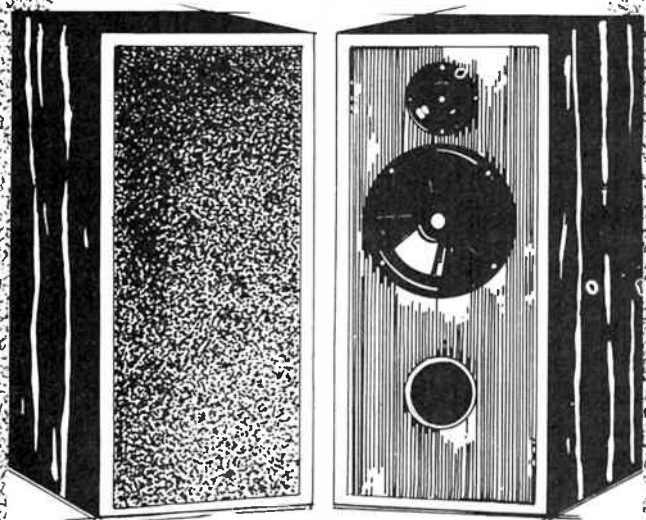


This low-cost multimeter from Dick Smith Electronics (Q-1022) is typical of many analogue-type multimeters, but features a buzzer for continuity testing.

**CAUTION** — To avoid blowing the meter's fuse, use the 10 amp input until you are sure that the current draw is less than one amp. Do not crank the engine or operate accessories that draw more than 10 amps. You could damage the meter, possibly beyond repair.

To check the entire system for current drains connect the multimeter in series with the battery. Set the meter to read 10 amps or more. Once you determine the current draw is less than an amp, switch the meter's range switch to a lower range and place the test loads in the meter's low current range and jacks. The meter will then show the total current drain.

# DAVID TILBROOK HAS AROUND \$800 TO GIVE YOU, AND A SUPERLATIVE 2-WAY SPEAKER AS WELL!



We're talking about the exciting new David Tilbrook designed speaker kit which uses VIFA's high performance drivers from Denmark. His 2-way, digital-ready 100 Watt capable masterpiece.

The name Tilbrook is synonymous with brilliant design and performance characteristics and this new system keeps the legend alive and well. The magazine 'The Australian Electronics Monthly' - where David is Project Manager - published full details of the design in their August issue. Already there has been considerable interest and many speakers have now been built with superb results.

You'll save around \$800 when you hear what you get from this system when compared to something you buy off the shelf with similar characteristics. If you compare its performance to fully imported, high priced, speakers from Mission, Heybrook, Monitor Audio, Bang & Olufsen and many others, you'll see that they too use these VIFA speakers.

This kit of 2-P21WO Polycone Woofers and 2-D25TG-55 Ferrofluid Cooled dome tweeters with Polymer Diaphragms, is available for \$350. Cross-overs, cabinets and loudspeaker stands are also available.

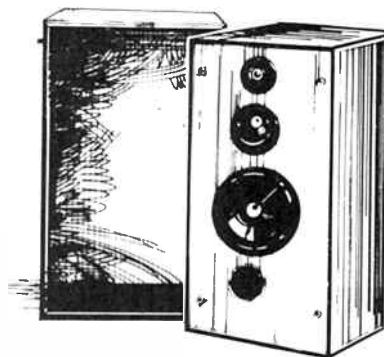
For further information and a reprint of the full details of the Tilbrook project, please telephone or write to the Sole Australian Distributors, who can also give you the name and address of your nearest stockist.

Stocked by Jaycar Electronics and leading hi-fi and electronic stores.

# vifa

**Sole Australian Distributor:** SCAN AUDIO PTY. LTD.,  
P.O. Box 242, Hawthorn 3122. Telephone (03) 429 2199.  
**Queensland Distributor:** Queensland Stereo Visual Supply.  
Telephone (07) 265 7945.

# A GREAT REFERENCE FOR (AND BY) DAVID TILBROOK



They compete with \$2,500 Reference Monitors - but can be built for a third of the price!

We're talking about the VIFA 3-way Reference Monitor designed by David Tilbrook - following the incredible success of David's 2-way AEM-6102 VIFA based design published in August. The 2-way kit has been sold in staggering quantities by hi-fi stores and electronic shops throughout Australia, where they can be heard outperforming 'well known' imported brand names costing two to three times as much!

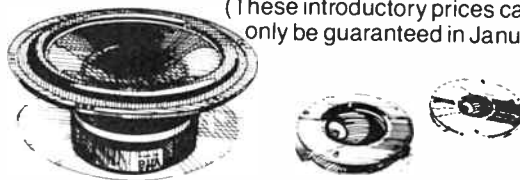
Now David Tilbrook has done it again, this time with the 3-way VIFA design AEM-6103. Never before has it been possible to get such great value in kit speakers; the reasons being that there is no 25% import duty, no 30-35% freight into Australia, no high freight costs within this country itself, no 30% sales tax and no profit margins added to all these links of the chain which are involved in importing fully assembled speakers.

The 3-way AEM-6103 sounds like two to three times what you'd pay for in a recognised brand name (which may even be using VIFA drivers), and these might well be using inferior cross-overs and cabinets to save cost.

Today, we can offer you the drivers for the 3-way at the following prices:

**2 pcs D19DT Tweeters \$38.00 each.**  
**2 pcs D75MX Midranges \$89.00 each.**  
**2 pcs P25wO Woofers \$149.00 each.**  
**2 pcs Factory Built X-overs \$119.00 each.**

(These introductory prices can only be guaranteed in January.)



**Dealers - Sydney:** Jaycar Electronics.  
**Melbourne:** Radio Parts.

**Brisbane:** Queensland Stereo Visual Supply.  
**Adelaide:** International Sound.

For further information, please contact the Sole Australian Distributor:  
**SCAN AUDIO PTY. LTD.**  
52 Crown Street, Richmond 3121.  
Telephone (03) 429 2199.



## Budget cassette deck has host of features

From the Falk Electrosound Group, we have received a lengthy press release on the new NAD6130 cassette deck. Styled in the traditional NAD manner with muted grey tones and the minimum of controls, the NAD6130 should have wide appeal.

This is a 'budget price' cassette deck but claims to be extremely high quality. NAD's philosophy is stated as "reducing external frills to the minimum whilst putting the manufacturing costs into the electronics".

Most of the NAD manufacturing budget is invested inside — on low noise circuitry, a high precision, low flutter tape transport, and a hard permalloy record/play head that produces low distortion recordings over a wide dynamic range. This adds up to a level of performance, in

both recording and playback, that normally is found only in more costly tape decks, NAD claims.

The NAD 6130 features include: • Dolby B and C noise reduction • increased headroom • permalloy record/play head for low distortion and high dynamic range • instant release pause control • peak reading LED meters.

The price of all this — just \$359! Details from **The Falk Electrosound Group, 28 King Street, Rockdale 2216 NSW. (02) 597 1111.**



## One-touch cassette recorder

Sanyo has introduced the M1011, a compact cassette recorder featuring one-touch recording. Particularly suited for outdoor dictation, the unit is designed for one-hand operation, giving users a free hand to carry out other tasks.

Features of the M1011 include pause control for easy editing of tapes, cue and review functions for easy location of recorded selections, and auto stop at the end of the tape in play and record modes to reduce wear on tapes and mechanisms.

Other benefits of the M1011 are the built-in condenser microphone which provides convenient recording in any location, with an automatic level control (ALC) to assure even recording levels.

The M1011 operates on ac (with optional adaptor) or dc



power (through external 6 V input jack for four AA batteries).

Available in an attractive black and silver finish, the M1011 is priced to sell for around \$59.95. For further information, contact Mr Wally Fabiszewski at Sanyo, on (02) 439 2411.

## NAD 20 loudspeakers

The new NAD 20 loudspeaker embodies the same design philosophy that has won worldwide praise for NAD electronic components. The essence of this approach is to concentrate on sonic excellence and real performance, says NAD.

The NAD 20s are designed and manufactured by



Braun/ADS in West Germany. ADS woofers are noted for exceptionally quick and articulate transient response while their soft dome tweeters produce crisp, airy, extended, peak free highs, it is claimed.

Special construction techniques are used so that the drivers have an exceptionally small voice coil gap. The cone of the woofer is progressively tapered in thickness which prevents "cone break up" to eliminate coloration. The crossover network is very carefully designed to maximise performance and sonic purity.

The NAD 20 offers extended response, fast, accurate transient tracking, wide dynamic range, precise stereo imaging, a graceful silhouette and all for a modest price. The NAD 20 loudspeaker offers a great choice for the discerning listener who wishes to take maximum advantage of digital recordings, says NAD.

Available from **Falk Electrosound, 28 King St, Rockdale 2216 NSW (02) 597 1111**

## These diamonds are forever?

Following the success of its original high performance "Diamond" speakers, Wharfedale is now introducing a new Mark II version, known in Australia as the "Super Diamond"

Considerable research and development effort was applied in improving the diminutive speaker system, awarded the 1984 Loudspeaker of the year, Category 1, by the Federation of British Audio.

Wharfedale used its laser and computer-assisted design technology to research drive units and crossovers and make three important changes to the original design of the Diamond. These include use of a "build ring" for precision driver assembly, increase of power handling to 100 watts, and a modified crossover.

To defy the normal mathematical relationship between cabinet size, efficiency and bass output, high performance components and materials are used.

The new crossover board uses the original components, but by reducing the number of earth

returns within the board, information retrieval has been increased, the makers claim.

The speakers feature the original two-way reflex design, a reflex port firing rearwards instead of the normal forward-facing variety. This design allows the speakers to be mounted on a shelf or stand close to a wall, as opposed to other small speakers which are designed to be positioned well clear of any room boundaries, Wharfedale say.

To improve reproduction of low frequencies, the patented build ring found in the 708 and 508 was incorporated into the 110 mm mineral-filled homopolymer polypropylene bass-mid unit.

A 20 mm high-quality plastic dome tweeter, based on Wharfedale's TSR 102.2 model, is used with a cone made of mineral-filled homopolymer (MFHP), a material pioneered by, and exclusive to, Wharfedale.

The Super Diamond is distributed in Australia by NZ Marketing Pty Ltd, 553 Pittwater Road, Brookvale 2100, and you get all this for an astonishing \$349 or thereabouts.

# The Great business offer from Microbee



## THE 128K SMALL BUSINESS COMPUTER

Microbee Small Business Computers are already providing invaluable help to thousands of Businesses around Australia, indeed around the World. It would seem that there are few professions or areas of commercial endeavour that cannot be streamlined or made to be more "accountable" with a Microbee Computer.

### Butchers, Bakers, etc.

Users range from publishers to pathologists, even car yards are finding the Microbee Small Business System the cost effective technology tool that keeps their records straight, their correspondence in order, and keeps them in touch with the fast moving world of Data Communications and Videotext Services.

## SPECIAL OFFER 'Living Letters Package'

The Complete Word Processor with WordStar Pro Pack and DP100 Printer

**\$1995**

Inc. Sales Tax



## The Software You Need

With the Microbee's now famous Bundled Software and CP/M operating system most routine computer functions are catered for without spending another cent, but it is highly likely that it is in the area of specialist applications software that Microbee scores most points. With so many third party software supplies able to provide specific solutions at realistic costs that don't in themselves create problems (check the prices of software to run on so called Compatibles).

### User Friendly Interface.

Every Microbee Small Business System has its own user friendly 'B-Shell' which allows the easy choice of software by simple one finger selection of self explanatory ICONS. A comprehensive Help system is supplied and 'housekeeping' functions are simplified.

### Australian Guaranteed

Built to exacting control standards and World class quality the Microbee System is particularly robust: remember the Microbee was first developed for use in schools, and in fact the same machine is in extensive use in schools, both in Australia and overseas.

## The Complete Business Package

The Microbee Small Business System comprises:

- Microbee 128K Computer
- Dual 400K 5.25" Disk Drives
- High Resolution Monitor
- DP100 Dot Matrix Printer
- Cables and full set of manuals plus

### Bundled Software

worth hundreds of dollars including— WordStar/Mailmerge 3.3, Microsoft Basic, Microsoft Multiplan, MicroWorld Basic, Telcom Communications Package, Full range of support utilities, Comprehensive Training Guides and Tutorials, A complete library of manuals so you can easily and quickly gain the maximum benefit from your system is also included.

### The Price

For the complete Small Business System only \$2395 including Sales Tax.

As many of the Microbee Systems out there are used extensively for Word Processing with little need for Microsoft Multiplan, the new 'Living Letters Package' has no Multiplan or Microsoft BASIC. But it does have The Complete WordStar Package to bring life to your writing and considerable savings to your pocket.

## EXCITING NEW OPTIONS

As part of Microbee's Product Innovation Program, new releases which will shortly be announced include:

The DP100 NLQ or Near Letter Quality Printer.

The MB 7030 High Resolution (0.38 pitch) RGB Colour Monitor.

The MB 3010 Green Screen Monitor.

The ESE Economy RGB Colour Monitor.



# microbee

## computer

Designed and manufactured  
in Australia by  
Microbee Systems Limited

PHONE  
ORDERS ACCEPTED

bankcard

### *Microbee Technology Centres*

#### **New South Wales**

1 Pattison Avenue,  
Waitara, N.S.W. 2077  
Phone (02) 487 2711

2/956 Hunter Street,  
Newcastle West, N.S.W. 2302  
Phone (049) 61 1090

Koala Crescent,  
West Gosford, N.S.W. 2250  
Phone (043) 24 2711

#### **Microbee Education Technology Centre**

Unit 2, Eden Park Estate,  
31 Waterloo Road,  
North Ryde, N.S.W. 2113  
Phone (02) 888 9866

#### **Victoria**

50-52 Whitehorse Road,  
Deeppene, Vic. 3103  
Phone (03) 817 1371

#### **South Australia**

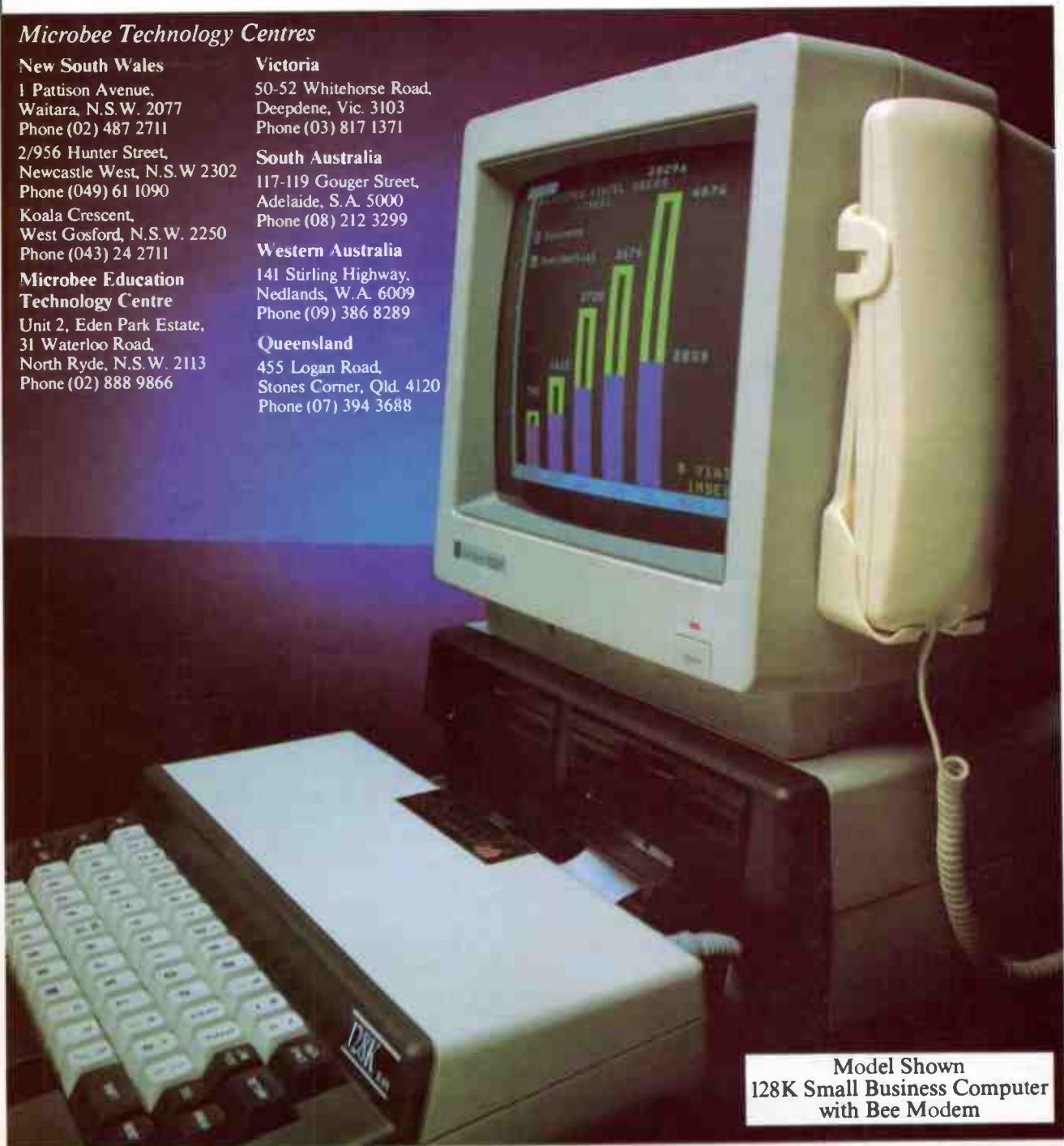
117-119 Gouger Street,  
Adelaide, S.A. 5000  
Phone (08) 212 3299

#### **Western Australia**

141 Stirling Highway,  
Nedlands, W.A. 6009  
Phone (09) 386 8289

#### **Queensland**

455 Logan Road,  
Stones Corner, Qld. 4120  
Phone (07) 394 3688



Model Shown  
128K Small Business Computer  
with Bee Modem

# Audiosound Laboratories' 'Motet' 8011A loudspeakers

Robert Fitzell AAAC

Having previously 'scaled the heights' of hi-fi – performance and costwise – this month we look at a pair of 'budget' loudspeakers from a local manufacturer.

IT IS PROBABLY a little unfair to follow our last review, the Nakamichi OMS-7 CD player, and one of the best input ends to the best of systems, with a loudspeaker which probably makes no claims to being a 'top-of-the-tree' output end on even middle of the road systems. However, until we all find that elusive end to the rainbow, once we have all sold our best crockery to fund the OMS-7 and appropriate connectors, we probably also have to look at just the type of loudspeaker the Motet 8011A purports to be for our den, kid's system or party speakers etc., with the few dollars that are left.

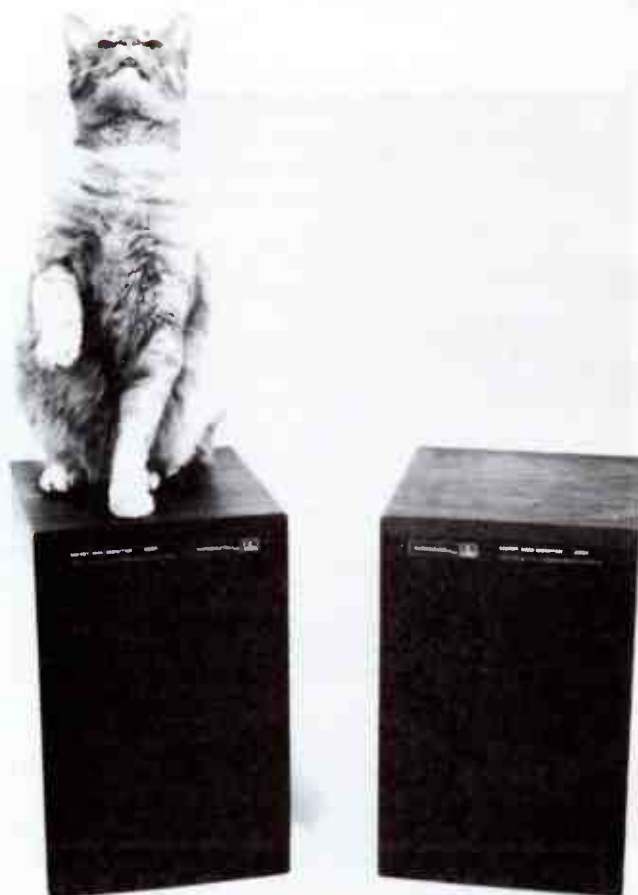
The Motet is a low-priced loudspeaker locally manufactured by Audiosound Laboratories at North Curl Curl in Sydney. It is their lowest priced unit. At \$295 per pair the units are priced to compete at the low end of the market and the old rule of "you get what you pay for" applies nowhere more so than in the loudspeaker marketplace.

## The basics

The Motet 8011A loudspeaker is a two-way loudspeaker using a 150 mm roll-surround bass driver (looking suspiciously like a Magnavox) crossed over to a 60 mm cone tweeter through a filter/equaliser. Apart from promoting it as a "sophisticated 7-element unit", no other details about the crossover are given. The cabinets are manufactured from plastic woodgrain finished particle board with a brown speaker cloth protector. Cable connections are made at recessed spring-loaded clips of adequate size to accommodate quite heavy cables.

The units are small at 370 mm high x 240 mm wide x 290 mm deep and weigh 7 kg each, but are by no means the smallest wide-range bookshelf unit on the market. Overall quality of construction is probably as should be expected from a unit at the low end of the market. My own experience with any items made from plastic veneered particle board is that the material is not likely to take hard wear at all and a bookshelf mounting is where they should stay. The "veneer" will hardly match your rosewood chiffonier or mahogany sideboard, but again it hardly should be expected to.

The use of the paper cone tweeter is a little unusual and



Audiosound freely admit that the performance is not up to the 25 mm domes that they use in most of their other systems. The penalties of the dome tweeter are loss of efficiency and higher cost, both of which are likely to make the loudspeakers less attractive to a purchaser looking for a simple system for a low power application. More importantly, I was surprised at the seemingly hasty assembly of the loudspeaker drivers in the cabinet. The drivers are fully sealed with a hard setting sealant, however almost all fixing screws to the drivers, and in fact on the rest of the box itself, were inserted at a variety of angles that suggested rather hasty assembly. The bass driver is slightly recessed so that the plane of the roll-surround is approximately flush with the baffle board, while the tweeter, being a relatively shallow unit is flush-mounted. Fixture of the tweeter is achieved by four astonishingly large protruding screws. The sides of the cabi-

REVIEW ITEM:	Loudspeaker
MANUFACTURER:	Audiosound Laboratories, 148 Pitt Rd, North Curl Curl 2099 NSW. (02) 938 2068
MODEL:	Motet 8011A
FORMAT:	Two-way sealed enclosure
PRICE:	\$295 per pair
SUMMARY:	A din for the den

net extend slightly past the baffle board, and this is worsened by the deep frame supporting the speaker grille cloth which extends further still. From a detailed acoustic viewpoint, the junction of the grille cloth frame, the protruding speaker sides and top and the baffle board is both complex and undesirable.

Together with the Motet loudspeakers the purchaser receives a small amount of supporting literature. This is aimed at the non-enthusiast and is quite useful. Audiosound have supplied loudspeakers for some years to the Australian Broadcasting Corporation and from the enclosed literature, the Motet is seen by them as a potential unit for use in schools and other similar applications. Whilst it is not all that clearly stated, the implication from the literature accompanying the loudspeaker is that Audiosound Laboratories give a transferable five year warranty on the loudspeakers. This is an excellent warranty, particularly for a low-priced unit and would be a great incentive to intending purchasers for schools and similar applications.

As Audiosound rightly claim they have been operating here for 15 years, so have shown the company stability necessary to backup a warranty of this length. As we all know, if a company decides to disappear, it is a little difficult to find someone else interested in meeting the warranty.

The Motet is given the statue of 'Mini Monitor' on the nameplate and in their literature, Audiosound have taken trouble to fire a few volleys over the bows of the "digital sound needs special equipment" brigade. At the end of our review of the Motet I would have to say I feel this status is a little misleading.

The usable (?) frequency response is stated by the manufacturer to be 50 Hz to 20 kHz, with objective performance being stated on the back of the loudspeaker as 60-18 kHz,  $\pm 6$  dB. Recommended amplifier power capacity is from 5 to 50 watts and the sensitivity stated to be 87 dB at 1 watt/1 metre. This gives a theoretical maximum level of 104 dB RMS at 1 metre from the speakers, or an expected level of music in a small room of up to 100 dB(A).

## Subjective testing

In listening tests I found the Motet disappointing. However, I found the box relatively free of the immediate colouration of which many similar low-priced units are so guilty, but the overall standard of performance I can only call lifeless. My acoustical analogy when listening to classical music source material is of being in the entry lobby to Sydney Town Hall when the concert has already started — the sound is simply coming from another room. This impression is almost certainly due to a colouration at the bottom end of the loudspeaker performance spectrum and a serious lack of high frequency performance. As I will mention later, the higher frequency deficiencies are so dominant that the colouration simply doesn't stand a subjective chance.

Consequently it is difficult to become involved in the music and for classical music, this is clearly not one to buy. On pop music the performance is considerably better, due primarily to the limited dynamic range, bandwidth and comparative lack of definition of this type of music when compared with orchestral sound. For pop music the speaker can sustain reasonable levels in smaller rooms, but again, is not suited to use in larger rooms where power requirements become high.

Subjectively, the unit seriously lacks treble, an impression which is well supported by the objective test results. Bass response is quite smooth but not as extended as the manufacturers' specifications lead one to expect.

For voice, there is a lack of definition which I suspect may

be related to deficiencies at the crossover frequency and above. With the low crossover frequency, most of the voice performance of the Motet is carried by the tweeter. For the market which Audiosound are seeking with the Motet, I feel the basic performance is there to build on but with quite a bit of work. With a superior tweeter, probably crossing over at a higher frequency, since the 150 mm bass driver clearly should have capacity beyond 1 kHz, the presence of the loudspeaker could be greatly enhanced. Bass and alignment of the loudspeaker could also probably be improved with little manufacturing cost increase to clean up the bottom end performance.

Having completed our listening tests which involve CD source, cassette tape and turntable source material we started testing for a little more objective evaluation of the Motet performance. At the end of our subjective performance we had already had the somewhat alarming experience of having one loudspeaker fail on us at quite reasonable listening levels.

For amplification, we were using a 100 watt per side stereo amplifier and so had to be cautious in the use of our output levels. The transient peak power handling capacity of the amplifier is obviously high and for reasonable listening levels through the Motet with wide dynamic range material. I found a real conflict between the power handling capacity of the speakers and the requirements for dynamic range of the source material.

## Impedance

Our first test was of the loudspeaker impedance with the results given in Figure 1. It can be seen that the nominal value for the loudspeaker of 8 ohms is really very arbitrary indeed and the impedance at high frequencies drops to as little as

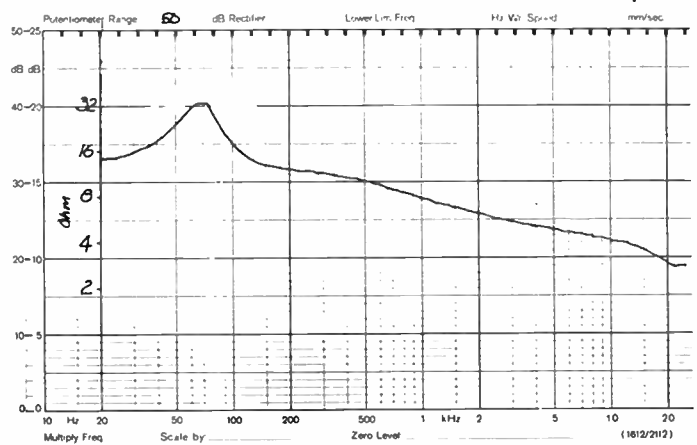


Figure 1. Impedance of the Motet 8011A across the frequency range 20 Hz to 20 kHz.

3 ohm. This rings warning bells for the use of this speaker, particularly with digital sources, since amplifier clipping could well see the end of the tweeters (a little ironic in view of our later experience during testing). The nominal figure of 8 ohms appears only to apply at 1 kHz and the bass driver impedance peak occurs at about 69 Hz. The Motet would certainly not meet the DIN standard of  $\pm 20\%$  impedance deviation over the working frequency range. On the positive side, the impedance curve is at least relatively smooth, so low impedance apart, the amplifier is probably going to be reasonably happy.

## Frequency Response

Frequency response of the Motet shows a number of problems, particularly, despite the claims with the crossover and tweeter unit. Response around the crossover is seriously down and shows that phasing needs some work done to get the best out of the system.

Near-field (50 mm) frequency response sweeps for both drivers (Figure 2) shows that potential response for each driver individually is good, the bass unit particularly so. The tweeter shows an undesirable peak at 12.5 kHz and a very rapid roll-off thereafter, but overall, is also up to the standard of many more expensive units. We still could get nowhere near the 20 kHz upper limit quoted for to the system however.

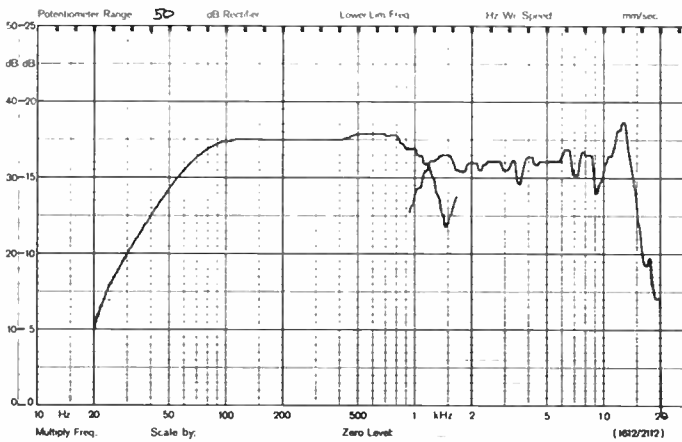


Figure 2. Near-field frequency response of the Motet 8011A.

Put together in the Motet box (Figure 3) the response is far from good. The dip in response at 140 Hz is a ground effect and, being an environmental effect, should be ignored. The dips at 1050 Hz, 2450 Hz and 3150 Hz just cannot be ignored, however. We did not have time to do any investigational work to establish the causes of the two upper dips. However, the box is very simply designed and has many points around each driver, described earlier, from which spurious reflection will occur.

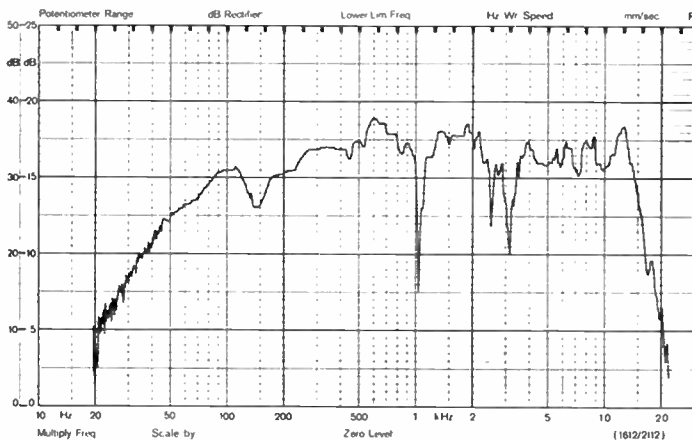


Figure 3. On-axis, free-field frequency response.

This has long been acknowledged as the cause of many performance anomalies at high frequencies, but again to be fair, to eliminate these reflections usually results in higher construction costs and unit prices. Testing of the tweeter alone at two metres on axis (Figure 4) again shows the same anomalies.

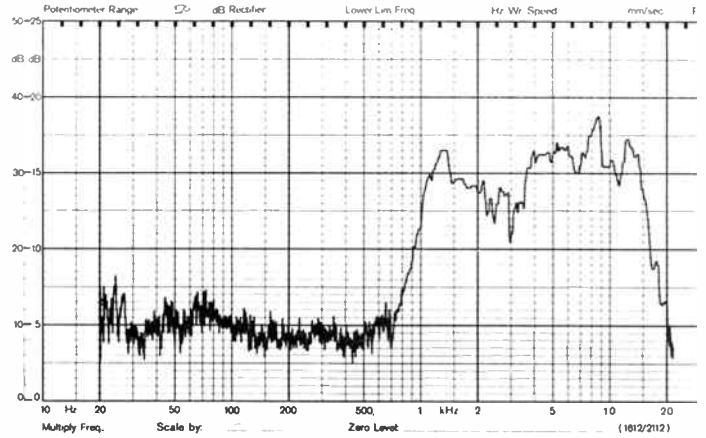


Figure 4. Tweeter response of the Motet, on-axis.

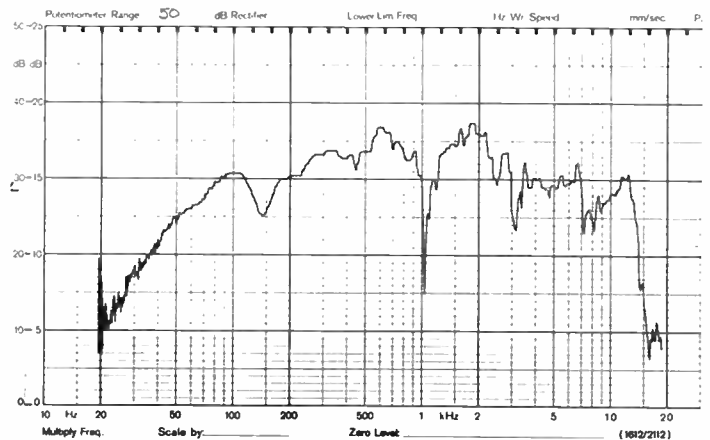


Figure 5. Frequency response of the Motet at 30° off-axis.

The major dip at 1050 Hz shows the claims for high performance of the crossover are not really justified and some more work here might see a much improved loudspeaker.

Our distortion tests were limited to 1 kHz and 10 kHz only. Results are given in Figures 6, 7, 8 and 9 and proved to be reasonably good. Apart from the 1 watt/1 m/1 kHz trace, these tests are of the tweeter alone, and since cone loudspeakers do tend to display relatively low distortion, the results are perhaps not surprising. The distortion products in Figure 6 are mainly those of the tweeter and not the bass driver.

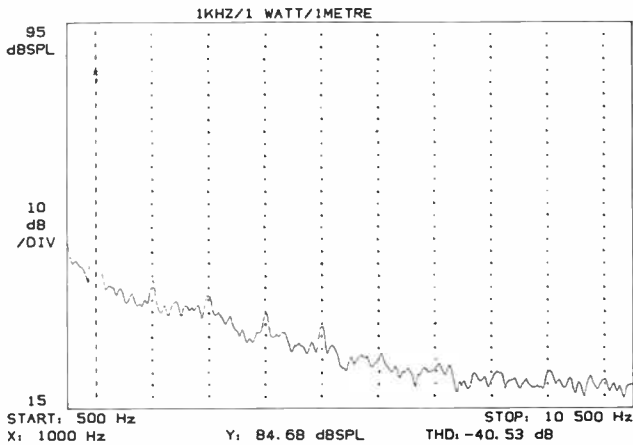


Figure 6. Distortion performance of the Motet 8011A, at one metre with 1 watt drive at 1 kHz.

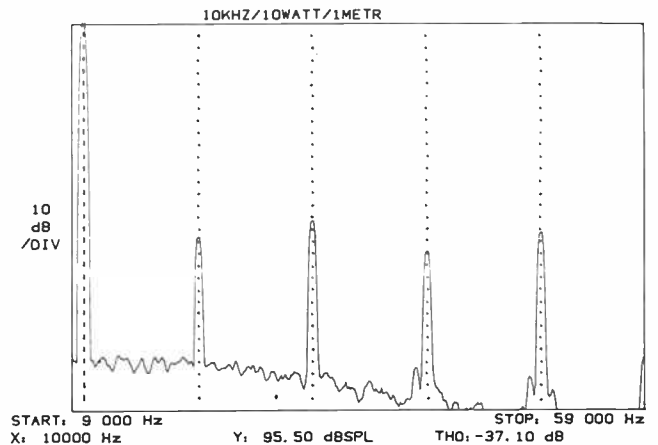


Figure 9. 10 kHz distortion performance at one metre, but with 10 W drive.

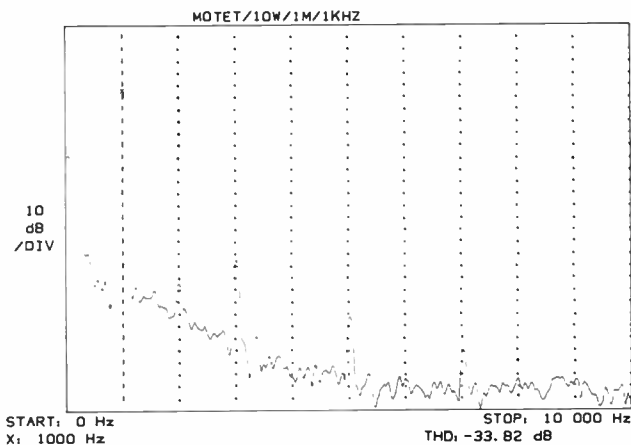


Figure 7. Distortion performance, again at 1 kHz and 1 m, but with 10 watts drive.

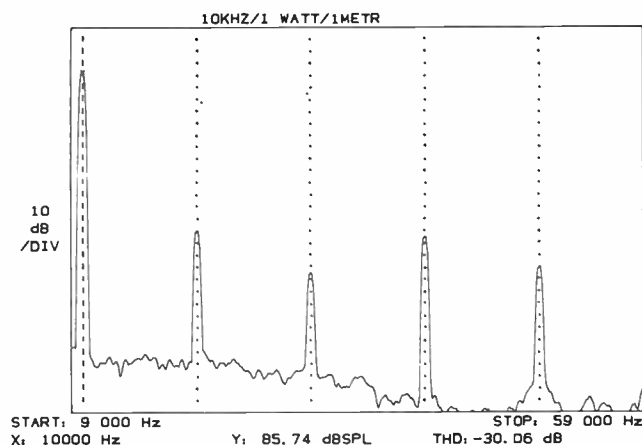


Figure 8. 10 kHz distortion performance, at one metre with 1 W drive.

### Power Handling

We found (the hard way) that the power handling capacity of the Motet is not very forgiving. Power handling capacity of the 8011A is stated to be 50 watts. One of the claims made by many manufacturers over recent years, Audiosound included, is that their equipment is suited to digital sound. (At the same time, other manufacturers are eagerly selling loudspeaker protection circuits.) My own firm opinion is that if you want to run a CD player in your system, and particularly if you want to listen to classical music or live recordings in which the dynamic range is large, then there is no substitute for power, power and more power.

On CD source material, live music recording being replayed at quite comfortable listening levels, we were astonished to see one Motet bass driver loudspeaker fail. On the second Motet, we have no real excuse. We caused the bass driver to fail with a 1 kHz input tone inadvertently set to about 100 watts. We don't really know the power at which the driver failed since it did so as the power was being increased to a final setting of 100 watts. Rated amplifier power was 100 watt and in neither case was amplifier clipping occurring. Whilst the manufacturer does indicate a power limit of 50 watt, the safety margin on the Motet is clearly not great and I would advise caution in its use. In fact, if my earlier guess at the bass driver make is right, I suspect the power handling capacity of the unit may be nearer 30 watts than fifty.

### Pulse Tests

The pulse tests given in Figures 10 and 11 highlight a number of anomalies in dynamic performance of the speakers. The most significant of these for the bass unit (Figure 10) are the pronounced bass lag at 80 Hz, a phase-related dip at 320 Hz and the serious dip in performance around 1 kHz. On pulse testing, the deficiency at the crossover can be seen to be quite extreme. Whilst it is not easily seen on the magnitude map display, the anomaly at 320 Hz comprises a very rapid dip in level followed by a crest, or in other words, a 'flutter'. No obvious reason exists for the 80 Hz lag other than probable overdamping of the bass driver due to the sealed enclosure, or perhaps ringing of the box itself. The tests were conducted free-field so there is no contribution from room effects and the lag is clearly a design-related problem. In view of the magnitude of the delay, I am surprised that it was not subjectively more obvious. However, as I have suggested, the deficiencies at high frequencies are more serious and therefore tend to dominate subjective performance assessment. ▶

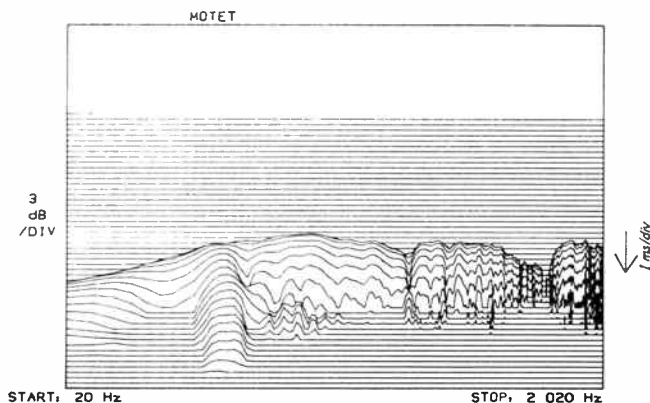


Figure 10. Motet 8011A, impulse source frequency/time response at the bottom end of the frequency range.

The pulse test shown on Figure 10 is for the loudspeaker as a whole, that is, with the tweeter and crossover unit in-circuit, and the roll-off of the bass driver below the crossover frequency can be seen to be quite extreme.

In Figure 11, the tweeter band performance, a similar lag may be seen from the tweeter just above the crossover frequency and this is almost certainly the result of a high Q crossover. Again, something which can be designed out. At 3 kHz the dip apparent in the swept sine wave tests is again seen to be even more significant, as is the poor performance above 7 kHz.

On pulse testing we can see much more clearly how large the 'windows' in performance of the loudspeaker really are. In relation to speech performance, the wideband gaps in information between 1 kHz and 3 kHz will, by all theory, result in clear loss of speech intelligibility. With pop music, the broadband nature of much of the source material will not be so affected by these deficiencies, although this is changing as popular music becomes progressively more complex. The advent of the compact disc will only increase this.

## In conclusion

As I have said at the outset, the Motet 8011A is a budget loudspeaker and its performance should be reviewed as such. It is always difficult for an intending purchaser to filter the claims made in supportive literature for all products, since even low budget systems seem to offer performance capacities which differ little from many more expensive alternatives. From a marketing viewpoint, my impression is that the Motet loudspeaker is suggested for a wide variety of users. The nomenclature on the loudspeaker refers to it as a monitor and the very name Motet, evokes a musical expectation. In these respects I feel the loudspeaker would be a disappointment to intending purchasers. However, as we have always recommended in our reviews, listening tests are the only way for you to judge whether the loudspeaker meets your own expectations. The units are low-priced and do seem reasonably well-suited to popular music. For the den, the kids' study or games room the units are well worth comparing with other competitive brands, however, don't expect to use them for long, loud parties in larger rooms.

As I've said, in the loudspeaker industry you do get what you pay for. The loudspeaker is one of the most critical components of any sound system and the use of the Motet in a system using other much more expensive components would simply not be warranted.

## SUMMARY OF RESULTS

### Frequency Response

Drivers alone 55 Hz to 9 kHz +/- 3 dB  
Loudspeaker Nominally 100 Hz to 6 kHz +/- 3 dB

### Sensitivity

86 dB/W @ 1 metre @ 1 kHz

### Impedance

3 to 8 ohm

### Power Handling Capacity

?

### Crossover frequency

1100 Hz

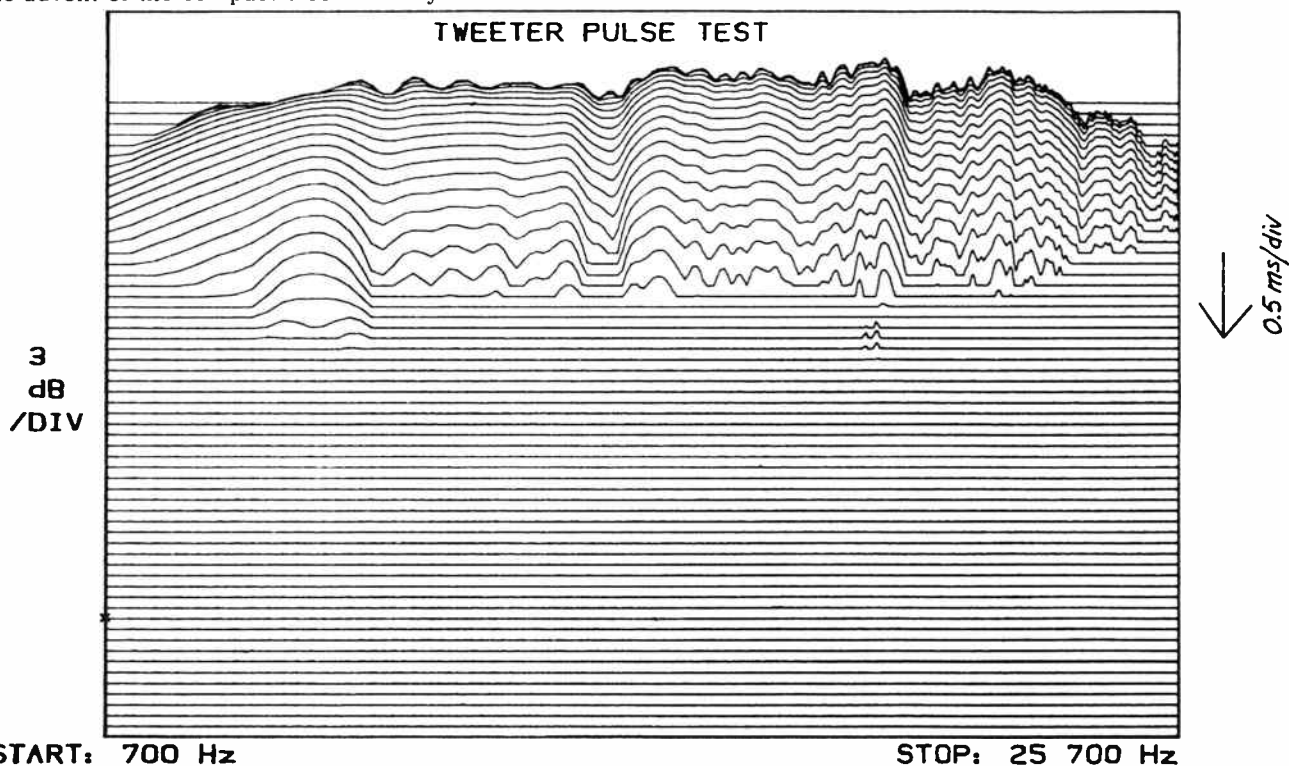
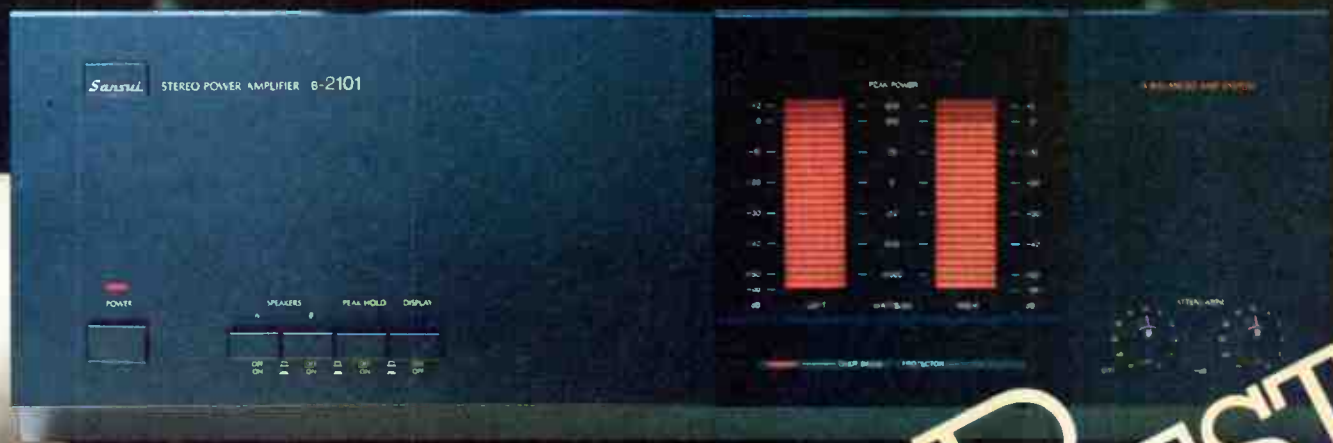


Figure 11. Motet 8011A, top end frequency/time response to an impulse source.





**TU-D99X** SLDD Digital Synthesizer Tuner  
**C-2101** Stereo Control Amplifier  
**B-2101** X-Balanced Power Amplifier



\*RMS power output: 200 watts  $\times$  2 (8 ohms),  
20Hz - 20kHz, less than 0.003% THD.  
Dynamic power output: 680 watts  $\times$  2  
(2 ohms).

**OWN THE BEST**  
The best is only as far away as your nearest Sansui dealer.



**SANSUI ELECTRIC CO., LTD.** 14-1 Izumi 2-chome, Suginami-ku, Tokyo 168, Japan  
**VANFI (AUST.) PTY. LTD.** 297 City Road, South Melbourne, Victoria 3205, Australia Tel: 690-6200  
283 Alfred Street, North Sydney, N.S.W. 2060, Australia Tel: 929-0293

# 25 LINES OF 80 CHARACTERS! FLAT PANEL DISPLAYS AVAILABLE NOW!!

This is the actual effective display size of LJ512U05



\*\*\* LJ512U05 SPECIFICATIONS \*\*\*

- Effective Display Area (mm)  
96 (L) × 192 (W)
- Number of Matrix Electrodes  
512 Column Electrodes \*  
256 Row Electrodes
- Number of Picture Elements  
131,072 (512 × 256)
- Picture Element Size (mm)  
0.225 (L) \* 0.275 (W)
- Picture Element Pitch (mm)  
0.375 (both lengthwise and  
widthwise)
- Display Color  
Orange-yellow  
(peak wavelength 5850Å)
- Brightness  
25fL (standard)
- Frame Frequency  
60Hz (standard)
- Input Signal Level  
LS TTL Level
- Outline Dimensions (mm)  
148.5 (H) × 228.5 (W) × 35 (D)
- Weight  
Approx. 650g

Sharp's full line of EL (Electro Luminescent) Displays are thin (34mm), lightweight (650 grams), low power (15 watts max) and the two latest editions can display 25 lines of 80 characters. These "State of The Art" Displays feature; line by line scrolling, blinking characters, full graphics and a

simple 4 line interface. EL's bright, crisp, easy to read characters will enhance the marketability of any product.

Design the leading edge of display technology into your products today using displays from Sharp, the world's largest manufacturer of EL Displays!

**LJ512U01** • Ideal for written characters • Effective display area 44.8mm × 179.2mm • Number of picture elements 512 × 128  
• Outline Dimensions (mm): 108.5(H) × 228.5(W) × 34(D)



**LJ320U01** • Ideal for fine graphics as well as written characters • Effective display area 90mm × 120mm • Number of picture elements 320 × 240  
• Outline Dimensions (mm): 148.5(H) × 178.5(W) × 34(D)



**LJ512U05** • Ideal for fine graphics as well as written characters • Effective display area 96mm × 192mm • Number of picture elements 512 × 256  
• Outline Dimensions (mm): 148.5(H) × 228.5(W) × 34(D)



**LJ640U01** • Ideal for written characters • Effective display area 60mm × 192mm • Number of picture elements 640 × 200  
• Outline Dimensions (mm): 108.5(H) × 228.5(W) × 34(D)



## EL DISPLAY

Distributed in Australia by:



64-66 Bay Road  
Sandringham  
Victoria 3191  
Australia  
PO Box 114

Telephone (03) 598 5622  
Telex AA34439 World Radio Hist

Suite 28  
47 Falcon Street  
Crow's Nest  
NSW 2065  
Australia

Telephone (02) 957 2464  
Telex AA20801



SPONSORS OF  
TASKFORCE  
1987

# Eagle ELECTRONICS

Pty. Ltd.  
271 2885

**EXPERT  
ADVICE!**

FOR THE ENTHUSIAST  
AND PROFESSIONAL!

## OPENING SPECIAL! \$35

10-PACK VERBATIM 5 1/4" DISKS IN PLASTIC CASE

8-INCH 3-WAY  
PIONEER  
SPEAKER KIT **\$29<sup>95</sup>**

MICRON  
25 Watt  
Soldering Iron **\$17<sup>50</sup>**

EA FUNCTION  
GENERATOR  
KIT **\$99<sup>50</sup>**

BRAKE LAMP  
FLASHER KIT **\$16<sup>50</sup>**

SQUEAKY CLEAN  
MAINS FILTER  
Stop interference  
on your  
monitor. **\$119**

HOUSE  
ALARM KIT **\$149**

ALSO STOCKING A WIDE RANGE OF  
PLUGS, SOCKETS, SEMI-CONDUCTORS,  
ACCESSORIES & KITS!

**54 UNLEY ROAD, UNLEY**

## A HANDHELD LCD 3 1/2-DIGIT DMM FOR LESS THAN \$50

The Parameters 8005 features:

- 3 1/2-digit liquid crystal display
- 5 functions
- 15 ranges
- side pushbutton operation
- 'pocket' size — 130 x 75 x 28 mm
- dc volts to 1 kV in four ranges
- ac volts to 750 V in two ranges
- resistance to 2M in four ranges
- diode test
- basic accuracy, 0.5% (dc V)
- fully overload protected
- safety 'finger guards' on probes
- fully shrouded safety probe plugs
- low battery indicator
- 12 months warranty!

**Special  
Offer Price:  
\$49.75**  
inc tax, post and packaging



How to order:

COMPLETE THE COUPON AND SEND IT, TOGETHER WITH YOUR CHEQUE,  
MONEY ORDER OR CREDIT CARD DETAILS, TO:

'Parameters Multimeter Offer'  
Australian Electronics Monthly  
PO Box 289, WAHROONGA 2076 NSW

Please allow up to four weeks for delivery.

COUPON

**PLEASE RUSH ME . . . Parameters 8005 dmm(s).**

I enclose payment by:

Money Order  Cheque\*  Credit Card

Bankcard  Visa  Mastercard

Credit Card No.: .....

Expiry date: .....

Cheque or Money Order No: .....

\*Please make cheques or Money Orders payable to  
'Australian Electronics Monthly'.

Name .....

Address .....

Postcode .....

Signature .....

(Unsigned orders cannot be accepted)

## ALL ELECTRONIC COMPONENTS

118-122 LONSDALE STREET,  
MELBOURNE, VIC. 3000, Australia  
Telephone (03) 662 3506

## JOIN THE GOLDRUSH!

ETI 1500 KITSET.  
Super unit featuring:

- Tune and discriminate
- 4 modes of operation
- VLF/TR design • Ground balance • Auto balance push buttons • Pre-wound search head • Very professional unit • Approximately 1/3 price of many similar commercial built up locators • Audio and meter indication. Lets you know when to rejoice

## COMPLETE KIT

Even inc Solder & Wire

**\$264.57**

plus \$9 88 P & Reg. P.

"AN ENJOYABLE PASTIME  
WITH THE CHANCE TO  
MAKE A FORTUNE"

# The new 8mm video tape technology

## Part 2

Malcolm Goldfinch

The 8mm tape format is the leading edge of a new consumer product group that promises integration of audio, video and 'digital' products for home use.

IN PART 1 we established the rules for the new V8 format and got the ball into play by following an image through the lens of a Sony CCD-V8 camcorder, then showing how it is processed by the new CCD imaging system, which includes, auto white balance, timing, synchronising by clock, matrix delay and encoding. The result was an output of four separate sets of signals; two video, one function and one audio. The mini TV with a 1" screen in B&W is the EVF (electronic viewfinder) and is fed a signal which is an image identical with the one to be recorded. (See Figure 6). This EVF also has LED signals activated by the processor to warn the user of what is happening in the camcorder; such as, white balance needed, low light, recording, battery low, etc.

Audio comes from a mic in the camera to the signal

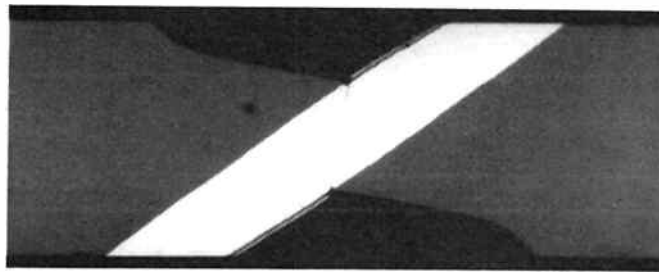


Photo 1. Microphotograph of the SSS head. You might be lucky to discern the gap.

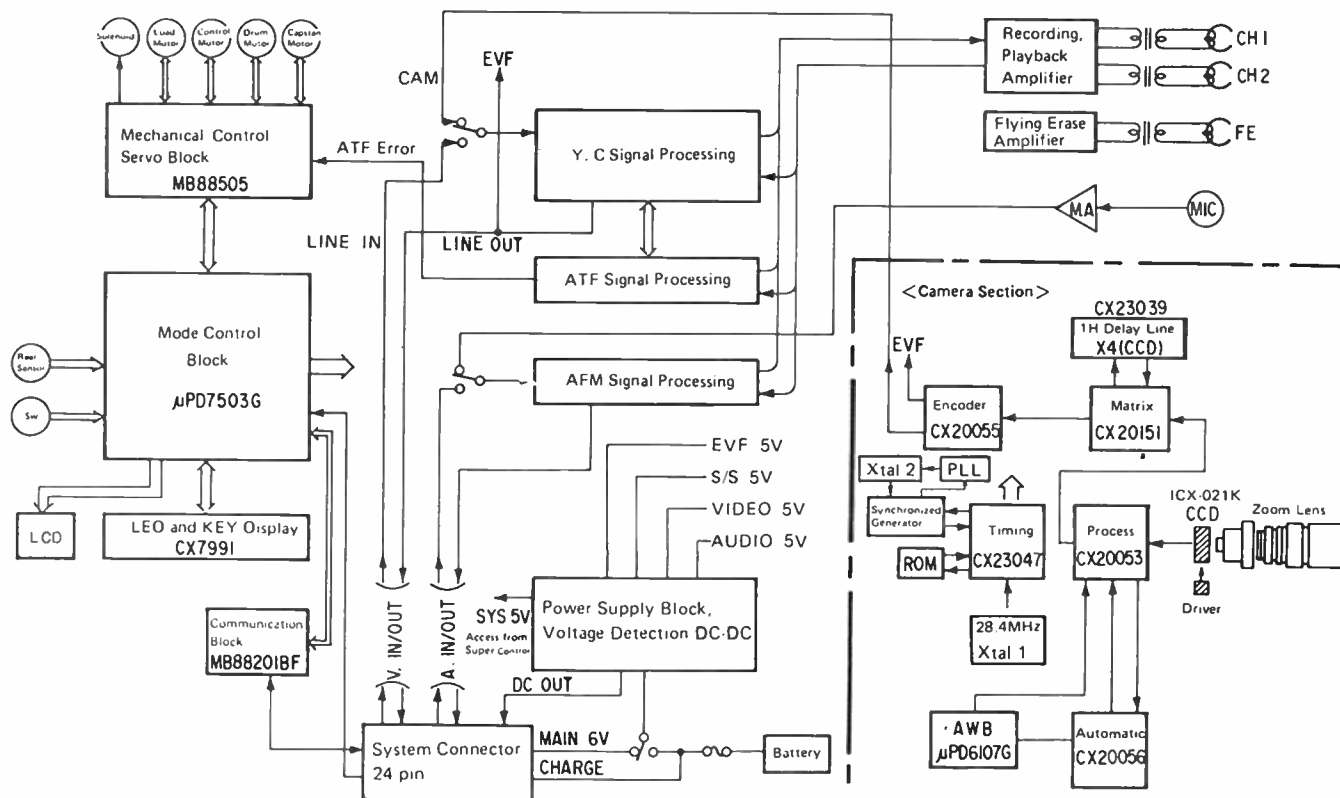
processing direct and is processed into a multiplex FM signal and fed to the recording playback amp with two record/replay heads (Ch1, Ch2).

### V8 specifications

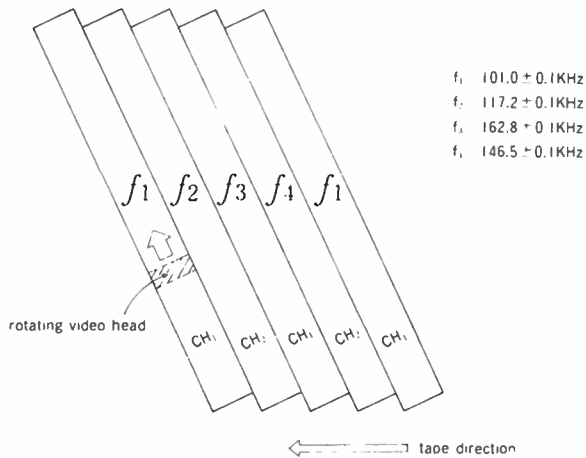
The V8 specs call for the recording and playback at considerable levels on the 8 mm tape of a band extending some 8 MHz wide. Figure 7 shows the direction, rotation, record/replay track of heads mounted on the V8 format 40 mm rotating drum.

Quantifying the actual head writing speed over the tape is a complex calculation as there is a vector between the heads rotating at 1500 rpm diagonally across the tape and the tape moving in the same direction at 20.0151 mm/sec in Standard Play (normal) and 10.058 mm/sec in Long Play. (Compare this to a cassette with tape speed of 48 mm/sec). The result is a series of diagonal tracks with a pitch of 30.4 μm in standard play, and 17.2 μm in long play. Some manufacturers seem a bit coy about quoting head widths and the actual details of relative speed of the heads over the tape, which is conceded the most critical factor in wideband tape recording.

The formats are rigid and the table here compares the basics of the principal VCR formats; showing the Philips com-



6. Overall block diagram of the Sony CCD-V8 camcorder.



**Figure 7. The 8 mm video recording track format. There are two record/replay heads (Ch1 and Ch2) and four pilot tones for tracking (f1 to f4), laid down with the video signal, not along the edge of the tape as with conventional VCRs. This system, proposed by Philips, is called 'ATF' — automatic track finding. The four pilot tones are laid down sequentially — f1 and f3 by the Ch1 head, f2 and f4 by the Ch2 head. (See also Figures 10 and 11).**

compact audio compact cassette as a benchmark.

Exhaustive specifications given in the "confidential" Sony V8 Format handbook, specify heads travelling over moving tape at a "head-to-tape speed" of 314 cm/sec in both standard play (SP) and long play (LP). For PAL video, the drum speed must be 25 rps and, multiplied by the circumference of the 40 mm head drum, the scan of the stationary tape is 314.2 cm/sec for a stationary picture.

On standard play (SP), the tape is moving in the direction of the head scan and this speed must be reduced by the vector of the diagonal head scan in relation to the tape speed; 20.05 cm/sec in SP, or LP 10.06 cm/sec. Being such a small portion of the total writing speed it is of little consequence. It is obvious that the writing speed of V8 is very much less than the VHS or Beta formats by 170 cms/sec, or 35% on VHS. More than five years ago, any of these specifications would be a laboratory absurdity, but to-day they are a consumer product for grandmothers to use on their children!

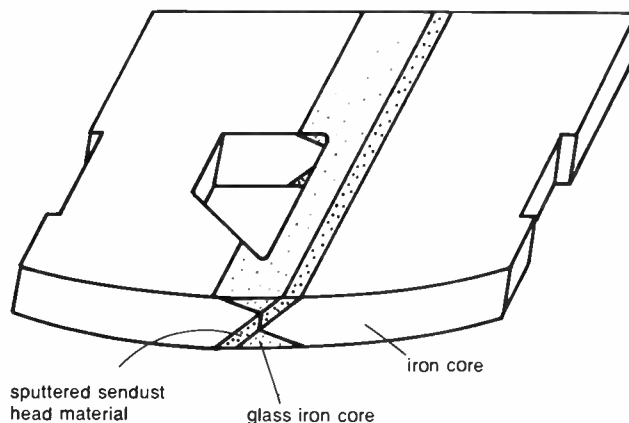
But how does V8, at such a low writing speed and narrow track width, achieve such a high quality video picture and soundtrack from just one head?

## Tape coating and head parameters

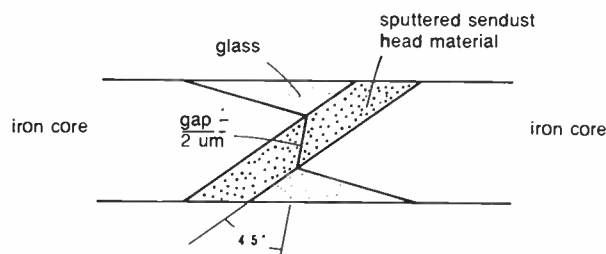
These are the vital new factors that allow such wideband signals in such a small package. Figure 1 in Part 1 shows tape

coating thicknesses for both metal powder and metal evaporated ( $0.15\mu$ ) coatings compared with Beta tape ( $5\mu$ ) as a benchmark. Such fine tape material is useless without an improvement in head technology to match.

The Sony CCD-V8 record/playback heads are a vital part of the products success. In Figures 8 and 9 you see Sony's "Slanted Sendust Sputtered" (SSS) head. The gap width is  $2\mu\text{m}$  with an approx.  $30\mu\text{m}$  depth. The output developed is  $150\mu\text{Vp-p}$  with metal particle tape at a track width of  $25\mu\text{m}$ . Photo 1 is a microphotograph of the  $2\mu\text{m}$ -wide head and the faint diagonal line which I call the 'Claytons' head gap . . . when you are apparently not having a gap. The only detail I can get is" . . . a new technique called SSS . . . combines two different types of sendust glass into a head with an extremely precise narrow gap giving a narrow uniform recording field . . . track width  $21\mu$  . . ." The head material is made by sputtering, or electro depositing in a vacuum, two different types of glass, or sendust (sideways?); all the details are very secret, but it works well to achieve extraordinary video quality.



**Figure 8. The 'Slanted Sendust Sputtered' recording head.**



**Figure 9. Close-up of the head construction showing how the narrow  $2\mu\text{m}$  gap width is achieved.**

**TABLE 2**

**TAPE, SPEED & SCAN SPEC. BETA, VHS, COMPACT CASSETTE, FORMATS.**

Format	Tape Speed	Head Track Width	Helical Scan Speed	Max. Run Time
BETAMIX	18.7cms/sec	32.8 $\mu\text{m}$	585.36 cms/sec	3.2 hrs
VHS STANDARD PLAY	23.3cms/sec	49.0 $\mu\text{m}$	484 cms/sec	4.0 hrs
VHS LONG PLAY	11.7cms/sec	24.5 $\mu\text{m}$	484 cms/sec	8.0 hrs
V8 STANDARD PLAY	20.05cm/sec	20.0 $\mu\text{m}$	314.2 cms/sec	1.5 hrs
V8 LONG PLAY	10.06cm/sec	20.0 $\mu\text{m}$	314.2 cms/sec	3.0 hrs
COMPACT CASSETTE	48.0cms/sec	600.0 $\mu\text{m}$ *	Not Scanned. Single side, one hour	

\* The head track width of the compact cassette was laid down some 20 years ago.

## Long play squashup

There is a grey area about this SP-LP speed change, which to my eye seems to have little effect on picture quality and none on sound. I buy the explanation that the speed of the heads over the tape is a drum function and the difference in linear speed of the tape is not significant.

In fact, the actual speed at LP should be greater, because the tape moves with the scan and this speed is halved. (See Table 2). But what about the 'squashup'?

The same heads are used for both SP and LP; slow the tape to half speed and you write over half the previous track? The answer I have got, reluctantly, from a number of manufacturers of video hi-fi VCRs is: "Yes, there is some overlap in LP but the 10 degree azimuth, which is plus on one track, and minus on the next, is enough to allow this overlap record/playback, without erase, and without the heads reading too much random noise on the out-of-azimuth overlap. In other words, this is a technical grey area which would seem to have many problems but the suck-it-and-see tests have shown the LP overlap is acceptable; considering it halves tape cost and doubles continuous record playback time.

This theory is borne out by the figures in Sony's V8 manual which says, "video track pitch( $\mu\text{m}$ ) 34.4/17.2." Presuming they refer to SP and LP respectively, the head leaves a  $21\mu\text{m}$  track, so in SP there should be a free space of  $34.4 - 21 = 13\mu\text{m}$ , being  $6.5\mu\text{m}$  free on either side of the tracks. In LP, the pitch is  $17.2 - 21 = -3.8$ , being an overlap of  $1.85\mu\text{m}$  over adjacent tracks. I cannot get confirmation of this hypothesis but it seems logical from the next V8 feature.

## Tracking, heads and azimuth

These inter-related factors make the remarkable performance of the CCD-V8 possible; especially in LP. With a head track-width of only  $21\mu\text{m}$ , the heads must pass along the recorded tracks with extreme accuracy, not only when the unit is new but when there is wear and some loss of mechanical precision.

Since Beta and VHS formats were frozen, technology has moved ahead and Sony CCD-V8 uses a new concept. Previous auto track-finding relied on control signals recorded along the edge of the tape and read at a remote spot from where the action was going on at the head drum. In fact, the V8 auto track-finding (ATF), a system developed by Philips, does away with tracking control signals. It is all accomplished in the flying scan by sampling the adjacent tracks to the one being scanned; a servo centers the head by equalling the side-band signals. It is claimed to eliminate noise bands and rolling.

In Figure 7 is shown the four pilot tracks recorded side by side —  $f_1$  and  $f_3$  by head 1,  $f_2$  and  $f_4$  by head 2 — in alternate scans. This allows the heads to sample pilot tones on the adjacent tracks e.g. playing Ch2, frequencies on adjacent channels 1 and 3 are also detected and the servo driven so that tape speed and drum rotation speed are kept close to a constant. Figures 10 and 11 detail the pilot tone frequency relationships and how the head overlap picks up the tracking pilot tones during incorrect and correct tracking.

Azimuth now raises its ugly head, as ever, but the frequencies of the pilot signals are in the 'long wavelength' and suffer little loss with azimuth variation, thus allowing adequate detection from adjacent tracks. To prevent the pilot signals breaking up the picture, they kept 14 dB below the chrominance level. The plusses claimed for the ATF system in the V8 are — nor tracking adjustment, tape variation does not affect tracking, and a simple tape path.

## The recording spectrum

This is where V8 takes a leap ahead of other formats.

Figure 12 shows the frequency distribution areas within

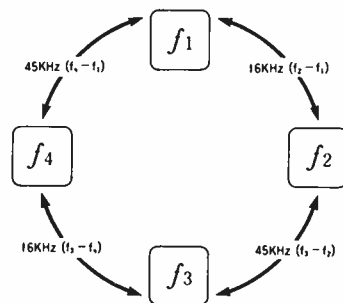


Figure 10. The relationship between the four tracking pilot tones.

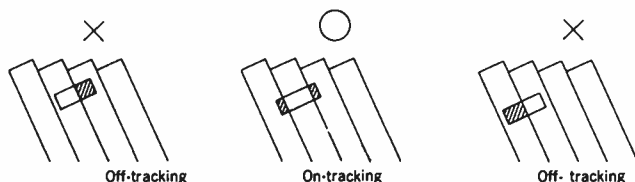


Figure 11. (See also Figure 7). During playback, the rotating video heads detect the pilot signals on the adjacent track(s) and compares their levels. The drum speed and rotation are controlled so that the level difference between the main pilot signal and the adjacent track pilot signals will be equal.

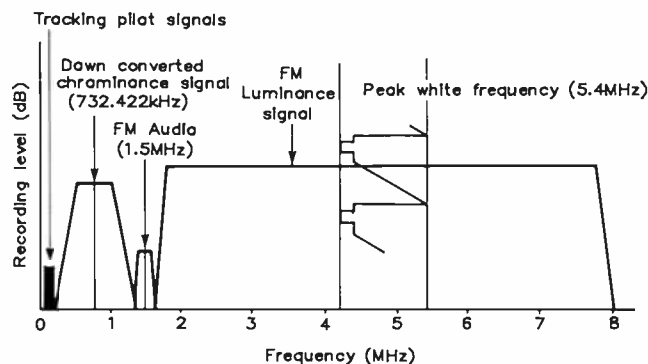


Figure 12. The Video8 recording signal frequency spectrum.

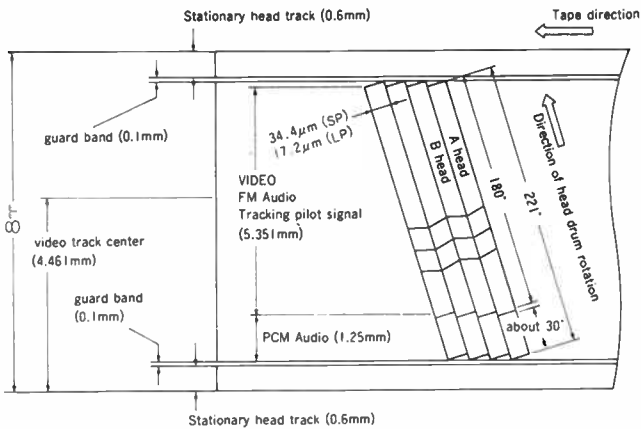
the rotary scan. The major departure is the inclusion of pilot and audio FM multiplex in the scan spectrum, together with a scanned erase.

With the record tracks having no spacing and mixing at the joins, one of azimuth's dirty tricks is used to ensure separation; each head is offset from vertical by 10 degrees in opposite directions, thus rejecting the adjacent track's signal except for the low frequency ATF pilot signals. Figure 13 shows the tape format details. In Figure 14, the PCM addition can be seen. Previous formats, including the first 8 mm format, had a 180 degree wrap around the drum. The V8 format has increased this by 41 degrees to 221 degrees. The PCM signals described later are accommodated in the extra wrap.

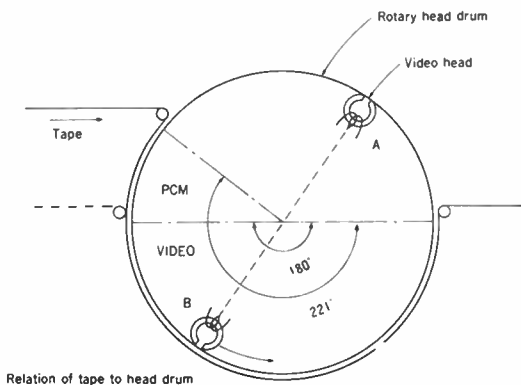
## The flying erase

In video, housekeeping is a vital function and the inclusion of the total recording gamut on the flying heads allows a 'flying erase' to clean up with equal precision. This is a valuable innovation employing an amplifier and head as a separate unit, switched on and off by the signal processor (Figure 6).

It is an integral part of the big leap forward in the CCD-V8. Whereas the VHS/Beta et al, formats used a block erase head for the whole tape width; remote from the scan drum, the flying erase head is on the drum and close to the record head.



**Figure 13.** The complete 8 mm video tape format, showing the video, FM multiplex audio and PCM audio track relationships and how they are laid on the tape.



**Figure 14.** The tape-drum wrap, showing the relationship of the two video heads and the direction of movement of the tape and drum. Note that the tape wraps round the drum for 221 degrees.

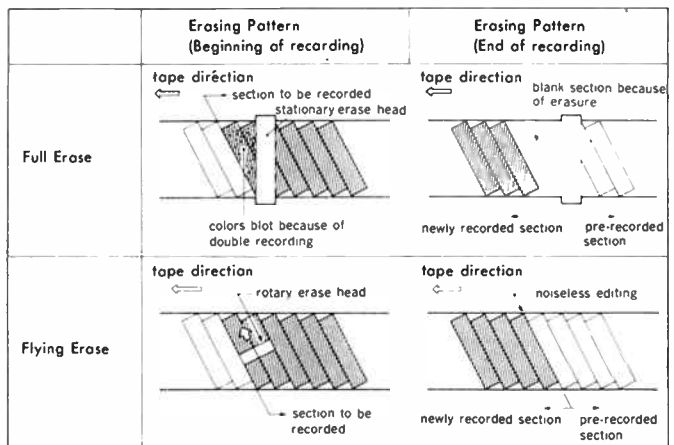
Consider the previous home video edits. Before each new sequence, tape had to be first rewound to a point prior to the block erase, losing up to three seconds, before new video could be laid down. Although it is possible to insert-edit video on a previously recorded tape, it is not 100% being done without proper erase. The sound and control tracks on the edge must be left intact (later audio dub, not lip-sync, is possible) to avoid a period of about seven seconds of glitch lines; an age in video. This occurs whenever a full insert is made in the middle of a recording; the control track is erased.

The most noticeable advance in the V8 flying scan insert-edit is the elimination of all glitches; 'rainbow' effects and 'stains' often seen at the start of a take are eliminated.

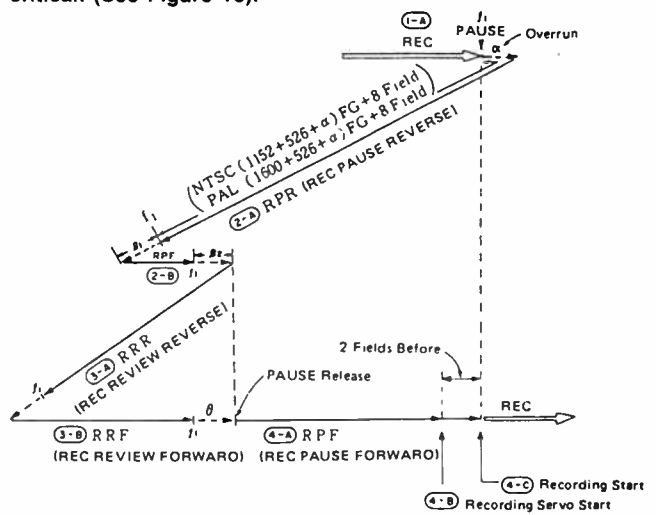
## Pro quality edits

In the CCD-V8, edit in and out points are held in memory for clean cut insert editing. Only professional VCRs and consoles in the \$10 000 range were previously able to give perfect insert edits. The Sony CCD-V8 provides faultless editing at consumer affordable cost. Figures 7 and 10 show the CCD-V8 four-field scan sequences essential for the PAL video standard, and the four pilot signals for auto track-finding:  $f_1 = 101.024$ ,  $f_2 = 117.188$ ,  $f_3 = 162.760$ ,  $f_4 = 146.484$  kHz, making a full four-field insert possible.

Three dedicated microprocessors select modes, safely sequence the mechanical section from commands by key, remote control or tuner/timer. Figure 16 shows the intricate timing required to perfectly frame an edit, which is achieved by the chip control of the tape and capstan. Backing up is only 1.2 seconds, and forward is but 0.4 seconds, a nett loss



**Figure 15.** The Video8 employs 'flying erase', as used in professional VCRs, to achieve noiseless editing. Conventional VCRs employ a stationary erase head which leaves a blank at start and finish of the edit, causing colour 'stains'. The flying erase technique employs a rotary erase head to eliminate this problem, but timing is critical. (See Figure 16).



**Figure 16.** Sequence showing how smooth editing is achieved.

of only 0.8 seconds to get rid of any daggy ends when "pause" is activated.

When "record" is resumed the tape is locked to the correct field sequence and commences at the exact point marked. This also allows a most valuable feature in precise editing; a view on TV of the last three seconds recorded previously without loss of the edit point.

Working in an area of such fine tolerances is desirable, but not mandatory, to use the accessory automatic editing controller, which allows an 8-event memory communicated to the record system of the Sony CCD-V8 via a serial interface.

## Dynamic track following

Everyone familiar with home video accepts a bar or two of horizontal hash across the screen during search backward or forward, slow motion or still, as the azimuth inclination is not fixed. Some expensive VCRs avoid the problem with double azimuth heads. A method of overcoming the problem in the V8 format was suggested by Philips in conjunction with the ATF described above. Known as the DTF system it makes use of 'bimorphic torque' that bends two ceramic plates when a current is applied. Figure 17 shows how the direction of torque is reversed when the polarity is changed. With polarity and current correctly applied through a processor cou-

to p110. ▶

## Attention modem constructors

The AEM4600 dual-speed modem has been a resounding success, with suppliers reporting keen enthusiasts "storming the battlements" for boards, bits and kits. For enthusiasts chasing the odd 'elusive' components, or those looking for kit suppliers, here's a rundown of who's got what.



In last month's Project Buyers Guide on this page, we listed who had indicated 'intentions' of stocking kits — namely, Jaycar, Geoff Wood Electronics and Dick Smith Electronics. Well, both Geoff Wood Electronics and Jaycar indicate they should have complete stocks for kits this month. However, Dick Smith Electronics has since indicated they will not be stocking the AEM4600 modem kit, unfortunately.

If you're assembling the project yourself from parts on hand and buying-in the parts you don't have, then you're most likely after such things as the '7910 modem chip, the 2 uF isolating capacitor, the crystal and pc board.

The distributors of both makes of the '7910 were listed in the data sheet published last month — R&D Electronics for

the AM7910, and Promark for the EF7910. If you're looking for retailers of this device — try Geoff Wood Electronics in Sydney, Active Electronics, Magraths and Rod Irving Electronics in Melbourne and Protronics in Adelaide.

The 2 uF/440 V capacitor is distributed by Captron in Melbourne, but try Geoff Wood Electronics in Sydney or Protronics for them in Adelaide. The 2.4576 MHz crystal is a relatively common item. Try Geoff Wood in Sydney, Radio Parts and Rod Irving Electronics in Melbourne.

Printed circuit boards are stocked by ourselves (see the coupon in our advert elsewhere in this issue), Protronics in Adelaide, possibly All Electronic Components in Melbourne, and Geoff Wood Electronics in Sydney.

### Dick Smith Electronics maps out new moves

Hardly a week goes by when they aren't doing something new, it seems. The ever-present Dick Smith Electronics has relocated the Brisbane city store from Adelaide St to 157 Elizabeth St, which explains why you thought it was missing.

For the good citizens of Underwood QLD, not to mention all the local electronics enthusiasts, the indefatigable DSE crew has opened a new store in the area. Located on the corner of Kingston Rd and the Pacific Highway, you'll find all the familiar stock lines there and an enthusiastic enclave of electronics entrepreneurs eager to 'elp you.

### PROJECT BUYERS GUIDE

The AEM6103 'Digital Era' Three-way Loudspeakers are the top of the range in our series of passive speaker projects. This project features performance rivalling the most expensive systems available. The Danish-made Vifa drivers are distributed by Scan Audio, PO Box 242, Hawthorn 3122 Vic. (03) 429 2199. They'll be able to advise your nearest stockist of drivers, crossovers and kits. Jaycar in Sydney has indicated they'll be stocking kits.

The AEM4503 'Port-A-Bee' is an intriguing and useful project with wide application. The Hitachi LM018L liquid crystal display used in the prototype came from Energy Control, PO Box 6502, Goodna 4300 Qld. (07) 288 2455. Jaycar are agents for the Lascar LCD displays from the UK. The DMX402 is suited to this project, and you might enquire as to its availability from your nearest Jaycar store.

This month's Star Project, a UHF CB 13 element Yagi antenna, is from Dick Smith Electronics who will be stocking complete kits at \$39.95. Check your local Dick Smith store.

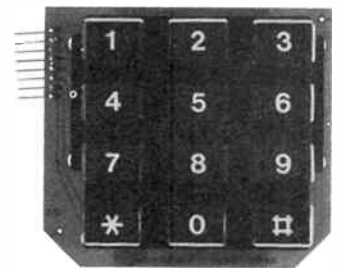
If at any time you're seeking printed circuit boards for any of our projects, you'll find them (generally) stocked by All Electronic Components in Melbourne, Geoff Wood Electronics in Sydney and Protronics in Adelaide. In the event you can't get the board you want, we keep a limited supply at the magazine. Call us on (02) 487 2700 for price and availability.

### 12-key keypads

If you're after a numeric keypad for that special project of yours — like a security system, add-on numeric entry pad for a microcomputer, etc — then check out one of the latest bargains from Altronics.

They have what is described as a 'commercial grade' 12-key keypad with the numerals 0 to 9 plus # and \* keys. They are arranged in a 4 x 4 array with connections via an 8-way wiring harness.

These keypads are of quite sturdy construction and, apparently, were supplied as standard on STC-made Telecom 'phones. Priced at just \$3.95 in quanti-



ties from one to nine, and significantly discounted in higher quantities, they can be obtained from Altronics, PO Box 8280, Stirling St, Perth 6000 WA. (008) 99 9007. Quote cat. no. A 0495 and tel 'em you saw it in AEM!

### Fuel flow sensors back in stock

Jaycar advises that they are once again stocking fuel flow sensors for the popular Voyager Car Computer, which has been out of stock for the past year.

These rugged, reliable sensors have been sought after as being the best of their type on the market. However, Voyager Car Computers are now out of production in the UK and Jaycar advises they do not expect to get any more of these fuel flow sensors.

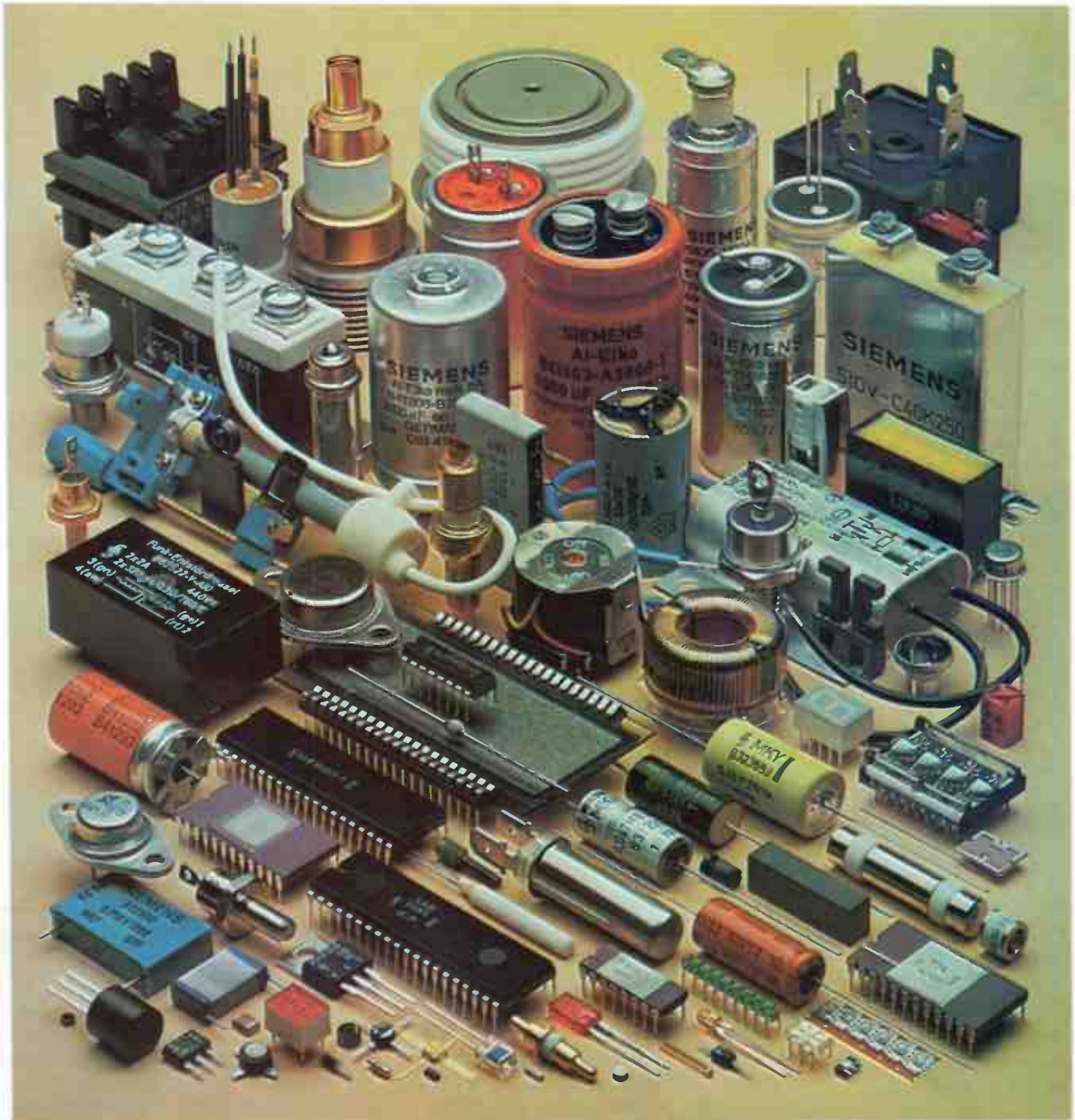
As you'd expect with a quality item, they're not cheap at \$45.00. Quote Jaycar cat. no. XC-2036. Jaycar stores are at four locations in Sydney, plus Buranda in Brisbane. Four stores are open Thursday nights until 8.30 pm — York St. Hurstville and Carlingford in Sydney, and the Brisbane store.

Readers note! — Jaycar has a new dealer, servicing the fair citizens of Adelaide and surrounds. You'll find the 'full line' of Jaycar products at Eagle Electronics, 54 Unley Rd, Unley, S.A., 'phone 271 2855.



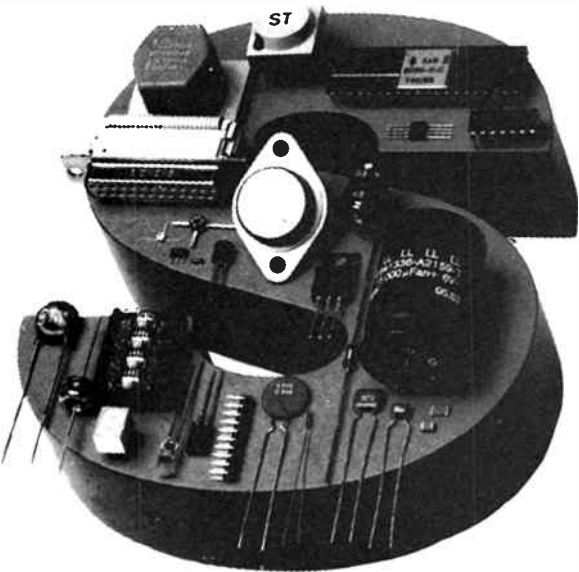
# SPECIALISED ICs APPLICATIONS COOKBOOK

Here's an anthology of useful circuits and interesting applications for a range of specialised ICs available through local dealers and distributors. The device and circuits have been chosen to illustrate practical solutions to circuit requirements in a wide variety of applications ranging across audio, power supplies, radio, displays and lighting control. An index of distributors and dealers stocking the device illustrated in this cookbook is given at the end.



# SIEMENS

## Electronic components range



### SMALL SEMIS:

#### Small-signal semis

- Switching and tuner diodes
- AF, RF, Darlington and Switching Transistors
- Subminiature packages including Surface mounted devices

#### Microwave components

- RF transistors
- GaAs FETs
- GaAs FET amplifiers
- Schottky and PIN diodes

#### Displays

- Intelligent Displays™
- Programmable Displays™
- Alphanumeric
- Bar graphs
- Numeric

#### Optocouplers

- Single and multi-channel
- Fast hi-rel, hi-speed and high voltage
- Low CTR degradation

#### Visible LEDs

- 3 and 5 mm standard
- Arrays
- Miniature and Subminiature
- Geometric shapes
- Two-colour

#### Infrared

- Emitters
- Photodiodes
- Phototransistors

#### Sensors

- Temperature
- Galvanometric
- Pressure

### POWER SEMIS

#### Large power semis

- Thyristors or diode modules
- Flatpack SCRs or rectifiers
- Stud mount SCRs or rectifiers

#### Small power

- Schottky and fast recovery rectifiers
- TO-220 Triacs/SCRs

#### Power MOSFETs

- SIPMOS
- SITAC
- SMARTFET

### ICs

#### Microprocessors and Peripherals

- SAB8086 & SAB80286 16-BIT family
- Floppy disk controllers
- SAB8256 MUART

#### Microcontrollers

- SAB8031/8051 & SAB80515/80535

#### Memory devices

- 64K dynamic RAM

#### Integrated circuits

- Telecommunication
- TV and radio
- Analog
- Industrial

### ELECTRO-MECHANICAL

#### Connectors

- 75 ohm coaxial
- DIN 41612

#### Cable

- 75 ohm Coaxial
- Ribbon

### RELAYS

#### Relays

- Socket-mounted
- PCB-mounted
- Mounting hardware
- Solid state

### TUBES & PROTECTION

#### Tubes

- RF heating
- Travelling wave tubes
- Lasers
- Special purpose tubes

#### Surge protection

- SVPR gas surge
- Voltage protectors
- Thermistors
- SIOVR varistors

### SYSTEMS

#### Floppy disk drives

- 3½" & 5¼" single & double sided slimline

#### Printers

- Silent thermal

### PASSIVES

#### Electrolytic capacitors

- Standard axial
- Standard radial
- Low-leakage radial
- High CV radial
- Low ESR
- Extended temperature

#### Polyester capacitors

- Axial wound
- Radial wound

#### Stacked film

- Non-encapsulated
- Epoxy-coated
- Box versions

#### Polypropylene/Polystyrene

- Axial
- Radial
- Encapsulated versions
- Flame-proof

#### Power capacitors

- Commutation
- Filtering
- Coupling
- Resonant
- Surge discharge

#### Ceramic capacitors

- E50000 dielectric
- Multilayer-Z5U, X7R
- COG

#### Filters

- SAW (surface acoustic wave)
- Filters & resonators
- RFI
- Chokes

#### Ferrites and Accessories

- For S.M. power supplies
- For Inductors
- For Transformers

# Touch Dimmer

Electronic Dimmer  
Electronic Light Switch

S 576 A, B, C  
S 576 D

MOS IC

The IC S 576, constructed in PMOS depletion technology, permits the design of a digital electronic dimmer or light switch. Turning on and off as well as the setting of the required brightness are carried out via a single sensor or via an equivalent extension input, respectively.

## Features

- Sensor operation – no mechanically moveable switching elements
- Operation is also possible from several extensions by means of sensors or push-buttons
- Can be interchanged with electromechanic wall switches in conventional light installations
- Easy connection to a wireless remote control
- Brightness control with a physiologically approximated linear characteristic
- Very high interference immunity
- The set brightness value remains stored during short line interruptions of < 1 s
- Low power dissipation
- Very few peripheral components
- Clock input provides for automatic dimming (slumber switch)

Maximum ratings (without external protective circuitry)		Lower limit B	Upper limit A	
Supply voltage	$V_{DD}$	-20	0.3	V
Input voltage	$V_I$	-20	0.3	V
Ambient temperature during operation	$T_{amb}$	0	80	°C
Junction temperature	$T_J$		125	°C
Storage temperature	$T_{stg}$	-55	125	°C
Thermal resistance (system-air)	$R_{th,SA}$		135	K/W

Characteristics	Test conditions	Lower limit B	typ	Upper limit A	
Supply voltage	$V_{DD}$	-18	-15	-13	V
Supply current	$I_{DD}$		1.0	1.4	mA
Supply current with missing sync signal	$I_{DD}$			0.85	mA
Input reverse current	$I_I$		< 0.1	3	µA
Input capacitance	$C_I$			5	pF

Sensor input	Test conditions	Lower limit B	typ	Upper limit A	
H input voltage	$V_{IH}$	$V_{as}-2$			V
L input voltage	$V_{IL}$			$V_{ss}-8$	V
Input current	$I_{IH}$			35	µA
HL transition time (trigger transition)	$t_{rHL}$		line sine wave		
LH transition time	$t_{rLH}$				
Frequency with active signal	$f$		50/80		Hz

Extension input	Test conditions	Lower limit B	typ	Upper limit A	
H input voltage	$V_{IH}$	$V_{as}-2$			V
L input voltage	$V_{IL}$			$V_{ss}-8$	V
Input current	$I_{IH}$			35	µA

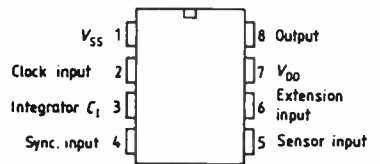
Sync input (pin 4)	Test conditions	Lower limit B	typ	Upper limit A	
H input voltage	$V_{IH}$	$1/2 V_{DD}+2$			V
L input voltage	$V_{IL}$			$1/2 V_{DD}-2$	V
Input current	$I_{IH}$			240	µA
HL transition time (trigger transition)	$t_{rHL}$		line sine wave		
LH transition time	$t_{rLH}$				
Frequency	$f$		50/80		Hz

Clock input (pin 2)	Test conditions	Lower limit B	typ	Upper limit A	
H input voltage	$V_{IH}$	$V_{ss}-2$			V
L input voltage	$V_{IL}$	$V_{DD}$		$V_{ss}+0.3$	V
HL transition (trigger transition)	$t_{rHL}$			100	µs
LH transition	$t_{rLH}$			100	µs
Clock frequency	$f_{CLK}$	0		500	Hz
Without clock	$V_{IO}$	$V_{ss}$		$V_{ss}+0.3$	V

Integrator (pin 3)	Test conditions	Lower limit B	typ	Upper limit A	
External components	$C_I$	compare with fig.1	47		nF

Output	Test conditions	Lower limit B	typ	Upper limit A	
L output current	$I_O$	$V_{DD}=-15V$ $V_{OL}=-3V$	25		mA
L pulse width	$t_{OL}$	50 Hz line	40		µs
H output voltage	$V_{OH}$	compare with text		$V_{ss}+0.5$	V
HL transition time	$t_{HL}$			20	µs
LH transition time	$t_{LH}$			20	µs

## Pin configuration top view



## Operation of the control inputs

Input potential during both half waves of the line phase:

Function	Line half wave	Sensor input	Extension input
operated	positive	L	H
	negative	0	H
not operated	positive	H	L or 0
	negative	0	0 or L

H:  $V_{IH}$   
L:  $V_{IL}$   
0: any

## Control behavior

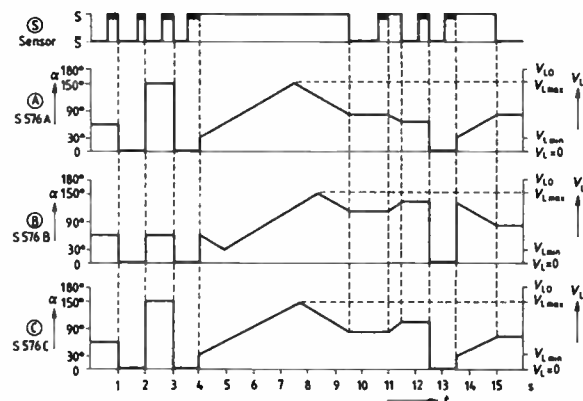
The three versions S 576 A, B, C, differ in their control behavior.

**S 576 A** With turning on, the maximum brightness is always set; with dimming, control is started from the minimum brightness. With repeated dimming, control is carried out in the same direction (e.g. "brighter").

**S 576 B** With turning off, the selected brightness is stored and again set when the switch is turned on. Dimming starts at that stored value and the control direction is reversed with repeated dimming.

**S 576 C** With turning on, the maximum brightness is always set; with dimming, control is started from the minimum brightness. The control direction is reversed with repeated dimming.

## Control behavior of the electronic dimmers S 576 A, B, C (schematic)



α Conduction angle S Control signal S Sensor touched A S 576 A  
 $V_L$  Lamp voltage (α < 0.4s; α > 0.4s) B S 576 B  
S Sensor not touched C S 576 C

Figure 1

## S 576 A, B, C S 576 D

Light switch S 576 D (see figure 2)

Upon touching the sensor area (> 50 ms) the lamp is turned on or off alternatively with maximum brightness. The switching process is activated at the start of touching.

Dimming or turning off the light via the clock input is also possible, as in the case with the dimmer.

Control behavior of the electronic light switch S 576 D (schematic)

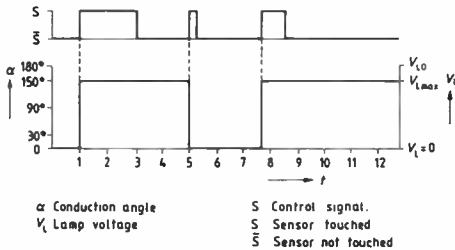


Figure 2

### Application circuit S 576

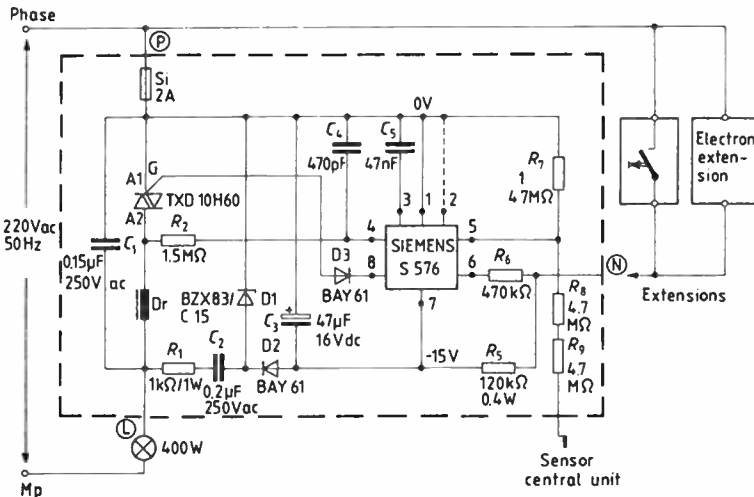


Figure 3

External circuitry (see figure 3)

The suggested circuit design of S 576 performs the following functions:

- current supply for the circuit ( $R_1$ ,  $C_2$ ,  $D_1$ ,  $D_2$ ,  $C_3$ )
- filtered signal for synchronization of the internal time base (PLL circuit) with line frequency ( $R_2$ ,  $C_4$ )
- protection of the user ( $R_8$ ,  $R_9$ )
- sensitivity setting of the sensor ( $R_7$ )
- current limitation in the case of incorrect polarization of the extension ( $R_5$ ,  $R_6$ ). Both resistors can be omitted if no extension is connected. In this case, pin 6 must be interconnected with  $V_{DD}$  (pin 7).
- D3: reduction of positive voltages which may arise during the triggered state at the gate of some triacs, to values below  $V_{SS} + 0.5$  V (refer to characteristic data). If suitable triacs are used, diode D3 can be omitted. (This feature of the triac depends on the anode current and on the internal resistance between G and A1, and can be measured and specified by the manufacturer).

#### Extensions

All switching and control functions can also be performed from extensions which are connected to an extension input reserved for this purpose. The central unit and the extensions are equivalent. Electronic sensor switches or mechanical pushbutton switches can be connected to the extensions. During operation, H potential must be applied to the extension input for both line half waves.

An electronic circuit suitable for this purpose, is shown in the application example (figure 4). The circuit operates as return delay and takes over the triggering of the switching transistors during the negative line half wave.

- Response time approx. 2 ms
- Return delay time approx. 30 ms
- Protection against incorrect polarization ( $R_1$ ,  $D_1$ ,  $S_1$ )

### Application circuit: electronic extension

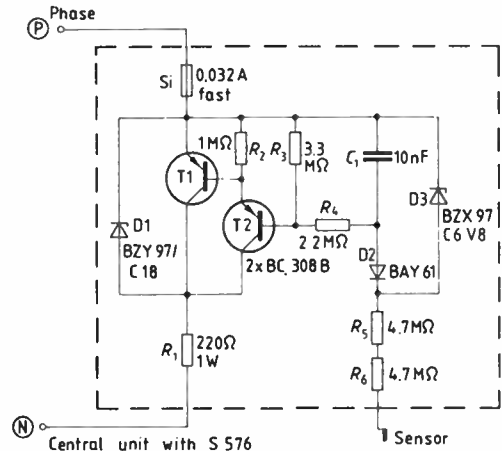


Figure 4

# AM/FM Receiver Chips

## AM Receiver IC with Demodulator

## TDA 4001

### Bipolar circuit

The TDA 4001 has been designed to convert, amplify, and demodulate AM signals. In addition, the component provides a search tuning stop pulse.

#### Features

- Internal demodulation
- Search tuning stop signal
- Low total harmonic distortion
- Minimal IF leakage at the AF output
- 2-stage integrated low pass filter

#### Maximum ratings

Supply voltage	$V_S$	15	V
Junction temperature	$T_J$	150	$^{\circ}\text{C}$
Storage temperature range	$T_{stg}$	-40 to 125	$^{\circ}\text{C}$
Thermal resistance (system-air)	$R_{thSA}$	70	K/W

#### Operating range

Supply voltage range	$V_S$	7 to 15	V
Ambient temperature range	$T_{amb}$	-25 to 85	$^{\circ}\text{C}$

# TDA 4001

**Characteristics** ( $V_S = 12\text{ V}$ ;  $T_{amb} = 25^\circ\text{C}$ ;  $V_{IRF} = 1\text{ mV}_{rms}$ ;  $R_g = 50\ \Omega$ ;  $f_{RF} = 1\text{ MHz}$ ; referred to measurement circuit)

		min	typ	max	
Current consumption			15		mA
AF output voltage	$m = 0.8$		800		mV
	$m = 0.3$		300		mV
	$V_{IRF rms} = 15\ \mu\text{V}$ ; $m = 0.8$	150		320	mV
	$20\ \log(V_{QAF rms}/30\ \text{mV} : V_{QAF rms}/1\ \text{mV})$			3	dB
Total harmonic distortion	$m = 0.8$			2	%
	$m = 0.3$			1	%
	$V_{IRF rms} = 30\ \text{mV}$ ; $m = 0.8$			5	%
Signal-to-noise ratio			6		dB
( $m = 0.3$ ; $V_{IRF rms} = 10\ \mu\text{V}$ )				46	dB
( $m = 0.3$ ; $V_{IRF rms} = 1\ \text{mV}$ )					dB
Reference voltage	$V_{stab}$		4.8		V
Oscillator voltage	$V_{OSC pp}$		100		mV
Counter output voltage	$V_{QC pp}$		100		mV
Input impedance RF input	$Z_{IRF}$		10/1.5		k $\Omega$ /pF
IF amplifier	$Z_{IF}$		3.3/1.5		k $\Omega$ /pF
AFC offset current without signal	$I_{AFC}$			$\pm 10$	$\mu\text{A}$
AFC offset current in the whole control range	$\Delta I_{AFC}$			$\pm 10$	$\mu\text{A}$
AFC output current	$I_{AFC}$		$\pm 80$		$\mu\text{A}$
( $f_{RF} = 1\text{ MHz} \pm 3\text{ kHz}$ )					
Search tuning stop output current	$I_{Q13}$		2		mA
Search tuning stop output voltage	$V_{Q13}$			0.4	V
Search tuning stop output voltage					V
( $V_{IRF} = 0\text{ V}$ )	$V_{Q13}$	11			V
( $f_{RF} > 1\text{ MHz} + 3\text{ kHz}$ )	$V_{Q13}$	11			V
( $f_{RF} < 1\text{ MHz} - 3\text{ kHz}$ )	$V_{Q13}$	11			V

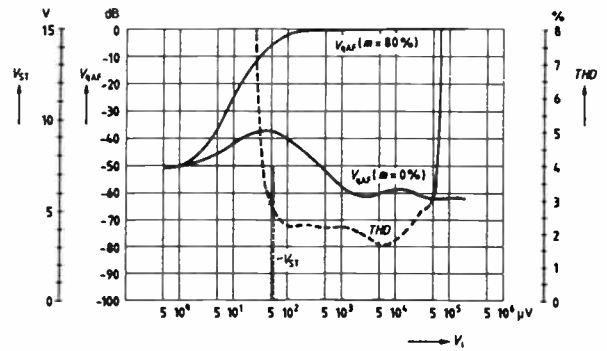
### Additional data with respect to application<sup>1)</sup>

IF suppression	$a_{IF}$	40			dB
3 dB limit frequency of the integrated TP	$f_G$	5			kHz
Conversion gain	$G_C$	30			dB
AGC IF amplifier	$V_{IF rms}$	100			$\mu\text{V}$
Control range ( $\Delta V_{QAF} = 6\text{ dB}$ )	$a$	60			dB
Input sensitivity ( $V_{QAF}/V_{IRF rms} = 1\ \text{mV} - 3\text{ dB}$ )	$V_{IRF rms}$	30			$\mu\text{V}$

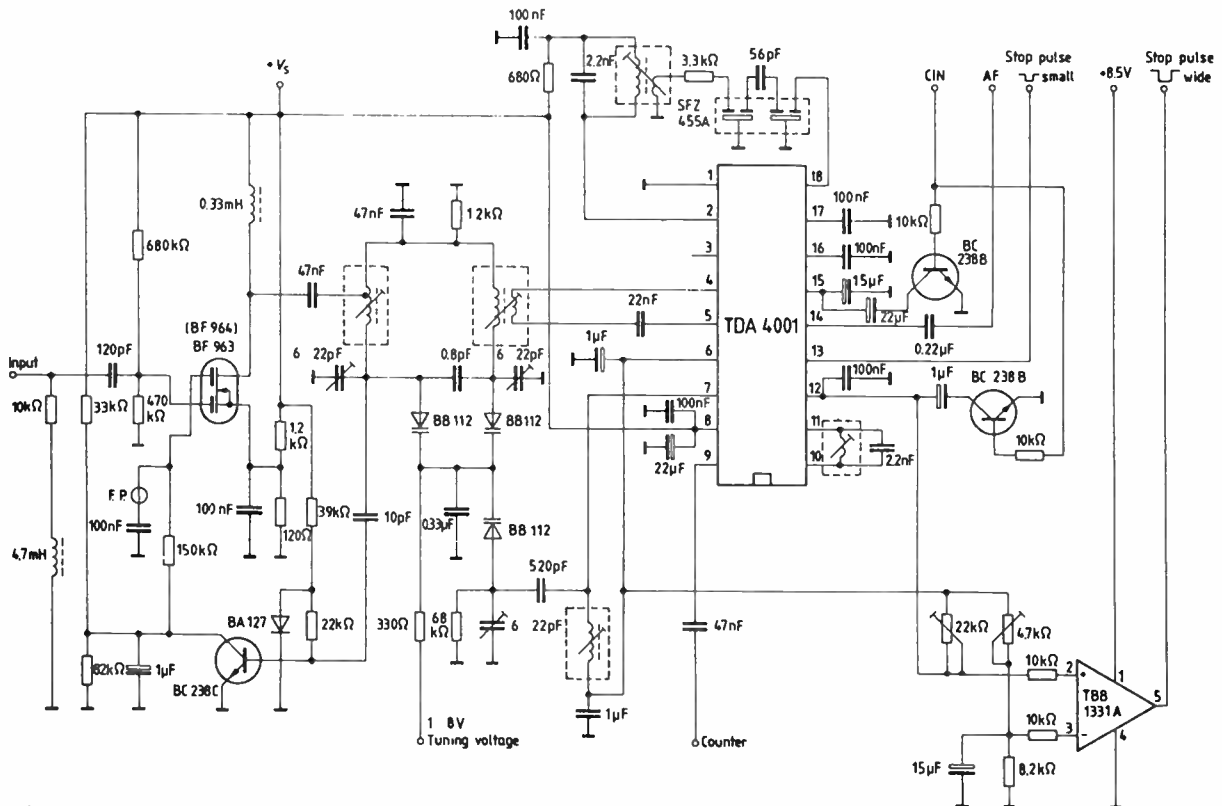
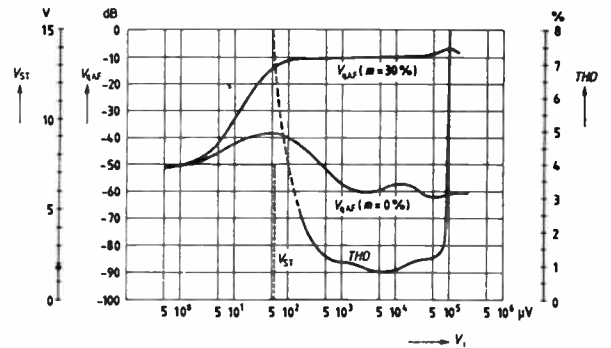
### Circuit description

The impedance converter forwards the input signal  $V_{IRF}$  to the symmetrical double balanced mixer. Subsequently the signal is converted to IF with the amplitude-controlled oscillator. An external filter forwards the IF signal to the controlled IF amplifier. The amplifier IF signal and the carrier signal will be converted to AF in the subsequent synchronous demodulator (SD). The 2-stage low pass filter forwards the available AF to the AF output. Via an additional limiter amplifier (LA), the AF uses the carrier signal to control the coincidence demodulator (CD). The output signal of the coincidence demodulator provides the stop pulse during exact tuning and sufficient field strength. The stop pulse interrupts the automatic search tuning.

AF output voltage, total harmonic distortion, search tuning stop versus input voltage  
 $V_S = 15\text{ V}$ ,  $f_{mod} = 1\text{ kHz}$ ,  $f = 1\text{ MHz}$   
0dB  $\pm$  775 mV (rms)



AF output voltage, total harmonic distortion, search tuning stop versus input voltage  
 $V_S = 15\text{ V}$ ,  $f_{mod} = 1\text{ kHz}$ ,  $f = 1\text{ MHz}$   
0dB  $\pm$  775 mV (rms)



# FM IF Amplifier with Demodulator for Radio Receivers

TDA 1047

Bipolar circuit

FM-IF amplifier for radio sets with 8-stage amplifier and symmetrical coincidence demodulator. The TDA 1047 additionally offers provisions for feeding an amplitude indicator and either positive or negative mono-stereo voltage as well as an AFT output (push-pull current output) with automatic switch-off. The included squelch can be adjusted within an input signal range of more than 40 dB and depends on detuning.

## Features

- Excellent limiting qualities
- Excellent frequency stability of demodulator characteristic
- Large range of operating voltage between 4 and 18 V
- Low current consumption
- Externally adjustable squelch
- Few external components

## Maximum ratings

Supply voltage	$V_S$	18	V
Junction temperature	$T_j$	150	°C
Storage temperature range	$T_{stg}$	-40 to 125	°C
Thermal resistance (system-air)	$R_{thSA}$	90	K/W

## Operating range

Supply voltage range	$V_S$	4 to 18	V
Frequency range	$f$	0 to 15	MHz
Ambient temperature range	$T_{amb}$	-25 to 85	°C

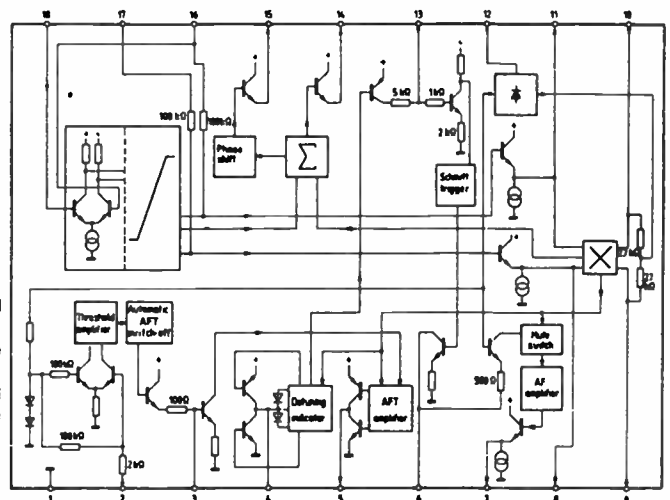
Characteristics ( $V_S = 12\text{ V}$ ;  $T_{amb} = 25\text{ °C}$ ;  $f_i = 10.7\text{ MHz}$ ;  $f_{mod} = 1\text{ kHz}$ ;  $\Delta f = \pm 75\text{ kHz}$ ;  $Q_B$  approx. 20) see test circuit

		min	typ	max	
Current consumption ( $I_{14} = 0$ )	$I_{12}$	9	12	15	mA
Voltage for field strength indicator ( $R_{14} = 3.3\text{ k}\Omega$ )	$V_{14}$	1.6	2		V
$V_{14} = 160\text{ mV}$	$V_{14}$		10	20	mV
$V_{14} = 16\text{ }\mu\text{V}$	$I_{14}$			3.6	mA
Current					
Voltage for squelch adjustment (approx. log.)	$V_{15}$		0		V
$V_{15} = 8\text{ mV}$	$V_{15}$	2.2	2.5		V
$V_{15} = 16\text{ }\mu\text{V}$	$I_{15}$			3.6	mA
Current					
AF output DC voltage	$V_7$		2.1		V
AF output voltage ( $V_1 = 10\text{ mV}$ ; $THD = 0.4\%$ )	$V_{7,rms}$		270	300	mV
Internal DC voltage of output emitter follower	$I_7$		180	200	$\mu\text{A}$
Total harmonic distortion ( $V_1 = 10\text{ mV}$ ) <sup>1)</sup>	$THD$		0.4	0.8	%
Input voltage for limiting <sup>2)</sup>	$V_1$		30	50	$\mu\text{V}$
Input resistance	$R_{1,18}$		10		$\text{k}\Omega$
AF output resistance <sup>3)</sup> (emitter follower output)	$R_{Q7}$		0.3	1	$\text{k}\Omega$
Threshold of detuning-dependent squelch (referred to $f = 10.7\text{ MHz}$ )	$\Delta f$		$\pm 100$	$\pm 150$	kHz
Switching threshold for AFT OFF	$V_2$			20	mV
Input resistance	$R_{1,2}$		40	100	$\text{k}\Omega$
Voltage for AFT OFF	$V_3$		0.8		V
Current deviation of the AFT output	$\Delta I_5$		$\pm 150$		A
IF output voltage for limiting	$V_{9,11,pp}$		500		mV
Input resistance for demodulator circuit	$R_{9,10}$		5.4		$\text{k}\Omega$
Recommended voltage for demodulator circuit <sup>4)</sup>	$V_{9,10,pp}$		500		mV
Threshold for AF OFF	$V_{13}$		0.85	0.95	V
AF ON	$V_{13}$	0.5	0.6		V
Hysteresis for switching threshold	$\Delta V_{13}$		120	200	mV
Internal resistance for AF switch-off time constant	$R_{Q8}$		500		$\Omega$
AM suppression ( $V_1 = 10\text{ mV}$ ; $m = 30\%$ )	$\theta_{AM}$		60		dB
Signal-to-noise-ratio ( $V_1 = 10\text{ mV}$ )	$\theta_{S/N}$		70		dB
AF suppression at muting circuit ( $V_1 = 10\text{ mV}$ )	$\theta_{AF}$		60		dB

## Pin configuration

Pin No.	Function
1	Ground
2	Sensor input for AFT switch off
3	AFT switch-off time constant
4	Low-pass capacitor for detuning-dependent AF switch off
5	AFT output (push-pull output)
6	Low-pass capacitor for suppression of switch off clicks in case of detuning and insufficient field strength
7	AF output (emitter follower with constant-current source)
8	Output of limiter amplifier
9	Phase shifting circuit
10	
11	Output of limiter amplifier
12	Positive operating voltage
13	Input for amplitude-dependent switch off
14	Instrument connection and stereo switching voltage (positive going)
15	Squelch and stereo switching voltage (negative going)
16	Feedbacks for IF amplifier
17	
18	IF input

## Block diagram



1) In the case of using a band filter:  $THD_{max} = 0.3\%$

2) Limiting application for  $V_{AF} = -3\text{ dB}$

3) The output resistance  $R_{Q7}$  can be reduced by connecting a resistor of at least  $2.7\text{ k}\Omega$  between pin 7 and ground.

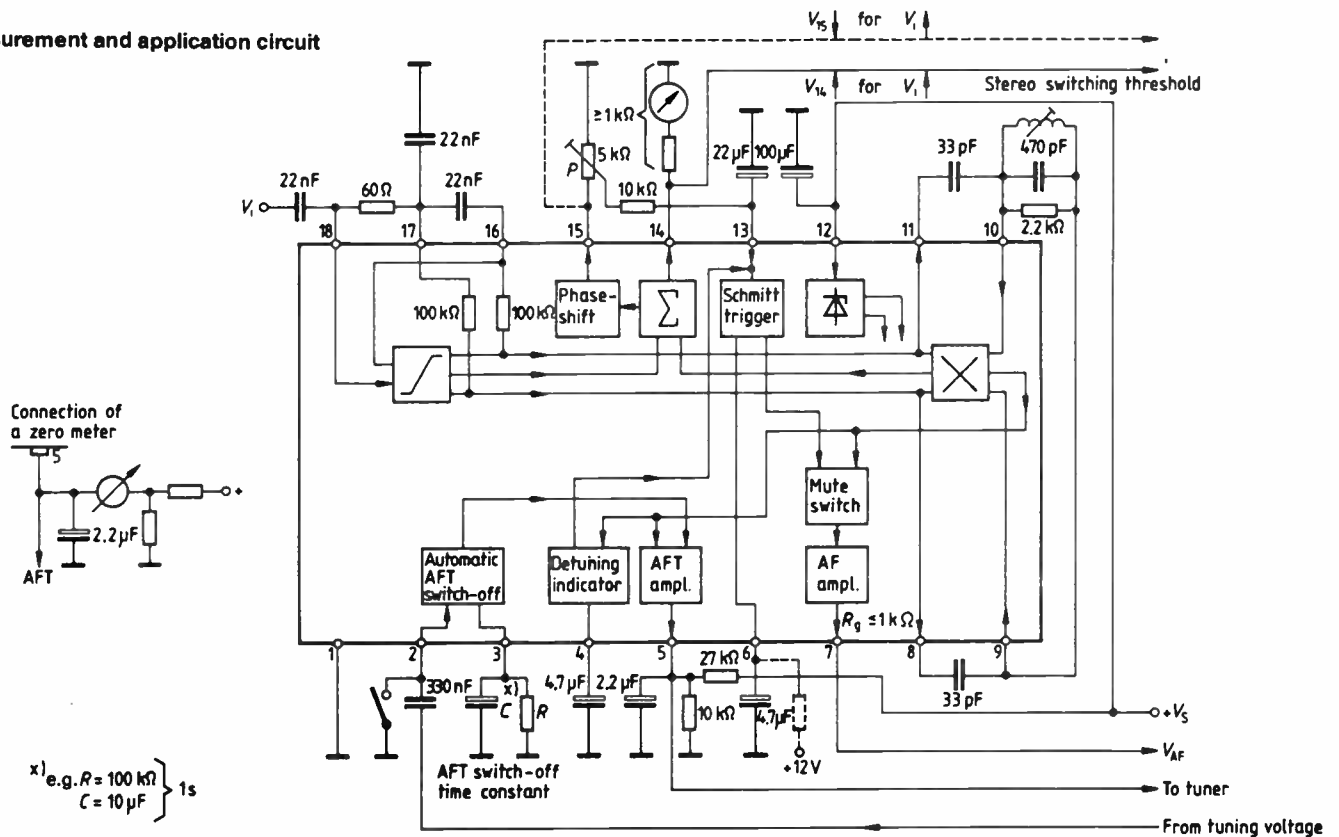
4) The recommended voltage at the demodulator circuit  $V_{9,10}$  can be adjusted by the capacitors  $C_{9,9}$  and  $C_{10,11}$ , which are also influencing the voltage  $V_{14}$  and  $V_{15}$ .

If the slider of potentiometer  $P$  is grounded, the field-strength-dependent squelch is switched off.

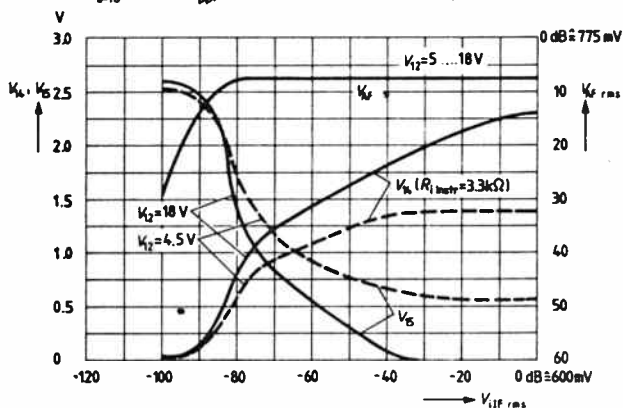
If pin 13 is grounded, both the field-strength- and the detuning-dependent squelch are switched off.

The noise level between the transmitters becomes more or less audible, when pin 6 is loaded with a resistance to  $+12\text{ V}$  in case of "squelch on". Noise attenuation increases with the size of the resistance ( $R \geq 10\text{ k}\Omega$ ).

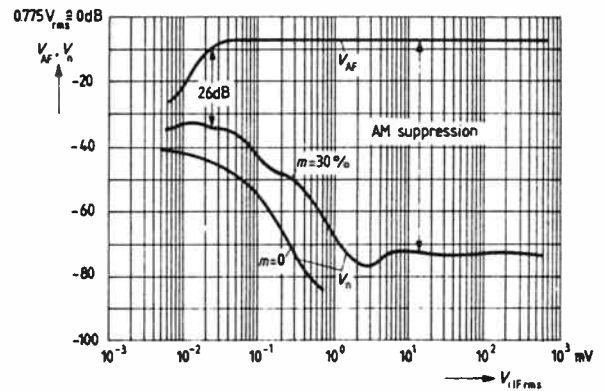
## Measurement and application circuit



AF output voltage, indicator voltage, squelch voltage versus input voltage  
 $V_{12} = 15 \text{ V}$ ;  $f = 10.7 \text{ MHz}$ ,  $\Delta f = \pm 75 \text{ kHz}$ ,  $f_{\text{mod}} = 1 \text{ kHz}$   
 $V_{9-10} = 500 \text{ mV}_{\text{pp}}$ , wideband-measured at  $100 \text{ nF}$ ,  $\text{THD} = 0.4\%$



AF output voltage, noise voltage versus input voltage  
 $f = 10.7 \text{ MHz}$ ,  $\Delta f = \pm 75 \text{ kHz}$ ,  $V_{12} = 15 \text{ V}$



# LED Array Drivers

## LED Driver for Light Spot Displays

Bipolar circuit

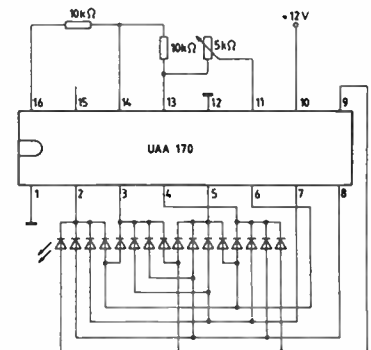
UAA 170

### Maximum ratings

Supply voltage	$V_S$	18	V
Input voltages	$V_{11}, V_{12}, V_{13}$	6	V
Load current	$I_{14}$	5	mA
Junction temperature	$T_j$	150	$^{\circ}\text{C}$
Storage temperature range	$T_{\text{stg}}$	-40 to 125	$^{\circ}\text{C}$
Thermal resistance (system-air)	$R_{\text{th,SA}}$	90	K/W

### Operating range

Supply voltage range (LED red <sup>1)</sup> )	$V_S$	11 to 18	V
Ambient temperature range	$T_{\text{amb}}$	-25 to 85	$^{\circ}\text{C}$



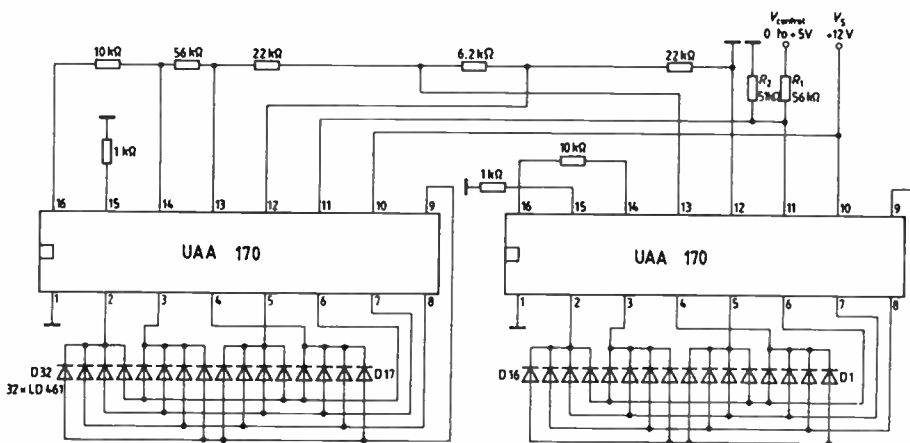
## UAA 170

IC for driving 16 light emitting diodes. Depending on the input voltage, the individual LEDs are driven within one row in form of a light spot. The UAA 170 provides a linear relation between control voltage and the driven LED.

By using an appropriate circuitry, the brightness of the LEDs can be varied and the crossing over of the light spot can be set between "smooth" and "abrupt". By connecting two ICs in parallel, up to 30 LEDs can be driven.

**Characteristics** ( $V_S = 12\text{ V}$ ;  $T_{amb} = 25\text{ }^\circ\text{C}$ )

	min	typ	max		
Current consumption ( $I_{14} = 0$ ; $I_{16} = 0$ )					
Control input current	$I_S$	2	4	10	mA
Reference input current	$I_{11}$	-2			$\mu\text{A}$
	$I_{12}, I_{13}$	-2			$\mu\text{A}$
Voltage difference	$\Delta V_{12/13}$	1.4		6	V
Voltage difference for smooth light transition	$\Delta V_{12/13}$	1.4			V
Voltage difference for abrupt light transition	$\Delta V_{12/13}$	4			V
Voltage difference	$\Delta V_{12/13}$	4			V
Stabilized voltage $I_{14} = 300\text{ }\mu\text{A}$	$V_{14}$		5	6	V
$I_{14} = 5\text{ mA}$	$V_{14}$	4.5			V
Reference input voltage	$V_{ref\ max}$	1.4		6	V
	$V_{ref\ min}$	0		4.6	V
Tolerance of forward voltages of LEDs, mutually	$\Delta V_D$			0.5	V
Output current for LEDs	$\Sigma I_D$		25		mA



### Application circuit for the control of 30 LEDs with 2 x UAA 170

Range of control voltage  $V_{control} = 0$  to  $5\text{ V}$   
 Voltage difference  $V_{12/13} = 2 \times 1.2\text{ V} = 2.4\text{ V}$   
 Since the diodes D16 or D17 are permanently lit when the maximum or minimum voltages  $V_{13}$  or  $V_{12}$  adjusted by  $R_3, R_4, R_5$ , are exceeded or fall short the diodes should be covered, if necessary.

## LED Driver for Light Band Displays

Bipolar circuit UAA 180

Integrated circuit for driving 12 light emitting diodes. Corresponding to the input voltage the LEDs forming a light band are controlled similar to a thermometer scale.

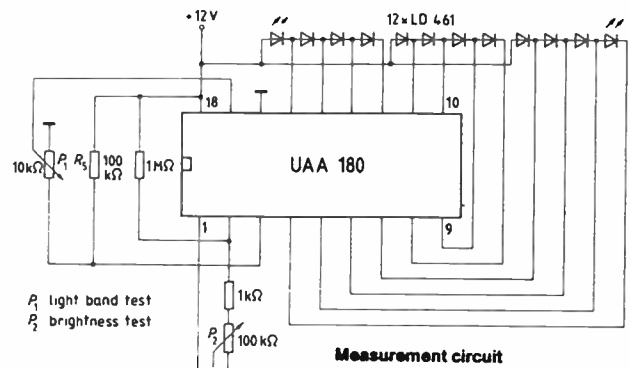
By using an appropriate circuitry the brightness of the LEDs can be varied and the light passage between two adjacent LEDs can be arranged between "smooth" and "abrupt".

### Maximum ratings

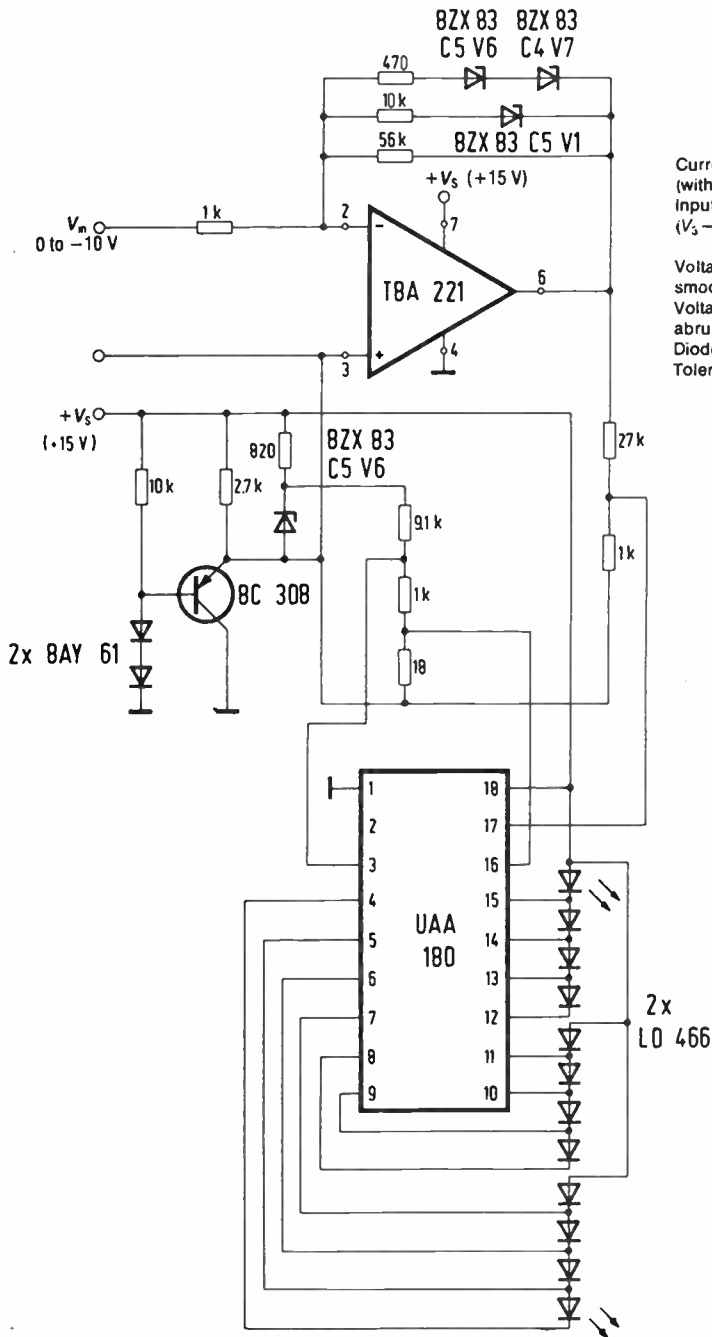
Supply voltage	$V_S$	18	V
Input voltage	$V_3$	6	V
	$V_{16}$	6	V
	$V_{17}$	6	V
Storage temperature range	$T_{stg}$	-40 to 125	$^\circ\text{C}$
Junction temperature	$T_j$	150	$^\circ\text{C}$
Thermal resistance (system-air)	$R_{th\ SA}$	78	K/W

### Operating range

Supply voltage range	$V_S$	10 to 18	V
Ambient temperature range	$T_{amb}$	-25 to 85	$^\circ\text{C}$







## UAA 180

Characteristics ( $V_S = 12\text{ V}$ ,  $T_{amb} = 25^\circ\text{C}$ )

	min	typ	max	
Current consumption ( $I_2 = 0$ ) (without LED current)		5.5	8.2	mA
Input currents ( $V_S - V_{16} < 2\text{ V}$ )		0.3	1	$\mu\text{A}$
		0.3	1	$\mu\text{A}$
		0.3	1	$\mu\text{A}$
Voltage difference for smooth light transition	1			V
Voltage difference for abrupt light transition	4			V
Diode current per diode		10		mA
Tolerance of LED forward voltages			1	V

## Level Meter with Logarithmic Scale Using UAA 180

Fig. 4.8 shows a circuit of a level meter with an LED-array for indication. The input signal is applied via a pre-resistor to the operational amplifier TBA 221. The logarithmic characteristic is realized by 3 resistors and 3 z-diodes being part of the reverse feedback circuit. Contrary to the common circuits already described in "Design Examples for Semiconductor Circuits, Edition 76/77, Section 4.10.1" this one operates with only one power supply. A network consisting of the two diodes BAY 61 and the transistor BC 308 sets a bias of approx. 2 V to the non-inverting input of the operational amplifier. This voltage is also the reference for the UAA 180 and for the 27 k/1 k $\Omega$ -divider connected to the output of the operational amplifier. This reference voltage is slightly increased by a 18  $\Omega$ -resistor to decrease the threshold for the first light spot. The upper level of the reference voltage is generated by the 9.1 k/1 k $\Omega$ -divider and the voltage of 5.6 V being stabilized by the z-diode BZX 83 C5V6.

With the described circuit a good conformity to a logarithmic characteristic is achieved and the indicated level increases by 5 dB from one light spot to another.

## Components for circuit 4.8

1 IC	UAA 180
1 Operational amplifier	TBA 221
1 Transistor	BC 308
2 LED-arrays	LD 466
2 Z-diodes	BZX 83 C5 V6
1 Z-diode	BZX 83 C5 V1
1 Z-diode	BZX 83 C4 V7
2 Diodes	BAY 61

# SWITCHED-MODE POWER SUPPLIES

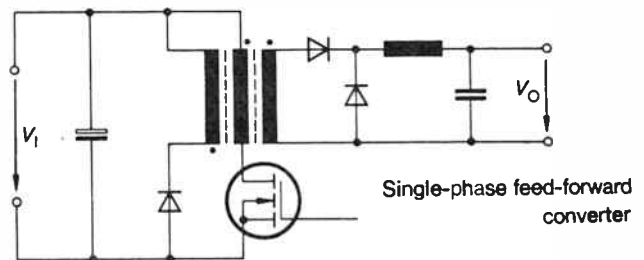
Owing to their high efficiency, their low weight and volume Switched-Mode Power Supplies (SMPS) find increasing use in device power supply applications.

This development is aided by new, more efficient active and passive components, such as the SIPMOS transistor and special, highly integrated control and regulating circuits.

This permits a far-reaching standardization of SMPS and a simplification of their circuit technology. The development costs are decreased, so that even small quantities become economically feasible.

The integrated control and regulating devices for SMPS, the TDA 4700, TDA 4718, TDA 4716, and TDA 4714 can be used to implement all common principles of SMPS, such as single-phase converters (flyback, forward, choke converter) and push-pull converters in normal, half-bridge and full-bridge circuits with few external components.

The TDA 4700 IC exhibits the widest range of functions. The other devices are adapted to the different SMPS concepts by omitting various functional parts.



permit the construction of high quality devices with a high degree of operational reliability.

With all the ICs, a facility that is worthy of special mention is that of feed-forward control (50/60 Hz hum suppression) with a separate ramp generator.

Types TDA 4700 and TDA 4718 have a PLL synchronization circuit with a frequency capture range of  $\pm 30\%$ .

In order to achieve symmetry in push-pull SMPS, the TDA 4700 offers connection capability for an external symmetry correction circuit.

# SWITCHED-MODE POWER SUPPLIES

Control IC for Single-Ended and Push-Pull Switched-Mode Power Supplies

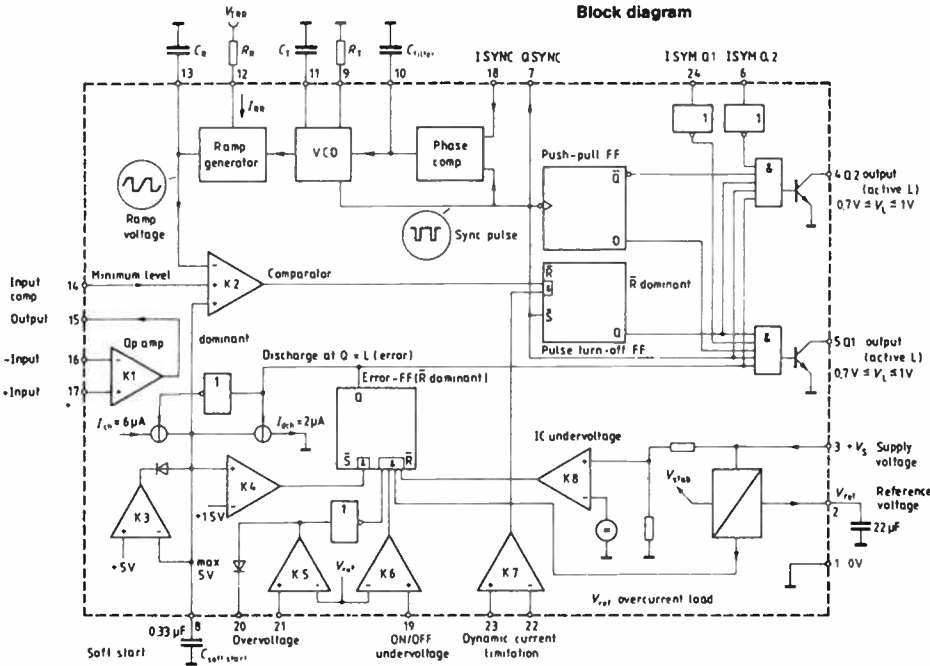
Bipolar IC

TDA 4700  
TDA 4700 A

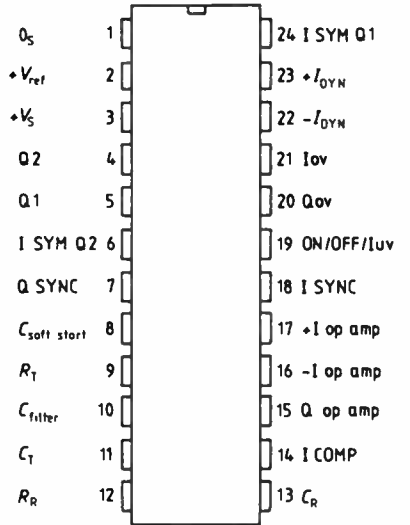
This versatile SMPS control IC comprises digital and analog functions which are required to design high-quality flyback, single-ended and push-pull converters in normal, half-bridge and full-bridge configurations. The component can also be used in single-ended voltage multipliers and speed-controlled motors. Malfunctions in electrical operation are recognized by the integrated operational amplifiers and activate protective functions.

In addition to the noticeable reduction in components, our SMPS ICs offer a number of advantages:

- Feed-forward control (line hum suppression)
- Symmetry inputs for push-pull converter
- Dynamic output current limitation
- Overvoltage protection
- Undervoltage protection
- Soft start
- Double pulse suppression



Pin configuration, top view



Pin designation

Pin No.	Function
1	Os
2	Reference voltage $V_{ref}$
3	Supply voltage $V_S$
4	Output Q 2
5	Output Q 1
6	Symmetry Q 2
7	Sync. output
8	Soft start $C_{soft\ start}$
9	VCO $R_T$
10	Capacitance $C_{filter}$
11	VCO $C_T$
12	Ramp generator $R_R$
13	Ramp generator $C_R$
14	Comparator input
15	Operational amplifier output
16	Operational amplifier input (-)
17	Operational amplifier input (+)
18	Sync. input
19	ON/OFF, undervoltage
20	Overvoltage output
21	Overvoltage input
22	Dynamic current limitation (-)
23	Dynamic current limitation (+)
24	Symmetry Q 1

## Maximum ratings

	Notes	Lower limit B	Upper limit A	
Supply voltage	$V_S$	-0.3	33	V
Voltage at Q1, Q2	$V_O$	-0.3	33	V
Current at Q1, Q2	$I_O$	-0.3	70	mA
Symmetry 1, 2	$V_{SYM}$	-0.3	33	V
Sync output	$V_{SYNC0}$	-0.3	7	V
	$I_{SYNC0}$	0	10	mA
	$V_{SYNC1}$	-0.3	33	V
Sync input	$V_{IC}$	-0.3	7	V
Input $C_{filter}$	$V_{IRT}$	-0.3	7	V
Input $R_T$	$V_{ICT}$	-0.3	7	V
Input $C_T$	$V_{IRR}$	-0.3	7	V
Input $R_R$	$I_{ICR}$	-10	10	mA
Input $C_R$				
Input comparator				
K 2, K 5, K 6, K 7	$V_{IK}$	-0.3	33	V
Output K 5	$V_{OK5}$	-0.3	33	V
Input op amp	$V_{Iop\ amp}$	-0.3	33	V
Output op amp	$V_{Oop\ amp}$	-0.3	$V_S - 1$	V
			max. 7	V
Reference voltage	$V_{ref}$	-0.3	$V_{ref}$	V
Input $C_{soft\ start}$	$V_{Isoft\ start}$	-0.3	7	V

## Operating range

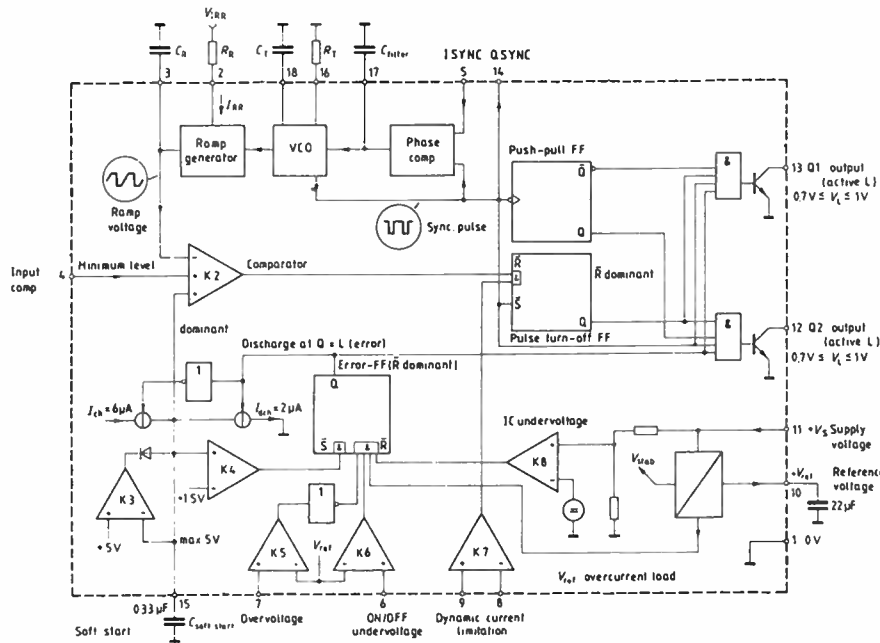
		10.5	30	V	
Supply voltage	$V_S$				
Ambient temperature					
	TDA 4700	$T_{amb}$	-25	85	°C
	TDA 4700 A	$T_{amb}$	0	70	°C
VCO frequency	$f$	40	250 000	Hz	
Ramp generator frequency	$f_{RG}$	40	250 000	Hz	

# Control IC for Single-Ended and Push-Pull Switched-Mode Power Supplies

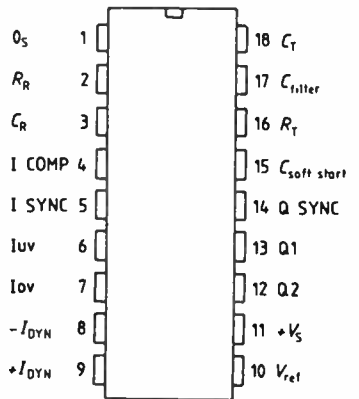
Bipolar IC **TDA 4718**  
**TDA 4718 A**

This 18-pin SMPS control IC comprises digital and analog functions which are required to design high-quality flyback, single-ended, and push-pull converters in normal and half-bridge configurations. In addition to the control functions, the circuit contains operational amplifiers which detect malfunctions during electrical operation and suitable protective measures. A PLL circuit for synchronization is one of the special advantages offered by this IC in addition to the following features:

- Feed-forward control (line hum suppression)
- Push-pull outputs
- Dynamic current limitation
- Overvoltage protection
- Undervoltage protection
- Soft start
- Double pulse suppression



## Pin configuration top view



## Pin designation

### Pin No. Function

Pin No.	Function
1	O <sub>S</sub>
2	Ramp generator R <sub>R</sub>
3	Ramp generator C <sub>R</sub>
4	+ input comparator K 2
5	Sync input
6	Input undervoltage, ON/OFF
7	Input overvoltage
8	Input dynamic current limitation (-)
9	Input dynamic current limitation (+)
10	Reference voltage V <sub>ref</sub>
11	Supply voltage V <sub>S</sub>
12	Output Q 2
13	Output Q 1
14	Sync output
15	Soft start
16	VCO R <sub>T</sub>
17	Capacitance C <sub>filter</sub>
18	VCO C <sub>T</sub>

## Maximum ratings

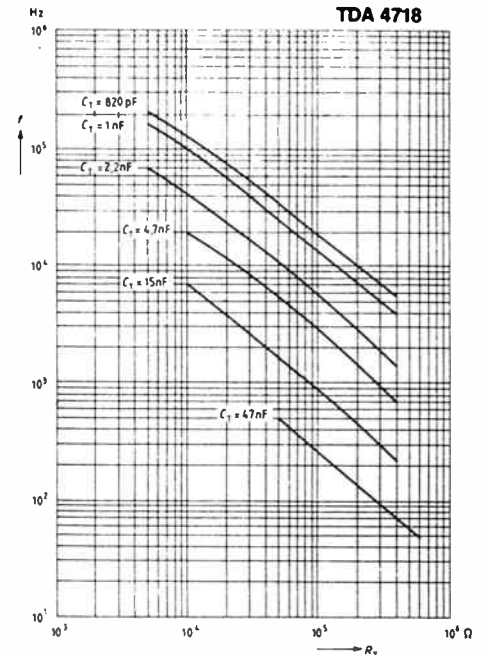
	Notes	Lower limit B	Upper limit A	
Supply voltage	V <sub>S</sub>	-0.3	33	V
Voltage at Q1, Q2	V <sub>O</sub>	-0.3	33	V
Current at Q1, Q2	I <sub>O</sub>	-0.3	70	mA
Sync output	V <sub>SYNCO</sub>	-0.3	7	V
	I <sub>SYNCO</sub>	0	10	mA
Sync input	V <sub>SYNCI</sub>	-0.3	33	V
Input C <sub>filter</sub>	V <sub>1CI</sub>	-0.3	7	V
Input R <sub>T</sub>	V <sub>1RT</sub>	-0.3	7	V
Input C <sub>T</sub>	V <sub>1CT</sub>	-0.3	7	V
Input R <sub>R</sub>	V <sub>1RR</sub>	-0.3	7	V
Input C <sub>R</sub>	I <sub>1CR</sub>	-10	10	mA
Input comparator K2, K5, K6, K7	V <sub>1K</sub>	-0.3	33	V
Output K5	V <sub>O K5</sub>	-0.3	33	V
Reference voltage	V <sub>ref</sub>	-0.3	V <sub>ref</sub>	V
Input C <sub>soft start</sub>	V <sub>1soft start</sub>	-0.3	7	V

## Operating range

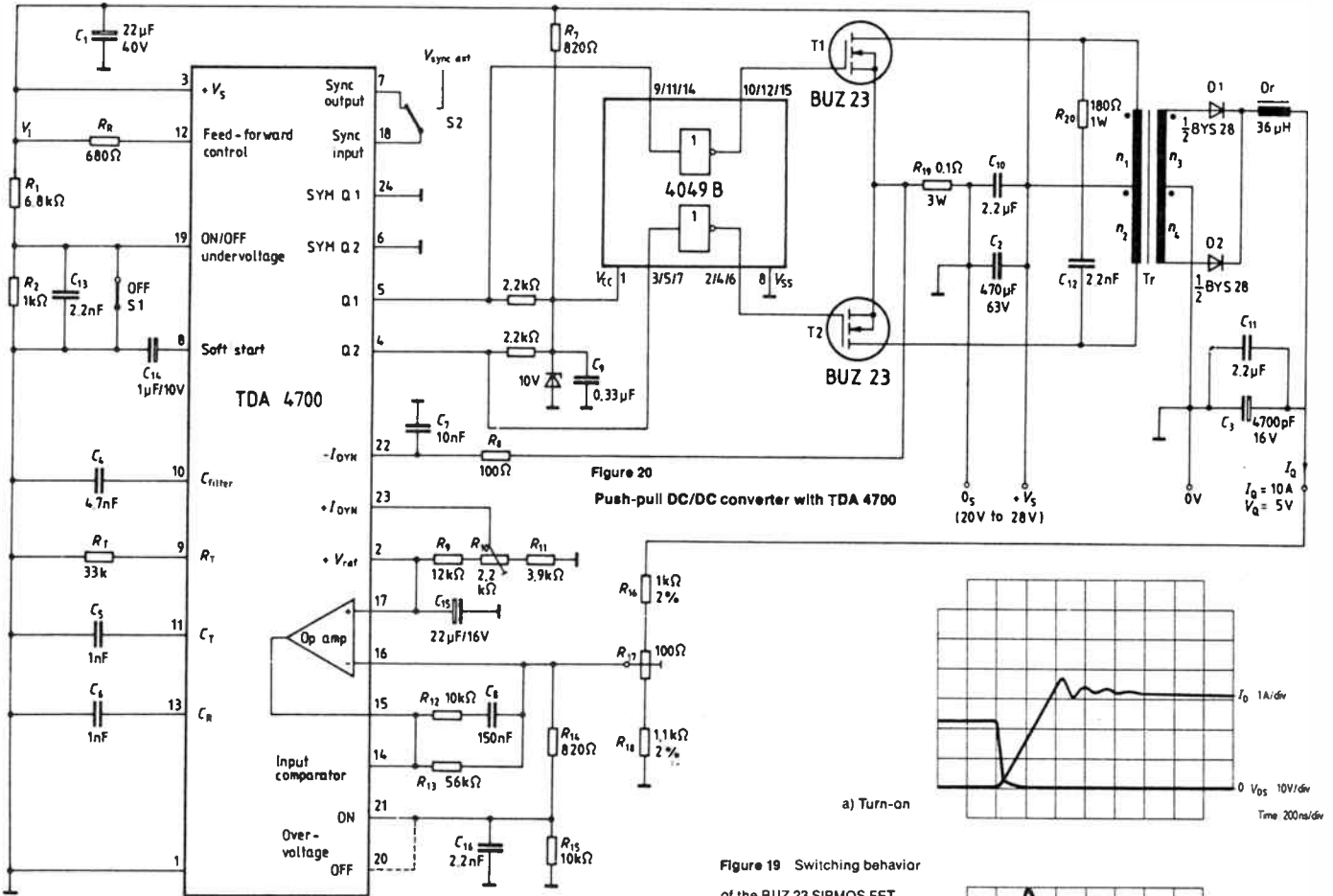
	V <sub>S</sub>	10.5	30	V
Supply voltage	V <sub>S</sub>	10.5	30	V
Ambient temperature	T <sub>amb</sub>	-25	85	°C
	T <sub>amb</sub>	0	70	°C
Max. VCO frequency	f	40	250 000	Hz
Ramp generator frequency	f <sub>RG</sub>	40	250 000	Hz

VCO frequency versus R<sub>T</sub> and C<sub>T</sub>

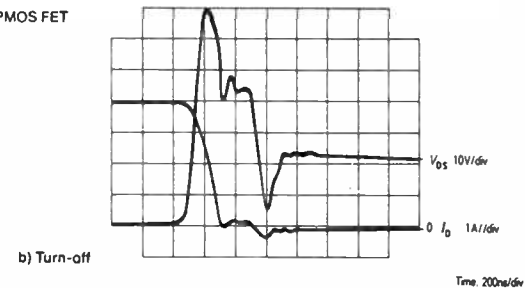
**TDA 4700**  
**TDA 4718**



# SWITCHED-MODE POWER SUPPLIES



**Figure 19** Switching behavior of the BUZ 23 SIPMOS FET



**Table 2** Components list of the DC/DC converter

Capacitors/seq. No.	Type	Ordering code
C <sub>1</sub>	Tantalum electrolytic capacitor	B45181-B4226-M
C <sub>2</sub>	Al electrolytic capacitor	B41010-D8477-T
C <sub>3</sub>	Al electrolytic capacitor	B41336-A4478-T
C <sub>4</sub>	MKT stacked-film capacitor	B32560-D6472-K
C <sub>5</sub>	MKT stacked-film capacitor	B32560-D6102-J
C <sub>6</sub>	MKT stacked-film capacitor	B32560-D6102-J
C <sub>7</sub>	MKT stacked-film capacitor	B32560-D6103-K
C <sub>8</sub>	MKT stacked-film capacitor	B32560-D1154-J
C <sub>9</sub>	MKT stacked-film capacitor	B32560-D1334-K
C <sub>10</sub>	MKT stacked-film capacitor	B32563-D3225-K
C <sub>11</sub>	MKT stacked-film capacitor	B32563-D3225-K
C <sub>12</sub>	MKT stacked-film capacitor	B32560-D6222-K
C <sub>13</sub> = C <sub>16</sub>	MKT stacked-film capacitor	B32560-D6222-K
C <sub>14</sub>	Tantalum electrolytic capacitor	B45181-C4105-M
C <sub>15</sub>	Tantalum electrolytic capacitor	B45181-B2226-M

**Transformer Tr**

Core: EC 41 ferrite N 27, ungapped

Coil former:

Mounting assembly:

Winding: prim: n<sub>1</sub> = n<sub>2</sub> = 14 turns

sec: n<sub>3</sub> = n<sub>4</sub> = 5 turns

n<sub>1</sub>/n<sub>2</sub> and n<sub>3</sub>/n<sub>4</sub>

parallel-wound with litz wire 120 × 0.1 CuLs

**Choke Dr**

Core: RM 12 ferrite N 41 A<sub>L</sub> = 160

Coil former:

Clamps: 2 are required

Winding: 15 turns

2 × litz wire 100 × 0.1 CuLs

Inductance: 36 μH

**Heat sinks**

BUZ 23: 10 K/W

BYS 15: 2.3 K/W (mounted together)

**Table 1** Technical data

	min	typ.	max	Units	
Input voltage	V <sub>i</sub>	20	24	28	V
Current consumption	I <sub>i</sub>		42		mA
			2.7		A
				10 A	
Primary current	I <sub>prim</sub>		4		A
				10 A	
Output current	I <sub>O</sub>	0		10	A
Duty cycle			0.4		
				10 A	
Output voltage	V <sub>O</sub>		5	5.75	V
Stationary behavior:					
Load regulation ( $\frac{\Delta V_O}{\Delta I_O} \cdot \frac{10 A}{5 V}$ )			0.2		%
I <sub>O</sub> > 10 mA					
Output voltage regulation ( $\frac{\Delta V_O}{\Delta V_i} \cdot \frac{24 V}{5 V}$ )			2.4		%
Dynamic behavior:					
Overshoot if I <sub>O</sub> = 10 A → I <sub>O</sub> = 1 A		0.2			V
if I <sub>O</sub> = 10 A → I <sub>O</sub> = 3 A		0.15			V
Output ripple 40 kHz (peak-to-peak)				50	mV
Efficiency	η		81		%
Power dissipation at the SIPMOS FET	P <sub>V</sub>	1.4			W

### DC/DC converter

24 V - 5 V/10 A

$f_{osc} = 40 \text{ kHz}$  using TDA 4700 and SIPMOS transistors

The circuit in figure 20 is a finished example for a push-pull SMPS with common ground according to figure 14.

The SIPMOS types BUZ 23, driven by the CMOS standard IC 4049 B (hex inverter) are used as switching transistors. Three inverters are connected in parallel, to be able to supply a sufficiently high current for rapid recharging of SIPMOS gate capacitance. In the stationary condition, the SIPMOS transistors consume practically no control power. The SIPMOS FET can be switched at a high speed when driven in this fashion. Figure 19 shows the switching behavior (turn-on and turn-off) of the SIPMOS transistor BUZ 23 at a drain current of 4 A. The rise or fall times respectively, as well as the turn-on or turn-off delays respectively, are in the range of  $\leq 100 \text{ ns}$ .

Figure 19 shows the switching behavior (turn-on and turn-off) of the SIPMOS transistor BUZ 23 at a drain current of 4 A. The rise or fall times respectively, as well as the turn-on or turn-off delays respectively, are in the range of  $\leq 100 \text{ ns}$ .

### IC external circuitry

The short switching times keep the transistor losses low and guarantee a short reaction time of the dynamic current limiting circuit, which therefore works precisely and with a high degree of switching accuracy. For this purpose, the voltage drop of the current detection resistor  $R_1$  is led to the current limiting comparator K7 via a low pass filter to suppress the interference. The operating point of the current limiting circuit can be set with trimmer  $R_{10}$  to between 5.4 A and 8.4 A (drain current). On the secondary side, this results in output short-circuit currents of approximately 12 A to 20 A. The converter is permanently short-circuit proof at  $I_{Omax} < 15 \text{ A}$ .

The SMPS can be switched over with switch  $S_2$  from free-running operation to synchronization using an external signal  $V_{SYNCext}$ .

In order to prevent overdischarge of the battery, in the case of the converter e.g. operating on a 24 V battery, the under-

voltage shutdown is adjusted to 19.5 V by the dividing ratio  $R_1/R_2$ .

Switch  $S_1$  is used to turn the converter ON/OFF. A transistor can also be used for remote control.

The input voltage  $V_i$  is applied to the input of the feed-forward control via  $R_R$ .

An input ripple of approximately  $4 V_{op}$  is recorded each time together with the output voltage. Without feed-forward control, the 100 Hz ripple of  $V_O$  is approximately 24 mV, with feed-forward control on the other hand, only approximately 4 mV. This improvement by a factor of 6 is achieved without additional components.

$V_O$  is led to the inverting input of the regulating amplifier via the voltage divider  $R_{10}/R_{11}/R_{18}$  for the regulation of the output voltage and for the output overvoltage turn-off. Trimmer  $R_1$  serves to adjust the output voltage by approx.  $\pm 5 \%$  for the compensation of the tolerance of  $V_{ref}$ , which is applied to the

non-inverting regulating amplifier input. The combination  $R_{12}$ ,  $R_{13}$  and  $C_6$  form the feedback path of the regulating amplifier, which causes a good stability behavior with low stationary regulating deviations.

The voltage divider  $R_{14}$ ,  $R_{15}$  is dimensioned in such a way that the integrated overvoltage protection switches at approximately 15 % overvoltage and disables both switching transistors. By the connection of pin 20 and 21 (dashed), the switching transistors will continuously remain disabled after the overvoltage has occurred. The converter will only continue after it has been turned off and turned on again ( $S_1$ ), provided that the error has been eliminated by that time.

Due to the fact that SIPMOS transistors display no storage time, the dissymmetries that occur in this circuit with bifilar wound power transformer Tr are so small that a separate symmetry correction circuit is not required.

### Single-phase feed-forward converter using the TDA 4718; 220 V ac - 5 V/10 A (20 A)

Figure 23 shows the circuit arrangement of a single-phase feed-forward converter with 220 V ac input voltage and 5 V/10 A at the output. The control unit is equipped with the TDA 4718 IC, which operates at an oscillator frequency of 100 kHz. Only one output is used, which drives a SIPMOS FET via a CMOS driver 4049 B at 50 kHz. This causes the driver circuit duty cycle to be automatically limited to  $< 50 \%$ . Figure 22 shows the wiring of the individual inverters of the driver device.

The control and driver ICs are powered by the 220 V ac line almost without losses, via a capacitive series resistance consisting of the two 1  $\mu\text{F}$  capacitors. The Z diode limits the supply voltage to 12 V.

The transformer, type AZV 2125 with the ferrite core ER 42, is available fully assembled. It is rated for an output current of up to 20 A. The windings of the transformer consist of the primary winding  $n_2$ , the demagnetization windings  $n_1$  and  $n_3$ , the shield wrap  $n_4$  and the secondary winding  $n_5$ .

For current monitoring, the voltage drop at the current sensing resistor  $R_1$  caused by the source current arrives at the inverting input of the dynamic current limiting circuit, the switching threshold of which is adjustable.

The dc input voltage  $V_i$  is monitored for overvoltage and undervoltage and is fed to the ramp generator via  $R_R$  for 50/60 Hz hum suppression (feed-forward control). The SMPS can be switched on and off at the input for undervoltage.

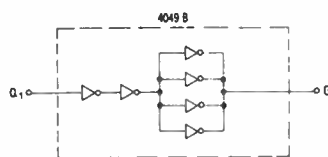


Figure 22 Wiring of driver device 4049 B in figure 23

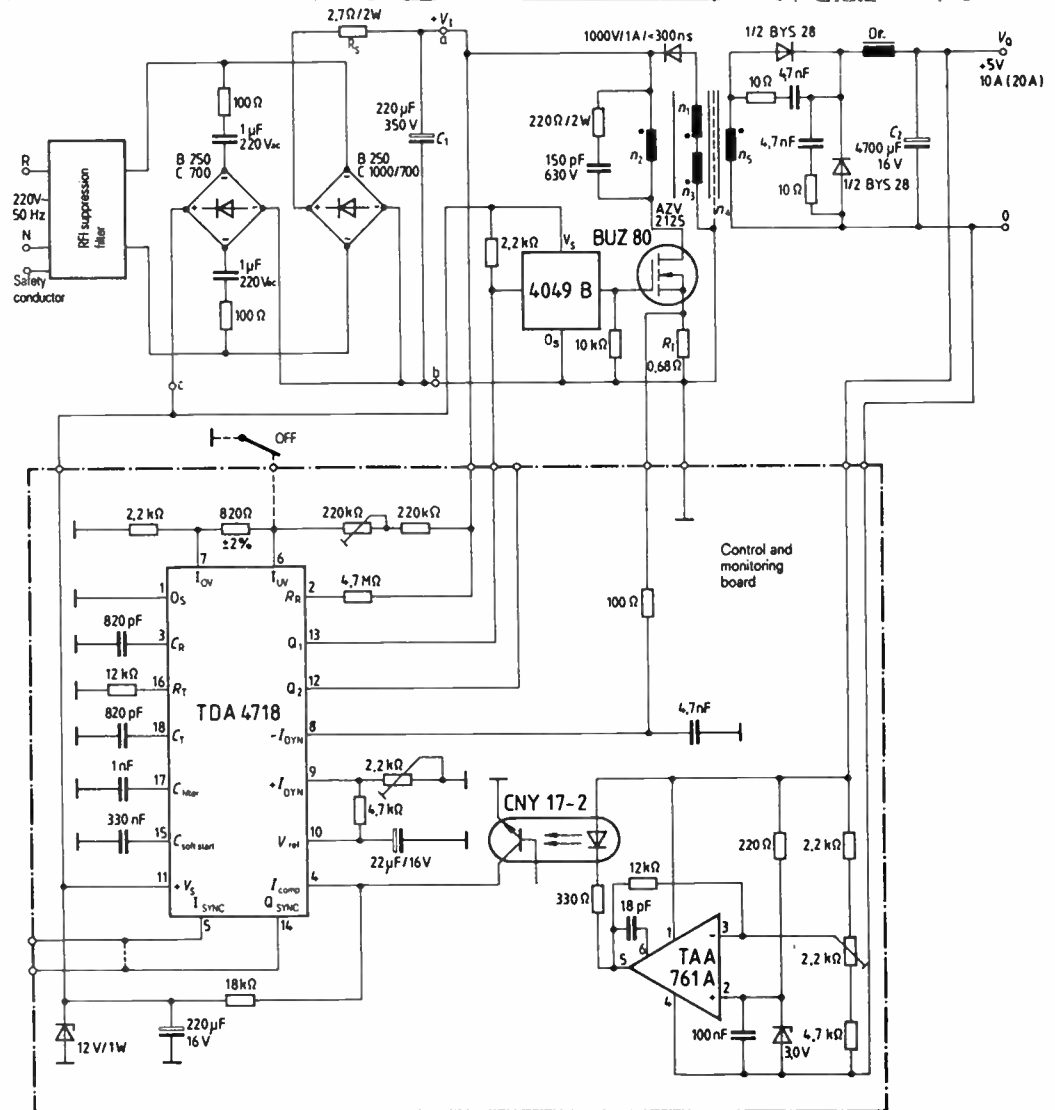


Figure 23 Single-phase SMPS 220 V ac - 5 V/10 A/50 kHz

# SWITCHED-MODE POWER SUPPLIES

A wire jumper is provided to select between external synchronization and free-running operation.

Regulation of the output voltage is obtained with potential isolation via a

separate operational amplifier and an optocoupler. The slight long-term deviation and TC of the optocoupler are compensated for by the closed control loop.

## Technical data of the single-phase feed-forward converter

Table 3

AC input voltage (rms value)	$V_{ac}$	220 <sup>+10%</sup> -15%	V
Current consumption (rms value) (at $V_{ac} = 220$ V and $I_O = 10$ A)	$I_i$	0.28	A
Output voltage	$V_O$	5	V
50 kHz ripple (peak-to-peak value)		40	mV
Load regulation ( $\Delta I_O = 1$ A $\rightarrow$ 10 A)	$\left(\frac{\Delta V_O}{\Delta I_O} \cdot \frac{10 \text{ A}}{5 \text{ V}}\right)$	0.4	%
Line regulation ( $\Delta V_i = 190$ V <sub>ac</sub> $\rightarrow$ 240 V <sub>ac</sub> )	$\left(\frac{\Delta V_O}{\Delta V_{ac}} \cdot \frac{220 \text{ V}_{ac}}{5 \text{ V}}\right)$	0.1	%
Dynatit overshoot during load change 10 A $\rightarrow$ 1 A	$\Delta V_O$	+150	mV
load change 1 A $\rightarrow$ 10 A	$\Delta V_O$	-150	mV
Regulating time	$t_{10\%}$	0.35	ms
Output current	$I_O$	0...10	A
Output short-circuit current	$I_{os}$	14	A
Efficiency ( $I_O = 10$ A)	$\eta$	80	%
Oscillator frequency	$f$	50	kHz

Table 4

### Components list

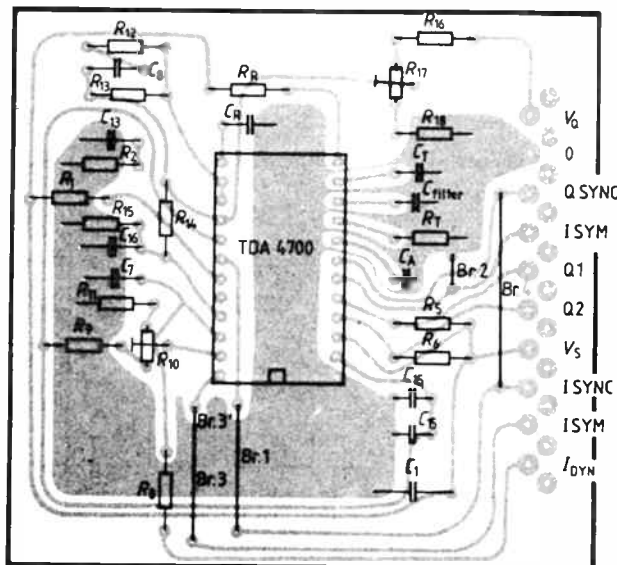
Quantity	Component	Ordering code
1	SMPS IC	TDA 4718 A
1	CMOS HEX inverter	4049 B
1	Operational amplifier	TAA 761 A
1	SiPMOS transistor	BUZ 80
1	Optocoupler	CNY 17-2
1	Bridge rectifier	B 250 C 700
1	Bridge rectifier	B 250 C 1000/700
1	Schottky dual diode	BYS 28
1	High-speed diode	BY 289/1000
1	Z diode	12 V/1 W
1	Z diode	3.0 V
1	Polypropylene capacitor	150 pF/630 V dc
2	STYROFLEX capacitors	820 pF/63 V dc
1	Ceramic capacitor	18 pF/100 V dc
1	MKT stacked-film capacitor	1 nF/400 V dc
1	MKT stacked-film capacitor	4.7 nF/400 V dc
1	MKT stacked-film capacitor	100 nF/100 V dc
1	MKT stacked-film capacitor	330 nF/100 V dc
2	X capacitors	1 $\mu$ F/250 V ac
1	Al electrolytic capacitor	4700 $\mu$ F/16 V dc
1	Al electrolytic capacitor	220 $\mu$ F/350 V dc
1	Al electrolytic capacitor	220 $\mu$ F/16 V dc
1	Tantalum electrolytic capacitor	22 $\mu$ F/16 V dc
1	Transformer ER 42	AZV 2125
<b>Choke:</b>		
1	Pot core	RM 10, N 41
1	Coil former	B65814-A1012-D1
2	Clamps	B65814-A2001-X
<b>Winding:</b>		
10 turns litz wire 4 $\times$ 30 $\times$ 0.1 mm CuL		
1	Heat sink for BUZ 80	$R_{thH} \leq 10$ K/W
1	Heat sink for BY 28	$R_{thH} \leq 6$ K/W
1	RFI suppression filter	B84110-A-A5

### 220 V ac - 5 V/20 A

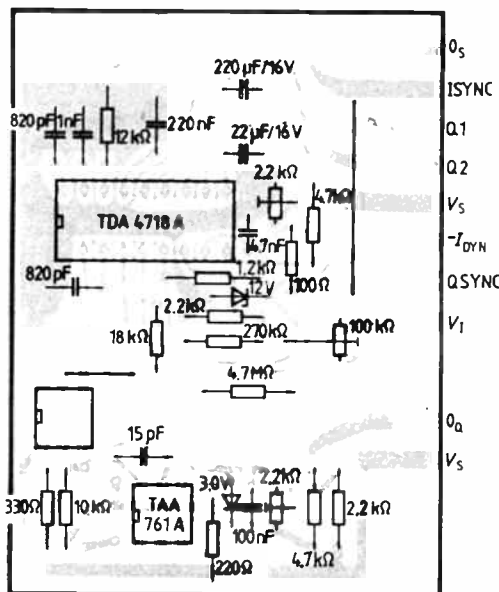
The following components must be used, in order to obtain an output current of 20 A with this SMPS:

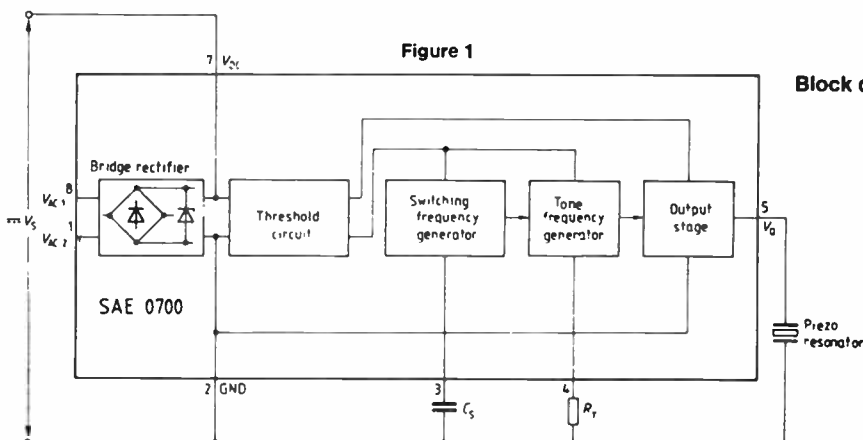
1	AC line rectifier	B 250 C 3000/1800	C67067-A1787-A3
1	Series resistor $R_s$	1.5 $\Omega$ /2 W	
1	Filter capacitor $C_1$	470 $\mu$ F/350 V dc	B43306-A4477-T
2	Output capacitors $C_2$	4700 $\mu$ F/16 V dc	B41336-A4476-T
1	Current measuring resistor $R_i$	0.33/0.3 W	
<b>Choke <math>L = 21.6</math> <math>\mu</math>H:</b>			
1	Cup core		B66443-A4000-X27
1	Cap		B66443-J-X27
1	Coil former		B66443-B1001-T9
<b>Winding:</b>			
Litz wire 12 turns 3 $\times$ 120 $\times$ 0.1 mm CuL			
1	Heat sink for BUZ 80	$R_{thH} \leq 6$ K/W	
1	Heat sink for BY 28	$R_{thH} \leq 3$ K/W	
1	RFI suppression filter		B84110-A-A10

SMPS control board with TDA 4700 - component layout



SMPS control board with TDA 4718 - component layout





Block diagram (with external components for dc supply)

### Pin configuration

Pin No.	Symbol	Function
1	$V_{AC2}$	AC-voltage input
2	GND	Ground
3	$C_S$	Connection for capacitor $C_S$
4	$R_T$	Connection for resistor $R_T$
5	Q	Output
6	N.C.	Not connected
7	$V_{DC}$	DC-voltage input
8	$V_{AC1}$	AC-voltage input

The audible signal device SAE 0700 generates two tone frequencies in a ratio of approx. 1.4 : 1 that follow one another in a periodic sequence. The tone frequency can be varied throughout a range between 100 Hz and 15 kHz by an external resistor. The switching frequency of 0.5 to 50 Hz is set by an external capacitor. The SAE 0700 can be used to drive either a loudspeaker or a piezo-ceramic transducer. The SAE 0700 can be supplied with voltage in two ways:

1. rms ac voltage from 10 V
2. dc voltage from 9 to 25 V

The SAE 0700 issues the tone sequence for as long as the supply voltage is applied. After application of the supply voltage, the tone sequence commences with the higher of the two tones.

### Features

- Direct ac-voltage feeding possible through integrated bridge rectifier
- Integrated overvoltage protection through Z diode, approx. 28 V
- Bridge rectifier provides for protection against incorrect polarity in dc operation
- Few external components (one resistor and one capacitor minimum)

### Maximum ratings

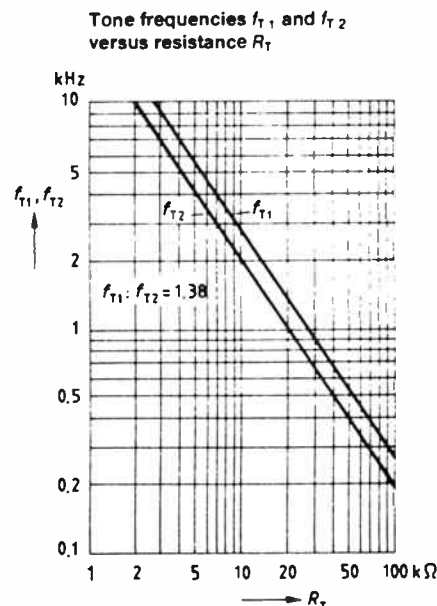
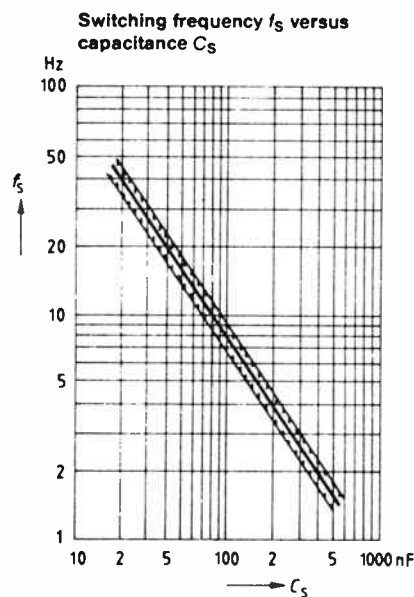
		Lower limit	Upper limit	
Voltage at pin 7	$V_{DC}$	-0.5	26	V
Voltage at pin 3	$V_{32}$	-0.5	5.5	V
Voltage at pin 4	$V_{42}$	-0.5	7	V
Output voltage at pin 5	$V_O$	-0.5	$V_{DC}+0.5$	V
AC voltage at pin 8 and 1 (peak value)	$V_{AC}$		28	V
Input current of bridge	$I_{B1}$	-50	50	mA
AC input current of bridge	$I_{B1 rms}$		25	mA

### Operating range

		Lower limit	Upper limit	
Supply voltage	$V_{DC}$	9	25	V
Tone frequency	$f_{T1}$	0.1	15	kHz
Ambient temperature	$T_{amb}$	-25	85	°C

### Characteristics

Characteristics		Test conditions	Lower limit B	typ	Upper limit A	
$T_{amb} = -25^\circ\text{C}$ to $85^\circ\text{C}$						
Current consumption	$I_{DC}$	$V_{DC} = 9\text{ V to }25\text{ V, w/o load}$		1.5	1.8	mA
Switching threshold	$V_{DC ON/OFF}$		8	8.6	9	V
Initial resistance	$R_{INI}$	see characteristic, figure 3	3.5	4.7	6	k $\Omega$
Output-voltage swing	$V_O$	$I_O = \pm 10\text{ mA}$	$V_{DC}-3.7$	$V_{DC}-3$		V
Tone frequency	$f_{T1}$	$V_{DC} = 15\text{ V, }V_{32} = 0\text{ V, }R_T = 16\text{ k}\Omega$	1.275	1.700	2.125	kHz
Switching frequency	$f_S$	$V_{DC} = 15\text{ V, }C_S = 100\text{ nF}$	5.6	7.5	9.4	Hz
Tone frequency ratio	$f_{T1}/f_{T2}$		1.31	1.38	1.45	
Temperature coefficient of tone frequencies	$TC_T$			$8 \times 10^{-4}$		K $^{-1}$



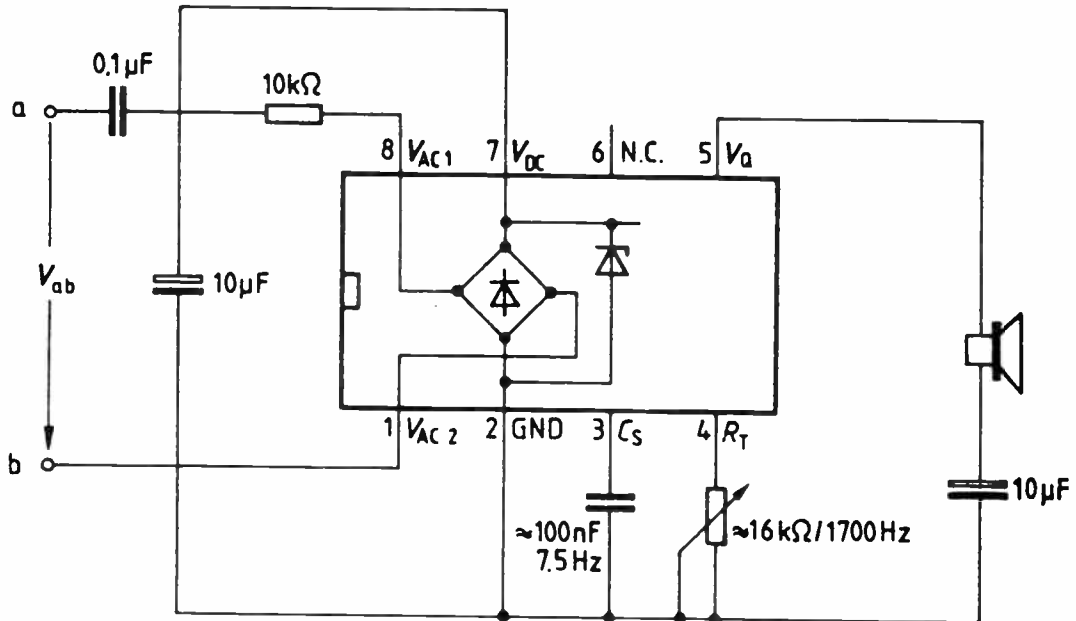


Figure 2

**Functional description**

The audible signal device SAE 0700 (see block diagram, fig. 1) includes the following functional blocks:

- bridge (for voltage supply) and overvoltage protection
- threshold circuit
- switching-frequency generator
- tone-frequency generator
- output stage

**Bridge rectifier:** The bridge rectifier enables direct feeding with ac voltage or dc voltage (independent of polarity). DC-voltage supply without integrated bridge is also possible via pins V<sub>DC</sub> and GND.

If the voltage is supplied via the bridge, the input voltage V<sub>AC1</sub> should be dimensioned such that at least 9 V appear at the pin V<sub>DC</sub> (also with output loading). It should also be noted that in the case of voltage supply via the bridge, the maximum output current has to be limited to 50 mA.

Response of the SAE 0700 as a result of spikes on the AC line is prevented by a built-in initial resistance R<sub>INH</sub>. In a voltageless condition R<sub>INH</sub> provides for discharging the storage capacitor of V<sub>DC</sub> to ground.

The Z diode following the bridge serves as overvoltage protection. The bridge circuitry shown in figure 2 efficiently protects the SAE 0700 against damage as a result of the following voltage values:

- overvoltages in acc. with VDE 0433 (2 kV - 10/700 µs)
- ac voltages up to 220 V/50 Hz for a duration of 30 s

**Threshold circuit:** With a threshold voltage of typically 8.6 V this ensures that the SAE 0700 is not activated by noise pulses.

**Switching-frequency generator:** This switches periodically between the two frequencies produced by the tone-frequency generator. Wiring with a capacitor C<sub>S</sub> produces a switching frequency f<sub>S</sub> according to the following formula:

$$f_s \text{ [Hz]} = \frac{750}{C \text{ [nF]}} \pm 25\% \quad (\text{valid from 0.5 to 50 Hz})$$

**Tone-frequency generator:** This generates a squarewave voltage with the two tone frequencies f<sub>T1</sub> and f<sub>T2</sub>. The basic frequency f<sub>T1</sub> and the second tone frequency f<sub>T2</sub> are calculated according to the following formulae:

$$f_{T1} \text{ [Hz]} = \frac{2.72 \times 10^4}{R \text{ [k}\Omega]} \pm 25\% \quad (\text{valid from 0.1 to 15 kHz})$$

$$f_{T2} \text{ [Hz]} = f_{T1} \times (0.725 \pm 5\%)$$

The tone-frequency generator is temperature-compensated for better stability.

**Output stage:** This boosts the generated tone voltage for direct driving of a piezo-ceramic transducer or a loudspeaker, possibly across a dropping resistor.



**SIEMENS ELECTRONIC COMPONENTS DISTRIBUTORS**

**NEW SOUTH WALES**

**PROMARK ELECTRONICS PTY LTD**  
Suite 208, Wentworth House,  
6-8 Clarke Street,  
Crows Nest, NSW 2065  
Phone: (02) 439 6477

**NEXUS ELECTRONICS PTY LTD**

399 Pacific Highway,  
Crows Nest, NSW 2065  
Phone: (02) 922 1722

**SOUTH AUSTRALIA**

**R.G. PANK PTY LTD**  
230 Franklin Street,  
Adelaide, SA. 5000  
Phone: (08) 51 2411

**PROTRONICS PTY LTD**

174-180 Wright Street,  
Adelaide, SA. 5000  
Phone: (08) 212 3111

**VICTORIA**

**PROMARK ELECTRONICS (VIC) PTY LTD**  
Suite 3, 366 Whitehorse Road,  
Nunawading, Vic 3131  
Phone: 878 1255 (03)878 1455

**QUEENSLAND**

**ECQ ELECTRONICS**  
16 Staple Street,  
Seventeen Mile Rocks, Qld 4073  
Phone: (07) 376 5677

**WESTERN AUSTRALIA**

**RESERVE ELECTRONICS**  
84 Edward Street,  
Perth, WA, 6000  
Phone: (09) 328 9755

**NEW ZEALAND**

**DELPHI INDUSTRIES LIMITED**  
27 Ben Lomond Crescent,  
Pakuranga, Auckland, New Zealand  
Phone: 56 7258 56 7891



## SUBSCRIBE NOW AND RECEIVE A SPECIAL FREE GIFT

When you subscribe to Australian Electronics Monthly, not only do you receive the brightest, most informative and most useful magazine around, but we'll give you a free gift of your choice!

Fill in the subscription form here, post it to us and we'll start your subscription from the next issue and send you your free gift.

### GIFT CHOICE 1

A pack of 23 selected 74LS ICs to the value of approx. \$27. This super pack contains the most common ICs, and are ideal for design, servicing, project construction, etc.



### GIFT CHOICE 2

A set of C. K. Allen Keys. Top West German quality. These little beauties are always in need and come in nine different sizes. They're ideal for anyone with an interest in electronics.

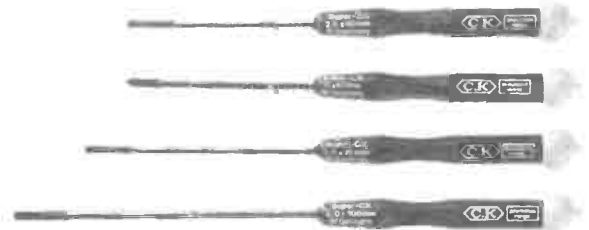


Not actual size

### GIFT CHOICE 3

Best quality West German screwdrivers from C.K.

We use these in our laboratory and consider them excellent as they are specifically designed for electronics requirements.



### GIFT CHOICE 4 \$10 Gift Voucher

If you elect to take our Subscribers' Gift Voucher, you can use it to get a \$10 discount when you purchase any item or items by mail order or in-store from any of your favourite electronics or computer retailers honouring the voucher when you make a purchase in excess of \$20. This offer is currently available from Jaycar, All Electronic Components, Applied Technology and Magraths.

Please forward me 12 issues of Australian Electronics Monthly and the gift  GIFT CHOICE 1  GIFT CHOICE 2  GIFT CHOICE 3  GIFT CHOICE 4

All cheques or money orders should be made payable to Australian Electronics Monthly.

Price for subscription is \$31.20 N.Z. \$A52.80 airmail

Please tick payment method  Cheque/money order  Bankcard  Visa  Mastercard  American Express

Card No. .... Expiration .....

Signature ..... (Note Unsigned credit card orders cannot be accepted)

Name .....

Address .....

..... Post Code .....

Allow a minimum of 4 weeks delivery of your gift

# A 'digital era' three-way, passive bass-reflex loudspeaker

David Tilbrook

Here's the second in our range of 'digital era' loudspeaker designs. Like the earlier two-way system, this design employs high-performance Vifa drivers with a bass-reflex port to extend the bottom end frequency range.

THE AEM6103 IS THE TOP OF THE RANGE of passive loudspeakers that we will be presenting in the 6100 series. It was originally intended that we might design a two-way, a three-way-loudspeaker. It became quickly obvious, however, that the superb quality of the Vifa drivers we had chosen to use would facilitate the design of a three-way loudspeaker with the performance characteristics that we had laid down for the four-way system! Furthermore, the three-way system offers certain advantages over the more complicated and expensive four-way system. To understand these advantages it is worthwhile looking at the function of the crossover in greater depth.

## Crossover considerations

The audio frequency spectrum extends from below 20 Hertz (Hertz = cycles per second) to beyond 20 kHz i.e. around 10 octaves. The reproduction of such a large bandwidth by electromechanical means is an extremely difficult task. At the low frequency end of the audio spectrum, wavelengths are metres long and drivers designed for this region must have large diameter cones which must be capable of very long excursions. At the high frequency end of the audio spectrum however, the wavelengths are around 15 mm and drivers designed for optimum performance at these frequencies have small, very light cones or domes so that they are capable of the extremely high accelerations and cone velocities required.

There are very few drivers with a frequency response which extends over the complete audio spectrum and the few that do achieve this do so by combining various acoustic phenomena in such a way that invariably leads to colouration of the sound and distortion. The only really viable solution is to combine several drivers, each designed for a specific region of the audio spectrum. A minimum multi-way system is the two-way, combining two drivers and an electrical circuit called the crossover to divide the audio spectrum into the two frequency regions. Similarly, a three-way system employs three drivers and a more complex crossover.

The perfect crossover would divide the audio spectrum into the relevant frequency bands by providing no impedance to signals with a frequency inside the passband and infinite impedance to all signals whose frequency lies outside the passband. This theoretically ideal crossover is, of course, never realised and the practicalities of crossover design pose considerable difficulties.

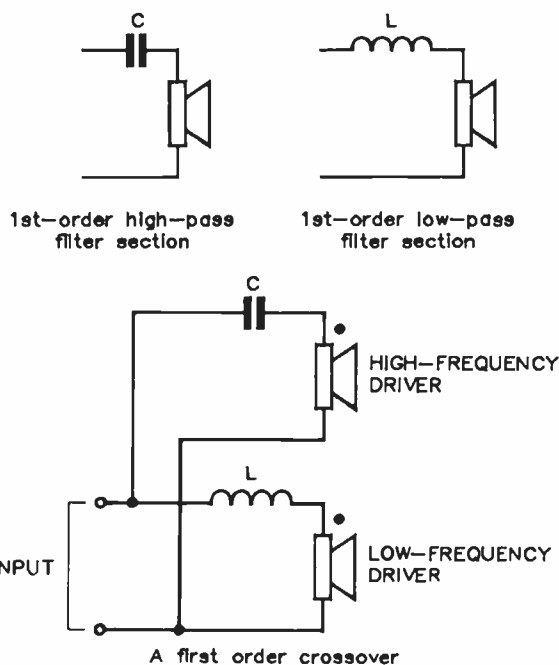


Figure 1.

The simplest form of crossover consists of just a single capacitor or inductor placed in series with the driver, as shown in Figure 1. This is called a *first-order filter* and gives a frequency response that decreases the amplitude of the input signal at a fairly slow rate outside of the passband (ultimate slope is 6 dB/octave). A crossover using first-order filters has the advantage that, at least theoretically, the outputs of the two filter sections will add together to give the original input signal.

The main disadvantage with first-order filters however, arises due to their relatively slow roll-off. In order to ensure that the outputs of the filter sections sum correctly it is necessary for the drivers to have a linear frequency response well beyond the proposed crossover point. If this is not the case, then the roll-off generated by the crossover and that due to the driver superimpose to produce a roll-off that is greater than the correct rate and this will not sum correctly with the output from the other filter section. The result is a frequency response characteristic with a dip around the crossover point.

Most drivers do not have a sufficiently extended frequency response for use with first-order crossovers. In order to achieve a faster rate of attenuation outside the passband another element is added to each of the filter sections. This produces a filter with an ultimate roll-off of 12 dB/octave and this is the most commonly used of all crossover designs.

Figure 2 shows the circuit diagrams for the second-order crossover. Note that, unlike the first-order crossover, the phase of the high-frequency driver in the second-order crossover is reversed with respect to that of the low-frequency

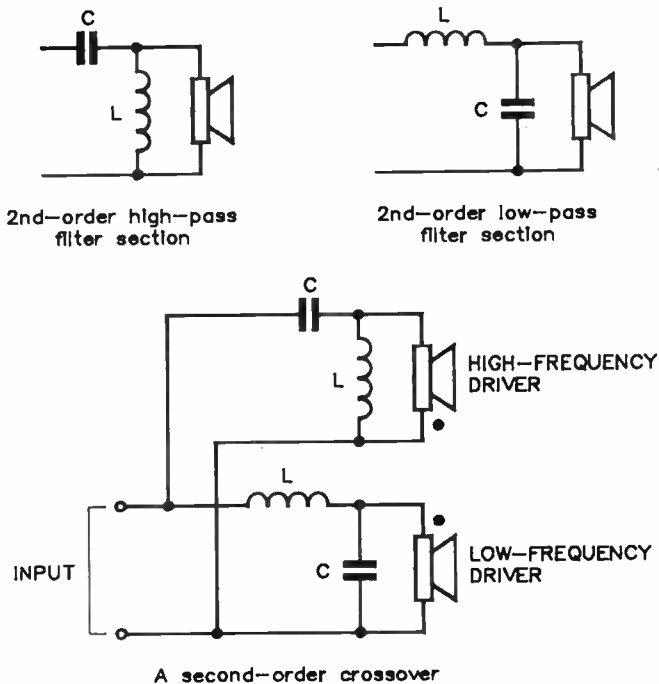


Figure 2.

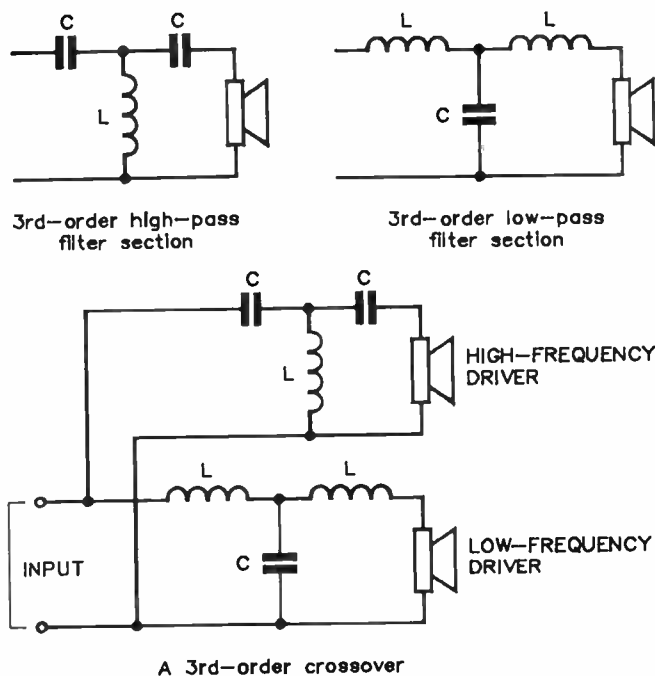


Figure 3.

driver. This is necessary since each of the second-order filter sections generates a phase characteristic which leads to an infinitely deep hole in the frequency response at the crossover point.

By inverting the wiring sense of one of the drivers the outputs of the two sections can be made to reinforce each other rather than cancelling. Unfortunately, this leads to a frequency response with a slight 'lump' of around 2 dB at the crossover point. For the vast majority of loudspeaker designs,



The prototypes were constructed of an attractive wood-veneered particle board. The protective grille cloth is simply stretched over a particle board frame fitted with plastic pins that clip into corresponding sockets recessed into the front baffle. Note that the grille covers the port too, but the frame should not obstruct the port.

however, this is not a real problem since the frequency responses of the drivers used exhibit amplitude non-linearities significantly greater than 2 dB.

In some designs where the frequency response non-linearity generated by the second-order filter is regarded as unsatisfactory, or the drivers are being used close to one or both of their useful ranges, the third-order filter is used. The design of these filters involves the addition of another set of elements and results in a frequency response characteristic with an ultimate roll-off of 18 dB/octave.

The third-order crossover is shown in Figure 3 and it is this type of crossover that is used for the AEM6103s. Notice that the two drivers are wired in phase this time. The third-order crossover yields a flat frequency response although it generates somewhat more phase error than does the second-order crossover.

All of these crossover schemes make the same implicit assumption that the outputs of the various drivers making up the loudspeaker will add to form a recombined signal that is as close as the crossover will allow to the original input signal.

# aem project 6103

Unfortunately, this is not the case since the various drivers must be mounted at different locations on the loudspeaker baffle. As the listening point differs in relation to the position of the drivers, the relative distance to the drivers also differs. If the distance of the listening position from each of the drivers is the same, then the outputs will add as required. If the listening position is changed, however, so that one of the drivers is closer than the others, then a frequency will exist for which the difference in distance will be one-half of a wavelength. At this frequency the outputs from the two drivers will interfere destructively, one cancelling the other, and a null appears in the frequency response (see Figure 4).

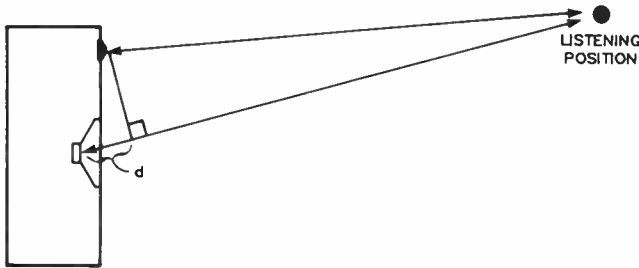


Figure 4. Difference in the distances of the drivers to the listening position will result in a dip in the frequency response at  $d = \frac{1}{2}$  wavelength.

The problem of destructive interference around the crossover points and crossover-generated phase errors will occur at every crossover point employed in the design. Unfortunately, this is simply one of the intrinsic disadvantages of multi-way passive loudspeakers and there are no easy solutions. One way to decrease the audible effects of these errors is to simply reduce the number of crossover points. This is one advantage of a three-way system over a four-way system. Provided that an equally good frequency response is achievable with a three-way system as with the four-way, then the three-way system with fewer crossover points will exhibit fewer phase related problems.

## Driver considerations

The basis of any three-way loudspeaker is the proposed mid-range driver. A good mid-range driver is one with an extended frequency response, covering the range from below 500 Hz to beyond 3 kHz. At the top end of this frequency range cone-type drivers tend to suffer somewhat from a restricted spatial distribution of the high frequency sound waves. This problem of "beaming" at high frequencies is best overcome by the use of dome-type mid-range rather than a more conventional cone-type. Other attributes that are essential for a good quality mid-range are good transient performance, power handling ability and low distortion.

Finding a mid-range driver with all these attributes is not easy but, fortunately, Vifa manufacture just such a device. The D75MX is a 75 mm diameter dome mid-range with a frequency response that extends from below 400 Hz to beyond 4 kHz with a power handling of 80 W (DIN 45573). The transient performance is exceptional and one of the first things I noticed when the driver was auditioned.

In the AEM6103s I have combined this driver with a third-order crossover points at 500 Hz and 4.3 kHz. The resulting mid-range frequency response is shown in Figure 5.

This mid-range requires the use of a small separate enclosure of around 1.5 litres capacity. In this design, a small enclosure is fabricated from chip-board and mounted from the front baffle immediately behind the dome mid-range and tweeter.

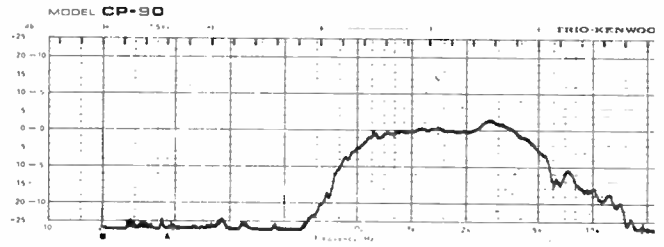


Figure 5. Frequency response of the mid-range driver and mid-range crossover section.

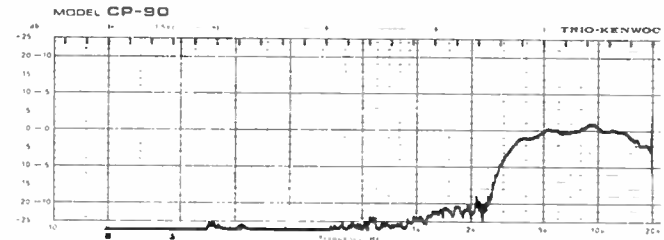


Figure 6. Frequency response of the high frequency driver and high frequency crossover section.

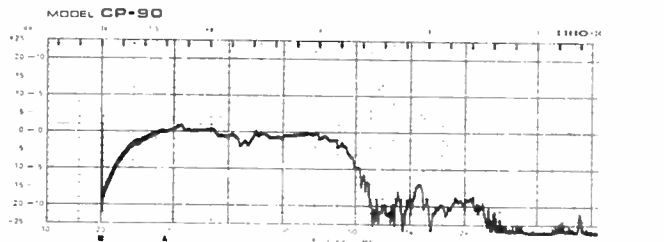


Figure 7. Frequency response of the bass driver and low frequency crossover section.

The high-frequency driver chosen was the D19TD-05 which is a 19 mm dome tweeter with magnetic fluid cooling. The device is capable of remarkable power handling (around 80W, DIN 45573) when used with the third-order crossover specified here.

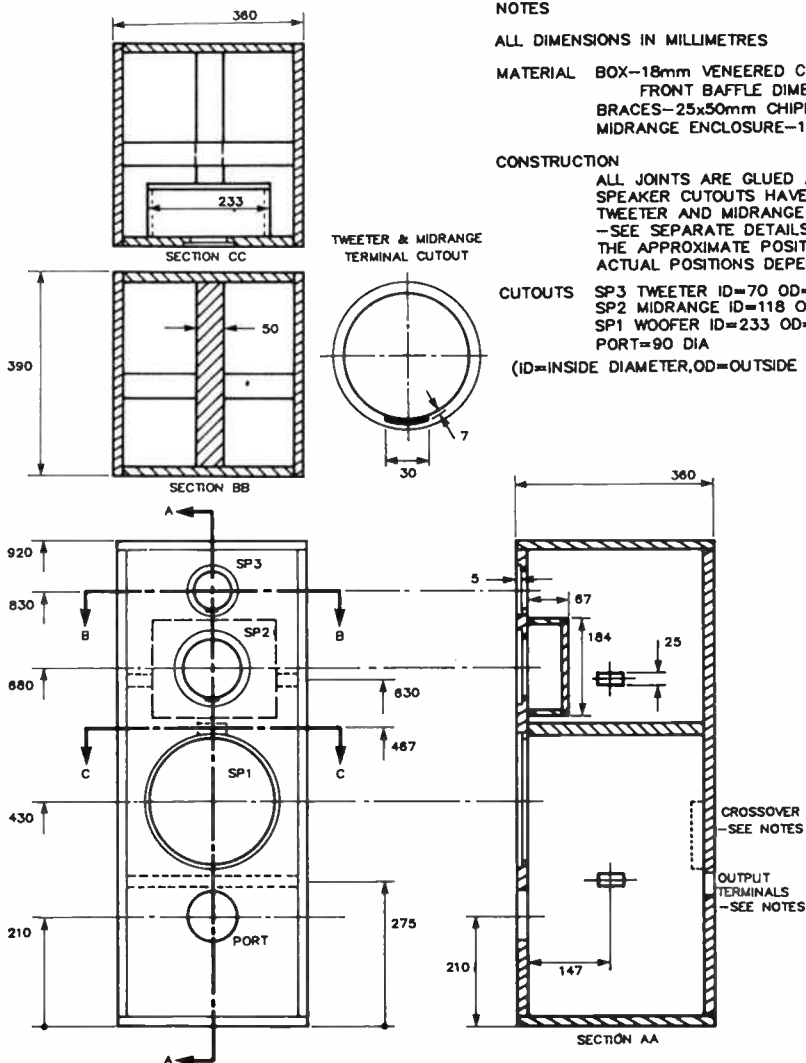
The choice of bass driver and cabinet design was done after carrying out fairly extensive computer modelling to enable the best possible matching of driver, cabinet size and port dimensions. The final choice was to use the P25WO bass driver in a bass-reflex cabinet with an internal volume of 100 litres. This was found to be the optimum box volume for this bass driver. A smaller box would severely restrict the bass end performance while a larger box would impair the frequency response linearity of the design at low frequencies.

The result is a bass end performance that I believe will rival the best loudspeakers, irrespective of price. As shown in Figure 7, the frequency response is only 3 dB down at 30 Hz and the loudspeaker provides useful output well below this

## CARE OF THE DRIVERS

The drivers used in this project are expensive and delicate. Take great care when handling them. When soldering to the terminals be careful not to overheat the terminal strip unnecessarily. Do not apply pressure to the terminal strips or these can be displaced from their mounting positions and snap the fine wires connecting these to the voice coils.

The domes of the tweeter and mid-range units are particularly delicate. Be careful not to allow these to be pushed in or damage to the drivers could be irreparable.



**NOTES**

ALL DIMENSIONS IN MILLIMETRES

**MATERIAL** BOX—18mm VENEERED CHIPBOARD, OUTSIDE DIMENSIONS 920x360x390

FRONT Baffle DIMENSIONS 884x324x18

BRACES—25x50mm CHIPBOARD, 3 PIECES 2x324, 1x354

MIDRANGE ENCLOSURE—10mm CHIPBOARD, OUTSIDE DIMENSIONS 233x184x67

**CONSTRUCTION**

ALL JOINTS ARE GLUED AND SCREWED

SPEAKER CUTOUTS HAVE A 5mm DEEP ROUTING FOR FLUSH MOUNTING OF THE SPEAKERS

TWEETER AND MIDRANGE CUTOUTS HAVE AN EXTRA SLOT FOR THE TERMINALS

—SEE SEPARATE DETAILS

THE APPROXIMATE POSITIONS OF THE CROSSOVER AND OUTPUT TERMINALS ARE SHOWN, ACTUAL POSITIONS DEPEND ON THE TYPE OF EACH USED

**CUTOUTS**

SP3 TWEETER ID=70 OD=96

SP2 MIDRANGE ID=118 OD=154

SP1 WOOFER ID=233 OD=263

PORT=90 DIA

(ID=INSIDE DIAMETER, OD=OUTSIDE DIAMETER)



figure. The transient performance of the bass end is also excellent and it was this aspect of the overall performance of the loudspeaker which drew most of the comment during the subjective testing phase of the development.

Data sheets for the three Vifa drivers are included elsewhere in this issue.

**Construction**

The prototype loudspeaker enclosure was constructed using 19 mm veneered particle board to which additional bracing was fitted to minimise the effects of vibration which is likely at higher output powers. The internal bracing was accomplished using pieces of particle board glued from side to side, and from front to back as shown in the construction drawings accompanying this article. All of the drivers are externally mounted so the box need not have a removable back or front.

The bass reflex port is a length of PVC irrigation pipe which is glued into position on the front baffle. The length of this port is critical and should be cut as accurately as possible (within +/- 1 mm).

If you are constructing the boxes yourself, it is very important to ensure that all of the joints are sealed well. The pressure inside even a ported enclosure is substantial and leaks generally give rise to whistles or hissing sounds that will impair the performance of the loudspeaker at high volumes. The best solution is to line all of the joints on the

inside of the box with a silicone sealant, available from most hardware stores (e.g. Selley's 'Silastic').

The mid-range enclosure should be built before mounting the front baffle in place and installed within the cabinet. It can then be sealed to the front baffle once this is mounted in place. The speaker input terminals mount on the rear baffle, low down. They should be of a type designed to maintain a good seal.

The entire mid-range enclosure should be filled with medium density mattress overlay foam (I obtained some from a Clark Rubber store). I found it easier to work with the 25 mm thick material for the mid-range enclosure and the 50 mm material for the lining of the main bass chamber.

Before lining the enclosures, however, it is necessary to construct the crossover and solder the wires to it that will lead to the drivers. The crossover for this project is being manufactured by Nelson Components, (66 Blackbutt Ave, Lugarno (02) 53 9684) and will be available in full assembled form through a variety of retail outlets. **to p. 100 ▶**

**LEVEL**

We expect that hobbyists who are

**BEGINNERS**

in electronics construction should be able to successfully complete this project.

# Circuit-Board-Design Without the Tedium

smARTWORK™ lets the design engineer create and revise printed-circuit-board artwork on the IBM Personal Computer.

Forget tape. Forget ruling. Forget waiting for a technician, draftsman, or the CAD department to get to your project. smARTWORK™ software turns your IBM Personal Computer into a professional, high-quality drafting tool. It gives you complete control over your circuit-board artwork—from start to finish.

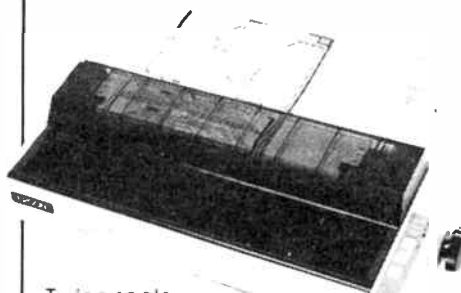


smARTWORK™ transforms your IBM PC into a CAD system for printed-circuit-board artwork. Display modes include both single-layer black and white and dual-layer color.

What makes smARTWORK™ so smart is that it understands electrical connections. Conductor spacing is always correct, lines don't become too narrow, and connecting lines do not intersect other conductors. smARTWORK™ can automatically find and draw the shortest route between two conductors. Or you can specify the route.

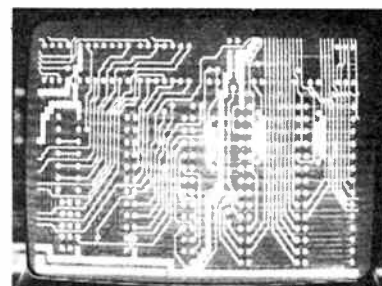
smARTWORK™ is the only low-cost printed-circuit-board artwork editor with all these important advantages:

- Complete interactive control over placement and routing
- Quick correction and revision
- Production-quality 2X artwork from pen-and-ink plotter
- Prototype-quality 2X artwork from dot-matrix printer
- Easy to learn and operate, yet capable of sophisticated layouts
- Single-sided and double-sided printed-circuit boards up to 10 x 16 inches
  - Multicolor or black-and-white display
  - 32 user selectable color combinations; coincident points can be displayed in contrasting colors.
  - Can use optional Micro-soft Mouse as pointing device.



Twice scale hardcopy of your artwork is produced using the Epson dot-matrix printers or the Houston instrument DMP-42 pen-and-ink plotter. Quick 1X check plot is also available from Epson printers.

™smARTWORK™ and "Wintek" are trademarks of Wintek Corporation.



Dual-layer color display of a 2" by 4" section of a 10" by 16" circuit board

## The Smart Buy

smARTWORK™ is exceptional value, particularly when compared to conventional engineering workstation costs.

Call or write to us for more information on smARTWORK™. We'll be glad to tell you how smARTWORK™ helps us design our own circuit boards and what it can do for your business.

## System Requirements

- IBM PC, XT or close compatible with 192K RAM, 2 disk drives and DOS Version 2.0 or later.
- IBM Color/Graphics Adaptor with RGB color or B&W monitor.
- Epson MX80/MX100 or FX80/FX100 dot matrix printer or compatible with Grafrax.
- Houston Instrument DMP-42 pen-and-ink plotter (preferred). Small Houstons and HP7475A also supported.
- Microsoft Mouse (Optional).



Australian Distributors: **Microtrix Pty. Ltd. 24 Bridge Street, Eltham, Victoria. (03) 439 5155**

## Commodore's Amiga to appear March-April

Commodore's Amiga, much-heralded in the overseas press, will make its appearance in the stores here around March-April. Commodore says it's delaying the release until sufficient programs are available for it.

The Amiga combines the text & numeric-oriented approach of the 'IBM-line' PCs with the graphics & sound approach of the 'Macintosh-line' PCs.

Commodore claim that, before the Amiga, users were stuck with one approach or the other in making a choice on which hardware to buy. Now they can happily combine both in the one machine to produce "... more powerful, imaginative, colourful and multi-dimensional work".

The Amiga features a Motorola 68000 processor running at just over 7 MHz, 256K dynamic RAM (user-expandable to half a meg) and 192K of ROM containing multitasking, graphics, sound and animation support routines.

Five graphics modes are provided: two 32-colour modes of 320 x 200 and 320 x 400 pixels, two 16-colour modes of 640 x 200 and 640 x 400, plus a sample-and-hold mode. You get independent horizontal and vertical scrolling of dual 'playfields', eight hardware sprites and a palette of 4096 colours. Apparently, the sound capabilities have to be heard to be believed, Commodore describing them as "compact disc-like".

As you'd expect, it comes with a two-button mouse. Optional peripherals include a 3½ inch

880K-byte disc drive, RGB analogue colour monitor, 256K-byte memory expansion module, 300/1200-bps modem, a MIDI interface and a video frame grabber.

As a multi-tasking system, the Amiga is capable of working on several chores simultaneously. It can display multiple windows, each with its own task, as well as simultaneously displaying multiple screens with different graphics resolution modes. And moving from one screen to another can be achieved at the touch of a single button.

Another new feature is the system's bundled text-to-speech capability with an unlimited vocabulary using plain English typed in to the machine. You can call on a range of pitches for both male and female voices, and even place expression on selected words.

Integration of video images with computer sound and graphics is another feature that makes Commodore's Amiga the most advanced personal computer available for applications at both professional and consumer levels, says Commodore.

It is expected to find a big demand in architecture, movies and television production, computer-aided design and construction,



type-setting, technical documentation and video animation.

### Better backups

When we first received Daneva's information about flexible streaming backup, we thought that the cure for the common cold had been found at last. However, Wangtek (which Daneva represents) claim to have solved the driver interchangeability problem which has plagued the cartridge backup system for years.

By using a combination of precision drive mechanism and burst track on the tape, the Wangtek drive will position its head relative to this "home track", thus allowing tape cartridges to be read in any other Wangtek drive.

PC-DOS 2.0, 2.10, and 3.0 will support the drive controller which plugs into the PC or PC/XT expansion slot. Designated model PC-36, the package comes complete with cables, menu-driven disk-based software, and drive unit.

Now there is no excuse for not performing regular backups. Information is available from Daneva Australia Pty Ltd in Victoria on (03) 598 5622, or the newly-opened Sydney office at 47 Falcon Street, Crows Nest 2065 (02) 957 2464.

### Philips PC Displays Videotex Graphics

Philips Communications Systems are including Videotex software at no extra charge with every Philips P3100 personal computer it sells.

To access Telecom's Viatel videotex service, a Philips personal computer user will only need to register as a Viatel user and buy a suitable modem to connect the P3100 to the telephone system.

The P3100 is compatible with the industry standard for personal computers but has significant enhancements over competing models. Philips claim, with built-in graphics capability whereas with other personal computers this is an optional extra.

Significantly, this means that the P3100 can display both text and graphics videotex data on its standard monochrome screen, without the addition of a graphics board.

Philips' videotex software package also works with the P3100's optional colour monitor and a colour graphics board.

For users of other industry-standard personal computers, Philips are selling the videotex software for \$175.

#### NEW PROGRAMMERS CLUB IN MELBOURNE

We have been asked by the Personal Programmers of Melbourne (PPM Club) to advertise their existence in our "excellent publication" (flattery will get you everywhere).

Although PPM is a new club, many of the members come from a previous club devoted to Hewlett Packard handheld calculators.

The new club has broadened its range to include all handheld computers or calculators. They meet on the third Tuesday of every month at 8pm on the 9th floor of the Menzies Building, Monash University. The club also sends out a monthly newsletter of interesting and helpful news, which includes a summary of the talk given by the guest speaker at the previous meeting.

Details from Paul Cooper, Subscription Manager, 40 Karen Street, Box Hill North, 3129 Vic. (03) 898 7672.

# Using the Listening Post with your Apple

Neil Duncan VK3AVK

Now it works on the Apple 11, too! Snoop through the airwaves with the multimode, all bells and whistles Listening Post with yet another computer.

THIS VERSION of the Listening Post Software has some rather 'different' design parameters — ones I suspect will meet the needs of others who, like myself, wish to try computerised radio without much cost. The features aimed for at the design stage were:-

- A printer should not be essential
- The Apple 'games port' is used (no expensive card needed)
- FAX pictures to be built on-screen before your very eyes!
- Inversion of FAX pictures available
- Inversion of RTTY code possible
- CW and RTTY 'tuner-upper' mode built in
- Main programming in machine code
- Supervision of code from BASIC

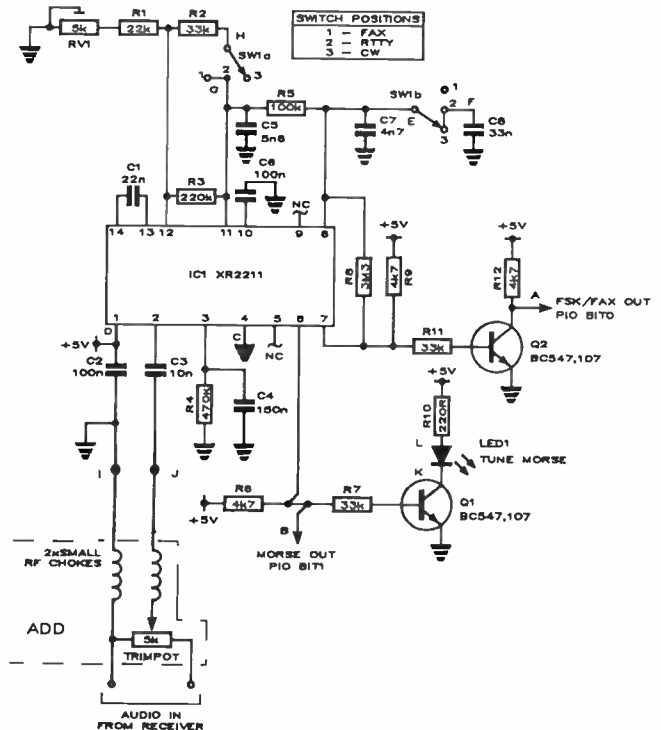
## Hardware Requirements

Here is the shopping list. First, one 'Listening Post' kit of parts. I purchased a kit. If you are intending to buy parts separately, you could achieve a significant improvement by buying a die-cast (i.e: metal) box for the thing. It should reduce RFI (RF interference generated by the computer getting into the radio by a worthwhile amount compared with the plastic box otherwise supplied).

Next, you need one metre of three (or more) core cable. It must be shielded, for RFI reasons, again. I found some five-core stuff with a very solid outer layer of metal which does the trick. Cable with separate shielding would be fine, but be prepared for some pretty tricky soldering at one stage if you choose to use it. You need one 16-pin 'DIP header' — you know, a plug looking like an IC with no brain and that you can solder onto. These plugs come in various grades. Go for the best one you can find. Note that if your shielded cable is as solid as mine, you will probably be unable to use the little hat supplied with some styles of plugs.

You'll need two RF chokes. I found a significant RFI reduction was achieved by putting them in series with the audio lines into the project. As a measure of economy (perhaps your computer is well and truly removed from the radio set) you may wish to start off without these and see how things go.

Also, add one 5k trimpot. The level coming from my receiver was too high and this helped considerably in beating the problem of noise-spiked triggering of the program. The input circuit now looks like this —



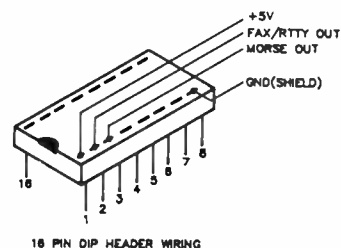
Modified input circuit for the Listening Post. The RF chokes may be any value less than 1 mH. The trimpot allows input level adjustment.

Finally, you will need one length of cable for connecting the Listening Post to the receiver, terminated in suitable connectors. Shielded, of course.

## Constructing the decoder

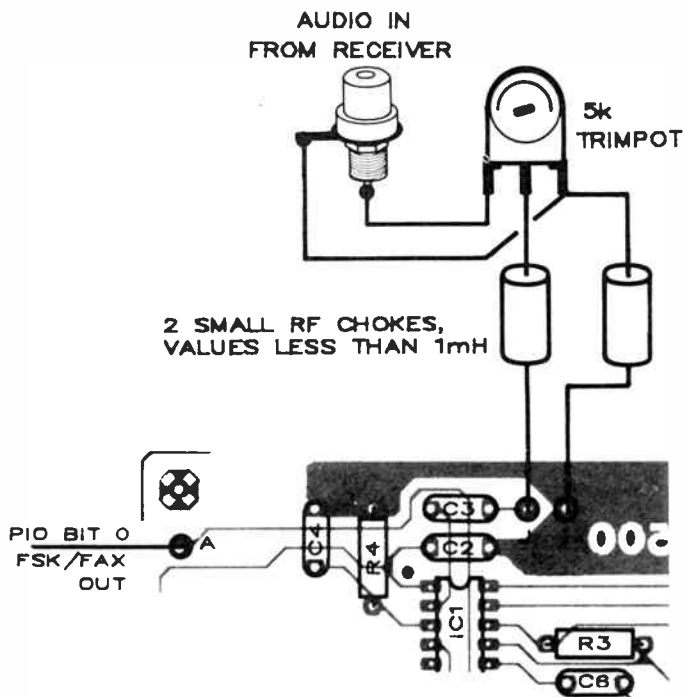
Carefully sort out the connections from the Apple to the decoder, particularly the +5 volt line. Take care with the LED polarity and the wiring of the audio input plug. That aside, it would spoil your whole day to have baked Apple rather than weather pictures — the connecting-up stage is quite critical.

Once the project is finished, connect it to the 16-pin plug according to this diagram:-



Here's how you wire-up the 16-pin DIP header for connecting the Listening Post to the Apple //.

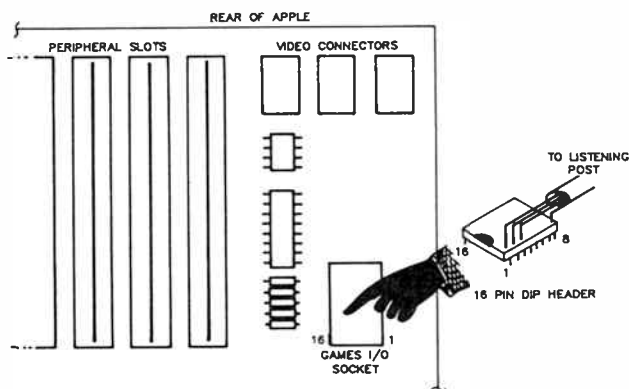




Here's how you connect up the extra components to the Listening Post's input.

Another possibility — it is becoming popular to include a word-processor modification to Apple computers called the 'keyboard strap'. This takes some thinking about if you are to have it at the same time as the 'Listening Post' plug. It can be done without much fuss (I use it). A similar crisis will arise if you have a joystick connected to the input. That is more difficult and may require a change in lifestyle. Playing games via the games port? Tsk,tsk.

It is most important to observe how the new plug is orientated with respect to the Apple board:-



Here's where you plug the Listening Post into the Apple II.

The first item on that list caused the largest number of headaches. To me, anyway, the compulsory need for a printer seemed the greatest drawback to the Moffat design (gedday Tom!) for the Microbee. There are lots of computer owners who do not have a dot matrix printer. I guess they would see the need for one if the package uses it as the central concept. Not here folks! The Apple graphics scheme allows easy point-by-point plotting and that is how the picture is constructed with this software.

From the outset, the decision to draw the FAX picture on-screen dictated the overall shape of the project. If the picture is built in memory and then dumped to a printer then so much memory is used that many of the other features mentioned above would not have been as easily accommodated.

In addition, it is really interesting to sit back and watch a weather map being built up on the screen. I must say that I haven't found a use for an on-the-spot weather map yet, but that is all part of the charm of it all. None of my neighbours have freshly squeezed weather maps first thing in the morning! I must mention though, that printing out the map (perhaps you do have a printer, eh?) is a very simple option if you want it. Screen dumps are particularly straightforward. Just look up the particular command sequence from BASIC to dump hi-res page 1 and put it into the program. The package here has a typical command built-in already.

That completes the good news. Now for some bad. Having committed hours to the wretched FAX program, and having delighted in the beautiful on-screen goodies that are produced, the matter of picture resolution became a rather depressing feature. The ideal thing would have been to have a computer screen with 400 or so dots across and similar numbers down. Such is not the case with the Apple screen (and not, for that matter, many other computers).

We have a screen 280 dots wide and 192 down and I have used just about all of the dots for the picture. That is the limiting factor of the whole thing. The problem, is when they send writing in their pictures. It just is too smudgy to read. Ah well, a small price to pay when a no-mystery, real-time display is available. It really beats waiting nine minutes or so (with a blank screen) before for the printer does its thing. The pikkie builds up in front of your eyes. Lots of little pixels marching into a pattern.

If, however, there is a veritable surge of people gnashing teeth and shaking fists over this little matter, then perhaps a second on-screen, printer based version could be arranged. It is pretty difficult to have both, by the way. On-screen build-up and very hi-res printer pictures; you can't get the memory, you know.

The other little negative feature is within the CW (Morse) section. I found a very tempting corner to cut at one stage. The 6502 only has 8-bit registers and as a consequence, counters can only count as far as 255. With quite a bit more work, I could have programmed the automatic speed tracking feature to cope with all speeds. What I did, however, was to split the speed range in two. From 4-25 words per minute (wpm) and 25-100 wpm. You must select one of those speed ranges otherwise the dots and dashes cause the computer to throw up a bit. Personally, I don't find this two-range requirement a problem — I hope you don't! Blame those 8-bit counters (and the fact that I can't resist life's little temptations!) if you do.

The way in which I wired the two new RF chokes and the trimpot to the audio input plug does not warrant a special diagram here. Suffice to say that the pristine neatness of the kit degenerates at this stage.

## Software: where do you get it?

There are two main ways of approaching the acquisition of the software for this project. You may purchase a copy (obviously the least difficult method). You won't even need a bank loan. You also won't really need to read the next few paragraphs unless, of course, you want to modify the program at some stage. For the genuine hacker/home brewer, here are the series of steps you will need to go through in order to get the system up and running.

### Stage 1.

Load DOS into the computer from a standard disk (i.e: switch on and put a disk in). When things settle down a bit, put a blank (or spare) disk in and enter the following code:-

Type NEW then

```
10 REM BOOT PROGRAM
30 PRINT CHR$ (13); CHR$ (4); "LOAD MORFART"
40 PRINT CHR$ (13); CHR$ (4); "RUN MAINLINE"
```

Now type INIT HELLO. This will become the 'boot program'. ▶

## Stage 2.

Type NEW and then the following little program. Watch the usual traps of O's and zeros and of I's and ones. Tell yourself it will all be worth it in the end!

```
10 TEXT : HOME : VTAB (23) : PRINT "FAX/RTTY/CW DECODER BY NEIL DUNCAN":
20 VTAB (10) : HTAB (15) : PRINT "PRESS ANY KEY": GOSUB 9000
30 FOR I = 1 TO 11: READ N,D: POKE LNTHZ,I: POKE FRQZ,N: POKE
   TIMEZ,D: CALL PLAYZ: NEXT I
50 RESTORE: FOR I = 1 TO 100: IF PEEK (- 16384) > 127 THEN I = 1000
55 NEXT I: IF I < 1000 THEN 10
60 POKE - 16384,0: HOME : HTAB (15) : INVERSE : PRINT "MAIN MENU": NORMAL
70 VTAB (8) : HTAB (10) : INVERSE : PRINT "1": NORMAL : PRINT " FAX"
80 VTAB (10) : HTAB (10) : INVERSE : PRINT "2": NORMAL : PRINT " RTTY"
90 VTAB (12) : HTAB (10) : INVERSE : PRINT "3": NORMAL : PRINT " CW"
100 VTAB (14) : HTAB (10) : INVERSE : PRINT "4": NORMAL : PRINT " END"
110 VTAB (19) : HTAB (20) : PRINT "SELECT": GET AS: IF AS < "1" OR AS >
   "4" THEN PRINT "control-G": GOTO 60
120 IF AS < "4" THEN 180
130 HOME : VTAB (10) : PRINT "TO END, PRESS E OTHERWISE PRESS ANY KEY"
140 PRINT TAB (15); "-"
150 VTAB (19) : HTAB (20) : PRINT "SELECT": GET AS: IF AS < "E" THEN 10
160 AS = "4"
180 ON VAL (AS) GOSUB 1000,2000,3000,20000
190 GOTO 60
```

```
1000 REM FAX RTN
1005 GOTO 1045
1010 HOME
1020 HCOLOR= 0: POKE 230,32: HPL0T 0,0: CALL 62454
1030 TEXT : HOME : VTAB (10) : HTAB (10) : PRINT "TO START, PRESS A KEY":
   GET AS
1040 POKE 49239,0: POKE 49236,0: POKE 49232,0: POKE 49234,0: CALL FAX
1045 TEXT : HOME : PRINT "NOW SELECT..."
1050 VTAB (8) : HTAB (10) : INVERSE : PRINT "1": NORMAL : PRINT
   " RECEIVE PICTURE"
1060 VTAB (10) : HTAB (10) : INVERSE : PRINT "2": NORMAL : PRINT
   " VIEW PICTURE AGAIN"
1070 VTAB (12) : HTAB (10) : INVERSE : PRINT "3": NORMAL : PRINT
   " INVERT PICTURE"
1080 VTAB (14) : HTAB (10) : INVERSE : PRINT "4": NORMAL : PRINT
   " PRINT PICTURE"
1085 VTAB (16) : HTAB (10) : INVERSE : PRINT "5": NORMAL : PRINT
   " MAIN MENU"
1090 VTAB (19) : HTAB (20) : PRINT "SELECT": GET AS: IF AS < "1"
   OR AS > "5" THEN PRINT "control-G": GOTO 1045
1100 ON VAL (AS) GOTO 1010,1300,1400,1200,1999
1200 REM PRINTER COMMANDS
1210 PR# 1
```

```
1220 PRINT CHR$ (145)

1230 PR# 0
1280 REM PRINTER COMMANDS
1290 GOTO 1045
1300 REM VIEW SCREEN
1310 POKE 49239,0: POKE 49236,0: POKE 49232,0: POKE 49234,0: GET AS
1320 GOTO 1045
1400 REM INVERT
1410 CALL NGTIVE
1420 GOTO 1300
1999 RETURN
```

```
2000 REM RTTY
2010 TEXT : HOME : PRINT "NOW SELECT..."
2020 VTAB (8) : HTAB (10) : INVERSE : PRINT "1": NORMAL : PRINT
   " RECEIVE RTTY"
2030 VTAB (10) : HTAB (10) : INVERSE : PRINT "2": NORMAL : PRINT
   " TUNE UP"
2040 VTAB (12) : HTAB (10) : INVERSE : PRINT "3": NORMAL : PRINT
   " INVERT"
2050 VTAB (14) : HTAB (10) : INVERSE : PRINT "4": NORMAL : PRINT
   " CARRIER/NON CARRIER"
2060 VTAB (16) : HTAB (10) : INVERSE : PRINT "5": NORMAL : PRINT
   " MAIN MENU"
2070 VTAB (19) : HTAB (20) : PRINT "SELECT": GET AS: IF AS < "1"
   OR AS > "5" THEN PRINT "control-G": GOTO 2000
2080 ON VAL (AS) GOTO 2100,2200,2300,2400,2900
2100 HOME : VTAB (23) : HTAB (5) : PRINT
   "ESC 123456789 B OR A OR L OR F": POKE 35,22: VTAB (1) : HTAB (1)
   CALL RTTY
2110 CALL RTTY
2120 POKE 35,22: GOTO 2000
2200 CALL RYTUNE
2210 GOTO 2000
2300 REM INVERT
2310 HOME : X = PEEK (17345):A = 0: IF X = 0 THEN A = 1
2320 POKE 17345,A:AS = "NORMAL": IF A = 1 THEN AS = "INVERTED"
2330 VTAB (15) : HTAB (10) : PRINT "SENSE NOW ":AS: VTAB (21) : PRINT
   "PRESS ANY KEY": GET AS: GOTO 2000
2400 REM CARRIER REQUIRED?
2410 HOME : X = PEEK (17082):A = 234:B = 234:C = 234: IF X = 234 THEN
   A = 76:B = 78:C = 66
2420 POKE 17082,A: POKE 17083,B: POKE 17084,C:AS = "REQUIRED":
   IF A = 234 THEN AS = "NOT REQUIRED"
2430 VTAB (15) : HTAB (10) : PRINT "CARRIER NOW ":AS: VTAB (21) :
   PRINT "PRESS ANY KEY": GET AS: GOTO 2000
2490 GOTO 2000
2900 RETURN
```

```
3000 REM CW DECODE
3005 POKE 35,24
3010 TEXT : HOME : PRINT "CW ROUTINE, TO EXIT AT ANY ": PRINT
   : PRINT "STAGE, PRESS ANY KEY."
3020 VTAB (10) : HTAB (10) : INVERSE : PRINT "(1)": NORMAL : PRINT
   " TUNE UP"
3030 VTAB (12) : HTAB (10) : INVERSE : PRINT "(2)": NORMAL : PRINT
   " RUN DECODER"
3040 VTAB (14) : HTAB (10) : INVERSE : PRINT "(3)": NORMAL : PRINT
   " SPEED"
3050 VTAB (16) : HTAB (10) : INVERSE : PRINT "(4)": NORMAL : PRINT
   " MAIN MENU"
3055 VTAB (20) : HTAB (18) : PRINT "SELECT": GET AS
```

```
3060 IF AS < "1" OR AS > "4" THEN PRINT "control-G": GOTO 3000
3070 IF AS = "4" THEN RETURN
3080 IF AS = "1" THEN CALL TUNE: GOSUB 3200: GOTO 3000
3090 IF AS = "2" THEN GOSUB 3200: CALL CW: GOTO 3000
3100 HOME : X = PEEK (17683):A = 5: IF X = 5 THEN A = 37
3110 POKE 17683,A:AS = "HIGH": IF A = 37 THEN AS = "LOW"
3120 VTAB (15) : HTAB (10) : PRINT "SPEED NOW ":AS: VTAB (21) : PRINT
   "PRESS ANY KEY": GET AS: GOTO 3000
3200 HOME : VTAB (24) : HTAB (10) : PRINT "TO EXIT, PRESS ANY KEY"
   : VTAB (1) : HTAB (1) : POKE 35,22: RETURN
```

```
9000 REM DATA SETUP
9010 FAX = : /68:RTTY = 16954:CW = 17347:NGTIVE = 16790:TUNE = 16825
   :RYTUN: = 16861
9020 LNTHZ = 16950:FRQZ = 16947:TIMEZ = 16948:PLAYZ = 16897
9100 DATA 100,40,0,2 ,93,40,0,2,81,40,0,1,74,66 ,0,60,100,40,
   0,10,74,254
9110 RETURN

20000 REM THATS IT!
20010 RESTORE
20020 FOR I = 1 TO 11: READ N,D: POKE LNTHZ,I: POKE FRQZ,N:
   POKE TIMEZ,D: CALL PLAYZ: NEXT I
20030 HOME : END
```

Then type SAVE MAINLINE. This is the program which supervises the rest of the suite.

## Stage 3.

Type NEW and enter the following program.

```
10 HCR :BASE = 16384
20 HCOLOR= 3
30 FOR Y = 0 TO 191
40 HPL0T 0,Y
50 AZ = PEEK (38):BZ = PEEK (39): POKE 16384 + 2 * Y,AZ:
   POKE BASE + 2 * Y + 1,BZ
60 NEXT Y
70 REM DATA AT $4000-$417F
```

You do not save this program. Rather, run it and ignore the special effects. Press CONTROL-RESET and go to Stage 4. The program has generated a table of values which is needed by the machine code.

## Stage 4

Enter the machine code monitor by typing CALL — 151. You should see the '\*' prompt appear. Now type this lot:-

```
4190- FF FF FF FF FF FF 48 08      42D8- A9 20 8D BE 43 AD BF 43
4198- A9 20 85 30 A0 00 84 2F      42E0- 8D BD 43 20 58 43 20 55
41A0- B1 2F 49 FF 91 2F C8 CO      42E8- 43 20 67 43 AD BD 43 6A
41A8- 00 D0 F5 A6 30 E8 86 30      42F0- 8D BD 43 90 F1 20 55 43
41B0- E0 40 30 EC 28 68 60 FF      42F8- AD BD 43 49 FF 8D BD 43
41B8- FF 08 48 AD 00 CO 30 03      4300- AD BF 43 2A 90 OA AD BD
41C0- 4C CB 41 A9 00 8D 10 CO      4308- 43 18 6D BE 43 4C 43 43
41C8- 68 28 60 AD 62 CO 10 EB      4310- AD BD 43 18 6A 18 6A 18
41D0- A2 FF 8D 30 CO CA EO 00      4318- 6A 8D BD 43 C9 1B D0 08
41D8- 30 FB 4C BB 41 08 48 AD      4320- A0 01 8C BC 43 4C 4E 42
41E0- 00 CO 30 03 4C EF 41 A9      4328- C9 1F D0 08 A0 00 8C BC
41E8- 00 8D 10 CO 68 28 60 AD      4330- 43 4C 4E 42 AD BD 43 18
41F0- 61 CO 10 EB A2 FF 8D 30      4338- OA 6D BC 43 A8 B9 73 43
41F8- CO CA EO 00 30 FB 4C DF      4340- 18 69 80 20 49 43 4C 4E
4200- 41 08 48 AC 34 42 A9 90      4348- 42 C9 A0 90 07 C9 DB 08
4208- 8D 35 42 AE 33 42 EO 00      4350- 03 20 ED FD 60 20 58 43
4210- F0 03 AD 30 CO CE 35 42      4358- AE CO 43 A0 60 88 98 C9
4218- D0 13 A9 90 8D 35 42 88      4360- 00 D0 FA CA D0 F5 60 AD
4220- D0 0B AC 34 42 CE 36 42      4368- 61 CO OA A9 00 2A 4D C1
4228- D0 03 68 28 60 CA D0 E5      4370- 43 6A 60 05 05 45 33 OA
4230- 4C 0B 42 4A FE 31 01 01      4378- OA 41 2D 20 20 53 27 49
4238- FF FF 48 08 A9 00 8D BC      4380- 38 55 37 0D 0D 44 00 52
4240- 43 AD B3 43 A9 0E 8D CO      4388- 34 4A 87 4E 2C 46 25 43
4248- 43 A9 10 8D BF 43 AD 00      4390- 3A 4B 28 54 35 5A 22 4C
4250- CO 10 62 F0 60 A0 00 8C      4398- 29 57 32 48 00 59 36 50
4258- 10 CO C9 C6 D0 08 A9 01      43A0- 30 51 31 4F 39 42 3F 47
4260- 8D BC 43 4C 4E 42 C9 CC      43A8- 24 04 04 4D 2E 58 2F 56
4268- D0 08 A9 00 8D BC 43 4C      43B0- 3D 0B 0B 0E 0C 0B 08 06
4270- 4E 42 C9 C2 D0 08 A9 10      43B8- 05 04 02 01 01 14 20 10
4278- 8D BF 43 4C 4E 42 C9 C1      43C0- 0E 00 42 48 08 A9 FE 8D
4280- D0 08 A9 80 8D BF 43 4C      43C8- 60 45 AD 00 CO 10 OA FO
4288- 4E 42 C9 9B F0 24 C9 D3      43D0- 08 A9 00 8D 10 CO 28 68
4290- D0 08 AD C1 43 49 01 4C      43D8- 60 20 E8 44 30 03 4C CA
4298- 4E 42 C9 B0 90 B0 C9 BA      43E0- 43 A0 00 8C 62 45 AC 62
42A0- B0 AC 38 E9 B1 8D CO 43      43E8- 45 C8 D0 02 A0 FF 8C 62
42A8- A8 B9 B3 43 8D CO 43 4C      43F0- 45 20 0D 45 20 E8 44 30
42B0- 4E 42 28 68 60 AD 62 CO      43F8- ED AD 62 45 C9 05 90 D9
42B8- 30 03 4C 4E 42 20 67 43      4400- AD 60 45 C9 00 FO 17 10
42C0- 90 8C AD BF 43 C9 80 D0      4408- 15 AD 64 45 OA CD 62 45
42C8- OF AD CO 43 C9 OE FO 08      4410- 90 04 18 4C 17 44 38 AD
42D0- A9 80 8D BE 43 4C DD 42      4418- 60 45 2A 8D 60 45 AD 5E
```

```

4420- 45 8D 5D 45 AD 64 45 8D
4428- 63 45 AC 62 45 8C 5C 45
4430- 20 BC 44 AD 5D 45 8D 5E
4438- 45 AD 63 45 8D 64 45 AD
4440- 66 45 OA BO OB CD 64 45
4448- BO 06 AD 64 45 8D 66 45
4450- AO 00 8C 65 45 EE 65 45
4458- AC 65 45 FO 2C 20 OD 45
4460- 20 E8 44 FO FO 10 EE AD
4468- 66 45 OA BO 27 CD 65 45
4470- BO 22 OA BO OB 18 6D 66
4478- 45 BO 05 CD 65 45 90 09
4480- 20 9A 44 20 EC 44 4C C5
4488- 43 20 EC 44 A9 AO 20 ED
4490- FD 4C C5 43 20 9A 44 4C
4498- CA 43 AC 65 45 8C 5C 45
44A0- AD 66 45 8D 63 45 AD 5F
44A8- 45 8D 5D 45 20 BC 44 AD
44B0- 5D 45 8D 5F 45 AD 63 45
44B8- 8D 66 45 60 AD 5C 45 OA
44C0- BO OE CD 5D 45 BO 09 AD
44C8- 5C 45 8D 63 45 4C E1 44
44D0- AD 5D 45 OA BO OB CD 5C
44D8- 45 BO 06 AD 5D 45 8D 63
44E0- 45 AD 5C 45 8D 5D 45 60
44E8- AD 62 CO 60 AO 00 AD 60
44F0- 45 D9 28 45 FO OA C8 CO
44F8- 34 D0 F3 A9 DF 4C 09 45
4500- 8C 61 45 AD 61 45 18 69
4508- A7 20 ED FD 60 8C 61 45
4510- AO 06 A2 20 CA EO 00 FO
4518- 03 4C 14 45 88 CO 00 FO
4520- 03 4C 12 45 AC 61 45 60
4528- 9E D6 AD CA C8 B3 A1 95
4530- D2 DF CF C7 C3 C1 CO D0
4538- D8 DC DE B8 AA 00 D1 7F
4540- 8C 85 F9 E8 EA F4 FC E2
4548- F6 E0 F8 E7 F5 E4 FB FA
4550- F7 E6 ED F2 FO FD F1 E1
4558- F3 E9 EB EC 00 00 00 00
4560- 00 00 00 00 00 00 00 FF
4568- 48 08 A9 00 8D 62 46 8D
4570- 63 46 85 2F 8D 10 CO A9
4578- 40 85 30 A9 40 8D 65 46
4580- AO 30 20 32 46 C9 00 30
4588- F9 88 CO 00 10 F4 20 32
4590- 46 C9 00 10 F9 FO F7 AD
4598- 00 CO 30 OD A5 30 C9 40
45A0- FO OF AD 62 46 C9 3F 30
45A8- 08 A9 00 8D 10 CO 28 68
45B0- 60 A9 05 8D 64 46 AE 64
45B8- 46 CA 8E 64 46 AD 62 46
45C0- 18 2A A8 B1 2F 85 26 C8
45C8- B1 2F 85 27 AD 65 46 18
45D0- 2A 8D 65 46 C9 80 D0 1B
45D8- A9 01 8D 65 46 AC 63 46
45E0- C8 8C 63 46 CO 28 DO OB
45E8- 20 43 46 A2 00 8E 63 46
45F0- 4C 12 46 20 32 46 30 0D
45F8- AC 63 46 AD 65 46 11 26
4600- B1 26 4C BD 45 AC 63 46
4608- AD 65 46 11 26 91 26 4C
4610- BD 45 AE 64 46 EO 00 10
4618- 9D FO 9B AE 62 46 E8 8E
4620- 62 46 EO 80 30 39 A2 00
4628- 8E 62 46 A2 41 86 30 4C
4630- 97 45 A2 31 CA 48 68 08
4638- 28 EO 00 DO F7 AD 61 CO
4640- 49 FF 60 A2 BE 8C 66 46
4648- CA AO 93 88 CO 00 DO FB
4650- EO 00 DO F4 AO 7D 88 CO
4658- 00 DO FB AC 66 46 60 4C
4660- 97 45 00 00 00 00 00 DO
4668- FB AC 75 46 60 4C 97 45
4670- 32 28 FE 01 7F 28 FF FF

```

## Memory allocation

It may be useful to have the memory allocation of the machine code segments listed here, although they are available from the assembly listings. If you find a bug in a particular routine, then you can more easily locate your typing error by narrowing down the search!

Code	Start address
SCREEN ADDRESSES	\$4000
BLANK	\$4182
SCREEN INVERT	\$4196
MORSE MONITOR	\$41B9
RTTY MONITOR	\$41DD
STONE GENERATOR	\$4201
RTTY CODE	\$423A
CW CODE	\$43C3
FAX CODE	\$4568
END	\$4666

## Operating the programs

Since the supervising program is written in BASIC, there was no problem putting in some 'user friendliness'. Thus, there is a main menu and, for each, a sub menu. The main menu looks like this:-

```

1 FAX
2 RTTY
3 CW
4 END
SELECT;

```

### FAX (main menu choice 1).

Assuming you have the decoder box switched to FAX and that the radio is choofing along on a suitable station, the FAX menu choice 1 (and a keypress prompt) will start you running a picture. Tune the radio so that lots of action takes place on the screen.

If the transmitted picture is already partially sent at this stage, the picture you see will have a great stripe down its innards somewhere. This is because the program doesn't know where the border is. You see, the trick is to wait 'till the picture is about to start. That is announced by a lengthy period of regular 'pip-pip' tones. The keypress offered you is designed for that stage. Hit any key during those 'pips' and the picture will synchronise nicely.

If the picture seems predominantly white, then you are on the wrong sideband. Either switch over next time or receive it now and invert the picture when it is finished (you lose resolution that way). At any stage during the display of a picture, you may exit to the main program by pressing any key, by the way.

The printer option built in will work straight off with an 'Epson' card. Look at the BASIC code at line 1220 if it doesn't. Modify it to suit 'how to dump HI-RES page 1' according to your printer manual. The printer picture (as with all Apple picture dumps) is squashed vertically by a factor of 0.8. There is a way to get around this. You increase the vertical length of the picture on the screen by that factor. Trouble is though, you lose the last 10% of the picture. Can you imagine the fun I had at that stage when I remembered that?

If the picture slopes badly left or right, try trimming the speed. Lower numbers make the thing slope more right. The coarse adjustment is at location \$4644 and the fine at \$4655. There is also an adjustment for the width of the picture. I have left it a maximum. As noted in the Moffat article, some experimenting is required. The Apple timing varies from machine to machine, but not a great deal. It will not affect CW or RTTY.

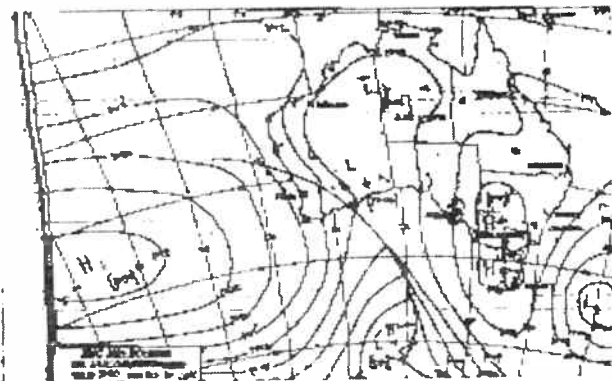
Note that this code fits in memory just after the tables generated by the previous stage. The entire code is now save to disk:

BSAVE MORFART, A\$4000,L\$700

(Short for MORse, Fax and Radio Teletype — not a pun on a surname)

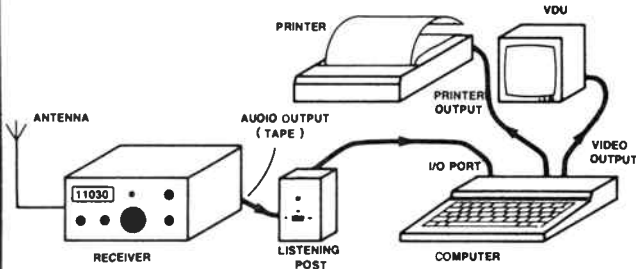
### Stage 5.

Type PR#6 and see if it all works!



Here's a couple of FAX samples, from station AXM on 5100 kHz.

# LISTENING POST SOFTWARE



Decode **RADIOTELETYPE/RADIO FACSIMILE PICTURES** &/or **CW** using your computer and the AEM3500 Listening Post project.

Software for our very popular AEM3500 Listening Post project, from the first issue (July '85) is available, on either cassette or disk, to suit any model Microbee, the Commodore 64 and Apple II-series computers.

All it costs is just:

**\$17.00**

plus \$2.50 post & handling

All you have to do is ● send us a blank C10 cassette, or a formatted 3.5" or 5.25" diskette (to suit your machine). ● Fill out the address label below and firmly attach it to your tape or diskette ● Complete the COUPON and send it to us, together with your labelled tape or diskette, enclosing payment by cheque or Money Order or you Credit Card details

Enclose your blank tape or diskette in a jiffy bag for protection. Put 5.25" diskettes between stiff cardboard

All mail orders will be despatched by certified mail

Please allow for normal turnaround post delays prevailing at time of sending order

We will gladly re-record any software that does not run

Fill in and cut out this coupon, cut off and attach the return address label to you tape or diskette and send it to

**LISTENING POST SOFTWARE**  
Australian Electronics Monthly  
PO Box 289, WAHROONGA 2076 NSW

## COUPON

Yes please! Rush me software for the Listening Post. I require the software on suit the:

<b>Microbee &amp;</b>	<b>Commodore 64</b>	<b>Apple II</b>
..... C.10oh 8510-type	.....	.....
..... Epson FX80-type printer	(most printers)	(most printers)

(tick appropriate one). **★ When sending a disk, please ensure it is already formatted ★**

Cost: \$17.00 plus \$2.50 post & handling

**TOTAL: \$19.50**

I enclose payment by:

Credit Card No.:

Expiry Date: .. / .. / ..

Signed: .....  
(Unsigned orders cannot be accepted)

Cheque or Money Order No. ....  
(\* Please make cheques or Money Orders payable to 'Australian Electronics Monthly')

## RETURN-ADDRESS LABEL

**RUSH ME TO:** ..... (name)

Address .....

..... Postcode .....

Try station on AXM 5100 kHz or AXI on 10 555 kHz and use USB. You get good FAX pictures and RTTY at 50 baud. It is also a good one for telling the difference 'twixt RTTY and FAX.

### RTTY (main menu option 2)

This mode is the most complex to operate and gave the most headaches in the development stage. The main problem I had was getting test signals. Anyway, you have a tune-up mode which should allow you to simulate the sound of RTTY from the receiver.

The 'invert' option should only be used when the radio set can't be switched from upper to lower sideband. (That effectively inverts the code). Listening to lots of RTTY teaches you the requisite operating skills. The RTTY tones should be such that most of the sound is low pitched. When data is firing along, the tone should jump high for lots of little instants.

If the printer races along with lots of repeated letters (in strings of the same letter) then select a lower speed. You simply press 1-9 from within the executing machine code for that. A '1' gives the lowest speed. In the unlikely case that ASCII is being sent, try pressing A. If there appears to be lots of numbers, press 'L' to force it back to letters. ('F' forces it to figures). You can return to the BASIC menu by pressing 'ESC'.

I wrote the audio invert option as part of the BASIC code and made 'it hard to get at', since the option should not be needed. I also gave a carrier/no carrier option. That allows the program to be used on signals of different quality. Again, not too useful.

The default conditions (if you don't do any choosing) are —

Speed	1 (45.5 Baud)
Mode	Baudot
Sense	Mark = high tone
Case	Expects letters
Carrier	Expects a carrier

### CW (Main menu choice 3)

The operation of this section of code is pretty straightforward. Tune in a CW signal using the LED indicator on the decoder as a guide. Selecting the 'tune-up' mode from the inner menu will allow you to listen to the computer reproducing the code. The reason that I included such a routine was to convince you that the received signal must be relatively clean and spike free to be really successful. The decoder is a little too simple for CW. What is needed is a sharp audio filter in front of it . . .

If the morse printout is full of Es and Ts then you must select the high speed option. If it is full of spaces, select the low speed option. Allow a few seconds for the speed to stabilize though. If the stuff just won't decode, try monitoring the code and see if it is clean. Perhaps the sending is just too gunky for the computer to understand. Those nasty noise spikes really throw the speed routine. I have included a certain amount of 'de-glitching' in the machine code but the software can only do so much if you hit it with noisy input.

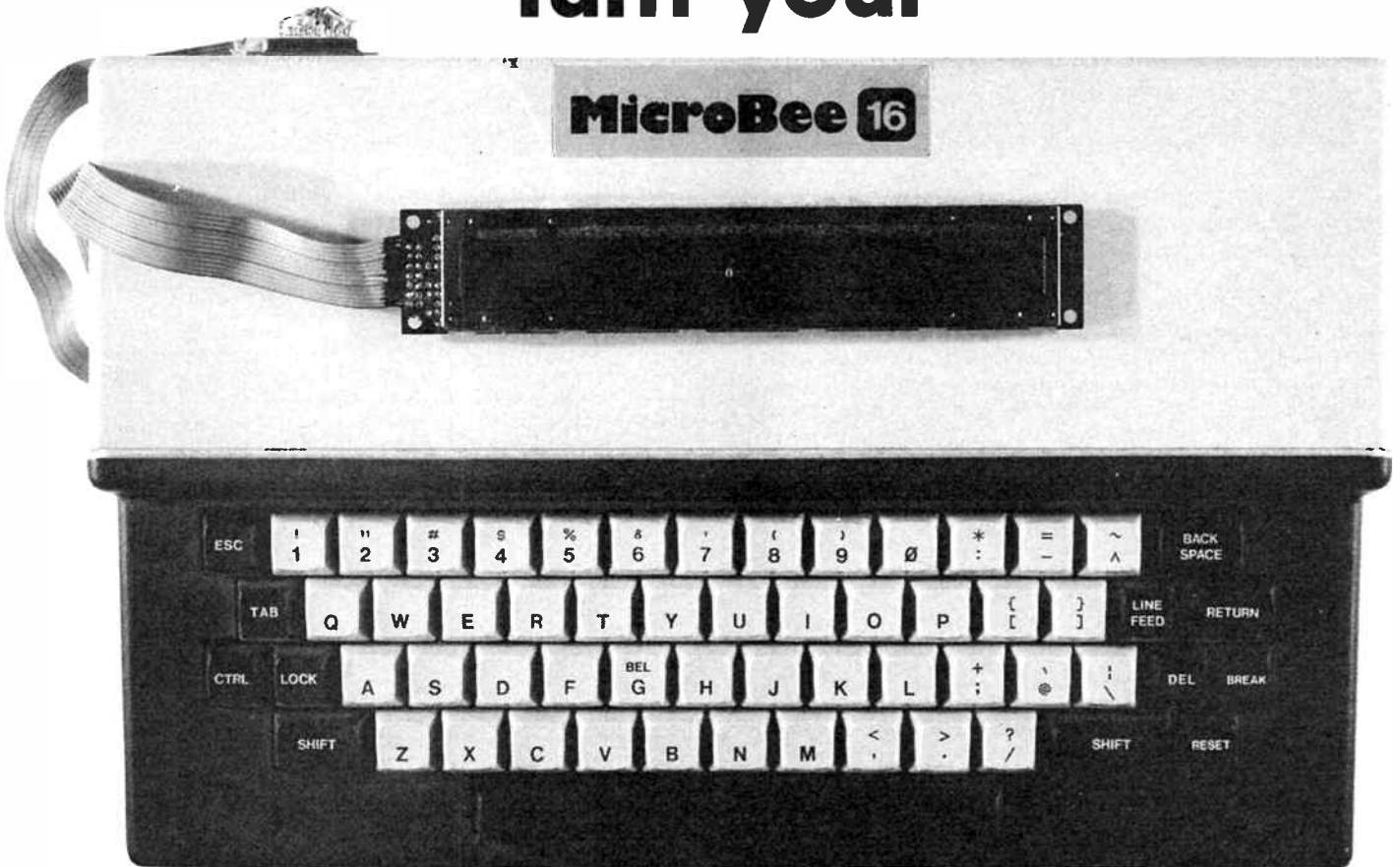
Try adjusting the audio level trimpot if you have included it. That can often lead to improved signal-to-noise ratio.

I hope you enjoy using the Apple package as much as I do. Good decoding! 🐸

Commented, disassembled listings of the C64 and Apple II Listening Post programs were too large (8-10 pages!) to reproduce, but photostats can be obtained from the magazine for \$2.50 post paid. Please mark your request "C64 Commented Listing," or "Apple II Commented Listing," as required.

**NOTE:** The July '85 issue (No. 1!) contained the original Listening Post article. If you want a back copy, or a photostat of the article, either costs just \$3.60, post paid anywhere in Australia, or A\$4.60 to NZ or PNG.

## Turn your



## into a 'Port-A-Bee'

### Paul Leonardi

If you've ever needed a 'portable' Microbee – this project's for you! Just attach a readily available liquid crystal display and run a little software – bingo, the 'Port-A-Bee'!

THIS PROJECT SHOWS HOW to attach a two-line by 40 character liquid crystal display (LCD) to your ROM-based Microbee to enable you to do limited operations *without* the video monitor. It was initiated by my need for a high quality daisy wheel printer. How, I can hear you asking, does that lead to a project for an LCD for the Microbee? Well, the story goes like this . . .

I already have a good quality printer ( a HP Thinkjet) but wanted letter quality print sometimes. To my wife, I couldn't justify the second printer (it was hard enough with the first one) and knowing of a very nice printer at work, I thought I would use that. Doing that involved getting up a little earlier to put the Microbee and monitor in the car, unloading it at the other end, finding power and cables then printing out the Wordbee file on the daisywheel. Then, of course, came the repacking and subsequent unpacking again back at home.

As you can see, this was all quite laborious and time consuming, so I decided that maybe it would be easier if I just took the 'Bee itself and a 12 V battery, then it would all fit in my case, thus saving time and energy.

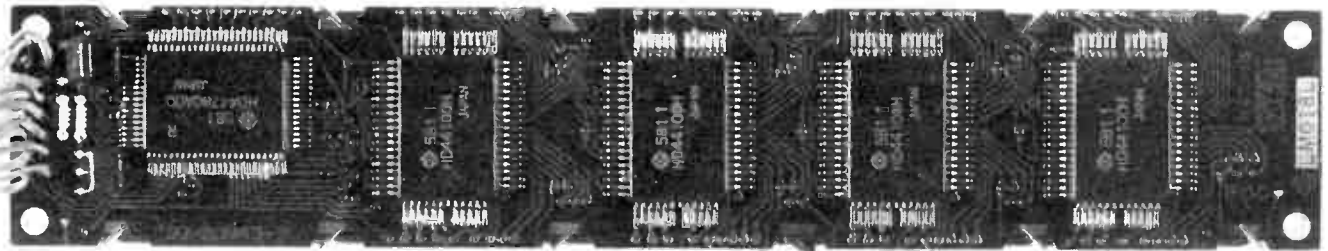
The ROM-based 'Bee (I have a 32K IC series) has the advantage of battery backup so that the file can be loaded in the night before. But once you connect the printer-'Bee-battery you're missing the very important user interface (something to see what the 'Bee is doing). That doesn't matter. You power up the 'Bee in BASIC (it beeps, remember), type (very carefully) the incantation EDASM (to go to WORD-BEE) then, presuming we're looking at a file, hit the linefeed key to go to command level Wordbee; then hit the P key followed by the return key. If all goes well the printer starts up. If not, you try the incantation a couple of times more and either it works or give up in disgust.

I swore that, if ever there was a cheap LCD that would connect to the 'Bee so that I could see what was happening, I'd get one.

After a little research, I discovered a range of displays from Hitachi. They range from 1-line by 8-characters to 2-lines by 40-characters, with a 200-by-640 graphics one available also.

To suit my purpose, the 2 x 40 display, known as the LM018L, seemed to suffice. Although this project is written around this display it is left sufficiently open so that similar

# aem project 4503



Rear view of the LCD. Thank goodness you don't have to build it!

Energy Control, PO Box 6502, Goodna Qld 4300. (07) 288 2455. They cost around \$70. Other types may be used, of course, but this Hitachi display was the best value.

This project describes how to connect the unit to the port, (notice there is no external hardware except for the 15-pin D-type plug) and the routines have needed to drive the LCD. I have provided some applications, such as LISTING and printing to the display from BASIC, and a small game incorporating the PCG abilities of the display. Note that it can be attached to both ROM-based and disk-based Microbees.

## The LMO18L display (and similar)

The LM018L liquid crystal display is a unit incorporating all the circuitry needed to accept ASCII information from the real world, convert it to dot representations of the alphabetic characters, then convert them to voltage signals to pulse the correct dots on the LCD, thus displaying the information to us. It runs from a single 5 V supply ( $\pm 2$  V) at an incredible 0.5 mA typical. Thus can be supplied from port A. It has 14 lines for connection to the real world. Three are used for the power circuit, eight for the data bus, and three control lines. In fact, it can be reduced to four lines of data bus (as is the case here), reducing the lines to the real world to 10.

Figure 1 shows a block diagram of the LM018L. It ties together one LCD, four 60-pin flat pack ICs (HD44100H) and one 80-pin flat pack IC (HD44780A00). Each 44100H has the guts to drive 20 characters of 8-by-5 dot matrix display. With the 44780 doing all the heavy work of I/O buffering, instruction decoding, character generation (in ROM) and user characters (in RAM), timing generation, parallel-to-serial conversion, cursor control, display data RAM, common and segment signal drivers and a 40-bit shift register. The 44780 is so full of features it would take too long to describe it here, so I will be describing only the parts necessary to understand the operation for this project.

## Operation

The unit can be operated in two modes using the 4-bit data bus or the 8-bit data bus. As we have only active lines on port

A and the LCD requires three control lines, in addition to the bus, we have to run it in the 4-bit data bus mode.

Figure 2 shows the timing diagram necessary to operate the LCD.

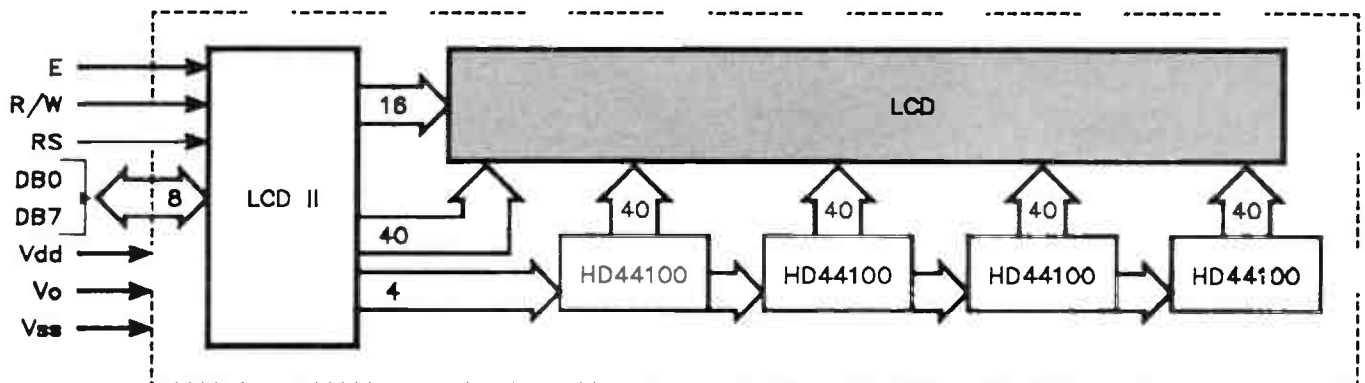
## TIMING CHARACTERISTICS

ITEM	Symbol	MIN	MAX	UNITS
Enable cycle time	Tcyc	1.0	-	us
Enable pulse width	Pweh	450	-	ns
Enable rise/fall time	Ter, Tef		25	ns
RS, R/W setup time	Tas	140		ns
Data delay time	Tddr		320	ns
Data setup time	Tdsw	225		ns
Hold time	Th	10		ns

The lines we have to connect from port A to the LCD are set up this way:

D15 plug	LM018L
D0 — pin 13 on the D15 plug <—>	DB4 — pin 11 on the LCD
D1 — pin 5 " <—>	DB5 — pin 12 on the LCD
D2 — pin 12 " <—>	DB6 — pin 13 "
D3 — pin 4 " <—>	DB7 — pin 14 "
D4 — pin 11 " <—>	RS — pin 4 "
D5 — pin 3 " <—>	R/W — pin 5 "
D6 — pin 10 " <—>	E — pin 6 "
5 V — pin 1 " <—>	Vdd — pin 2 "
0 V — pin 8 " <—>	Vss — pin 1 "
0 V — pin 8 " <—>	Vo — pin 3 "

Where: DB4-DB7 is the 4-bit data bus, RS is the 'register select' bit selecting between data register/instruction register; R/W is the read/write bit selecting the direction of data transfer along the 4-bit data bus (read from LCD or write to LCD); E is the enable bit and the clock bit for data transfer (see timing diagrams). Figure 3 shows the pin numbers and their functions on the LM018L and the 15-pin D-type plug for the Microbee port A.



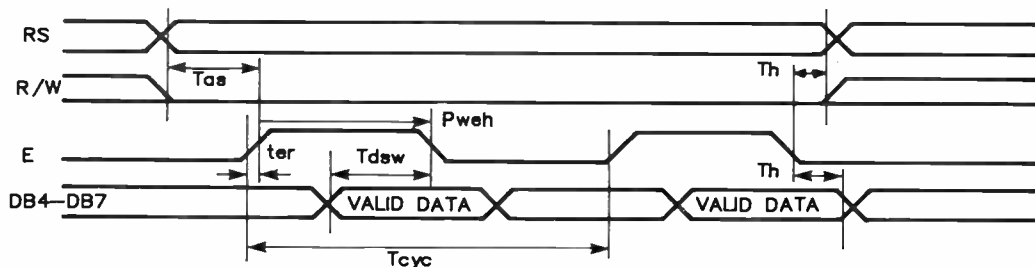


Figure 2.1

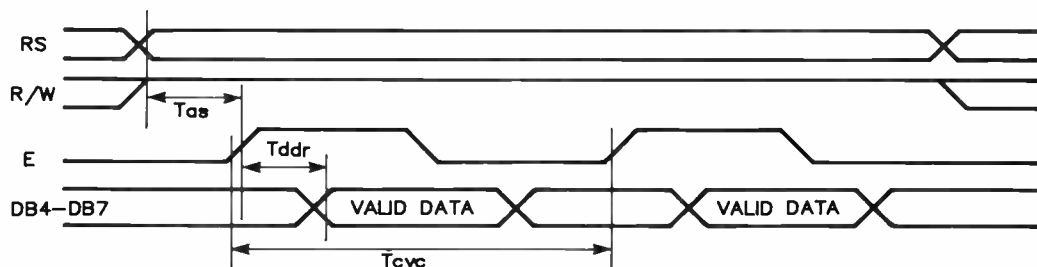
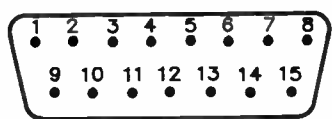
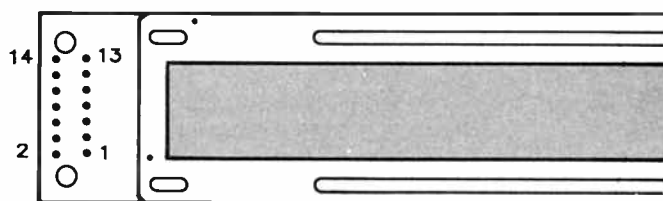


Figure 2.2.

DISPLAY TIMING DIAGRAMS



15 PIN D TYPE CONNECTOR (FRONT VIEW) MICROBEE PORT A



LIQUID CRYSTAL DISPLAY LM018L (HITACHI)

PIN	CONNECTION
1	+5 volt
2	A7
3	A5
4	A3
5	A1
6	—
7	—
8	GND
9	—
10	A6
11	A4
12	A2
13	A0
14	—
15	—

PIN	SYMBOL	FUNCTION
1	Vss	0 volt
2	Vdd	+5 Volt
3	Vo	0 volt
4	RS	Register select
5	'R/W	Read/Write
6	E	Enable
7	DB0	Data bus lines
8	DB1	
9	DB2	
10	DB3	
11	DB4	
12	DB5	
13	DB6	
14	DB7	

Figure 3. Port A and LM018L pinouts.

**The driver routines.**

As you can well imagine there is more to it than just connecting the wires between the LCD and port A. That's just the electrical and mechanical interface. Next is the functional interface, the procedures needed, for example, to initialize the LCD and the procedure to take the contents of the A register in the Z80 and make it appear on the LCD. This involves putting the top nibble of register A at positions D0-D3 on the PIO (port A driver), setting the R/W and RS bits, pulsing the enable line, setting the lower nibble of register A on the D0-D3 lines of the PIO, pulsing the enable line again and then release the control lines.

INIT is the first routine to be called as this sets up the LCD

to respond to the 4-bit data bus, 2-lines by 40-characters and make a 5-by-7 character font. It only needs to be called after power-up.

The output routines have been called OUTR1, OUTR1C, OUTR0 and OUTR0C, and mean OUT to register 1, and OUT to register 0 respectively. This means when the routines are called the contents of the A register is passed to the respective register in the LCD. Where the label is followed by C, such as in OUTR1C, it means the contents of the C register is output instead of the A register. This is especially useful for BASIC USR calls as the C register can be passed in these.

These are the most fundamental routines needed to communicate with the LCD.

# aem project 4503

**TABLE 1.**

INSTRUCTION	RS	R/W	DATA (HEX) (DEC)	DESCRIPTION	301B D300 301D C9	00470 00480 00490	OUT RET	(0),A	:	SET R/W BIT HIGH
CLEAR HOME	0	0	01H 1	CLEAR THE LCD AND HOMES CURS.						
ENTRY MODE	0	0	02H 2	RETURN THE CURSOR TO HOME POSN.	301E 47	00500	WRITE0	LD	B,A	: SAVE A REGISTER
	0	0	04H 4	CURSOR MOVES TO LEFT AFTER INPUT	301F CB3F	00510		SRL	A	: SHIFT RIGHT ONE
	0	0	05H 5	DISPLAY SHIFTS LEFT AFTER INPUT	3021 CB3F	00520		SRL	A	: SHIFT RIGHT ONE
	0	0	06H 6	CURSOR MOVES RIGHT AFTER INPUT	3023 CB3F	00530		SRL	A	: SHIFT RIGHT ONE
	0	0	07H 7	DISPLAY SHIFTS RIGHT AFTER INPUT	3025 CB3F	00540		SRL	A	: MOVE TOP OF A TO BOTTOM NIBBLE
DISPLAY	0	0	08H 8	DISPLAY OFF	3027 D300	00550		OUT	(0),A	: OUTPUT DATA ON BUS
	0	0	09H 9	CURSOR CHARACTER BLINKS.	3029 CD5330	00560		CALL	PULSEE	: PULSE THE ENABLE BIT
	0	0	0AH 10	CURSOR ON ONLY.	302C 78	00570		LD	A,B	: GET A AGAIN
	0	0	0BH 11	CURSOR ON AND CHARACTER BLINKS	302D E60F	00580	WRO5	AND	OFH	: SAVE BOTTOM NIBBLE
	0	0	0CH 12	DISPLAY ON	302F D300	00590		OUT	(0),A	: OUTPUT THE LOWER NIBBLE
	0	0	0DH 13	DISPLAY ON,CURSOR & BLINK OFF	3031 CD5330	00600		CALL	PULSEE	: PULSE ENABLE AGAIN
	0	0	0EH 14	DISPLAY & CURSOR ON, BLINK OFF	3034 CD9330	00605		CALL	DELAY	
	0	0	0FH 15	DISPLAY, CURSOR AND BLINK ON.	3037 C9	00610		RET		
CURSOR SHIFT	0	0	10H 16	MOVE CURSOR LEFT ONE POSITION.	3038 47	00620				
	0	0	14H 20	MOVE CURSOR RIGHT ON POSN.	3039 CB3F	00630	WRITE1	LD	B,A	: SAME AS WRITEO
	0	0	18H 24	SHIFT DISPLAY LEFT ONCE.	303B CB3F	00640		SRL	A	
	0	0	1CH 28	SHIFT DISPLAY RIGHT ONCE.	303D CB3F	00650		SRL	A	
FUNCTION SET	0	0	20H 32	DATA 4 BITS, 1 LINE 5*7 FONT.	303F CB3F	00660		SRL	A	
	0	0	24H 36	DATA 4 BITS, 1 LINE 5*10 FONT.	3041 C610	00670		ADD	A,BREGS	: SELECT REGISTER 1
	0	0	28H 40	DATA 4 BITS, 2 LINES 5*7 FONT.	3043 D300	00680		OUT	(0),A	
	0	0	2CH 44	DATA 4 BITS, 2 LINES 5*7 FONT.	3045 CD5330	00690		CALL	PULSEE	
	0	0	30H 48	DATA 8 BITS, 1 LINE 5*7 FONT.	3048 78	00700		LD	A,B	
	0	0	34H 52	DATA 8 BITS, 1 LINE 5*10 FONT.	3049 E60F	00710		AND	OFH	
	0	0	38H 56	DATA 8 BITS, 2 LINES 5*7 FONT.	04B C610	00720		ADD	A,BREGS	
	0	0	3CH 60	DATA 8 BITS, 2 LINES 5*7 FONT.	304D D300	00730		OUT	(0),A	
SET C6 RAM	0	0	40H 64	SETS C6 RAM TO ADDRESS 0H	304F CD5330	00740		CALL	PULSEE	
	0	0	XXH XX	SETS C6 RAM TO XXH-40H	3052 C9	00750		RET		
	0	0	7FH 127	SETS C6 RAM TO ADDRESS 3FH		00760				
SET DD RAM	0	0	80H 128	SETS DD RAM TO ADDRESS 0H		00770				
	0	0	XXH XXX	SETS DD RAM TO XXH-80H		00780				
	0	0	FFH 255	SETS DD RAM TO ADDRESS 7FH		00790				
WRITE DATA	1	0	XXH YXX	WRITES ASCII XXH TO CURRENT POSN EITHER C6 RAM OR DD RAM.		00800				

READING DATA FROM THE LCD.  
READING REGISTER 0 GIVES THE STATUS OF THE LCO WITH BIT 7 INDICATING THE BUSY FLAG, AND BITS 6-0 GIVING THE ADDRESS OF THE ADDRESS COUNTER. (i.e. WHAT POSITION IS THE CURSOR AT)

READING REGISTER 1 READS THE CHARACTER FROM THE 00 RAM (DISPLAY DATA RAM) OR THE C6 RAM (CHARACTER GENERATOR RAM) DEPENDING WHICH WAS LAST SET.

Table 1 lists the instructions the LCD has available. These functions are available for your use, simply by loading the A register (in the Z80) with the data specified and calling OUT0 or OUTR1 (depending whether you want to display some data, or setup the LCD unit).

The panel here shows a list of functions available and the data needed to effect these functions. (i.e. to clear the LCD and move the cursor to the home position you would need to put the data 01H into the LCD instruction register 0, or using the software provided here, load the A register of the Z80 and call OUTR0).

```

00100 ;*****
00110 ; LCD DRIVER ROUTINES FOR THE BEE
00120 ; BY PAUL LEONARDI 15-OCT-1985 VER 1.4
00130 ; CALL INIT FIRST TIME TO SETUP THE LCD
00140 ; CALL OUTRO TO WRITE LETTER TO THE DISPLAY
00150 ;*****
00160
00170 FUNCT EQU 028H ; SETS DATA 4. LINES 2,
; FONT 5*7
000E 00180 DON EQU 00EH ; DISPLAY ON, CURSOR ON
0008 00190 DOFF EQU 008H ; DISPLAY OFF
0001 00200 CLR EQU 001H ; CLEAR THE DISPLAY
0002 00210 HOME EQU 002H ; HOME CURSOR
0006 00220 EPMODE EQU 006H ; ENTRY MODE SET
0010 00230 BREGS EQU 010H ; REGISTER SELECT BIT
0020 00240 BRW EQU 020H ; READ WRITE BIT
0040 00250 BENAB EQU 040H ; ENABLE BIT
00260
3000 00270 ORG 3000H
00275 ;*****
3000 CD1130 00280 INIT CALL SETUP ; SET UP BITS AND PORTS
3003 CD5C30 00290 CALL RESET ; INITIALIZE LCD
; BY INSTRUCTION
00300
00305 ;*****
00310
00320 OUTR1C LD A,C ; BASIC PASSES VARIABLES
; IN BC PAIR
3008 CD3830 00330 OUTR1 CALL WRITE1 ; OUTPUT REGISTER A
; CONTENTS TO LCD
00340
00345 ;*****
00360
00370 OUTROC LD A,C ; BASIC PASSES VARIABLES
; IN BC PAIR
300C 79 00370 OUTROC LD A,C ; BASIC PASSES VARIABLES
; IN BC PAIR
300D CD1E30 00380 OUTRO CALL WRITE0 ; OUTPUT 180 A TO
; REGISTER 0 LCD
00390
00395 ;*****
00400
00410 ;SETUP P10
3011 3EFF 00420 SETUP LD A,OFFH ; IO INSTRUCTION TO P10
3013 D301 00430 OUT (1),A ; CONTROL REGISTER OF P10
3015 3E00 00440 LD A,0 ; 8 LINES OF OUTPUT
3017 D301 00450 OUT (1),A ; SELECT AS OUTPUT
3019 3E20 00460 LD A,BRW ; READ WRITE BIT

```

## Some applications.

Having the data, correct connections and the right driving routines we can now do some programming to use the LCD.

### 1) As a list device for BASIC.

Firstly, the LCD must be initialized by calling the routine at 3000H. From BASIC, this is as simple as USR(12288). Or, if you require, the initialization could be carried out automatically upon power-up by setting the warm-start vector at 00A2H to point to the BASIC program which calls the INIT routine with a USR(12288) call.

Next, to provide a pointer to the OUTR1 routine we could set up one of the output device vectors. If we decided to use vector 1, for example, we need to enter 11H & 30H into B4H & B5H respectively. Thus, a simple OUT #1 from BASIC would allow all listings to show up on the LCD. Program 1A is a machine code programme which sets up these pointers and initializes the LCD on power-up so that what you type into the Microbee is echoed on the LCD. You simply run this program once and reboot the system to start LCD listing. Thus, subsequent power-ups would allow communications to the LCD. The disk-based Microbee would have to setup an autostart .COM file as it isn't battery-backed.

Programme 1B is the all-BASIC version of this.



```

PROGRAM 1a
00100 *****
00110 : PROGRAM 1a - AFTER CALLING THIS PROGRAM
00120 : THE FIRST TIME, OUTPUT FROM BASIC WILL BE
00130 : ON THE LCD AS WELL AS THE MONITOR.
00140 : THE DRIVER ROUTINES ARE ASSUMED TO BE HARD
00150 : AT JOURNAL.
00160 : by P.LEONARDI 16-10-85 VER 1.1
00170 : *****
00180
3000 00190 INIT EQU 3000H
3007 00200 OUTR1C EQU 3007H
3008 00210 OUTR1 EQU 3008H
300C 00220 OUTR1D EQU 300CH
300D 00230 OUTR1E EQU 300DH
00240
3100 00250 ORG 1000H
3100 C0030 00260 START LABEL INIT ; INITIALIZE THE LCD
3103 210031 00270 LD MLC,TAKT ; ADDRESS OF
; WARM START VECTOR
3106 22A00 00280 LD C0A2H,HL ; NEXT WARM Takt
3109 210830 00290 LD MLC,OUTR1 ; ADDRESS OF
; OUTPUT ROUTINE
310C 22B400 00300 LD C0B4H,HL ; OUTPUT ADDRESS
310F 3E03 00310 LD A,HL ; INITIALIZATION
3111 32E200 00320 LD C0E2H,HL ; OUTPUT DEVICE Takt
3114 C31A85 00330 IF C031AH ; INIT WARM Takt
0000 00340 END
00000 Total errors

```

```

PROGRAM 1b - BASIC VERSION
0010 REM PROGRAM 1b - THE BASIC VERSION OF 1a
0020 REM IF YOU RUN THIS PROGRAM IT WILL SET UP THE PRINTER
0030 REM AND LINK TO ALLOW LISTENING ON THE LCD AS WELL AS THE
0040 REM SCREEN, by P.Leonardi 16-10-85 VER 1.1
0050 REM IT WILL ALSO INITIALIZE THE DISPLAY FROM F0000
0060 REM
0070 FOR A=12288 TO 12443
0080 READ B:POKE A,B
0090 NEXT A
0100 U=USR(12288):REM INITIALIZE THE LCD
0110 PWR 162,30:POKE163,128:REM WARM START START, THIS PROG
0120 FOR E 180,8:FOR E101,48:REM OUTPUT VECTOR POINTS TO LCD R1
0130 FOR E 226,3:REM OUTPUT DEVICE ADDRESS AND OUTPUT
0140 STOP
10000 REM data for pointing from 16000 to 16155 dec
10010 DATA 205, 17, 48, 205, 92, 48, 201, 121, 205, 56
10020 DATA 48, 201, 121, 205, 30, 48, 201, 62, 255, 211
10030 DATA 1, 62, 0, 211, 1, 62, 32, 211, 0, 201
10040 DATA 71, 203, 63, 203, 63, 203, 63, 203, 63, 211
10050 DATA 0, 205, 83, 48, 120, 230, 15, 198, 16, 211, 0, 205
10060 DATA 83, 48, 201, 147, 48, 201, 71, 203, 63, 203
10070 DATA 63, 203, 63, 203, 63, 198, 16, 211, 0, 205
10080 DATA 83, 48, 120, 230, 15, 198, 16, 211, 0, 205
10090 DATA 83, 48, 201, 205, 247, 211, 0, 203, 183, 211
10100 DATA 0, 201, 62, 3, 205, 45, 48, 205, 147, 48
10110 DATA 62, 3, 205, 45, 48, 205, 147, 48, 62, 3
10120 DATA 205, 45, 48, 62, 3, 205, 45, 48, 62, 40
10130 DATA 205, 30, 48, 62, 8, 205, 30, 48, 62, 1
10140 DATA 205, 30, 48, 205, 147, 48, 62, 6, 205, 30
0150 DATA 48, 62, 14, 205, 30, 48, 201, 14, 255, 62
0160 DATA 0, 229, 229, 16, 250, 201

```

## 2) To use the display from BASIC as an OUTPUT medium.

Programme 2 is a little self-contained program which will do nothing more than print some information on the LCD, show how to shift the display (by using the USR BASIC statement), etc.

```

00100 REM PROGRAMME 2 - A BASIC PROGRAMME TO RUN THE LCD FROM
00110 REM BASIC USING USR STATEMENTS AND WRITING CODES INTO
00120 REM THE REGISTERS OF THE LCD.
00130 REM by P.Leonardi 16-10-85 VER 1.1
00140 REM
00150 REM USR(12288) : INITIALIZES THE LCD
00160 REM USR(12295,X) : PUTS THE VALUE X INTO LCD REG 1
00170 REM USR(12300,X) : PUTS THE VALUE X INTO LCD REG 0
00180 REM *****
00190 CLS
00200 GOSUB 3200:REM CALL THIS TO LOAD THE DRIVERS
00210 USR(12288):REM INITIALIZE THE LCD
00220 I=USR(12300,1) : REM CLEAR LCD
00230 PRINT "HIT SOME KEYS TO TRANSFER THEM TO THE LCD, FOLLOWED BY :RET:"
00240 A1$=EY:IFA1$=""THEN GOTO 240
00250 I=USR(12295,ASC(A1$)) : REM PUTS A CHAR ON THE LCD
00260 IF A1$<>CHR(13) THEN GOTO 240
00270 PRINT "SHIFT THE DISPLAY RIGHT TEN TIMES, HIT :RET:"
00280 A1$=EY:IFA1$=""THEN GOTO 280
00285 FOR A=1 TO 10
00290 I=USR(12300,28) : REM SHIFTS DISPLAY RIGHT
00300 NEXT A
00305 PRINT "TO CLEAR LCD AND GO AGAIN, HIT THE :RET:"
00306 A1$=EY:IFA1$=""THEN GOTO 306
00310 GOTO 220
00320 FOR A=12288 TO 12443
00330 READ B:POKE A,B
00340 NEXT A
00350 RETURN
00360 REM data for pointing from 16000 to 16155 dec
00370 DATA 205, 17, 48, 205, 92, 48, 201, 121, 205, 56
00380 DATA 48, 201, 121, 205, 30, 48, 201, 62, 255, 211
00390 DATA 1, 62, 0, 211, 1, 62, 32, 211, 0, 201
00400 DATA 71, 203, 63, 203, 63, 203, 63, 203, 63, 211
00410 DATA 0, 205, 83, 48, 120, 230, 15, 198, 16, 211, 0, 205
00420 DATA 83, 48, 201, 147, 48, 201, 71, 203, 63, 203
00430 DATA 63, 203, 63, 203, 63, 198, 16, 211, 0, 205
00440 DATA 83, 48, 120, 230, 15, 198, 16, 211, 0, 205
00450 DATA 83, 48, 201, 205, 247, 211, 0, 203, 183, 211
00460 DATA 0, 201, 62, 3, 205, 45, 48, 205, 147, 48
00470 DATA 62, 3, 205, 45, 48, 205, 147, 48, 62, 3
00480 DATA 205, 45, 48, 62, 3, 205, 45, 48, 62, 40
00490 DATA 205, 30, 48, 62, 8, 205, 30, 48, 62, 1
00500 DATA 205, 30, 48, 205, 147, 48, 62, 6, 205, 30
00510 DATA 48, 62, 14, 205, 30, 48, 201, 14, 255, 62
00520 DATA 0, 229, 229, 16, 250, 201

```

## 3) To show some of the features of the LCD and its graphics ability.

Program 3 is a little game, a take-off from Cannibals & Mis-

sionaries, called 'Feminists and Chauvinists', as the 7 x 5 font for PCG characters would not allow enough distinction between Cannibals and Missionaries. (The feminists play the same roll as the Cannibals!!)

It's written in BASIC (rather inefficiently, I'm sorry), and is quite long. So, if you don't want to type it in you may just like to view it as an example, or you can get a disk or tape of all the programs in this project by writing to the magazine (see accompanying advertisement).

```

00100 REM PROGRAMME 3 - A BASIC LCD GAME USING
00110 REM LCD GRAPHICS AND TEXT.
00120 REM *** FEMINISTS AND CHAUVINISTS ***
00130 REM by P.Leonardi 20-10-85 VER 1.0
00140 REM
00150 R=1:W=0
00160 C=1:F=3:D=0:G=0
00170 N=0:P=1
00180 REM USR(12288) : INITIALIZES THE LCD
00190 REM USR(12295,X) : PUTS THE VALUE X INTO LCD REG 1
00200 REM USR(12300,X) : PUTS THE VALUE X INTO LCD REG 0
00210 REM *****
00220 CLS
00230 GOSUB 840:REM CALL THIS TO LOAD THE DRIVERS
00240 U=USR(12288):REM INITIALIZE THE LCD
00250 U=USR(12300,64):REM NOW WE TALK TO CHARACTER GEN RAM
00260 GOSUB 1450:REM CG RAM SETUP
00270 CLS
00280 GOSUB 1200:REM ASK PLAYER
00290 IF X=F OR Y=C:BI$="" NOT ENOUGH PEOPLE THERE "IGOSUB1:001GOSUB1:301GOTO120
80
00300 F=F-X:Y=Y-D:W=W+Y:G=G+X
00310 GOSUB 1250
00320 GOSUB 890
00330 GOSUB 460
00340 GOSUB 1030
00350 GOSUB 1410
00360 IF G=3:IF D=3:BI$="" YOU HAVE SAVED THE DAY "IGOSUB1:301STOP
00370 GOSUB 1180
00380 IF X=G OR Y=D:BI$="" NOT ENOUGH PEOPLE THERE"IGOSUB1:001GOSUB1:301GOTO1370
00390 GOSUB 1250
00400 U=G-X:D=D-Y:V=C+Y:F=F+X
00410 GOSUB 1030
00420 GOSUB 610
00430 GOSUB 890
00440 GOSUB 1410
00450 GOTO 270
00460 REM *** take boat right ***
00470 FOR A=202 TO 219
00480 I=USR(12300,A-1)
00490 I=USR(12295,32)
00500 I=USR(12295,5)
00510 I=USR(12295,6)
00520 I=USR(12295,6)
00530 I=USR(12295,7)
00540 I=USR(12300,A-64)
00550 I=USR(12295,32)
00560 I=USR(12295,N)
00570 I=USR(12295,P)
00580 REM PLAY 20,1
00590 NEXT A
00600 I=USR(12300,A-63)
00610 I=USR(12295,32)
00620 I=USR(12295,32)
00630 RETURN
00640 REM *** take boat & cont left ***
00650 FOR A=219 TO 201 STEP -1
00660 I=USR(12300,A)
00670 I=USR(12295,5)
00680 I=USR(12295,6)
00690 I=USR(12295,6)
00700 I=USR(12295,7)
00710 I=USR(12295,32)
00720 I=USR(12300,A-64)
00730 I=USR(12295,N)
00740 I=USR(12295,P)
00750 I=USR(12295,32)
00760 REM PLAY 10,1
00770 NEXT A
00780 I=USR(12300,A-64)
00790 I=USR(12295,32)
00800 I=USR(12295,32)
00810 RETURN
00820 STOP
00830 REM *** MACHINE CODE ROUTINE
00840 FOR A=12288 TO 12443
00850 READ B:POKE A,B
00860 NEXT A
00870 RETURN
00880 REM ** display people left **
00890 U=USR(12300,128):REM NOW WE TALK TO DISPLAY RAM
00900 IF C=0:GOTO 940
00910 FOR A=1 TO C
00920 U=USR(12295,M)
00930 NEXT A
00940 IF F=0:GOTO 980
00950 FOR A=1 TO F
00960 U=USR(12295,W)
00970 NEXT A
00980 IF C=F:W=5:GOTO 1020
00990 FOR A=0 TO 5:C=F
01000 U=USR(12295,32)
01010 NEXT A
01020 RETURN
01030 REM ** DISPLAY THE PEOPLE RIGHT ***
01040 U=USR(12300,161)
01050 IF D=0:GOTO 1090
01060 FOR A=1 TO D
01070 U=USR(12295,M)
01080 NEXT A
01090 IF G=0:GOTO 1140
01100 FOR A=1 TO G
01110 U=USR(12295,W)
01120 NEXT A
01130 IF D=G:W=5:GOTO 1170
01140 FOR A=0 TO 6:D=G
01150 U=USR(12295,32)
01160 NEXT A
01170 RETURN
01180 CLS
01190 REM **** ASK HOW MANY* ON LCD****
01200 BI$="" HOW MANY FEMINISTS? "IGOSUB1:301INPUT X:IF X=2:Y=0:GOTO1240
01210 BI$="" HOW MANY CHAUVINISTS? "IGOSUB1:301INPUT Y "IGOSUB1:300INPUT Y
01220 IF X*Y:BI$=""NEED AT LEAST 1 PERSON"IGOSUB1:301GOSUB1:301GOTO1200

```

# PORT-A-BEE SOFTWARE

If you would like to have the facility of a portable Microbee, while still retaining all its normal functions, as described in AEM Project 4503, but don't want to go through the tedious routine of typing-in all the software (with the possibility of having to debug your mistakes), you can obtain the full suite of software on either tape or 3.5" disk.

All it costs is just:

**\$17.00**

plus \$2.50 post and handling

All you have to do is:

- send us a blank C10 cassette, or
- a formatted 3.5" disk.
- complete the COUPON and return-address label below and send it to us, together with your labelled tape or disk, enclosing payment by cheque, money order or your Credit Card details.

Please allow for normal turnaround post delays prevailing at time of order.

We will gladly re-record any software that does not run.



Send completed coupon to:

Port-A-Bee Software  
 Australian Electronics Monthly  
 PO BOX 289 WAHROONGA 2076 NSW

## COUPON

Please rush me software for the Port-A-Bee project (AEM Project 4503).

Cost: \$17.00 plus \$2.50 post & handling  
**TOTAL: \$19.50**

I enclose payment by:

Credit Card No.:

Expiry Date: . . . / . . . / . . .

Signed: .....  
 (Unsigned orders cannot be accepted)

Cheque or Money Order No. ....  
 (\* Please make cheques or Money Orders payable to 'Australian Electronics Monthly')

### RETURN-ADDRESS LABEL

**RUSH ME TO:** ..... (name)

Address .....

..... Postcode .....

## aem project 4503

```

01230 IF X=Y>2:BI$="TOO MANY PEOPLE IN BOAT":GOSUB1300:GOSUB1390:GOTO1200
01240 RETURN
01250 IF Y=2:P=M:N=M
01260 IF X=1:N=W
01270 IF Y=1:P=M
01280 IF X=2:P=W:N=W
01290 RETURN
01300 REM # SCREEN PRINT LCD ROUTINE
01310 REM CENTRE AT 148
01320 A=148-(LEN(BI$)/2)
01330 I=USR(12300,A)
01340 FOR A=1 TO LEN(BI$)
01350 I=USR(12295,ASC(BI$(A,A)))
01360 NEXT A
01370 RETURN
01380 REM TIME WAIT
01390 FOR A=1 TO 1000:NEXTA:RETURN:REM TIME DELAY
01400 REM *** BLEW IT ROUTINE
01410 BI$=" BLEW IT, THE FEM: GOT YOU"
01420 IF C=0:IF F=C:GOSUB1300:STOP
01430 IF D=0:IF G=D:GOSUB1300:STOP
01440 RETURN
01450 REM *** SET UP CG RAM ****
01460 FOR A=1 TO 64
01470 READB
01480 U=USR(12295,B)
01490 NEXT A
01500 GOSUB 890
01510 I=USR(12300,168)
01520 FOR A=1 TO 7
01530 I=USR(12295,2)
01540 NEXT A
01550 I=USR(12295,2)
01560 I=USR(12295,3)
01570 I=USR(12295,32)
01580 I=USR(12295,5)
01590 I=USR(12295,6)
01600 I=USR(12295,6)
01610 I=USR(12295,7)
01620 I=USR(12300,224)
01630 I=USR(12295,4)
01640 FOR A=1 TO 7
01650 I=USR(12295,2)
01660 NEXT A
01670 RETURN
01680 DATA 205, 17, 48, 205, 92, 48, 201, 121, 205, 56
01690 DATA 48, 201, 121, 205, 30, 48, 201, 62, 295, 211
01700 DATA 1, 62, 0, 211, 1, 62, 32, 211, 0, 201
01710 DATA 71, 203, 63, 203, 63, 203, 63, 203, 63, 211
01720 DATA 0, 205, 83, 48, 120, 230, 15, 211, 0, 205
01730 DATA 83, 48, 205, 147, 48, 201, 71, 203, 63, 203
01740 DATA 63, 203, 63, 203, 63, 198, 16, 211, 0, 205
01750 DATA 83, 48, 120, 230, 15, 198, 16, 211, 0, 205
01760 DATA 83, 48, 201, 203, 247, 211, 0, 203, 183, 211
01770 DATA 0, 201, 62, 3, 205, 45, 48, 205, 147, 48
01780 DATA 62, 3, 205, 45, 48, 205, 147, 48, 62, 3
01790 DATA 205, 45, 48, 62, 2, 205, 45, 48, 62, 40
01800 DATA 205, 30, 48, 62, 8, 205, 30, 48, 62, 1
01810 DATA 205, 30, 48, 205, 147, 48, 62, 6, 205, 30
01820 DATA 48, 62, 14, 205, 30, 48, 201, 14, 255, 62
01830 DATA 0, 229, 225, 16, 250, 201
01840 DATA 14, 14, 4, 31, 4, 14, 31, 10, 14, 14, 4, 31, 4, 14, 10, 10
01850 DATA 31, 31, 31, 31, 31, 31, 31, 16, 24, 28, 30, 30, 31, 31, 31
01860 DATA 1, 3, 7, 15, 15, 31, 31, 31, 0, 0, 0, 0, 31, 15, 7, 3
01870 DATA 0, 0, 0, 0, 31, 31, 31, 0, 0, 0, 0, 31, 30, 28, 24
01880 NEXT A
01890 END
    
```

## Finally

Now that you have the physical and electrical connection specified, as well as some driver routines and examples, it should be quite simple to discover some uses for the LCD for your own benefit. As a final thought, the LCD could be connected internally to the Z80 bus, but there are a few restrictions. The Z80 has separate read and write signals, and the enable clock is too fast for the LCD as it is. So in the interest of keeping the Microbee in original condition, I have described this as a port A device.

Note that all programs in this text have been transferred from their appropriate environment, EDASM or BASIC. They haven't been typed in by copying a listing, and each has been verified prior to the transfer. 🐛

## LEVEL

We expect that constructors of an **INTERMEDIATE** level, between beginners and experienced persons, should be able to successfully complete this project.

**SEE 'RETAIL ROUNDUP' FOR A GUIDE TO KIT SUPPLIERS WHO MAY STOCK THIS PROJECT**

## UNIQUE OPPORTUNITY!

Only for readers of Australian Electronics Monthly — here's a unique opportunity to obtain a **6-PEN, A3 'PERSONAL PLOTTER'** at under half cost!

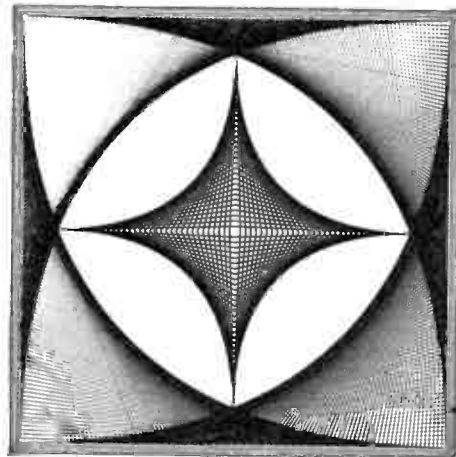
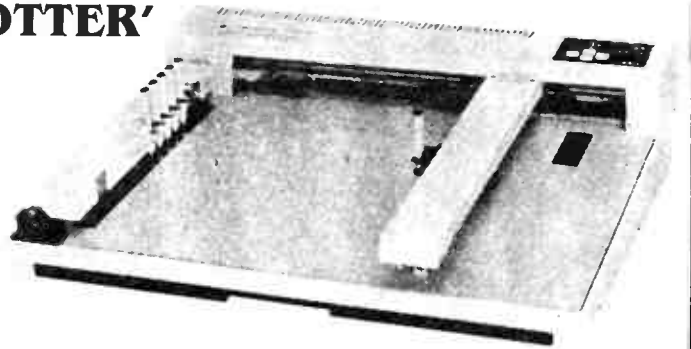
These plotters, made by Iwatsu (model SR6602), were part of a shipment brought into the country for a client who subsequently ceased business before completion of the purchase order. They are brand new and come complete with a handbook, a set of 10 pens and a three-month warranty.

## LIMITED NUMBER ONLY

This is a strictly limited opportunity, as only 30 plotters are available.

### Features:

- 240 V ac operation
- standard RS232 interface (protocol selectable)
- plot area of 270 x 365 mm (A3 sheet)
- plot step of 0.1 mm
- takes commonly available plotter pens
- variable plot speeds — 2 x switch selectable — 6 x software selectable
- ten pens supplied, 0.3 mm diameter tip, four black ink types, six different coloured-ink types.



Simple command parameters permit driving the SR6602 from a terminal or from ASCII strings sent to the serial port of your computer.

## UNBELIEVABLE OFFER:

**\$1299.00!**

(sales tax free)\*

**\$1454.00** inc. sales tax

Delivery to your door, including insurance, is \$20.00.

This offer is made available exclusive to readers of Australian Electronics Monthly through Electronic Facilities of Artarmon NSW and A.E.M. is acting as a clearing house for orders.

## SEND YOUR ORDER NOW!

Only 30 units are available, so hurry before they're all snapped up.

\* All orders claiming sales tax exemption must be accompanied by an appropriate sales tax exemption certificate.

**HOW TO ORDER:** Complete the coupon and send it, together with your cheque, Money Order, or Credit Card details to:

### PLOTTER SPECIAL OFFER

Australian Electronics Monthly PO Box 289, WAHROONGA 2076 NSW

**COUPON** Cut out, or photocopy, and complete this coupon. Send it, together with your cheque, Money Order or Credit Card details to the address above.

- Please make cheques or Money Orders payable to "Australian Electronics Monthly"

Name .....

Address .....

Signature .....

(unsigned orders cannot be accepted)

PLEASE DELIVER: SR6602 Iwatsu plotter(s)

Total cost \$ .....

I enclose payment by:

Money Order  Cheque\*  Amex

Bankcard  Mastercard  Visa

Credit Card No: .....

Expiry Date: .../.../...

Cheque or Money Order No: .....

- If you would like to inspect one of these units, call into our office any weekday during business hours. We're located at: WB Building, Cnr Fox Valley Rd and Kiogle St, Wahroonga NSW. The entrance is in Kiogle St.



# Some New Year speculation

SEEING AS it's the New year, I thought I'd indulge in a little speculation. Remember though, that this is just speculation on my part — Microbee Systems might do something else entirely.

What's might the Microbee of the future look like internally? Perhaps I have already seen it. I hope so.

The Japanese have come up with a new microprocessor chip called the HD64180. It's mostly the good old Z80, the chip used in all current Microbees. But this new one has a few enhancements. The package size has grown from 40 pins to 64, so there's space for, among other things, some more address lines. So, the HD64180 becomes a Z80 that can directly address 512K of memory instead of the 64K the Z80 is limited to.

The chip is based on CMOS technology, meaning its power consumption is very low. It runs the full Z80 set of machine code instructions, as well as a few extras. The most significant of these is the ability to multiply two numbers in hardware (within the chip). The Z80 can only add and subtract and do logical bit shifts, so for it to multiply and divide it has to combine adds and shifts into a software routine.

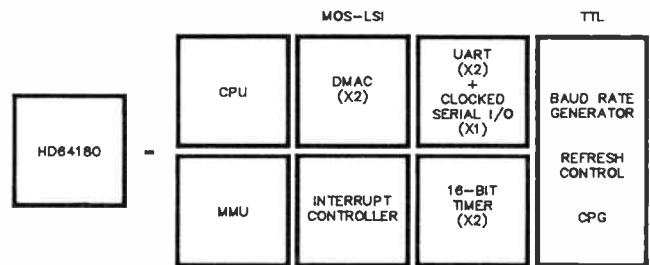
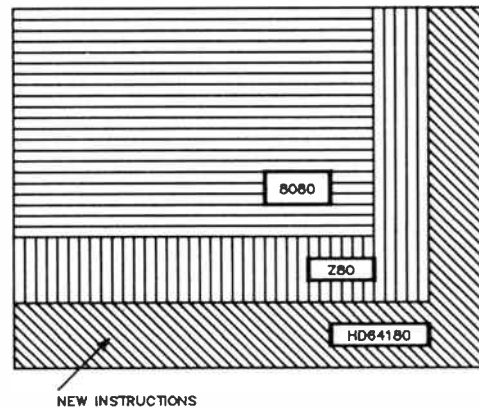
The Microbee has got along fairly well with the Z80. It's ideal for the 32K ROM-based machines, such as the current PC-85 and the disk-based 64K Computer-In-A-Book. But extending beyond 64K of memory is a bit messy, since the Z80 can only address 64K. The 128K Small Business Computer gets around this by switching back and forth between banks of memory, all with the same physical addresses. Like I said, it's messy, but it seems to work. And all of the current Microbees have somewhat limited memory devoted to the screen display. But even with only 3K of screen to play around with, they turn out some quite remarkable graphics by sneaky software manipulation of the 3K.

A recent issue of *Byte* magazine (Sept. '85) featured a kit computer based on the HD64180, and the basic design had Microbee written all over it (not as a kit mind you; been there, done that). This little beauty has 256K of user RAM, as well as 32K of ROM for the boot routines and machine code monitor. There are not one, but two, serial ports and I'd use one for my modem and the other for my printer. There's also a parallel port into which you could plug your Listening Post or whatever.

This little computer has a disk controller which can supervise up to four disk drives in any combination of 3½", 5¼" or 8" formats. The whole computer runs on one single 5 volt power supply, except for a little bit of +12 that's needed for the serial ports, this could make the power supply design super-easy.

As to the operating system, it's good old CP/M, sort of. There's an enhanced version of CP/M used on many Microbees called ZCPR. Well, this new computer runs ZCPR-3, an enhancement of the enhancement of the enhancement! The operating system is written entirely in Z80 code, not 8080 as is the "pure" CP/M, so it takes full advantage of the processor's abilities.

A new Microbee could be designed much along these lines. You could keep the present PCG method of generating graph-



The Hitachi HD64180 is sure to revitalise 8-bit microcomputing with all the features it offers on-board.

ics, so all current software would still run on the new machine. But there should be another graphics mode available, using some of that as yet empty address space: full dot-addressable graphics, the whole screen, the full load! Imagine the applications of that . . . on-screen weather maps and satellite pictures. Digitized photographs. Slow-scan television. Oooh! I want one!

Just for the record, the Australian representative for Hitachi semiconductors is Ellistronics, 797 Springvale Road, Mulgrave, Vic. 3170.

## The too-hard file

For some weeks I have been sharing an office with a new you-beauty Brand-X 16-bit computer with hard disk, heaps of memory, red and white tail fins and benzine supercharger. This device is supposed to be the wave of the future for the electronic office and it would retail for around \$8000. The only trouble is, we're still trying to get it to work.

This machine was bought without a monitor, since we have about half a dozen of them already. Trouble is, the You-Beauty has nowhere to plug one in. There is a nine-pin socket on the video board, and we soon discovered by poking around with an oscilloscope that it has three separate lines carrying horizontal syncs, vertical syncs and video. We soon built a little external circuit to combine these signals into normal "composite video" for our existing monitors. This worked nicely except for one problem. The left hand edge of the picture (about 10 typed characters per line) was missing. Reason: the You-Beauty uses a funny line scanning rate, so it will only work with its own monitor. Result: new monitor. But what's a few hundred dollars between friends?

The You-Beauty arrived with lots of nice software on its hard disk. This we discovered by snooping around with commands like "DIR", even though the first 10 columns on screen or so were missing. Even tried to run the Flight Simulator program on the floppy disk. (It wouldn't go.) Let the machine ▶

# Why buy a toy computer when you can have the real thing for a little more? IBM compatible!

Optional expansion card e.g. A/D converter and DIO

8 slot backplane

8088 processor

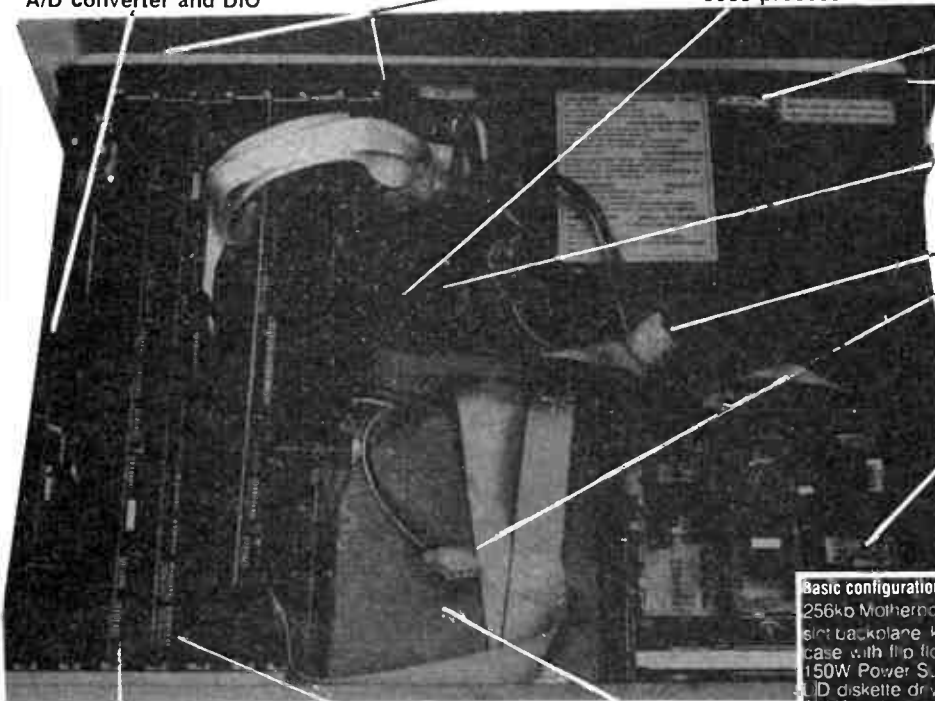
150W power supply

flip top lid for easy access

optional 8087 co-processor

spare power plugs  
F 12V, 5V for your  
experimental set ups

TEAC diskette drive(s)



video interface

multifunction board

optional 20Mb hard disk

**Basic configuration includes**  
256kb Motherboard with 8  
slot backplane keyboard  
case with flip top lid  
150W Power Supply  
1DD diskette drive  
\$1140 ex tax  
\$1295 inc tax

## GUARANTEE

If you can demonstrate, that within 7 days of purchase, any piece of IBM hardware or any commercially available PC-DOS software package except programs that directly call the IBM Basic Roms, that runs on the IBM PC but not on the DATASYSTEM/1, then you may return your DATASYSTEM/1 for a prompt refund.

## DATASYSTEM/1, — the computer that could have been designed just for electronics and computer enthusiasts

The DATASYSTEM/1 is a totally IBM compatible PC, it can run any program, board or peripheral that will run on an IBM PC and we guarantee it. The DATASYSTEM/1 has one extra feature — accessibility — you can get inside the machine easily, you can add extra boards, drives, whatever you want. It's ideal for the enthusiast who doesn't think a computer is a box that crunches numbers. Best of all the DATASYSTEM/1 is quality all through, an excellent keyboard, high quality diskette drives

and superb PC boards with solder masks. Every item is fully tested before it is delivered (by people who know computers,) and best of all it is backed nationally by Science and Computing Application (S.C.A.), one of Australia's leading profession-

al scientific computing specialists. With DATASYSTEM/1 you can run all the programs you can only dream about with the average home computer, such as Flight Simulator, spreadsheets like Lotus 1-2-3 or printed circuit board programs like Smartwork and Autocad. The possibilities are endless! Don't buy a toy when you can have the real machine. Give us a call now.



and superb PC boards with solder masks. Every item is fully tested before it is delivered (by people who know computers,) and best of all it is backed nationally by Science and Computing Application (S.C.A.), one of Australia's leading profession-

### Features of the DATASYSTEM/1

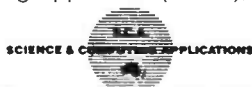
- 8088 processor (4.77 MHz clock)
- optional 8087 co-processor
- fully socketed motherboard
- 8 slot backplane with 256Kb RAM, optional 640k motherboard available
- 150 W power supply
- attractive metal cabinet with lift up lid for easy access (especially practical for laboratory applications)
- High quality IBM-PC style keyboard with indicator LED's
- TEAC double density or quad density diskettes (half height)
- optional 20Mb SEAGATE hard disks (half height)
- colour/graphics and/or monographics (HERCULES compatible) card - available
- fully compatible with IBM-PC hardware and software (runs Flight Simulator)
- multifunction cards available with 384K RAM, parallel and serial ports, battery backed calendar clock, games port
- 12 months guarantee

Options include monitor, 8087 Maths Co-processor, 2nd DD diskette drive, multi-function cards, hard disk drives all at equally low prices, call us for details!

Portable Version also available with same motherboard and built in 9 inch screen — Just \$2100 plus s/t.



N.Z.: S.C.A. (N.Z.) (09) 665 918  
Vic: L.S.A. (03) 419 7400  
Qld: Ballec Systems (07) 369 5900  
S.A.: Microlog Controls (08) 297 2444  
Tas: HST Industries (002) 34 8499  
W.A.: Forth Generation Systems (09) 322 7499



## SCIENCE & COMPUTING APPLICATIONS

Suite 1, 148 Anzac Parade P.O. Box 251, Kensington NSW 2033, Australia

Tel: (02) 662 4255



# WORDSTAR PRINTER PROBLEMS SOLVED

**M**ODERN PRINTERS have dozens of printer commands. Until now it has been impossible to send all of these codes to your printer from a Wordstar file. Most printer demonstrations are written in computer code, not Wordstar.

**FLASHPRINT!!** changes the world of Wordstar and printers. Now you can print anything — even your own special characters or color on a printer with a multi-color ribbon.

And here are special characters which we designed for an Epson and other printers  
 ■ © ☼ → ← ● ✚ ☐ ||| ✚ ● ☐  
 YOU can print compressed proportional elite pica expanded italics quality or any combination your printer allows. Single-key commands control **SUPER** and **SUBSCRIPT** as well as true underline. It's clever.

**FLASHPRINT!!** is supplied with commands for several popular printers. But you can chose the command and the coding your printer needs. **FLASHPRINT!!** does the rest. A single command can send hundreds of codes to the printer (Wordstar allows only four or five).

We include notes on designing your own characters such as boats, cars and graphic symbols.

**FLASHPRINT!!** requires no special knowledge and Wordstar requires absolutely no installation. You simply copy **FLASHPRINT!!** and a printer table on to your normal Wordstar disk and run **FLASHPRINT!!** instead of Wordstar. It loads your table and runs Wordstar.

## NOW WITH FLASHKEY!!

There's more. **FLASHPRINT!!** now includes **FLASHKEY!!** This allows any Wordstar character (including control characters) to be a function. That's 127 function keys on your computer. Functions can contain hundreds of bytes. **FLASHKEY!!** also allows key translation. You can create a Dvorak keyboard or change Wordstar's clumsy commands.

Don't take just our word for it. Here are some genuine unsolicited comments from **FLASHPRINT!!** users:

● If you need any kind of enhancement to Wordstar this is the one. The ads don't do it justice. *First Osborne Group, USA (Foghorn July 1985).* ● Excellent value for such a useful piece of software. *John P. Carney.* ● **FLASHPRINT!!** is everything you said it would be. *Terry Bibo.* ● I had been going to buy Smartkey, but **FLASHKEY!!** will do all the changes I want. *Peter Carnell.*

● It represents the best value for money of any software I have purchased. *Gordon Woolf.* ● Every Wordstar user should have this one. *Kaypro User Group of Victoria.* ● The manual was a pleasant change from many computer-related manuals. *Peter Barker.*

**\$57**

Includes postage and a comprehensive user guide. We can supply almost any CP/M-80 disk format including Apple, Microbee 3.5 inch and 8-inch SSSD.

**FLASHPRINT!!** with **FLASHKEY!!** runs Wordstar versions 2.26, 3.0 and 3.3. An **MS-DOS** version for Wordstar V3.3 which includes enhancements for the IBM PC and clones is now available at \$88.

**JRT SOFTWARE**  
 42 TURNERS AVENUE  
 COROMANDEL VALLEY

SOUTH AUSTRALIA 5051 (08) 278-7076

We believe **FLASHPRINT!!** with **FLASHKEY!!** will completely change the way you use Wordstar.

rest over the weekend. Came back Monday to find it no longer realised it has a hard disk, and claimed drive "C" was illegal.

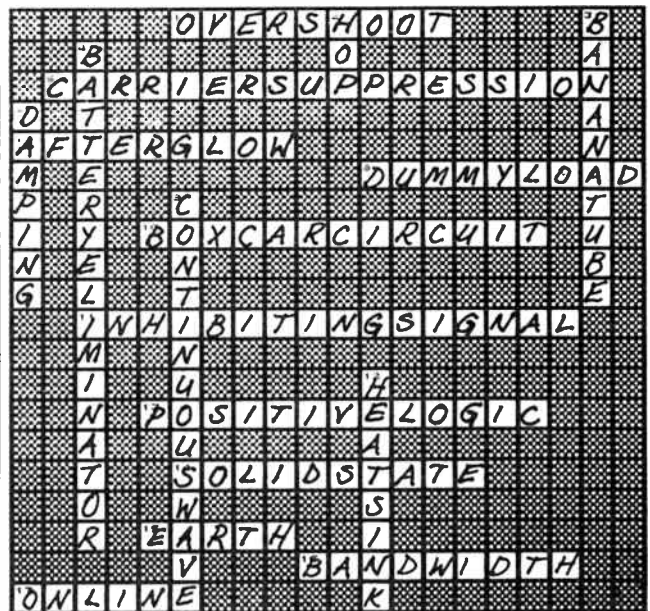
The current theory is that some disk we had in the floppy drive managed to overwrite the operating system on the hard disk, and the only way to fix it is to re-format the hard disk. Goodbye software. I realize that a lot of this is "cockpit trouble" but I don't think our good old Microbee 128K machine would be capable of such devastation, no matter how stupid the operator. So, if Microbee systems are thinking of producing a version of the trendy You-Beauty, I hope they think twice about it. Has anyone really figured out a good use for 16-bit hardware yet?

I would like to welcome my old mate Neil Duncan's new column in this magazine. He's the guy who writes about those other computers, Crapple and Vomitore. Lets see if we can think up some insults to hurl at the users of those machines. I'm sure they can do the same for us.

Seriously, though, I recently spent a week as the Duncan family's house guest during the IREE convention in Melbourne. Even though they are Victorians they do speak reasonable English. Neil seems to know which button to push to make his Apple's screen light up, and he finally has a ham radio rig that works. This is interesting, considering the number of hours I've spent trying to communicate with a collection of snorts, shrieks, and whistles that came from his home-brew rigs. The store-bought one actually produces sounds you can understand.

Plug time: If you know anybody who needs educational software for the Apple, they should contact Neil. He turns out that clever sort of stuff we see from Goodison for the Microbee.

## The answers to last month's Weller Crossword



# ELECTRONIC FACILITIES

## SPECIAL OFFER TO ALL AUSTRALIAN ELECTRONICS MONTHLY READERS.

### A SEMICONDUCTOR SPECIAL.

This pack of selected 74LS IC's is ideal for any hobbyist or professional alike. The pack contains the most common IC's that are used for your designs, projects or servicing.

All IC's in this special offer are top quality NATIONAL PANASONIC brand.

### A ONCE IN A LIFETIME SPECIAL.

#### 5 of Each

- 74LS00
- 74LS02
- 74LS04
- 74LS08
- 74LS10
- 74LS123
- 74LS132
- 74LS138
- 74LS139
- 74LS14
- 74LS164
- 74LS165
- 74LS175
- 74LS20
- 74LS22
- 74LS240
- 74LS244
- 74LS245
- 74LS57A
- 74LS30
- 74LS32
- 74LS373
- 74LS374
- 74LS393
- 74LS74A
- 74LS86

130 IC's FROM NATIONAL PANASONIC.



**ONLY  
\$67.60**  
Plus \$2.50 P&P

Would normally retail about \$140.00

THIS IS AN OFFER THAT YOU CANNOT MISS OUT ON.

PLEASE SEND your mail order to:

**ELECTRONIC FACILITIES** Pty Ltd

PO BOX 351  
Artarmon N.S.W. 2064

67 Dickson Avenue, Artarmon  
Sydney NSW 2064 Australia  
Telephone: 439 3786  
Telex AA177084



MONEY ORDER  CHEQUE

NAME .....

ADDRESS .....

**TOLL FREE (008) 22 6385**

# JAYCAR JANUARY SPECTACULAR SPECIALS!

## SAVE UP TO 70% ON OUR NEW YEAR CLEARANCE

**MAIL ORDER HOTLINE**  
**(02) 747 1888**

Cat. HB 5020  
DIECAST BOX AS USED IN TAUCDI KITS  
**WAS \$11.50 SAVE 43%**  
**NOW \$6.30**

Cat. HB 5006  
4" x 3" x 1" DIE CAST BOX  
**WAS \$8.50 SAVE 53%**  
**NOW \$3.95**

Cat. NA 1020  
MOISTURE REPELLENT SPRAY  
**WAS \$4.95 SAVE 40%**  
**NOW \$2.95**

Cat. CT 2002  
CONE TWEETER  
**WAS \$3.95 SAVE 50%**  
**NOW \$2.00**

Cat. CM 2062  
6" PIONEER MIDRANGE  
**WAS \$12.50 SAVE 52%**  
**NOW \$5.95**

Cat. AC 1600  
TAPE HEAD DEMAGNETISER  
**WAS \$4.95 SAVE 60%**  
**NOW \$2.00**

Cat. AS 3011  
6" WIDERANGE SPEAKER 4 Ohm  
**WAS \$2.95 SAVE 49%**  
**NOW \$1.50**

T199/4A SOFTWARE BOOK PROGRAMS  
Cat. BS 0750 51 EDUCATION PROGRAMS  
**WAS \$27.95 SAVE 50%**  
**NOW \$12.95**

Cat. BS 0752 ENTERTAINMENT/GAMES  
Cat. BS 0754 24 BASIC PROGRAMS  
Cat. BS 0756 BASIC TRICKS  
Cat. BS 0757 GRAPHICS & SOUNDS  
**WERE \$29.95 ea SAVE 50%**  
**NOW \$14.95 ea**

Cat. CX 2615  
3-WAY X-OVER 2kHz, 6kHz  
**WAS \$12.95 SAVE 60%**  
**NOW \$4.95**

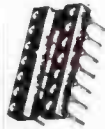
Made in the USA  
HEWLETT PACKARD  
Cat. HP-1103  
PACK OF 100 x 5mm LED MOUNTING CLIPS  
**WAS \$6.50 SAVE 38%**  
**NOW \$4.00**

Cat. HP-9520  
12" SQUARE BLANK DS F/GLASS RB  
**WAS \$9.95 SAVE 50%**  
**NOW \$4.95**  
Cat. HP-9510  
12" SQUARE BLANK SINGLE/S F/GLASS RB  
**WAS \$8.95 SAVE 55%**  
**NOW \$3.95**

240V CANNON MAINS PLUGS  
Cat. PS 1002 AXR-LNE-11B (BLACK)  
**WAS \$9.95 SAVE 70%**  
**NOW \$2.95**  
Cat. PS 1002 XLP-LNE-11C (NATURAL)  
**WAS \$9.95 SAVE 60%**  
**NOW \$3.75**

**AEM 10" 3-WAY  
SPEAKER SYSTEM**  
★ CALL US FIRST ★

MULTILAYER CHIP CERAMICS PACK 100  
Cat. RC-5496 0.01uF  
**WAS \$25.00 SAVE 60%**  
**NOW \$10.00**  
Cat. RC-5495 0.01uF  
**WAS \$25.00 SAVE 68%**  
**NOW \$8.00**



PACK OF 100 IC SOCKETS  
Cat. PI 6482 16 PIN  
**WAS \$25 SAVE 40%**  
**NOW \$15.00**  
Cat. PI 6480 14 PIN  
**WAS \$22.00 SAVE 45%**  
**NOW \$12.00**  
Cat. PI 6484 18 PIN  
**WAS \$28.00 SAVE 43%**  
**NOW \$16.00**



Cat. SL 2700  
MAGGYLAMP  
**WAS \$169 SAVE 15%**  
**NOW \$143.00**

Cat. YX-2900  
240 VOLT NEGATIVE AIR IONISER  
**WAS \$69.95 SAVE 28%**  
**ONLY \$49.95**



Cat. QM-1530  
10A DIGITAL MULTIMETER  
**WAS \$89.95 SAVE 15%**  
**NOW \$76.45**

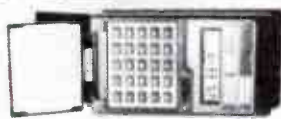


Cat. YT 6505  
ELECTRONIC CALL DIVERTER  
Notre 2 exchange lines are required for  
this appliance  
**WAS \$159 SAVE 15%**  
**NOW \$135.00**



Cat. YS-5035  
RECHARGEABLE NiCad TORCH  
**WAS \$29.99 SAVE 33 1/3%**  
**NOW \$19.99**

Cat. QM 1540  
10A DIGITAL MULTIMETER/CAPACITANCE METER  
**WAS \$129 SAVE 15%**  
**NOW \$109.65**



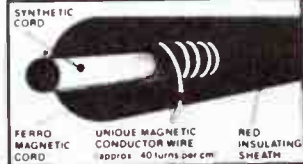
Cat. YT-6500  
ELECTRONIC TELEPHONE DIRECTORY  
**WAS \$59.95 SAVE 33 1/3%**  
**NOW \$39.95**

Cat. MB 3502  
SOLAR BATTERY CHARGER  
**WAS \$16.95 SAVE 26%**  
**NOW \$12.50**



**Our Gore Hill Store  
is open till 4 pm  
Saturdays**

### UNIQUE CONSTRUCTION



### SPARKPLUG LEAD SALE

Because of massive cost increases due to the low Australian dollar we have reluctantly decided to discontinue these French made high-quality leads. We **MAY NOT** have every lead that you require and we obviously cannot back order. To overcome this, we suggest that you allow us to ship the nearest equivalent longer length. This is the chance of a lifetime to get RF suppressed metal plug leads!

RIGHT ANGLE DISTRIBUTOR ENTRY  
30cm cable Cat. WA 5404  
40cm cable Cat. WA 5408  
50cm cable Cat. WA 5412

**WERE \$4.95 SAVE 50%**  
**NOW \$2.47 each**

RIGHT ANGLE DISTRIBUTOR ENTRY  
60cm cable Cat. WA 5416  
70cm cable Cat. WA 5420

**WERE \$5.95 SAVE 50%**  
**NOW \$2.97 each**

STRAIGHT ENTRY  
30cm cable Cat. WA 5434  
40cm cable Cat. WA 5438  
50cm cable Cat. WA 5442

**WERE \$4.95 SAVE 50%**  
**NOW \$2.47 each**

STRAIGHT ENTRY  
60cm cable Cat. WA 5448  
70cm cable Cat. WA 5452  
80cm cable Cat. WA 5456  
90cm cable Cat. WA 5460

**WERE \$5.95 SAVE 50%**  
**NOW \$2.97 each**

COIL TO DISTRIBUTOR STRAIGHT  
30cm cable Cat. WA 5474  
40cm cable Cat. WA 5478

**WERE \$4.95 SAVE 50%**  
**NOW \$2.47 each**

COIL TO DISTRIBUTOR STRAIGHT  
60cm cable Cat. WA 5482

**WAS \$5.95 SAVE 50%**  
**NOW \$2.97**

### GREEN STICKER BOOK SALE

All books in our shops that have a green sticker signify that you can take **50%** off of that particular book.

### PERSONAL SHOPPERS CALL IN AND BROWSE

### MAIL ORDER CUSTOMERS

Any mail order customer who purchases during January or February will get a **RED STICKER** list of books. This will show even greater book savings!

Cat. XC-0112  
TRADITIONAL MECHANICAL TRAVEL CLOCK  
**WAS \$12.95 SAVE 25%**  
**NOW \$9.95**

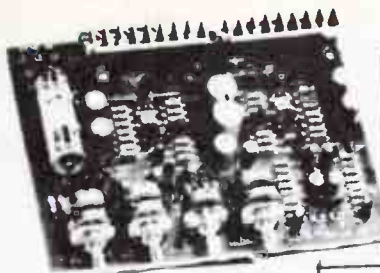




**MINIMUM 15% OFF EVERYTHING**

**-SAVE UP TO 70%!**

**SORRY! NO Backorders. Sale only applies to goods IN STOCK during sale**



Cat AA-0300  
30+30 WATT STEREO AMP  
INCLUDING PRE AMP  
★ Fully built and tested  
★ Separate bass, treble, balance and volume controls  
★ Less than 0.1% distortion  
★ Mic, phono and aux inputs (line)  
★ Power supply components on board  
★ Just connect a transformer, speakers, a signal

**WAS \$49.95 SAVE 15%  
NOW \$42.45**

ABS PLASTIC CONSOLE BOXES WITH ALUMINIUM LID  
215(w) x 130(d) x 47(h) x 73(hr)mm  
Cat HB-6210 - ORANGE  
Cat HB-6211 - GREY  
Cat HB-6212 - BLUE  
**WERE \$16.25 SAVE 50%  
NOW \$7.95 EACH**

**BLUE COLLAR WORKER BRIEFCASE**

This great new Australian made metal parts/tools carry case is suitable for just about all tradesmen. From plumbers, electricians, carpenters to security technicians, builders and electronic servicemen. Advantages include easy storage, easy handling - each compartment seals tight when closed. One long compartment for tools. Rack available soon for mounting 2 units in a vehicle. Quality powder coated green enamel.  
Size 362 x 365 x 80mm  
Cat TB-2000

**ONLY \$49.50  
WILL LAST FOREVER!**



Cat M5-4010  
SQUEEKY CLEAN MAINS FILTER x4  
**WAS \$125 SAVE 15%  
NOW \$106.25**

Cat M5-4102  
SQUEEKY CLEAN MAINS FILTER x1  
**WAS \$39.50 SAVE 25%  
NOW \$29.00**



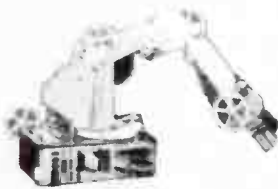
Cat XE-4950  
UV EPROM ERASER  
**WAS \$99.50 SAVE 20%  
NOW \$79.50**



**GREAT SPECIALS!**

**NEW Low cost Robot Kit**

Ref EA January 1986  
This is a true 5-axis pick and place robot with substantial payload capability that you can connect direct to your PC! But the best feature is THE PRICE! You can build the mechanical kit which includes motors, bearings, arm components, pulleys etc for just \$189! The full construction manual is just \$10 extra. The motor drive electronics, computer interface and power supply are also available.  
COMPLETE MECHANICAL ROBOT KIT Cat KA 1625  
**ONLY \$189.00**  
COMPLETE CONSTRUCTION MANUAL Cat BI-8015  
**ONLY \$10.00**



**NEW Mini FM Transmitter**

Ref ETI  
Great stable and compact FM transmitter Tiny!  
Cat KE 4711  
**ONLY \$8.95**



**NEW AM-STEREO/FM-STEREO WIDE BAND TUNER**

Ref EA Dec/Jan onwards  
What can I say - it's a world beater. If you want THE BEST at any price. We will not have the kit in stock in January (due to metalwork delays over Xmas) but it should be available mid and Feb.  
Cat KA 1635 INTRODUCTORY PRICE  
**\$599 COMPLETE**



**"PEST OFF" Ultrasonic Pest Repeller**

Ref EA November 1985  
A mozzie season special. See November EA for more info.  
Cat KA 1620  
**ONLY \$39.95**



**NEW 145 Watt Mosfet Amp**

Ref EA October 1985  
This is the high power mono Mosfet amp version of the Playmaster 200. The shortform amp kit includes all parts except the heatsink extrusion/bracket which is available separately.  
Cat KA 1622  
**ONLY \$89.50**

**NEW CD Attenuator**

Ref EA January 1986  
This project enables you to dub from a compact disc to a cassette without overloading. It attenuates the signal to accommodate the smaller dynamic range of the cassette medium. Kit includes case.  
Cat KA 1624  
**ONLY \$7.95**

**Jaycar ELECTRONICS**

Incorporating ELECTRONIC AGENCIES  
Carlingford Hurstville Gore Hill Brisbane Mon-Fri 9am - 5:30pm  
Sydney and Concord Mon-Fri 8:30am - 5:30pm  
Sydney Carlingford Hurstville Thursday nights until 8:30pm  
Brisbane Thursday night until 8pm  
Sydney Carlingford Hurstville Brisbane Saturdays 9am - 12 noon  
Gore Hill Saturday 9am - 4pm

CONCORD NOT OPEN ON SATURDAYS

**NUMBER 1 FOR KITS**

**S.W. SHOWROOMS**

**UTTERSWANG MAIL ORDERS HEAD OFFICE**

**SYDNEY** 117 York Street Tel (02) 267 1614  
**CARLINGFORD** Cnr Carlingford & Pennant Hills Road Tel (02) 872 4444  
**CONCORD** 115/117 Parramatta Road Tel (02) 745 3077  
**HURSTVILLE** 121 Forest Road Tel (02) 570 7000  
**GORE HILL** 188/192 Pacific Highway (Cnr Bellevue Avenue) Tel (02) 439 4799

**BRAND** 144 Logan Road Tel (07) 393 0777  
P.O. Box 185, CONCORD 2137  
115-117 Parramatta Road, CONCORD 2137  
Tel (02) 747 2022 Telex 72293

**POST & PACKING**

\$5	\$9.99	\$2.00
\$10	\$24.99	\$3.75
\$25	\$49.99	\$4.50
\$50	\$99.99	\$6.50
\$100	\$198	\$8.00
Over:	\$199	\$10.00

CONCORD ROAD FREIGHT ANYWHERE IN AUSTRALIA ONLY \$13.50



**MAIL ORDER VIA YOUR PHONE**

## AWA switches to 'local' mobile radio production

In a bid to win additional government contracts, AWA has transferred the manufacturing of its RT-85 mobile radio from Japan to its New Zealand based company, AWA New Zealand Limited.

Under the recent "Australia/New Zealand Closer Economic Relations Trade Agreement", which allows for reciprocal manufacturing advantages, New Zealand manufactured communications equipment is considered "locally" made by Commonwealth and State Government departments.

Mr Greg Hughes, General Manager of AWA's Ashfield Division, said, "Local manufacture of the RT-85 Carphone will position AWA to effect increased penetration into these government departments, as we are now able to satisfy their long-standing preference for locally made and serviced products.

"This AWA microprocessor controlled VHF/UHF FM two-way land and mobile radio undergoes the same stringent quality control procedures in New Zealand as it did in Japan."

The 64 channel capacity

VHF/UHF mobile radio comprises a simple push button digital display control unit with attached lightweight microphone, a sealed, rugged diecast transmitter/receiver and a tailored speech frequency response high efficiency loudspeaker.

Designed specifically to overcome the space and mounting limitations of modern vehicles, the RT-85's control head mounts conveniently near the driver while the transmitter/receiver mounts in a sturdy cradle under the dashboard or in the boot.

AWA's RT-85 Carphone also has a wide range of options that expand the capabilities of the system, allowing for future operational requirements such as automatic number identification, selective calling and status.

"Sophisticated options such as these are essential to services such as public utilities, metropolitan and bush fire



Don Jamison of AWA (left) and Brian Chapman of AGL with the first NZ-made RT-85 mobile.

brigades, police and police rescue squads and ambulance services," said Mr Hughes.

AWA has been consistently involved in the mobile radio communications field since 1922 and supplied the radio communications needs of many large and small organisations throughout Australia and overseas.

As an example, the company has recently been awarded a contract to supply the Australian Gas Light Company with 260 RT-85 Carphones for their customer service fleet and for their emergency gas maintenance services.

## RTTY/CW computer interface



A computer interface designed to connect to a radio transmitter or receiver and allow computerised RTTY/ASCII/AMTOR/ARQ/FEC/CW operation is available from GFS Electronic Imports.

Known as the Model MFJ-1224, and manufactured in the USA by MFJ Enterprises of Mississippi, it offers a number of unique features, claim GFS. For example, it may be used on most of the common computers about today due to its versatile I/O circuitry. Such machines in-

clude the VIC-20, C-64, Apple and TRS-80C. Included in the unit's price is a CW/RTTY software cassette to suit the VIC-20/C-64 computers.

The MFJ-1224's design makes use of a sharp 8-pole active filter when in the 170 Hz shift or CW modes. GFS claim that this, coupled with its XR2211 PLL detector, provides good copy from almost unreadable signals. It is capable of operating on 850 Hz and 425 Hz as well as the 170 Hz shifts.

Operation on AMTOR, ARQ

and FEC are accommodated provided the host computer has the appropriate software. A single dc power source of 12 to 15 volts is all that is required for operation.

Price of the MFJ-1224 is \$345 plus \$14 P&P. For further information contact GFS Electronic Imports, 17 McKeon Road, Mitcham 3132 Vic. (03) 873 3777.

### GFS/AEM 'WIN A SCANNER' CONTEST RESULTS

This contest, which ran over the July to September 1985 issues, proved quite popular. It was very difficult judging the winner, but

**John Bailey of Surrey Hills, Vic.**

pulled it off. Congratulations, John. Thanks to all those who entered. Answers and more details next month.

### 6UP POTPOURRI ISSUE



The quarterly magazine dedicated to amateurs interested in the VHF/UHF bands, six metres and up. Vol. 5 (1985-86) now commencing. **SUBSCRIBE NOW!**

6UP is dedicated to publishing solid, practical information, news and reviews for radio amateurs who frequent the VHF and UHF bands. Vol. 4 (1984-85) included articles on — Component Considerations at VHF/UHF, Meteor Scatter, Experimental 2m converter Using GaAsFETs, Sporadic-E Propagation, Packet Radio Experiments on Six Metres, Care & Feeding of RF Power Transistors, Coaxial Collinear Antennas, the EME Path, Working the Shuttle, a 5-Over-5 for Six, etc. Vol. 5 promises more of the same!

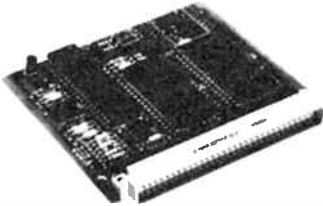
It costs just \$20 per year for four issues packed with info.

Compiled and published by Roger Harrison VK2ZTB and Andrew Kay VK2YLA.

Send subscriptions to:

**Teknidata Pty Ltd  
PO Box 844  
North Sydney 2060 NSW**

**Rockwell  
MODEMS**



Superior Performance at an affordable price CCITT

R1212-1200 BPS FDX      R48 -4800 BPS HDX  
R2424-2000 BPS FDX      R96 -9600 BPS HDX

Device Sets Avail. Quantity Orders.



73 Eric Street Goodna Qld 4300  
PO Box 6502 Goodna Qld 4300  
Phone (07) 288 2455 Telex AA43778 ENECON  
New Zealand Office  
Phone (4) 72 6462 Telex NZ30135 AUDITOR

**HAPPY  
NEW YEAR**

**Hypac Electronics will be closed between 24/12/85 till the 13/1/86.**

The reason, we're all heading overseas to search out more top quality products at the best prices in town.

So look to our advert in the March issue of Australian Electronics Monthly, and save your money for the top specials we will have in March.

I would like to thank you for your support in 1985.

Best Wishes  
Colin Mead and Staff.

MAIL ORDER Hot Line 02 808 3050  
**HYPEC ELECTRONICS  
PTY. LTD.**

21 Ryedale Road, West Ryde  
NSW 2114. PO Box 438 Ryde,  
NSW 2112. Telex: AA71551

**PROGRAMMABLE  
POCKET  
SCANNER**

**-MICROCOMM-  
SX-155**

**PROFESSIONAL  
POCKET SCANNER  
WITH OVER 16,000  
CHANNELS & 160  
MEMORIES**

**26  
to  
32,  
68  
to  
88,  
138  
to  
176  
and  
380  
to  
514  
MHz**



The Microcomm SX 155 represents the latest developments in State-of-the-art LSI CMOS technology as applied to scanning monitor receivers. It incorporates many features, a lot of which are not even found in today's larger base scanners

For example the SX 155 has 160 memory channels which can be programmed in either of two modes. The first allows you to manually program the entire 160 channels. The second mode provides for manual programming of the first 40 channels with the top 120 reserved for use by the SX 155 while in its SEARCH mode. It uses these channels to automatically store frequencies on which it has found signals during the search phase

The SX 155 also features a Priority Channel (for that important frequency) An LCD display providing readout of all receiver functions including an accurate crystal controlled 24 hour clock

Supplied complete with rechargeable Nicad batteries, charger, and rubber duck antenna, the SX 155 is a must for anybody with an interest in monitoring.

**PRICE \$449  
+ \$14 P & P**

AUSTRALIAN DISTRIBUTOR  
**GFS ELECTRONIC IMPORTS**  
Division of DERIBAR PTY LTD

17 McKeon Road, Mitcham, Vic. 3132  
PO Box 97, Mitcham, Vic. 3132  
Telex: AA 38053 GFS  
Phone: (03) 873 3777 3 Lines

*Cop This!*

**I.C. SPECIALS  
FROM  
Promark**

**SIEMENS  
IC SPECIALS**

TCA 785 PHASE CONTROLLER	7.55
TCA 965 WINDOW DISC.	4.55
TCA 205A PROXIMITY DET.	4.85
TCA 2365 DUAL POWER AMP.	7.85
TDA 1046 AM RECEIVER	8.95
TDA 1047 FM IF + DEMOD.	6.15
TLE 3101 PHASE CONTROLLER	4.75
TDA 4700 SMPS DRIVER	15.60
TDA 4718 SMPS DRIVER	11.70
S 469 FM RECEIVER	8.50
S 576A TOUCH DIMMER	8.50
S 041p FM IF AMP.	2.85
S 042p VHF MIXER/OSC.	3.55
SAB 0600 3 TONE CHIME	8.85
SAB 0529 TIMER	7.75
SAE 0700 TONE GEN.	4.85
UAA 170 LED DRIVER-SPOT	5.00
UAA 180 LED DRIVER-BAR	5.00
SAB 80535 MICRO CONTROLLER	38.00

ALL PRICES PLUS TAX 20% \$4.00  
FREIGHT. MIN ORDER \$50.00 BEFORE  
TAX AND FREIGHT.

EX-STOCK EX-STOCK

**Promark  
Electronics** PTY. LTD.  
(INC. N.S.W.)

SYDNEY 02-439 6477      MELBOURNE 03-878 1255      TOLL FREE 008-22 8226

Insert X803 on Information Feedback Card      WORKS 694

# UHF CBers — boost your signal with this beam antenna

## Garry Crapp

Technical Products Department  
Dick Smith Electronics

This simple to construct beam antenna comes as a kit and will boost your signal by a factor of around 18 times. Make your four watt signal sound like 70 watts!

THE RANGE you can reliably achieve on the 477 MHz UHF Citizens Band is entirely determined by what is called 'station system performance'. A station system comprises:

- 1) the antenna
- 2) the feedline
- 3) the receiver, and
- 4) the transmitter

The height of the antenna above the 'average terrain' also matters. This means that, either you live on top of the biggest hill around, or you put up a big tower to get the same advantage! The transceiver you buy or own will have a given level of performance, so that's more or less fixed. However, the antenna and feedline parts of the station system provide a wide latitude for obtaining improved station system performance.

Omnidirectional antennas (that transmit and receive equally in all directions of the compass) are widely used on the UHF CB band. Such types range from the humble ground-plane to 'high gain' collinears. An omnidirectional antenna which exhibits some gain will give better range and improved signal strengths compared to a groundplane type.

A beam antenna will also give improved range and signal strengths in its favoured direction, and at the same time reduce the possibilities of interference from (or to) directions it does not favour, which an omnidirectional antenna will not.

However, a beam antenna needs to be 'aimed' in the desired direction. For this purpose, a wide range of antenna rotators are available, either designed for aiming TV antennas or for radio amateur use.

## Design details

The antenna described here is a Yagi type, named after one of its co-inventors, Hidetsu Yagi. The Yagi antenna is a popular type because it gives the most gain for the least amount of materials used in construction. Or, as the Americans put it, "... best bang for the buck."

A Yagi comprises a dipole driven element, a reflector behind it, and one or more directors in front of it, as shown in Figure 1. It receives and transmits best as shown by the direction of the arrow in front. In actual fact, it will work,

to some extent, in all directions, but best over a range of directions in front of the antenna, as illustrated in Figure 2.

The close-spaced lines show the area over which it gathers more energy on reception or where it sends more energy when transmitting. Note that, to the side of the antenna, the lines are widely spaced and to the rear they are a little more closely spaced. This shows that very much less energy is received or transmitted off the sides of the antenna and little is received or transmitted to the rear, but nowhere near as much as to the front. Figure 2 looks "down" on the antenna. If you looked from the side, the diagram would be similar.

If you draw a diagram of signal strength from all directions around the antenna looking, say, top down, you get something like Figure 3. In front of the antenna is the main lobe. Where the signal strength falls to 'half power' either side of the forward direction determines the antenna's beamwidth. For a Yagi it will be different when looking 'top down' to looking 'side on', so two beamwidths are generally quoted in such antenna specifications. Figure 4 illustrates the side-on view.

The ratio of the signal strength in the forward direction to the signal strength in the rearward direction is called the front-to-back ratio. The ratio is conveniently expressed in decibels (dB).

The advantage a beam antenna gives you is called its gain. The gain is always expressed as a ratio compared to either a theoretical antenna (i.e. convenient, but impossible to make!) called an isotropic antenna, or a dipole (which is a practical antenna), and expressed in decibels (dB). An isotropic antenna radiates or receives equally well in *all* directions. Gain quoted with respect to such an antenna is written "dBi", while gain with respect to a dipole is written "dBd". If the reference antenna is not quoted — don't believe the gain figure! Incidentally, a dipole has gain compared to an isotropic antenna. Hence dBi gain figures are always higher than dBd figures.

In a Yagi antenna, the reflector is a few per cent longer than the driven element, while the directors are a few per cent shorter than the driven element. The driven element is a half wavelength dipole. The directors may be of varying lengths or all the same length. Also, the director spacings may vary, or may be constant, the first director being a different distance from the driven element.

The first major requirement of this design was simplicity of construction. To this end, a simple spacing scheme was settled on and the antenna designed around that criterion. A manageable beam size of about one and a half metres was decided on and this resulted in a beam with a total of 13 elements, allowing some 245 mm of boom behind the reflector for mounting. The reflector to driven element spacing and driven element to first director spacing is the same, being 125 mm. The spacing between directors is constant, being 100 mm centre-to-centre. All the directors are the same length — 258 mm. Figure 5 gives all the mechanical details.

All elements, except the dipole driven element, are cut from commonly available aluminium strip 10 mm wide by 3 mm

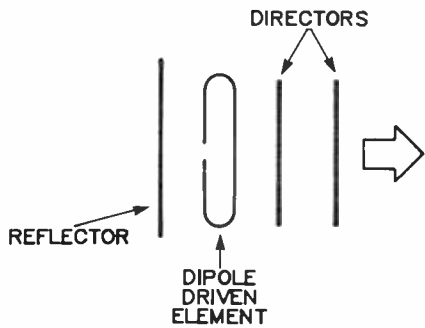


Figure 1. The general form of a Yagi antenna. The driven element is a dipole a half wavelength long at the design frequency. The reflector is a few per cent longer than the driven element, while the directors are shorter. The reflector is spaced about one-fifth to one-quarter of a wavelength behind the driven element. The directors are spaced between about one-tenth and one-fifth of a wavelength apart and the first director may be quite close to the driven element. It transmits and receives best in the direction of the arrow.

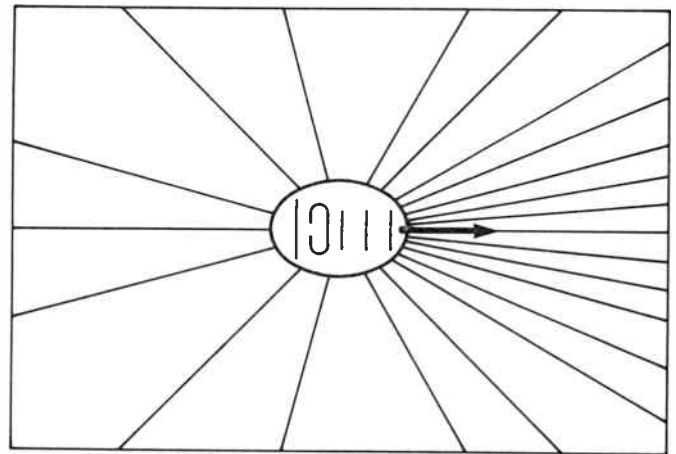


Figure 2. The antenna will receive (and transmit) signals in all directions, but better in some directions than others. The close-spaced lines show where more energy is gathered when receiving or more energy is concentrated when transmitting.

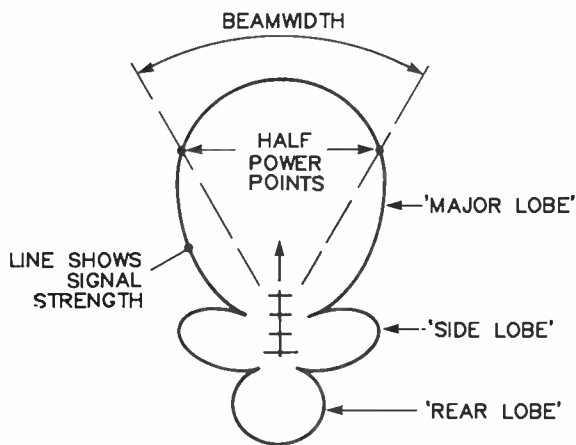


Figure 3. This shows the typical 'radiation pattern' of a beam. The distance from the antenna to the line is a measure of signal strength (radiated or received). This is a top-down view of the antenna. Note the various 'lobes' and how very little is received or radiated from the sides of the antenna. This view of a yagi is generally known as the electric plane, or 'E-plane', view.

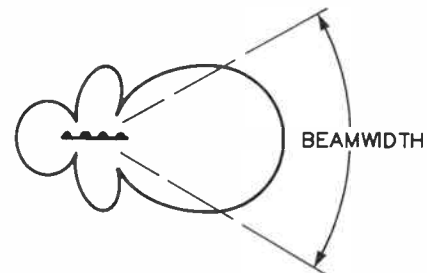


Figure 4. This shows the typical 'side-on' radiation pattern of a beam. Note the similarities to Figure 3. This view of a Yagi is generally known as the magnetic plane, or 'H-plane', view.

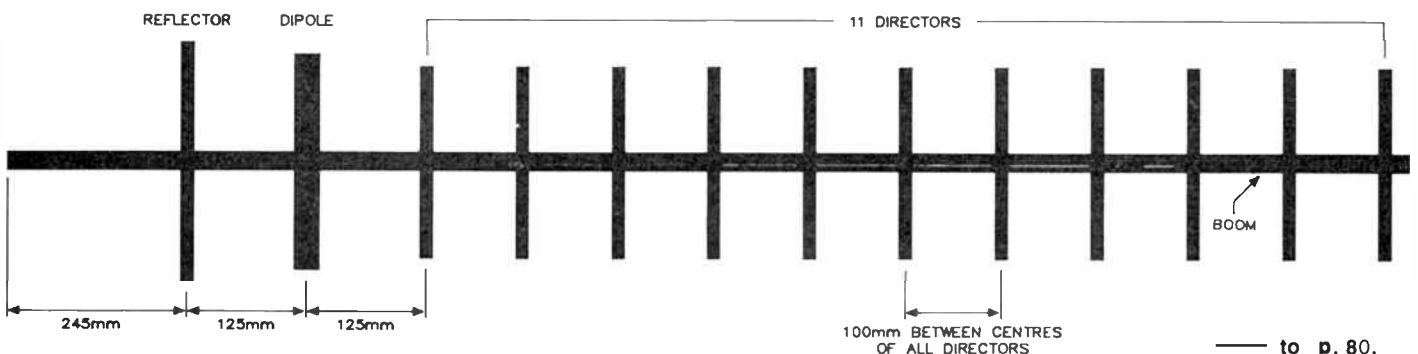


Figure 5. Overall assembly details and general dimensions of the project.

NOTE: DIPOLE, PC BOARD DSE ZA1898  
 REFLECTOR—10x3x310mm ALUMINIUM STRIP—1 OFF  
 DIRECTORS—10x3x258mm ALUMINIUM STRIPS—11 OFF  
 BOOM—19x19x1500mm SQUARE SECTION ALUMINIUM

— to p. 80.

# ALL ELECTRONIC COMPONENTS

118 - 122 LONSDALE STREET, MELBOURNE, VIC. 3000, Australia Telephone 662 3506

**Over 25 years of mail order service — right in the heart of the city!!**

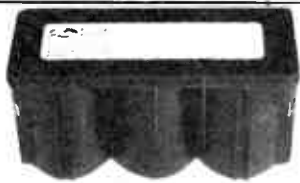
As well as our well known and respected over the counter service, we feature extensive mail order facilities. Export orders are no problem — as our New Zealand, Greek, and Cocos Keeling Island customers have found! These orders are quoted free of Sales Tax, and are despatched promptly and efficiently.

*As double protection against orders going astray, parcels are sent either via Certified Mail, or insured, Security Post Air Mail.*

**SAMPLE GOOD-OLD-FASHIONED SERVICE AND QUALITY COMPONENTS, ALL ELECTRONIC COMPONENTS ARE AUSTRALIA'S LARGEST KITSET STOCKISTS, AND EVEN STOCK MOST EA, ETI, HE and AEM PRINTED CIRCUIT BOARDS BACK TO 1967!!**

**WE ARE NOT A "FLY-BY-NIGHT" MAIL ORDER COMPANY — WE STAND BY ALL OUR PRODUCTS AND OFFER FULL MANUFACTURERS WARRANTY. AS OUR NAME SUGGESTS, WE STOCK A HUGE RANGE OF COMPONENTS, AND CAN QUOTE ON JUST ABOUT ANYTHING ELECTRONIC!**

**HAVE A LOOK AT THESE BARGAINS:**



**GATES!! TRULY SEALED, LEAD ACID, MAINTENANCE FREE BATTERY!!**

- \* MIL SPEC
- \* 1200 DAY STORAGE
- \* 5 OR 2.5 AH @ 6V
- \* 360 INSTANTANEOUS SURGE AMPS
- \* 8 YEAR FLOAT LIFE
- \* BUILT IN RELIEF VALVES
- \* 200-2000 RECHARGES
- \* CAN BE DISCHARGED TO 0.8 VOLTS
- \$40.00 ea incl tax.

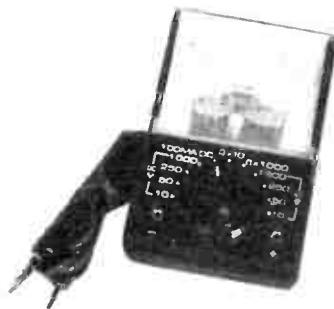


- NOT SLEEVE BEARING
- NOT BUSH BEARING
- NOT ROLLER BEARING BUT GENUINE BALL BEARING WITH STRONG DIE CAST FRAME
- \$37.50 incl tax
- 88 mm or 75 mm
- Guards and cords also available



**DELUXE UNIVERSAL NI CAD BATTERY CHARGER AND METER TESTER**

- \* Tests batteries
- \* "SAVES" standard batteries
- \* Accepts all standard sizes
- \* Full instructions
- \* Approved
- \$26.50 inc tax



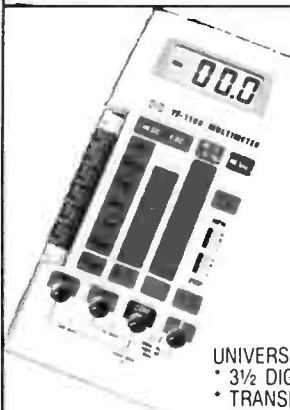
- SIMPLE MULTIMETER**
- \* 2000 Ω/V
  - \* USES ONE "AA" BATTERY
  - \* MIRRORED SCALE ONLY \$14.50 inc tax



- UNIVERSITY MVA20**
- \* 20 kΩ/V — DC
  - \* 8 kΩ/V — AC
  - \* FUSE & DIODE PROTECTED
  - \* 10 AMP DC \$47.05 inc tax



- UNIVERSITY MVA 22**
- \* SAME AS MVA 20 BUT ALSO HAS 10 AMP AC RANGE \$49.75 inc tax



- UNIVERSITY YF1100**
- \* 3½ DIGIT LCD
  - \* TRANSISTOR TESTER
  - \* HAND HELD c/w STAND
  - \* 10 AMP DC \$94.00 inc tax



- MX 331 — AMERICAN QUALITY**
- \* ± 0.1% BASIC ACCURACY
  - \* 10 AMP AC/DC
  - \* DIODE TESTER
  - \* 3½ DIGIT LCD
  - \* AUTO DECIMAL POINT \$265.00 inc tax
- LIMITED STOCK



- ETI 142 NO HOLDS BARRED POWER SUPPLY**
- \* 0-30 VOLTS
  - \* 0-15 AMPS
  - \* FULLY PROTECTED
  - \* THE BIGGEST YET
  - \$323.38

We at ALL ELECTRONIC COMPONENTS have earned our reputation through honest, reliable trading, and treat all orders with enthusiasm and care — even down to Certified packing and post. Why not TRY and SEE!



**KITSETS GALORE — HERE'S A COUPLE**

**WOULDN'T IT BE BEAUT TO STRIKE GOLD ON YOUR HOLIDAYS!**

- 4 MODES
- VLF/TR DESIGN
- PRE-WOUND COIL
- GROUND BALANCE etc

**\$264.51**

**AEM 4600 DUAL-SPEED MODEM**

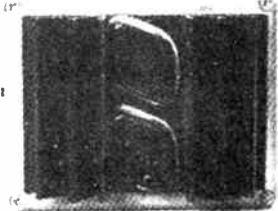
- 300/300 BAUD
- 1200/75 BAUD
- COVERS MAJORITY OF POPULAR APPLICATIONS




**SICK OF REPLACING POINTS REGULARLY? ETI 316 TRANSISTOR ASSISTED IGNITION**

- Saves Points
- Reduces Consumption
- Can change back to original system

**\$35.00**



**EA TRANSISTOR ASSISTED IGNITION**

- SAVES POINTS
- REDUCES CONSUMPTION
- DIE-CAST CASE
- SIMPLE!!

**\$38.51**  
OPTO-ELECTRONIC ADD-ON ONLY  
**\$20.29**

**NOT ONLY DO WE STOCK KIT BOARDS AND PANELS, BUT WE CAN FILL YOUR REQUIREMENTS FOR INDUSTRIAL BOARDS, PANELS, PLATED-THROUGH HOLE BOARDS, MEMBRANE SWITCHES etc . . . WE ARE ONLY LIMITED BY YOUR IMAGINATION!!**

Local customers — Ask our Rep to call to discuss your needs. Ph: 662 1381

**MAIL ORDER SPECIAL OFFER**

Order 1 or 100 items, just add \$5.00 to total order to cover handling and delivery costs.

**PLEASE PRINT**

Please supply me with the following items:

	QTY	TOTAL COST
GATES BATTERY (size)	\$40.00	
EP88 COMPUTER FAN	\$37.50	
WY108 BATTERY CHARGER	\$26.50	
SIMPLE MULTIMETER	\$14.50	
MVA 20	\$47.05	
MVA 22	\$49.75	
YF 1100	\$94.00	
MX331	\$265.00	
ETI 142 KITSET	\$323.38	
ETI 1500 KITSET	\$264.51	
ETI 316 KITSET	\$35.00	
EA TAI KITSET	\$38.51	
EA OPTO ADD-ON KITSET	\$20.29	

SUBTOTAL \_\_\_\_\_  
 POST/PACK \$5.00 \_\_\_\_\_  
 TOTAL \_\_\_\_\_

Name .....

Address .....

Town/State ..... Postcode .....

**PERSONAL SHOPPERS MOST WELCOME**  
 Building kitsets saves \$\$\$ on commercial units — you don't pay for the labour!!

- Importers
- General Sales
- Radio Equipment
- Microwave Equipment
- Radar Equipment
- Pulse Techniques
- Industrial Electronics
- Instrumentation

# aem star project

thick. The boom is a length of 19 x 19 mm square-section aluminium tubing. The elements, except the dipole, are all secured to the boom with PK screws. The kit comes with all the elements and the boom pre-drilled.

The driven element is quite cunning in its design. To 'match' 50 ohm cable to the dipole, we have employed a "gamma match". Its form is shown in Figure 6. This form of matching is quite commonly used on lower frequency antennas. The impedance at the centre of a dipole driven element in a Yagi is quite low. The 'gamma arm' is 'tapped' out along one side of the dipole to a point that gives a match the 50 ohms of the coaxial cable feedline. However, this 'arm' adds a little inductance in series, so a small capacitor is used to 'tune out' this inductance.

The problem is, at UHF, the addition of the matching paraphernalia unbalances the dipole driven element and the beam does not perform properly. The solution is to shorten that arm of the dipole to which the gamma match is attached.

The dipole driven element here is constructed from double-sided, fibreglass substrate printed circuit board. A disc at the end of the gamma match arm forms the required capacitance with a disc on the opposite side of the pc board and the inner conductor of the coax feedline connects to this. Figure 7 illustrates.

This month's ★ Star Project ★ is from Dick Smith Electronics who will be marketing kits through their stores and dealers; cat. no. K6304, \$39.95. Mail order enquiries to PO Box 321, North Ryde 2113 NSW. (92) 888 3200.

## AUTHOR! AUTHOR!

So you've written this *great* article.

Tell us all about it then!

Maybe you've developed a project you think others might be interested in?

We'd like to hear from you!

Perhaps you'd just like to write in and comment on the magazine, tell us what you think of it and what you'd like to see us doing.

We're only too happy to hear from you!

(All bouquets gratefully accepted, brickbats next door, please!)

Write to:

Roger Harrison  
Australian Electronics Monthly  
PO Box 289  
WAHROONGA 2076 NSW

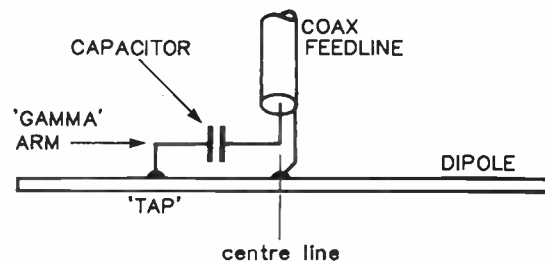


Figure 6. A 'gamma match'. The tap provides an impedance match to the coaxial cable, but the gamma arm introduces a small inductance. This is tuned-out by the capacitor.

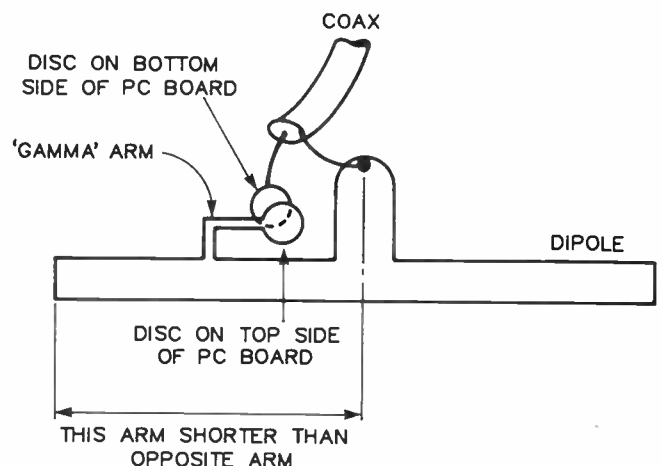


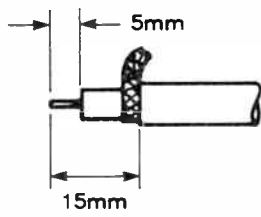
Figure 7. General view of the driven element. The effect of the gamma match on the operation of the dipole is compensated for by shortening that side of the dipole.

## Assembling the beam

Assembly of the beam is quite straightforward as the elements and boom come pre-drilled. No measuring, cutting or drilling is required! First, identify all the directors and the reflector. The reflector will be the longest 10 x 3 mm aluminium strip. The 11 directors are all the same length. Determine which end of the boom is which. The reflector is mounted about 245 mm from one end, the leading director is right at one end. Screw the reflector and all the directors to the boom using PK screws.

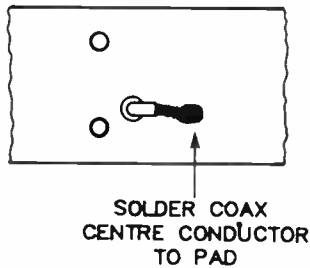
To assemble the dipole driven element, a short length of 6.5 mm diameter coax needs to be attached. This should be a high quality, relatively low loss type, such as RG223/U. You'll need only 200-300 mm. The other end should be terminated in a suitable connector, such as a BNC type. Figure 8 shows how it's done. To prepare the cable, expose about 12-15 mm of the inner conductor and insulation. Undo the braid, twist it around and lay it to one side. Don't leave any stray braid wires hanging around loose. The centre conductor passes through the hole adjacent to the pad at the end of the gamma arm and is soldered to the lone pad on the underside of the board.





CABLE PREPARATION

UNDERSIDE OF DRIVEN ELEMENT



SOLDER COAX CENTRE CONDUCTOR TO PAD

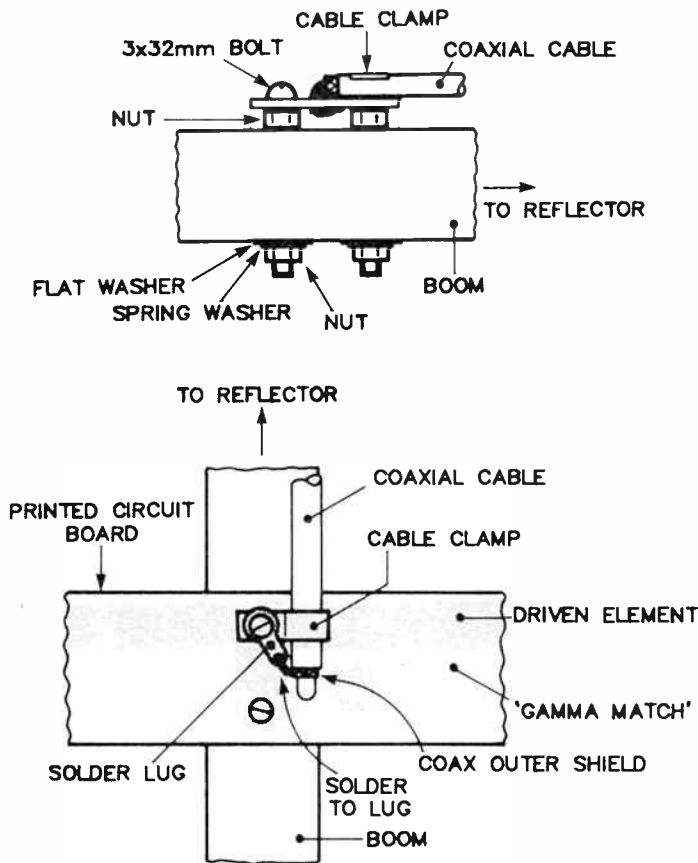


Figure 8. General detail of the driven element assembly showing also how the feedline is terminated.

The driven element assembles to the boom as shown (Figure 8), with the driven element track on the pc board uppermost. Secure the cable with the cable clamp beneath the rearward bolt, and solder the braid to the solder lug right up close to the cable. This is achieved more easily if you 'tin' both the braid and the solder lug with solder first. Use a hot iron with a medium diameter tip and work quickly. Try and avoid melting the coax's insulation. After you've completed this, seal the coax and the joints against the ravages of the weather by coating them liberally with a silicone sealant, such as Selley's 'Silastic'. The copper track dipole can be protected by spraying with clear lacquer.

The short length of coax passes over the reflector and should be secured to the boom with either insulation tape or a plastic 'zip-up' cable clamp. Your feedline to the rig should be terminated in a suitable connector and plugged into the coax from the dipole via a suitable coupling joint.

### Mounting

As vertical polarisation is predominantly used on the UHF CB band, the beam should be mounted with the elements vertical. So as to avoid a metal mounting mast (which is, naturally, vertical) interfering with the operation of the beam, a length of boom has been left behind the reflector. Thus, the beam can be 'cantilevered' from the mast, as shown here in Figure 9. It is quite light enough and short enough so as not to 'droop' noticeably.

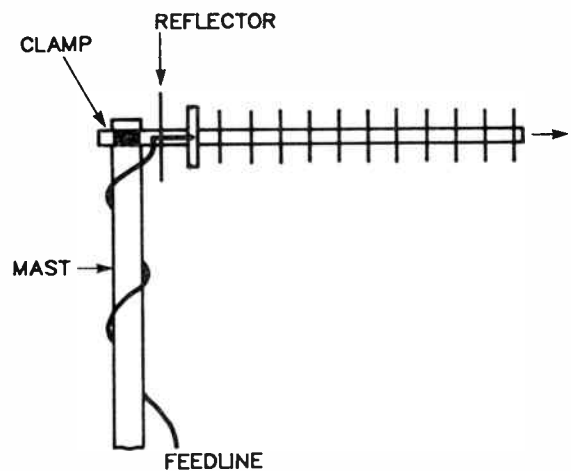


Figure 9. How the beam is to be mounted.

### SPECIFICATIONS AS MEASURED ON PROTOTYPE

No. of elements	13
Gain	12.5 dBi* (17.8 x)
Front-to-back ratio	16 dB (1/40th)
Beamwidth ('top down')	15° approx. (E-plane)
	20° approx. (H-plane)

\*Compared to an 'isotropic antenna' which theoretically radiates in all directions. Compared to a groundplane (a 'real' antenna), this antenna would have a gain of about 11 dB (12.5 x).

to p. 86. ▶

# LITTLE DICK'S SUMMER SIZZLERS



## SUMMER AT SEA IS MORE FUN WITH 'SAFETY' — GET A RADIO!

### VHF HAND-HELD TRANSCEIVER

Fantastic! Any *Old Salt* can have the security of VHF marine without the budget taking a dive. 12 channel programming for full local area lock-in PLUS re-programming capability. Switchable 0.5/2.5W power output. High sensitivity (better than 0.25uV) and more. Being hand-held (160x60x35mm), you can take it anywhere: home or in a life boat. Cat D-1404

**\$399**

### VHF SEAPHONE MARINE

What a bargain! One of our best transceivers with \$50 saving. Features ALL international channels in the 156 — 163MHz band, switchable 25W power output and Universal mounting Seaphone service lets you make calls from your craft. Cat D-1401

Was \$449



PLUS VHF antenna  
Cat D-4071 for only \$10 extra!  
SAVE \$57.50

**NOW \$399**

## 24-HOUR SAFETY MONITORING

## CLUBS, MARINERS — TUNE INTO VALUE!

### 27MHz MARINE HELICAL ANTENNA

This is it! A whip antenna for glass, wood and cement boats that doesn't need a ground plane. Low price includes mounting base, cable, simulated ground plane. Great value! Cat D-4070

**\$54<sup>50</sup>**

### SWORDFISH 27MHz HALF WAVE

Tough fibreglass half-wave — doesn't need a metal ground plane. Ideal for all hull types. Includes 'any-which-way' base with quick release lever. With mounting hardware. Cat D-4071

**\$67<sup>50</sup>**

### VHF MARINE WHIP FOR 156MHz

Be a winner! You won't lose with this great antenna. Suits most radios — ideal for our 'Seaphone' unit (D-1401). Complete with 'any-which-way' base. Cat D-4016

**\$67<sup>50</sup>**

### HORNET II MARINE AM/SSB

Fantastic! Our Hornet is a real high-flyer with full 27MHz (expandable) marine band, local AM plus SSB for extra range. And it's so versatile — doubles as a PA with optional horn. Features noise limiter and blanker, LED display. Cat D-1716



**\$299**

### MARINE RADIO HANDBOOK — this book could save your life!

The mariner's mate! All the scuttlebutt about selecting, fitting and using marine radio; rescue organisations. Includes maps, charts and times of monitoring stations. Cat B-9604



**\$8<sup>95</sup>**

### SEAWASP 27MHz MARINE AM

WOW! Just the trick for in-shore boating — with access to all CB frequencies. Plus a host of features. Squelch control, RF gain, channel selection control, CB/WX switch, RF Power/'S' Meter and more! Excellent value and safety. Cat D-1407

**\$199**

Includes 2 VHF weather channels (Rec only) Too!



### Don't leave shore without one!

### 5W 6-CH. TRANSCEIVER

Fantastic! Famous Uniden reliability plus full 27MHz marine features — all in a hand-held unit Goes anywhere! Connect to boat/external antenna for maximum power. Cat D-1125

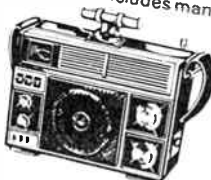
6 CHANNELS FITTED

**\$179**

FREE Alkaline Batteries for Cat D-1125 SAVE OVER \$11

### YACHTIES! GET ONE WHILE STOCKS LAST. MULTI-BAND RADIO/DIRECTION FINDER

Lost? Not for long with this affordable receiver! Built-in radio direction finder pin-points your position against AM stations. PLUS hear FM, CB, VHF and shortwave. Includes manuals. Cat D-2832

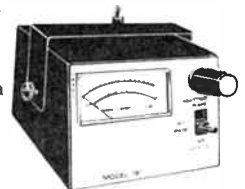


**\$119**

### TUNE THAT SET! SWR/POWER METER

Suitable for 27MHz Marine

Built-in strength field facility indicates precise antenna radiation, other RF energy measurement. SO-239 sockets for permanent antenna line placement. Cat O-1350



**\$24<sup>75</sup>**  
OR

Only \$10 if purchased with Hornet II (Cat D-1716)

**CB RADIO IS BACK IN FORCE!**  
Hand-held units that are fun and safe. Ideal for cyclists, bushwalkers — in fact Anyone!

**POCKET COM II SHORT-RANGE CB**

Really affordable communication! Effective over short distances: for construction sites, sporting teams, etc.



Cat D-1101  
**GET TWO FOR \$20**  
SAVE \$5.90

**\$12.95**

**HAND-HELD 3 CH. 1W TRANSCEIVER ... for some more power ... and even more power**  
**2W 3-CH. UNIDEN CB**      **3W 3-CH. CB**



Great for weekend explorers! It's light, compact and features the bushwaking/safety channel 27.620MHz. A real lifesaver in emergency situations. Cat D-1102

**\$99**



Cat D-1107

One of the most advanced 2W hand-held transceivers available! Gives that extra range when you need it most. With channel 14 crystals. Great features: squelch, battery strength LED and more!

**\$119**



Medium powered CB that could get you out of a 'heavy' situation. Fitted with channel 14 crystals, others left free for your favourite channels. Great Value! Cat D-1106

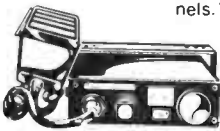
**\$129**

**AND NOW CBs FOR YOUR CAR, TRUCK OR CARAVAN (or home — with suitable power supply M-9545: \$54.95)**

**K40 MINI AM With Full Power**

WOW! Even on a strict budget you can enjoy CB action. But don't let the ultra-small size and low price fool you. Delivers legal maximum power on ALL 40 channels. With mic. Cat D-1443

DOC Approval No. 249A049

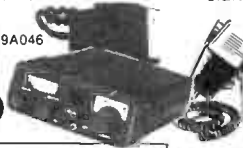


**\$109**

**40-CH. 'MIDLAND' 77-001**

Compact! Powerful! Ideal for small cars, cramped trucks — wherever space is limited. Packed with the best features: signal strength meter, LED channel display and more. Cat D-1445

DOC Approval No. 249A046



**\$135**

**HORNET II 40-CH. AM/SSB**

Just great! Hornet II proves you don't have to pay more for quality. Features channel and mode selectors, noise blanker/ANL switch, squelch, RF gain, clarifier and much more. Cat D-1710

DOC Approval No. 249A006



**\$299**

**TRUCKIES & CLUBS/ OWNERS — GO FURTHER!**  
**Great Range of Antennae!**

Complete from \$28.50

Check our range! DSE have an antenna to suit your needs and budget. Like the 27MHz gutter grip brilliant reception easy installation slips onto car's r-n gutter (Cat D-4411). Only \$28.95 PLUS a selection of magnetic helical whip and base antennae

**'SUNDOWNER' UHF 40-CHANNEL CB**



The pick of the crop! UHF communication that's as clear as country air. Backed with superior features: squelch, duplex repeater, RX/TX LEDs and more. So good, even a city-slicker will love it.

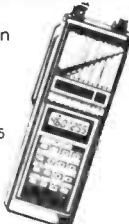
Cat D-1806

**\$375**

**LISTEN TO THE CONFIDENTIAL BANDS! HX-2000 HAND-HELD SCANNER**

WOW! Compact, go-anywhere unit 'eavesdrops' on all the action. Take it with you: in the car, to the office. Has many base station features, including priority, scan and search. Cat D-2815

**\$449**



**MX 4000 'MOBILE' SCANNER**

Hear it! News as it actually happens while you're driving... avoid traffic hazards, delays. Covers 20 channels — all programmable — including 800MHz and air. Loaded with features: priority, scan and searcher, LCD frequency display and more. Cat D-2818

**\$599**



**BIG DADDY SCANNER! YAESU FRG-9600 UHF/VHF**



This is it! The BIG ONE! Covers UHF/VHF, AM/FM and SSB. Hear any type of broadcast: police, military, air and hams. 100 keypad programmable memory takes you through 60- to 905MHz continuously. Features 7 tuning/ scanning rates output jacks. Cat D-2825

**\$799**

SPECIAL! Buy our YAESU FRG-9600 and save \$25 on our Broadband 65-520MHz antenna (Cat D-4432). That's 1/2 PRICE!

Don't be fooled by imitations!

**KEEP IN TOUCH WITH OVERSEAS WITH DSE WORLD RADIO RECEIVERS ...**

**FRG-8800 HF RECEIVER**

Yaesu — a respected name in communications. And DSE offers this superb Yaesu HF receiver with a host of impressive features. There are 10 built-in memories, digital frequency entry and manual tuning, a S/SINPO graphic indicator and much more! Plus CAT control and VHF capability.

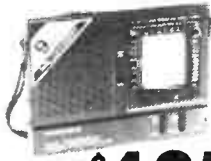


Cat D-2820

**\$899**

**PORTABLE 9 BAND RADIO**

An enthusiast's delight! Tunes in to AM, FM and up to 7 SW bands within the 5.95 and 21.75MHz range. Offers superior selectivity and sensitivity. Ceramic filter cuts interference.



Cat D-2837

**\$125**

**MULTIBAND AM/FM /SW 1.2.3.4.**

Great introduction to SW listening. And with the FREE stereo headphones, it's sensational value! Tune into local AM/FM stations PLUS 4 SW bands. Provides endless hours of enjoyment.



Cat D-2835

WAS \$79

**\$59**

**SANGEAN ATS-803 MULTIBAND RADIO**

It's got the 'it'! More features than even the most critical enthusiast could demand. Tune into AM, FM or any of the 12 SW bands by either direct frequency key-in, auto or manual scanning. FIVE tuning functions in all. Adjust audio with treble and bass controls to suit personal tastes. Features sleep button, RF gain control and much more. Cat D-2831

**\$329**

**VHF CONVERTER FOR FRG-8800s**

Add versatility to Yaesu FRG-8800 receivers (Cat D-2820, 2821). Covers frequency range 118 — 174MHz. Fits neatly inside receiver. With own telescopic antenna. Cat D-2823

**\$189**

**WORLD RADIO/TV HANDBOOK**

A handy reference book every enthusiast should have! A comprehensive listing of valuable information: frequencies of long, medium and short range broadcasters, charts, and more.



Cat B-2086

**\$32.50**

SAVE! SHORTWAVE ANTENNA KIT FREE WITH D-2831/2820/2821  
FREE WITH ANY SCANNER BOUGHT — AUSTRALIAN LIST FREQUENCY \$8.95



**\$829**

# BENELEC MULTIMETERS FR



**DT-845A (21 Ranges)**



**DT-850 (27 Ranges)**

## DT-850 DT-845A

Display: 3½ digit LCD, 10mm Height  
max. indication 1999  
Overrange Indication: "1" at the highest digit  
Polarity: "-" sign automatically  
Sampling Time: 0.5 second  
Operating Environment: 0°C 40°C, less than  
80% R.H.  
Storage Environment: -20°C 60°C, less than  
70% R.H.  
Power: DC 3V, 2 pcs UM-3 (AA Size) battery  
Battery Life: 500 Hours typical  
Low Battery Indicator: "B" sign for warning  
Dimensions: 160(L) x 80(W) x 31(H) mm  
Weight: 210g (190g without battery)  
Accessories: test leads, 1 pair  
UM-3 battery, 2 pcs  
Spare fuse (0.2A), 1 pce  
Instruction manual, 1 pce

### DISPLAY

- Numerical Display: 3.5 digit + LCD, maximum reading 1999.
  - Unit and Sign: V, K $\Omega$ ,  $\infty$ , BATT, AC, DH, -
- RANGE SELECTION: Auto ranging on Volt and OHM

POWER SUPPLY: Two 1.5V Batteries, type LR-44 or SR-44

LOW POWER OHM RANGES: for in-circuit resistance measurements at voltage levels below 0.3 volts.

DIMENSIONS: 163 x 19 x 28 mm

## PD-1800



### Accessories:

- battery (LR44, 1.55V) x 2
- hard cover case x 1
- instruction manual x 1
- test leads x 1

DC Voltage 2,000mV, 20V, 200V, 400V  
(Accuracy)  $\pm 2\%$  rdg  $\pm 2$  dgt  
AC Voltage 2,000mV, 20V, 200V, 400V  
(Accuracy)  $\pm 3\%$  rdg  $\pm 5$  dgt

Resistance 200 $\Omega$ , 2,000 $\Omega$ , 20k $\Omega$ , 200k $\Omega$ , 2,000K $\Omega$   
(Accuracy)  $\pm 2\%$  rdg  $\pm 2$  dgt  
Continuity Check Ohms of test circuit 200 $\Omega$   $\pm$  10 $\Omega$

## DT-710

Display 3-1/2 digit LCD max reading of 1999

Range Auto-ranging

Polarity Automatic no indication for polarity, minus (-) sign for negative polarity.

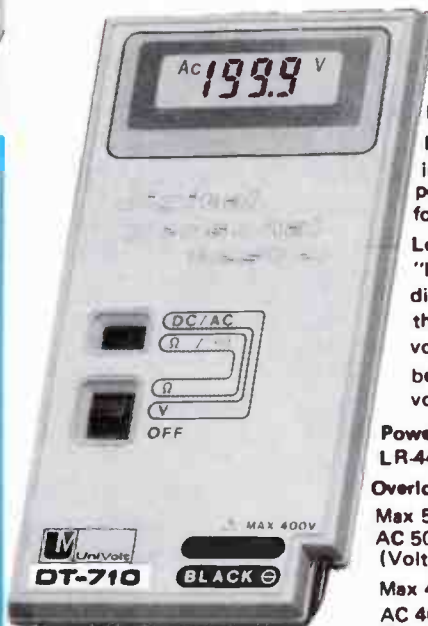
Low battery indication "B" mark is displayed when the battery voltage drops below operating voltage

Power Supply LR-44(1.55V) x 2

Overload protection

Max 500V DC or AC 500V RMS (Voltage)

Max 400V DC or AC 400V RMS (Resistance)



**Model DT-710**

# BENELEC

Pty Ltd.

1 Greville St. Randwick NSW 2031 **PHONE: (02) 665 8211**

# OM BENELEC MULTIMETERS

## DT-860

Display LCD max. indication 1999  
 Overrange Indication: "1" or "-1"  
 Polarity: "-" indication automatically  
 Input Impedance: 10 Meg  $\Omega$   
 Operating Temperature: 0° ~ 40°C, 80% R.H.  
 Power Requirement: DC 3V, 2 pcs. UM-3 battery  
 Battery Life: 300 hours typical  
 Dimensions: 145(D) x 82(W) x 28(H) mm  
 Weight: 180g, excluding battery  
 Accessories:  
 Safety test leads, 1 pair  
 UM-3 (1.5V) battery, 2 pcs  
 Spare fuse (0.2A), 1 pce  
 Instruction manual, 1 pce



## DT-1000

Display: LCD max. indication 1999  
 Overrange Indication: "1" or "-1"  
 Polarity: "-" indication automatically  
 Input Impedance: 10 Meg  $\Omega$   
 Operating Temperature: 0° ~ 40°C,  
 80% R.H.  
 Power Requirement: DC 9V,  
 006P battery  
 Battery Life: 200 hours typical  
 Dimensions: 160(D) x 84(W)  
 x 26(H) mm  
 Weight: 200g excluding  
 battery

**new**

**new**

## DT-4500

## DT-4600

### Relative Test (Manual range)

Ranges: DV V, AC V, DC Current, AC Current, Resistance.  
 Displayed Value: Measuring value (Dx) - Relative value (Ds)

When the REL button is pushed, the input applied at that time is stored as a ZERO reference point.  
 Subsequent readings display deviations from the reference point.

### Data Hold

Ranges, Functions: DC V, AC V, DC Current, AC Current, Resistance, Diode, dBm, Temperature, (DT-4600).  
 Relative (DT-4500)

### Peak Hold (Manual Range)

Ranges, Functions: DC V, AC V, DC Current,  
 AC Current, Temperature.

### DT-4500 only

Accuracy: (Each range accuracy)  $\pm (2\% + 100 \text{ dgt})$   
 Temperature:  $\pm 1 \text{ dgt}$   
 DC Acquisition Time: 5ms  
 AC Acquisition Time: 250ms

### General Specifications:

- Display LCD 4 1/2 digits reading of 24999 frequency (99999) and annunciators
- Range Auto or Manual Ranging
- Polarity Automatic no indication for positive polarity, minus (-) sign for negative polarity
- Sampling 2 ~ 5 times/s
- Over range indication "OL" mark indication
- Low battery indication "BT" mark is displayed when the battery voltage drops below operating voltage
- Calibration 1 year for specified accuracy
- Battery life Approx 50 Hours (Manganese Battery)  
 Approx 100 Hours (Alkali Battery)
- Power supply 9V Battery or AC Adaptor (Option)
- Double fuse 250V 0.5A, 600V 4A (DT-4500) or 250V 4A (DT-4600)
- Size 177(L) x 88(W) x 43(H) mm
- Weight Approx 360g
- Accessories Instruction Manual ..... 1  
 Battery (6F 22) ..... 1  
 Safety Test Lead ..... 1 set  
 Spare Fuse (0.5A/250V) ..... 1

### Temp Test (°C or °F reading)

Sensor: K type sensor  
 Measuring range: -50°C ~ 1200°C or -58°F ~ 2192°F  
 Resolution: 1°C or 1°F  
 Accuracy:  $\pm 0.5\% \pm 3 \text{ dgt}$  (°C)  
 $\pm 0.5\% \pm 5 \text{ dgt}$  (°F)



► from p 81.

A variety of suitable mounting methods may be used. A U-bolt and clamp, commonly used to mount TV antennas, is one way, but requires drilling the boom, weakening it and encouraging corrosion. A better method is to use a special U-clamp, as shown in Figure 10. These clamps will be supplied with each kit. It will fit 40 x 40 mm square masts (i.e: dressed timber) or round-section mast of 40 mm diameter. The two thumb screws securely clamp the boom and mast together. The thumb screws, in turn, are secured by the locking nuts.

See that the boom sits horizontal once it's secured. If you so require, the antenna may be horizontally polarised by rotating it 90 degrees so that the elements are horizontal.

## Feedline

As mentioned at the beginning, the feedline is an important consideration in station system performance. Hence, the best quality low-loss coax you can afford is recommended. In addition, you should keep the line length as short as possible, consistent with getting the antenna as high as practicable. Don't put the antenna mast 100 metres away from the rig's location, put it as close as practicable.

If you have a substantial run of feedline between the antenna and the rig, you'll have to spend proportionately more on the feedline to keep the losses down. The larger diameter cables have less loss than the common 6.5 mm cables (such as RG58). If you have to use any length of 6.5 mm cable, get a low-loss type and use the shortest possible length — preferably less than 300 mm.

Andrews FHJ4 is a solid (i.e: not flexible) line with very low loss at 477 MHz and relatively high cost as a consequence. Special connectors are required and are not easily fitted. Consider FHJ4 as the 'Rolls Royce' of cables. Belden 9913 is a semi-flexible coax that comes highly recommended and standard 'Type N' connectors can be fitted. If you have a run of less than ten metres, then RG213 may be used as it's quite economical, but 9913 would be better.

## Rotators

Any light to medium duty rotator may be used for 'aiming' this beam. The height of unsupported mast above the rotator should really be no more than a metre. A length of flexible cable should run between the antenna and the main feedline with some slack to allow rotation without straining the feedline.

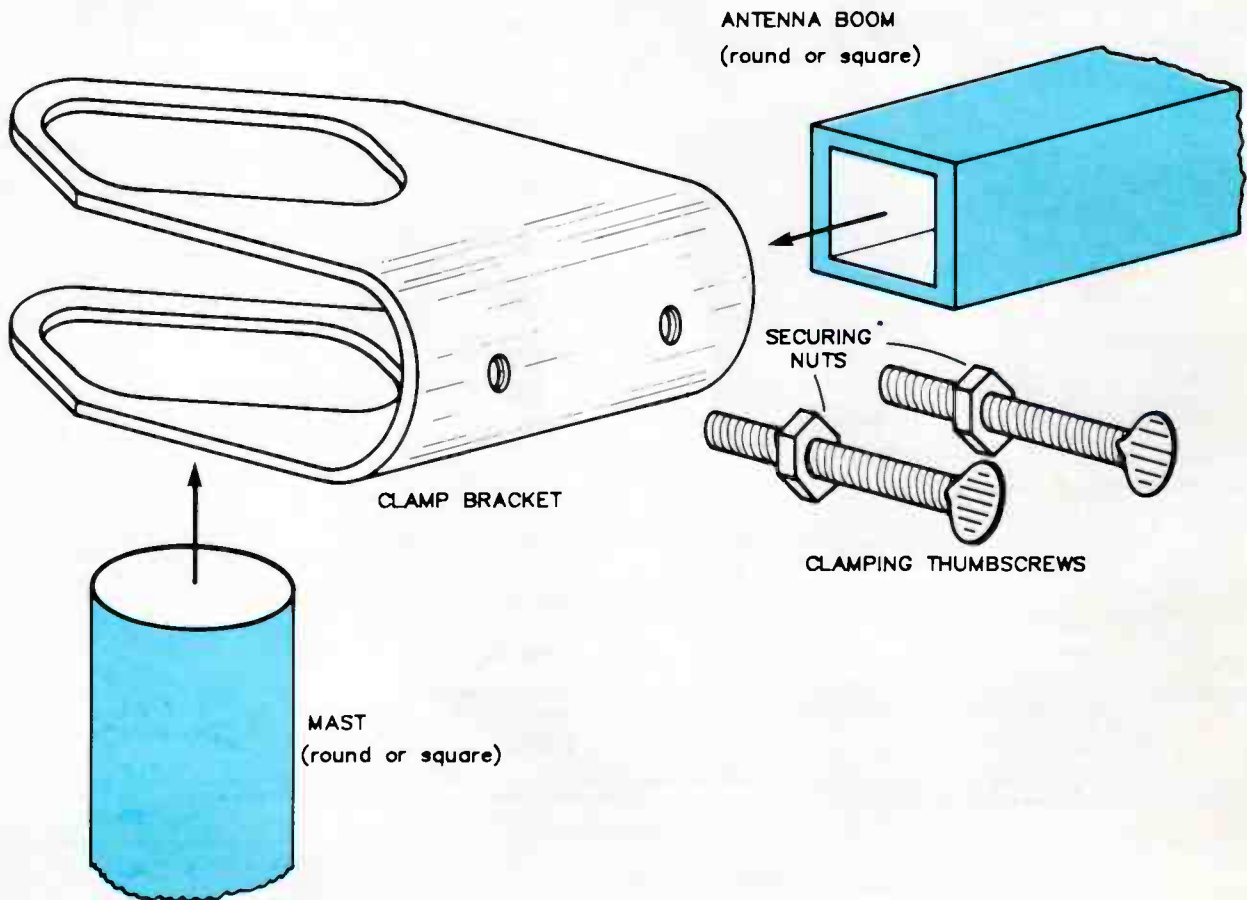
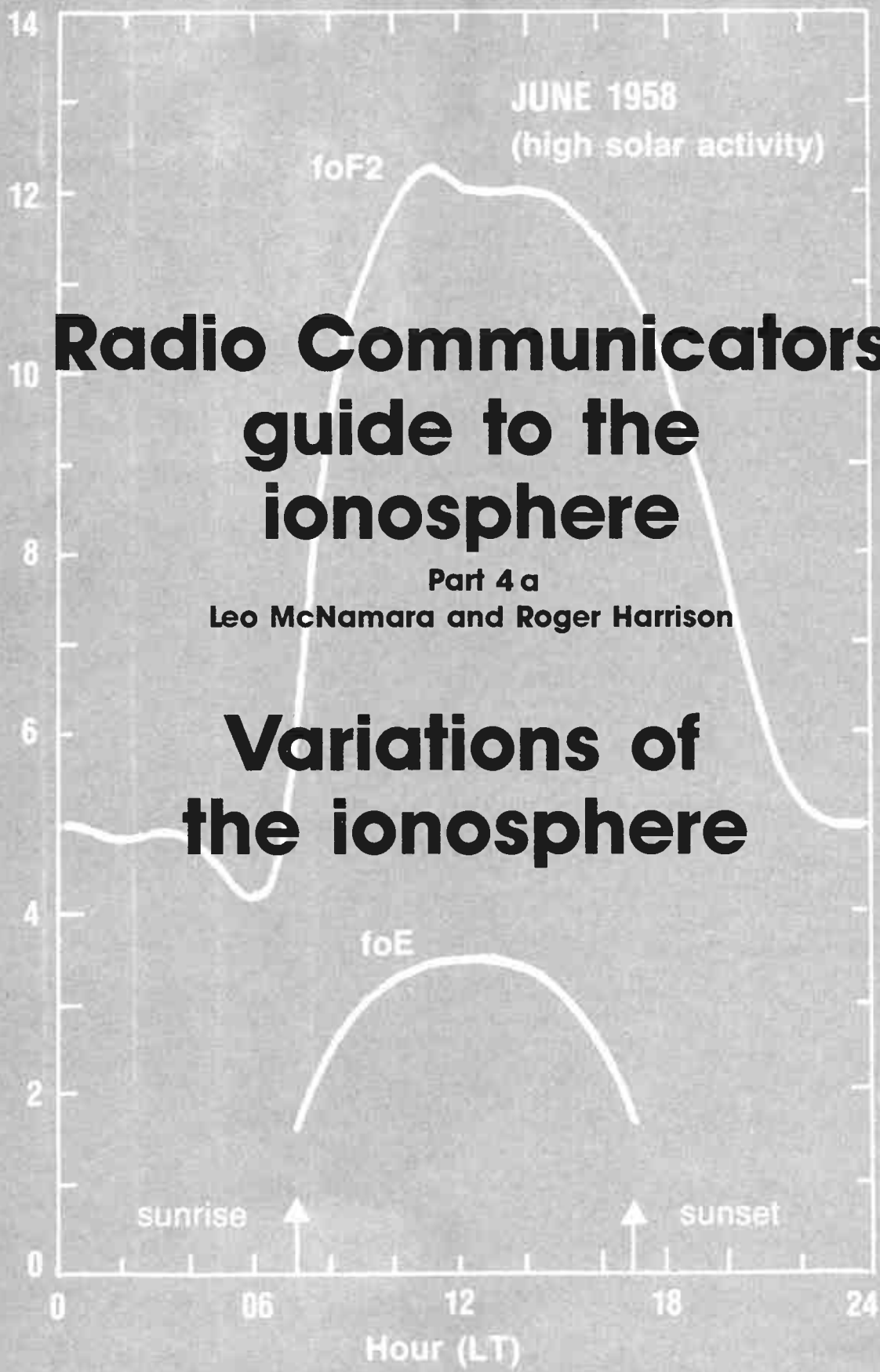


Figure 10. The beam is secured to the mast with this specially-designed U-clamp. Note that either round or square-section mast may be employed.



# Radio Communicators guide to the ionosphere

Part 4 a  
Leo McNamara and Roger Harrison

## Variations of the ionosphere

WE HAVE ALREADY seen that the ionosphere varies with height, or altitude, ranging from the D layer at 50 to 90 km up to the F layer at 200 to 600 km. The fact that the ionosphere is created by the sun immediately suggests that it will vary with time of day, season and position on the surface of the earth. In fact, its variation is very similar to the air temperature which weather forecasters predict.

Generally speaking, the electron density in the ionosphere is greatest in summer, in the middle of the day and near the equator. This simple picture is not quite true as we shall see, but it will suffice for the present. The ionosphere also varies significantly with solar activity, as the amount of UV radiation from the sun waxes and wanes every eleven years or so. We shall consider the variations of the ionosphere in some detail because the frequencies available for HF communications have the same variations. The five main variations are illustrated in Figure 4.1.

**VARIATIONS OF THE IONOSPHERE**

1. **DIURNAL** (throughout the day)
  - Variation with solar zenith angle
2. **SEASONAL** (throughout the year)
3. **LOCATION** (geographic & geomagnetic)
4. **SOLAR ACTIVITY**
  - Solar cycle & disturbances
5. **HEIGHT** (different layers)

Figure 4.1. The five main variations of the ionosphere which must be taken into account in order to predict HF communication conditions successfully.

### Diurnal variation

The word "diurnal" simply means "throughout the day". The diurnal variation of the critical frequencies of the D, E and F1 layers is very simple. These layers are not there at night, and during the day the critical frequencies depend almost exclusively on the zenith angle of the sun.

The zenith angle of the sun (or any other object in the sky) is the angle between the observer to the position directly overhead (called the zenith) and a line from the observer to the sun — see Figure 4.2. If the sun is vertically overhead, the zenith angle is zero, whereas at sunrise and sunset it is around 90° because the line from the observer to the sun is more or less horizontal. Because the surface of the earth is

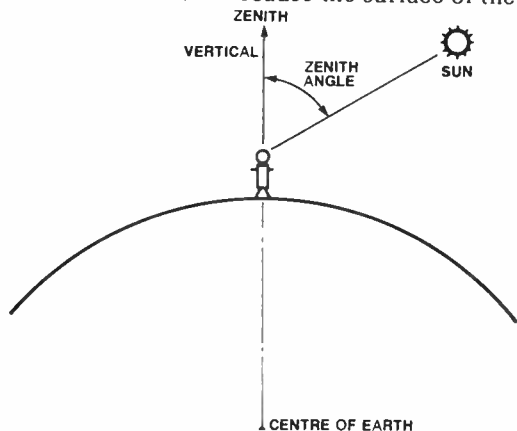


Figure 4.2. The zenith angle of the sun is the angle between the line to the point directly overhead of the observer (the zenith) and the line to the sun.

curved, it is a little messy to work out the zenith angles, but we do not need to worry about that here.

At midday on September 23 and March 21 (the equinoxes), the sun will be vertically overhead of an observer at the equator and the zenith angle will be zero. At midday on December 21, the sun will be vertically overhead at the Tropic of Capricorn, while at midday on June 21 it will be vertically overhead at the Tropic of Cancer.

We have belaboured the zenith angle because once we know it, or can estimate it, we can work out a pretty good estimate for the critical frequencies of the E and F1 layers. If the zenith angle is called "Z" and the level of solar activity is described by the sunspot number "R", then the critical frequencies for the E and F layers, foE and foF1, are given approximately by:

$$foE = 0.9[(180 + 1.44R) \cos Z]^{1/4} \text{ MHz} \quad \dots 4.1$$

and

$$foF1 = (4.3 + 0.01R) \cos^{0.2} Z \text{ MHz.} \quad \dots 4.2$$

These are empirical equations which fit the observations of foE and foF1 fairly well, and are included here mainly to illustrate how values of foE and foF1 may be calculated in practice. They are not as complicated as they may first appear — many simple electronic calculators can do the work for us without too much hassle. We do not even have to know what a "COS" is, since we can just press the COS button on our calculator. Actually, COS is a handy thing to know about because we shall encounter it again when we work out the relation between a critical frequency and the maximum frequency that can be used on a given circuit. The COS (short for COSINE) of an angle "A" in a right-angled triangle (see Figure 4.3) is defined as the ratio of the lengths of two sides:—

$$\text{COS } A = XY / YZ. \quad \dots 4.3$$

For example,  $\cos 0 = 1$ , because the triangle collapses to a horizontal line and  $YZ = XZ$ . Again,  $\text{COS } 90 = 0$ , because the triangle collapses to a vertical line and  $ZX = 0$ .

For angles very near 90°

$$\text{COS } A = \frac{XZ}{YZ} \approx \frac{0}{YZ} = 0$$

For very small angles

$$\text{COS } A = \frac{XZ}{YZ} \approx 1$$

ANGLE	COSINE
0°	1
30°	0.866
45°	0.707
60°	0.5
90°	0

Figure 4.3. The cosine of an angle A in a right-angled triangle is defined by the ratio of the length of the side adjacent to the angle, and the hypotenuse of the triangle. The hypotenuse is the longest side of the triangle and is opposite to the right angle.



The number  $1/4 (= 1/2 \times 1/2)$  outside the square brackets in equation 4.1 tells us to take the square root twice, once we have calculated the value of the term inside the brackets. Most school-level calculators also have a square-root button. When  $Z = 90$  degrees, and  $R = 0$  for low solar activity, we have

$$\begin{aligned} \text{foE} &= 0.9 [(180 + 0) \times 0]^{1/4} \\ &= 0. \end{aligned}$$

In other words, foE is zero at sunrise and sunset. When  $Z = 0$  and the sun is vertically overhead, for  $R = 0$ , we have:

$$\begin{aligned} \text{foE} &= 0.9 [(180 + 0) \times 1]^{1/4} \\ &= 0.9 \times 3.66 \\ &= 3.3 \text{ MHz.} \end{aligned}$$

We do not have to worry very much about calculating foF1 because the F1 layer is not very important for HF communications. The calculation is a little messier, which is another good reason for ignoring the F1 layer here, although the interested reader may like to take advantage of the  $y^x$  button which many calculators have.

The F1 layer is, of course, taken into account in full prediction systems. Under some conditions, such as at high latitudes and during ionospheric storms (which we shall deal with later), the F1 layer becomes more important than the F2 layer.

Table 4.1 gives some values of foE and foF1 for different levels of solar activity and for different solar zenith angles. Figure 4.4 shows (among other things) the diurnal variation of foE and foF1 for Canberra, Australia, for two seasons and two levels of solar activity. While easy to calculate, foE and foF1 are not as important for HF communications as foF2, the critical frequency for the F2 layer. Unfortunately, foF2 is not easy to calculate, as we shall see later. However, foF2 also displays diurnal, seasonal, latitudinal and solar cycle variations, and it is these which are of interest in this article. These variations are illustrated in Figure 4.4, along with those of foE and foF1, and in Figure 4.5.

The diurnal variations of foE and foF1 are more or less what we would expect, the critical frequencies reaching their greatest values at noon. The F1 layer shows up as a separate layer only during the day, from about an hour or two after sunrise to an hour or two before sunset. The E layer does not completely vanish at night, usually staying at around foE = 0.4 MHz. However, such low critical frequencies are difficult to observe and have little consequence for HF communications, so we shall assume that foE drops to zero at night.

The diurnal variation of foF2 is often rather complicated. It reaches its lowest value just before dawn, recombination having eaten away at the electrons all night. Then the sun comes up, and foF2 rises rapidly as photoionization starts creating a supply of free electrons again. The F2 layer differs from the E and F1 layers in that it survives the night, albeit in a somewhat depleted state. This fact, together with the fact that the critical frequencies are highest in the F2 layer, makes the F2 layer the most important layer as far as HF communications are concerned.

## Seasonal variation

The ionosphere varies throughout the year, partly because the solar zenith angle has a seasonal as well as diurnal variation, but also because of changes in the neutral atmosphere from which the ionosphere is created. In the winter, the zenith angle at noon is always greater than the corresponding angle in summer. We would therefore expect the critical frequencies of each of the layers to be greater in summer than in winter. This is found to be the case for the D, E and

LOCATION	LAT.	LONG.	HOURL	R12*	Z	cos(Z)	foE	foF1
LONDON	51.0	0.0	8	0.0	74.1	0.274	2.4	3.3
	51.0	0.0	8	100.0	74.1	0.274	2.8	4.1
	51.0	0.0	12	0.0	52.4	0.610	2.9	3.9
	51.0	0.0	12	100.0	52.4	0.610	3.4	4.8
	51.0	0.0	16	0.0	71.5	0.317	2.5	3.4
	51.0	0.0	16	100.0	71.5	0.317	2.9	4.2
MOSCOW	55.0	37.0	8	0.0	72.1	0.307	2.5	3.4
	55.0	37.0	8	100.0	72.1	0.307	2.8	4.2
	55.0	37.0	12	0.0	56.5	0.551	2.8	3.8
	55.0	37.0	12	100.0	56.5	0.551	3.3	4.7
	55.0	37.0	16	0.0	77.0	0.225	2.3	3.2
	55.0	37.0	16	100.0	77.0	0.225	2.6	3.9
NEW DELHI	29.0	77.0	8	0.0	65.0	0.422	2.7	3.6
	29.0	77.0	8	100.0	65.0	0.422	3.1	4.5
	29.0	77.0	12	0.0	30.4	0.862	3.2	4.2
	29.0	77.0	12	100.0	30.4	0.862	3.7	5.1
	29.0	77.0	16	0.0	64.7	0.428	2.7	3.6
	29.0	77.0	16	100.0	64.7	0.428	3.1	4.5
NEW YORK	41.0	74.0	8	0.0	71.1	0.323	2.5	3.4
	41.0	74.0	8	100.0	71.1	0.323	2.9	4.2
	41.0	74.0	12	0.0	42.5	0.737	3.1	4.0
	41.0	74.0	12	100.0	42.5	0.737	3.5	5.0
	41.0	74.0	16	0.0	66.6	0.397	2.6	3.6
	41.0	74.0	16	100.0	66.6	0.397	3.0	4.4
SYDNEY	-34.0	151.0	8	0.0	65.5	0.415	2.6	3.6
	-34.0	151.0	8	100.0	65.5	0.415	3.1	4.4
	-34.0	151.0	12	0.0	32.5	0.843	3.2	4.2
	-34.0	151.0	12	100.0	32.5	0.843	3.7	5.1
	-34.0	151.0	16	0.0	63.7	0.443	2.7	3.7
	-34.0	151.0	16	100.0	63.7	0.443	3.1	4.5
TOKYO	36.0	140.0	8	0.0	65.0	0.422	2.7	3.6
	36.0	140.0	8	100.0	65.0	0.422	3.1	4.5
	36.0	140.0	12	0.0	37.6	0.792	3.1	4.1
	36.0	140.0	12	100.0	37.6	0.792	3.6	5.1
	36.0	140.0	16	0.0	69.2	0.354	2.5	3.5
	36.0	140.0	16	100.0	69.2	0.354	2.9	4.3
EQUATOR	0.0	0.0	8	0.0	62.2	0.467	2.7	3.7
	0.0	0.0	8	100.0	62.2	0.467	3.2	4.6
	0.0	0.0	12	0.0	2.5	0.999	3.3	4.3
	0.0	0.0	12	100.0	2.5	0.999	3.8	5.3
	0.0	0.0	16	0.0	57.9	0.532	2.8	3.8
	0.0	0.0	16	100.0	57.9	0.532	3.3	4.7

\*Sunspot number

TABLE 4.1:

The values of the critical frequencies of the E and F layers, foE and foF1, for March at 08, 12 and 16 local time, for low (R = 0) and high (R = 100) solar activities, and for seven locations. Also listed are the zenith angles, Z, and their cosines, cos(z).

F1 layers, but not for the F2 layer at mid-latitudes.

The fact that foF2 at midlatitudes is greater in winter than in summer is known as the *midlatitude seasonal anomaly*. Figures 4.4 and 4.5 show how the critical frequencies foE, foF1 and foF2 vary with season. January is mid-summer at Canberra and mid-winter at Manila, while June is mid-winter at Canberra and mid-summer at Manila. Note that Manila is a low-latitude station, whereas Canberra is a mid-latitude station.

## Latitudinal variations

As with the seasonal variation, part of the variation of the ionosphere with position on the earth, particularly latitude, is due to the variation with solar zenith angle. Once we get out of the tropical zone between the Tropics of Capricorn and Cancer, the solar zenith angle can never be zero, and for a given time of day increases as we go towards the poles.

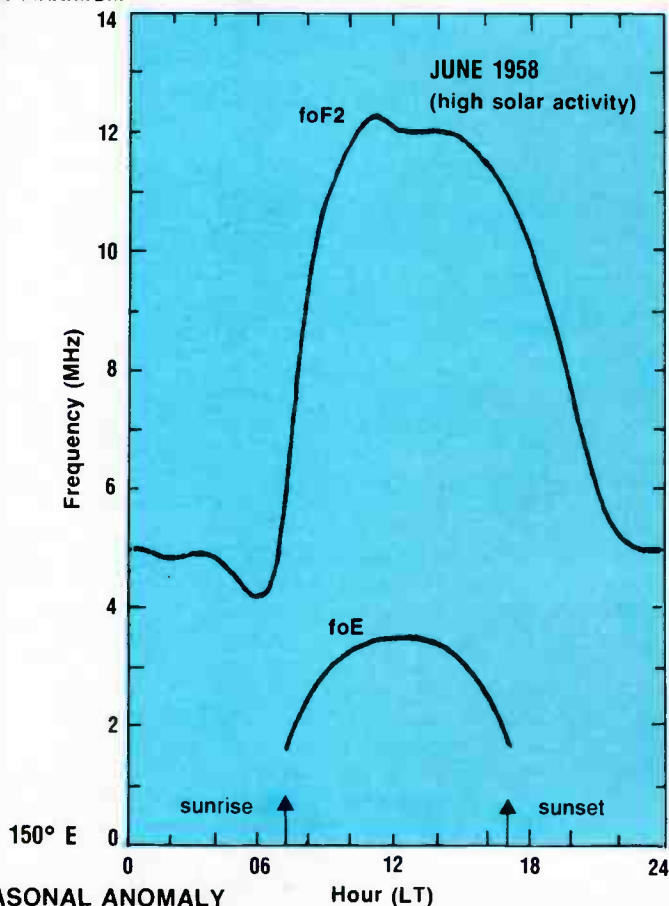
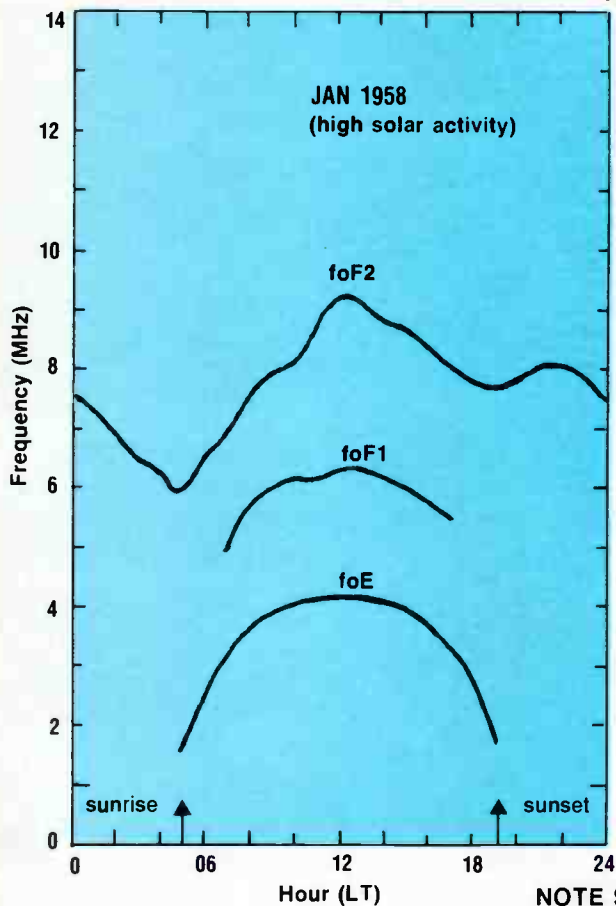
However, even when this effect is taken into account, the ionosphere is found to have considerable variation with latitude. The extreme cases of the equatorial and polar ionospheres are found to bear little resemblance to each other, as we shall see shortly and in later parts. Matching panels of Figures 4.4 and 4.5 may be compared to determine the variations of the ionosphere from mid to low latitudes.

## Variations from day to day

Just as the air temperature varies from day to day, so does the ionosphere. Our knowledge of the ionosphere is not yet ▶

## TYPICAL MID-LATITUDE STATION — CANBERRA (35°S)

SOLAR MAXIMUM



SOLAR MINIMUM

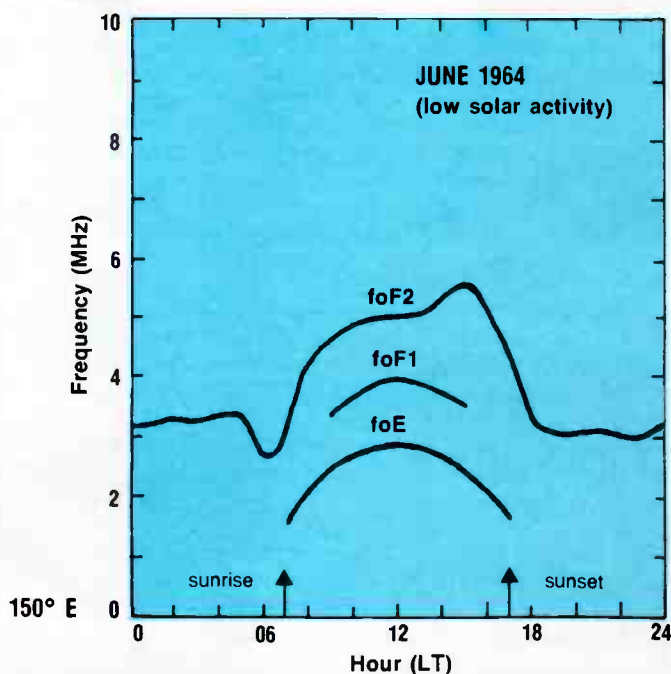
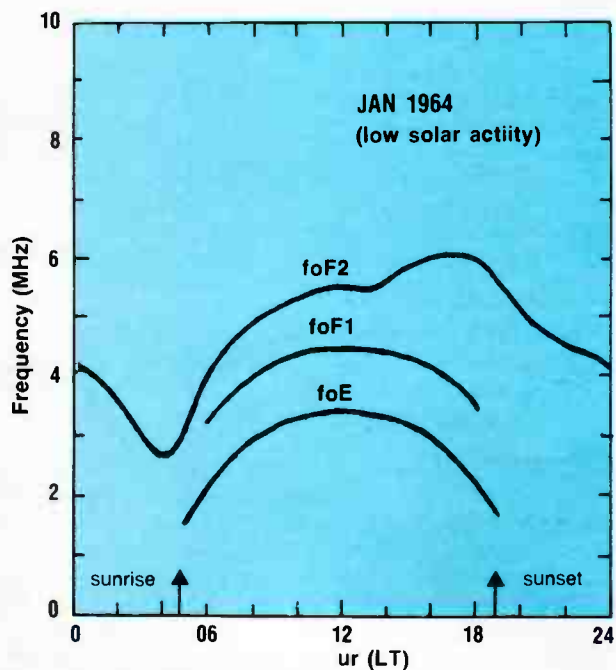
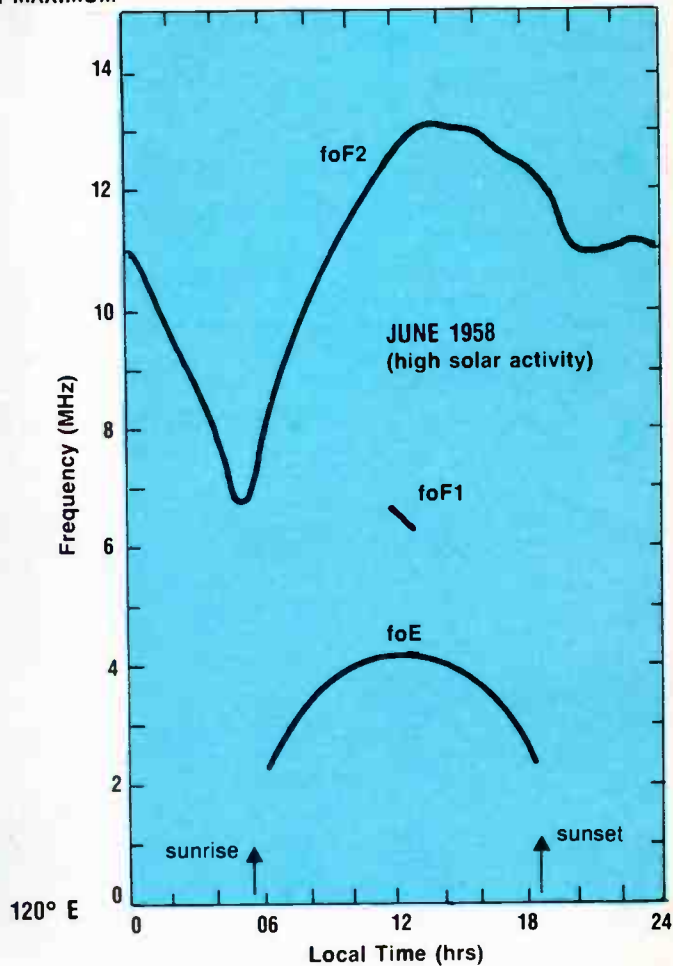
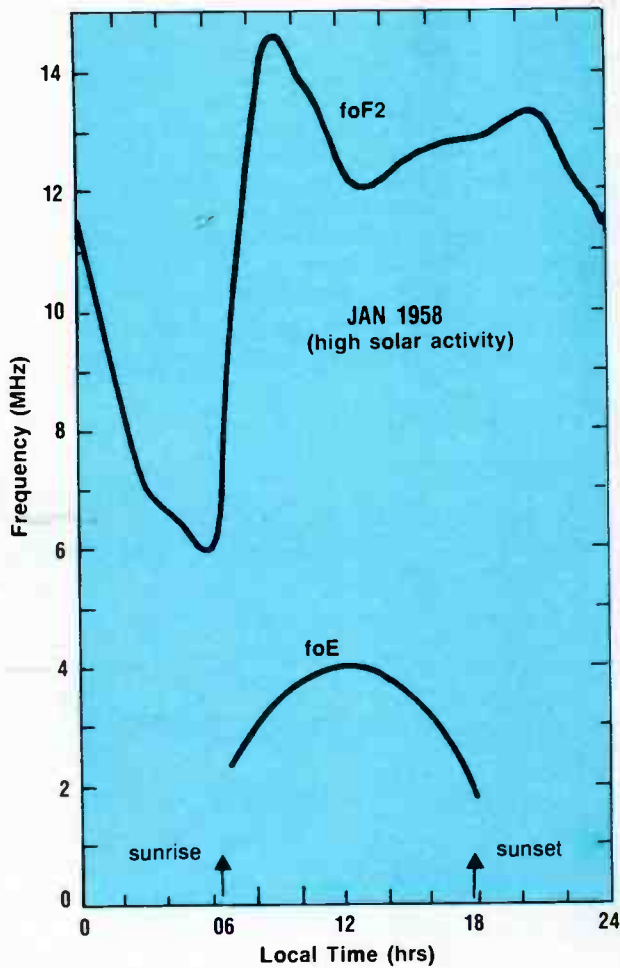


Figure 4.4. Variations throughout the day of the critical frequencies of the E, F1 and F2 layers, foE, foF1 and foF2, for Canberra for summer (January) and winter (June) and for two levels of solar activity (high, 1958; low, 1964). Note that there is no F1 layer for winter at high levels of solar

activity, and that the winter values of foF2 during the day at high levels of activity exceed the summer values. The latter phenomenon is known as the mid-latitude seasonal anomaly. Critical frequencies are significantly higher at high levels of solar activity.

## TYPICAL LOW-LATITUDE STATION — MANILA (13° N)

SOLAR MAXIMUM



SOLAR MINIMUM

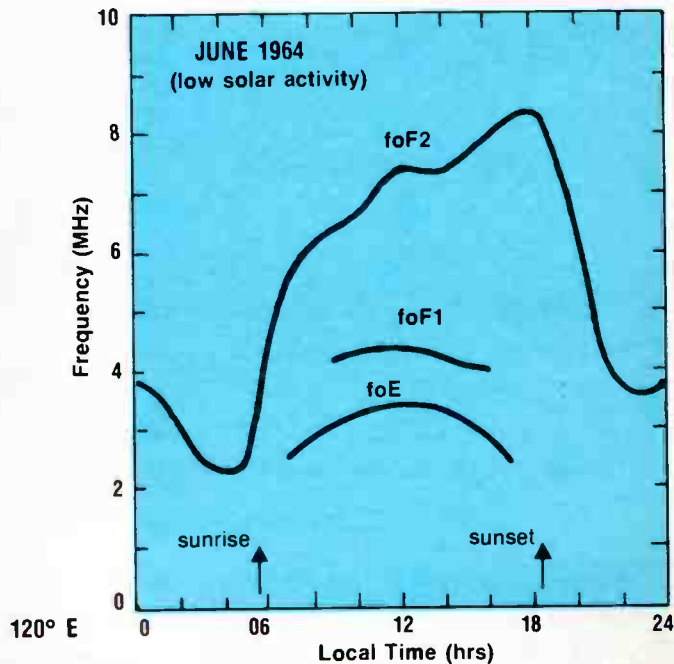
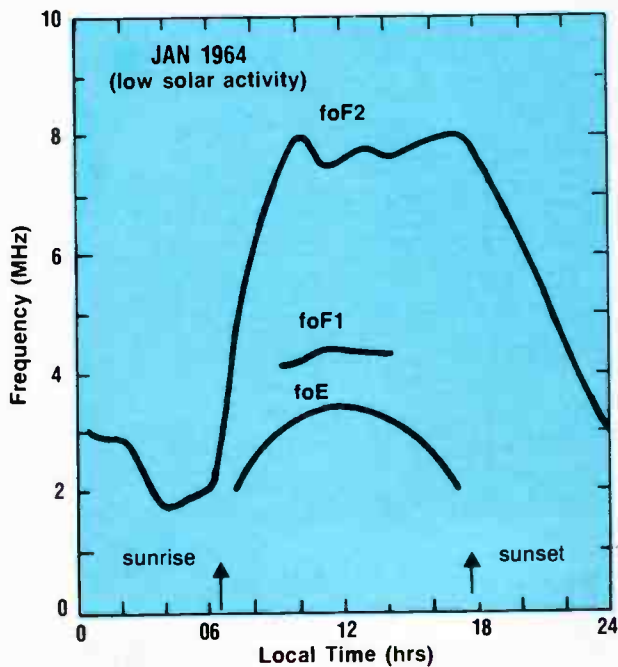


Figure 4.5. Variations throughout the day of the critical frequencies of the E, F1 and F2 layers, foE, foF1 and foF2, for Manila for summer (June) and winter (January), and for

two levels of solar activity (high, 1958; low, 1964). Note that the F1 layer is not important at this low latitude station.

# WIN WIN WIN

**this fabulous Yaesu scanner from Dick Smith Electronics**

Don't miss this opportunity to win a really top-line scanner — this Yaesu FRG-9600 scanner from Dick Smith Electronics. It has many functions and features not seen on other scanners — especially the ability to receive single sideband (SSB) signals. In reviewing the FRG-9600 in the September '85 issue of AEM, Roger Harrison said:

*“The FRG-9600 is a well-thought-out unit, easy to use and with facilities and features that will appeal to many — whether newcomers to scanning on the VHF/UHF spectrum or ‘old hands’.”*

Dick Smith Electronics, in conjunction with Australian Electronics Monthly, is offering a Yaesu FRG-9600 scanner as the prize in this simple contest. The unit provides continuous coverage from 60 through 905 MHz and features 100 memory channels. Five reception modes are provided — FM narrow and wide, AM narrow and wide, plus SSB (unique to

the Yaesu). The unit can scan over the full frequency range, preset frequency limits or across the memory channels. Provision is made for 'priority' channel selection, which is momentarily tested every three seconds, when activated, while listening to other channels. Selectable tuning steps are provided on the different reception modes. A 24-hour clock/timer is incorporated. The large display shows frequency or time on a 7-segment fluorescent readout along with a channel and mode display, plus a digital signal strength meter. A special feature is the tuning knob, which is an index switch, but the unit can also be tuned using UP and DOWN channel-step keys. The FRG-9600 can be optionally computer controlled via Yaesu's CAT interface system. It operates from a nominal 13.8 V supply and may be bench (base) or vehicle (mobile) mounted.

All you have to do is complete the questions below and tell us in 30 words or less what it is about the Yaesu FRG-9600 scanner that attracts you.

☆ **PRIZE WORTH \$729** ☆



**Send your entry to:**  
**YAESU FRG-9600 SCANNER CONTEST**  
 Australian Electronics Monthly  
 PO Box 289, Wahroonga NSW 2076

You may enter as many times as you wish, but you must use a separate entry form for each entry and include a month and page number cut from the bottom of this page. You must put your name and address on the entry form and sign it where indicated. That is, photocopies are acceptable but an original month/page number from a copy of this month's magazine must accompany each entry form. Please read the contest rules carefully, especially if sending multiple entries.

The winning entry will be drawn by the Editor, whose decision is final, no correspondence will be entered into regarding the decision.

Winners will be notified by telegram the day the results are declared and the winner's name and contest results published in the next possible issue of the magazine.

**RULES** Contestants must enter their names and addresses where indicated on each entry form. Photostats or clearly written copies will be accepted, but if sending copies you must cut out and include with each entry an original page number and month cut from the bottom of the page of the contest. This contest is invalid in states where local laws prohibit entries. Entrants must sign the declaration, accompanying the contest, that they have read the above rules and agree to abide by their conditions.

**CLOSING DATE OF THE CONTEST** is the last mail of January 31, 1986. Entries received within seven days of that date will be accepted if postmarked prior to and including the date.

- Q1: What reception facility is unique to the Yaesu FRG-9600?  
 A1: .....
- Q2: Does the FRG-9600 employ triple or double conversion, or both?  
 A2: .....
- Q3: Who first imported Yaesu equipment into Australia in the early 1960s?  
 A3: .....
- Q4: About how long has Dick Smith Electronics been selling Yaesu equipment?  
 A4: .....
- Q5: What is the minimum tuning step of the FRG-9600 and in what mode?  
 A5: .....

Now tell us in 30 words or less what it is about the FRG-9600 that attracts you:

.....  
 .....  
 .....  
 .....  
 .....  
 Name .....  
 Address .....  
 .....  
 Postcode .....

I have read the rules of the contest and agree to abide by their conditions:  
 Signed .....

good enough to allow us to understand why it varies from day to day, except in a general hand-waving sense in which we attribute the changes to changes in the flux of EUV radiation from active regions on the sun, to changes in the neutral winds blowing in the atmosphere, and to changes in the electric currents flowing in the ionosphere. Because of this and because in practical HF communications it's usually not necessary to worry too much about such details, we can ignore the day-to-day variations to a large extent and work in terms of the average behaviour of the ionosphere for the month, at each of the 24 hours of the day.

In a 31-day month, there will be 31 observations of foF2, say, at a particular hour. A very good representative value of these 31 observations is the value which is exceeded on 15 days, and which itself exceeds the values observed on the other 15 days. This is called the median value. We would also like some estimate of the range of observed values about the median. If the median is 10 MHz and the individual values range from 5 to 20 MHz, the median does not tell us very much since the range covers most of the HF band. If, however, the range is from 8 to 12 MHz, we can never be more than 2 MHz out if we take 10 MHz as the value of foF2 for every day of the month at the hour considered.

In practice, we represent the range of values by the third lowest and third highest values. The third lowest value is exceeded on 28 days or approximately 90% of the month, while the third highest value exceeds the other observations for 90% of the month\*.

The value exceeded for 90% of the month is called the lower decile (lowest 10%), while the value exceeded for 10% of the month is called the upper decile. In the same sense, the median is the 50% decile.

Table 4.2 illustrates how the median and decile values are deduced for one set of foF2 observations. This set of observations is just one of the 24 sets of observations for Canberra, Australia, for midnight in December 1980. Figure 4.6 shows the complete 24 x 31 observations, with the values of the median and deciles at each hour. The diurnal and seasonal variations illustrated earlier in Figures 4.4 and 4.5 in fact correspond to median values of the critical frequencies. Figure 4.6 also shows that on some days foF2 is much lower than on the remaining days. These are called disturbed days and happen when the sun becomes disturbed, as we

Upper decile, median and lower decile

87	71	91	91	84	94	89	89	84	89
86	87	72	86	79	86	72	79	92	43
43	87	84	87	90	94	82	80	90	80
92									

31 daily values of foF2 recorded at midnight in Canberra in December 1980. Frequency unit = 100 kHz.

94	94	92	91	91	91	90	90	89	89
89	87	87	87	87	86	86	86	84	84
84	82	80	80	79	79	72	72	71	43
43									

Same set of foF2 values rearranged in order of decreasing value.

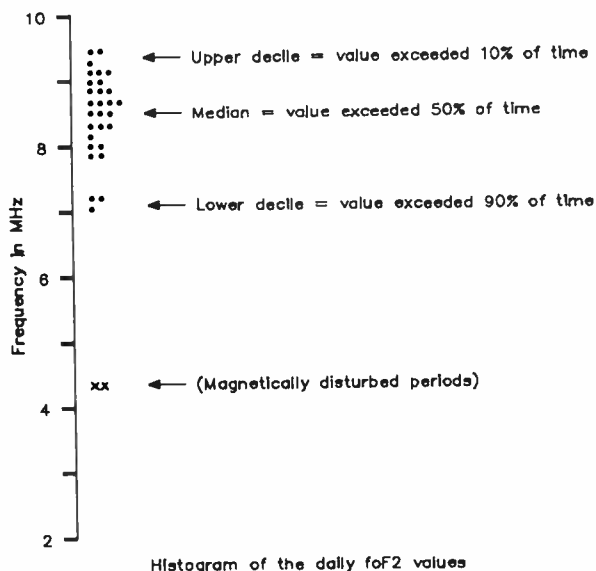


TABLE 4.2:

The decile and median values of the 31 values of foF2 observed at Canberra in December 1980. The data are first arranged in decreasing order. The values exceeded on 3 days (upper decile), 15 days (median) and 27 days (lower decile) are then determined by counting through the ordered array of values.

shall see in a later part.

The use of this statistical description of the ionosphere reduces from 31 to three the number of parameters (or quantities) necessary to describe the behaviour of the ionosphere at a given hour of a given month at a given location. This 10-fold decrease is a very useful reduction in the enormous amount of data required to describe the ionosphere and all its variations.

— continued next month

\*We will not worry about the details of what happens when several values are equal, or when there are 30 days in the month. The ideas are the same.

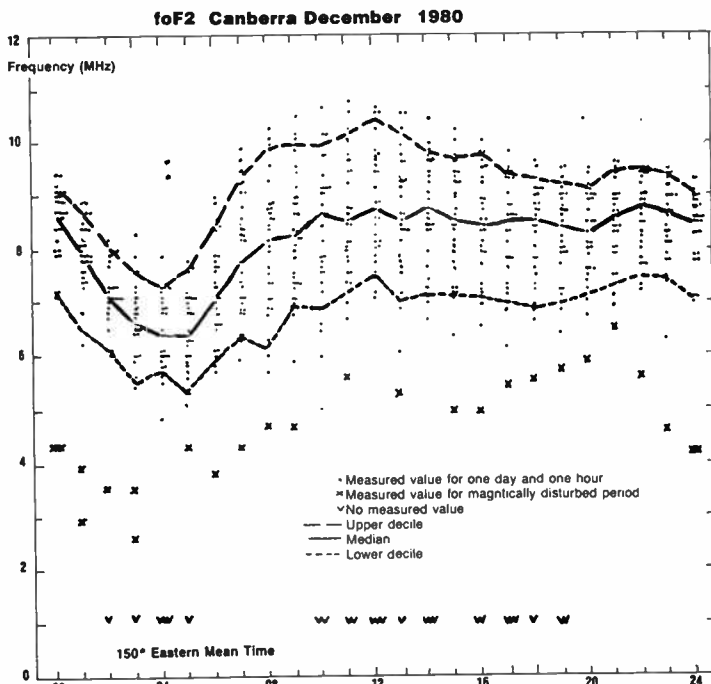


Figure 4.6. The variability of foF2 at a typical mid-latitude station, Canberra, for December, 1980. There are 31 observations at each hour, except for the occasional equipment failure. The solid curve is the median curve — at each hour, 15 points lie above this line while 15 points lie below it (or on the line). The upper dashed curve is the upper decile curve, and there are three points (10% of 31) lying above the curve, corresponding to the highest three observed values of foF2. The lower dashed curve is the lower decile curve, and there are three points lying below it.



## TEST INSTRUMENT CENTRE

FOR YOUR LABORATORY — WORKSHOP — HAM RADIO SHACK — HOBBY — WE STOCK FAMOUS BRANDS:

- OSCILLOSCOPES • FREQ. COUNTERS • DIGITAL & ANALOG MULTIMETERS • LCR METERS • SWR & RF POWER METERS • PANEL METERS, etc.

**KIKUSUI COS5020-20MHZ** 2CH DUAL TRACE



Sensitivity: 5mV/div-5V/div,  
1mV/div at x5 MAG.  
Bandwidth: DC or 10Hz-20MHz.  
Sweep Speed: 0.2 μs-5s/div.  
Sweep Mode: AUTO, NOFM, SINGLE

Trigger Source: CH1, CH2, LINE, EXT.  
X-Y Operation, CHOP and TV.  
CRT: 6-inch rectangular.  
Z-axis CH1 Output.



## RADIO COMMUNICATION CENTRE

SCAN AUSTRALIA  
WITH THE WORLD'S BEST  
SCANNING RECEIVER

# AR-2002

SCAN AUSTRALIA WITH THE BEST!



- FEATURES:**
- 25-550MHz, 800-1300MHz (UHF TV CHANNELS 550-800MHz EXCLUDED)
  - NBFM-WBFM-AM MODES • 20 CH MEMORY
  - CLOCK • PRIORITY CH • S-METER
  - MANY OTHER FEATURES

Send for colour brochure



## NEW Personal 2-way radio here at last! "EMTRON ACE"

- A QUALITY 40 CH HIGH POWER UHF CB HAND HELD TRANSCIVER
- DESIGNED FOR AUSTRALIA OOC APPROVED

### FEATURES:

- 40 CHANNEL OPERATION
- HIGH (20W) LOW (0.5W) RF OUTPUT
- OFFSET FOR REPEATER OPERATION
- RECHARGEABLE BATTERIES
- ILLUMINATED DIAL FOR NIGHT OPERATION
- SMALL IN SIZE BIG IN PERFORMANCE

### APPLICATIONS:

- FARMING
- FISHING BOATING HUNTING BUSHWALKING
- BUSH FIRE CONTROL
- AG SHOWS
- SECURITY
- CONSTRUCTION SITES
- CAR RALLIES
- CROWD CONTROL AND MANY OTHERS

### OPTIONS:

- 3W MICAO
- SP MIKE
- 1/4 WHIP
- STAND IN CHARGER
- DRY CELL PACK
- DC/DC CONVERTER AND MANY MORE

**DEALER INQUIRIES WELCOME**



# EMTRONICS

Retail Division of EMONA ELECTRONICS P L

NSW STORE & HEAD OFFICE:  
92-94 Wentworth Ave, Sydney, NSW, 2000  
Ph: (02) 211 0988. Telex: AA73990 (EMOLEC)

VIC STORE:  
288-294 Queen St, Melbourne, Vic. 3000  
Entrance from Little Lonsdale St.  
Ph: (03) 67 8551 or 67 8181

Correspondence & Mail Orders: Box K21, Haymarket, NSW, 2000

# The AUSTRALIAN ELECTRONICS Monthly

## PC BOARD SERVICE

If your local retailer or board manufacturer is unable to supply you an AEM board, we are carrying a limited number of rolled-tin over copper circuit boards complete with silk screen component over-lay.

Project	Retail Price
1500 Metronome	\$ 4.67
3500 Listening Post	\$ 8.06
6500 Universal Mosfet Amp Module	\$ 9.69
9500 Beat-triggered Strobe	\$11.32
6102 2-Way Speaker	\$21.75
5501 Negative Ion Generator	\$12.35
4500 Microtrainer	\$28.47
6510 4-Input Mixer	\$20.40
6010LL	\$19.06
6010MA	\$23.10
6010F	\$16.37
6010R	\$16.37
Set of 4	\$74.90
4501 8 Channel Computer Relay Interface	\$13.00
6502 Order 6500 and 6501	
8500 Courtesy Light Extender	\$ 9.92
4502 Real Time Clock	\$10.46
4600 Oval-Speed Modem	\$22.42
5502 Microwave Oven Leak Detector	\$ 9.12
2500 Sine/Square Audio Signal Generator	\$ 9.65

Note: The boards found in this issue are also available, price on application

Please rush me the following boards

Project No. \_\_\_\_\_ Price \_\_\_\_\_  
S \_\_\_\_\_

Allow a minimum of 4 weeks delivery  
Price includes postage & packing  
New Zealand, add \$1.00 to these charges

All cheques or money orders should be made payable to Australian Electronics Monthly

Name \_\_\_\_\_

Address \_\_\_\_\_

Postcode \_\_\_\_\_

I enclose my cheque/money order for \_\_\_\_\_

Please tick payment method

Cheque/money order  Bankcard  Visa

Mastercard  American Express

Card No. \_\_\_\_\_ Expiration \_\_\_\_\_

Signature \_\_\_\_\_

((Note: Unsigned credit card orders cannot be accepted))

You can buy the boards at our offices if you wish, at any time during business hours. We're located at WB Building, Cnr Fox Valley Rd and Kiole St, Wahroonga NSW, the entrance is in Kiole St.

## BWD's Powerscope II caters for every industry

**E**lectronics grew up as an isolated, specialist industry, but today it has penetrated into — and is an integral part of — virtually every industry, from boilermaking to zookeeping.

Numerical control machines and robotics, power generation, transport and earth moving, all employ electronics in some form, so BWD designed the 'Powerscope II' as a multi-industry test instrument.

It is claimed to be the only instrument in the world that will simply, safely and accurately display multiple in-circuit power control measurements — voltage, current, power, phase and time — up to 1000 volts, while also providing normal oscilloscope functions.

The original Powerscope has already made an impact on world markets, with thousands in use. The new Powerscope II has greatly expanded versatility and specifications, with its capacity to provide precise visual display of waveforms as-

sociated with ac and dc power engineering.

Its advantage compared with general purpose oscilloscopes, BWD say, is the ability to display simultaneously four completely independent signals with levels from 20 mV to 2 kV from equipment operating directly in single or multi-phase power lines or at high dc levels. It can also handle digital or analogue signals to 50 MHz through its 5th channel. No other oscilloscope on the market today can do all this with the high degree of safety offered, according to BWD.

Special attention has been given to reducing any possible shock hazard. The panel, knobs and input sockets are deeply recessed and the probes are designed especially to provide



safe connection to power lines and direct in-line equipment.

A four channel output plus four individual channel outputs are available for connection to any storage oscilloscope, distortion analyser, pen recorder, tape recorder or multimeter.

In the field of Robotics and NC Machinery the Powerscope II will simultaneously measure three plane XYZ, plus time signals of robotic controllers. Response times of input signals to output movement of controls are easily catered for.

The transport and mining industries are other important areas where its applications include the monitoring, testing, designing or commissioning of traction motors in transport systems, rail, electric cars, cranes etc.

The computer industry also benefits. The Powerscope II can be used to fault-find single and 3-phase switchmode power supplies and present 4-channel digital/analogue signals with fifth channel triggering.

The 'phase marker' facility, unique to the Powerscope II says BWD, provides a means of accurately measuring phase angles from a known reference point in single or multi-phase power systems.

The Powerscope II is both a laboratory and portable instrument, and can be operated on normal ac power or any dc source, including rechargeable batteries.

Further information from **BWD Industries Ltd, 5-7 Dunlop Road, Mulgrave 3170 Vic. (03) 561 2888.**

### British connections

**W**e hear from Elmeasco of two ranges of products released by Coline Ltd of the U.K. Firstly, their connectors: this range, numbering more than thirty, includes BNC plug and adaptors, elbow plugs, tee adaptors, BNC jacks, panel and bulkhead sockets, UHF plugs and sockets, type N plugs and jacks.

These are manufactured to conform to the relevant MIL, IEC and DEC standards. The bodies are made of brass, finished in bright nickel plate, while contacts are berillium copper or brass finished in bright silver plate. Gaskets are silicone rubber and insulation is PTFE.

Coline also announced the LTL1000 Test Lead Set. The leads feature a unique method of connection to the measuring instrument. After insertion of the plug, a locking screw is

tightened, causing the contact to expand inside the instrument socket thus providing a secure and reliable connection with a reduction in unwanted thermal EMFs and very low contact resistance.

The leads are flexible copper conductors with a tough silicone rubber insulation and are provided with prods which have a threaded section to permit the addition of various accessories.

The LTL1000S is similar to the LTL1000 but includes shrouds over the 4 mm plugs to fit instruments with recessed sockets.

Elmeasco also inform us that their Adelaide branch has moved to larger premises with more convenient parking facilities. The new address is 241 Churchill Road, Prospect, 5082 SA. (08) 344 9000.

The Elmeasco Sydney office is still at 15 McDonald Street, Mortlake. (02) 736 2888.

### New microswitches from Burgess

**P**lay the usual word association game with many an electronics person and on saying "microswitch" you probably will hear the reply "Burgess".

This English firm, represented in Australia by **Email Limited Relays Division at Artarmon, NSW and Huntingdale, Victoria**, has announced a new low profile microswitch for pc mounting, available in

single- and double-pole versions, and said to be only one-third the height of comparable units.

The LDSP single-pole and LPDP double-pole microswitches are under 8 mm high and measure 19 x 7 mm and 19 x 14 mm respectively. Both are capable of switching voltages up to 250 V ac or dc.

Actuators can be fitted at either end, and single-throw or changeover options can be supplied with either sequenced or non-sequenced operation. Terminals are pitched on the international standard 0.1" matrix.

### Major UK defence contract for Phillips

Philips Test and Measurement at Pye Unicam, Cambridge, UK, has been awarded a Ministry of Defence contract to supply more than 3700 oscilloscopes over a period of three-and-a-half years.

The contract — one of the largest ever awarded to Philips Test and Measurement in Europe, is for PM 3217 50 MHz general-purpose oscilloscopes. They will be used by the three British armed services.

# JAYCAR MASSIVE KIT WAREHOUSE CLEARANCE - WE'RE DREADFULLY OVERSTOCKED ON MANY KIT LINES & HAVE NO ROOM FOR THE GREAT NEW RANGE PLANNED FOR 1986. RUSH IN NOW FOR THE BARGAIN OF A LIFETIME!

## NEW Video Fader

Ref. EA January 1986  
Fades video signal to black and un again without loss of sync. PCB project. Plugpack and box extra.  
Cat. KA 1626

**ONLY \$19.95**



## Hands-Free Telephone Adaptor

Ref. EA November 1985  
Jaycar now has stocks of this superbly designed project. Call in and check it out now! Note: this unit is ORIGINAL to the design.  
Cat. KA 1640

**ONLY \$79.00**



## NEW KITS FROM "AUSTRALIAN ELECTRONICS MONTHLY" AEM 6010 Ultra Fidelity Preamp

Ref. AEM Oct. Nov 1985

We now have stocks of this project in kit form including the original case, components etc. Nothing else to buy! Chassis is pre-punched with original front panel.  
Cat. KM 3030

**ONLY \$269.00**

## AEM 4600 Dual Speed Modem

Ref. AEM December 1985

This is the ultimate kit modem. Dual 1200/300 Baud. case etc all included.  
Cat. KM 3040

**ONLY \$169.00**



★★★ SPECIAL FULLY IMPORTED 'POWERTRAN' MIDI-CONTROLLED SAMPLER - see review in August 1985 Sonics  
KIT VERSION **\$800**  
BUILT VERSION **\$1,000**  
UNDER 1/2 PRICE

## OTHER KIT BARGAINS Save up to 50%

Cat. KJ 6602  
CLEF™ (UK) MICROSYNTH KEYBOARD SYNTHESIZER COMPLETE KIT  
**WAS \$399 SAVE 50%**  
**NOW \$199.00**

Cat. KJ 6652  
SPARKRITE™ TX 2002 ELECTRONIC IGNITION  
**WAS \$129.00 SAVE 24%**  
**NOW \$99.00**

Cat. KS 8117  
HOUSE AND CAR ALARM KIT  
**WAS \$19.95 SAVE 50%**  
**NOW \$9.95**

Cat. KS 8123  
ALIEN INVADERS KIT  
**WAS \$15.50 SAVE 50%**  
**NOW \$7.95**



## 8 SECTOR BURGLAR ALARM

Ref. EA Jan/Feb 1985

Why buy a commercially made up unit for more when you can buy this kit and SAVE money! A unique feature of this kit is the fact that you can wire N/O and N/C alarm sensors ON THE SAME LINE.  
★ 8 SECTORS ★ 2 delayed entry sensors ★ steel box ★ includes battery and siren driver in the price ★ variable exit and entry delays.  
Cat. KA 1580

**ONLY \$149.00**

## AEM 3500 'The Listening Post'

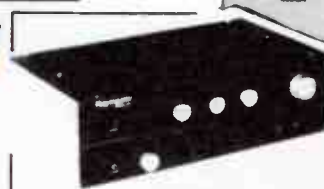
Ref. July 1985

Decode all that info on your short wave radio to show Morse code, RTTY, weather maps etc. Wonderful!!! (A personal computer is required).  
Cat. KM 3015

**ONLY \$29.50**



MAIL ORDER HOTLINE  
(02) 747 1888



## PLAYMASTER SERIES II MOSPET AMP KIT

Ref. EA Jan/Feb/March 1985  
... stereo amplifier that will equal or better just about any integrated commercial amplifier, regardless of price. Leo Simpson, Editor of EA, February 1985.

### MAIN FEATURES

- Switchable phono input for MM and MC cartridges
- Electronic signal switching
- Full facilities for dubbing between two cassette decks
- Monitor loop for either of two cassette decks or a signal processor
- Click action pushbutton switches for selection of sources, dubbing and tape monitor with LED status indicators
- Centre detents on bass, treble and balance controls, multiple detents on volume control
- Heavy duty heatsinks
- Power transformer for low hum and noise
- Easy to build - all parts except power supply mount directly on the two printed circuit boards. Wiring has been kept to an absolute minimum
- 100 watts RMS per channel into 8 ohm load
- Less than 0.01% total harmonic distortion

Cat. KA-1500

**ONLY \$429.00**

## GRAPHIC EQUALISERS UNBEATABLE BARGAINS 2010 MKIIA

The 2010 is a one control per octave equaliser. This gives you tremendous room for equalisation. There are separate controls for right and left channels plus there is a multifunction control pushbutton. A superb kit which is supplied with a pre-punched 88mm (2 rack unit) cabinet which matches other ETI 5000 system components.

**NORMALLY \$135**  
**SAVE \$36 or 26%**  
**JAN SPECIAL \$99**

## 2801 1/2 OCTAVE UNIT

The 2801 comes with a complete fused power supply for 240V AC operation. It is also fitted with standard Cannon Male/Female chassis connectors for professional ease of use. It is output short circuit proof and will drive very long unbalanced lines without degradation. Naturally it comes in a rugged 19" road quality rack cabinet - ANOTHER SUPERB KIT FROM JAYCAR

**NORMALLY \$225**  
**SAVE \$50**  
**JAN SPECIAL \$175**



# JAYCAR NO1 KITS





## EA KIT BARGAINS

Save up to 43%

Cat KA 1055  
SUPER SIREN (FULL KIT)  
Ref EA November 1982  
**WAS \$19.95 SAVE 25%**  
**NOW \$14.95**

Cat KA 1484  
SUPER SIREN (SHORT FORM)  
Ref EA November 1982  
**WAS \$8.50 SAVE 41%**  
**NOW \$5.00**

Cat KA 1118  
VIDEO ENHANCER  
Ref EA October 1983  
**WAS \$39.50 SAVE 25%**  
**NOW \$29.50**

Cat KA 1478  
STEREO SYNTHESISER (FULL KIT)  
Ref EA December 1982  
**WAS \$59 SAVE 20%**  
**NOW \$47.00**

Cat KA 1476  
STEREO SYNTHESISER (SHORT FORM)  
Ref EA September 1982  
**WAS \$43.50 SAVE 25%**  
**NOW \$32.50**

Cat KA 1492  
pH METER LCD  
(Meter only not probe)  
Ref EA December 1982  
**WAS \$79 SAVE 24%**  
**NOW \$60.00**

Cat KA 1520  
3.50 VOLT POWER SUPPLY  
Ref EA May/June 1983  
**WAS \$179 SAVE 16%**  
**NOW \$149.00**

Cat KA 1547  
EA DIGITAL FREQUENCY COUNTER  
ADD ON  
**WAS \$17.50 SAVE 43%**  
**NOW \$10.00**

Cat KA 1557  
EPROM COPIER  
Ref EA December 1984  
**WAS \$75.00 SAVE 35%**  
**NOW \$49.00**

Cat KA 1558  
UNIVERSAL MOTOR SPEED CONTROLLER  
Ref EA December 1984  
**WAS \$24.95 SAVE 20%**  
**NOW \$19.95**

Cat KA 1564  
BRAKE LAMP FLASHER  
**WAS \$16.50 SAVE 22%**  
**NOW \$12.95**

Cat KA 1592  
BUSKER AMPLIFIER  
**WAS \$125 SAVE 20%**  
**NOW \$99.00**

Cat KA 1593  
WOODEN CABINET FOR BUSKER  
**WAS \$30.00 SAVE 33 1/3%**  
**NOW \$20.00**

## ★ NEW ★ NEW ★ ELECTRIC FENCE CONTROLLER

Ref EA December 1985  
High power and lower current drain. No auto coil needed. Compact and all parts included.  
Cat KA 1660

**ONLY \$45.00**

## WARNING! ELECTRIC FENCE

ELECTRONICS  
AUSTRALIA

## AEM 6103 10" 3-WAY SPEAKER SYSTEM

Ref AEM January 1986

- ★ WE HAVE THE SPEAKERS
- ★ WE HAVE THE CROSSOVERS
- ★ WE WILL HAVE THE CABINETS CALL IN!



## ETI KIT BARGAINS

Save up to 42%

Cat KE-4554  
ETI 760 VIDEO MODULATOR  
**WAS \$23.50 SAVE 28%**  
**NOW \$16.95**

Cat KE-4654  
ETI 733 RTTY CONVERTER  
**WAS \$24.95 SAVE 28%**  
**NOW \$17.95**

Cat KE-4570  
ETI 162 1A/30V ADJUSTABLE  
POWER SUPPLY  
**WAS \$65.00 SAVE 23%**  
**NOW \$49.95**

Cat KE-4671  
PARALLEL INTERFACE KIT  
FOR MICROBEE  
**WAS \$15.95 SAVE 22%**  
**NOW \$12.50**

Cat KE-4683  
"MASTERPLAY" AMPLIFIER  
(turntable extra)  
**WAS \$69.95 SAVE 29%**  
**NOW \$49.95**

Cat KE-4696  
MICROBEE DIALLER  
**WAS \$23.95 SAVE 42%**  
**NOW \$13.95**

Cat KE-4700  
ETI 1404 4 INPUT MIXER  
**WAS \$99.00 SAVE 20%**  
**NOW \$79.00**

Cat KE-4703  
ETI 341 ELECTRONIC JUMPER LEADS  
**WAS \$39.95 SAVE 20%**  
**NOW \$31.95**

## BEGINNERS KITS

Save up to 53%

Cat KE-4000  
ETI 048 BUZZ BOARD  
**WAS \$8.50 SAVE 53%**  
**NOW \$4.00**

Cat KE-4001  
ETI 061 BASIC AMP KIT  
**WAS \$8.90 SAVE 45%**  
**NOW \$4.90**

Cat KE-4002  
ETI 065 ELECTRONIC SIREN  
**WAS \$8.90 SAVE 45%**  
**NOW \$4.90**

Cat KE-4003  
ETI 068 LED DICE  
**WAS \$8.90 SAVE 45%**  
**NOW \$4.90**

Join the Compact Disc  
Owners Club - ring (02)  
747 1888 or call in to  
one of our stores for  
details.

## ☆☆ NEW ☆☆ 300 WATT INVERTER WITH AUTO START

NOT A KIT - BUILT, TESTED &  
GUARANTEED

This is the built version of the "Electronics Australia September 1985 project". Just think how handy it would be to have 240volts AC mains power when camping, or for your boat or caravan - well this brilliant new design is the answer. Super compact - tough ABS case. Uses high efficiency toroid transformer which keeps the weight down, battery drain and heat dissipation. Auto start draws power from your battery on when appliance is plugged in and turned on - i.e. battery can be left permanently connected. Thermal overload automatically shuts down if/when output stage is overheated (through high ambient temperature and high load or combination thereof - automatic reset. Current regulated inverter ensures the unit is being used within designed overload limits. Current overload unit self limits - LED indicates overload condition.

COMPLETE KIT VERSION

Cat KA 1610  
**ONLY \$199.00**  
FULLY BUILT & TESTED

Cat MI 5000  
**ONLY \$249.00**



MAIL ORDER HOTLINE  
(02) 747 1888

## ☆☆ NEW ☆☆ Motor/Gearbox Kit

This fantastic new kit enables you to produce a shaft speed between 3 and 2,000 RPM! It uses a small DC motor with a modular gearbox attached. You are supplied with gear wheels, spacers etc to configure your gearbox to almost any speed within the 3-2,000 RPM range. Measures only 48(H) x 25(W) x 37(D)mm (not including output shaft).  
Cat YX 2600

**ONLY \$14.95**

## Bench Type Digital Capacitance Meter

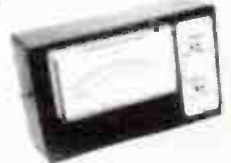
Ref EA August 1985 - measure from 1pF to 99.9uF with this handy piece of equipment.  
Cat KA 1595

**ONLY \$79.95**

## DWELL/TACHOMETER

Ref EA Sept 1985  
Tune up your car quickly and easily with this handy piece of gear. The Jaycar kit includes case, large meter and Scotchcal meterscale.  
Cat KA 1612

**ONLY \$34.95**  
Suits 4-6 or 8 cylinder cars



# Jaycar ELECTRONICS

Incorporating ELECTRONIC AGENCIES

Carlingford Hurstville Gore Hill Brisbane Mon-Fri 9am - 5:30pm  
Sydney and Concord Mon-Fri 8:30am - 5:30pm  
Sydney Carlingford Hurstville Thursday nights until 8:30pm  
Brisbane Thursday night until 8pm  
Sydney Carlingford Hurstville Brisbane Saturdays 9am - 12 noon  
Gore Hill Saturday 9am - 4pm

CONCORD NOT OPEN ON SATURDAYS

**NUMBER 1 FOR KITS**

NEW  
SHOWROOMS

QUEENSLAND  
MAIL ORDER  
HEAD OFFICE

SYDNEY: 117 York Street Tel (02) 267 1614  
CARLINGFORD: Cnr Carlingford & Pennant Hills Road Tel (02) 872 4444  
CONCORD: 115/117 Parramatta Road Tel (02) 745 3077  
HURSTVILLE: 121 Forest Road Tel (02) 570 7000  
GORE HILL: 188/192 Pacific Highway (Cnr Bellevue Avenue) Tel (02) 439 4799  
BRANDS: 144 Logan Road Tel (07) 393 0777  
P.O. Box 185, CONCORD 2137  
115-117 Parramatta Road, CONCORD 2137  
Tel (02) 747 2022 Telex: 72293

POST & PACKING

\$5 - \$9.99	\$2.00
\$10 - \$24.99	\$3.75
\$25 - \$49.99	\$4.50
\$50 - \$99.99	\$6.50
\$100 - \$198	\$8.00
Over \$199	\$10.00

COMET ROAD FREIGHT ANYWHERE IN AUSTRALIA ONLY \$15.00



MAIL ORDER VIA  
YOUR PHONE



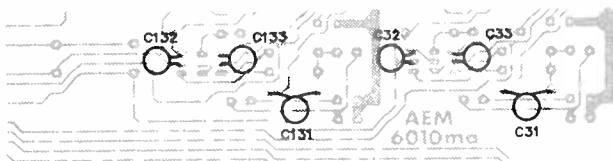
# NOTES & ERRATA

**V8 — the new 8 mm video tape technology, Nov. '85.** The table on page 27 showing comparison of 8 mm video and current home VCR formats contains an error on the line dealing with "Head-to-tape speed". The speed is actually metres/sec, not mm/sec.

**Meet Elami Jr, AEM Product Review, Dec. '85, p. 33.** The last two lines went missing. Here they are: "Review unit kindly supplied by Captain Communications, 28 Park St, Parramatta, NSW. (02) 633 4007. Recommended retail price \$199.00" Apologies to everyone for the omission.

**Project 6010 An 'ultra-fidelity' preamplifier, Part 2. Nov. '85.** There is a missing track on the 6010ma pc board which should link the emitter of Q128 to the common of resistors R171, R175, R176. The circuit diagram is correct. Fortunately, the missing track will only marginally affect the right channel's input noise performance. The various pc board makers have been issued new artwork.

**Project 6010 An 'ultra-fidelity' preamplifier, Part 3. Dec. '85.** In the diagram on the bottom of page 51, showing the placement of the capacitors on the rear of the 6010ma board, the printers misplaced the pc board track overlay. Here's what they meant to print —



**Project 4600 'Dual-Speed' modem. Dec. '85.** Under "circuit operation" on page 82, second column, third-last paragraph, the explanation as to which channels are used to transmit and receive in 1200/75 mode has suffered transposition in typesetting. Even the proofreader got confused! The last sentence of this paragraph should read: "Conversely, if we were receiving at 75 Baud and transmitting at 1200 Baud, this time we'd be using the main channel to transmit the data and the back channel to receive the data."

A short length of tape went missing from the board artwork, also, preventing transmission on 300 Bauds. Contact 'b' on SW2 should go to the junction of R7/R8. Just link 'b' on SW2 to '6' on SW4. A small number of initial boards were affected.

## The AUSTRALIAN ELECTRONICS Monthly

### PC BOARD SERVICE

If your local retailer or board manufacturer is unable to supply you an AEM board, we are carrying a limited number of rolled-tin over copper circuit boards complete with silk screen component over-lay.

Project	Retail Price
1500 Metronome	\$ 4 67
3500 Listening Post	\$ 8 06
6500 Universal Mosfet Amp Module	\$ 9 69
9500 Beat-triggered Strobe	\$11 32
6102 2-Way Speaker	\$21 75
5501 Negative Ion Generator	\$12 35
4500 Microtrainer	\$28 47
6510 4-Input Mixer	\$20 40
6010LL	\$19 06
6010MA	\$23 10
6010F	\$16 37
6010R	\$16 37
Set of 4	\$74 90
4501 8 Channel Computer Relay Interface	\$13 00
6502 Order 6500 and 6501	
8500 Courtesy Light Extender	\$ 9 92
4502 Real Time Clock	\$10 46
4600 Dual-Speed Modem	\$22 42
5502 Microwave Oven leak Detector	\$ 9 12
2500 Sine/Square Audio Signal Generator	\$ 9 65

Note: The boards found in this issue are also available. price on application

Please rush me the following boards

Project No. Price  
\$

Allow a minimum of 4 weeks delivery  
Price includes postage & packing  
New Zealand, add \$1.00 to these charges

All cheques or money orders should be made payable to  
Australian Electronics Monthly

Name .....

Address .....

Postcode .....

I enclose my cheque/money order for .....

Please tick payment method

Cheque/money order  Bankcard  Visa

Mastercard  American Express

Card No ..... Expiration .....

Signature .....

((Note: Unsigned credit card orders cannot be accepted))

You can buy the boards at our offices if you wish, at any time during business hours. We're located at WB Building, Cnr Fox Valley Rd and Kioogle St, Wahroonga NSW, the entrance is in Kioogle St.

# aem project 6103

from p. 53.

## PARTS LIST AEM6103

**Crossover components**  
(only required if pre-assembled unit will not be employed)

**Resistors** all 5W, 10%  
R1 ..... 15R  
R2 ..... 4R7  
R3 ..... 6R8  
R4 ..... 3R9  
R5 ..... 8R2

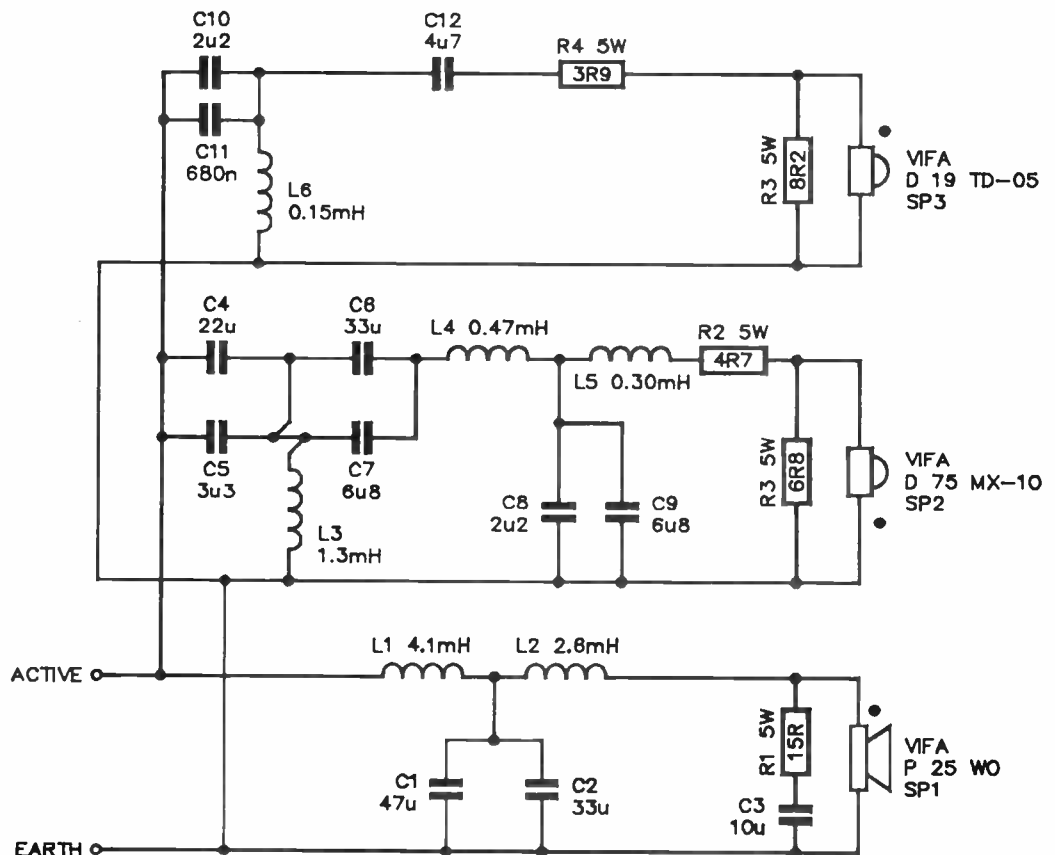
**Capacitors**  
C1 ..... 47u bipolar  
C2 ..... 33u bipolar  
C3 ..... 10u bipolar  
C4 ..... 22u bipolar  
C5 ..... 3u3 greencap  
C6 ..... 33u bipolar  
C7 ..... 6u8 greencap  
C8 ..... 2u2 greencap  
C9 ..... 6u8 greencap  
C10 ..... 2u2 greencap  
C11 ..... 680n greencap  
C12 ..... 4u7 greencap

**Inductors**  
L1 ..... 4.1 mH, < 0.8 ohm  
L2 ..... 2.6 mH, < 0.6 ohm  
L3 ..... 1.3 mH, < 0.5 ohm  
L4 ..... 0.47 mH, < 0.5 ohm  
L5 ..... 0.3 mH, < 0.5 ohm  
L6 ..... 0.15 mH, < 0.5 ohm

**Drivers**  
SP1 ..... Vifa P25WO  
SP2 ..... Vifa D75MX-10  
SP3 ..... D19TD-05

**Miscellaneous**  
AEM6103 three-way bass-reflex enclosure (see text); length of PVC irrigation pipe (see text); loud-speaker terminal block and mounting screws (see text); medium density mattress overlay foam — 25 mm and 50 mm thickness; speaker mounting hardware; several metres of heavy gauge 'figure 8' cable; 'Silastic' or similar silicone sealant.

**Expected cost: \$550 - \$800**  
depending on crossover and boxes and quality of components purchased.



CROSSOVER POINTS—500Hz AND 4.3kHz ● 18dB/OCTAVE  
M—DERIVED (M=0.6)

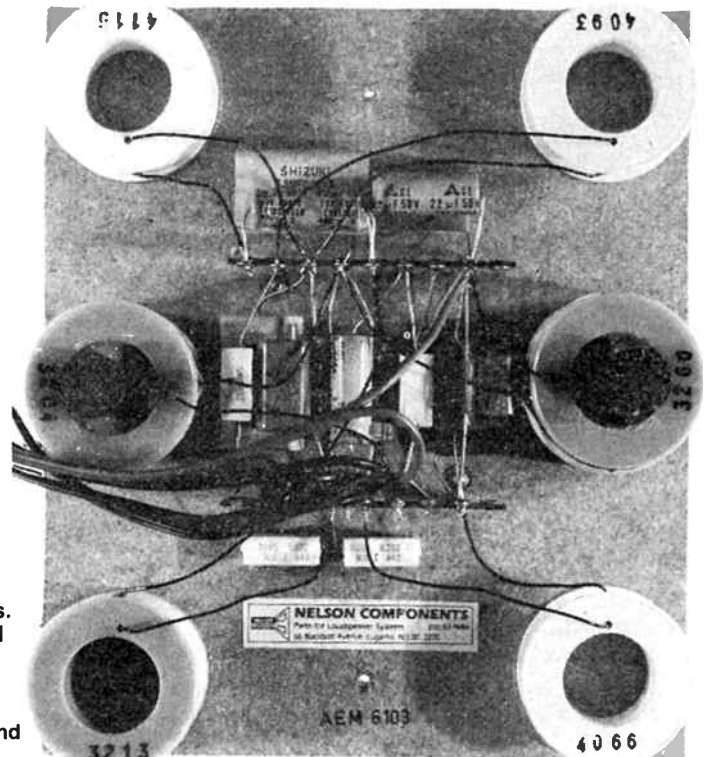
AEM6103 three-way loudspeaker.

## SPECIFICATIONS AEM6103

Enclosure type ..... bass reflex  
Frequency response ..... 30 Hz-18 kHz, +/-3 dB\*  
Crossover points ..... 500 Hz and 4.3 kHz  
Crossover type ..... 3rd-order, maximally flat  
Nominal power handling ..... 80 W RMS (DIN 45573)

\*Measured on prototype, 1 m on tweeter axis, in room

The ready-assembled crossover from Nelson Components. All the wires to the speakers are individually colour-coded with identifying stripe on the 'active' lead. Two of the inductors use ferrite 'slugs' to achieve the required inductance on a practical-sized former. These slugs are made of special audio ferrite, manufactured by Neosid, and are employed by KEF in crossover inductors for their speakers.



For those diehards who wish to wind their own coils and assemble the crossover themselves, complete component specifications are given in the accompanying parts list. For the coils, an appropriate wire gauge to give no more than the required maximum resistance should be used. A construction method similar to the pre-assembled unit shown here could be adopted. Pre-wound coils may be available from some suppliers, or you could enquire from Nelson Components.

Once the crossover construction is complete, it should be positioned approximately in the box so that the required lengths of wire from the crossover to the various drivers can be determined. Cut the wires to the appropriate length and solder one end to the crossover (N.B. This step will not be necessary if the pre-built crossover is used). The crossover can then be mounted in place by screwing it to the rear panel inside the loudspeaker box. This can be a little difficult and I found it easiest to locate the crossover as closely as possible to the bass unit hole i.e. so that the crossover to the speaker input terminals, mounted on the cabinet rear.

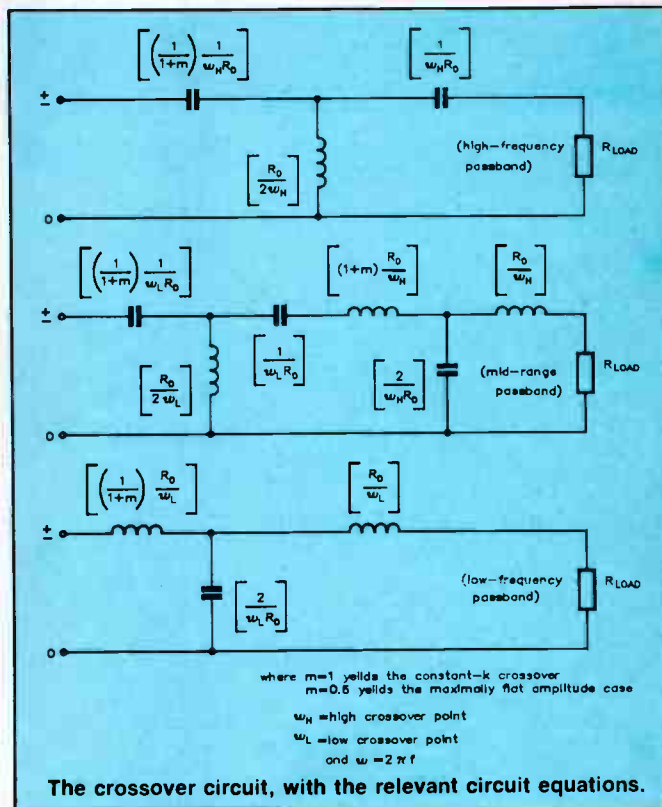
Once the crossover is mounted in place the box should be lined with the mattress overlay foam. You will need to cut a hole in the foam through which to pass the wires. The foam can then be glued to the sides of the rear panel, covering the crossover unit. I found spray adhesive, available in pressure pack cans, particularly useful for this purpose. The box should be lined on all sides and on the rear panel but not on the front baffle.

The wires to the mid-range and high-frequency drivers should now be passed through a small hole, previously drilled in the mid-range enclosure, which should then be sealed carefully with silicone sealant. This is particularly important since it is imperative that pressure from the main bass-driver enclosure is not applied to the rear of the mid-range driver. If this is allowed to occur the mid-range cone will be displaced from its equilibrium position by the bass pressure, resulting in degraded distortion performance.

The wires can now be soldered to the mid-range and high-frequency drivers, being careful to connect the drivers with the correct orientation. Each has one of its terminals marked by a dot or a positive sign (+). The wires soldered to the crossover should also be marked for polarity. The usual convention is to assign any distinguishing mark on the wires (e.g. a stripe) to be connected to the terminal marked in the drivers. If in doubt, study the wiring diagram of the crossover shown in this article and compare this to the actual crossover you have been supplied. It is particularly important to ensure that the drivers are connected right way round, otherwise severe frequency response errors will result.

The final stage in the construction is to screw the drivers into position. It is important, once again, to ensure that the drivers, when mounted, will form a good seal against the front panel. One of the best ways to accomplish this is to use foam tape, available from hardware stores. This material is adhesive on one side and is intended for use on windows and doors etc. The tape can be stuck to the front of the baffle so that it forms a gasket against which the driver chassis can mount. Once all three holes are lined with the foam tape, screw the drivers into position being careful not to overtighten the screws, particularly those for the mid-range and tweeter.

Before connecting the loudspeaker to an amplifier, first use a 1.5 V battery to check that the loudspeaker is working correctly. This is done by touching the two ends of the battery to a pair of wires connected to the loudspeaker. When the battery is connected a thump will be heard from the loud-



speaker. Check that all three drivers are contributing by listening to each in turn while touching one wire to the battery in turn. If the battery positive terminal is connected to the positive terminal of the loudspeaker, the woofer cone should move out. Similarly, if the battery connections are reversed the woofer cone should move in. Do not use a battery larger than 1.5 V or damage might result to the loudspeaker.

## Conclusion

The overall result is evident from the measured response (Figure 8). But, as with all loudspeakers, you should audition a pair for yourself, preferably in reasonable surroundings so that they give of their best. I think you'll be as pleased with their performance as I am, not to mention all those who heard the prototypes.

I would recommend an amplifier capable of 100-150 watts as a minimum, particularly if you have, or intend to have, a compact disc player. Even in the average-to-large domestic lounge room, this power level is just adequate to handle the dynamic range at 'normal' listening levels. Ideally, a system capable of 350-400 watts would allow full reign to the sort of music dynamics now available on CDs. This is not to say the speakers are insensitive, I'm just indicating the sort of performance modern recordings require.

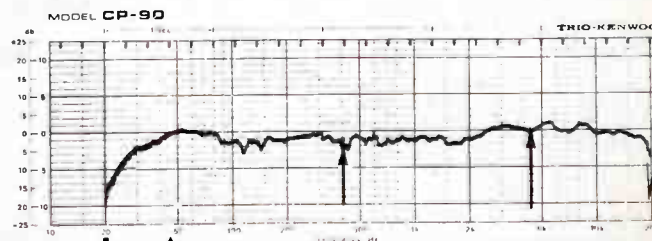


Figure 8. Overall frequency response of the AEM6103 three-way loudspeakers, measured in a room. The bass end response curve shown on the cover was measured outdoors (free-field response). The arrows show the crossover points.

# ELECTRONIC FACILITIES

TECHNOLOGY TO MAKE IT HAPPEN

## 74LS SERIES

## 4000 SERIES CMOS

## TRANSISTOR

PART NUMBER	PRICE EA	PART NUMBER	PRICE EA	PART NUMBER	PRICE EA
74LS00	.55	4001B	.50	BC547	
74LS02	.55	4002B	.50	NPN SILICON	.15
74LS04	.55	4006B	.85	BC548	
74LS05	.55	4007UB	.50	NPN SILICON	.15
74LS08	.55	4008B	.85	BC549	
74LS10	.55	4011B	.50	NPN SILICON	.15
74LS11	.55	4012B	.50	BC557	
74LS13	.55	4013B	.90	PNP SILICON	.15
74LS14	.65	4015B	1.20	BC558	
74LS20	.55	4016B	.80	PNP SILICON	.15
74LS22	.50	4017B	1.40	BC559	
74LS30	.60	4020B	1.40	PNP SILICON	.15
74LS32	.60	4023B	1.50	BC327	
74LS38	.65	4024B	1.10	PNP SILICON	.20
74LS42	.65	4025B	.90	BC337	
74LS74A	.55	4040B	1.60	PNP SILICON	.20
74LS83A	.75	4044B	.95	OVER 25 ITEMS OF ANY TYPE	
74LS86	.50	4049B	.50	LESS 7½%	
74LS90	.75	4069UB	.50	<b>MEMORY</b>	
74LS93	.80	4071B	.50	<b>PART NUMBER</b>	<b>PRICE EA</b>
74LS109	.75	4081B	.50	4164P-15A	
74LS123	.90	4085B	.50	150ns 64K	
74LS125A	.65	4093B	.50	DYNAMIC RAM	1.80
74LS126	.75	40160B	1.65	6264LP-15	
74LS132	.90	40174B	.90	150ns 8K X 8	
74LS136	.75	4503B	.65	STATIC CMOS RAM	6.30
74LS138	.90	4510B	1.60	2764-25	
74LS139	.85	4512B	1.60	250ns 8K X 8 EPROM	4.90
74LS157	.65			6116LP-3	
74LS161A	.75			150ns 2K X 8	
74LS162A	.80			STATIC CMOS RAM	3.50
74LS164	.85			2716-45	
74LS165	.90			450ns 2K X 8	
74LS174	.75			EPROM	5.95
74LS175	.75			2732A	
74LS190	.95			250ns 4K X 8	
74LS192	.80			EPROM	5.60
74LS240	1.45				
74LS244	1.45				
74LS245	1.45				
74LS247	.95				
74LS251	.85				
74LS257A	.90				
74LS258A	.90				
74LS259	.90				
74LS365A	.90				
74LS367A	.75				
74LS368A	.80				
74LS373	1.45				
74LS374	1.45				
74LS377	1.45				
74LS390	1.40				
74LS393	.95				
OVER 25 ITEMS OF ANY TYPE LESS 7½%		OVER 25 ITEMS OF ANY TYPE LESS 7½%		OVER 25 ITEMS OF ANY TYPE LESS 7½%	

# ELECTRONIC FACILITIES

## SPECIAL DEVICES

MN 6631A 5 Channel CMOS electronic switch	\$5.94
MN 6632A 2-Channel CMOS electronic volume control	\$8.64
MN 1280S CMOS LSI for power supply voltage detector	\$2.28
MN 6514 Switched capacitor low-pass filter CMOS LSI	\$4.68
MN 6515 Switched capacitor band-pass filter CMOS LSI	\$4.68
MN 6516 Switched capacitor high-pass and low-pass filter CMOS	\$5.94
OH-001-Q GaAs Hall effect element	\$3.90

## ELECTROLYTIC CAPACITORS

[ALL ELECTROLYTIC CAPACITORS ARE RB' TYPE SINGLE ENDED]

1/50	.15
4.7/35	.15
10/35	.20
22/35	.20
33/25	.20
47/35	.25
100/25	.25

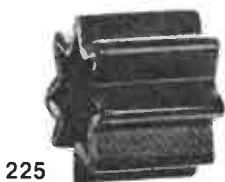
OVER 25 ITEMS OF ANY TYPE LESS 7½%

## RESISTORS

E 12 1/4 w carbon film resistors \$3.00 per 100. Min of 50.

## TOP QUALITY LOW COST HEATSINKS

225	.95
The 225 SERIES heat sink is a press-on, low cost unit for TO-5 devices.	
270	.55
his series is designed for use with plastic-cased TO-220 style devices.	
637	\$1.50
The 637 SERIES are high performance heat sinks designed for plastic power transistors.	
673	.95
The 673 SERIES heat sink is designed for use with either the TO-3, TO-66, or two TO-220 style devices where low height is required.	



225



270



637



673

OVER 25 ITEMS OF ANY TYPE LESS 7½%

ALSO AVAILABLE FROM



**ELECTRONIC FACILITIES PTY. LIMITED**

67 Dickson Avenue, Artarmon.  
Sydney N.S.W. 2064 Australia.  
Telex AA177084

**BRYAN CATT INDUSTRIES PTY. LTD.**

10/59-61 Gympsea Bay Road, Gympsea.  
N.S.W. Australia 2227  
PO BOX 146, Cronulla.  
N.S.W. Australia 2230  
TEL (02) 526 2222 526 2900  
Telex: AA 70492

**Mail Orders:** PO Box 351, Artarmon, N.S.W. 2064 TOLL FREE (008) 22 6385 Sydney 439 3786



**DEALER AND TRADE ENQUIRIES WELCOME.**



# aem data sheet

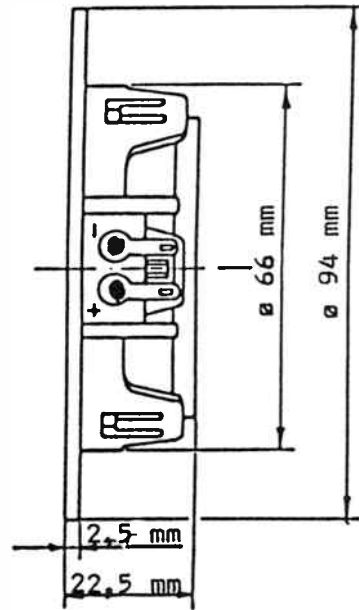
## D19TD-05

### 3/4" (19 mm) Vifa dome tweeter with magnetic fluid

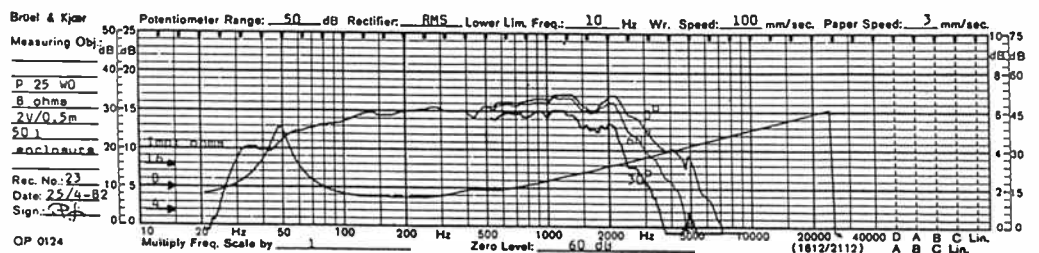
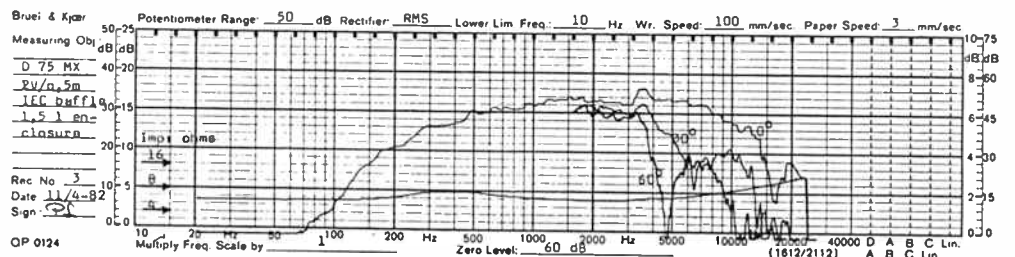
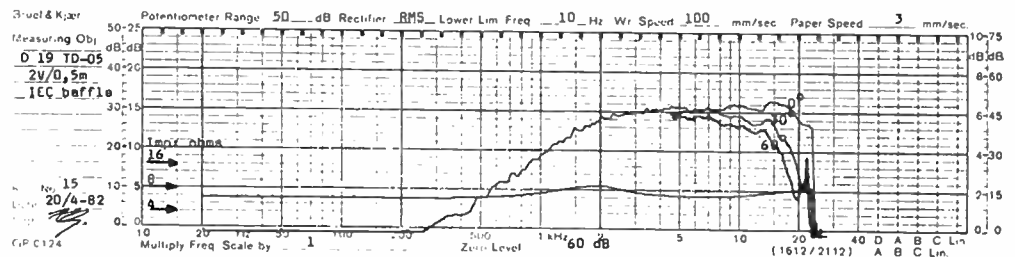
The D19TD-05 is a magnetic fluid version of the Vifa D19TD soft dome tweeter. The diaphragm is formed from a special plastic with high internal damping which ensures a very smooth frequency response. The high frequency dispersion is excellent. This tweeter is also recommend for 2-way systems due to the excellent damping and cooling of the voice coil from the magnetic fluid.

#### Technical Data

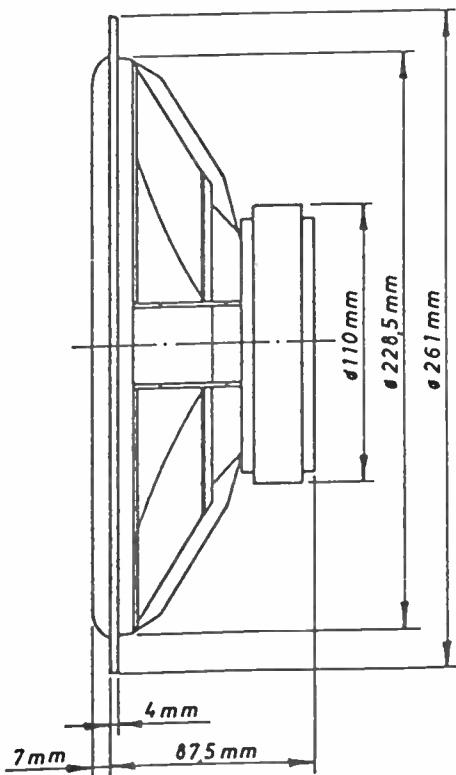
Nominal impedance	8 ohms
Frequency range	2.5-20 kHz (DIN 45500)
Free air resonance	1700 Hz
Char. sensitivity	89 dB (1 W, 1 m)
Nominal power	80 W (DIN 45573)
	(fo: 5000 Hz, 12 dB/oct)
Force factor (Bl product)	2.6 Tm
Voice coil diameter	19 mm
Voice coil height	1.5 mm
Air gap height	2 mm
Voice coil resistance	6.2 ohms
Effective cone area	4 cm <sup>2</sup>
Moving mass (incl. air)	0.2 g
Weight	0.28 kg



Vifa drivers are distributed in Australia by Scan Audio, PO Box 242, Hawthorn 3182 Vic. (03) 819 5352.







# P25WO

## 10" (254 mm) Vifa polycone woofer

The P25WO is a sturdy 10" (254 mm) diameter woofer with a special Vifa 'polycone'. This cone material has high internal damping and increased stiffness in proportion to normal cone plastics, such as bextrene and polypropylene.

A high force factor and a progressive suspension means that this woofer is well suited for bass reflex enclosures.

### Technical Data

Nominal impedance	8 ohms
Frequency range	25-3000 Hz (DIN 45500)
Free air resonance	25 Hz
Operating power	5.0 W (DIN 45500)
Characteristic sensitivity	.89 dB (1 W, 1 m)
Nominal power	60 W (DIN 45573)
Music power	100 W (DIN 45500)
Force factor (BI product)	9.4 Tm
Voice coil diameter	40 mm
Voice coil height	14 mm
Air gap height	6 mm
Voice coil resistance	5.7 ohms
Effective cone area	350 cm <sup>2</sup>
Moving mass (incl. air)	44 g
<b>Thiele/Small Parameters</b>	

Qm: 3.15

Qe: 0.46

Qt: 0.40

Vas: 180 l

Weight ..... 1.95 kg

# D75MX

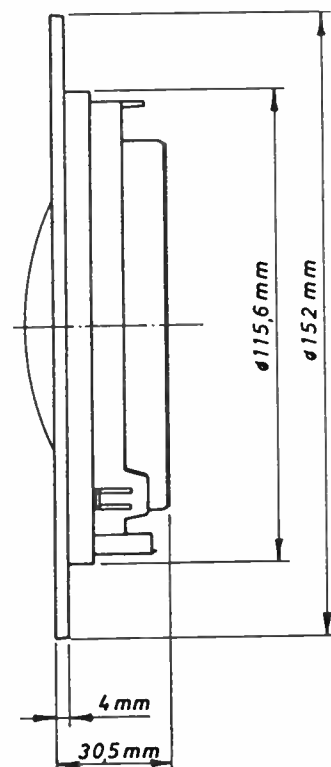
## 3" (75 mm) Vifa dome midrange

The D75MX is a very high quality 3" (75 mm) soft dome midrange drive unit. The diaphragm is formed from a special plastic with high internal damping which ensures a very smooth frequency response.

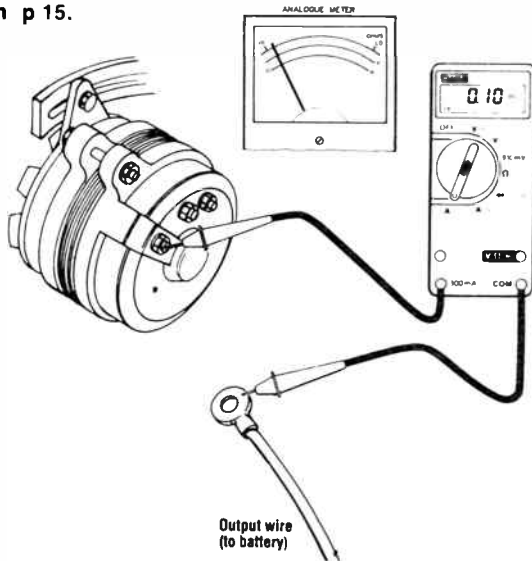
The driving system is very efficient due to an internal ferrite magnet. This allows a special venting leading to a very linear impedance characteristic.

### Technical Data

Nominal impedance	8 ohms
Frequency range	350-5000 Hz (DIN 45500)
Free air resonance	300 Hz
Characteristic sensitivity	.91 dB (1 W, 1 m)
Nominal power	.80 W (DIN 45573)
	(fo: 500 Hz, 12 dB/oct)
Force factor (BI product)	4.7 Tm
Voice coil diameter	75 mm
Voice coil height	3 mm
Air gap height	2 mm
Voice coil resistance	7.2 ohms
Effective cone area	.55 cm <sup>2</sup>
Moving mass (incl. air)	3.6 g
Weight	0.65 kg



► from p 15.



**Figure 11.** To check alternator diode leakage, connect the meter in series with the alternator output terminal (engine not running) and set the meter to read current. Use the 10 amp range unless you're sure the current is under 1 A. leakage should be no more than a few milliamps at most, often less than half milliamp.

Check the leakage current of the alternator diodes as shown in Figure 11. Once you have determined how much current the diodes draw, leave the alternator disconnected to avoid confusing its draw with that of another component. Remember that under-bonnet lights, trunk lights, dome lights (courtesy lights) and computers all draw current and are apt to be on while working on the car. A piece of tape over the door switch will keep the dome lights off.

Short circuits are usually caused by a defective component or insulation that has rubbed through. Note — the old practice of using the meter in series and setting it to volts no longer works very well. With new computer systems and other digital circuits there are some devices that are always "on"; the meter will show battery voltage when all is normal. It is difficult to sort out what is a normal current draw and what is not using the voltage method. So, for computer equipped cars use the method for locating current drains.

If you're working on a non-computer car, use the same process you use to find current drains in finding shorts, except set the DMM to the volts dc function, and hook it up in series with the battery. Doing so will limit the amount of current that can flow, saving many blown fuses, lots of time, and skinned fingers from changing fuses. Remember the alternator diodes leak some current, so disconnect it to avoid confusion.

As long as there is a current draw, for whatever reason, the meter will read battery voltage. As soon as the current draw is eliminated the meter will read zero.

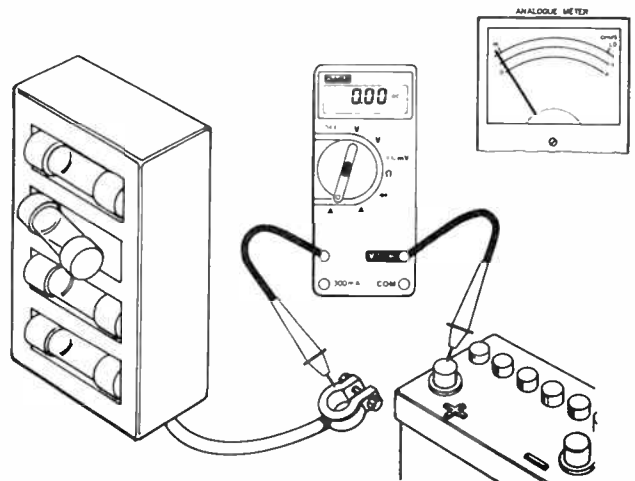
High resistance grounds can be the most frustrating electrical problems you will face. They can produce a variety of bizarre symptoms that doesn't seem to have anything to do with the cause, when you finally find it. The symptoms include lights that glow dimly, lights that come on when others should, gauges that change when the headlights are turned on, and lights that don't come on at all.

With the new computer systems, high resistance in ground wires and sensor leads can produce all sorts of unpredictable symptoms. Apply conductive grease, available at electron-



ics suppliers and some automotive parts stores, to connections before you re-assemble them. This will reduce corrosion.

Pay particular attention to ground terminals in the vicinity of the battery where acid speeds corrosion. Often a wire that is broken through except for a few strands will produce the same symptom as a corroded ground connection. ⚡



**Figure 12.** Isolating the circuit causing a current drain. In this sort of test, do not run or crank the engine and do not operate accessories, lights etc, that may draw more than 10 amps — you may irreparably damage your meter.

Set the meter to read current (a high range initially) and connect it in series with the battery. You can isolate the circuit causing the current drain by pulling one fuse at a time while watching the meter reading. When the reading drops, you've isolated the circuit.

Put the fuse back and disconnect the individual components in that circuit one at a time to find the offender. Keep in mind that there may be computer circuits etc, that draw current normally all the time and such devices may not all be on the same fuse.

We would like to acknowledge the kind assistance of Elmeasco Pty Ltd for providing information and material used for the compilation of this feature.

# HARD TO GET ITEMS are now EASY TO GET

- Components
- Tools
- Kits
- Books

For  
Hobbyist & Professionals

Ian J. Truscotts

## ELECTRONIC WORLD

30 Lacey St, Croydon. Vic.  
(03) 723 3860 — 723 3094

• MAIL ORDER WANT LISTS WELCOMED

## ADMARKET

Readers' free adverts

### READERS-CLUBS-ASSOCIATIONS

WE'LL PUBLISH your advertisement of up to 32 words (maximum), totally free of charge.

Write or type out your copy on a clean sheet of paper. But please make it legible, otherwise it may not turn out as you intended! Copy must be with us six weeks prior to the month of issue. Every effort will be made to publish your advertisement but no responsibility for so doing is accepted or implied.

### CONDITIONS

You must include your name and 'phone number and/or address within the 32 words (for amateurs, 'QTHR' is acceptable). Accepted abbreviations such as DSDD, 100 W RMS, ONO etc, may be used. Please include your name and full address plus 'phone number with a covering letter. Private advertisements only will be accepted. We have 'small ads' for traders, who should contact our advertising representatives.

**SELL: VZ300 COLOUR COMPUTER**, used once. All original accessories and pakaging. \$80 ONO. **BEETHOVEN MICROBEE SOUND SYNTHESISER** in good condition, with software. \$80 ONO. Phone Douglas (02) 560 8348, afternoons.

**SELL: MICROPROCESSOR BASED AUDIO SPECTRUM ANALYSER: IU1E, IE30A and IE17A.** Portable NiCad operation, pink noise generator, printer and CRO interface, mic leads, briefcase supplied. \$4200. Call Phillip (02) 698 7603.

## FLUKE 20 SERIES ANALOG/DIGITAL MULTIMETERS FOR THE TOUGHEST ENVIRONMENTS



### FLUKE 21 & 23

Yellow case colour  
Analog/Digital display  
Touch Hold™ function (23)  
0°C to 50°C operation  
0.5% & 0.3% basic accuracy  
100  $\mu$ V to 1000V dc  
1mV to 750V ac  
10  $\mu$ A to 10A (23), all fused  
10  $\mu$ A to 320 mA (21), fused  
Three-year warranty

### FLUKE 25 & 27

Charcoal or yellow case colour  
Analog/Digital display  
Touch Hold™ function  
-15°C to 55°C operation  
0.1% basic accuracy  
100  $\mu$ V to 1000V ac and dc  
0.1  $\mu$ A to 10A, all fused  
Relative (difference) mode (27)  
MIN/MAX recording mode (27)  
Ruggedized, waterproof case  
Two-year warranty

FROM THE WORLD LEADER  
IN DIGITAL MULTIMETERS.



See the Fluke 20 series at leading electronics stores or contact us for data

**ELMEASCO**  
Instruments Pty. Ltd.

<b>NEW SOUTH WALES</b> 15 McDonald Street MORTLAKE P.O. Box 30, CONCORD NSW 2137 Tel (02) 736 2888 Telex AA25887	<b>VICTORIA</b> 12 Maroonah Highway, RINGWOOD P.O. Box 623 RINGWOOD VIC 3134 Tel (03) 879 2322 Telex AA30418 ELTENT	<b>QUEENSLAND</b> Tel (07) 369 8688 <b>S AUSTRALIA</b> Tel (08) 344 9000 <b>W AUSTRALIA</b> Tel (09) 481 1500
--	---	--

## FOR QUALITY AND VALUE TALK TO THESE PEOPLE ABOUT FLUKE MULTIMETERS

### A.C.T.

Actiec Pty Ltd  
34 Geelong St Fyshwick  
(062) 80 6576

### N.S.W.

Ames Agency Pty Ltd  
605 Elizabeth St Redfern  
699 4524

George Brown & Co Pty Ltd  
174 Parramatta Rd  
Camperdown - 519 5855  
Newcastle - 69 6399  
Canberra - 80 4355

Bryan Catt Industries Pty Ltd  
10/59-61 Gympie Bay Rd  
Gympie  
526 2222

Collier Tools (Aust) Pty Ltd  
185 Parramatta Rd  
Homebush  
763 1888

D G E Systems Pty Ltd  
103 Broadmeadow Rd  
Broadmeadow  
(049) 69 1625

Davred Electronics Pty Ltd  
127 York St Sydney  
267 1385

W F Dixon & Co Pty Ltd  
P O Box 42 Wickham  
(049) 61 5628

Macelec Pty Ltd  
99 Kenny St Wollongong  
(042) 29 1455

Paul's (Merchants) Pty Ltd  
22 Canterbury Rg  
Bankstown  
709 2311

Radio Despatch Service  
869 George St Sydney  
211 0291

Selectro Parts Pty Ltd  
482 Hume Hwy Yagoona  
708 3244

Standard Communications  
Pty Ltd  
6 Frank St Gladesville  
896 1755

Geoff Wood Electronics  
Pty Ltd  
656A Darling St Rozelle  
810 6845

### WESTERN AUSTRALIA

Atkins Carlyle Ltd  
1 Milligan St Perth  
321 0101

Dobbie Instruments (Aust)  
Pty Ltd  
9 Boag Rd Morley  
276 8888

Cairns Instrument Services  
32 Wickham St East Perth  
325 3144

Willis Trading Co Pty Ltd  
165 Albany Hwy  
Victoria Park  
470 1118

### VICTORIA

Radio Parts Pty Ltd  
562 Spencer St  
West Melbourne  
329 7888

G B Telespares Pty Ltd  
504 Queensbury Rd  
North Melbourne  
328 3371

Browntronic Pty Ltd  
93 Sackville St Collingwood  
419 3986

R K B Agency  
20 Council St Hawthorn  
82 7704

A J Ferguson & Co Pty Ltd  
558-568 Swanston St Carlton  
347 6688

SIRS Sales Pty Ltd  
4 Edols Pl North Geelong  
(052) 78 1251

### TASMANIA

George Harvey Electrics  
Head Office  
76 York St Launceston  
(003) 31 6533  
Hobart - (002) 34 2233

### SOUTH AUSTRALIA

Protronic Pty Ltd  
174 Wright St Adelaide  
212 3111

Trio Electrix Pty Ltd  
177 Gilbert St Adelaide  
212 6235

Redarc Electronics  
253 Main Rd Blackwood  
278 7488

### QUEENSLAND

L E Boughen & Co  
33 Railway Tce Milton  
369 1277

Colourview Wholesale  
5 Commerce St Salisbury

Fred Hoe & Sons Pty Ltd  
246 Evans Rd Salisbury Nth  
277 4311

Nortek  
36 Punari St Townsville  
(077) 79 8600

St Lucia Electronics  
71-77 Brunswick St  
Fortitude Valley  
52 7466

Selectro Parts (Qld)  
44 Esher St Ekibin  
394 2422

### NORTHERN TERRITORY

Thew & McCann (NT) Pty Ltd  
Menmuir St Welliellie Darwin  
(089) 84 4999



**ELMEASCO**  
Instruments Pty. Ltd.

<b>NEW SOUTH WALES</b> 15 McDonald Street MORTLAKE P.O. Box 30, CONCORD NSW 2137 Tel (02) 736 2888 Telex AA25887	<b>VICTORIA</b> 12 Maroonah Highway RINGWOOD P.O. Box 623 RINGWOOD VIC 3134 Tel (03) 879 2322 Telex AA30418 ELTENT	<b>QUEENSLAND</b> Tel (07) 369 8688 <b>S AUSTRALIA</b> Tel (08) 344 9000 <b>W AUSTRALIA</b> Tel (09) 481 1500
--	--	--

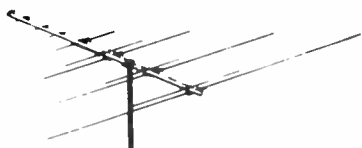
# LOST CHANNEL 0? THEY'VE MOVED TO UHF!



## Economy UHF/VHF

It's made for those good reception areas! If you're close to the transmitter you won't suffer on quality but you will save money. Channels 0 to 11 VHF, FM and UHF Band 4 including Channel 28! Cat L-4027

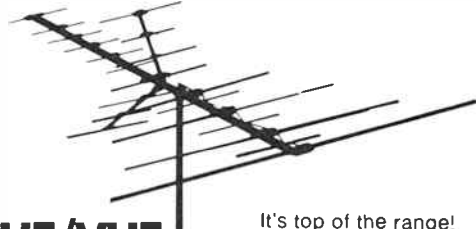
JUST **\$39<sup>95</sup>**



## Combined UHF/VHF Antenna

Why use two antennas when one will handle the job? Our combined UHF/VHF antenna is one of our most popular models. It's ideal for metropolitan reception areas! Great value for a dual purpose antenna! Cat L-4020

VALUE **\$59<sup>95</sup>**



## UHF/VHF Antenna With Reflector

It's top of the range! Particularly suited to fringe (or poor reception) areas you'll get a clear sharp picture with this one. Both VHF and UHF Band 4 & 5 with inbuilt reflector for maximum gain/minimum ghosting! Cat L-4018

ONLY **\$79<sup>95</sup>**

## STORE LOCATIONS

### NSW

Swift & Young Sts. T55 Terrace Level Shop 1, 65-75 Main St 613 Princess Hwy Oxford & Adelaide Sts 531 Pittwater Rd Campbelltown Mall Queen St Shop 235, Archer St Entrance 147 Hume Hwy 164 Pacific Hwy 315 Mann St 4 Florence St Elizabeth Dr & Bathurst St 450 High St 173 Maitland Rd, Tighes Hill Lane Cove & Waterloo Rds George & Smith Sts The Gateway High & Henry Sts 818 George St 125 York St	<b>Albury</b> Bankstown Sq Blacktown Blakehurst Bondi Junction Brookvale Campbelltown Chatswood Chase Chullora Gore Hill Gosford Hornsby Liverpool Maitland Newcastle North Ryde Parramatta Penrith Railway Square Sydney	21 8399 707 4888 671 7722 546 7744 387 1444 93 0441 27 2199 411 1955 642 8922 439 5311 25 0235 477 6633 600 9888 33 7866 61 1896 88 3855 689 2188 32 3400 211 3777 267 9111	Treloar's Bldg, Brisbane St 263 Keira St ACT 96 Gladstone St VIC Creswick Rd & Webster St 145 McCrae St Shop 46, Box Hill Central, Main St Hawthorn Rd & Nepean Hwy 260 Sydney Rd 1150 Mt Alexander Rd Nepean Hwy & Ross Smith Ave Shop 9 110, High St 291-293 Elizabeth St Bridge Rd & The Boulevarde Springvale & Dandenong Rds QLD 157-159 Elizabeth St 166 Logan Rd Gympie & Hamilton Rds	Tamworth Wollongong Fyshwick Ballarat Bendigo Box Hill East Brighton Coburg Essendon Frankston Geelong Melbourne Richmond Springvale Brisbane Buranda Chermside	66 1961 28 3800 80 4944 31 5433 43 0388 890 0699 592 2366 383 4455 379 7444 783 9144 43 8522 67 9834 428 1614 547 0522 229 9377 391 6233 359 6255	Queen Elizabeth Dr & Bernard St Gold Coast Hwy & Welch St Bowen & Ruthven Sts Ingham Rd & Cowley St West End Cnr Pacific Hwy & Kingston Rd SA Wright & Market Sts Main South & Flagstaff Rds Main North Rd & Darlington St 24 Park Terrace WA Wharf St & Albany Hwy 66 Adelaide St William St & Robinson Ave Centreway Acde, Hay St TAS 25 Barrack St NT 17 Stuart Hwy	Rockhampton Southport Toowoomba Townsville Underwood Adelaide Darlington Enfield Salisbury Cannington Fremantle North Perth Perth City Hobart Stuart Park	27 9644 32 9863 38 4300 72 5722 341 0844 212 1962 298 8977 260 6088 281 1593 451 8666 335 9733 328 6944 321 4357 31 0800 81 1977
---	--	--	--	---	---	--	---	--

### Dear Customers,

Quite often, the products we advertise are so popular they run out within a few days, or unforeseen circumstances might hold up shipments so that advertised lines are not in the stores by the time the advert appears. And very occasionally, an error might slip through our checks and appear in the advert (after all, we're human too!) Please don't blame the store manager or staff: they cannot solve a dock strike on the other side of the world, nor fix an error that's appeared in print. If you're about to drive across town to pick up an advertised line, why not play it safe and give them a call first - just in case! Thanks Dick Smith Electronics

### MAJOR RESELLERS

NSW: • Ballina: A Cummings & Co 91-93 River St 86 2284 • Bathurst: Electronic Shop 74 Bentick Street, 31 4421 • Bowral: Barry Gash Electronics 370 Bong Bong St 61 2577 • Broken Hill: Hobbies & Electronics, 37 Oxide St 88 4098 • Charlestown: Newtronic 131 Pacific Hwy 43 9600 • Coffs Harbour: Coffs Harbour Electronics 3 Coffs Plaza Park Ave 52 5684 • Deniliquin: Den Electronics, 220 Cressy St, 81 3672 • East Maitland: • Gosford: Tomorrows Electronics & HiFi, 68 William St, 24 7246 • Lismore: Decro 3A-6, 18 Carrington St, 21 4137 • Port Macquarie: Hall of Electronics, Horton Centre, Horton St, 83 7440 • Orange: Fyle Electronics 173 Summer St, 62 6491 • Tumut: Tumut Electronics Wynyard St, 471 631 • Tweed Heads: Stuarts Electronic Sales Sh 3, 4 Stuart St, • Swansea: Swansea Electronics, 184 High St, 711 674 • Wagga: Philips Electronics 82 Forsyth St, 21 6558 • Windsor: M & E Electronics Sh 7, McEwans Arcade 206 George St, 77 5935 • Young: Keith Donges Electronics 186 Boorowa 821 279 VIC: • Hamilton: John Thompson & Co 138-148 Gray St, 72 2000 • Echuca: Webster Electronics 220 Packenham St 82 2956 • Mildura: McWilliams Electronics 110A Langtree Ave, 23 6410 • Morwell: Morewell Electronics, 95 George St, 34 6133 • Shepparton: GV Electronics Centre 100 High St, 21 8866 QLD: • Atherton: Maatens Music Centre 55 Main St, 91 1208 • Bundaberg: PM Electronics, Takalvan St, 72 8272 • Cairns: Electronic World Shop 27 K-mart Westcourt Plaza 518 555 • Gladstone: Purely Electronics Shop Cnr Hebert & Auckland Sts 72 4321 • Mackay: Stevens Electronics, 42 Victoria St, 51 1723 • Maryborough: Keller Electronics, 218 Adelaide St, 21 4559 • Mt Isa: Outback Electronics 71 Barkly Hwy 433 331 • Rockhampton: Purely Electronics, 15 East St, 21 058 SA: • Mt Gambier: Hutchessons Communications, 5 Elizabeth St, 25 6404 • Whyalla: Eyre Electronics Shop 2 Forsythe St, 45 4764 WA: • Albany: Micro Electronics 133 Lockyer Ave 41 3432 TAS: • Launceston: Advanced Electronics 5A The Quadrant 34 1399 NT: • Darwin: Ventronics 24-26 Kavanagh St, 81 3491

## DSX PRESS ORDER SERVICE

Use your Bankcard, Mastercard or Visacard.  
Just phone **008 2266 10** (toll free) for  
fast 24 hour despatch of your order.  
Enquiries: By mail, or phone (02) 8882105

POST & PACKING CHARGES	Order Value	Charge	Order Value	Charge
	\$5 00 - \$9 99	\$2 00	\$50.00 - \$75.00	\$6 00
	\$10 00 - \$24 99	\$3 50	\$75.00 or more	N.A.
	\$25 00 - \$49 99	\$4 50		

Terms available to approved applicants

SA Customers: Credit facilities available through

AGC Adelaide: 10 Pulteney St, Adelaide



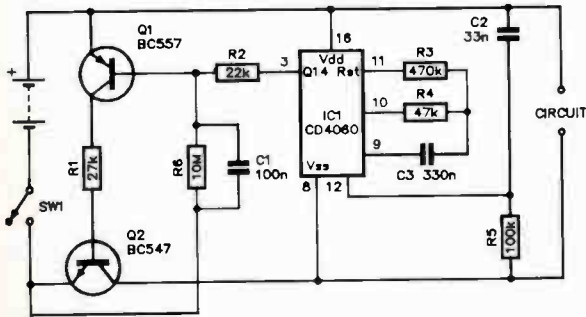
ORDERS OVER \$75  
FREE DELIVERY

# DICK SMITH ELECTRONICS

PTY LTD

P.O. Box 321, North Ryde N.S.W. 2113. Tel: 888 3200

# BenchBook



## Auto-shutdown for battery gear

Here's a simple circuit to provide automatic 'power-down' for battery-operated equipment so that the battery does not go flat on you because the equipment was not turned off when last used.

It's connected between the usual supply on/off switch and the circuitry in the equipment. It takes about nine minutes to shutdown. Once it has shut down, all you need to do is turn the supply switch off, then on again.

A 4060 CMOS 14-stage oscillator-counter is at the heart of the circuit. This determines the equipment on time. The oscillator frequency is set by the values of R3-R4/C3. The values shown provide a frequency around 30 Hz. This is down-counted by 16,384. When the count finishes, the 14th stage output (pin 3) goes high, turning Q1 off which turns Q2 off. Only leakage current, via R6 (10M) flows then. It's about a microamp, or so.

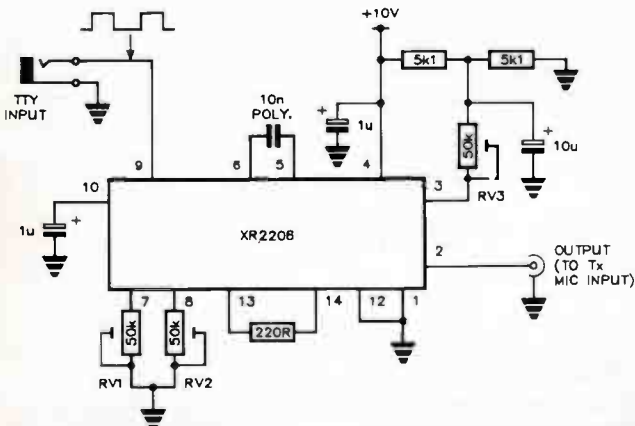
This circuit is intended for equipment drawing only modest current. However, equipment drawing high currents could be accommodated by using a power Darlington for Q2.

— G. Moss  
Newtown, NSW

## Low cost RTTY modulator

For those amateurs playing with the AEM3500 Listening Post as a RTTY demodulator and looking for a companion modulator to get on the air with RTTY, then this circuit offers great potential.

This RTTY modulator was originally written up in the excellent "RTTY Loop" column in 73 Magazine for August 1985, which is conducted by Marc Leavey WA3AJR. It em-



plains the XR2206 function generator IC as an audio frequency-shift keyed (AFSK) oscillator to produce two tones when 'keyed' by a digital signal.

The oscillator's output is relatively low distortion sine wave from pin 2. The output is coupled directly to the transceiver's mic input. Most transceivers around have an ac-coupled RC input network, so no RC output coupling is really required. However, it would be wise to check first, before hooking up the modulator.

The keying voltage is fed to pin 9 (referenced to ground), and Leavey recommends this should swing from less than one volt to more than two volts.

The two tones produced are dependent on the capacitor between pins 5 and 6, and the resistance to ground from pin 7 and pin 8, RV1 and RV2, respectively. Thus, the latter who are 50k trimpots and, ideally, should be 10-turn cermet types. The capacitor between pins 5 and 6 should be a polyester or polycarbonate type for best stability and circuit repeatability.

When a 'high' is present on pin 9, the output frequency is determined by RV1. When a 'low' is on pin 9, it's determined by RV2. You can determine the output frequency from:

$$f = 1/(R_x \times C)$$

Where  $R_x$  = either RV1 or RV2,

and  $C$  = the capacitance between pins 5 and 6.

With a 10n capacitor and RV1 and RV2 around 45k, the output would be around 2200 Hz.

If you wish, you could drop RV1 and RV2 to 25k each and use a 27k resistor in series with each to give more restricted range of adjustment.

The actual 'mark' and 'space' frequencies will depend on whether your gear is 'mark high' or 'mark low'. Set it up to suit yourself.

The actual output frequencies are immaterial, so long as the shift (difference between them) is correct, except for FM VHF/UHF operation where they must comply with the 'standard' 2125/2295 (170 Hz shift) or 2125/2975 (850 Hz shift). Generally, 850 Hz shift is used on FM on the VHF/UHF bands. On HF SSB, it doesn't matter, so long as the shift is correct and you're within the transmitter's filter passband.

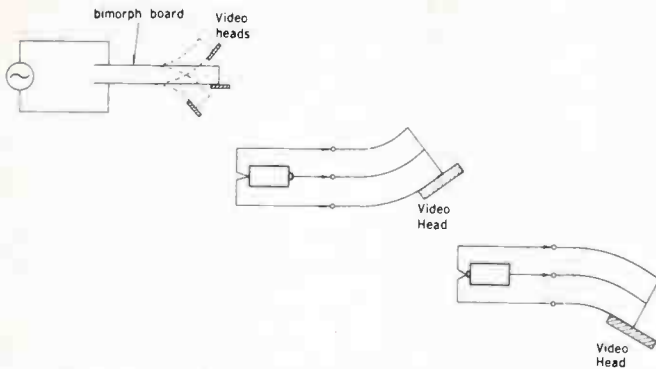
Output amplitude is controlled by RV3. According to the specs from Exar, you get about 60 mV of output per k-ohm of resistance here. The two 5k1 resistors simply give a 'half rail' supply point (two 4k7s would do). You should be able to get around 3 V peak-to-peak output with RV3 at maximum resistance. 🐘

Roger Harrison VK2ZTB

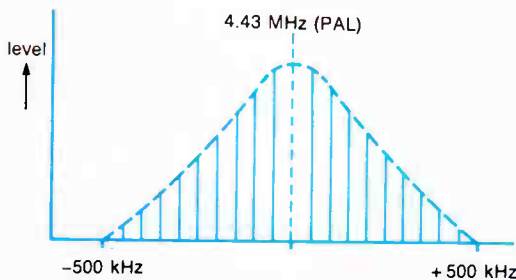
**Benchbook** is a column for circuit designs and ideas, workshop hints and tips from technical sources of the staff or you — the reader. If you've found a certain circuit useful or devised an interesting circuit, most likely other readers would be interested in knowing about it. If you've got a new technique for cutting elliptical holes in zippy boxes or a different use for used solder, undoubtedly there's someone — or some hundreds — out there who could benefit from your knowledge.

We'll pay from \$10 to \$100 for each item published. Send your gems to 'Benchbook', Australian Electronics Monthly, PO Box 289, Wahroonga NSW 2076. Please include your postal address for publication with your item(s).

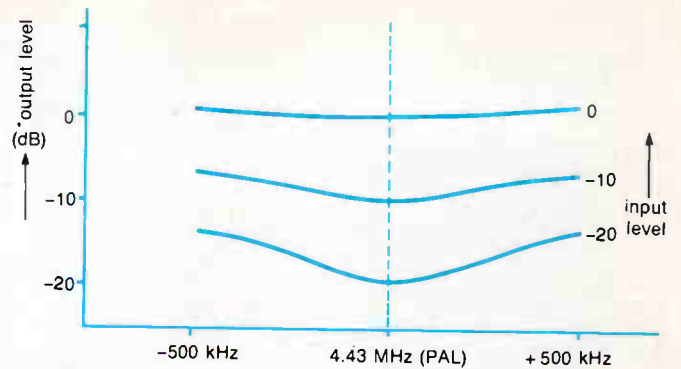
As far as reasonably possible, material published in Benchbook has been checked for accuracy and feasibility etc, but has not necessarily been built and tested in our laboratory. We cannot provide constructional details or conduct correspondence or technical enquiries.



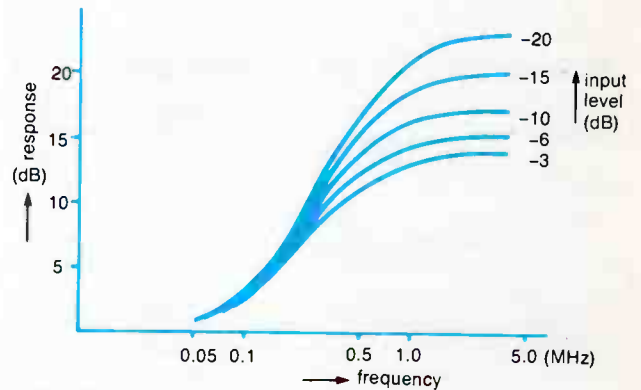
**Figure 17. Dynamic track following is achieved by having the heads mounted on a 'bimorph' ceramic plate. This comprises two tiny slabs of ceramic that bend slightly when a voltage is applied, varying the head azimuth as required.**



**Figure 18. The chroma (colour) signal spectrum is centred on 4.43 MHz for PAL video, with significant components (sidebands) distributed on either side for +/- 500 kHz.**



**Figure 19. 'Emphasis' is applied to the chroma bandwidth extremes at lower levels to preserve fine detail in the image.**



**Figure 20. To avoid noise causing colour shifts, pre-emphasis is applied to the video at the high frequency end of the video bandwidth, the amount of emphasis depending on the input level.**

pled to the ATF logic, the azimuth can be corrected for almost any type of playback azimuth. You may hear more about this.

### Comb filter

In a home VCR, chroma (colour) information is recorded at a lower frequency (737 kHz on Beta) than the luminance signal. This ensures the S/N ratio is preserved, but the possibility of crosstalk from adjacent tracks is a real problem.

It can be overcome by phase shifting every second field by 90 degrees per line on record, and restoring on playback. Any crosstalk is cancelled by a line delay that adds any adjacent channel information with that received two lines earlier, and 180 degrees phase-shifted; thus cancelling incoming crosstalk. A sort-of 100% feedback, called comb filtering and part of the Sony CCD-V8 design.

### Video "Dolby?"

Like subtle audio tones, the upper sidebands which provide fine colour detail tend to be lost in VCR record/playback. A professional type solution is included in the CCD-V8. Like the Dolby system, dependent on level, the upper sidebands are boosted and reduced again on replay. The scheme is illustrated in Figures 18 and 19.

### Burst emphasis

Colour shifts can be caused in VCR by noise obliterating colour bursts. As the Sony CCD-V8 works at the upper limits of technology it is understandable that the format calls for comb filtering, chroma emphasis, and also, the doubling of the burst record level with a halving on replay. This is how the previously impossible is achieved with enough latitude to ensure the hope of reasonable performance in an old and worn V8 camcorder. Figure 20 shows the pre-emphasis applied over the video bandwidth.

## Compatibility

This is the consumer's greatest concern. In the V8 format, can I a borrower and lender, be? Disregarding the audio and digital options in V8, Sony tell me that they are including in the PAL version all these enhancements, except the bipolar DTF which will not affect compatibility when it is introduced. What it must mean is a lack of cheap V8 format camcorders with minimal quality and without these sophisticated correction systems only possible through the use of LSI available to a "club" of big name manufacturers.

Although this may smell of a cartel, the assurance of a minimum standard by Philips and Dolby in the compact audio cassette has protected the consumer from buying useless rubbish that looks good, but may be cheap and misrepresented as the real thing.

If you buy any make of camcorder, VCR or a VC bearing the "V8" official stamp, they should be fully compatible if the 127 sponsors of the new format are on the ball.

However, a warning. The V8 format video on sale in NTSC areas is useless in PAL territory. Kodak tell me that it will be at least a year before their V8 video; first on the market over a year ago in the U.S., will be available in Australia in PAL. They talk about the V8 format on NTSC just reaching "Phase 2 with Phase 3 not far off."

## Looking at the CCD-V8E

Having dealt with all the ways and means, what do they add up to in the finished product? Sony's CCD-V8 camcorder and accessories are probably the most sophisticated equipment that modern science and technology has produced for use by ordinary people of reasonable means and intelligence. It is a one-hand imaging device. The right hand goes through the prosthetic grip. Weight has been reduced to 2.3 kg in-

cluding battery and VC. The (Betamovie camcorder, which does not replay, is 3 kg +). It is a small, well-balanced unit, easily carried for long periods. Bulk is 7768 cubic cm (Betamovie is 9817 cubic cm), and it weighs just 2.3 kg. Either hanging on the hand or balanced on the shoulder, it is no great burden to take it with you.

The CCD-V8 does not have auto focus and was left off, I understand, because it would add a lot of weight, bulk and cost. The removable EVF allows a clear image, so focus is instant by eye. White balance is automatic, merely a matter of pointing at a white subject and pushing a button. The lens cover has a white filter that will allow WB. Just as the Walkman and compact CD player have compact style, so does the whole CCD V8E.

In the hands, it has a comfortable feel about it. I like the large clear illuminated LCD panel at the back that tells you everything that is happening. The unit is built around a sturdy diecast chassis, and the head drum is machined to tolerances allowing headchanges without settings.

Sony designed and made their own LSI chips to achieve the miniaturization. Fast winding is good at 11 to 15 times play speed, in both directions; cue nine times, and review seven times. The lens system is good with a power zoom lens of 6xf = 12-72 mm, f1.4 tele 1.8, plus macro and filter. Diameter is 46 mm.

Light sensitivity is quoted as 22 Lux (2 ft-candles), which may be conservative as it is much less sensitive than other makes of video using picture tubes at 7-10 lux minimum, or the latest National CCD WVP F-2 camcorder which gives a brilliant pic at 10 lux. Recording/Playback times are: SP 90 min; LP 180 min.

The CCD-V8 must not be compared with the Betamovie. Beside its small size and lightness and an EVF, it will playback to a TV or VCR having UHF input (I am told a VHF output may be available soon), of any format. It only requires

the small RFU-85 adaptor to turn video into a TV signal. It plugs into the CCD-V8 and then into the TV or VCR and is tuned like any TV station. Also, a battery pack, ac pack/charger allows mains operation; with an adaptor supplied it also charges up to three batteries. A Sony P5-30 VC is supplied.

There is a very wide range of practical accessories that can be purchased, carrying case, shoulder rest, camcorder jacket, special mikes, battery belt for 90 min sessions or camera light, automatic editor, power/charger/RF converter, and if you wish to use it as a home VCR for timeshifting TV, there is a docking unit to make it into a tuner/timer with remote control.

For a recommended retail price of \$2199.00, the Sony CCD-V8 must be a very attractive purchase for the videographer; serious or novice. It is however, an electronic movie camera and does not record and timeshift TV (it will dock into the TT-V8EC Tuner/Timer and do this) if you own a home VCR you can use if for video shots, wherever you may be. You can then edit, at very high quality, onto any half inch VC or other video medium. Although the video format is of no consequence, the TV and VCR must be PAL if the camcorder is PAL; both NTSC if it is NTSC.

The home version of the V8 format VCR is deeply involved in PCM audio recording/playback with timeshift; from both TV and FM audio. It is a long subject in itself and I will cover it in a following article.

The theory and practice of V8 format sound; both FM Multiplex and PCM is a lengthy subject of great interest and complexity.

The 8 mm cassette is not for video alone. In the wings are applications for computer data storage, and a 'video photoprinter' to deliver colour prints from video frames. For audio applications, the 8 mm format is planned to provide a hi-fi record/playback media giving six three-hour tracks with specs to challenge the compact disc. ♣

# ADMARKET

Readers' free adverts.

READERS-CLUBS-ASSOCIATIONS

WE'LL PUBLISH your advertisement of up to 32 words (maximum), totally free of charge. Either fill out the coupon here, or write or type it out on a clean sheet of paper. But **please** make it legible, other wise it may not turn out as you intended! Copy **must** be with us **six weeks** prior to the month of issue. Every effort will be made to publish you advertisement, but no responsibility for so doing is accepted or implied.

**CONDITIONS** You must include your name and 'phone number and/or address within the 32 words (for amateurs, 'QTHR' is acceptable). Accepted abbreviations such as DSD, 100 W RMS, ONO etc, may be used. Please include you name and full address plus 'phone number with a covering letter. **Private advertisements only** will be accepted. We have 'small ads' for traders, who should contact our advertising representatives.

Send your adverts to: **AEM ADMARKET**  
**Australian Electronics Monthly**  
**PO Box 289 WAHROONGA 2076 NSW**

.....	.....	.....	.....	.....	.....
.....	.....	.....	.....	.....	.....
.....	.....	.....	.....	.....	.....
.....	.....	.....	.....	.....	.....
.....	.....	.....	.....	.....	.....
.....	.....	.....	.....	.....	.....

# letters

## Hi-Fi ... where am I?

Dear Sir,

Developments in the electronic reproduction of music have moved so swiftly over the last 20 years or so that, had the average music lover held onto the various pieces of equipment and peripherals that he has bought or built, he would possess enough to furnish a small museum.

He would have a broadcast radio with terminals at the back to take a heavy magnetic pick-up, or perhaps a lighter piezo-electric head. He might even have a high quality AM valve tuner and a 10 watt Mullard amplifier with five valves and several enormous transformers. There would certainly be a collection of 78 rpm records, leading to 45s and 33 $\frac{1}{3}$ s with turntables to suit. He would have speakers in vented enclosures or folded exponential horns, perhaps some filled with sand if the house foundations would stand the weight. The birth of stereo meant another amplifier, another speaker and another enclosure, so add these to the list! There would be at least one tape cassette deck with cassettes and probably an old reel-to-reel recorder, surrounded by a collection of reels of various diameters. An early 'boxy' AM/FM stereo tuner would also be on display as a relic of the very recent past. There would be many stereo amplifiers.

Let us now pause in this recital of 'memorabilia in our time', before things really get confused by introducing compact discs and hi-fi video.

What has all this change done for us, apart from allowing us to start a museum of our own purchases?

The sound that we get from our speakers has undoubtedly got closer to that which goes into the microphone in the studio or concert hall. However, this sound is not always up to the quality of the equipment and many recent reproductions of music do not capture the 'presence' of earlier ones. So a good deal depends on the skill of the engineers doing the recording. And a good deal depends on how well we maintain our equipment. The cartridge, the stylus and the magnetic head all must be properly looked after.

Granted that sound is on the improve, how does one view the compact disc and hi-fi video?

Having built up our library of, for instance 78s and seen the means of spinning them disappear, will our 45s and 33 $\frac{1}{3}$ s go the same way? If we buy a CD player, will one that can make home recordings be released next year, or next week? Will the classical music catalogue

of CDs be built up or will rock and popular music consume the disc manufacturing capacity? Pre-recorded-music tapes seem to be improving tremendously. Will high quality tape players come down to the price of CD players? Someone, sometime must market a reasonably priced AM/FM stereo tuner that has good AM reproduction. When?

So what is the present situation?

The answer is that there isn't one. That was yesterday. How do we poor people who reckon we have probably spent enough for a while on equipment, judge the best move to make to use these developments to increase our listening pleasure?

One viewpoint is to go where the music is. That is, if you see an LP that you want, buy it; or a tape that takes your fancy, buy it. However, how do you feel when the same performance comes out on a CD next month?

The answer to that is, buy the CD player now and the discs as they become available. But CD players are improving with each generation, why buy one before you can really use it? And what about pre-recorded tapes? They are improving. Why not save your money and buy a next-generation tape player?

So there we go, or rather, there we stand, still in a state of confusion.

There are a few signposts that can guide us through the Valley of Confusion and these probably point to keeping as close a watch as possible on developments. For instance, an AM stereo tuner is now being produced by a major manufacturer, so someone is thinking of us! Some retailers stock a much wider range of CDs than others and could be well worth seeking out, and so on.

Well-informed, appropriate magazines are a good way to help you spend money wisely. Retailers can be useful, but beware of those who are interested more in the fast sale rather than a continuing customer relationship.

So perhaps all is not lost. Perhaps there is a way to move carefully through the quick-sands that lie in the Valley of Confusion!

Congratulations on your magazine. You are catering for a wide readership and I have found a number of your articles have opened up new avenues of interest.

Don Richards  
Eenezer, NSW

## Active speakers

Dear David,

Some time ago I wrote to ETI to sug-

gest future projects of interest to me. I then noticed AEM issue No. 1 at the newsagent and realised that you had left ETI. I also noted that you appear to be resuming the policy stated by Roger Harrison when launching the 5000 Series (1981).

This suits me, because my main interest is in audio projects of high quality. An important bonus is that your designs are flexible and allow the readers to use only the sections that interest them at that time and add later if desired. This enables us to have top quality equipment at minimum cost.

The other most important attraction of your projects is the manner in which you set out all the technical reasons for choosing various sections of your designs. You involve the reader in the same way the late John Moyle (Editor of Radio & Hobbies, later *Electronics Australia*) did years ago.

My particular problem at present is to choose a suitable mid-range amplifier for my existing three-way speaker system. I use a Series 5000 amp for my very efficient 15" Wharfedale bass unit, my old Williamson valve amps for mid-range and a 10 W valve amp for treble. I use the old ETI-433 active crossover, which I later altered to use NE5534ANs instead of the original TCA220s.

The problem is that, according to the review of John Bowers' Active 1 loudspeaker in the February '85 issue of *Gramophone*, the effects of signals generated by the moving coil speakers is much more audible when feeding a single speaker than with multiple drive units fed via passive crossover networks, which seem to absorb these signals. The effect is described as a "slightly brittle, aggressive mid-range".

John Bowers considered the choice of a very low output impedance using multiple, paralleled MOSFETs with little or no feedback, as in the highly regarded but expensive Sony Esprit, but settled for a less costly variation using vertical power MOSFETs (VFETs — Ed.). The review itself is well worth reading.

From this, I gather that I should choose an AEM6500 100 watt amp. (July '85 issue). But, is the feedback too high for my particular requirement? I am using KEF B110B 8 ohm mid-range speakers and don't use many watts for my normal listening.

Would it be an advantage to add 8 ohm heavy duty resistors or other load to help soak up these signals from the drive unit voice coil? Would higher bias current help? Could I use less feedback when it is for mid-range use only?





However, I also notice you will be publishing a new AEM6000 amp, which might suit my application.

I will eventually replace the treble amp when I find a high quality amp which will not damage my expensive KEF T52B tweeters. I feed the tweeters via 25 uF capacitors to avoid faults causing LF reaching them. This value is sufficiently high to avoid phase shift at 3 kHz and above. The amp has suitable load resistors connected to it.

I trust your new magazine will be very successful.

**R. E. Ramsay**  
North Balwyn, Vic.

It sounds like you are developing a very interesting active loudspeaker.

I am in some doubt that the ratio of powers for the three amps is optimum at present. I imagine that the 15" Wharfedale would be somewhat more efficient than the B110B or T52B. So, I would suggest a 50-60 W amp for the mid-range and at least 40 W for the dome tweeter.

Having not read the review of John Bowers' active speakers as yet, it is difficult for me to comment on his findings. My work with active crossovers in the past, however, has led me to the opposite conclusion. In general, I have found that single drive units, driven from individual power amplifiers give substantially smoother results than when a passive crossover is used. The key of course is that the power amps used must be able to cope with the back-emf generated by the drivers without any trace of instability.

It is true that some manufacturers are adapting the "low or zero overall negative feedback" approach in power amplifiers in order to try to ensure that the output load does not cause amplifier instability. These designs obtain a low output impedance usually by employing a large number of parallel output devices rather than negative feedback to ensure output signal voltage integrity. In my opinion, the relative merits of this design approach is still unclear.

I would point out, for example, that at least one commercially manufactured "zero overall negative feedback" amp of which I am aware still uses the same amount of overall negative feedback within the voltage gain stages driving the output stage. The negative feedback take-off point is simply moved to an earlier point in the power amp and is therefore buffered from the load.

Unless your Williamson valve amp is suffering from load-induced instability, I do not think the addition of 8 ohm series resistors will help performance. This

would increase the effective output impedance as 'seen' by the driver and could have detrimental effects on sound quality.

The AEM6500 modules are highly stable units and ideally suited to this application. In fact, one of the reasons for their development was for use in an active loudspeaker, soon to be described in AEM. We will also be describing a new active crossover design that could be of interest to you.

Good luck with the project.

**David Tilbrook**  
**Geoff Nicholls**

## Satisfaction

Dear Roger,

Congratulations. You have done it for three issues now, with a great mix of articles. The field is so wide it would be easy to try to cover it all and please no one!

Your September editorial expresses amazement at the sophistication of all the electronic things we take for granted, but the real joy of these things is that they are so cheap once the initial demand has been met. The watch, calculator and computer are good examples. CD players and VCRs are currently displaying this downward price trend, now the "bells & whistles" stage has been left behind.

I have seen 'wonders of the age' that promised much and then quietly disappeared.

The real satisfaction of electronics remains with that band of people with not enough dollars and a hot soldering iron. My past has many memories of crystal sets and octal valves. My motto has been "never mind the theory — make it," then the theory becomes more understandable.

**Bruce Huston**  
Wellington, NZ.

## Headphones amp

Dear Mr Tilbrook,

Congratulations on your new publication!

At last I have acquired your Series 5000 power amplifier via Jaycar and am very pleased with it. However, I listen a lot through headphones late at night and no one has produced a circuit for a headphone driver.

After two hours playing at low level, you would not be able to keep your hand on the amp's heatsink for very long. Is this normal?

My preamp is a Marantz SC 500 which has an output of 1.5 volts/220 ohms @ 1000 Hz and feeds my Sennheiser 420 headphones adequately if I exer-

cise the volume control close to maximum.

I would like to ask you for a properly designed circuit for a headphone driver to be fed from the preamp. Something similar to the ETI-462 is the type of thing I am after.

**D. Griffin**  
Mossman, Qld

Regarding your Series 5000 heating problems, it sounds like you have the output stage bias current set too high. The on-resistance of power MOSFETs is somewhat higher than equivalent bipolar, so for the same output power from the power amp, the MOSFETs will dissipate more power and thus get hotter.

The heatsinking provided on the 5000 power amp is adequate to keep the temperature at a reasonable level. The prototype 5000 power amp, for example, runs at about 15°C above ambient after an extended period of operation. I suggest you re-check the bias current when the amplifier is hot to see what's going on. If the bias current is alright, the other possibility is that the amplifier is marginally unstable (caused by inductive MOSFET source resistors) and is bursting into oscillation. This is usually accompanied by noticeable distortion, however, so I would doubt that this is the problem in your case.

We have developed a headphone amplifier that will be described as part of the AEM6000 range of ultra-fidelity amplifiers. Initially, it is planned to use it in the "preamp extension" to accompany the 6010 preamp, but we will also plan to describe it as a separate project.

**David Tilbrook**

## Back issues

Dear Roger,

Congratulations to both you and your staff for a very well prepared and presented magazine. Australian Electronics Monthly has demonstrated that good technical journalists are alive and well in Australia. Please add another three readers to your growing list of converts. Good luck to you and to AEM

PS: Could you please advise if back copies are available (we have from September, on) and if so at what price?

**Paul Boekenstein**  
Sawtell, NSW

Back issues of AEM are available for \$3.60, post paid anywhere in Australia, A\$4.60 (airmail) to PNG or NZ. Note that the August 1985 issue (No. 2) has already sold out!

# The Last Laugh



HAVE YOU STRUCK a talking lift yet? If not, then you're in for a treat. The National Roads & Motorists Association (NRMA) headquarters in Clarence St. Sydney has one. Having pressed the "up" button to call a lift, when one arrives, the doors open and a speaker announces in digital tones, "going up!" As you ride the lift, it announces each floor as well as announcing "going up" or "going down" before proceeding after taking on passengers at a floor. It's all much more sophisticated and "up-to-date" than those boring old flashing lights alone.

This particular lift seems to use a National Semiconductors Digitaltalker speech synthesiser, which produces quite creditable, though still obviously digital, speech. However, the surprising thing is — people actually talk back to it! Whether they believe, or maybe suspect, there's an animate or half-way animate 'thing' behind the machine, we don't really know. But, it's fun to observe people's various reactions.

There are a variety of reactions, actually. Not everybody talks back. Some travellers pretend it doesn't exist. Some nervously laugh in embarrassment and glance slightly either

side — just checking out what's going on. The obviously gregarious folks strike up a conversation with it.

A colleague rang one day, having just rode up and down the NRMA lifts for an hour or so watching people's reactions, to ask if I knew technical details. Having satisfied his curiosity there, we then discussed our observations. Jokingly, we mused over a speculation of his as to what would happen if the machine actually appeared to be capable of holding an interactive conversation. After some hilarity, he rang off.

Weeks later, he burst into the office and grandly announced, "I've got it!" Naturally puzzled, "got what?", I enquired. "The interactive talking lift", he replied.

He had concocted a small piece of electronic wizardry which made the voice sound just like the Digitaltalker speech synthesiser. Adding a throat mic, a small battery-powered amplifier and a loudspeaker concealed in his jacket's breast pocket, he was going to have some fun in the talking lift!

Being a keen observer of human behaviour, your correspondent decided to accompany

said colleague on a 'test run'. He'd found a sizable, new downtown office block sporting a similar Digitaltalker 'talking lift' and suggested this would be a good place for a fun try-out.

Pretending an air of non-acquaintance, we entered an empty lift, pressed the button for the top floor, and retired to the rear of the lift. "Going up", echoed the two 'speech synthesisers' in unison. His timing was good, to say the least, I mentally noted.

Our first 'mark' got on at the second floor; a gentleman of some largish proportions. As the lift gently jerked into motion, after announcing "going up", my colleague followed with "my, we need to lose a little weight, don't we?" The victim looked up at the lift's indicator panel, looked quickly and nervously left and right and appeared distinctly uncomfortable.

"Not very tactful, is it?", my colleague enquired of the poor victim (in his speaking voice, having put his electronics on standby). "Damned computer things", the victim muttered, "bloody things are everywhere". He promptly punched a button and quickly got out at the next floor.

The next victim was a young lady of the 'outrageous punk' persuasion. She sauntered into the lift and pressed the ground floor button. "Going down", said the lift, swiftly followed by my colleague's comment — "What a lovely outfit, ma'am".

"Bullsh...!", screamed the girl, aiming the invective at the indicator panel before whirling to glare at us. Genuinely, we managed to look suitably startled. She flung herself out at the ground floor muttering something about techno-capitalist plots to undermine and enslave the proletariat... etc, etc.


We had some amusing 'conversations' with little old ladies, startled staff members etc, apart from a few members of the 'stiff upper lip' brigade who pretended it wasn't happening, whatever the provocation.

Late in the afternoon a distinguished, conservatively suited gent strode into the lift which was then on the top floor. He gave us a cursory glance, a slight nod, then turned and pressed the ground floor button. "Going down", said the Digitaltalker. Leaving a slight pause, my colleague's 'synthesiser' burst forth with — "Going a little thin on top are we, sir?"

His head snapped back as he looked up for the source of the comment. Then he turned to us, his blushing and furious face taking us quite by surprise with the force of emotion. "That damned insolent engineer in R&D's behind this. I'll fix his bunny tomorrow!", he thundered. The lift then stopped at a floor, whereupon he stormed out, ignoring the Digitaltalker's "floor seven" incantation.

As the lift slid down from the seventh to the sixth floor, we could hear his furious hammering on the closed liftwell doors as he realised he'd disembarked too early.

We beat a purposeful retreat at the ground floor, heading for the relative safety of an up-town coffee shop.

Incidentally, we know of a somewhat puzzled electronics engineer looking for a suitable position in R&D. Any offers? 



# Test us..

No matter what you're after in a multimeter, Parameters has it. Top value digitals and analogues, clamp meters and probe testers.

All digital meters feature  
 ● Easy to read LCD displays ●  
 Overrange and low battery indicators ●  
 Overload protected on all ranges ●  
 10A current ranges ●  
 Diode test ●  
 Complete with case and probes ●  
 12 month no-nonsense warranty

**1. 7040 3½ digit DMM**  
 33 ranges  
 0.1% DCV accuracy  
 \$99.00

**2. 7080 3½ digit DMM**  
 37 ranges  
 0.1% DCV accuracy  
 Capacitance measurement  
 — Hfe measurement  
 \$128.80

**3. 8040 4½ digit DMM**  
 31 ranges  
 0.05% DCV accuracy  
 Hfe measurement  
 Audible continuity test  
 \$201.25

**4. CM100 Capacitance Meter**  
 3½ digit, 0.1% accuracy  
 8 ranges 0.1pF-2000µF  
 \$171.35

**5. 260 Clamp meter**  
 AC current to 1000A  
 AC 750V, DC 1000V  
 Resistance to 2MΩ  
 Diode test  
 \$194.35

**6. 2010BZ multimeter**  
 24 ranges, 20,000Ω/VDC  
 Continuity buzzer  
 \$39.68

**7. 5050E FET multimeter**  
 43 ranges including 0.1µA  
 DC and 12A AC  
 Input imp. approx. 10MΩ  
 Polarity reversal switch  
 \$85.68

**8. 2447 Circuit tester**  
 A convenient probe-style multimeter.  
 12 ranges + continuity test  
 DCV, ACV and resistance  
 \$108.10

## Parameters Pty Ltd.

SYDNEY: Centrecourt, 25 Paul Street Nth., North Ryde 2113. (02) 888 8777.  
 MELBOURNE: 1064 Centre Road, Oakleigh South 3167. (03) 575 0222  
 ADELAIDE: Trio Electrix (08) 212 6235. BRISBANE: LE Boughen & Co. (07) 369 1277.  
 HOBART: Imbros (002) 34 9899. NEWCASTLE: DGE Systems (049) 69 4242.  
 PERTH: W.J. Moncrieff (09) 325 5722. TOWNSVILLE: Nortek (077) 79 8600.  
 CAIRNS: Thompson Instrument Services (070) 51 2404.  
 WOLLONGONG: Macelec (042) 29 1455.



Due to currency fluctuation prices are subject to change without notice. All prices are recommended only and include sales tax. Tax free prices on request.

# B & W DIGITAL MONITORS



## LISTEN AND YOU'LL SEE

The new DM100 series are built to the same exacting standards as the monitors we supply to major digital recording studios throughout the world. They are, happily, much more affordable. At around \$399 for the DM 100, and up to

\$999 for the DM330, you now have a perfect excuse to upgrade your equipment to digital standard.

Ask to hear them soon.  
Close your eyes and listen.  
Then you'll see.



AS USED BY DIGITAL STUDIOS WORLDWIDE. AND SOON, WE HOPE, BY YOU.

Distributed by: Convoy International Pty. Ltd.  
400 Botany Road, Alexandria, NSW, 2015.  
Telephone 698 7300. Telex AA23111.