

WIRELESS WEEKLY

Registered at the G.P.O., Sydney, for

transmission by post as a newspaper.

VOL. 6. No. 5.

FRIDAY, MAY 29, 1925.



Why Waste Money
BUYING

Dry "B" Batteries?

Instal a
"PHILCO" Re-chargeable "B" Battery

WHICH WILL LAST FOR YEARS

For FREE ILLUSTRATED CATALOGUE ask
your nearest Radio dealer or apply direct to

NEW SYSTEM TELEPHONES PTY. LIMITED

280 Castlereagh Street

25-27 Queen's Bridge St.

SYDNEY

MELBOURNE

M 3230

Phones

Cent. 11130

PHILCO
DYNAMIC RADIO
BATTERIES

FEATURE:

The
Modified
Crystotrap

VL

JEFFERSON Super-Sensitive Amplifying TRANSFORMERS

Putting
QUALITY
into
RADIO

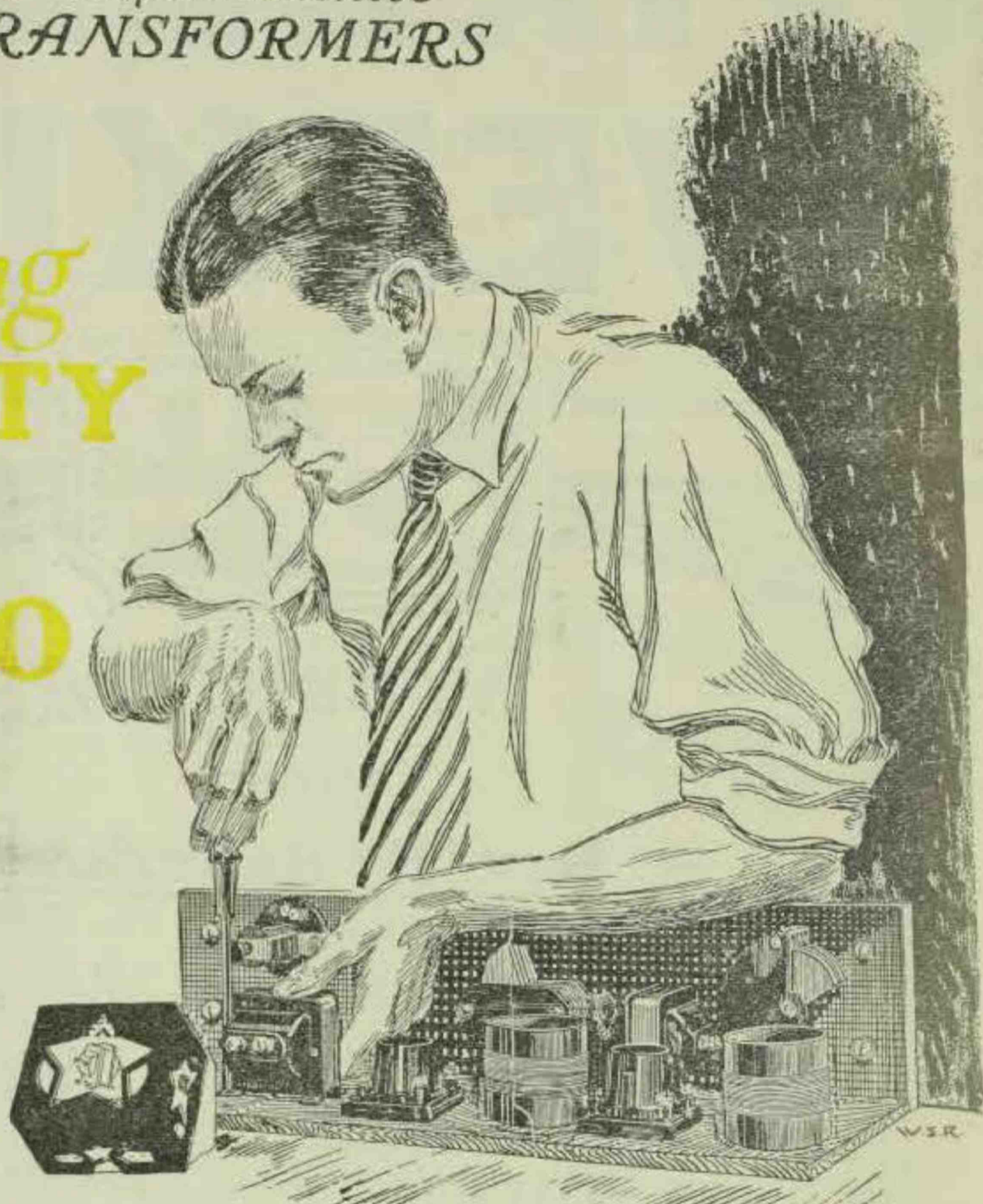

NEW PRICES:

On and after the 7th instant the Retail Prices will be :

"Star," 3 to 1 Ratio	-	-	-	21/-
No. 41 3.75 to 1 ratio	-	-	-	27/6
No. 38, 6 to 1 ratio	-	-	-	35/-

FOX & MacGILLYCUDDY LIMITED

Daily Telegraph Buildings, Sydney

Brisbane Agents: Wireless House, Adelaide Street, Brisbane

SET £20

COMPLETE £40

MODEL
W.E. 4**CASE**MODEL
W.E. 4**FOUR VALVE RECEIVING SET**

AUSTRALIAN MADE

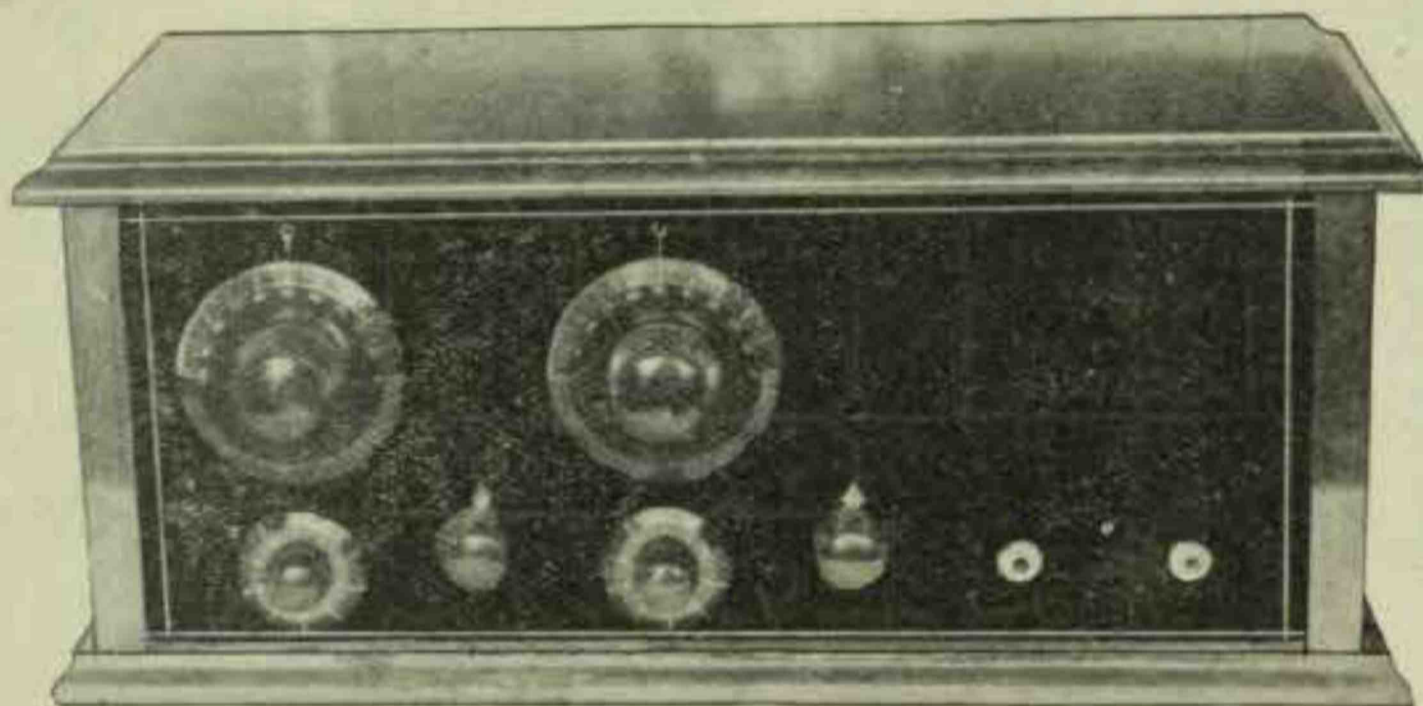

100% Standard Advertised Parts of the Highest Quality.
UNCONDITIONALLY GUARANTEED.

The CASE is a genuine musical instrument embodying simplicity of radio construction, coupled with the latest practical engineering achievements.

Profiting by the experience of set builders throughout the world, has assisted in the development of this perfect instrument, at a price unheard of throughout Australasia.

This WONDER SET is equipped to reproduce high and low wave lengths with selectivity, clarity and volume on a loud speaker, under accurate two dial control. It is enclosed in an attractive, high maple finish cabinet.

Genuine Bakelite Dilecto, machine finished front and sub-panels, sockets, machine installed in sub-panel, concealed wiring, no coil changing, no excess wiring, parts, dials, or knobs; no disturbance to neighboring sets.

Inspection cheerfully invited. Demonstration given without obligation.
If your dealer or wholesaler has not stocked the CASE, communicate direct with the

SOLE AGENTS

O. H. O'BRIEN (LATE O'BRIEN and NICHOLL) **37-39 PITT St.**

516 COLLINS STREET, MELBOURNE.

An Excellent TWO VALVE RECEIVER

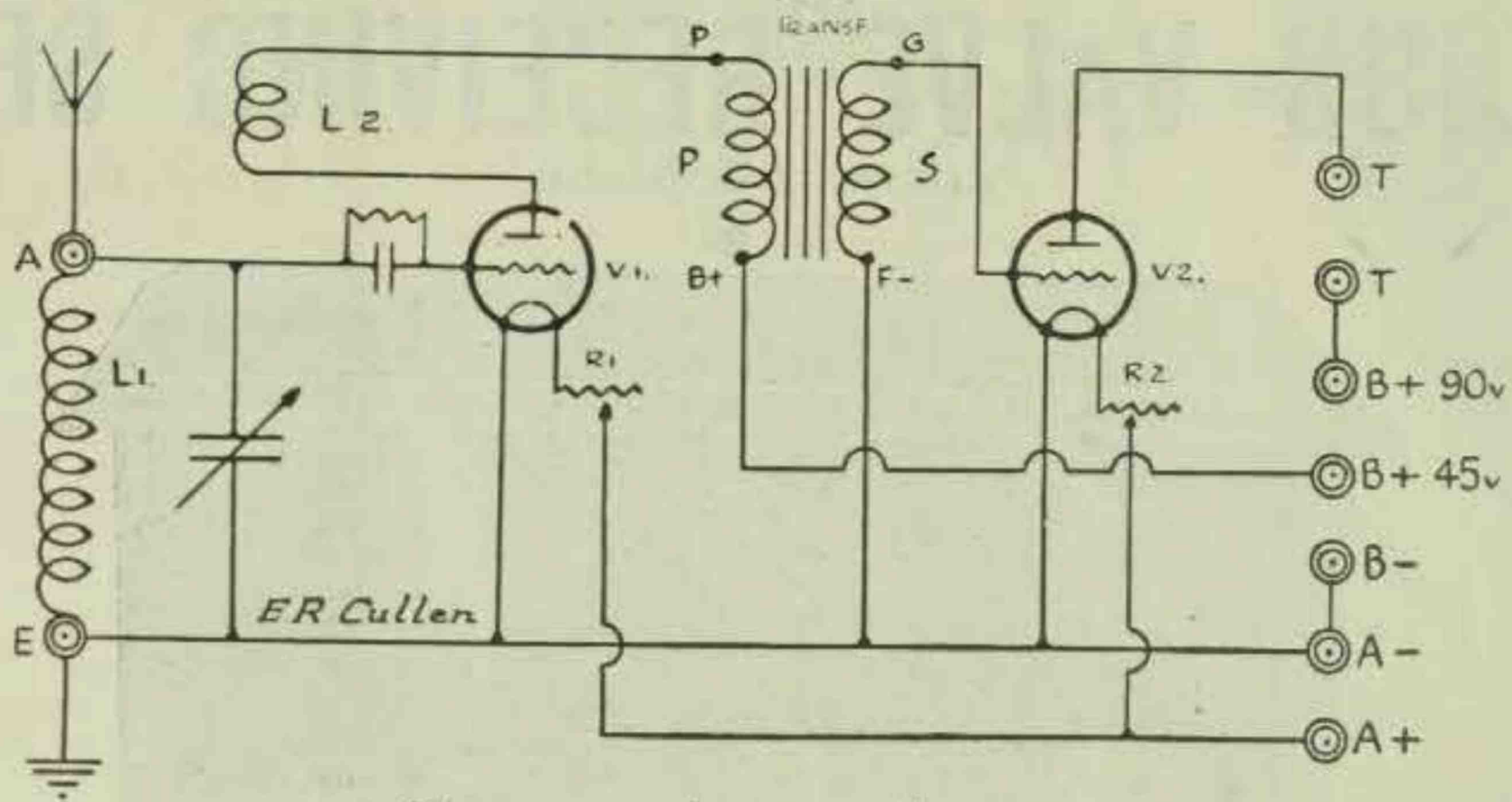

P. 1 WITH 1 STAGE AUDIO.

This week, in response to numerous requests, we publish an excellent two valve receiver circuit that is commendable for its simplicity of design. Only one condenser is necessary.

Though not primarily designed for loud speaker work, this receiver, if constructed of dependable apparatus, will give fair results within a range of ten miles of a broadcasting station.

To the enthusiast, whose distance from the broadcasting station is just too great to allow the use of a single valve set, this receiver should particularly appeal.

Separate B Battery tappings are taken in order to get the utmost from the valves. Using UV 201a, C 301a, or DV3 de Forest valves, the voltages given will be quite satisfactory.

MATERIALS RECOMMENDED.

1 Radion Panel, 12 x 7 1/2 x 3/16	9	5
1 De Luxe Two-coil Holder	9	6
1 .001 Master Variable Condenser	1	7 0
1 Signal 7 1/2 to 1 Transformer	1	1 0
2 Frost Rheostats	11	0
1 Wetless Grid Condenser and Leak	3	9
2 Hoosick Valve Sockets	8	0
9 Engraved Terminals	4	0
9 Bus Bars	1	8

Honeycomb or Spiderweb Coils will function admirably. We recommend Cullenola Coils, the most efficient on the market. Yet prices are no more than those charged for ordinary coils.

AMERICA BRAND CONDENSERS.

We repeat our announcement of last week in connection with the arrival of stocks of the wonderful America Brand Geared 100 to 1 Ratio Condenser in the three sizes. Prices are—

.001	37/6
.0005	32/6
.0003	30/-

E. R. CULLEN, Late A.I.F.

Radio and Electrical Store

96 BATHURST STREET :: Tel. City 869 & 2596

Brunet Transformers

Amplify Perfectly

PRICE
21/-

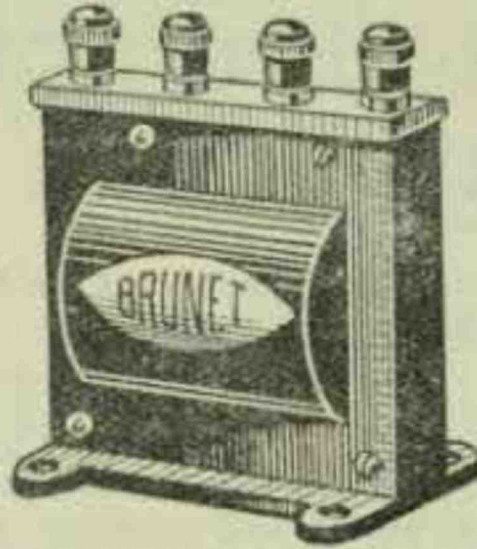

To have earned the goodwill and continued patronage of no less authorities than the Radio Services of the French Army, Navy and Air Forces is an achievement worthy of special mention. This alone is selling argument sufficient to prove that Brunet Transformers are entirely satisfactory and perform in a manner that ensures perfect results. Brunet Transformers here illustrated, are what is known as the shielded type — giving protection from external stray currents—the amplification of the broadcasted sounds is thus assured with no distortion. Brunet Transformers are fitted with low-loss coils, and terminals are complete with ebonite knobs. Every Set should boast that it is fitted with Brunet Transformers. Price, 21/-



The Best —

"TUNAWAVE" Honeycomb Coils

These wonderful Coils are finding enthusiastic supporters all over Australia. Be wise and fit them in your Set. Made in all sizes for all Sets.

No. of Turns	Unmounted	Mounted
25	2/2	5/3
35	2/2	5/3
50	2/4	5/6
75	2/6	5/9
100	2/9	6/-
125	3/-	6/3
150	3/-	6/6
175	3/3	7/-
200	3/6	7/6

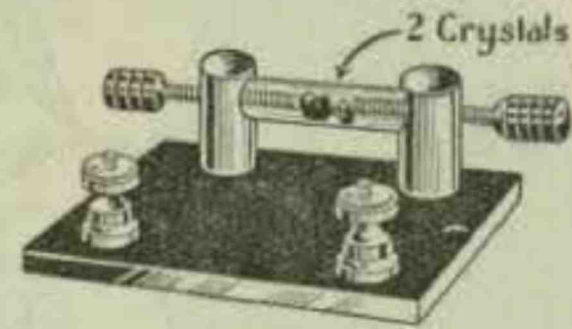

PERFECT — "TUNA" Perikon Detector

Perfect!—that is how the Perikon Detector is being praised by satisfied owners everywhere. The most attractive point about the Perikon is that there is no longer any necessity to hunt for a sensitive spot—all you have to do is to bring the two crystals (Zincite and Bornite) gently together to get a permanent sensitive contact. It may be fitted successfully to Crystal sets or any Reflex Valve circuit.

Price, everywhere - 4s. 6d.

Refills, consisting of one piece of Zincite and one piece of Bornite, in sealed tube, may be had for 1/6 each.

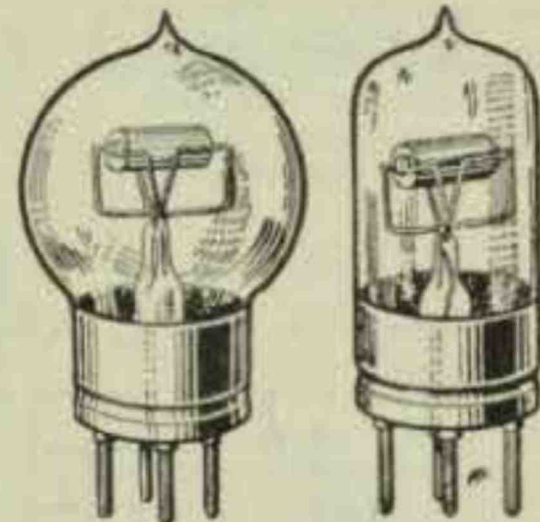

New Dutch Valves 9/6 ea.

These new Dutch Valves are now obtainable—both the Detector and Amplifier type—everywhere at the amazing price of 9/6 each. Although far below the price of competitive lines, they give results equal to the best of Valves. You should see about these Valves today. Remember 9/6 each.

CORBETT, DERHAM & CO. PTY., LTD.

231 CLARENCE STREET, SYDNEY.

MELBOURNE, SYDNEY, BRISBANE, ADELAID E. LONDON, NEW YORK, CHICAGO.
REPRESENTATIVE FOR QUEENSLAND: WAL TER F. DENBY, 80 EAGLE ST., BRISBANE.

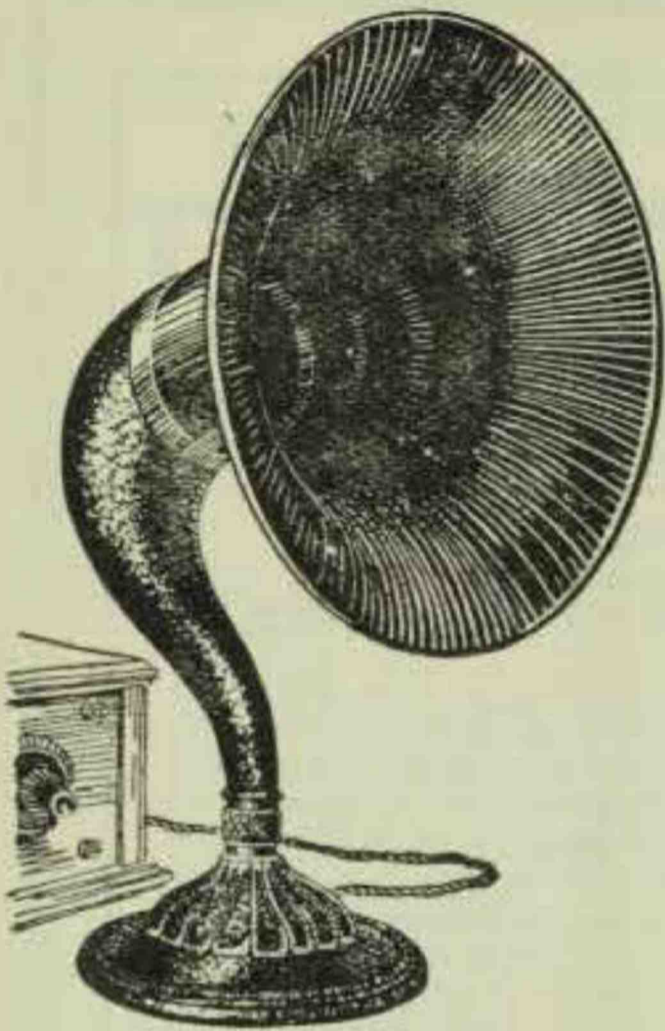

Loud Speakers

that give you radio as you **OUGHT** to hear it!

Whatever your individual desires are regarding Loud Speakers you will be able to realise them all if you make your selection from those listed here.

MUSIC MASTER LOUD SPEAKER.—This has a resonant wood amplifying bell which neutralises all mechanical effects and produces a remarkable volume of clear, pure tone, free from muffling or distortion—a life-like re-creation of the original. As illustrated above
£12

ATLAS LOUD SPEAKER.—The "Musician of the Air." Its scientific design, with careful fabrication and assembly, goes far to compensate for any shortcomings of broadcasting. It gives you the programmes clearly, sweetly and naturally £7/10/-

SIGNAL LOUD SPEAKER.—Of special shape and construction, as illustrated on top of Radiovox Cabinet at foot of page. Strong and sweet £4/15/-

BRANDES TABLE TALKER, known the world over—
£4/15/-.

All Radio Dealers can supply you at These Prices
United Distributors Limited

WHOLESALE ONLY
72 Clarence Street SYDNEY. 592 Bourke Street MELBOURNE.
and at Brisbane, Adelaide, Perth, Hobart, Wellington.

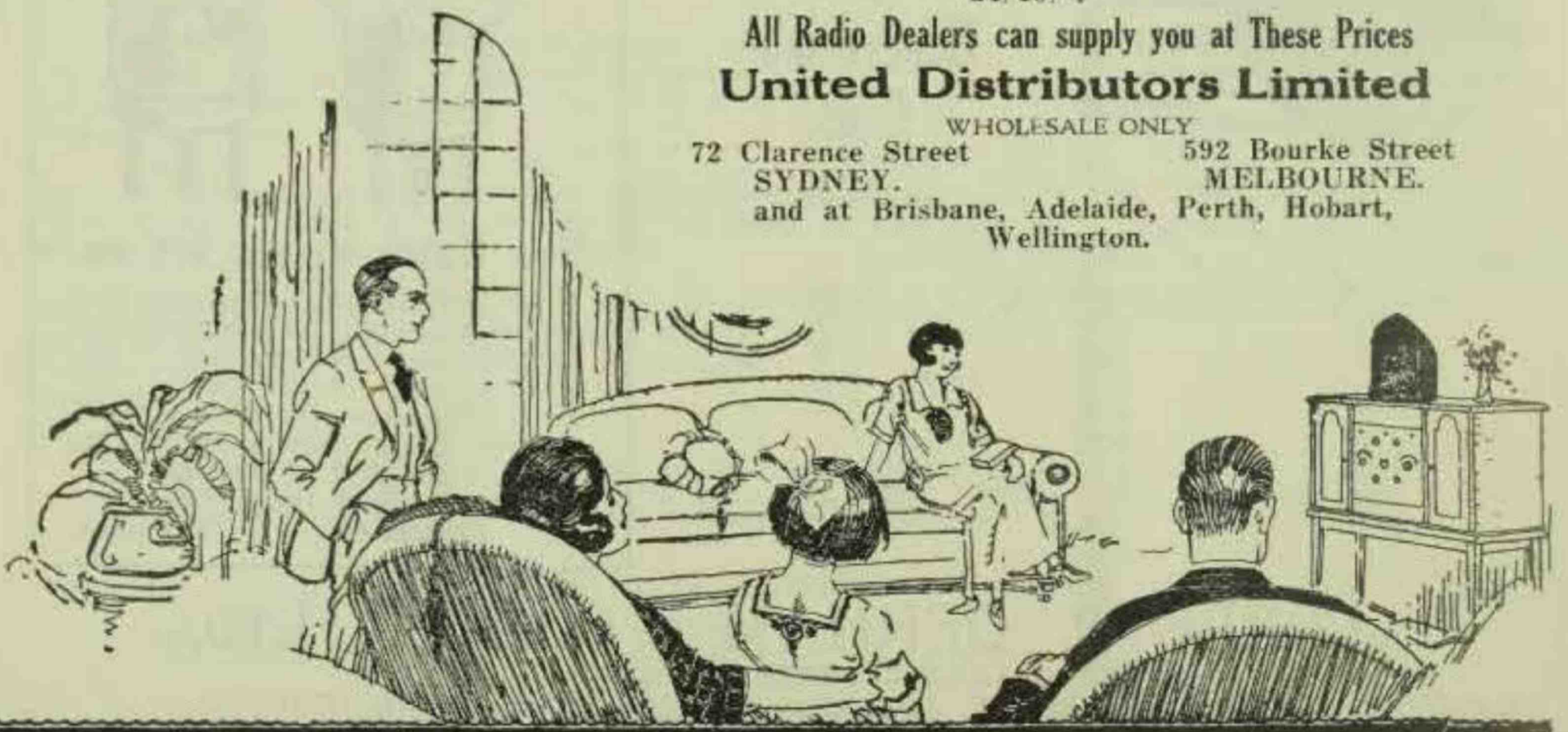

There's joy for all the family if you have a Loud Speaker on your set.

They can all hear the programmes perfectly. There's no bother with head-phones—just cool comfort and perfect pleasure.

*We have pleasure in Announcing the arrival of
Fresh Stocks of*

ACME ^{LOW LOSS} Condensers

AT ALL **48/6** GOOD STORES

JUST ARRIVED

“BLACK BEAUTY” SPEAKERS

These Speakers are offered with the conviction that they
are BETTER VALUE than any other Loud Speaker
Regardless of Price

Everywhere **75/-** Everywhere

WE HAVE JUST OPENED UP STOCKS OF

E. T. Flewelling Low Loss Condensers

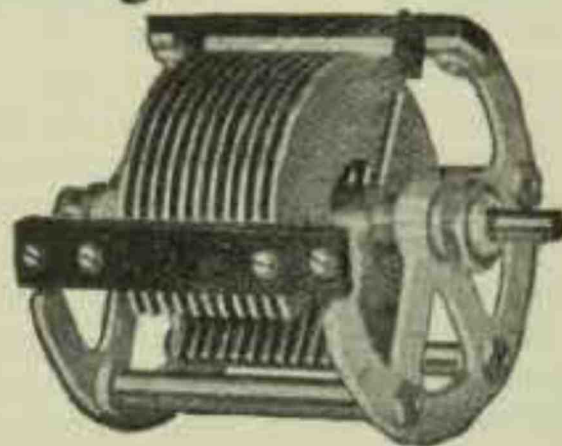

MADE BY THE
FOREMOST LOW
LOSS AUTHORITY

IN THE
UNITED
STATES

Price - .0005, 32/6. .00025, 30/-

Wholesale
Only

P. H. CLARK LTD.

Phone: City 8469
Box 914, G.P.O

38-44 CARRINGTON ST. SYDNEY
Our Agents in other States:

VICTORIA: W. N. Bartholomew, 380/382 Flinders Lane, Melbourne.

QUEENSLAND: Colin Campbell, "City" Buildings, Edward St., Brisbane.

SOUTH AUSTRALIA: Cedric Wright & Co., "Hayward" Buildings, Charles St., Adelaide.

ACME ——— WALNART ——— HILCO ——— LINCOLN LOOPS, Etc.

Wireless Weekly

12-16 REGENT STREET, SYDNEY, AUSTRALIA.

'Phones: Redfern 964 and 930.

MELBOURNE OFFICE: A.P.A. Building, 49 Elizabeth St.
'Phone: Cent. 8955.

Official Organ of the New South Wales Division of the Wireless Institute of Australia, with which are incorporated the Affiliated Radio Societies and the Australian Radio Relay League.

Editor: A. W. Watt.—The Editor will be glad to consider Technical and Topical Articles of interest to Australian Experimenters. All Manuscripts and Illustrations are sent at the author's risk, and although the greatest care will be taken to return unsuitable matter (if accompanied by stamps), the Editor cannot accept responsibility for its safe return.

"Wireless Weekly" is fully protected by copyright, and nothing that appears in it may be reprinted, wholly or in part, without special permission. The use of our articles or quotations from them for any purpose whatsoever is never authorised.

VOL. 6 No. 5

MAY 29, 1925

Editorial.

MORE STATIONS.

WITHIN the next few weeks, the power of the "B" Class station 2UW is to be increased to 500 watts, thus bringing it into line with our two "A" class stations. In addition to this, it is reported that two great political parties each propose to operate a "B" station, so, as the regulations provide that a proportion of the hours of service must be devoted to musical items, there is promise that there will shortly be a far wider field to explore than listeners-in have hitherto enjoyed. The early linking of the Bondi Casino, possessing one of the finest and most popular orchestras in Sydney, with 2UW, demonstrates two things—that 2UW is anxious to provide the best possible service, and that the management of the Casino are fully alive to the Publicity value of broadcasting.

Who amongst us, having heard portion of a good theatrical entertainment broadcasted, but did not itch to see the artists themselves and to witness the actions which prompted the bursts of merriment and applause, faithfully reproduced by the microphone?

It has long been recognised abroad that broadcasting is one of the finest methods of publicity it is possible to get. Some of the greatest artists in England and America consider it essential to occasionally face the invisible audience beyond the broadcast studio, and the number of budding Melbas and Kreislers who yearn to try themselves out is legion. Publicity is the dominant thought

behind the desire of these people to be broadcasted and the question of monetary remuneration does not enter into the matter—or at least, very rarely.

This fact cannot be overlooked—that an artist who can win the approbation of a broadcast audience is indeed a true artist, because it is one's art alone that is judged and not the individual. There are no little mannerisms, no scenic effects, no spot lights or dainty frocks to help put it over. Between the artist and the audience there is a barrier penetrated only by the waves generated at the broadcasting station and the highest tribute any artist could win is that of the listener-in who puts down his phones after an item and says, "That was good."

The artist who earns the praise of thirty or forty thousand listeners-in has little to fear from the visible audience across the footlights.

AMATEUR OPERATORS' CERTIFICATE.

THE number of replies to the question published in Wireless Weekly quite exceeded our anticipations and convinces us that, in preparing the series of instructional articles which are now running, we are fulfilling a very definite need on the part of a large number of readers who are anxious to advance their knowledge and to progress beyond the stage of listening-in.

Much time and thought have been spent in the preparation of the articles, and we have tried to confine the matter to those points which may reasonably be expected to be covered in a Government Examination, also to deal with matters as plainly as possible.

It should be pointed out here that, when a transmitting license, or as it is now known, an Amateur Operator's Proficiency Certificate is approved of by the Chief Manager of Telegraphs and Wireless and the certificate is issued; the licensee may go right ahead with his station.

From some of the mail we get, it would appear as though there were an impression that the application must also be approved of by the Wireless Institute. Such is not the case, as the Institute is purely an amateur organisation of which by the way, it is highly desirable that the newly licensed transmitter become a member.

The commencement of the Morse Code practise next week will mark a further step ahead in the progress of those who are looking forward to one day operating their own transmitting stations.

To those who have not bothered to send in the answers to the questions we have published we extend the hope that they will do so, as it will enable them to ascertain how far ahead they are.

Next week a special article will show clearly how to tune in to 2WW for the Code lessons.

Brandes

The Name to Know in Radio.



*Result of 16
years' experience*

If you have any difficulty write for name and address of nearest Brandes dealer to:

Amalgamated Wireless
(Australasia) Ltd.

"Wireless House"
97 Clarence Street, Sydney

"Collins House,"
Collins Street, Melbourne

Sole Agents for Australia and
New Zealand

Price 35/-

Trade
Enquiries
Invited

Grandpa "sleeps in them"!

Again we found him deep in the companionship of "Brandes" and this time actually asleep, chin on breast, and with the beloved pipe drooping listlessly between his lips. He laughs now, and says it only goes to prove the worth of these famous headphones. So comfortably do they fit to the head, so light that one is not conscious of them, their full sweetness of tone is such that it is no wonder he dozed under their soothing influence. Try Brandes "Matched Tone" Headphones for comfort and perfect reception—any good Dealer has them.

Matched Tone
TRADE MARK

Radio Headphones

HEADQUARTERS
Royal Society's House
5 Elizabeth St
SYDNEY, N.S.W.

Wireless Institute of Australia

N.S.W. Div. Inc.

Incorporating the Affiliated Societies and The Australian Radio Relay League



W.L. Carter, Hon. Sec.
Box 3120 G.P.O. Sydney
Phone B2235
A.H. Ferrett, Publicity Officer.

Ultra Short Waves.

The monthly general meeting of the New South Wales Division of the Wireless Institute of Australia was a pronounced success in every way. The subject of the lecture was "The Reception and Transmission of Ultra Short Waves," meaning thereby waves below 5 metres in length. Mr. H. K. James handled his subject excellently, and all the work that he has done came as a surprise to many members. He outlined the difficulties that are experienced in this class of work, and gave some very valuable hints as to the best method of procedure. He pointed out that on a wave length band of from 1 to 3 metres it was possible to place twenty thousand broadcasting stations with less fear of interference than is experienced at present. By means of diagrams on the board the lecturer showed how each circuit can be adapted for short wave work, and the simplicity of the apparatus was amply demonstrated by an actual transmitter operating on the lecture table.

After dealing very thoroughly with the various methods of keying these short waves, Mr. James proceeded with the question of modulation. He explained the difficulties and the coarse note which is obtained by the usual note. He then described the method that he had adapted, which consisted of super-imposing on the short wave, high frequency currents, a wave of longer length which is modulated by the ordinary methods employed by the experimenters.

In reception a superheterodyne principle was employed and this combination gave very good results. Members were delighted when Mr. James said he would build a transmitter which would work, and this he proceeded to do. The whole operation barely occupied five minutes, the simplicity of the apparatus being extreme. It merely consisted of clipping on to the points of an ordinary valve little sockets carrying the radio frequency chokes, and the necessary inductance, capacity and grid leak. The only operation that was not shown was the final one of suspending the valve by a piece of string. It was explained that this was

necessary as the capacity introduced by laying it on the table was quite sufficient to upset the working of the apparatus.

Measuring the Wave Length with a Foot Rule.

One of the most interesting parts of the lecture was that in which Mr. James actually measured the wave length of the set he was operating with a foot rule. The output of the transmitter was coupled to two wires stretched down the hall. By means of a short circuiting strap, the anti-model points were found. Correct measurements of the distance apart of these points gave half the wave length being employed, which proved to be 2.3 metres.

The Lecturer also mentioned his work in connection with beam transmission describing the parabolic reflectors used, and stating the results he had obtained.

The work accomplished by Mr. James with the Beam System was particularly commended by our President, Mr. C. Maclurean. The lecture was one of extreme interest, and Mr. Stowe, who is responsible for the papers presented before these meetings of the Institute, is certainly deserving of great credit for having arranged this lecture.

New Members.

At the Monthly General Meeting the following new members were elected to the New South Wales Division of the Wireless Institute of Australia. As full Member, G. W. Stewart; Country Members, G. W. Exton, and L. V. G. Todd; and as Associate Member, R. McE. Davis.

Moore Relief Fund.

Members are reminded that a quantity of gear belonging to the late Frank Moore, whose untimely death is regretted by the wireless fraternity, is available for purchase at Headquarters. The proceeds will go to swell the Moore Relief Fund. Some of the gear is extremely valuable and is well worthy of inspection.

Broadcasting.

The monthly broadcasting period allotted by Messrs. Farmer & Co. to the Institute will take place on Tuesday, June 2, from 7.45 to 8 p.m., when

Dr. W. G. Woolnough, D.Sc., F.G.S., will take for his subject, "The Advantages of Wireless to the People of the Outback." Members are invited to listen in and hear what the Institute is doing towards the amelioration of the conditions of those in the heart of Australia.

Research.

Details of the Institute's transmitter are being finalised and the list is available of parts required for this purpose. Members willing to donate any of the gear are invited to inspect the list, donate what they can, and then inspect the list again to see what else they can donate.

Military Wireless.

It is not yet too late to get into touch with Lieutenant Fry with regard to joining the wireless units of the military forces. Time is pressing, however, and this matter should be treated as an urgent one, if you have any intention of volunteering your services or of getting a transfer to these units.

QRM.

The Morse Code practice class is held on Tuesday, instead of Wednesdays.

Station 2GM is in fair order, but his note is rough. Other pressing business, however, has caused him to neglect the station somewhat of late.

2JT is scrapping all his old gear. It is now lying in a dejected heap in the corner. His new apparatus is very good, and the station shows signs of careful work.

The Publicity Officer has been making another tour of amateur stations. He only succeeded in taking home some mud from the Western Suburbs.

Still they come! Membership in the Institute is rapidly growing. We welcome all genuine experimenters.

A. H. PERRETT.

Publicity Officer.

Round the Clubs

The asterisk denotes clubs affiliated with the Wireless Institute of Australia (N.S.W. Division).

THE LEICHHARDT AND DISTRICT RADIO SOCIETY *

On Tuesday, May 19th, members of the Leichhardt and District Radio Society held their 128th general meeting in the club-room, 176 Johnston St., Annandale.

In spite of inclement weather, the attendance was excellent, and keen interest was taken by those present in the exhibition by members of home-made apparatus of various kinds. Items of spec-

ial interest were a novel valve holder for the "V24" and "Q" types, constructed by Mr. J. R. Alexander, portion of a very neatly constructed magnetic rectifier, and an aerial-earthing switch — both exhibited by Mr. W. G. Dick, a handy-looking interchangeable crystal detector, built by Mr. A. R. Levi, new type of low-capacity inductance evolved by Mr. E. G. Levi, and a specially made honeycomb coil wound by Mr. E. J. Fox. All the work exhibited was of a high order, and as each member had a few words to say regarding his own particular exhibit, the evening proved a very enjoyable and instructive one to all.

The Society will hold its 32nd monthly business meeting next Tuesday night, when applications for membership on hand, and other formal business will be dealt with. This will be followed by the 131st general meeting on June 9th, at which the 10th lecture of Syllabus No. 3 will be delivered by Mr. F. W. Sommers. The subject, "Lateral Communication During Wartime," will be a unique one as far as the Society is concerned, and should prove of exceptional interest to members.

The Society's experimental transmitting license has now been granted, and it is expected that the call signal allotted—2LH— will be vibrating the ether at an early date. Listen for it.

Inquiries regarding the activities of the Society are welcomed at all times, and these should be addressed to the Hon. Secretary, Mr. W. J. Zech, 145 Booth St., Annandale.

STRATHFIELD RADIO CLUB.*

The ordinary weekly meeting of above club was held at the club rooms, corner Albert Road and Duke Street, Strathfield, on Monday evening, 17th inst.

On account of the wet weather, and the fact that a number of our members are at present suffering with severe colds, the attendance was not very good.

For the same reason the lecturer for the evening was unable to attend, so our President, Mr. A. E. Jacob, very kindly consented to provide those present with interesting entertainment, in the form of a talk on the "Sydney Water Supply." As an engineer of many years' standing, in what a section of the press jocularly refer to as the "No Water Board," Mr. Jacob is in a position to understand some of the great problems which have confronted the Board in the past in providing an adequate water supply system, and he dealt with a number of them in his lecture, which was most enlightening and highly appreciated by members present.

As a pardonable diversion (taking circumstances into account) from the usual activities of the club,

With "Philco" your set will go.

which are generally confined to radio subjects, the lecture provided excellent entertainment.

At our next meeting Mr. H. C. Simpson has kindly consented to deliver a lecture on "Electrons," when it is hoped that he will be favoured with fine weather and the usual good attendance.

Some more parts were recently purchased for the club's new demonstration receiving equipment, the construction of which is proceeding at a satisfactory rate, and it is hoped to have it in operation within the next few weeks.

Inquiries regarding the club's activities, addressed to the Hon. Secretary, 44 Bayard Street, Mortlake, will receive prompt and courteous attention.

THE CROYDON RADIO CLUB.*

The meeting of the above club held on May 16th at the club rooms, "Rockleigh," Lang Street, Croydon, was a record for attendance. Mr. C. W. Slade presided and opened the meeting at 7.30 p.m. After the usual club business had been transacted nominations were received for the offices for the next twelve months. The election is to take place on Saturday, May 23rd. The feature of the evening was the display of apparatus made by our members who are competing for the valve donated by Mr. Walker.

On account of the quantity and variety of apparatus entered, the judges did not have time to test each article, so the awarding of the prize had to be held over until May 23rd. Amongst the various entries were audio transformers, magnetic rectifiers, wave-meters, coil holders, and a 20 metre transmitter. Mr. Pickering recently became the proud possessor of an "independent oscillator," and it is his intention, we believe, to match it against 2JT's 8 oz. bottle set. All correspondence should be addressed to the Hon. Sec., "Rockleigh," Lang Street, Croydon.

CONCORD AMATEUR RADIO CLUB*

The usual weekly meeting of the above club was held at the club-rooms, "Euripides," Wallace Street, Concord, on Thursday, 21st May.

The President, Mr. J. V. Stevenson, occupied the chair, and opened the meeting at 8.5 p.m.

After the attendance of the past few weeks it was very encouraging to see several old members roll up and take their place. This is as it should be, and for the effective working of the club, the individual co-operation of each and every member is essential. The prodigals were welcomed back to the fold in good old style, and although the fatted calf was not in evidence, the welcome was no less sincere.

The club's transmitter, which for some little time has been trying to emulate Rip Van Winkle, is now in a state of forceful activity, and for the past week has been giving a good account of itself. Any "ham" hearing the transmissions is requested to kindly QSL.

Owing to the late termination of business at the previous meeting the debate "P1 Circuit v. Three Coil" was inadvertently held over. This was held on another night, and quite a healthy discussion took place.

The exponents of the good old P1 were Messrs. Gray, Taylor, Smith and Barker; for the Three Coil Circuit, Messrs. C. Morton, Wetton, Stevenson, Fretten and Wilkins. Several points of capacity and inductance were raised and dealt with and a slight advantage gained by the 3 coil advocates. Discussions such as these bring forth much enlightening material for the true experimenter to ponder over, and the idea could be fostered with advantage to the club. The exponents of the two circuits are to be congratulated for the able manner in which they championed their respective fancies.

The "Reinartz" tuner was also discussed, one of our members having built the circuit during the week-end. Results to date have been excellent, and he has consented to bring it along one night for the benefit of the rest of the members. The writer had the pleasure of listening in one night recently, and was surprised at the tone and volume, it being quite audible 50 feet from the loud speaker, on a night that was not at all favorable for radio reception.

Two more members of the club are well on their way for qualifying for transmitting licenses, and should be proficient during the next month.

The meeting closed for transmission purposes at 10.20 p.m.

It is rumoured that our worthy Secretary has lost several front teeth. Taken in conjunction with the fact that a whistling solo was heard on Wednesday night last per medium of the ether, it is significant.

WOOLOOWIN RADIO CLUB, BRISBANE.

A further meeting of the above Club was held at the Club Room on Thursday, 21st instant. The attendance was again satisfactory. Messrs. Love and Grant, the delegates to the South Brisbane Radio Club in connection with the Proposed Inter-Club debate, reported that they had visited the latter Club at its last meeting and that arrangements for the debate had been satisfactorily finalised. The meeting of the Clubs will take place

(Continued on Page 33.)

A Few Hints on Learning the Morse Code

By Wireless Weekly.

NO doubt every reader of Wireless Weekly is in possession of a wireless receiver of some kind and it is more than likely that those receivers are not only able to pick up speech and music, but also wireless telegraphy signalling in Morse, which is constantly going on between ships and coastal stations and between long distance high power wireless stations.

You are interested in these signals for the simple reason that you do not understand them; when you do understand them you will be absolutely fascinated by reading them, and will probably be leaving the broadcast programme for a few minutes to see if Singapore is still working Bombay or vice versa.

These noises, as you will probably think they are at first, are really important wireless signals, being sent in the Morse code. They are a collection or series of dots and dashes in certain orders, and one has to be constantly practising if he or she wishes to understand how to interpret these dots and dashes. They are really short and long buzzes.

If you press your electric bell push for say two seconds, that would be a single dash in the Morse code. If, however, you just press the bell push, and let it go immediately the bell will only ring for a second, and that would correspond to a dot in the Morse code. A dot and a dash have no definite length. The dash should, however, be distinguishable from the dot by being twice the length of the dot. If you are sending quickly, naturally your dots and dashes will both be shorter. By combining these dots and dashes in 26 different orders, you can represent every letter of the alphabet.

Example.

The letter A is represented by one dot followed by one dash (.-). The letter B is sent by making one long dash followed by three dots (- . . .) and so on, each letter being distinguishable from the other by the number or arrangement of their dots and dashes.

When sending a complete word a larger space or pause should take place between each group of dots and dashes which form the separate letters. For Example, the word "dog." The first letter is made dash two dots (- . .), a small pause, then the letter 'o', which would be three dashes (- - -), now another pause, then the letter 'g', which is dash dash dot (- - .). If there is no distinct

pause between each letter, no intelligible meaning will be got from the collection of dots and dashes.

If you practice the Morse code regularly you will soon get into the habit of distinguishing individual letters by their collective sound, and instead of having to work out each time in dots and dashes and deciding what letter is meant, you will be able to write it down right away. A longer pause takes place between words than between individual letters, so that you will readily see when to start a new word.

It is the aim of Wireless Weekly to assist its readers and the experimental movement generally so that from the 2nd of June, we shall be commencing a series of Morse classes by radio from station 2WW, on a wavelength of 220 metres, and from that date on every Tuesday, Thursday, and Sunday from 7.30 p.m. till 8 p.m. these classes will continue. On Tuesday, the 2nd of June, the first six letters (A to F) will be taught and from then onward till the twenty-six letters have been taught, six letters will be taken each night, after which general Morse code practice will continue up to a speed of 12 words per minute.

Now in starting off on this code practice, we are filling a definite want, and carrying out a service that has never before been attempted seriously in Sydney. As we mentioned last week, the lessons will be given by experts whose Morse is irreproachable, and whose years of practical experience afloat and ashore render them particularly suited for the job.

We know that you readers who are interested will appreciate the fact that we are anxious to help you. You can amply repay us by letting us know whether we ARE helping you. It is quite possible that, in making preparations, we may have slipped on a few little points which may occur to you—if so please don't hesitate to write us—and if there are any little matters which we can't very well deal with over the air in the limited time at our disposal and upon which you may require advice, you have only to drop us a line and ask. And, as a final word, remember this—the learning of the code primarily requires the exercise of two things—patience and practise. At first you will find picking up the characters a trifle difficult—in fact, you will probably do a little quiet cussing—but, the moment you learn to recognise the general sound of each letter, not so much by the dots and dashes individually, but as one complete group, if you can understand our meaning, you will be surprised how

"What is a Double Seven?"

"The worlds best valve."

easy it is to know them immediately you hear them. The wavelength we have chosen is 220 metres, clear of both amateurs and broadcasting stations. On the first evening, Tuesday, June 2nd, at exactly 7.30 p.m., we shall commence sending a series of

good point to remember is this—write everything down that you hear, no matter if it is sent a dozen times over. This gets you used to communicating your impressions to paper and makes the path much easier. Keep your practice sheet, because later on when you are coying amateurs and high power stations, you can turn to them and wonder how you ever did it.

Here are the approximate sizes of coils you will require to pick up 2WW:

P1 Circuit,

With condenser in series, P35, R50. With .001 condenser in parallel, the same coils will be O.K., but a .0001 fixed condenser should be placed in series with the aerial.

Tuned Plate Circuit.

For the primary and reaction coils the same remarks as above will apply. Tuned plate coil 35.

3 Coil Circuit.

With aperiodic aerial tuning, P5, S35, R50. In this case it will be necessary to link the earth side of the secondary coil to the lower side of the aperiodic coil.

(Editor's Note.—Due to pressure of space, we were forced to hold over a further special article on the Morse code practice. It will be on time next week, however.)

Would readers kindly note that all communications intended for "Wireless Weekly" should be sent to 12/16 Regent Street, Sydney, and not to the Editor's private address? This will obviate any possible delay in replying to correspondence.

The International Code

See how quickly you can memorise this

A	. —
B	— . . .
C	— . — . .
D	— . .
E	.
F	. . — .
G	— — .
H
I	. .
J	. — — — —
K	— . —
L	. — . .
M	— —
N	— .
O	— — — —
P	. — — .
Q	— — . —
R	. — . .
S	. . .
T	—
U	. . —
V	. . . —
W	. — —
X	— . . —
Y	— . — —
Z	— — . .

FIGURES.

1	. — — — —
2	. . — — —
3	. . . — —
4 —
5
6	—
7	— — . . .
8	— — — . .
9	— — — — .
0	— — — — —

U. S. AMATEUR TESTS

The A.R.R.L. is planning to conduct some tests using wavelengths of 40, 20 and 5 metres, the probable dates being July 18-19, 25-26 and August 1-2, according to latest advices from headquarters. The A.R.R.L. wants co-operation from Australians and as we have been promised full particulars by a later mail, we expect to be able to publish full particulars in plenty of time.

By the way, we are informed that Mr. Schnell, who is making special tests on behalf of the A.R.R.L. with the American fleet is very probably on board the flagship, U.S.S. "Seattle."

FOR SALE, 3 Valve Set in Cabinet, P1 Circuit, Atlas loud speaker, batteries, coils, complete; cheap. MUST SELL. 36 Foveaux Street, City.

EXIT — Ordinary Valves

ENTER — Non-Microphonic Tubes

THE "WONDERFUL TRUE BLUES"

"What is a Double Seven?"

"The world's best value."

dots which will last for three minutes, so that you can get the proper tuning. When you have it correctly, make a note of the settings so that you can tune in without trouble on the next practise evening. After the dots, announcement will be made by 'phone and then practice will commence. A very

OUR "B" CLASS STATIONS

By F. BASIL COOKE, F.R.A.S.

(Director of Wireless, David Jones Ltd.)

NOW that the winter has commenced, the wireless set is receiving even more attention. As a means of entertainment it has no equal, and it is a hobby of the first water. For months now we have been considering 2FC and 2BL as the only Sydney stations on the air, while all the time excellent programmes have been given by two of our "B" stations.

Considering that these latter stations receive no subsidy from the broadcast license fees, it is very gratifying to see the enthusiasm taken by the owners of the "B" stations in giving a daily programme at their own expense. Speaking of the programme, it so happens that every now and then something particularly choice is given, rivalling, indeed, the more powerful "A" stations.

Mr. O. Sandel is particularly enterprising in this regard. He is the owner-operator of 2UW, and for many months past his station has been heard far and near. It is well worth while every now and then to listen-in to this station, as his transmission is perfect. Next Friday, May 29th, 2UW will be giving a particularly interesting programme.



Mr. O. Sandel, before the transmitter.

From 2FC we have heard a few candidates for the forthcoming elections giving their views. Mr. Sandel is going to give us the opportunity of hearing a number of them in one evening, together with a particularly interesting musical programme. This is the first time that the Australian public will be given the chance of becoming familiar with their probable candidate under such pleasant conditions. Mr. Sandel has gone to considerable trouble to arrange these programmes, and in the opinion of the writer the experiment promises to be of particular interest. Mr. Sandel has kindly supplied me with the following programme:—

THE SPECIAL PROGRAMME FROM 2UW ON FRIDAY, MAY 29

8.0—Miss Ada Althouse (piano).

Miss Doreen Douglas (violin):

Henry VIII. Dances.

8.5—Miss Jean Kennelly (soprano):

(a) Love's Cigarette.

(Continued on Page 16)

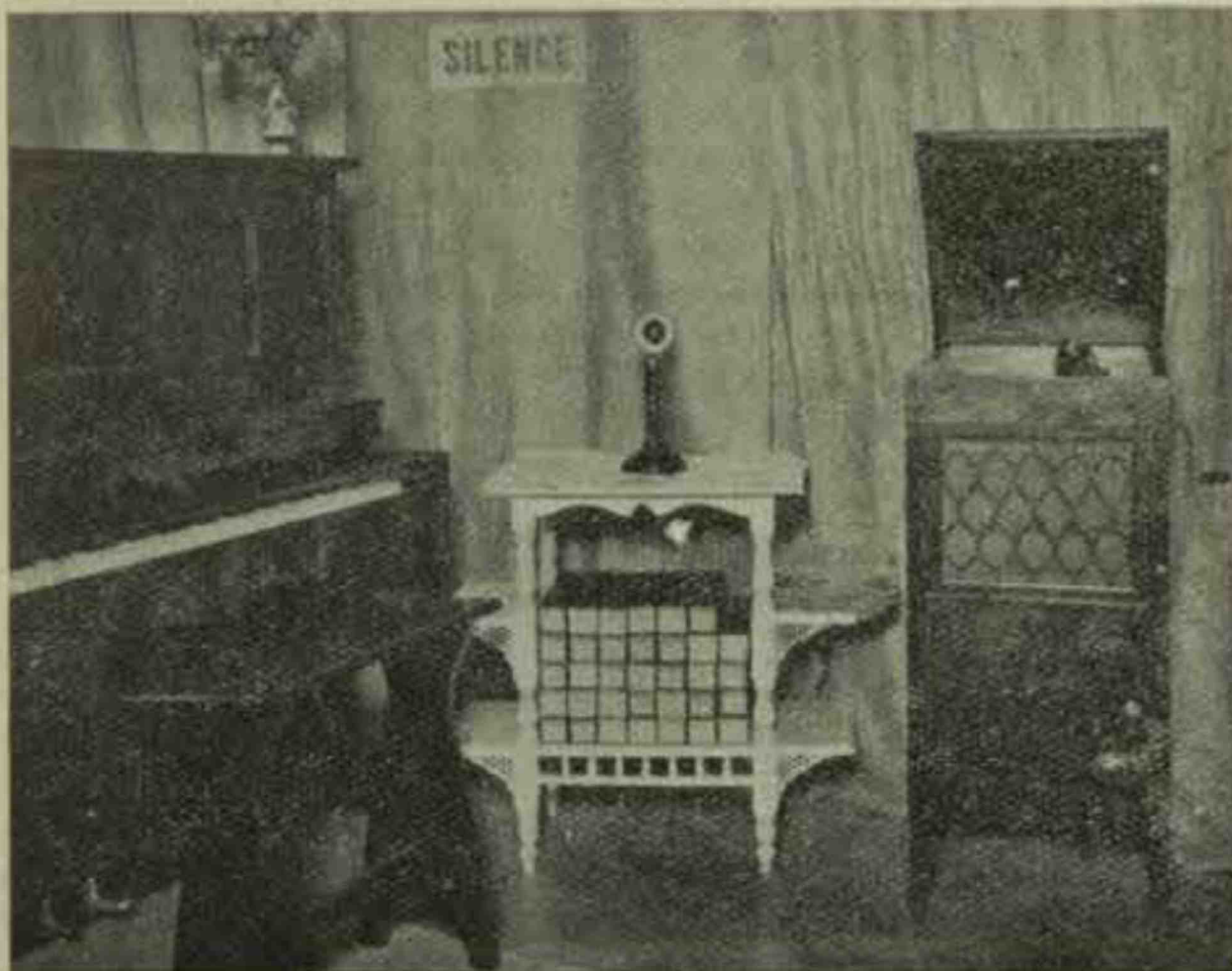

Interior View of 2UW.

The Essarr Two Valver

By *INSULATOR*

IT is pleasing, indeed, for me to complete a receiver and find it comes right up to my expectations. Without egotism, I may say that there are few men who have the experience of so many and varied types of receiving sets as myself.

Not every one I build finds its way into the columns of "Wireless Weekly." Before I publish the description of any receiver it must have some merits—there must be something to recommend it. In this week's set will be found quite a lot of points to recommend it. It boasts of a, or I might say two, particularly popular circuits, the P1, and also the three coil circuit. The three coil circuit is popular on account of its selective properties; local interference, if not quite eliminated by its use, is greatly minimised. Actually, the first station I heard on this little outfit was 3LO, Melbourne. It happened that when I first "baptised" it with valves, batteries, aerial, etc., 2FC was indulging in a "just a moment, please" interval, and the carrier wave I converted told me in the usual hasty manner that it was "3LO, Melbourne." Then in came Farmer's with a rebounding crash to drown out Melbourne, but careful manipulation brought back 3LO, and I am sure had I wished I could have held this station all night.

This satisfied me on the value of the three coil circuit on the point of selectivity. To-night again 4CU (whoever that is) came along nicely and sweetly during 2BL's transmission, as did 3AR and 5CL. This achievement I am very proud of when I take into consideration the tame affair to which I give the name aerial. So much for the three coil portion.

The P1 (two coil) is a very old favourite of mine. For local reception it is very hard to beat, and those of you who build this set will be able to prove it. On looking at the circuit it will be found

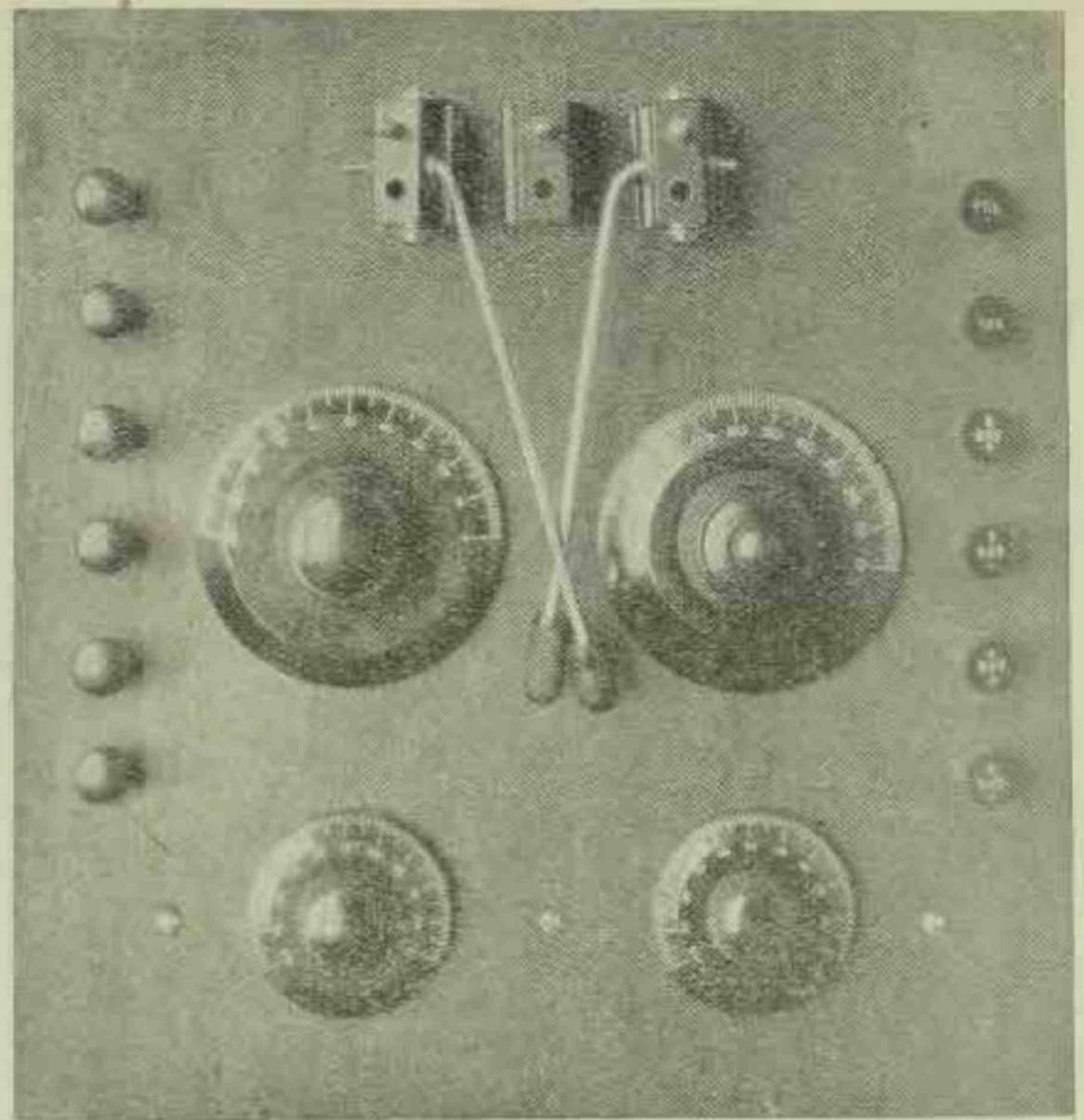

Front Panel View.

that there are four aerial terminals and two marked earth. Let me explain these to you before I go any farther.

A1, A2, and E1 govern the primary circuit of the three coil receiver. Should the aerial condenser be desired in series (which is always best for short wave work), the aerial is connected to A2 and earth to E1, leaving A1 free. On the other hand, parallel arrangement is obtained by linking the aerial to A1 and earth E1, but MARK THIS: join A2 to E1 by shorting these terminals with a short link made from bus bar. This link can conveniently be left permanently connected to A2 and opened or closed as desired. This arrangement is better than all series parallel switches, certainly much more efficient. But, oh! people, don't forget the linking arrangement. It must be borne in mind that series parallel is only affected when the three coil circuit is used.

The P1 or two coil circuit lends itself to two methods of aerial connection—firstly, constant aerial tuning by connecting the aerial to A3, and, secondly, straight-out parallel tuning by hooking up to A4 the earth were in each instance being connected to E2. Again, for the standard type of untuned primary, low loss circuit, the aerial may be connected to A1 and earth wire to E1, which is now connected

"New System"—the Trade House for all Wireless requirements..

to E2. Certainly these six terminals lend themselves to a most elastic method. Mr. M. A. Hopkins once showed me an arrangement he had devised which would give a greater choice of aerial-earth connections by the use of seven terminals. Perhaps he will submit his scheme to the readers of our worthy journal.

The following list of materials went into the making of this week's receiver. Where I have specified the brand of an article it is not intended to bind readers to this particular make, but merely as a guidance:—

- 1 Bakelite or Radion panel, 11 x 10½ x 3/16.
- 3 De Luxe panel plugs (2 movable and 1 fixed).
- 2 .0005 Variable condenser, 1 vernier.
- 2 Rheostats.
- 2 Valve sockets.
- 1 Crossley 9 to 1 transformer.
- 1 .0001 Fixed condenser.
- 1 .002 Fixed condenser.
- 1 .00025 Fixed condenser and clips.
- 1 Grid leak (say 2 meg.).
- 6 Plain ebonite terminals.
- 6 Engraved ebonite terminals.
- 6 Bus bars, sundry screws, etc.
- 1 Baseboard, 10 x 6 x ½.

A glance at the illustrations will show you the arrangement of these parts, and I don't think this little two valver looks too bad. Actually I think it looks rather well. Come with me to the back of panel now. With the exception of one rheostat all the parts will be easily seen. Suspended in mid-air underneath the A.T.C. is the grid leak and condenser. This ensures a short grid lead. However, more about that later. This week a panel layout is given. Like old times again, isn't it? So I advise you to follow this layout. Of course, only the centre spindle holes of the variable condensers

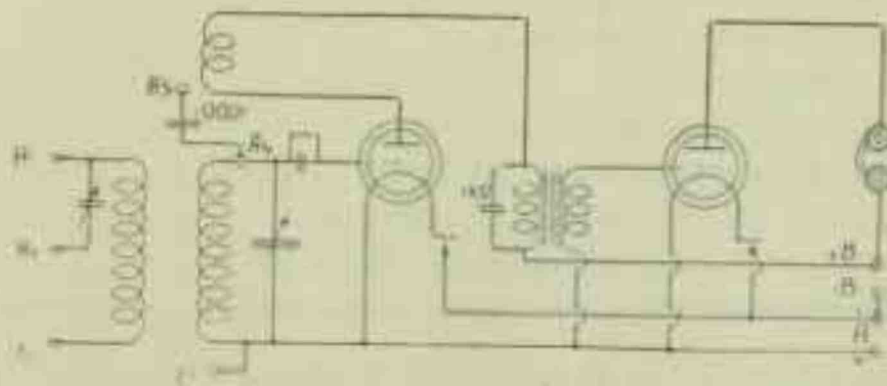

are given; the template usually supplied is of much assistance to you.

Go ahead now and mark off the panel as shown.

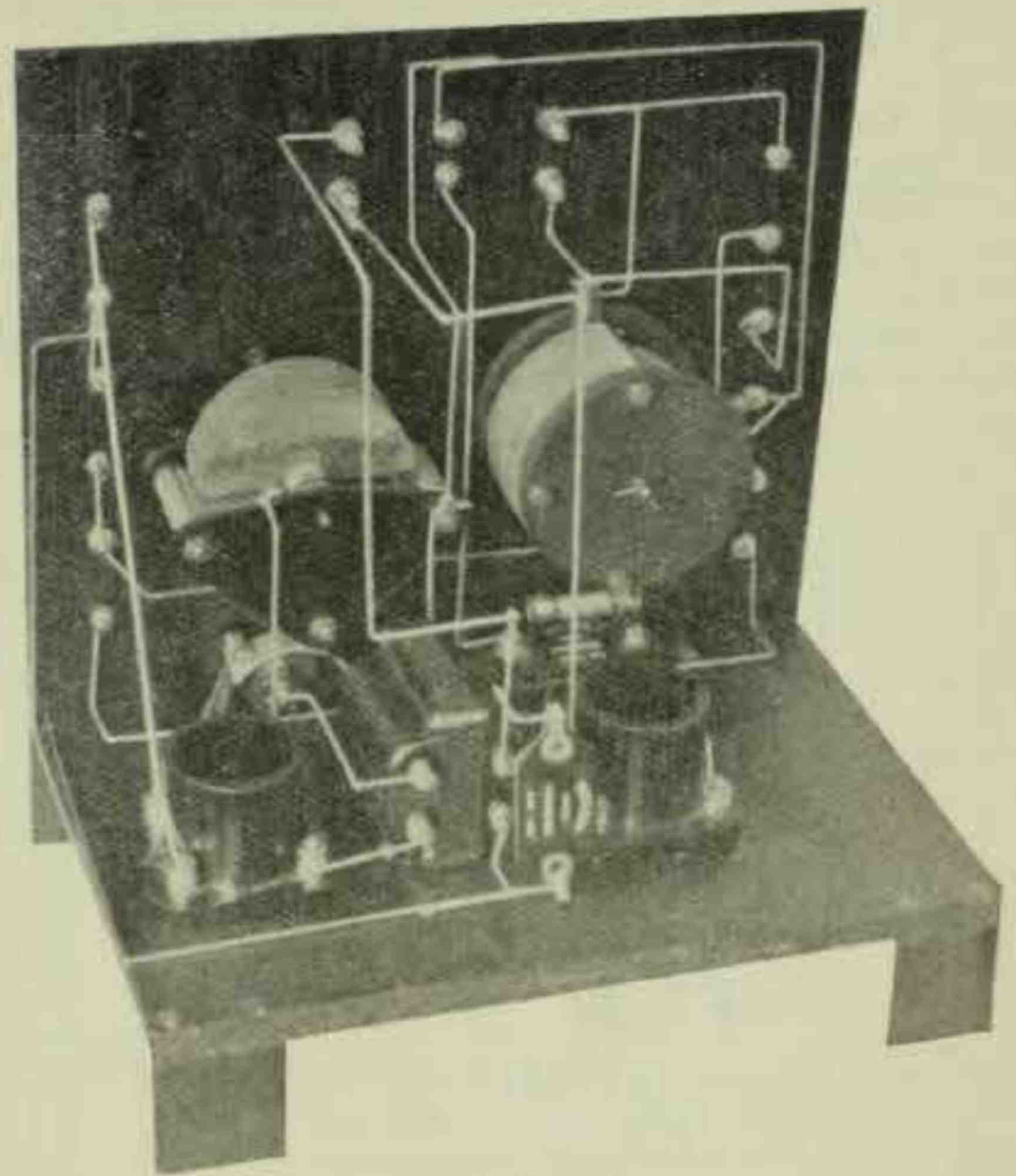

The Back Panel.

Centre punch before drilling to prevent the "gaby glide" which all good drills like to do on a perfectly polished panel. Having drilled, set to and mount the terminals, rheostats, coil holder, and condenser. Leave this down while you fix up the baseboard. Blacken it, of course, or shellac it if you prefer.

Do you notice in the back of panel view how only half of the rheostats are shown? The other half is below the baseboard. Hence it is necessary to cut out two portions of this board to give clearance to these rheostats. I don't need to enlarge any further on the layout of this baseboard. Consult the illustration for all further particulars, and layout as I have done. Now screw your baseboard to the panel. The holes for these have already been drilled in the panel. Yes, those are they on each side of the rheostats. Wire up now. Start with the bus bar, which goes from A minus to E2. Next connect up your negative terminal of each valve socket. Follow the wiring diagram closely and compare with the circuit diagram as you go along, and you will thus be able to reconcile things as you go along. Personally, I like wiring. Were you liv-

ing next door to me you would always know when I had reached the wiring of any receiver. I start whistling away and continue until the job is finished. You would also learn if the set didn't function when first tried. My voice is raised to the heavens disclaiming wireless and everything connected with it. But, oh! the song when it does go, particularly if it perks like this little fellow did on the loud speaker. And only two valves, mind you.

The wiring being completed, hook up your

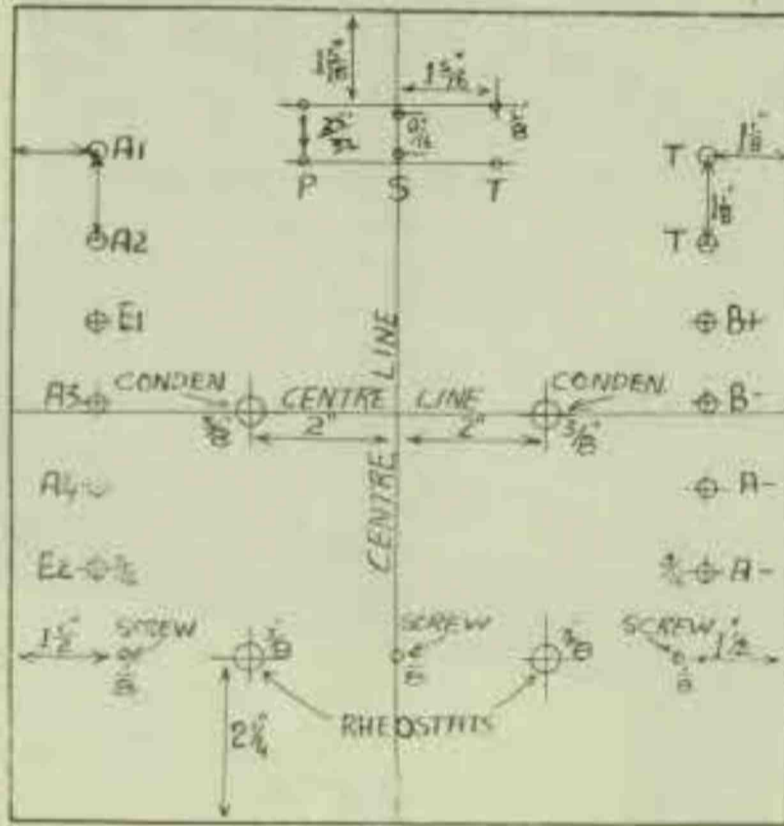

PANEL LAY OUT

aerial, earth, batteries, etc., to their respective terminals. Insert your honeycomb coils, light up your valves, and listen in. Twiddle your condensers, and, oh! boy! Isn't it good? Alter the coupling of your coils until loudest signals are obtained. Play about with it a bit, and you will quickly understand it. It's a splendid little set, isn't it? The coil list given here is only approximate, of course:—

STATION.	P	S	T
2UW	25	35	50
2UE	"	"	"
2BL	35	35	50 or 75
2FC	200	200	200 or 150
3LO	"	"	"
6WF	"	"	"

The latter station I picked up since starting to write this article. Amateurs also can be logged by

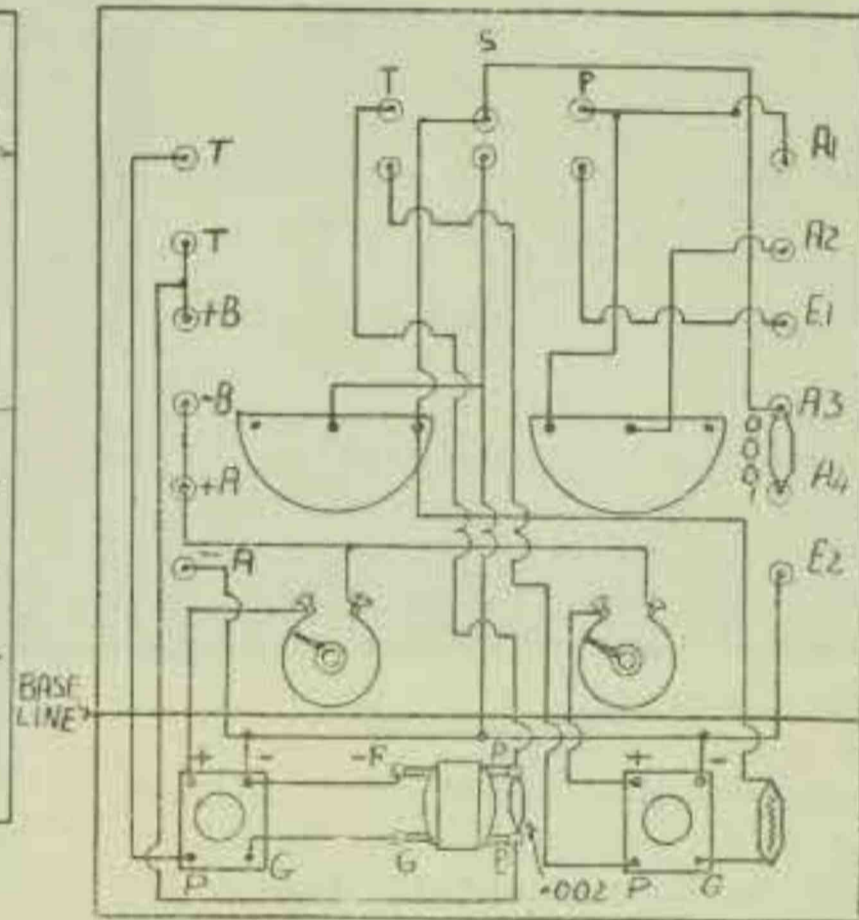

the use of spider web coils. I think I used 3, 12 and 12 turns for primary, secondary, and tickler.

Still, these coils are easily wound, and you can experiment a bit to see which gives the best results. An all-round receiver, isn't it? Make it up; you'll be glad, considering two valves give nice loud speaker strength. Sufficient to entertain yourself and all the family—and sweet, too.

(Continued from Page 13)

- (b) Mexicali Rose.
- 8.15—Speech.
- 8.25—Miss Doreen Douglas (violin):
 - (a) Souvenir.
 - (b) Humouresque.
- 8.35—Mr. George Dalton:
 - Sweet Hawaiian Girl of Mine.
- 8.40—Speech.
- 8.50—Miss Ada Althouse (soprano):
 - (a) A Field of Daisies.
 - (b) Sing, Joyous Bird.

- 9.0—Mr. Harper (tenor):
 - (a) The Pal That I Loved.
 - (b) Dreamy Melody.
- 9.10—Speech.
- 9.20—Mr. Manuel.
 - (a) Una furtiva lagrima (by Donizetti).
 - (b) A Spirit Flower (by Tiptan).

(Continued on Page 34.)

FOR SALE: One valve set in cabinet, with phones, valve, batteries, and aerial wire complete. Sacrifice—£5/15/-. A.B., C/o Wireless Weekly.

EXIT — Ordinary Valves
ENTER — Non-Microphonic Tubes

THE "WONDERFUL TRUE BLUES"

AERIAL COUPLINGS

By E. G. BEARD.*

THE recent recruit to the ranks of amateur wireless experimenters is often puzzled by the numerous methods of coupling the aerial which picks up the signals to the tuning arrangements which apply these signals to the detecting device. Every week circuit diagrams are published which only differ in this respect, and the object of the following brief notes is to explain the how and why of these methods, and to show that there is no real fundamental difference between any of them. Some are more convenient than others, but none, when properly adjusted, are better than the others.

Wireless is really no more mysterious than ordinary alternating current electrical engineering; the same rules apply and similar actions take place. The main difference between a wireless receiver and an alternating current power system is in the form of generator used. In power systems the energy is generated by the motion of a wire in a magnetic field. In wireless receivers the energy is generated by the motion of some type of electro-magnetic wave with respect to a wire called the aerial.

Two very sound maxims apply to both cases. It is impossible to take more energy out of a generator than is put into it. If a five horse-power motor is driving a dynamo, it is impossible to get more than five horse-power of electrical energy out of the dynamo. Similarly we cannot get more energy out of a simple receiver than the aerial puts into it, and the aerial cannot put more energy into the receiver than it picks up from the wireless wave. That is the first important point to remember.

The second one is not quite so simple. It is that there is a certain arrangement of resistance losses in the internal and external circuits of a power supply circuit which is most efficient; and, further, that this arrangement is such that the resistance losses inside the generator are equal to those in the outside circuit. This statement being expressed in terms of a wireless receiver is as follows:—

The most efficient use of the energy picked up by an aerial takes place when the circuit arrangements are such that the resistance losses in the aerial circuit are equal to the resistance losses in the receiver.

Figure 1 shows an example which explains these statements so far as a power supply circuit is concerned.

In this circuit imagine that the resistance of

the secondary is one ohm and that of the primary 100 ohms. Further, that we have a current in the primary of one ampere, and wish to get the maximum current in the secondary with minimum power supply.

The watts lost in the primary will be

$$1 \times 1 \times 100 = 100 \text{ watts.}$$

If the transformer steps the current up 10 to 1, the watts lost in the secondary will be $10 \times 10 \times 1 = 100$ watts, and the total power required $100 + 100 = 200$ watts.

If the transformer steps up the current 100 to 1 the secondary current will be 100 amps, and the losses $100 \times 100 \times 1 = 10,000$ watts, i.e., total power 10,100 watts.

For a third case, if the transformer steps down 10 to 1 the secondary current will be 1/10 ampere

$$1 \quad 1 \quad 1$$

and the watts lost $\frac{1}{10} \times \frac{1}{10} \times 1 = \frac{1}{100}$, i.e., total

power 100.0 watts. The efficiency of these three cases is the ratio of power input to secondary current as shown below:

$$\text{Case 1. } 200 \text{ to } 10 = .05.$$

$$\text{Case 2. } 10100 \text{ to } 100 = .001 \text{ (app.)}$$

$$\text{Case 3. } 100.01 \text{ to } .1 = .001 \text{ (app.)}$$

It is self-evident that the efficiency is greatest in the first case, i.e., when the current losses in the primary equal the current losses in the secondary. It is further obvious that this condition can be reached by using a transformer current ratio of suitable size.

In the case of a wireless circuit the primary represents the aerial current with its resistance and the secondary the tuned circuits of the receiver. The transformer is the coupling of the receiver to the aerial.

Many amateurs work on the basic principle that maximum voltage is required at the detector, and therefore a step up transformer is desirable. So it would be if it were not for the fact that tuned circuits are used, and the voltage actually applied to the detector is really the back voltage across a coil or condenser, and this increases with an increase of current. Another factor also has to be considered. The aerial can only supply a limited amount of power. It is quite plain that the less the power wasted in resistance losses the more will be available for the detector. In the case of audio frequency amplifying transformers the ratio of the

*Chief Engineer, United Distributors Ltd.

transformer should be designed to suit this balancing of resistance losses, and a step up is required, because the transformer is not tuned, but when tuned circuits are coupled together a step up of current instead of voltage is necessary to produce a large voltage across the inductance of the secondary circuit. That is, of course, provided that the secondary circuit has a lower resistance than that of the primary, which should be the case in practice.

By suitable design it is possible to reduce the resistance of a tuned circuit to a surprisingly low value, but the aerial resistance can never be less than a certain amount. Therefore, the secondary circuit should have a low resistance.

The aerial resistance may be divided into two portions. Firstly, the ohmic resistance, which can be reduced by suitable design; and, secondly, the radiation resistance. The radiation resistance of an aerial is the measure of the amount of energy it can pick up from a wireless wave, and, therefore, if it is reduced the power it can pick up will also be reduced.

It is difficult to measure the radiation resistance of an aerial, but it is quite easy to calculate it approximately. The formula is:

$$\text{Radiation Resistance} = 1600 \frac{(\text{Effective height of aerial in metres})^2}{(\text{Wavelength in metres})^2}$$

It should be noticed that as the height of the aerial is increased its radiation resistance is also increased, i.e., it will pick up more energy. Also as the wavelength to be received is increased the radiation resistance is decreased. That means that any aerial picks up more power on a short wavelength than on a long one.

From the formula the radiation resistance of an aerial of 10 metres effective height on a wavelength of 200 metres is 4 ohms; thus in such a case it is an absolute impossibility to reduce the resistance of the aerial circuit below this value. Thus it will be seen that the resistance of the secondary of a receiver should always be less than that of the aerial. Also it is evident that resistance in the aerial circuit is not nearly such a bad thing as resistance in the secondary circuit. If the resistance of a secondary circuit coupled to this typical aerial had a value of 1 ohm, it would be most efficient if it were so coupled to the aerial circuit that a current transformation ratio of two existed between the two. In other words, if one ampere of current were flowing in the aerial circuit, the coupling should be such that two amperes will flow in the secondary. Then the losses in both circuits would be equal, viz., four watts.

Thus we have the reason for the numerous so-called aperiodic aerial circuits which have become

so popular. They are of value because they act as current transformers, and can be designed so as to have the necessary current transformation ratio for maximum efficiency and minimum losses.

It is proposed to examine some of the simple circuits it is possible to use for this purpose, and give a simple explanation of their action. If the amateur public appear to desire it, perhaps at a later date it will be possible to give more complete explanations and simple formula which enable their action to be foretold in both transmitters and receivers.

Figure 2 shows a circuit and its theoretical equivalent (neglecting the inductance of the aerial) which was very popular with certain members of the Derby Wireless Club in 1912. Scott Taggart has also recently published it and talks of it as the "constant aerial tuning system," but few seem to realise its value as a current transformer. C_a represents the aerial capacity, C_1 is a small condenser in series with the aerial, R_a is the resistance of the aerial, L an inductance suitable for the wavelength, R_r is the resistance of the secondary, i.e., mainly that of L , and C_2 is the tuning condenser.

To explain its action, imagine the secondary circuit to be broken at X , and a voltage applied there similar to that produced by the wave it is desired to receive. A current will flow through the coil L and its resistance R_r , and will then divide, returning to the point X through the two paths C_1, R_a, C_a and C_2 . Notice that all the current passes through L and R_r , and only portion through C_1, R_a, C_a , and another portion through C_2 .

The ratio in which the current will divide between these two paths depends on the sizes of the respective capacities. If the capacities of the two paths are equal, half the current will flow through each. If the capacity of the path through C_2 be twice that of the other path, two-thirds of the current will flow through C_2 and only one-third through the path C_1, R_a , and C_a . Thus by altering the sizes of the capacities of these two paths the current through R_a may be made equal to any portion of the current through R_r . Thus the action, so far as the current through the two resistances is concerned, is that of a step down current transformer whose transformation depends on the sizes mainly of the two condensers C_1 and C_2 .

If now the voltage be applied as in a receiver, that is across R_a , the circuit will function the opposite way as a step up current transformer, and it is thus possible to obtain that much desired equality of resistance losses which results in minimum loss by altering the sizes of the condensers C_1 and C_2 . The smaller C_1 in comparison with C_2 , the larger the current transformation ratio.

Have your batteries recharged at the "New System" Service Station.

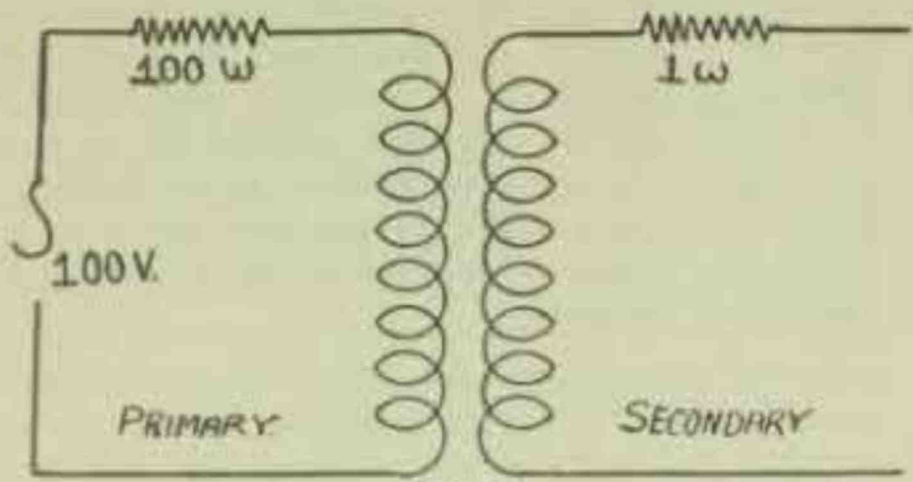

FIG 1

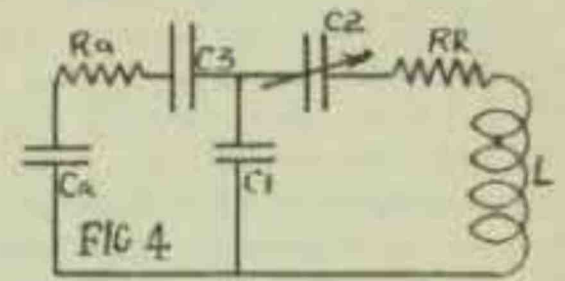
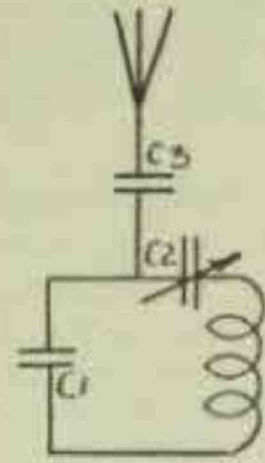

FIG 4

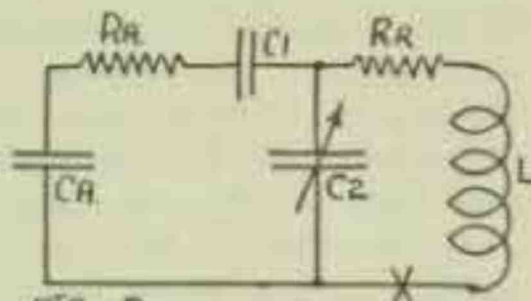
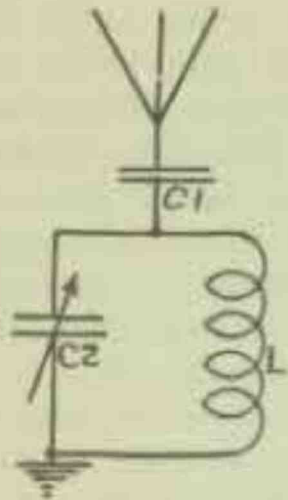

FIG 2.

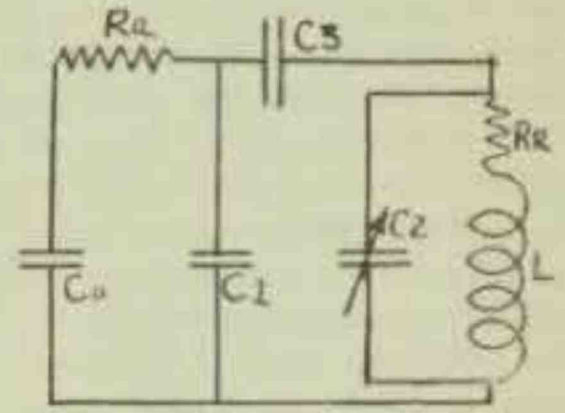
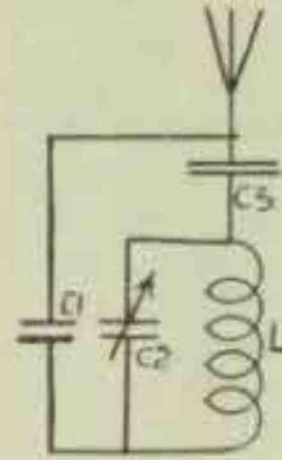

FIG 5

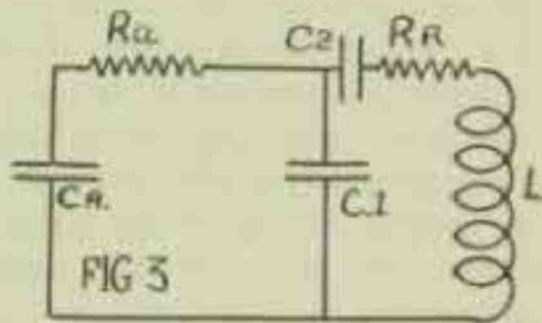
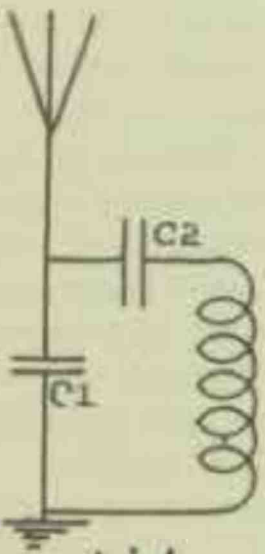

FIG 3

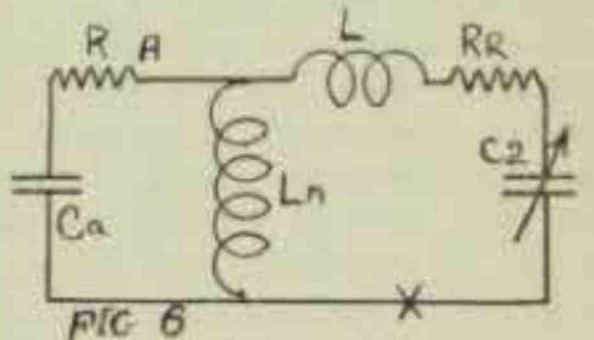
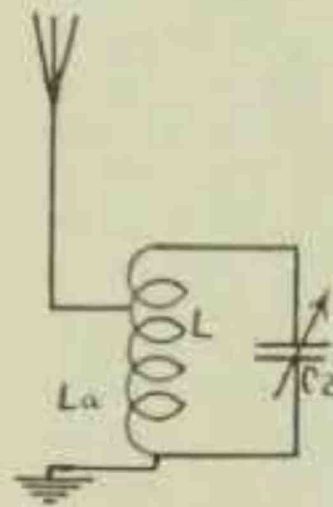

FIG 6

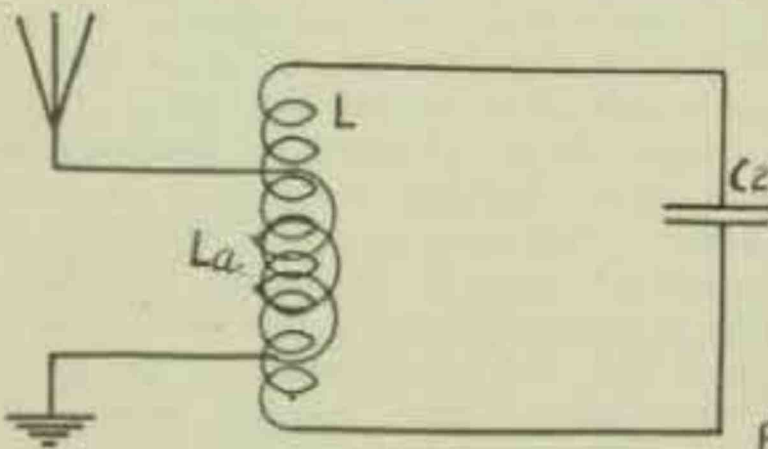
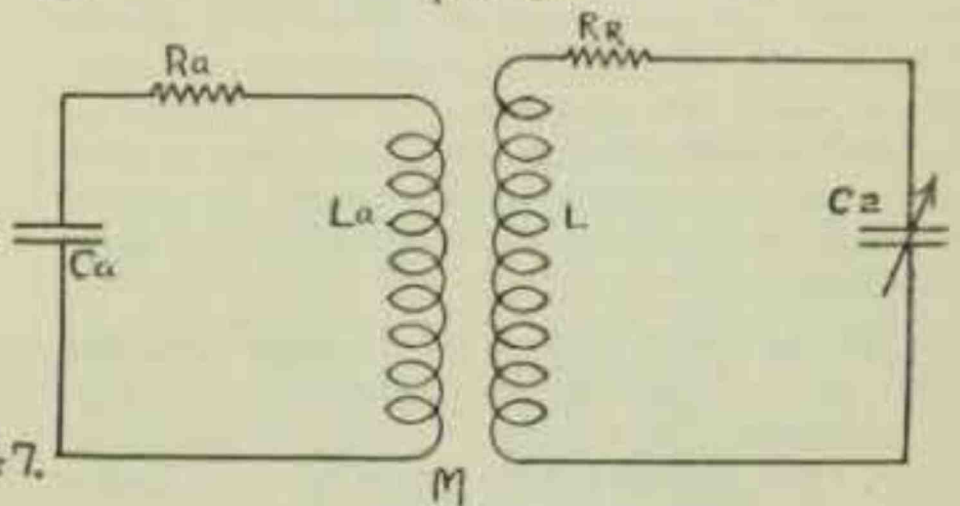

FIG 7.



M

In practice it is usual to make C1 a fixed condenser of about .00015 mfd. When this is done the circuit suffers from the disadvantage that as the tuning is done with C2, the current transformation ratio is decreased with a decrease of wavelength, whereas it should increase, because the radiation resistance of the aerial increases. This can be overcome by further reducing the value of the series con-

denser C1, but unfortunately so doing usually increases the losses in this condenser. It may be regarded as a general rule that decreasing the size of a condenser usually increases its resistance losses if continued beyond a certain point.

Figure 3 shows a much better circuit, which I have often used with great success, as in it the current transformation ratio is independent of the tun-

Ask your dealer to show you the Yaxley Stand.

ing and remains constant over the whole band of waves. Of course, that is not what is wanted, but it is better than increasing the ratio when increasing the wavelength.

In this circuit C1 controls the transformation ratio and C2 does the tuning. As before, the transformation ratio depends on the ratio of the path through C1 to that through Ca. However, Ca is large, and therefore C1 can also be large and efficient. Tuning with the condenser C2 does not affect this ratio, and therefore the current transformation ratio remains constant. The tuning adjustments do not vary much with different aeriels. If C1 is made adjustable the ratio can be varied within fairly wide limits without affecting the tuning, and it is possible to obtain the desired ratio quite easily when tuning-in. Perhaps the most serious disadvantages of this system are two. The coil L has to be larger than in the first method, and therefore its resistance may be larger; and, again, the condenser C1 may have to be much larger on very short waves than the actual capacity of the aerial. This last defect can be easily overcome, as in Figure 5, by introducing a small or comparatively small condenser, C3, in series with the aerial. This is really a combination of the circuit in Fig. 2 with that of Fig. 3, and is an arrangement which I have found to be of great utility. The only serious drawback to this method is the fact that the condenser C2 which is used for tuning has to be fairly large to cover a fair wavelength band, and the total tuning capacity is restricted to that of C2 in series, with C3 and C1 in parallel. However, using a condenser of between .00025 and .0005 at C3 and one of between .00015 and .001 at C1 (adjustable for varying coupling or ratio), a .001 variable condenser at C2 will usually cover about the same band of waves as a similar coil to L will with a .0005 condenser in parallel. Figure 5 shows the arrangement I have adopted as being most suitable for general use, using a .0005 condenser as the tuning unit. Condensers C3 and C1 should also be adjustable for suitable current transformation ratios.

In all the above circuits the condensers C1 and C3 need not be variable vacuum condensers. The simplest arrangement is a series of fixed condensers of suitable values arranged with two switches to enable suitable ones to be easily selected. It is worthy of note that in the arrangements shown in Figures 3 and 5 any capacity between the lead-in wire and the earth lead is merely in parallel with the condenser C1, and therefore such circuits are very suitable for installations where the set is placed a long distance from the spot where the aerial enters the building.

All the above types of couplings to the aerial may be classed under the heading of direct electric

or static current transformers. Next we have to consider a type of coupling which is popular with certain manufacturers in America, and which may be termed direct inductive current transformers. Their action is somewhat difficult to understand, but as they are very simple to construct are well worth attention. Figure 6 illustrates the circuit and its theoretical diagram.

The tuning condenser C2 is connected directly across the coil L, which is chosen to suit the wavelength. The earth is connected to one end of this coil, and the aerial connected to it so as to include a portion, Lm, of its inductance in the aerial circuit to earth. Ra represents the resistance of the aerial and Rr of the tuning coil. Let us treat this circuit as before. Suppose the tuned circuit be broken at X and a generator be connected there of the correct wavelength. The current will flow through C2, through part of L, and will then divide, portion passing through Lm and portion through Ra and Ca. The ratio in which the current divides will be governed by the reaction or impedance of these two paths. If Lm offers the least impedance, the majority of the current will flow through it. Incidentally, if both offer the same impedance a most interesting condition arises, which would require several pages to fully describe. However, it will be seen that it is possible to control this division of current by altering the value of Lm, i.e., by moving the aerial tap on the coil L. Now, if this voltage were applied across the resistance Ra, as actually happens when using an aerial, a similar distribution of current will take place, and thus the current through the circuit L and C2 will be much larger than that through the aerial circuit. Exactly why this happens would also take too much space to explain at present, but such action is part of the properties of resonant circuits, and may be explained at a later date. Unfortunately this method also suffers from a disadvantage. As the wavelength decreases the impedance of Lm increases and that of Ca decreases, and therefore the transformation ratio becomes smaller instead of larger, as is desired. The opposite happens as the wavelength is increased. Also on a large aerial with the same position of the aerial tap the transformation ratio becomes smaller instead of larger. This may be overcome by making the tap adjustable, but doing so usually increases the resistance of the coil if done by a switch, as it increases the dielectric losses. However, it is a very simple plan, and can be thoroughly recommended. It has the big advantage of enabling the tuning to be done by a condenser of similar capacity to that which would be required if the circuit were absolutely independent of the aerial.

Figure 7 shows a similar arrangement, in which

The attractive dealer's proposition—see "New System."

a few turns of wire in series with the aerial are merely wrapped around the main inductance L . L_a represents these turns— R_a the aerial resistance, R_r the tuned circuit resistance, and C_2 the tuning condenser. This circuit is really the same as the previous one except for the fact that there is no actual connection between the aerial and the tuned circuit. There is a connection, however, but it takes the form of the mutual inductance between the two circuits. This means that magnetic lines of force from one coil cut the other, and vice versa. Thus the action is just the same as though the two were common. In this form it suffers from the same disadvantages as the previous type in that decrease of wavelength decreases the transformation ratio instead of increasing it, but this can be easily overcome without introducing losses by arranging to vary the mutual inductance between the two coils by varying their positions with regard to each other. If the coil L_a can be rotated or moved away from the coil L , it is a most efficient arrangement under all conditions. However, to cover a wide band of wavelengths its size would have to be altered when coil L is altered, and this may introduce losses of the end turn nature, and in any case a moving coil, especially with taps, is very inconvenient.

All of the above types of coupling or current transformers are often known as aperiodic aerial systems. Such a name is really wrong, because the aerial is actually tuned. The whole circuits are complex tuned circuits, with two or more parallel branches, and the whole is brought into resonance with the desired wavelength by tuning one branch. Incidentally, they are resonant to two independent waves instead of one only.

Another extremely efficient type of current transformer or coupling tunes the aerial separately, but this system deserves special treatment. It is probably the most efficient of all, but has fallen into disfavour, due to the extra tuning dial involved.

Another interesting fact which follows from the previous notes is that the ohmic resistance of the aerial is of little importance in comparison with that of the coils used. If the coils have a higher resistance than the aerial, the adoption of any of the above systems will weaken signals instead of strengthen them. Also if the coils have a high resistance, lowering the resistance of the aerial system will have no appreciable effect on the signal strength. I wonder how many amateurs have improved their earth connection and soldered all joints, and then been surprised to find no improvement. I have met many who say it does not matter, because they tried it and got no improvement. The reason lies in the fact that the resistance of their coils was already higher than that of the aerial. Therefore,

before wasting money on reducing the losses in his aerial, the wise man will devote the energy and money available to the lowering of the resistance of the coils he uses. Those two words, "efficient coils," should haunt the amateur, and if inefficient coils are being used it is pure waste of money to purchase efficient low loss condensers and reduce the losses of the aerial system.

In addition to these current transformer systems increasing the strength of the signals it is desired to receive, they form about the most efficient interference preventers known. The larger the current transformation ratio the less interference will be experienced. Most of my experiments are conducted within quarter of a mile of 2FC, but the occasions on which it is impossible to get 3LO through on the loud speaker without interference are few and far between, while without them 3LO is not nearly so strong and cannot be heard at all through 2FC. However, for this purpose certain of the systems are more suitable than others according to whether the interfering station is on a longer or lower wavelength than the one on which it is desired to receive. It will be worth while for the owner of a set using an ordinary series or parallel condenser for tuning to try the addition of a few fixed condensers, both in series and in parallel, with the aerial, and a little perseverance should result in freedom from interference and considerably improved reception on the lower wavelengths. With a wavelength of 60 metres odd and a series condenser, placing a condenser of between .001 and .002 across the aerial and earth terminals has quite surprising results. The condenser, of course, must be an efficient one of either air or mica, with good connections to the foil used in its construction.

TRANSATLANTIC TESTS.

CLEAR two-way speech with the United States has taken place during recent radio telephony experiments at the Post Office 200 Kilowatt plant at Rugby. In the opinion of Post Office engineers, say the Daily Mail, within a year London subscribers will be able to speak to New York. Procedure in Transatlantic conversations will be the same as for a trunk call. When the number has been given, the subscriber will hang up his receiver, and when a clear line through from New York exchange to the American subscriber has been established he will be called and will then be in direct communication. The apparatus has been made by the Western Electric Co. Ltd., and will be tested by the company for several months before it is handed over to the P.O. authorities.

"True music" minor speakers, thirty-six and six.

The Amateurs' Proficiency Certificate

(Continued.) By "WIRELESS WEEKLY."

The Transformer.

FROM time to time various articles on transformers have appeared in "Wireless Weekly," but in order to make this series complete it is necessary for us to again briefly describe the action and construction of the transformer.

Probably one of the most important advantages of alternating currents over direct currents is the extreme ease with which the transformation from a low to a high voltage or vice versa may be obtained. Such transformations are effected by means of transformers whose efficiency exceeds that of any other known electrical apparatus. It consists of an iron core made of thin sheets of laminations of stallo iron, each sheet being japanned, oxidised or shellaced. Two or more coils may be so arranged that an induced current may be set up in the secondary at either higher or lower voltage than that of primary circuit.

If A.C. is supplied to the primary circuit and the secondary terminals are left disconnected (see Fig. 1), then an alternating current will pass through the primary winding and an alternating flux will be set up in the core. As the value of the alternating current is continually changing, so will the intensity of the magnetic field change. (See back article on alternating current.)

It will be seen that there are four variations in the number of lines of force passing through the coils during one cycle of current. A gradual increase in one direction, a decrease in the same direction, an increase in the opposite direction, and a decrease in the same direction as the last increase.

If there are more turns in the secondary winding than in the primary, the secondary voltage will be higher, and the transformer is then called a step-up transformer. If the secondary has less turns than the primary, the secondary voltage will be lower and the transformer is called a step-down transformer. In a well-designed transformer, practically all the flux due to the current flowing through the primary will cut every turn of the secondary winding also. From this it follows that the E.M.F. in each turn of the secondary is equal to that induced in each turn of the primary, so that the ratio of the total primary to the total secondary E.M.F. is simply equal to the ratio of the number of primary turns to the number of secondary turns. (See Fig. 2.)

For experimental wireless purposes we use both

step-up and step-down transformers. It is unnecessary to have two separate transformers where both high and low tension voltage is required as long as the high and low tension coils are well insulated by some good insulating material. To find the number of turns for any given secondary voltage, the number of turns per volt must be obtained from the primary side. Fig. 2 shows that we are using 1,000 turns in the primary, so that if we divide this by the voltage, 240, we shall have the number of turns per volt.

$$\text{Primary} = \frac{1000}{240} = \text{approximately } 4.5 \text{ turns.}$$

Now, if we wish to supply voltage for filament of a 5 watt tube we must make the step-down voltage 8 or 10 volts. Then with a suitable rheostat it is controlled at its proper rating. To find the number of turns necessary for 10 volts we multiply the turns per volt primary by ten:

$$= 4.5 \times 10 = 45 \text{ turns.}$$

In the same manner, if we wish to obtain 500 volts either side of a centre tap or 1000 volts right across the secondary, we multiply 4.5 by 1000:

$$= 4.5 \times 1000 = 4500 \text{ turns;}$$

taking a tap, of course, in the centre, viz., at the 2750 turn. This provides the centre tap.

We hope we have made this clear; so much can be said about transformers. Those who are in doubt are requested to write us, and our Technical Department will answer their questions regarding these articles, free of charge. The constructional data for building a suitable transformer for experimental transmitting purposes was dealt with a few weeks ago, so that it will not be dealt with here again.

Losses Found in Transformers.

Copper losses may be minimised by using the largest possible section wire for both primary and secondary wire.

Core Losses.

Two sources of loss occur in the iron core, namely, eddy current losses and hysteresis losses. If the core were solid throughout, large circulating currents would be set up in it in the same plane as the direction of the windings. These currents are termed eddy currents. They represent an expenditure of energy which would heat up the core unduly and damage the insulation of the winding. These eddy currents, however, are greatly reduced by laminating the core, viz., making them up of a number of thin sheets

If it's a "New System" product it's good.

of iron laid together and insulated from each other by a thin layer of shellac. In this manner the eddy currents are forced to travel in very narrow high resistance paths, and are kept down to such a small value that their effect is in no way serious.

Hysteresis Losses.

All iron has a certain tendency, when once mag-

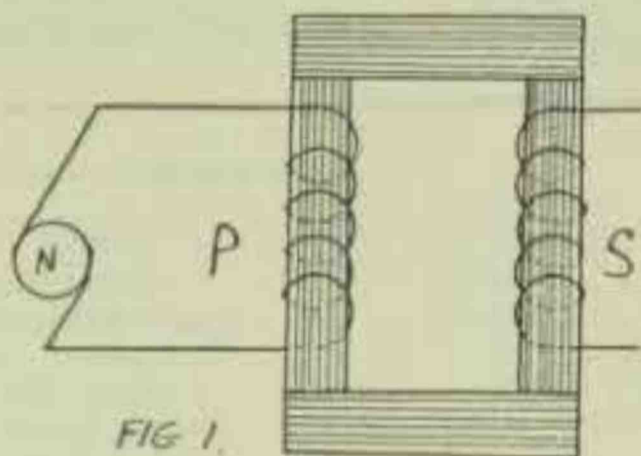

FIG 1.

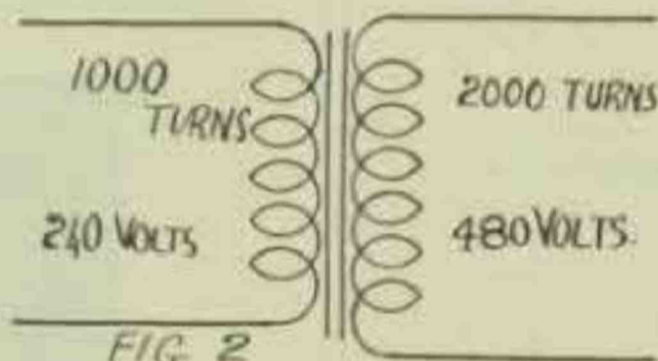

FIG 2

netised, to retain that magnetism, and it requires a definite expenditure of energy on the part of the alternating current to reverse this magnetism. There is, therefore, a definite loss in the core for this reason, it is termed hysteresis loss and appears in the form of heat. The higher the frequency of the alternating current and the more dense the lines of force in the core, the greater this loss will be. The soft Swedish stalloy iron has the least tendency to become permanently magnetised, and for that reason has less hysteresis loss than hard steel, which will not lose its magnetism quickly.

Efficiency of Transformers.

In a well-designed transformer of fairly large wattage, the expenditure of energy which must overcome these losses is not very great. In all commercial transformers with power from 1 k.w. upwards the efficiency is usually between 94 per cent. and 97 per cent. In the smaller transformer, however, the percentage of efficiency falls off rather rapidly on account of the smaller gauge wire used, etc. This is probably an advantage to the average experimenter, because if the efficiency is not too high and an accidental short takes place (which does happen very often) in connecting up for transmitting, the windings will probably stand up to the strain.

The Auto Transformer.

This is a special type of transformer used for small step-up or step-down voltage.

Figs. 3 and 4 show a step-up and step-down auto transformer.

In Fig. 3, the flux due to the primary current will thread the whole coil, and consequently the D.P. between the secondary terminals will be greater than

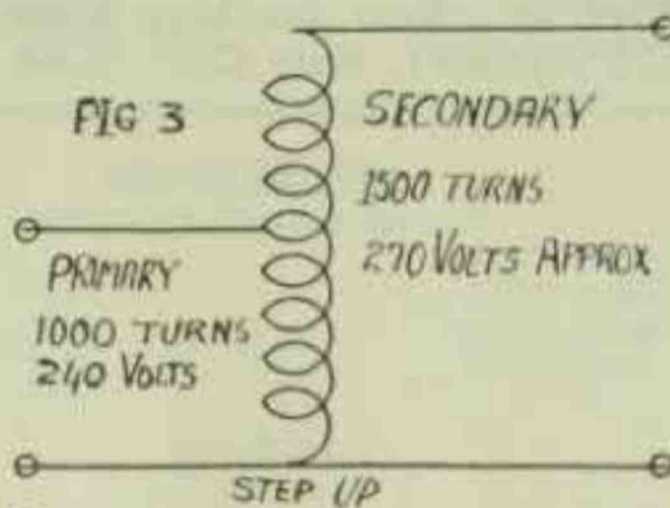

that applied to primary terminals, proportional to the number of turns added after the primary tapping. The A.C. flowing in the primary will be greater than the secondary current in the same proportion.

Fig. 4 shows the step-down transformer. An auto transformer is unsuitable for a big step-up in

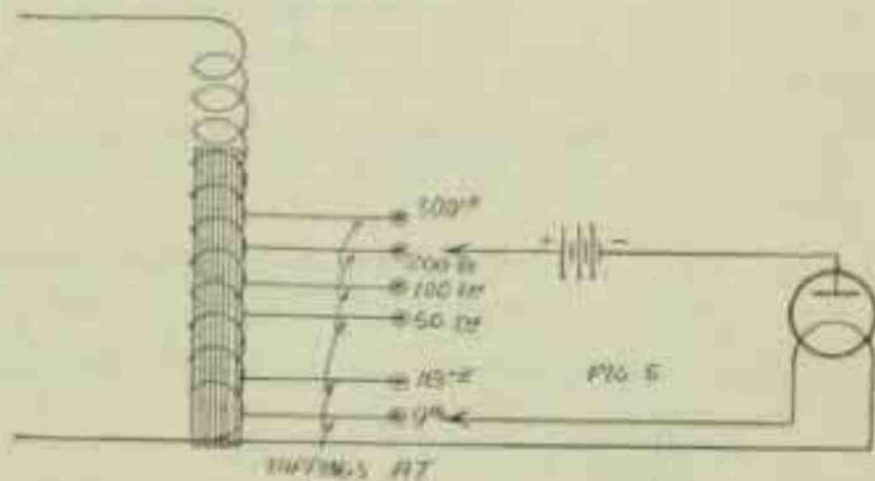

Primary. A.C., 1000 turns, 16 or 18 D.C.C., on 1 1/2 inch cross-section iron.

voltage, as all low tension apparatus and leads are in direct contact with the high voltage windings; also the winding has to be thick enough to stand the full primary current and insulated well enough to stand the full secondary voltage. For this reason an iron cored auto transformer is not used by the ma-

(Continued on Page 26).

Vote No. 1 Wiles' Wires

56-52 GOULBURN ST. (1 door from Pitt St.)
384 PITT ST. (Near Goulburn Street.)
23 PITT STREET, Near CIRCULAR QUAY.

Construct your own Broadcasting Room using Wiles' Wires
office with cash order which are as clear as day

ACCUMULATORS

(Charged ready for use.)

1 v. 50 amp. Exide	22/
2 v. 40 amp. Exide	30/
3 v. 30 amp. Exide	38/
4 v. 20 amp. Exide	46/

BAKELITE

(Cut to any size.)

1/8 in. per sq. in.	1d.
3/32 in. per sq. in.	1 1/2d.

EBONITE

Cut to any size, 1/8 and 3/32, 1 1/2, 1/4 in., 3/16 square inch.

CONDENSERS

(Variable with Dial.)

	Price	Yours
Grimm, 201	15/6	17/
Grimm, 0000	20/6	23/6
Grimm, 0005	10/	12/6
Grimm, 0002	8/	11/6
Warner, 005	—	25/
Warner, 0002	—	20/
Moscow, 002 (incl. 25/)	0005, 12/	

CONDENSERS UNASSEMBLED

Grimm, 002, 5/6; 0005, 6/6; 0003, 1/6; 0007, 1/6;
0004, 1/6; 0003, 1/6

CONDENSERS MERMINEE LOW LOSS

40 Plate
 25/6 |

HONEYCOMB COILS (Mounted)

(Superior Quality)

20 turns, 1/8; 25 turns, 5/11; 30 turns, 5/11; 50 turns, 6/1;	
75 turns, 6/8; 100 turns, 6/8; 200 turns, 6/8; 300 turns,	
7/5; 400 turns, 8/	
Spider Web Coil. Features—	
With Plug, each	1/3
Without Plug, each	5d.

HONEYCOMB COILS, LOW LOSS (Mounted)

10 turns, 3/; 15 turns, 3/; 20 turns, 3/; 25 turns, 4/0;
30 turns, 4/0; 35 turns, 4/0; 40 turns, 5/0; 50 turns,
6/; 25 turns, 6/0

YOU ARE NEVER ALONE

Have the pleasure of making your own
square time, with a more distant, pleasurable,
thoroughly enjoyable evening listening party.

Only the best and specially selected parts
Panel drilled and engraved. The Art work
tones, Headphones, Folding Table, Folding
chair and Operating, which are as clear as day

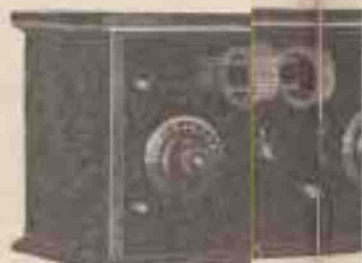

Illustration of 4 Valve Set
advertiser

New Prices of Valve Set Parts

Complete Parts for 1 Valve Set	
Maple Cabinet	
Complete Parts for 2 Valve Set	
Maple Cabinet	
Complete Parts for 3 Valve Set	
Maple Cabinet	
Complete Parts for 4 Valve Set	
Maple Cabinet	

MAIL ORDER DEPT. - 60 GO

OUR GUARANTEE - We guarantee every article you buy from us to be satisfactory in every detail.
return same, with all transportation charges you have paid; we will then exchange for exactly

Wonderful Wireless

ing. We supply complete instructions and clear this you cannot fail to understand.

**SAME QUALITY.
SAME PRICES
SAME SERVICE**

Established
over 20 Years.
Tel. 8822—2 lines

ALONG WITH A RADIO SET

you get Radio Set in a few hours of your own play, and following time, and spend a fitting hobby time from sets, materials, etc. as supplied, including Rechargeable Dry Cell, includes Dry Cell Valves, Battery, Solenoid, Ferris, and Instructions for Assembly also that you cannot fail to understand.



ve Set constructed from parts as advertised.

Set Parts for Home Construction.

valve Set	£6 5 0
.....	1 0 0
valve Set	9 6 0
.....	1 0 0
valve set	12 2 0
.....	1 5 0
valve Set	16 13 6
.....	2 0 0

- 60 GOULBURN ST., SYDNEY

HEADPHONES

Superyellow, 4000 ohms	12/6
Flame, 2200 ohms	20/-
Musical's, 4000 ohms	25/-
Musical's, 2000 ohms	32/6
Bilbourn and Clark, 4000 ohms	32/6
Triffin's, Deponische	35/6
Front, 2000 and	37/6
Fronted	45/-
Western Electric	47/6
Starling	44/-

LOUD SPEAKERS

Amphion	£1, £4/3/6, £5/5/6, £7 & £8
Mechatron	£5/15/-
Magnavox, 25 and	£10/10/-
Osling	£2/10/-, £1/12/6 & £1/10/0
Western Electric	£5/15/6, £3/2/6
Veritas	£8/10/-

VALVES

Hilowan H, Amplifier (hard), English Socket	12/6
Hilowan A.B., Detector or Amplifier (hard), English Socket	12/6
Hilowan A.B.M., Dry Cell type (hard), Detector or Amplifier, English Socket	21/0
Waco, Dry Cell type, Detector or Amplifier, Waco Socket	25/-
Mulford, Dry Cell type (hard), Detector or Amplifier, English Socket	25/-
Mullard, 12K3, Detector or Amplifier, English Socket	25/-
Phillips D2 (hard), Detector, English Socket	33/6
Phillips D2 (hard), Amplifier, English Socket	33/6
Phillips D3 (hard), Detector, American Socket	33/6
Phillips D4 (hard), Amplifier, American Socket	33/6
Phillips D2 (hard), Detector or Amplifier, American Socket	30/-
Phillips DVI Double Grid (soft), English Socket	18/-
Phillips DVI Double Grid Dry Cell type (hard), English Socket	20/-
De Forest DVI (hard), Detector or Amplifier, American Socket	22/6
De Forest DVI (hard), Dry Cell type, Detector or Amplifier, American Socket	22/6
Modified or Cunningham (hard), Detector or Amplifier, American Socket	22/6
W.D. 12 (hard), Detector or Amplifier, Dry Cell type, American Socket	22/6
A.W. 05 Dry Cell type (hard), 100 Socket	22/6
Bilbourn, VV100, Dry Cell type (hard), 100 Socket	22/6

every detail. If for any reason whatever you are dissatisfied with any article purchased from us, you may return it to us, and we will refund your money.

WRITE FOR PRICE LIST AND POST FREE ON REQUEST.

(Continued from Page 23).

majority of experimenters, but for those who are interested in Tungan rectifiers we herewith give the circuit diagram showing the connections, using an auto transformer.

The writer has been using one for the last two years, and it has proved excellent.

For a 200 watt auto transformer rectifier, see Fig. 5.

Fig. 5 explains itself. The core is made up of stalloy iron 1½ in. cross section; 1000 turns of No. 16 or No. 18 d.c.c. is wound on one of the legs; tapings taken at the 9th, 18th, 50th, 100th, 200th, and 300th turn. If the Tungan valve will not oscillate using 2 volts on the filament, viz., 9th turn, place tapping on the 18th turn, viz., 4 volts when the valve starts to oscillate, the temperature is sufficient to keep the valve going on the 9th turn, or it may be taken off altogether.

To increase charge, place plate tapings or increased number of turns. When more than one battery is to be charged at once, the plate voltage must exceed the voltage of the number of batteries in series.

No questions will be given with this article. We thank those of our readers who have sent in their answers to last week's questions. They will be corrected and forwarded back again to them as soon as time permits.

(Editor's Note.—We really had no idea so many people were following these articles. The response to our request for examination papers has been literally overwhelming. They will be treated in their order, and we ask for a little indulgence from those readers whose replies may seem delayed.)

WIRELESS IN HOSPITALS

Some weeks ago, Albert Knowland, a partially blind hawker, who once sold maps in the Strand, was knocked down by a 'bus and taken to a big London hospital. He had been severely injured, both his legs, two ribs, and his left arm being broken. His arm has since been amputated, and his body and legs are still encased in plaster. The plight of this poor old man—Knowland is 64 years of age—was the subject of comment in the "Daily News," when it was pointed out that he had no friends, no money, and there was nothing to distract his mind from the pain of his injuries.

A member of Burndep Ltd. (England) read the "Daily News" report concerning Albert Knowland's condition, and as a result the company decided to instal wireless apparatus by his bedside, and had no difficulty in obtaining the house governor's permission. As will be seen from the photograph, they provided an Ethophone-Duplex and an Ethovox Loud Speaker, with all accessories. The aerial consists of

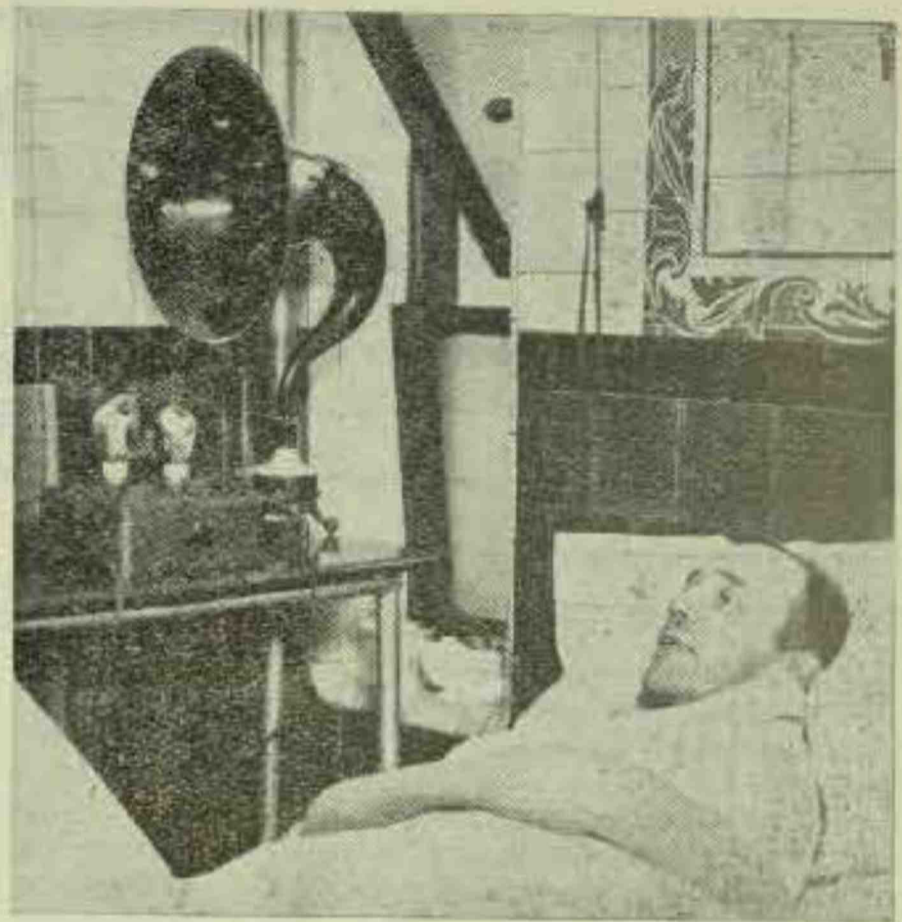

(By permission of the "Daily News," London.)

about 18 yards of rubber-covered wire hung out of a window, and the earth is connected to a water pipe. A frame aerial could not be used, owing to the nature of the walls, which were covered with lead glazed tiles.

When the first sounds of broadcast were heard in the ward and the volume was gradually increased till it seemed as if the announcer was standing at the bedside, the expression in Knowland's eyes and his smile of delight were something which no novelist could describe.

Wireless can bring relief to the sick and suffering by keeping them in touch with the activities of the outside world and giving them the pleasure of hearing music. Indeed, radio may be of material assistance in their recovery.

RADIO WEEK AT TIVOLI

AS a boost for radio, the management of the Tivoli Theatre in conjunction with Farmer's Broadcasting Station (2FC), will run a Radio Week from 13th June to 19th June. The various star acts on the programme will introduce a little radio talk, and in addition the winners of the "Evening News" Competition will be featured in "A peep into a Broadcasting Studio," a specially staged sketch, in which the general public and radio fans will have the opportunity of seeing exactly how a voice is broadcasted. The stage will be set as an exact replica of the broadcasting studio at 2FC station, with Mr. Cochrane, the official announcer in attendance at each performance during the week. Another feature will be the broadcasting at each performance of the broadcasting service of 2FC station.

"True music minor" speakers, thirty-six and six.

BROADCASTING AND COPYRIGHT

IN a recent action in the United States, it is reported that a Judge decided that the broadcasting of songs, etc., did not constitute infringement of copyright. The following account, taken from the "Radio Manufacturer," shows how this decision was reversed.

The United States Circuit Courts of Appeals in a decision handed down declared that the broadcasting of a song constituted a violation of the Copyright Act. This was a reversal of the decision handed down some time ago by Federal Judge J. Hickenlooper, who dismissed the suit of the Jerome H. Remick & Co., against the Crosley Radio Corporation.

In reversing the lower court, Judges Julien W. Mack, Arthur C. Denison and Maurice H. Donahue, of the Court of Appeals said:

"While the fact that the radio was not developed at the time the Copyright Act was enacted in 1909 may raise some question as to whether it properly comes within the purview of the statute, it is not by the fact excluded by the statute. In other words, the statute may be applied to a situation not anticipated by Congress, if fairly construed and such situation comes clearly within the intent and meaning of the statute.

"Bills have been introduced in both House and Senate to permit broadcasting without infringing copyrights. The rights of composer, performer and the public under this new method of reproduction are eminently matters for considered Legislation; but until Congress shall have specifically determined the relative rights of the parties, we can but decide whether and to what extent statutes covering the subject-matter generally, but enacted without anticipation of such radical changes in the methods of reproduction, are, if fairly construed, applicable to the new situation."

"A performance in our judgment is no less public because the listeners are unable to communicate with one another, or are not assembled within an enclosure or gathered together in some open stadium or park or other public place. Nor can a performance, in our judgment, be deemed private because each listener may be alone in the privacy of his home. Radio broadcasting is intended, and, in fact, does reach a very much larger number of the public at the moment of the rendition than any other medium of performance. The artist is constantly addressing a great and widely scattered audience and is therefore participating in a public performance.

"That under the Copyright act a public performance may be for profit, though no admission fee

HOWELL'S Sale & Exchange

FOR
THE LATEST
AND
BEST
IN
WIRELESS
AT
LOWEST
PRICES

19 Barlow Street
SYDNEY

PHONE : M A 1133
OPEN TILL 9.30 FRIDAY NIGHT

Up to the Minute
Progress in Radio

QST

A Magazine Devoted
Exclusively to the
Wireless Amateur.

Published Monthly.
Subscription, 20/- per
annum, post free.

Distributor for Australia:

Phil Renshaw
DALTON HOUSE,
115 Pitt Street, Sydney
Box 2816, G.P.O., Sydney.

VACUUM TUBES In Wireless Communication

A Practical Text Book
for operators and experi-
menters

By

Elmer E. Bucher

This volume shows over
140 different circuits for
the practical use of
vacuum tubes as detec-
tors Radio or Audio Fre-
quency Amplifiers, Re-
generative receivers
Beat Receivers, etc.

Price 12/6, Postage 8d.

N.S.W. Bookstall Co. Ltd.
Corner, Castlereagh and
Market Streets,
Sydney.

is exacted or no profit actually made is stated in *Herbert v. Shanley*, 242 U. S. 591. It suffices, as there held, that the performance be for profit and not eleemosynary; it is against the commercial as distinguished from the purely philanthropic use of another's composition that the statute is directed.

"it is immaterial, in our judgment, whether that commercial use be such as to secure direct payment for the performance by each listener or indirect payment as by a hat-checking charge when no admission fee is required, or a general commercial advantage as by advertising one's name in the expectation and hope of making profit through the sale of one's products be they radio or other goods."

The case is remanded to the lower court for further proceedings.

THE PROOF.

WHETHER or not advertising in "Wireless Weekly" pays is illustrated in the following copy of a letter from Parsons & Whittemore Ltd., agents for the well-known "True Blue" valves. This testimonial was quite unsolicited by us:—

11/5/25.

The Editor,

"Wireless Weekly."

Dear Sir,—We feel sure you will be interested in hearing our appreciation of your paper as a successful advertising medium. This we have proved by our increasing sales. It also illustrates the "quality" of your readers, who, it appears to us, are demanding the highest class of Radio goods of every description.—Yours truly,

W. T. MALING,

(Managing Director),

PARSONS & WHITTEMORE LTD. (Sydney).

1YB NEW ZEALAND

In a letter to us, Mr. C. H. Pearson, Managing Director, La Gloria Gramophones Ltd., Newton, Auckland, the concern which owns and operates 1YB, asks us to explain that 1YB is a private broadcasting station. At present a 50 watt plant is used but a much larger outfit is in course of erection. Transmissions take place on Sunday, Wednesday and Saturday evenings on a wavelength of 260 metres and although the programmes consist primarily of gramophone records, they are frequently interspersed with Bedtime Stories, Church Services and concert parties.

Mr. Pearson will be visiting Sydney during the course of a few weeks and will be pleased to hear

from those who hear his station regularly. During his visit to Sydney special programmes will be run from 1YB and as Mr. Pearson is anxious to listen-in on a set over here, would any reader who could arrange this kindly drop a line to him c/o this paper.

ARE YOU ON THIS LIST?

The following list of stations were heard on a one and two valve low loss set by A4DO, H. L. Hobler, Rockhampton, Q.:

Queensland.—4CM, 4CK, 4GE, 4AN, 4EG, 4LA, 4RQ, 4KR, 4CU, 4CF, 4AC, 4UG, 4HR, 4RB, 4HB, 4GD, 4FA.

N.S.W.—2BL, 2FC, 2HM, 2GQ, 2HF, 2CM, 2CR, 2ZZ, 2GR, 2GY, 2AY, 2YG, 2BK, 2QG, 2LO, 2YL, 2DS, 2RJ, 2KO, 2BF, 2YB, 2SR, 2YR, 2IJ, 2CS, 2YA, 2RA, 2BB, 2ME, 2CL, 2JM, 2KC, 2ZN, 2XA, 2DE, 2WS, 2JS, 2CX, 2HS, 2RG, 2DB, 2YF, 2CU, 2UN, 2RS, 2CG, 2JR, 2XK, 2GM, 2BV, 2CJ, 2JT, 2UI, 2DJ, 2VX, 2SP, 2SS, 2WW, 2HT, 2EC, 2UW, 2CH, 2DG, 2DN, 2TW, 2BC, 2GC, 2CF, 2UE, 2WB, 2LM, 2ZU, 2GN, 2FA, Riverina Wireless Supplies and 2BL ex. stn.

Victoria.—3AR, 3BM, 3OT, 3XF, 3LM, 3EF, 3BD, 3EM, 3LO, 3RY, 3YX, 3BQ, 3CQ, 3JU, 3TM, 3JH, 3LF, 3CB, 3AP, 3YZ, 3HH, 3JM, 3BF, 3CS, 3HL, 3ST, 3KT, 3HD, 3PM, 3YY, 3AD, 3LS, 3XO, 3ZN, and 3CF.

South Australia.—5WJ, 5LO, 5AD, 5BF, 5CF, 5DO, 5AG, 5BG, 5BN, 5RM, 5SF, 5LH, 5JC, 5DA, 5BD, 5AC, 5ZD, 5RG, 5DN and 5CM.

West Australia.—6AM.

New Zealand.—1YA, 4AP, 4AD, 4AA, 2AP, 3AF, 2AA, 4AK, 4AR, 3AL, 2AC, 1AO, 4AG, 1AA, 2AW, 3AO, 2AE, 2AU, 3AB, 2XA, 2BX, 2AB, and 2AQ.

U.S.A.—KGO, 4NAI, 6XI, 1TAO, 9DAW, 7FQ, 6EA, 7UJ, 6AJI, 6AWL, 6SJB, 1PL, 5EW, 4JY, 5ACL, 9BKR, 2RK, 6WPB, 1RD, 6CHS, 6BBQ, 6CWR, 4ON, 5LR, 6CTO, 6VC, 6VUC, 6CDB, 9ADO, 6CGW, 1AJK, 4TJ, 3AM, 6CMU, 4GT, 6BNB, 6BBC, 3HG, 5BA, 6ALD, 6BWW, 7DF, 7AFO, 6BIK, 5AUL, 1AF, 7MF, 6ALR, 1CMP, 6NO, 9ZT, 2DS, 9CK, 9ELI, 9CUC, 7IJ, 9CYD, 2CTF, 6AWT, 3AP, 2RM, 6RW, 2CJB, 1AA, 6LJL, 3CHG, 6CTK, 9CPO, 5MS, 5OV, 6CHX, 6BES, 6EW, 6BAQ, 6XG, 2JS, 6ZH, 6AKW, 7BR, 6AFG, 6CQE, 6CAQ, 3AB, 6GSN, 9DQR, and 9BDU.

Canada.—5BA, 5OX, 4GT, 5GO.

Samoa.—6ZAC.

England.—2LZ, 2NM.

Dutch East Indies.—ANE.

Unknown.—NIRX and J-1AA.

Papua.—4LC.

"True music" loud speakers sing sweetly.

MADE BY



The Man who Invented Broadcasting

25s. each



De Forest Valves

TYPE D.V.2—Takes 5 Volts at $\frac{1}{4}$ Amp. on Filament 25/- each

Plate Voltages, Detector .. 18-22½ Volts

Plate Voltages, Amplifier 60-150 Volts

TYPE D.V.3—Takes 3 Volts at .06 of an Amp. on Filament 25/- each

Plate Voltage, 16-22½ Volts, Detector

Plate Voltage, 60-120 Volts, used as an Amplifier.

Both Types Fit Standard American Socket.

D.V.3
Filament, 3 volts
.06 amp.
Both Types Fit Standard American Socket.

D.V.2
Filament 5 volts
.25 amp.

(Wholesale Only)

INTERNATIONAL RADIO CO. LTD.

200 Castlereagh Street Sydney, N.S.W. Phone: MA 1387

Also at 91-93 Courtney Place, Wellington, N.Z.

THE MODIFIED CRYSTOTRAP

By "Poldhu."

IN the issue of May 15th, I described the "Crystotrap" which was designed to give perfect crystal reception without any interference from unwanted stations. The crystal set described in this article is a modification of the "Crystotrap" with the addition of a stage of audio-frequency amplification. This will not increase the range but will build up the signals when they have been rectified by the crystal. Selectivity is the one point to keep in mind in all radio receiving sets and particularly is this the case with a crystal set. Many are content to listen to a program mutilated by commercial stations, but by the judicious use of traps this nuisance can be entirely avoided. Selectivity is best obtained by the use of coupled circuits; a circuit between the receiver, and the aerial is generally necessary so that interfering impulses can be "absorbed" by the additional circuit. The only additional cost to that of an ordinary receiver is that of a good condenser and a coil of suitable dimensions—surely a small expenditure for such a worthy purpose. Such a wavetraps is shown in Fig. 1. This consists of a condenser and coil of suitable dimensions to cover the band of wavelengths of the interfering stations. This is not the only form of wave trap, but it is quite a useful one as it can be adapted to practically any receiver. You will do well to disabuse your mind of the popular fallacy that interference can be cut out merely by the use of a loose-coupler. Occasionally it can be, but the loose-coupler is not an infallible means of doing the trick, and very frequently it is necessary to diminish the signal strength of the broadcaster to do so.

The materials necessary for this set are:

1 piece of Bakelite or Radion, 10in. x 8in. x 1/8in.

1 Baseboard 8in. x 9in. x 1in.

1 Cardboard or ebonite former 4in. diameter and 7½in. long

1 .0005 variable condenser and dial

- 1 audio frequency transformer
- 1 valve and socket
- 1 rheostat
- 2 terminals
- 2 B battery clips
- Busbar for wiring
- 1 telephone jack
- 1 .001 variable condenser and dial
- 1 crystal detector
- 1 galena crystal
- ½lb. No. 24 d.c.c. wire
- 1 switch arm and stops
- 7 switch studs.

First square up your bakelite and then plan it out according to diagram 3.

Setting out the panel and assembling the parts

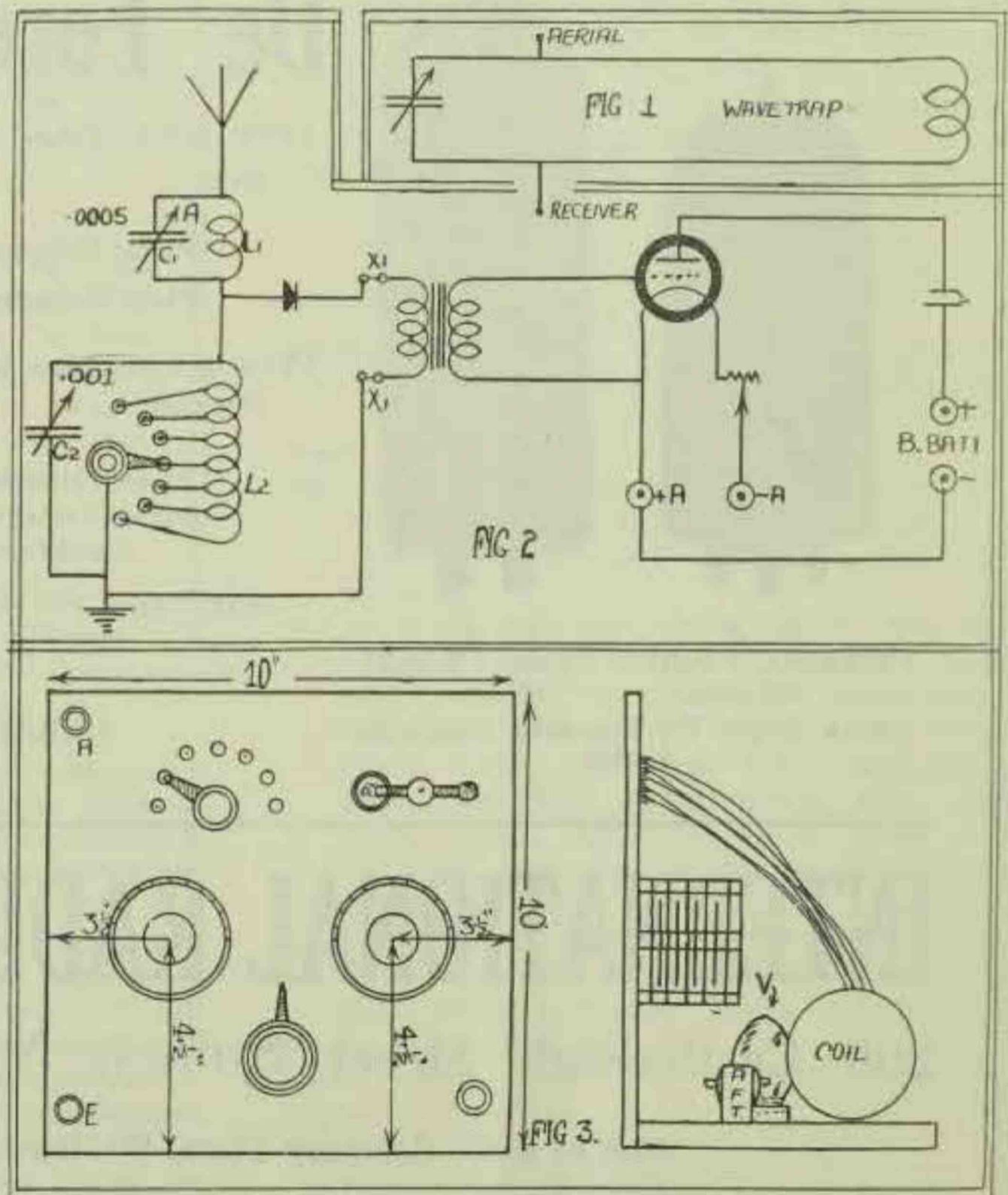

New System intercommunicating telephones make for bigger business

should present no difficulty, except in spacing, and this difficulty can be overcome if the diagram is carefully studied. Now take the cylindrical former. Commence $\frac{1}{2}$ in. from one end and fasten securely one end of the wire and then wind on it in as small a space as possible, 35 turns of wire. No attempt need be made to wind this section evenly, just wind it as closely as possible and then without breaking the wire, fasten it and commence to wind the next section. This should be wound evenly in a single layer and should consist of 150 turns tapped at 30, 50, 70, 90, 100, 120 turns. Wires are to be taken from each tapping pigtail to the studs, the end wire—not the beginning—going to the last stud. In spite of many warnings to the contrary I am going to advise you to shellac the whole coil—it will not suffer much in efficiency by reason of any increased self capacity on account of the shellac.

Now we are ready for the baseboard. Square up carefully, give a good rub up with some glass paper and give it a couple of coats of shellac. Screw the coil on to the back of the baseboard, allowing sufficient room for condensers, valve, and audio frequency transformer. Mount the latter on the base at any convenient position. I cannot dogmatise on the right positions on account of the different sizes of the various parts, so just please yourself. Now screw the panel to the baseboard, put a brass bracket to secure a rigid panel and you are ready for the wiring operation. Your first wiring will be from the studs to the tapplings on the coil. On the coil are six pigtails each about $\frac{1}{2}$ in. in length, two ends and a wire joining each section of the coil. Take the beginning of the 35 turn section, join it to the aerial terminal and join the other end of the 150 turn coil to the end stud. Then bare each pigtail carefully, using a sharp penknife. Solder a piece of flex on to each of the six remaining studs and then, pulling taut, solder the other end to a pigtail. Be careful to take the pigtails in order, so as to have an increase of inductance when the switch arm is turned in a clockwise direction. A lead is now taken from the fixed plates of condenser C1 to the aerial terminal and one from the moving plates to the wire joining L1 and L2. The beginning of L1 goes to the aerial. Similarly a wire from the fixed plate of C2 passes to the same point and one from the moving plates to the switch arm. A lead from the wire joining L1 and L2 is taken to the crystal cup and one from the crystal arm to the terminal in the audio frequency transformer marked "P"; from the terminal in the transformer marked "B Batt." take a lead straight to earth. A lead from the switch arm also goes to earth. A .001 m.f. fixed condenser is sometimes placed across the "P" and

B Batt. terminals with advantage though it may not always appear to be necessary. That finishes the detector part of the circuit and we must hurry on to the amplifier if we are to listen in to Saturday's programme. The wiring of an audio frequency amplifier is very simple because the components are always clearly marked and it is difficult for one using average care to go wrong. Take a wire from the terminal on the audio frequency transformer (A.F.T.) marked G to G on the valve socket. From the plate take a lead to one lug of the telephone jack. From the base of the jack take a flexible lead with a good strong spring clip on the end to the positive B battery. From the negative B battery take a lead to the positive A battery. The rheostat is placed in the negative lead from the A battery. A condenser across the phones and B battery with a value of .001 m.f. is an advantage. Now I think the wiring is complete. Just take a glance over the circuit diagram and also the wiring instructions and check up your set.

The working of the set follows closely instructions given last week for Crystotrap. The trap circuit A is designed to absorb unwanted station, while the main tuning for broadcasting is done by means of the circuit B. Suppose we want to listen in for 2FC. I found that on my aerial—about 80 feet in length—it was necessary to move the switch arm to the 6th stud and then make a final adjustment in condenser C2. For most aerials used in broadcast reception, this will be the approximate position of the switch arm. Clean up your crystal with petrol if it is at all greasy or dirty and then you are ready. Turn on the rheostat of the A battery circuit and clip on your B battery. Be patient in your tuning and you will be rewarded with good clear signals from 2FC. Now at 8.30 p.m., in comes VIS with his weather report and ocean forecast. This is the opportunity your wave trap has been waiting. Alter the adjustment of C1 carefully and you will find a position when the interference will be eliminated. The condenser C2 may perhaps require a little re-adjustment, but you will soon secure an adjustment between C1 and C2 when VIS will be entirely cut out and 2FC will be perfectly clear and strong.

The adjustment of the amplifying stage is secured by making correct values of A and B batteries. This is done by varying the current of the A battery by the rheostat and the voltage effect of the B battery by the position of the clip. One point is of importance in both these adjustments—use as little current in the filament and voltage on the plate as is consistent with good signal strength.

Continued on Page 33

Write for our New Radio Catalogue which gives circuits and Prices for all component parts

SPECIAL PURCHASE

1000 pairs Genuine Repeater HEADPHONES

21/-

Usual Price 30/-

CALL AND HEAR OUR SETS AND LISTEN TO THE CLEAR RECEPTION.

PRICES RANGE from £8 for a 1 valve set to £75 for a 5 valve set.

B Batteries.

Ever Ready Batteries, 9/6, 12/6, and 21/-.

WINCHESTER.

22½ V., large capacity cells	13/-
45 V., large capacity cells	26/-
201A and 199 Valves	22/6
Dutch Valves	8/6 ea.

GENUINE BAKELITE—Cut to all sizes and drilled free if parts are purchased here.

New Gramophone Radio Combination

Its tone will satisfy the musician and its appearance will beautify the home.

MAKES ENTERTAINMENT AT HOME EASY

Terms Arranged if Required

ENQUIRIES INVITED FROM COUNTRY CUSTOMERS.



Remember our Motto—Quality Consistent with Reasonable Prices

Headquarters: HAYMARKET, SYDNEY
THE WORLD'S GREATEST SPORTS STORE

Q.S.L.

The meaning of the three letters QSL is: "Please give me a receipt" — or, in other words—"Send me an acknowledgement."

There isn't a transmitter on the air now who is not glad to get a report on his signals, whether they are phone or C.W.

You can put everything you want to say on a Publicity Press QSL card. It takes only a minute to fill in and conveys all the information the transmitter wants.

Over the last few months we have printed thousands of these cards for both transmitters and receivers, among them 2UW, 2CX, 2BF, 2LM, 2WW, 4CK, etc.

There is a QSL card for every purpose and they may be had either from stock or to suit individual tastes.

Write, phone or call.

Publicity Press Ltd.

Printers and Publishers -

12-16 Regent Street
SYDNEY

Phones Red. 964 & 930.

(Continued from Page 31.)

When the signals are strong, reduce the current by turning the rheostat until a further turning decreases the signal strength. One point is rarely mentioned in the descriptions of set construction, and that is the cost. This often proves a valuable incentive or deterrent in set construction. I have carefully worked out the cost of this set and find that about £7 will cover the whole cost, using good components.

In conclusion I can recommend this set to the great army of "crystals" who are anxious to graduate to the valve army. One point I almost forgot. If the crystal is to be used without the amplifier it can be broken at XX and similarly the amplifier will work satisfactorily without the crystal if attached to any rectifying circuit.

Telephone B 5925

CHARLES D. MACLURCAN

Consulting Radio Engineer

Pizzetti Building,
26 Jamieson Street,
SYDNEY

CALIBRATIONS

ROUND THE CLUBS

(Continued from Page 10)

on Thursday, the 4th proximo, at a place to be advised later. The question to be debated resolves itself into a discussion of the relative merits of State Control or private control in connection with the new Queensland Broadcasting Station 4QG. South Brisbane will oppose the desirability of private control and an amusing evening is assured. Members of other nearby Clubs are invited to be present and further particulars may be obtained from the Secretary of either Club concerned. W. Finney, Esq. (ex Radio Inspector of Queensland), has consented to adjudicate.

The Wooloowin Radio Club's transmitter is gradually being completed and the transmitting helix is now ready for use. The technical committee (Messrs. Buck and C. Stephenson) have been authorised to take any necessary steps necessary to expediate early transmissions from 4WN.

Next meeting—Thursday, 28th May—will be an Impromptu Night—when each member will be expected to speak for five minutes without preparation on a subject drawn from the hat.

All intending members are welcome and should communicate with the Hon. Secretary (Mr. H. A. Jiear), Lisson Grove, Wooloowin.

Repairs & Service

Realising the necessity and the demand for repairs to existing equipment we have installed a **Repair and Service Division** in our Wireless Dept. which is available to the Public.

REPAIRS. We can repair Head-phones, Loud Speakers, rewire broadcast receiving sets—test, locate and rectify any trouble in any set, and generally perform all repairs (except rewinding audio frequency transformers).

SERVICE. We have an expert staff available to instal—repair or inspect any receiver at any place at all reasonable times.

All work carried out at Moderate Cost by Experts.

Satisfaction assured if our Advice is followed.

Burgin Electric Co. Ltd.

Wireless Manufacturers and Suppliers
340 KENT STREET — SYDNEY

Cut this out.

Please send by return, particulars of your "Repair and Service."

Name

Address

W/5/25.

(Continued from Page 16.)

9.30—Mr. George Dalton—

(a) Red Hot, Mamma.

(b) Me and the Boy Friend.

9.40—Speech.

9.50—Miss Hilda Grace:

(a) Where the Lazy Daisies Grow, and

Follow the Swallow (Fox Trots).

(b) All Alone, and

I Wonder What's Become of Sally (Waltzes).

10.0—Speech.

10.10—Miss Hilda Grace:

Doodle Deo Deo, and

It Had To Be You (Fox Trots).

Rock-a-bye Baby Days.

10.15—National Anthem.

The audience to this programme promises to be a large one. In spite of the low power of the station (20 watts), 2UW is regularly heard in New Zealand and the other States. A digest of a few letters handed to the writer was published last week

in this paper, and was taken at random from a great pile of correspondence received by Mr. Sandel.

In view of this it is to be expected that the programme on Friday will be listened to by many thousands of men and women throughout Australia and New Zealand. The station itself is of great interest, especially in view of the low power being used. The studio is carefully draped in order to eliminate echoes, but at the same time not so heavily draped as to deaden the voice. The aerial is 80 feet high, the station being situated on the highest point of Bellevue Hill. Mr. Sandel has been granted permission to use 500 watts power, and it is to be hoped that he soon has his full power on the air, as, judging by his present performances, his station will then be as efficient as any in the land. The wavelength of the station is 267 meters.

In conclusion, we should congratulate Mr. Sandel in his pioneering work, and hope that before long we have other stations giving us still greater variety to our excellent nightly entertainment.

GILFILLAN RADIO PARTS

The Parts you Must have to build a Thoroughly Efficient RADIO RECEIVING SET

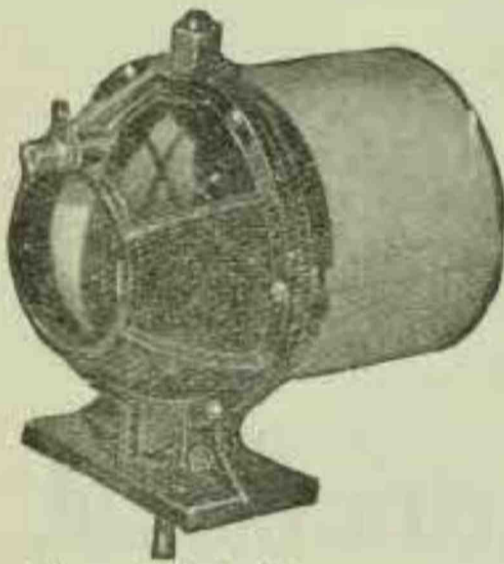

VARIOCOUPLER SMALL SIZE

R 650 A — Plain Winding

R 650 B — Bank Winding

The plain wound vario coupler carries three separate windings; one being on the inside of the spherical shell. This

internal winding may be used as a tickler coil or to increase the wave length range. The bank wound coupler is not provided with the internal shell winding, as sufficient wave length range is provided for in the stator winding.

UNUSUAL EXCELLENCE

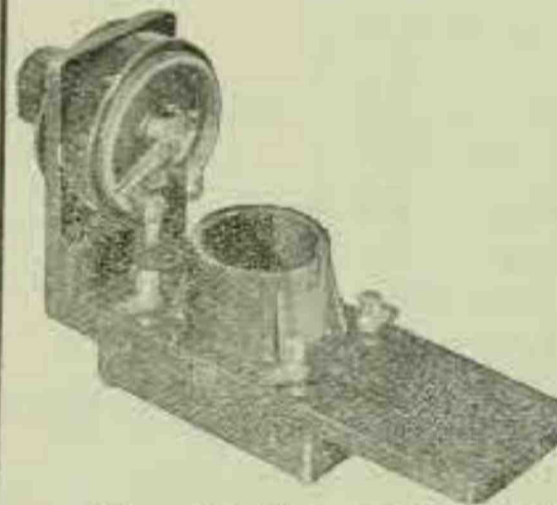

DETECTOR UNIT

The detector unit comprises tube socket, filament rheostat of 20 ohms resistance, dial and knob, binding posts and solder lugs.

Jack can be mounted directly to bottom of unit

so making very short leads possible and adapting the part to radio frequency circuits. Also very desirable for audio frequency receiving sets. Rear platform may be drilled to carry binding posts to which leads from battery, etc., may be attached.

REASONABLE COST

Harringtons 

Photo and Radio
Warehouses

SYDNEY—386 George Street.

BRISBANE—93 Queen Street.

KATOOMBA—Katoomba Street.

WELLINGTON, N.Z.—42 Willis Street.

MELBOURNE—266 Collins Street.

ADELAIDE—10 Rundle Street.

AUCKLAND, N.Z.—140 Queen Street

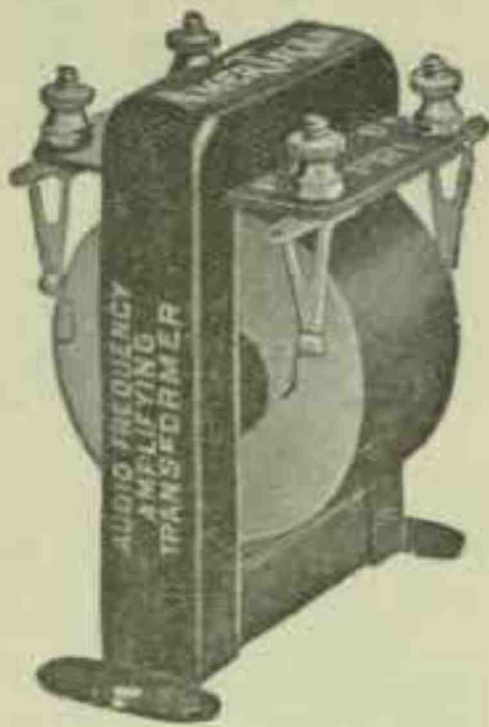

"IMPROVE YOUR SET WITH AN AMERTRAN"

You are sure of the best results only by using the best Transformer

"AMERTRAN"

Squeals and howls in audio transformers are due to regeneration between the tubes and the amplifiers. To get rid of this trouble, very careful wiring is necessary. The grid and plate leads must be short and straight, and the other wires of the set must be grouped together. Insulated wires should be used, if possible. A proper "C" battery should be used in the grid circuit of each tube to match the first battery used in accordance with directions given with the transformer. Also, squeals may be avoided by placing a resistance of $\frac{1}{2}$ megohm across the secondary of the last transformer. Capacity should not be placed across the secondary, but may be placed across the primary. This capacity may be as high as .004 M.M.F.

Australian Distributors:

WELBY RADIO CO. 13 ROYAL ARCADE, SYDNEY

You can Depend Upon

EDISWAN VALVES

Guaranteed by the Manufacturer

Sold by all Leading Dealers

PATON

4463

NONE BETTER ALL BRITISH

THE Name Ediswan is your protection—you have the manufacturers' guarantee with each valve. A list including four different types of receiving valves and two power valves at the reduced prices now in operation is shown below.

Bright Emitter.	Dull Emitter.
A.R. 12/6	A.R.06 . . . 22/6
R. 12/6	A.R.D.E. . . 21/-

Power Valves.

P.V.3	25/-
P.V.D.E.25	25/-

Buy Ediswan — Hear Everything

Broadcasting

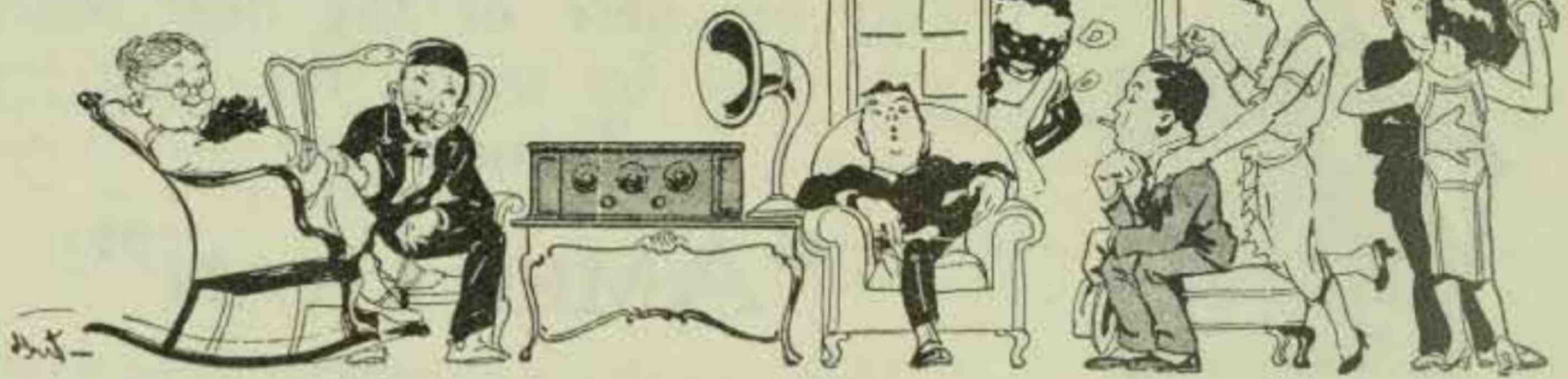

2FC

FARMER'S BROADCASTING SERVICE.

WAVELENGTH, 1100 METRES.

THURSDAY, 28th MAY.

Morning Session: 10.15—Weather Information, Commercial News, Cables, Domestic, Fashion and Garden Talks, Health Hints, Daily Menu. 11.15—Close down.

Midday Session: 12.30—Midday News, Market and Weather Reports, Sporting Information. 2.0—Close down.

Afternoon Session: 3.0—Afternoon News, Cables and Commercial Reports, Readings and Afternoon Concert, Sporting Information. 4.30—Close down.

Early Evening Session: 6.30—Children's Hour. 7.15—Late Market, Weather and Commercial News, Late Sporting Information. 7.30—Close down.

Night Session: 7.30—A Y.M.C.A. Talk. 7.45—Proportional Voting Explained. 8.0—Sydney Madrigal Society. Choir of 100 picked voices. Broadcast from Beale's Concert Salon. 8.30—2FC Brass Quartette. 8.38—Miss Vinia de Loitte and Mr. Frederick Hughes in Comic Opera Recollections. 8.50—Mr. Harry Thomas, elocutionist. 9.6—Interval. 9.10—2FC Brass Quartette. 9.20—Miss Vinia de Loitte, soprano. 9.25—Mr. Frederick Hughes, baritone. 9.30—2FC Brass Quartette. 9.40—Miss Vinia de Loitte and Mr. Frederick Hughes in Comic Opera Recollections. 9.50—Wentworth Hotel. Jazz Music. 10.30—Close down. Prof. Morris Miller will talk on "Studies from a Psychological Clinic."

FRIDAY, 29th MAY.

Morning Session: 10.15—Weather Information, Commercial News, Cables, Domestic, Fashion and Garden Talks, Health Hints, Daily Menu. 11.15—Close down.

Midday Session: 12.30—Midday News, Market and Weather Reports, Sporting Information. 2.0—Close down.

Afternoon Session: 3.0—Afternoon News, Cables and Commercial Reports, Reading and Afternoon Concert, Sporting Information. 4.30—Close down.

Early Evening Session: 6.30—Children's Hour. 7.15—Late Market, Weather and Commercial News, Late Sporting Information. 7.30—Close down.

Night Session: 7.45—A Chess Talk. 8.0—Broadcast from the Theatre Royal, Sydney, by permission of Messrs. J. C. Williamson Limited, the first act of the New Musical Play, "The Lady of the Rose." Music by Jean Gilbert. Gladys Moncrieff as Mariana, Claude Flemming as Colonel Belovar, Leslie Holland as Baron Sprotti-Sprotti, Blake Adams as Sui-

tangi, Jack Ralston as Major Stogan. Scene: The Palm Court of the Castle Beltrami (afternoon). 9.5—Broadcast from Town Hall, reception to English Soccer Team. Artists: Mabel Batchelor (soprano), R. M. Baxter (tenor). Organ Recital, Violin Solos, Community Songs. 10.0—Close down.

SATURDAY, 30th MAY.

Morning Session: 10.15—Weather Information, Commercial News, Cables, Domestic, Fashion and Garden Talks, Health Hints, Daily Menu. 11.15—Close down.

Midday Session: 12.30—Midday News, Market and Weather Reports, Sporting Information. 2.0—Close down.

Afternoon Session: 3.0—Afternoon News, Cables and Commercial Reports, Readings and Afternoon Concert, Sporting Information. 4.30—Close down.

Early Evening Session: 6.30—Children's Hour. 7.15—Late Market, Weather and Commercial News, Late Sporting Information. 7.30—Close down.

Night Session: 8.0—Broadcast from the King's Hall, Sydney, by courtesy of the Management, the Recital by Mr. Arthur Jordon, the distinguished English tenor, late with the Elsa Stralia Company. Mr. Jordon will sing several groups of modern British songs, together with operatic and ballad numbers. Assisting artists will be Mr. Gladstone Bell (cellist), Mr. Lindley Evans (pianist), Mr. Lionel Lawson (violinist) Mr. Vern Barnett (accompanist). 10.15—Dance Music from the Wentworth Hotel to midnight. 12.0—Close down. During the evening the progress results of the N.S.W. Elections will be broadcast at intervals.

SUNDAY, 31st MAY.

Morning Session: 10.55—The Chimes of 2FC. 11.0—The first Sunday Morning Service from 2FC will be taken from St. Mark's Church of England, Darling Point. Preacher: The Rev. Howard Lea. The Bishop of North Tokio will deliver an address. 12.30—Close down.

Afternoon Session: 2.55—The Chimes of 2FC. 3.0—Broadcast from the Petersham Congregational Church, a Musical Recital arranged by Mr. Christian Hellemann (organist). 4.30—Close down.

Evening Session: 6.55—The Chimes of 2FC. 7.0—Church Service from the Petersham Congregational Church. Rev. A. P. Doran. 8.25—Interval. 8.30 to 12.0—The Metropolitan Band will play during the evening from the Studio, assisted by Miss Elsie Peerless (soprano), Mr. Alex Whitson (baritone), Mr. Ewart Chapple (pianist). The N.S.W. Election Results will be transmitted at intervals till counting ceases at midnight.

Have you got your Philco yet?

MONDAY, 1st JUNE.

Morning Session: 10.15—Weather Information, Commercial News, Cables, Domestic, Fashion and Garden Talks, Health Hints, Daily Menu. 11.15—Close down.

Midday Session: 12.30—Midday News, Market and Weather Reports, Sporting Information. 2.0—Close down.

Afternoon Session: 3.0—Afternoon News, Cables and Commercial Reports, Readings and Afternoon Concert, Sporting Information. 4.30—Close down.

Early Evening Session: 6.30—Children's Hour. 7.15—Late Market, Weather and Commercial News, Late Sporting Information. 7.30—Close down.

Night Session: 7.30—Safety First Talk. 8.0—Chamber Trio. 8.10—Rayne and Powell, English Harmony Duo. 8.25—Lionel Lawson, violinist. 8.33—Percy Marks will talk on Pearls. 8.45—Old London Street Cries, presented by Madam Emily Marks (soprano) and described by Mr. Bowden. 9.18—Chamber Trio. 9.30—Mr. Frank Walker will give Historical Talk on the first N.S.W. Governor, Captain Arthur Phillips. 9.40—Lionel Lawson, violinist. 9.45—Rayne and Powell, English Harmony Duo. 10.0—Close down. Mr. A. Duncan Hall, delegate to the Pan-Pacific Congress, will talk.

TUESDAY, 2nd JUNE.

Morning Session: 10.15—Weather Information, Commercial News, Cables, Domestic, Fashion and Garden Talks, Health Hints, Daily Menu. 11.15—Close down.

Midday Session: 12.30—Midday News, Market and Weather Reports, Sporting Information. 2.0—Close down.

Afternoon Session: 3.0—Afternoon News, Cables and Commercial Reports, Readings and Afternoon Concert, Sporting Information. 4.30—Close down.

Early Evening Session: 6.30—Children's Hour. 7.15—Late Market, Weather and Commercial News, Late Sporting Information. 7.30—Close down.

Night Session: 7.45—Dr. Woolnough will talk on behalf of the N.S.W. Wireless Institute of what wireless means to those outback. 8.0—Mrs. Garnor will talk on "Bridge." 8.15—A Scotch Night, arranged by the Highland Society of N.S.W. in conjunction with Mr. J. Brasch. Pipe Band, Scotch Songs, Highland Choir, Scotch Humour. 10.0—National Anthem. Close down.

WEDNESDAY, 3rd JUNE.

Midday Organ Recital by Miss Lillian Frost will be broadcast from the Pitt Street Congregational Church. This is the 451st Recital and the 12th Anniversary of these interesting concerts. The artists will include Mr. Lawrence Campbell (elocutionist), Mr. Henry Stael (violinist), and Madam Emily Marks (soprano).

In the afternoon will be broadcast direct from the Royal Agricultural Show Ground a complete description of the Soccer Match between the English and Metropolitan teams. A qualified announcer will describe the match in detail.

The evening session will include the Chamber Trio, a talk on Golf, violin solos by Mr. Lionel Lawson, songs and duets from Messrs. Haines and Bannon, a talk by Mr. S. H. Bowden on "The Leaning Tower of Pisa," and other Studio items.

ELECTIONS.

2FC are making elaborate arrangements for the broadcast of the Election Results. The service on Saturday, 30th, and Sunday, 31st, will be continued until midnight, and a musical programme kept going, during the intervals of which results will be announced.

2 UW

267 METRES

THE programme for next Sunday, (May 31st).

7-7.30 p.m., Childrens' Hour.

Bedtime Stories by Uncle Otto.

Recitation by Jean Penticost.

Piano Solos by Thelma Upton.

8 p.m. Miss Ada Althouse (Piano).

Minute Waltz.

8.5. Miss D. Allen (Soprano).

(a) Melisande in the Wood.

(b) Five Little Piccaninnies.

Mr. Bernard (Tenor).

(a) "Hills of Donegal."

(b) "Red Devan by the Sea."

8.25. Miss Jean Kennelly (Soprano).
"Mifanwy."

8.30. Miss Ada Althouse (Piano).

Miss Doreen Douglas (Violin).

Popular Numbers.

8.40. Mr. Harold Bennett (Tenor).

"The West, a Nest, and You."

8.45. Miss Gwendoline O'Reilly.

"Negro Baby's Funeral."

8.50. Miss Doreen Douglas (Violin).

(a) "Cavatina."

(b) Lullaby.

9 p.m. Interval.

9.5. Miss Jean Kennelly (Soprano).

(a) Il Trovatore.

(b) Waltz Song from Tom Jones.

9.15. Mr. Bernard (Tenor).

Selected.

9.20. Miss Ada Althouse.

(a) Villanelle.

(b) Mussetta's Aria.

9.30. Miss Doreen Douglas (Violin).

Rando Capriccioco.

9.35. Miss D. Allen.

(a) Summer Night.

(b) Turn Once Again.

9.45. Miss Ada Althouse (Piano) and Miss Doreen Douglas (Violin).

Popular Numbers.

9.55. Grand Finale.

10 p.m. National Anthem.

The "New System" 'phone is matched in tone.

"Perfection Detection"
"Ample Amplification"

G. & R. 77

The World's Best Valve"

Filament Voltage

4/5

Filament
Current

.26 amps.

PRICE

17/6



Plate Voltage

30, 100

Plate Current

1 milliamp
at 60 volts

PRICE

17/6

Ask for the Double Seven

English or American Base

Sole Selling Agents for Australia:

NEW SYSTEM TELEPHONES PTY., LTD.

280 Castlereagh St.,
Sydney

25-27 Queen's Bridge St.,
Melbourne

M 3230 Phones Cent. 11130

2 BL

BROADCASTERS (SYDNEY) LIMITED SERVICE.
CALL SIGN, 2BL. WAVELENGTH, 353 METERS.

THURSDAY, 28th MAY.

Early Morning Session: 8.0—News Items. 9.0—
Close down.

Morning Session: 11.0—Social Notes. 11.15—
Music from the Studio. 12.0—Weather and Commer-
cial Reports, Music from the Studio. 2.0—Close
down.

Afternoon Session: 3.0—G.P.O. Clock Chimes.
Music from the Studio. 4.30—Serial Story. 5.0—
Close down.

Early Evening Session: 6.0—Pavilion Dinner Or-
chestra, under direction of Mr. Cec Morrison. 6.30—
Nursery Rhymes and Bedtime Stories. 7.30—Union
Football Talk by Mr. C. L. Brown, editor "N.S.W.
Rugby Union News." 7.45—An address by Mr. T.
S. Tagg, of the Scout Week Committee. Pitt, Son
and Badgery Market and Stock Reports.

Evening Session: 8.0—Mr. Nangle, Superintend-
ent of the Technical College, will lecture on the His-
tory of Architecture. Dance Numbers from the Tro-
cadero Cafe, under the direction of Mr. Jack Lan-
deryou. Mr. William Mason, professional of the
Cammeray Golf Links, will speak on "Golf." Lec-
ture-Concert (Saint Saens). Mr. J. M. Prentice
(lecturer), and Miss Myra Gillon (contralto) singing
"Softly Awakes My Heart," "Fair Spring is Re-
turning," and "O Love, From Thy Power." Miss
Nora Hill (Irish soprano). 11.0—National Anthem.

FRIDAY, 29th MAY.

Early Morning Session: 8.0—News Items. 9.0—
Close down.

Morning Session: 11.0—Social Notes. 11.15—
Music from the Studio. 11.30—Chat on "Modern
Psychology." 12.0—Weather and Commercial Re-
ports, Music from the Studio. 2.0—Close down.

Afternoon Session: 3.0—G.P.O. Clock Chimes.
Music from the Studio. 4.30—Serial Story. 5.0—
Close down.

Early Evening Session: 6.0—Pavilion Dinner Or-
chestra, under direction of Mr. Cec Morrison. 6.30—
Nursery Rhymes and Bedtime Stories. 7.0—Mrs.
Mary W. Liddel, a talk for girls. 7.45—An address
by Mr. Eric N. Birks (Hon. Organiser) on the finan-
cial results of the appeal. Pitt, Son and Badgery
Market and Stock Reports.

Evening Session: 8.0—Vocal and Instrumental
Concert from the Studio, including the following ar-
tists: Miss Myrtle Hobbs (lyric soprano), Mr. P. S.
Templeton (baritone), "The Wind on the Heath"
(Lohr), "Linden Lea" (Vaughan Williams), "When
a Mounting Skylark Sings" (Lohr), "Song of the
Bow" (Florence Aylward). 9.5—Mr. Morgan will
talk on Motoring. Broadcasters' Instrumental Trio.
10.0—Mr. J. M. Prentice, O.C.B., C-de-G, will talk
on "Book Reviews." 11.0—National Anthem.

SATURDAY, 30th MAY.

Early Morning Session: 8.0—News Items. 9.0—
Close down.

Morning Session: 11.0—Social Notes. 11.15—
Music from the Studio. 11.30—Talk on "Health and
Domestic Topics." 12.0—Weather and Commercial
Reports. Music from the Studio. 1.0—Close down.

Afternoon Session: 2.0—G.P.O. Clock Chimes.
Music from the Studio. Special Sporting News. 5.30
—Close down.

Early Evening Session: 6.0—Pavilion Dinner Orchestra, under direction of Mr. Cec Morrison. 6.30—Nursery Rhymes and Bedtime Stories. 7.45—An address by Deputy Camp Chief Macallister on "Scouting Results of the Week."

Evening Session: 8.0—Dance Night. Dungowan Modern Dance Band, Manly, under the direction of Mr. C. J. Little, will play throughout the evening. During the intervals between dances well known artists will be heard. 11.0—National Anthem.

SUNDAY, 31st MAY.

3.30—Vocal and Instrumental Concert from the Studio. 6.45—Service from Palmer Street Presbyterian Church, City. 8.30—Instrumental and Vocal Concert, including Conservatorium Ladies' String Quartet, Miss Florence Yates (contralto).

MONDAY, 1st JUNE.

Early Morning Session: 8.0—News Items. 9.0—Close down.

Morning Session: 11.0—Social Notes. 11.15—Music from the Studio. 11.30—Chat on "A Course in English Literature." 12.0—Weather and Commercial Reports. Music from the Studio. 2.0—Close down.

Afternoon Session: 3.0—G.P.O. Clock Chimes. Mr. Norman Campbell will speak on the Syllabus of Shakespeare. Music from the Studio. 4.30—Serial Story. 5.0—Close down.

Early Evening Session: 6.0—Pavilion Dinner Orchestra, under direction of Mr. Cec Morrison. 6.30—Nursery Rhymes and Bedtime Stories. 7.0—Mrs. Mary W. Liddell, a talk for boys. 7.30—Mr. H. Marks (Sports Master, Sydney Grammar School) talks on School Football. 7.45—Pitt, Son and Badgery Market and Stock Reports.

Evening Session: 8.0—Sydneyans' Jazz Band. Miss Peggy Bell (soprano). Miss Grace Saville (contralto). 11.0—National Anthem.

TUESDAY, 2nd JUNE.

Early Morning Session: 8.0—News Items. 9.0—Close down.

Morning Session: 11.0—Social Notes. 11.15—Music from the Studio. 11.30—Chat on "The World of Art." 12.0—Weather and Commercial Reports. Music from the Studio. 2.0—Close down.

Afternoon Session: 3.0—G.P.O. Clock Chimes. Music from the Studio. 4.30—Serial Story. 5.0—Close down.

Early Evening Session: 6.0—Pavilion Dinner Orchestra, under direction of Mr. Cec Morrison. 6.30—Nursery Rhymes and Bedtime Stories. 7.45—Pitt, Son and Badgery Market and Stock Reports.

Evening Session: 8.0—Operatic Concert.

WEDNESDAY, 3rd JUNE.

Early Morning Session: 8.0—News Items. 9.0—Close down.

Morning Session: 11.0—Social Notes. 11.15—Music from the Studio. 11.30—Chat on "The Musical Outlook." 12.0—Weather and Commercial Reports. Music from the Studio. 2.0—Close down.

Afternoon Session: 3.0—G.P.O. Clock Chimes. Music from the Studio. 4.30—Serial Story. 5.0—Close down.

Early Evening Session: 6.0—Pavilion Dinner Orchestra, under direction of Mr. Cec Morrison. 6.30—Nursery Rhymes and Bedtime Stories. 7.45—Pitt, Son and Badgery Market and Stock Reports.

Evening Session: 8.0—Dance Night.

Murdoch's Valve Set Specials!

Two Valve Assembled Set for £14/10/-

Complete with Valves, Batteries, Headphones and Aerial Equipment.

Three Valve Assembled Set for £17/10/-

Complete with Batteries, Valves, Aerial Equipment and Brown Loud Speaker.

Murdoch's Home Assembly Sets.

Complete with all Component Parts, Blue Print Diagrams and Instructions ready for Assembling.

1 Valve ..	£5/5/-	3 Valve ..	£9/9/-
2 Valve ..	£7/7/-	4 Valve ..	£14/10/-

27/6 Headphones for .. 12/11 pair

Still a few of the well-known "Peerless" Headsets, formerly sold at 27/6, clearing at this remarkable discount.

The New Ormond Square Low Condensers

Supremely efficient in operation.
Guaranteed capacity.

.001	Plain	14/9	with	Vernier	17/6
.0005	Plain	13/-	"	Vernier	15/6
.0003	Plain	12/6	"	Vernier	14/9
	.00025	Plain	12/-		

Murdoch's stock everything in Radio Equipment.

When writing kindly mention "Wireless Weekly."



SET THE **WE** STANDARD

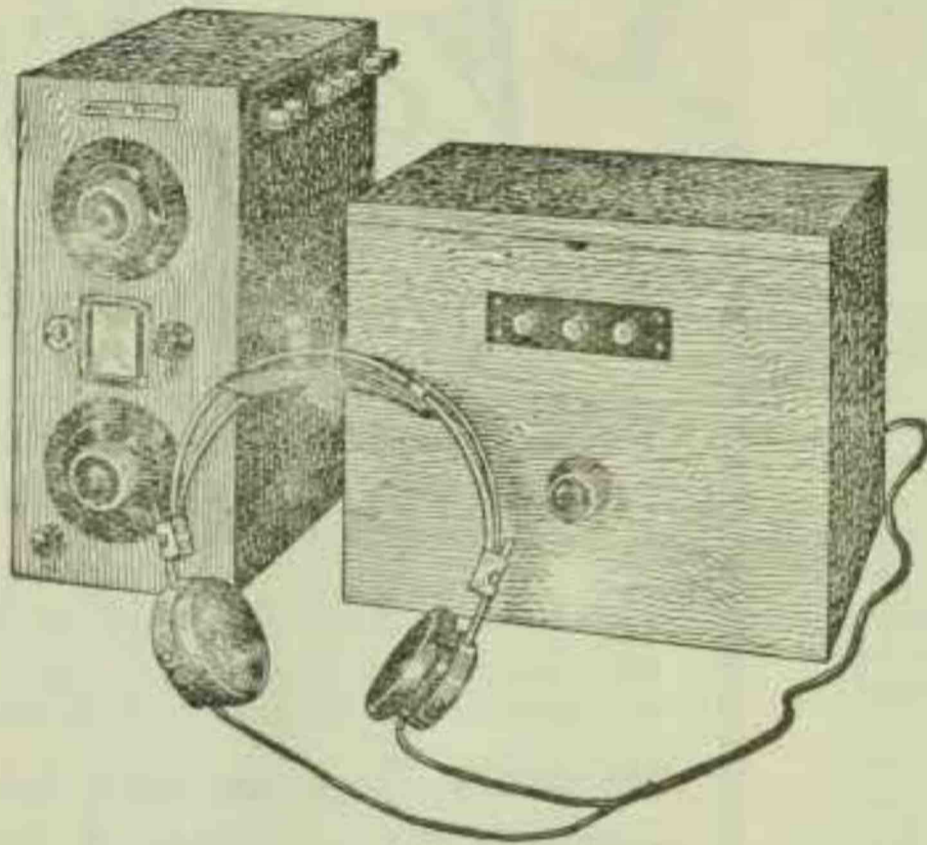

Wonderful value in Western Electric Radio Sets

THE keenest radio enthusiasts are agreed about the uniformly high efficiency of Western Electric apparatus. The latest in Western Electric wireless equipment—WECONOMY Radio Sets—satisfy the same high standard of reliability, yet are cheaper to buy, less expensive to maintain and exceptionally easy to use. Their real value is exemplified by the S.150 WECONOMY 2-Valve High Frequency Set, sold complete with headphones, valves, battery box, and batteries for

£21/-/-

It is operated by dry cell batteries—the inconvenience and expense of re-charging accumulators are done away with. Using head receivers it has a guaranteed range, under normal conditions, of 250 miles.

Where loud speakers are to be operated we recommend Weconomy 4-Valve and 5-Valve Sets. Write for illustrated booklet "Weconomy Radio Sets." If possible call for an instructive demonstration.

Western Electric Company
(Australia) Ltd.

192-4 CASTLEREAGH ST., SYDNEY. Phones: CITY 336, 355 or 356

R. 258

WE

Before you
Expend
Money on
Radio
Equipment
Consult
Anthony
Horderns'
Wireless
Experts.

Your inspection of the big display of everything that is new in the world of Wireless, is invited.

(Wireless -- Second Floor)

Anthony Horderns & Sons
Limited,

Brickfield Hill, Sydney

Phone City 9448.

Box 2712 G.P.O.

CLIX

The Electro Link
with 159 Uses.

TRADE MARK

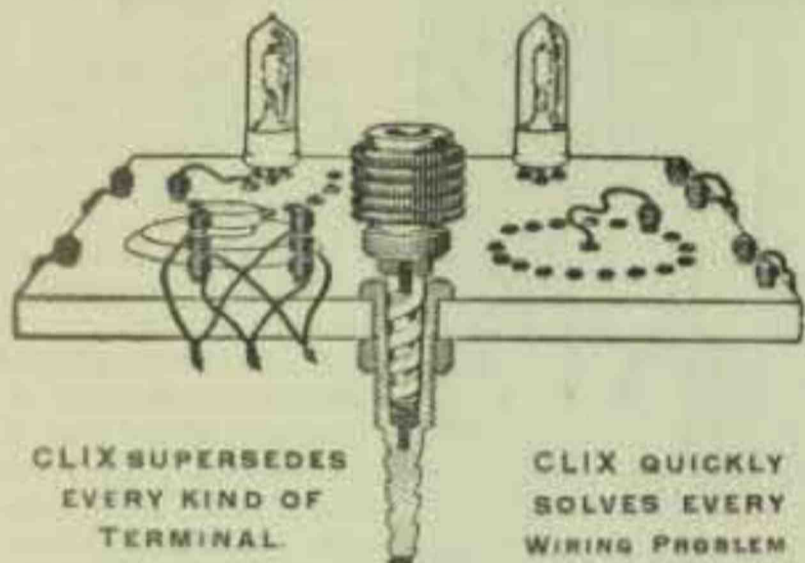

CLIX SUPERSEDES
EVERY KIND OF
TERMINAL

CLIX QUICKLY
SOLVES EVERY
WIRING PROBLEM

CLIX Combination Plug-Socket is the most ingenious and efficient contact ever invented.

CLIX phenomenal and world-wide sales are convincing proof of their popularity and merit.

CLIX Illustrated Leaflet describes many applications

CLIX are patented all over the world.

Write for list to-day—Few Agencies still available.

AUTOVEYORS LTD.

RADIO ENGINEERS, CONTRACTORS & EXPORTERS

82-84 VICTORIA-ST., WESTMINSTER, LONDON

Telegrams: Autover,
Sowest, London.

Trade Terms on
Application

RADIO RADIO

Wireless Dealers Only Supplied.

Our new 120 page Illustrated List of Radio Parts now ready, Showing Trade and Retail Prices. Copy sent on application.

COMPLETE SETS AND COMPONENT PARTS.

We were one of the very first Wholesale Factors of Radio, and to-day hold the largest stocks of Wireless Goods in the British Empire.

Staggering Prices — Huge Stocks — Get to Know Us — It will Pay you.

Wireless Traders order from us. We have a large Export Department, and know how to deal with your Indents. To prevent delay goods can be ordered through London Merchants or if ordering direct should be accompanied by 25 per cent. deposit, balance at Sight-Draft.

Buy from an Established House.

Please Note——— Wholesale Only

HOBDAV BROS. LTD. (Dept. T)

21, 23, 25 and 27 Great Eastern Street
LONDON, E.C.2

Cables: "Yadboh," Finsquare, London.
A.B.C. 6th Edition.

Columbia 45 Volt

Vertical "B" Battery No. 4772



DESIGNED for all sets having not more than four tubes using 90 volts. Occupies less than half the table space of the horizontal 45 volt battery, yet contains the same large, powerful cells. Three Fahnestock spring clips—negative, plus 22½, and plus 45 volts.

Use only

Columbia Radio Batteries

Made by the manufacturers of the Famous Columbia Dry Cell

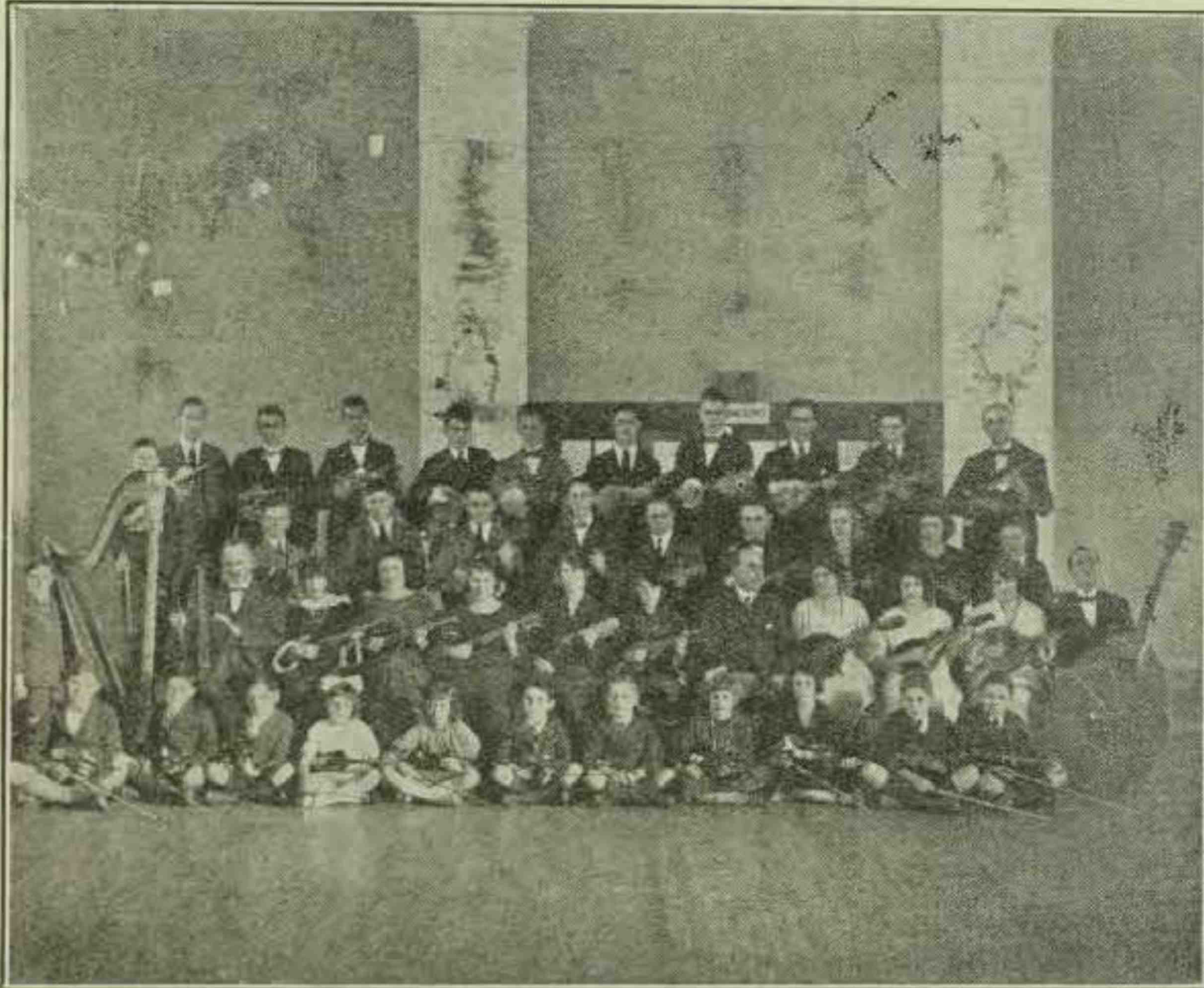

KING'S STRING ORCHESTRA.

KING'S ORCHESTRA, BONDI.

This orchestra has a membership of sixty, and has full string instrumentation — violins, cellos, mandolins, mandolas, mandocellos, bass, organ, harp, and tympani. The record of the members has been one of steady progress under the direction of Mr. Chas. King during the past three years, until they have, as this gentleman genially remarked, reached the stage where they can "go the full twenty rounds" with the classics and standard overtures, and will shortly have the pleasure of presenting the Schubert "Unfinished Symphony" on the air.

King's Orchestra will shortly be on the air via station 2UW.

Clarence King, the youngest member of the organisation, is the youngest harpist in the world, being only nine years of age, and his skillful and artistic manipulation of the large Erard harp in this orchestra is a very strong feature.

WILL JAMES AND HIS FAMOUS CASINO ORCHESTRA.

Will James' Orchestra is well known to thousands who delight in the good music dispensed at the Bondi Casino. The members of the orchestra are all professionals, and Mr. James has been many years associated with theatrical enterprises. Mr. Albert S. Bennett is manager of the Casino. 2UW will shortly be putting the Casino Orchestra on the air.



ACCURACY!

Accurate Results are Impossible With Inaccurate Instruments

THERE can be no question that the accuracy of the instruments used is responsible to a great extent for the success or failure of your experiments. When in transmitting or receiving, correct voltage or amperage information is of utmost importance. Efficient and economical operation is impossible without it.

The name Weston on an instrument means that there is none better; cheaper instruments are obtainable, but if you value results you cannot afford anything but the best.

FILAMENT VOLTMETER.

Model 301 Weston Voltmeter costs more than a tube, but it is invaluable because it saves many tubes from burning out prematurely. With a Weston Voltmeter you can always duplicate instantly any voltage required—and exact tuning is thereafter a simple matter. For quick tuning and good reception, it is an absolute necessity. Case diameter 3 1/4 inches.

ANTENNAE AMMETER.

Specially designed to measure antennae current. It eliminates all troubles encountered in hot wire types—has no zero shift, and is thoroughly compensated against changes in temperature. It is the adopted standard in commercial and government work. Flange diameter, 3 1/4 inches.

THERMO-GALVANOMETER.

The Model 425 is a sensitive thermo-milliammeter of low resistance for use in connection with wavemeters. It measures wave length and decrement. Instrument resistance about 4.5 ohms requires 115 milliamperes for full scale deflection. Flange diameter, 3 1/4 inches.

SOLD BY LEADING RADIO DEALERS.

Booklet "J" describes and illustrates these various Weston Instruments. Everyone interested in Radio should send for this important data. If your dealer cannot supply you with Weston Instruments, we will gladly see that your needs are promptly supplied.

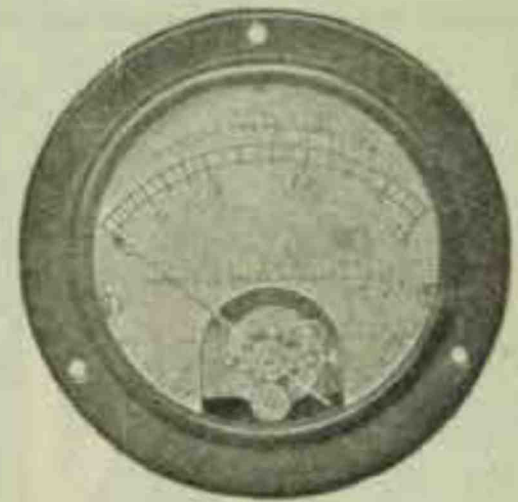

THERMO-AMMETER

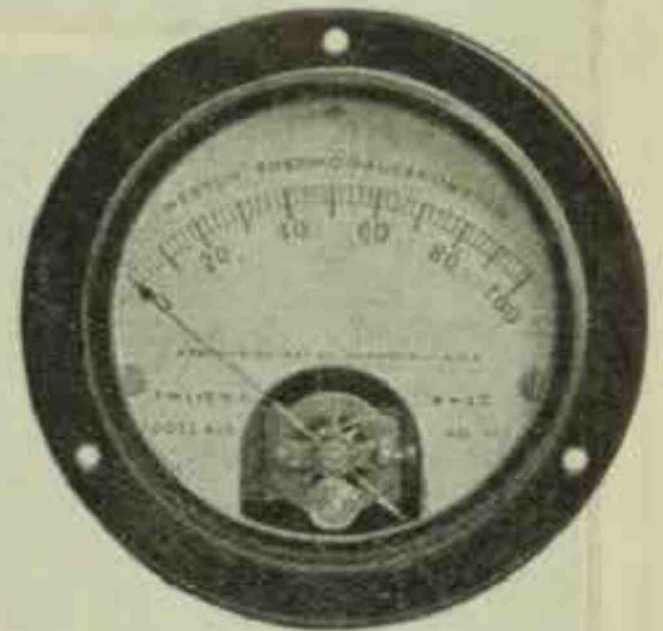

THERMO-GALVANOMETER

SALES REPRESENTATIVES:

WARBURTON, FRANKI, LTD.

307.11 KENT ST., SYDNEY.

Tels. BW1251 BW1252 BW1253

WESTON
"STANDARD" THE WORLD OVER.
ELECTRICAL INSTRUMENTS
An Indicating Instrument for Every Individual Need and Industrial Purpose



*Ask your
Dealer for it!*

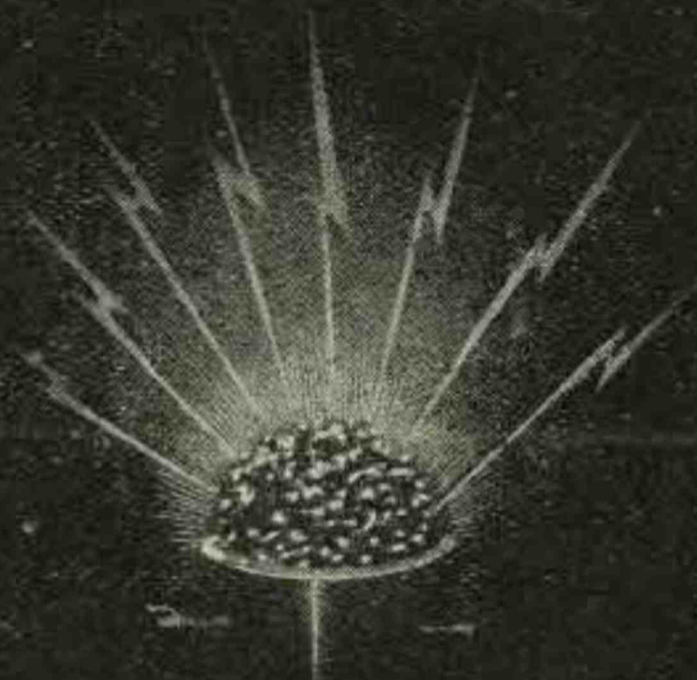

NEUTRON

TRADE MARK

The World's Greatest Radio Crystal

*Concert tested
and Guaranteed*

Paroso Ltd. 113, Gawler Place, Adelaide

*A Product of
Neutron Ltd, Sicilian House,
Southampton Row, London W.C.1*

THE
“MACLURCAN”

LOW LOSS RECEIVER

Complete with Valves and Coils

£16

Calibrated and tested by Mr. Chas. MacLurcan, and exactly similar to the set used by him for receiving English and American Amateurs.

Wavelength range, 40-385 metres.

Supplied with Valves, 6 Interchangeable Coils, and Calibration Chart.

A super set. Call and let us demonstrate, or write for full particulars to

RADIOELECTRIC

Wireless Suppliers, Wireless Engineers,

10 MARTIN PLACE,

right opp. G.P.O.,

SYDNEY, N.S.W.

Phone: B 2666.

Noyes Bros. (Sydney) Ltd.

and

Noyes Bros. (Melbourne) Pty. Ltd.

Have pleasure in announcing that, as from May 15th, they are to act as sole concessionaires in Australia for the world-famous Radio Parts manufactured by IGRANIC ELECTRIC COMPANY LTD. of London and Bedford.

They also are sole selling agents for the renowned Head Telephones, Loud Speakers, Microphone Amplifiers, etc., of S. G. BROWN LTD., of London, and are distributors of PHILIPS RADIO VALVES, the perfect valve for perfect reception.

LARGE STOCKS HELD

SUPPLIES — SERVICE — SATISFACTION

Snifter Specials for Saving Souls !!!

Phillips Valves D.1, 11, IV, & V	11/9
Phillips Valves B.2. Dull Emitters	17/6
Radiotron 201a Bakelite Base (new)	20/-
Radiotron U.V.199 Bakelite Base (new)	20/-
De-Forrest D.V.3 Valves	21/-
Jefferson Type 4/1 Transformers	24/-
Modern 4/1 American Transformers	23/-
Jefferson "Star"	19/-
Bucks English Transformers	12/-
Repeater Phones, 4,000 ohms	20/-
Amplion Speaker "Dragon" A.R.19	145/--
Amplion Music Master "A.R.15"	164/-
Amplion "Dragon-fly" A.R.102	35/-

Service Station open from 6 a.m. to 8 p.m. week days and from 6 a.m. to 1 p.m. and 4.30 p.m. to 8 p.m. on Saturdays.

Accumulators are charged on the premises, a quick service at 1/6.

Same day service for Country Clients—no long waiting for your goods.

PRICE'S RADIO DEN

220 Oxford Street, WOOLLAHRA

Phone Wav. 451



For Effective
Low Wave Length Reception

THE HETERODYNE WAVE METER

Complete with—
Calibration Charts
& Dry Cell Valve—

£12/12/-

David Jones' have specially designed a Heterodyne Wavemeter to simplify long distance reception on low wave lengths. The wave length of any station received may be recorded easily for future reference and the receiver set for any station in a few seconds.

The wavelength range is from 50 to 1800 metres, covering all amateurs and all English, American and Australian Broadcasting Stations. This is the first time in Australia that a general purpose wave-meter has been offered to the public, complete with calibration Charts and dry cell Valve for the remarkable price of £12/12/-. Calibrations accurately made by F. Basil Cook, F.R.A.S. Manager of David Jones' Radio Service.

Write or call for further particulars.

DAVID JONES'

For Radio Service.

22 YORK STREET, SYDNEY.

Broadcast Brevities

PRINCE EDWARD THEATRE.

The transmission from the Prince Edward Theatre the week before last on the occasion of the 300th performance of "The Ten Commandments" was, as usual, a mechanical and musical treat. It is to be hoped that 2FC will be able to arrange further transmissions of the wonderful orchestra and organ effects from the theatre.

ELECTIONS.

On the eve of the elections it has been thought interesting to include in 2FC Talks short addresses on "Proportional Representation." Two well known authorities on this subject have been approached, namely, Mr. A. G. Huie and Mr. S. V. Larkin. Mr. Huie's talk was given on Saturday, 23rd May, at 7.45 p.m., and Mr. Larkin's talk will be given on Thursday, 28th May, at the same time.

SUNDAY MORNING SERVICES.

Applications are being received from so many churches for the broadcasting of their services that 2FC, who are at present handling transmissions from six different churches, will arrange to take morning services. Further particulars will be announced.

GOLF TALKS.

The first of the Golf Talks, arranged by 2FC, commenced on Wednesday, 27th May, with the first of a series prepared by Mr. F. S. Shenstone, of the Bonny Doone Golf Club. The subject was "Principal Differences Between Match and Stroke Play." These talks will be carried on, and will be made still more interesting by the inclusion of matter from a well known professional. It is proposed to describe the actual play in the Golf Championships commencing shortly.

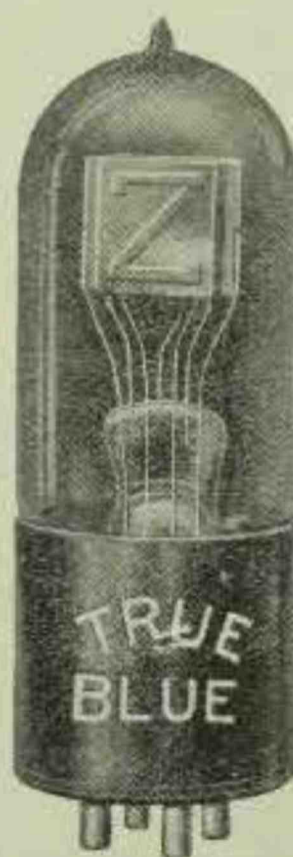

EXIT
"Ordinary Valves"
ENTER
"Non-Microphonic Tubes"

The Wonderful
"TRUE BLUES"

Increased demand and production have enabled these "Wonder Tubes" to be reduced to 31/6, bringing perfect music by Wireless within the reach of all.

Obtainable at Good Radio Stores

Sole Agents for Australasia:

Parsons & Whittemore Ltd.
30 Market St., Sydney

BARGAINS

Large Genuine Reductions

To make room for New Stocks.
Come and inspect, or write for
☛ **BARGAIN LIST** ☛

COLVILLE-MOORE
Wireless Supplies Limited
10 ROWE STREET, SYDNEY

PHILMORE

RADIO APPARATUS

		Retail.
Contact Points, with Hex Nuts, unassembled	... per doz.	6d.
Switch Stops, with Hex Nuts, unassembled "	6d.
Binding Posts, Nickel-plated, unassembled "	2/-
Insulated Knob Binding Posts, assembled "	3/9
Initialled Binding Posts (8 on a card) card	3/-
Brass Hexagon Nuts, 6/32 per doz.	3d.
Sliders, Brass, 1/4 in. each	1/-
Antenna Insulators "	1/-
Switch Levers "	1/3
Inductance Switch "	5/6
Insulated Dials, 2in. "	1/9
Insulated Dials, 3in. "	2/-
V. T. Sockets, moulded "	2/6
V. T. Sockets, metal shell "	3/-
U.V. 199 Sockets "	2/9
Rheostats, mounted base, 6 ohm "	3/-
Rheostats, mounted base, 30 ohm "	4/-
Potentiometer, mounted base, 240 ohm "	4/9
Potentiometer, mounted base, 400 ohm "	5/-
Glass Enclosed Detector, unassembled "	3/-
Crystal Detector, Open Type, unmounted "	1/3

FROM ALL DEALERS.

PACIFIC ELECTRIC CO. LTD.

87 CLARENCE STREET, SYDNEY

Phone B 5891

Sole Australian Distributors

Sensitivity and Distance

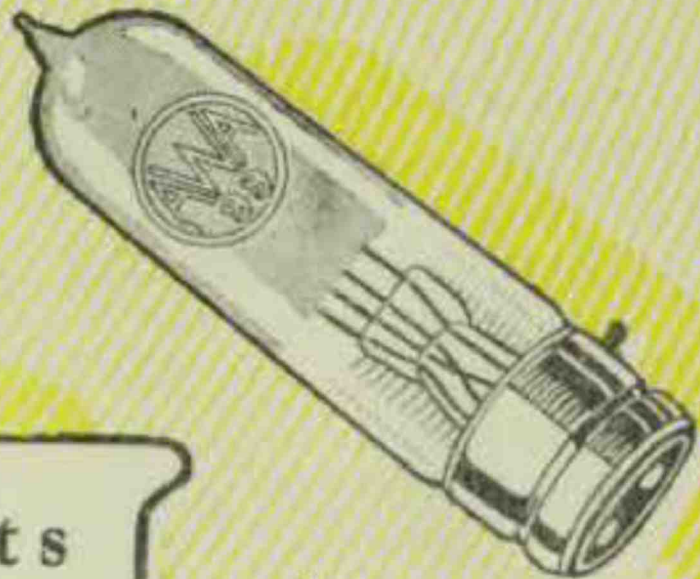
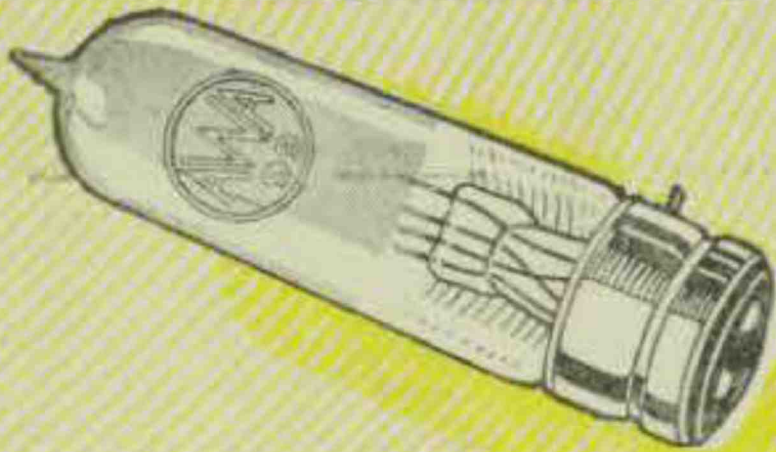

Exceptional Results
are being obtained with the

AWA 99

It is a low consumption dull emitter valve operating with a filament current of only 0.06 of an ampere. Dry cells may thus be used for the filament lighting. The filament is of thoriated tungsten, differing from the older type of tungsten filament in that the power consumption and operating temperature are much lower ensuring longer life.

The electrostatic capacities between the electrodes are very small, consequently the valve is an exceptionally good radio frequency amplifier. It likewise functions well as an audio frequency amplifier and as a detector. The AWA 99 can be relied upon to give uniform and quiet operation throughout its life.

PRICE 22/6

Amalgamated  Wireless
(Australasia) Ltd.

97 Clarence St., Sydney.

Collins House, Collins St., Melbourne.

AWA 99

EH

An L.F. Power Amplifier



GECovalve, Type DE5.

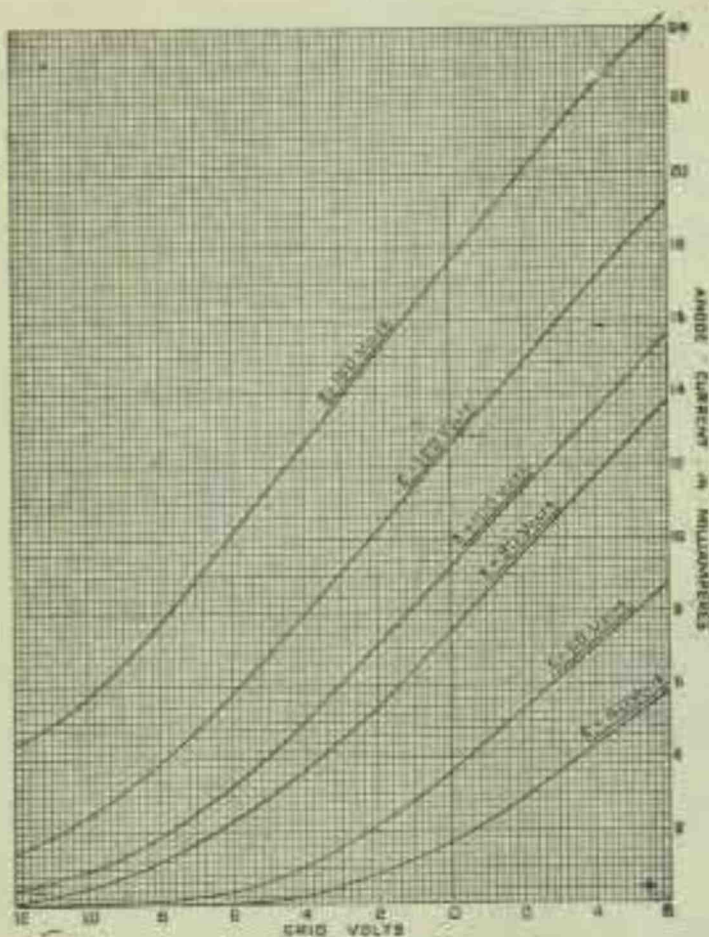

Characteristic Curve Chart.

GECovalve DE5 was designed for the listener-in using one or more stages of low frequency amplification, and who wants the maximum loud-speaker volume with the minimum of distortion.

The DE5 is primarily a low frequency power amplifier and has the economical filament consumption of .25 amps.

GECovalve DE5 CAN BE SUPPLIED WITH EITHER ENGLISH OR AMERICAN STANDARD BASES, NOW!

The DE5 is particularly recommended as the last stage of an amplifier using R5V or other valves in the preceding stages running from a 6 volt accumulator.

CHARACTERISTICS*	PLATE VOLTAGES.
Filament Voltage 5	Detector 30-40 v.
Filament Current .25 amps.	Radio Amplifier 40 v.
Plate Voltage 30-150	Audio Amplifier 120 v.
Impedance 7,000 ohms	
Amplification Factor 7	

GECovalves are made at the Osram Lamp Works, England, the largest of its kind in the British Empire.

Their manufacture is directed from the Research Laboratories of the General Electric Co. Ltd., by valve experts who are also experts in the design of wireless sets.

There is a specific type of GECovalve for every purpose.

GECovalve DE5 : Price 30/-

Obtainable from all Reliable Wireless Dealers
British General Electric Co. Ltd.

154 Clarence Street, Sydney
 and at Melbourne, Perth, Adelaide, Newcastle.

Gecovalve DE5