

WIRELESS WEEKLY

Registered at the G.P.O., Sydney, for

transmission by post as a newspaper.

VOL. 5. No. 26.

FRIDAY, APRIL 24, 1925.



All the Time!

PHILCO users are reminded that an up-to-date Service Station exists for their benefit at the premises of the Distributors—New System Telephones Pty. Ltd., 280 Castlereagh St., Sydney, Phone: M 3230. The Technical attention which has contributed so much to the success of PHILCO Products is always to be had and PHILCO users are well advised to avail themselves of it's benefits.



PHILCO
DYNAMIC RADIO
BATTERIES

REIN. ALL WIRE
NOTES

FEATURE:

A Tetrode
Receiver

CLARITY · VOLUME · DISTANCE

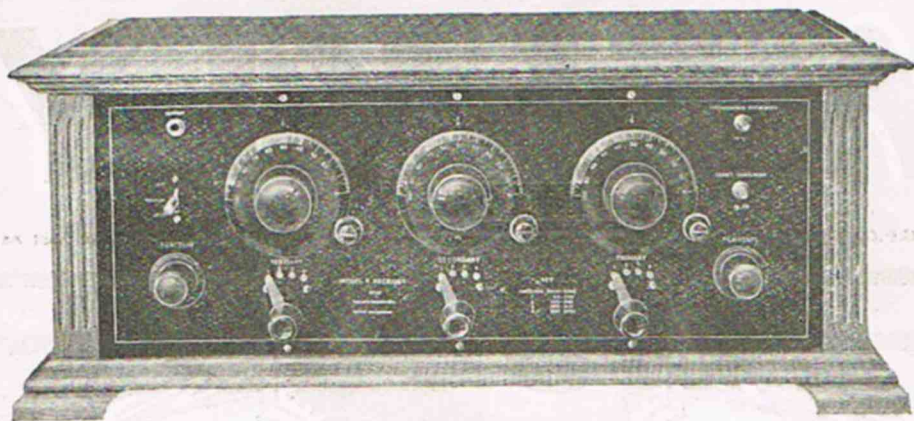

Radio Luxury U.D.L. Radio Receivers

HERE at last is the home receiving set, complete in every detail, guaranteed to receive all Australian "A" class Broadcasting stations.

So simple—anyone can operate it.

So efficient—distance without distortion, no loose coils; wave length changed by a simple switch adjustment.

Absolutely complete—including batteries, headphones, and aerial equipment.

So handsome—in place in the best furnished homes.

U.D.L. models L and K are undoubtedly the greatest achievement in home radio in Australia to-day. "United" radio engineers have spent several years in evolving suitable circuits, which have been patented throughout Australia.

U.D.L. MODEL K.

(5 valves).
Complete in every detail,
and adjusted to cover a wave
length band of 60 to 2,000

metres, in a handsome full
French polished maple or ash
cabinet. £50 0 0
(Without access-
ories) 38 10 0

If not at your Dealer's write direct to

United Distributors Limited

(Wholesale Only)

72 Clarence St., Sydney
592 Bourke St., Melbourne
Queen Street, Perth.
Cr. Jervois Quay & Harris Street, Wellington.

Use Clyde Storage Batteries for Radio, Motor Car, and Home.

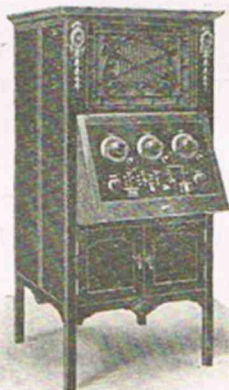

THE BEARD DE LUXE.

as illustrated, and including
loud speaker, all accessories,
and erection by United Dis-
tributors Radio Engineers.

Price 100 guineas.

U.D.L. MODEL L.

(4 Valves.)

With same circuit as model
K described above £40 0 0
(Without access-
ories) 28 10 0

Cullen's Circuit No. 6

"YOU HAVE MY WORD FOR IT."

ONE often hears it remarked that broadcast reception is an excellent form of entertainment but for the distortion in reproduction, which spoils whole programmes. This need not necessarily be. The circuit shown below is one that will totally eliminate this annoyance. It is a P1, with two stages of audio frequency amplification. Instead of the usual transformer method of coupling, resistances, that are not particularly critical, are employed. In the circuit they are marked as 50,000 ohms, but 100,000 ohms are quite satisfactory. The fixed condensers in the grid leak need only be .006. H "B" Battery of 120 volts is required to give the necessary strength, and often the grid bias assumes the pretensions of 9 to 12 volts. The volume that results from three valves coupled in this manner is certainly not quite so great as with transformer coupling, but the sweetness and clarity of reception is unexcelled by any other circuit. This is a circuit suitable for all wavelengths.

In actual use Phillips B11 Miniwatt Valves functioned admirably, as did True Blues and UV201a's. The coils to be used are as advised in "Wireless Weekly" from time to time.

The following materials are advised:—

1 Bakelite Panel, 14 x 6½ x ½	7/6
1 2-Coil Holder (De Luxe, Un-assembled)	9/6
1 .001 Master Condenser, with Dial	1/7/6
2 100,000 ohm Resistances	3/-
2 2-meg. Grid Leak	3/-
1 Bradleyohm (10)	13/9
2 .006 Wetless Condensers	7/6
1 .00025 Wetless Condenser	1/6
1 .0005 Wetless Condenser	1/6
2 Valve Sockets (Nutmeg)	10/6
3 Nutmeg Rheos., with Dials	1/-/-
10 Terminals	3/4
Panel Wire, etc.	2/-

A Distortionless Circuit with Valve Rectifier

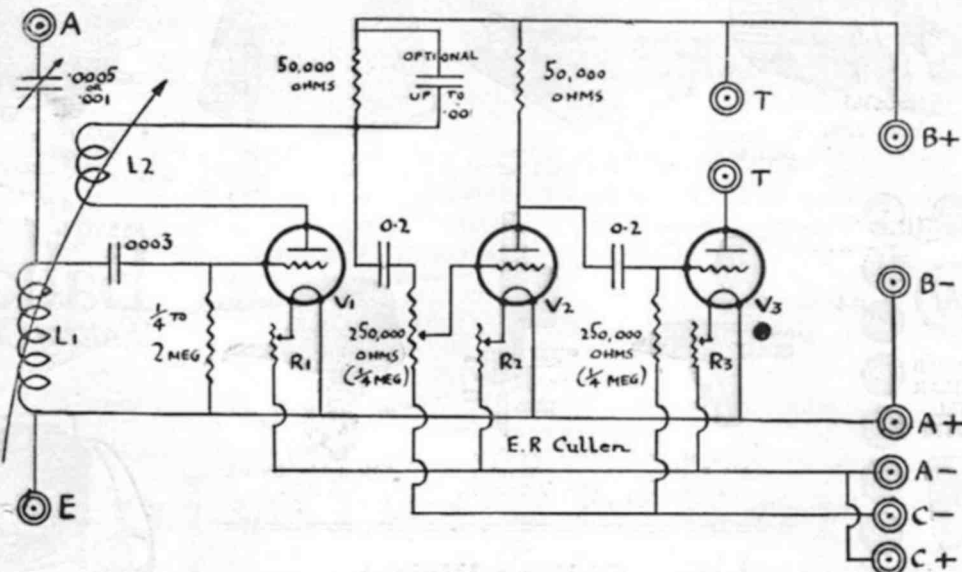

E. R. CULLEN,

RADIO & ELECTRICAL STORE
:: 96 BATHURST STREET ::

Telephone City 804 & 2580

WALNART

MAKER OF
Good Goods Only

World's Greatest Buy!
Everyone Knows It!
Sales Prove It!
Service Sells It!

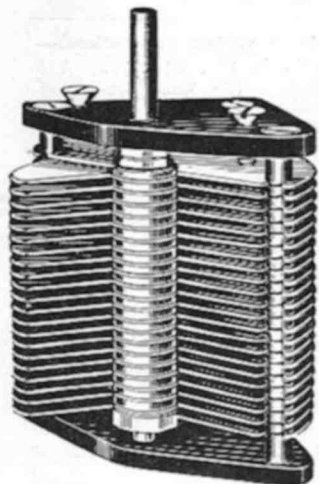

PLAIN TYPE CONDENSER.

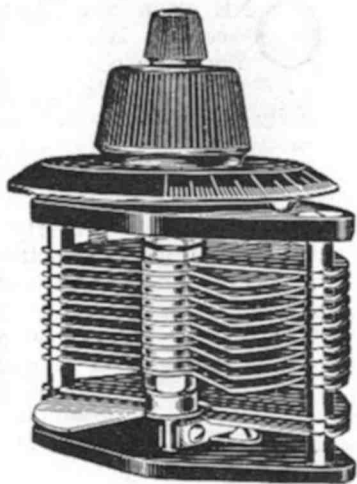

VERNIER TYPE CONDENSER.

It is your guarantee or reliable apparatus, dependable service, and "Trouble Proof" Products

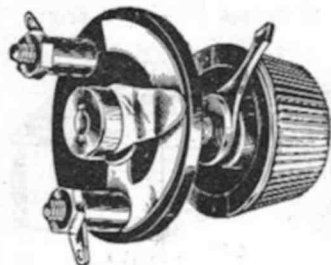

Variable Grid Resistance, zero to six megohms.

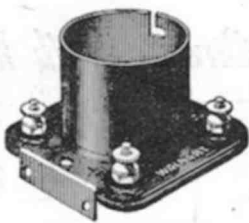

Standard Sockets (Nickel & Oxidised).



Moulded Knobs (all sizes).

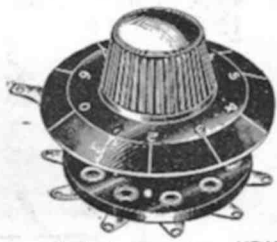

Inductance or "B" Battery Switch, with or without Dial.

- ANT
- TEL
- AB
- GND
- ABAT
- 8BAT
- ABAT
- 8BAT
- CBAT
- 90 VOLT
- SLOTTED COLLAR TEL POSTS
- CBAT
- 45 VOLT
- DET
- 22 VOLT
- AMP

Plain and Lettered Binding Posts.



Filament or "A" Battery Switch.

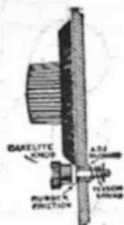

Friction Vernier Adjusters.



Adjustable Switch Lever.

FANSTEEL
Balkite
Battery Charger

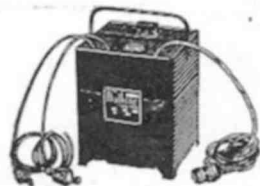

Call or Write:
Commonwealth Radio Co.

Phone: M A 1626

200 CASTLEREAGH ST., SYDNEY

5th FLOOR



The Next Step in WIRELESS

Will You be Ready for It ?



"The Next Step in Wireless" is the title of the editorial in a recent issue of the Sydney "Sun." The question is asked, "How much do we owe to amateurs?" The writer then says that most of the advance in the knowledge and technique of Wireless in Australia is due to patient young men who have made Wireless their hobby.

Are you a Wireless amateur? Is Radio your hobby? If it isn't, you're missing some of the greatest pleasure and education that this great achievement makes possible.

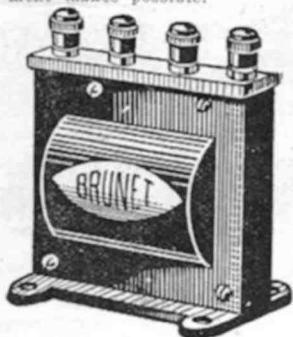

Brunet Transformers

Brunet Transformers assure correct amplification without distortion, and completely eliminate whistles, squeals, and all unpleasant sounds.

Their function is to help reproduce a song as it was sung; a violin or any other instrument, exactly as it was played; a speech, as it was spoken; and so on. That is, of course, as it should be, and, to ensure this result, you must ask for Brunet Transformers, ratio 5 to 1.

They are shielded type to protect against external stray currents, and are fitted with low-loss coils and ebonized knobs on terminals.

PRICE EVERYWHERE, 21/-.

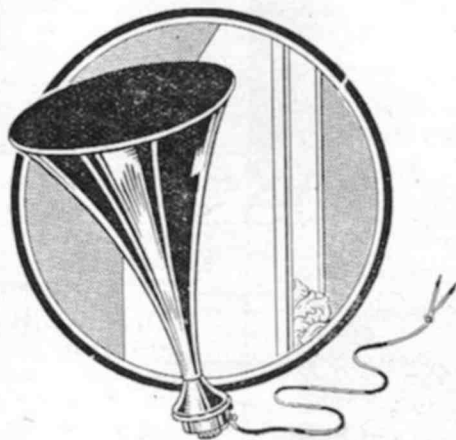

Baby Brunet at 32/6

World's Best Value in LOUD SPEAKERS

Baby Brunet Loud Speaker will appeal—first of all, because it makes the entertainment available to everybody; secondly, because it gives all the results that could possibly be desired in a room; and thirdly, because the price is little, if any more, in excess of the cost of a pair of reputable headphones. Baby Brunet Loud Speaker is complete with attachments and flex, and is ready to use immediately. Repose it on any flat surface, connect to your Set, and the fun starts.

The price at all Retailers... 32/6

Apart altogether from what will be the next step in the technical or scientific development of Radio, everybody should be more keenly alive to the subject with the approach of Winter. If you have a Set already, YOUR NEXT STEP should be to improve it to ensure the best results during Winter—the best Radio season. If you have no Set, then get one. That's a step that will soon convert you, too, into an enthusiastic Radio Fan.



Honeycomb Coils

Tunawave Coils are the kind that help you "tune in" quickly, at the same time guaranteeing maximum results and satisfaction.

25 Turns	2/-
35 Turns	2/2
50 Turns	2/4
75 Turns	2/6
100 Turns	2/9
125 Turns	3/-
150 Turns	3/3
200 Turns	3/6
250 Turns	3/9
300 Turns	4/3

HONEYCOMB COIL MOUNTS

1/6 each.

CORBETT DERHAM & CO. PTY., LTD.

231 CLARENCE STREET, SYDNEY.

MELBOURNE, SYDNEY, BRISBANE, ADELAIDE, LONDON, NEW YORK, CHICAGO.

REPRESENTATIVE FOR QUEENSLAND: WALTER F. DENBY, 80 EAGLE ST., BRISBANE.

Igranic Representative from England

NOYES BROS. (SYDNEY) LTD., and Noyes Bros. (Melbourne) Pty., Ltd., announce that they are taking over the exclusive selling in Australia of the wireless component parts manufactured by the Igranic Electric Co., Ltd., of London and Bedford, which company Noyes Brothers have represented in Australia for many years in connection with their electric control apparatus. In addition to the "Igranic" wireless parts, Noyes Brothers are sole agents for head phones, loud speakers, etc., manufactured by S. G. Brown, Ltd., of London, and are distributors of "Phillips" radio valves and rectifiers. Large stocks of these lines will be carried for the convenience of the trade.

In order to secure the benefit of the latest English experience, the Igranic Electric Co. have sent their Mr. P. H. Pettyfer to join the staff of Noyes Brothers. Mr. Pettyfer, who arrived in Sydney recently, is a well known radio engineer, and has had several years' experience of the Igranic Company's manufactures.



Mr. P. H. Pettyfer.

The American Tests

The Burgin Electric Co., Ltd., of 340 Kent Street Sydney, report that on Thursday evening station WOR, operating on a wavelength of 405 metres (this wavelength was checked by this company's instruments), was received clearly and distinctly at 9.25 p.m., when an item of mixed voices rendering "Sweet and Low" was received. At 9.33 an announcement that "the next item will be a flute solo" was heard, together with the actual item, on a standard "Burginphone" 4-valve instrument which operated a loud speaker and was heard distinctly all over the room. 9.40: Item, "Waters of Minnetonka." 9.45: Male

voice rendering a humorous song. 9.50: Violin solo, "Raff's Cavatina." 10.0: "God Save the King" (orchestra). Then the final announcement was made—"Good-night, everybody; good-night."

This reception was carried out by Mr. W. H. Morey, chief assistant, technical staff of the Burgin Electric Co., Ltd., at his house, 51 Rangers' Avenue, Cremorne.

This instrument is of Australian manufacture, and is designed and built entirely in the factory of this company in Sydney. When it is considered that this instrument was not specially made for these tests, but is of the standard type and embraces all wavelengths of the broadcasting stations of Australia, which covers the widest band of broadcasting wavelengths possibly in the world, certainly must be credited as being a very meritorious performance.

THE LITTLE STATION WITH THE BIG KICK.

Here is the programme for next Sunday evening (April 26) from Broadcasting Station 2UW:—
7—7.30: Bedtime Stories by Uncle Otto.
7.30—10: Evening Programme.

Mr. Harold Bennett (tenor)—

(a) "Songs of Araby."

(b) "Love Sends a Little Gift of Roses."

Miss Jean Kennelly (soprano)—

(a) "Love's Cigarette" (by request).

(b) Selection from "Pipes of Pan."

Miss Rita French (piano), two fox-trots —

(a) "Dancin' Dan."

(b) "Chile Bom Bom."

Miss Dorothy Durant (soprano)—

(a) "Dream of Home."

(b) "April Morn."

Miss Herford (violin)—

(a) and (b) to be announced.

Mr. Harold Bennett (tenor)—

"I Heard You Go By."

Miss Bellamy and Miss Rita French, pianoforte duet—

"Poet and Peasant."

Miss Jean Kennelly (soprano)—

"Love Is My Life."

Miss Dorothy Durant (soprano) and Miss Gilda

Hae (soprano), duet—

"The Barcarolle."

Mr. George Dalton (tenor)—

(a) "Shores of Minnetonka."

(b) "Dream, Daddy."

Miss Dorothy Durant (soprano)—

(a) "I Hear a Thrush at Eve."

(b) "Sing, Joyous Bird."

Miss Rita French (piano)—

Popular dance numbers will be announced.

Special Note.

On Saturday, April 25th (Anzac Day), a musical programme will be broadcasted from 11.30 a.m., concluding at exactly 12 noon with "The Last Post."

We have pleasure in Announcing the arrival of
Fresh Stocks of

ACME LOW LOSS Condensers

AT ALL **48/6** GOOD STORES

JUST ARRIVED

"BLACK BEAUTY" SPEAKERS

These Speakers are offered with the conviction that they
are BETTER VALUE than any other Loud Speaker
Regardless of Price

Everywhere **75/-** Everywhere

WE HAVE JUST OPENED UP STOCKS OF

E. T. Flewelling Low Loss Condensers

MADE BY THE
FOREMOST LOW
LOSS AUTHORITY

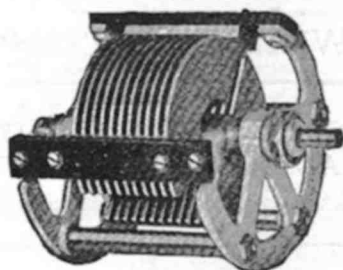

IN THE
UNITED
STATES

Have you entered for the "SCIENTIFIC" HEADSET COMPETITION YET?

DEFINITELY CLOSES APRIL 18th, 1925

Wholesale
Only

P. H. CLARK LTD.

Phone: City 8469
Box 914, G.P.O

38-44 CARRINGTON ST., SYDNEY

Our Agents in other States:

VICTORIA: W. N. Bartholomew, 380/382 Flinders Lane, Melbourne.

QUEENSLAND: Colin Campbell, "City" Buildings, Edward St., Brisbane.

SOUTH AUSTRALIA: Cedric Wright & Co., "Hayward" Buildings, Charles St., Adelaide.

ACME ——— WALNART ——— HILCO ——— LINCOLN LOOPS, Etc.

Marconi Transmitters for Gunboats

The Siamese Government has recognised the advantages of a ship that is carrying out coastal duties being equipped with wireless telephony apparatus, and has given instructions to Marconi's Wireless Telegraph Co., Ltd., to instal a 1.5 kW. transmitting apparatus in a river gunboat being built for them

by Messrs. Armstrong, Whitworth and Co. The set will be a Marconi type "U" valve transmitter, having a range of approximately 300 miles for telephony and 800 for telegraphic work. These figures will, of course, vary in accordance with local conditions, but it is anticipated that the vessel will be able to get into communication with outlying towns, aerodromes, and ship's stations, and will be of considerable value to those in authority.

Introducing The VOLMAX Low Loss SET

This wonderful little set is the ideal shortwave low loss work. It consists of

DETECTOR AND ONE STEP

and utilises

TETRODE (Double Grid) VALVES

WITH ONLY 8 VOLTS HIGH TENSION, ENSURING SILENT
OPERATION AND EXTREME DISTANCE.

THESE SETS WILL BRING IN AMERICAN STATIONS.

Price : without accessories £18

Phone:

M3378

Wireless Supplies Limited
21 ROYAL ARCADE - SYDNEY

Phone:

M 3378

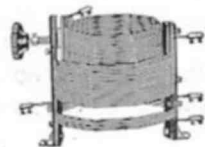

"Grodan"

Low Loss Coupler.
19/6 each.

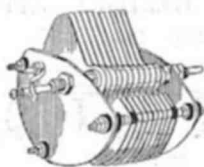

"Grodan"

Low Loss Condenser.
.00025, 16/6.
.0005, 21/-.



"Grodan"
Spider Web Plug in Formers.
Most Economical Appliance on the Market. Suitable for all Circuits. Can be wound up to 400 Turns. City Price, 1/3 each. Pins, 9d. pair.



Wire Connector
Clips. No Kit complete without "Grodan" Clips.

1/6 packets.

Wholesale from

GROSE & DANIELL, 185a George St. West, Sydney

Wireless Weekly

12-16 REGENT STREET, SYDNEY, AUSTRALIA.

'Phones: Redfern 964 and 930.

Official Organ of the New South Wales Division of the Wireless Institute of Australia, with which are incorporated the Affiliated Radio Societies and the Australian Radio Relay League.

Editor: A. W. Watt.—The Editor will be glad to consider Technical and Topical Articles of interest to Australian Experimenters. All Manuscripts and Illustrations are sent at the author's risk, and although the greatest care will be taken to return unsuitable matter (if accompanied by stamps), the Editor cannot accept responsibility for its safe return.

"Wireless Weekly" is fully protected by copyright, and nothing that appears in it may be reprinted, wholly or in part, without special permission. The use of our articles or quotations from them for any purpose whatsoever is never authorised.

VOL. 5 No. 26

APRIL 24, 1925

Editorial.

Concerning Aerials

A TOUR of the suburbs of Sydney and of the main roads for forty or fifty miles north, west, and south convinces one that broadcasting is popular with the multitudes, for one sees the familiar aerials slung from various supports—some good aerials, some fair, and some decidedly bad.

For some reason or other, practically every individual seems to cherish his own particular idea of just what an aerial should be, and it is to be feared that many have entirely sacrificed efficiency for the sake of appearance or to save the exertion of putting up something decent. This fact should be realised by everybody—that the aerial is a most important factor and merits special attention. Merely to suspend a metal conductor in mid-air is not sufficient—its length is important, as are also one or two other factors which should be considered.

A four-wire cage aerial may be attractive, but unless, of course, one has a transmitter it is very often more of a hindrance than a help to good reception, for several reasons. The dominant one is that every foot of metal there is in the aerial, the greater will be the surface exposed to atmospheric. With the ordinary valve receiver, a one-wire aerial is just as efficient as two wires or more. A single wire just about 80 feet long, including the lead-in, is about the ideal, and will ensure that atmospheric

interference is cut to a minimum, instead of being accentuated through the use of a lot of totally unnecessary wire.

Up to the present the problem of the elimination of static has not been overcome, but it is possible to lead only a minimum of it into the receiver. Aerials strung parallel to and fairly close to power lines very often give rise to objectionable and puzzling noises in the phones, so that it is always advisable to take this factor into consideration when erecting an aerial, even though the scenic effect has to be sacrificed. It is also a good point to remember that an aerial may be made slightly directional, and so, if practicable, it should be put up so that it points towards the broadcast station which it is desired to receive more often.

The efficiency of an aerial also depends upon as perfect insulation as it is possible to instal, and it is not good practice to haul the wire up and leave it there for years without further attention. Fine dust and soot settle on the insulators, and in the course of time become caked, permitting an imperfect, though serious, conduction from aerial to earth. Though the power at the broadcasting station may be five kilowatts, only a small portion of the original energy reaches the distant aerial. If the wire is lowered occasionally and the insulators thoroughly cleaned, the listener at least ensures that almost the full amount collected by the aerial reaches the receiver.

Jamming the window-sill down upon a flex lead-in is asking for trouble, because on damp nights there is almost certain to be a leakage from the wire to the window-ledge, and in any case there is always the possibility of breaking the wire, leaving no visible sign of the damage, on account of the cotton insulation. A proper lead-in tube is cheap, looks better, and makes an efficient job.

Last, but not least, a lightning-arrester is a necessity; it is not only required by the underwriters, but affords a protection for the receiver during a storm, unless, of course, the aerial is earthed.

All these little points may seem ancient, but it is really surprising how little attention they get, and how seldom it is realised that good reception is not only governed by good receivers, but also by a good aerial.

Where there's Wireless—There's Wireless Weekly

HEADQUARTERS
Royal Society's House
5 Elizabeth St.
SYDNEY, N.S.W.

Wireless Institute of Australia

N.S.W. Div. Inc.

Incorporating the Affiliated Societies and The Australian Radio Relay League



Phil. Renshaw, Hon. Sec.
Box 3120 G.P.O. Sydney
Phone B2235
A.H. Perrett, Publicity Officer.

NEW SOUTH WALES DIVISION. ANNUAL GENERAL MEETING.

THE annual general meeting of the Wireless Institute of Australia, New South Wales Division, was held at the Royal Society's Hall, 5 Elizabeth Street, Sydney, on Thursday, April 16, 1925.

Two new members were unanimously elected, and this division certainly feels stronger by the addition to its roll of Messrs. R. C. Allsopp and J. W. M. Cottrell. The outstanding feature of the evening was the presidential report. Mr. MacLurean gave a very interesting and detailed account of the work of the Institute during the past twelve months, but it would not be fitting if reference were not first made to Mr. MacLurean's latest success in communicating with England on low wave lengths during daylight hours. Congratulations of members were offered to Mr. MacLurean, and were of a most enthusiastic nature.

Mr. MacLurean then read the presidential report, which was as follows:—

Again we have concluded a most satisfactory year for this division of the Institute, and we commence the year 1925-26 with confidence in our ability to make an even better showing than we have done in the past twelve months.

It has been a great pleasure to me to work with such a fine team of officers as it has been my good fortune to be associated with in the past twelve months, and it is my earnest hope that whoever are elected to control the coming year's destinies will preserve the happy concord that has existed throughout in the last period.

The class of new members being attracted to our Institute is one of the most pleasing features, and we confidently expect a very substantial membership increase this coming year.

We have now on our roll 80 members and 29 associate members, making a total of 109.

Elections during the year comprised 24 members and 8 associate members.

Resignations during the year totalled 21, including 11 members and 10 associate members.

It may be argued that the resignations are very numerous, and indicate a falling off in the strength of the Institute.

On the contrary, it will be remembered that the year 1922 was a period of grave moment to this division; in fact, it almost ceased to exist. This was due to a misguided policy. The position then created caused a positive revision of this division's policy, with the result that the subscriptions were increased and the standard of membership raised to fairly high plane. When the Institute became registered there were many who were accepted as foundation members by virtue of their membership in the former unregistered Institute who did not possess the qualifications demanded by the articles of association. It was a foregone conclusion that time alone would weed out many of these members, and this, added to the increased subscription rates, has expedited a matter which otherwise might have taken many years to achieve. We are now in the fortunate position of knowing that all our members are really keen on the progress of the Institute, and, further, that their interest is backed by their financial stability as members and associate members of the division. It will thus be seen that the next body of officers controlling this Institute should have a most happy period of office.

This leads me to discuss the financial position of our Institute, upon which all its activities are based. The hon. treasurer in his report discloses a very satisfactory financial position, and it will be noted that outstanding subscriptions have been reduced to a very low figure, indeed, due to the activity and keenness of your executive officers. In this connection I would like to refer to expenditure in a general way. One of our biggest items of expenditure is rent for our headquarters office, which is £75 per annum, and includes the use of the Royal Society's Hall once per month for our general meetings, also lighting is included. The typiste's salary amounts to £104 per annum; this is the best investment this Institute ever made. Miss Howard has shown un-

ceasing devotion to her duties, and always has a smile whatever the emergency. Before leaving this subject I desire to make a suggestion concerning proper control of finances during forthcoming years. I consider a budget should be drawn up by the incoming council outlining proposed expenditure, and allotting definite amounts for the different departments of the Institute's activities and controlling the expenditure as far as possible within the limits of the budget.

Now to consider the research aspect of the past twelve months. By no means can we be said to have accomplished all we desired and set out to do at the beginning of the year. Obstacle after obstacle has had to be met, and the biggest obstacle of the lot has been to properly organise the research bureau of the Institute. It is of such paramount importance that it is unfair that such work should fall on the shoulders of the hon. secretary, who is much more than fully occupied with the everyday activities of the Institute, and I venture to say few of our members and associate members realise how large the hon. secretary's department has become. With the affiliated clubs and the Australian Radio Relay League now directed from the Institute's headquarters, and the enormous ramifications of our correspondence section, the business side of the Institute has tended to outweigh the research side, and it will be one of the first duties of the new council to see that the research now comes in for its proper share of attention. I say this without reflecting on the retiring council in any way, as, if they were continuing in office, they would now grasp this problem fairly and carry out the projects proposed, most of the groundwork of which they have already constructed. While on the subject of research I might draw attention to a report being made by the Relay League committee to the delegates' council, which is meeting to-morrow night, in which it is recommended that the activities of the research bureau and the league be combined into one section, to be known as the Experimental Research and Traffic Bureau of the Wireless Institute. In the next fortnight this scheme will no doubt have to be considered by the new executive council, and the suggestions will merit careful consideration, they being sound and planned to meet the future developments of radio research in this country.

The inauguration of the Institute's standard frequency transmissions, which have been conducted by Mr. H. A. Stowe from his station, 2CX, is a step of vital importance, and must not be allowed to wane. In fact, there again the load falls on the willing horse, and in fairness this division should possess its own transmitting and receiving apparatus at headquarters, where responsible officers could con-

duct these transmissions in rotation, thus evening up the work.

Supervision must be of the most strict nature, and must at the same time be in harmony with the members empowered to operate such apparatus. There are other avenues of research receiving attention at present, and I hope next year's presidential report will be full of the research activities of this division. We possess the members with the necessary qualifications for this work, and we are, indeed, fortunate in this regard.

The affiliation of the radio clubs to this Institute is a step which is now commencing to bear fruit. Much good work has already resulted from this movement, and it bids fair to exceed the highest expectations of the Institute. The delegates' council has met consistently, and the attendances have been most satisfactory, and the nature of the business conducted proves how important this affiliation movement has become. So great has the stimulation of the club movement become that clubs are engaged in much friendly rivalry and have arranged a scheme of contest to be conducted perpetually for a trophy. I make no excuse for having donated the MacLurcan Cup to stimulate this movement, and feel that the measure of support so far evinced points to much good arising from the various inter-club activities. The institution of the affiliated clubs' lecture roster under the direction of Messrs. Cutts and Carter has been a pronounced success so far as it has gone, and I plead for much attention being given to this important development, and that it be kept up to concert pitch all the time.

One of the most interesting developments of the past period is the inauguration of the lunch hour committees every Monday and Thursday, when as many councillors as possible meet at headquarters and discuss current events whilst at lunch. This has freed the regular council meetings from much work which would otherwise have to have been held over for them. Then, again, every lunch hour as many members and associates as possible foregather at Institute headquarters for a chat. The effect of all this is a great improvement in the social side of the Institute, as thus the members all become well acquainted, and discuss all their problems freely and secure advice and assistance from each other's experiences. I say to all members and associates make use of your headquarters as much as possible. Meet each other there and discuss your difficulties, where you can receive attentive and sincere interest. The reference library is alongside, and will also play an important part in assisting you.

Members individually are proving their importance in the experimental field. During the past

twelve months regular low power communication with U.S.A. has been achieved on C.W., and on the eve of this meeting a report is received that an experimenter, whose application for membership we are now considering, has maintained telephony communication two ways with U.S.A. on less than 100 watts. Then we have seen communication on low power with England, France, Finland, and, in fact, all the world established as a regular thing.

There have also been developments of different types and units of apparatus which you are all more or less acquainted with, and which I sincerely hope will continue, and that you will all inspire each other to even greater successes in the future.

We must not lose sight of the tremendous development which has taken place in broadcasting in this country, and much credit is due to the pioneer broadcasting companies and to the radio traders generally for their conscientiously having "delivered the goods" to the best of their ability, and I venture to say the radio business in this country is the cleanest of any in the world.

The development of Marconi's beam is likely to place us in immediate commercial radio communication with the whole world, particularly with Canada and England, and who cannot praise the loyal enterprise of Amalgamated Wireless Ltd. in shouldering their full share of the burden and the risks entailed? It is such enterprise that makes a nation, and we are proud to number E. T. Fisk, Esq., the managing director of Amalgamated Wireless, amongst our members who have achieved and are achieving much success for the benefit of the nation.

In a different sphere we number Mr. G. A. Taylor, president of the Association for the Development of Wireless in Australia, New Zealand, and Fiji, amongst our members. His patriotism is undoubted, and having just returned from Europe he is conversant with the huge radio progress being made in the old world.

Our country members are a great asset, and it should be the programme of the incoming council to see that they be given every possible encouragement, as they are living in the great outback where communications are slow and tedious, and they can become a vital force for the inauguration of radio inland communication, which will tremendously benefit Australia's primary producers and the primary industries in which they are engaged. I say that this Institute must take up the cudgels to improve inland communication, and radio is the method to adopt. It is storm-proof, white ant-proof, fire-proof, and—best of all—cheap.

I must refer to the generous treatment we have received during the past twelve months from Mr. J. Malone, chief manager of telegraphs and wireless,

Melbourne, and Mr. W. T. S. Crawford as radio officer in Sydney. They have shown the utmost tact and skill in administering a most difficult department, and it stands to their credit that radio is in the position it is to-day in Australia. Much credit is also due to Mr. Brown, secretary to the Postmaster General, in his efficient handling of many difficult situations and his consideration for the experimental activities of this country.

Our associated divisions in all the other States of Australia are working in complete harmony one with another and with this division, and much credit must be given to our hon. secretary for the successful conclusion of most difficult situations which existed in Queensland and Tasmania. His personal activities in both these areas must be commended. We do not forget that he spent his last holidays visiting Brisbane, to straighten out the tangle which had arisen there. It is unselfish devotion to the Institute which counts, and I trust you will all unite in the one endeavour and, being happy, make others happy. After all, it is not "what do we get out of the Institute" that we should look for so much, but we must realise that the more we put into the Institute the more it will return to us.

In conclusion, I commend one thought to you all. You have become keenly interested in wireless and radio research. Now consider your steps carefully as you proceed, and weigh all your actions so that the best possible legacy may be left to those who will eventually take your places in the development of this wonderful science; and, above all, subdue any jealousies of another's achievements, and remember, "Honour unto whom honour is due."

Sincerely yours,

CHAS. MACLURCAN,

President.

Mr. Malcolm Perry, in moving the adoption of the presidential report, drew attention to the fact that this division of the Institute was the first Radio Society in the world, being formed three years before the Wireless Society of London. He paid great tribute to the exploits of 2CM, stating amidst great enthusiasm that Mr. MacLurean leads the entire world in experimental radio work.

This motion was seconded by Mr. Mingay, who also spoke in eulogistic terms of Mr. MacLurean's work.

The motion was also supported by Mr. H. A. Stowe, who stated that the way in which the foundation of the Institute was built was an excellent one, and there was no doubt that the Institute would progress even more rapidly in the future than it had done in the past.

Mr. G. A. Taylor also spoke to the motion. He

(Continued on Page 38)

BANK UPT STOCK

Books on Radio.

Bakelite

Battery Testers, from 4/6

Condensers, from 4/6

Coil Mounts (2), from 5/6

Coil Mounts (3), from 9/-

Crystals, from 6d.

Crystal Detectors, from 2/-

Coils, from 1/6

Dials, from 1/6

Electric Irons, from 18/6

Electric Kettles, from 35/-

Electric Radiators, from 59/6

Jacks, from 2/-

Leaks, from 3/-

Loud Speakers, from 60/-

Lightning Arresters, from 3/-

Potentiometers, from 4/3

Plugs, from 2/-

Rheostats, from 1/6

Rotors, Ebonite, from 2/9

Switches, DPDT, from 3/6

Soldering Sets, from 1/6

Sockets, from 1/6

Terminals, from 2d.

Tools, Clips, Best, from 2/3

Tools, Snips, Best, from 2/9

Torches, Electric, from 2/9

Telephones, from 17/-

Transformers, from 15/6

Wood Baseboards & Crystal Parts

from 6d.

Valves, all makes, from 9/6

Crystal Sets, from 14/6

Also:

201A Valves.

Walnut Condensers.

Baldwin Headsets.

Bradleystats.

Frost Lines.

Signal Condensers.

Our Speciality Headphones, 17/-

EDWARD FAHEY & COMPANY

2nd Floor, 88 Pitt St., Sydney

A TETRODE RECEIVER

By "INSULATOR."

REALLY I don't know if the heading of this article should not be the "Unidyne Receiver," but my previous experience with a receiver employing a four electrode valve was by no means pleasant. On that occasion I built a two valve receiver, detector and one audio, but this time my attempt is confined to one valve. I have devoted quite a considerable time to getting the best from a tetrode valve, and have met with varying success. Many circuits worked, but none of them ever came up to the standard of the P1, consequently I couldn't see the justification of recommending that which was to me obviously inferior as far as valve sets go. Yet I was always troubled; I couldn't quite see why such a large firm as Philips would produce and place on the market a four electrode valve if there was no excellent use it could be put to. I think I have found the excellent use—in fact, I am sure I have, so I am passing it on for the benefit of "Wireless Weekly" readers.

In saying I have found the excellent use is, in fact, not quite correct, as I am indebted to Mr. Young, of Glebe, for the circuit produced herewith. He, I understand, "dug" it up from a French publication, and the claims made for it there were such that he built it, and he was so pleased that he passed it on to me.

I have since learned that this circuit is very much in evidence on the Continent, and really it deserves to be. Sweetness is the keynote, no extraneous noises whatever being present in reception. In

fact, when mine was being tried out the silence of the receiver was quite awesome. The "healthy" signs so prominent in the average set were not apparent, and I began to doubt the correctness of my work until I tuned into Farmer's. That left no doubt in any way, as the volume was quite satisfactory for a single valve set, and the reproduction was really wonderful. This was, indeed, pleasing to me, as I, in common with most other good experimenters, am always anxious to improve the quality of reception. Last week's amplifier is a step in this direction, and this week's single valver is another.

Those who are interested go to and build it from the following particulars. First of all the following parts are necessary:—

- 1 Bakelite panel, 10 x 7 x $\frac{1}{2}$.
- 1 Bakelite sub-panel, 6 $\frac{1}{2}$ x 3 $\frac{1}{2}$ x $\frac{1}{4}$.
- 1 .001 or .0005 variable condenser.
- 1 Fixed panel plug.
- 1 Movable coupling plug.
- 1 Bradleyohm 25.
- 1 Vernier rheostat (30 ohms).
- 1 English valve socket.
- 4 N.P. terminals.
- 8 Ebonite top terminals.
- 1 Baseboard, 9 $\frac{1}{2}$ x 5 x $\frac{1}{2}$.
- 1 .00025 grid leak and condenser.
- 12 feet square bus bar.
- 1 Philips B6 valve.

It will be noticed that a vernier rheostat is specified. This is, practically speaking, imperative, as I found. Originally I had just the ordinary rheostat in the set, but, noticing how critical the adjustment was, I had recourse to substitute a vernier. Had one been available at home I should certainly have fitted Bradleystat or a Marshallstat for finer adjustment still. Another feature noticeable is that the tuning is very sharp; critical, in fact. As a result I had recourse to fit a vernier condenser to assist matters.

The panel layout is very simple, indeed. It will be noticed that the condenser and rheostat are on the same level, and immediately above the rheostat is located the Bradleyohm 25. This resistance, by the way, varies from 25,000 to 250,000 ohms, but is not quite critical, although its presence will be felt. The sub-panel may require a little explanation. Mounted there will be found the valve socket and the battery terminals.

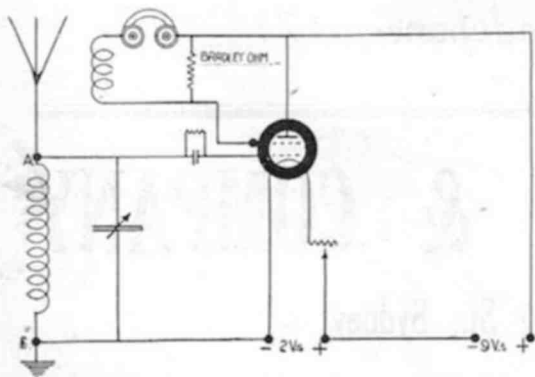

The Circuit.

WATCH FOR THE SOUTHERN CROSS.

To ensure satisfactory mounting of the English sockets I have mounted four ordinary nickel-plated terminals on the sub-panel and taken the connecting wires from the socket pins to these terminals. This simplifies wiring. You would be well advised to do likewise. The illustration will show you just how mine appears. The grid and both filament leads are wired on the surface, but the plate lead is kept underneath. Drill the required holes for accommodating these parts and mount as shown. Before screwing down to the baseboard finish the

Soldering often presents great difficulty to the average person, so a little word on this matter won't be out of place. First of all a clean iron is essential. To clean the bolt, heat it in the gas or fire and file four smooth surfaces on the V parts, and while still very hot tin the iron. Some spirits of salts should be poured into a shallow tin lid, and a few small pieces of soft solder should be placed in it. The hot iron should be rubbed in this lid until a nice bright surface is obtained on all faces. See that

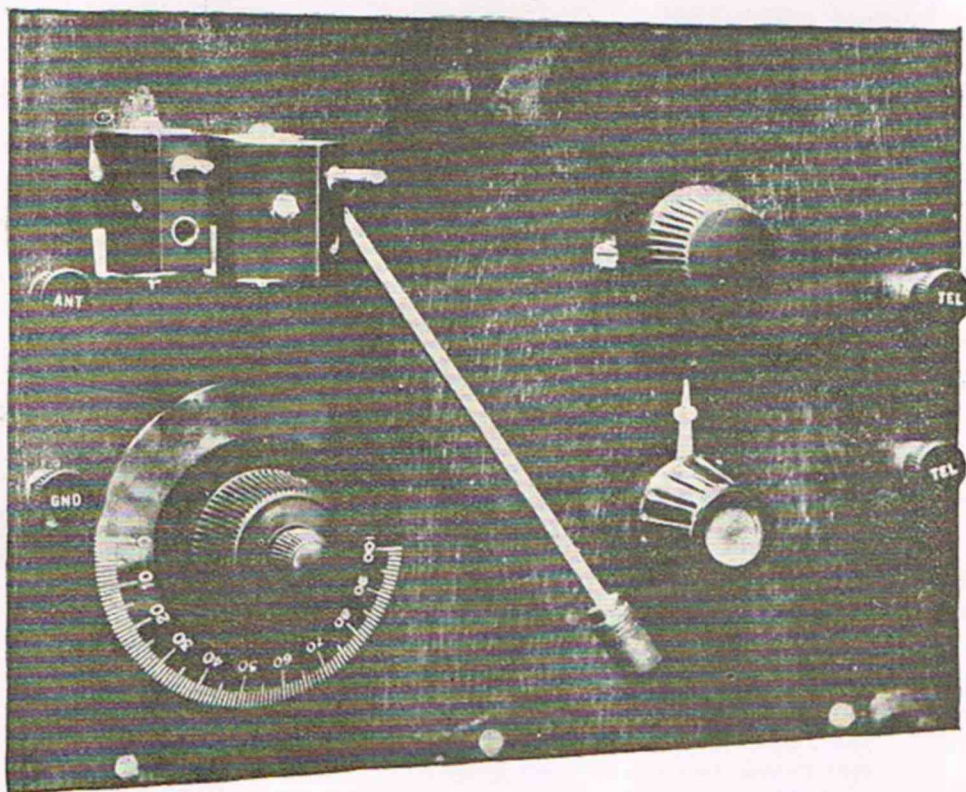

Front Panel View.

necessary wiring on the sub-panel. The circuit will help you in this. Confine your attention now to the main panel. I haven't given you a panel layout diagram this week, as I am sure a little initiative displayed by you will dispense with the necessity for such a thing in this simply-made set.

Assemble all your materials. Now proceed to wire-up. That square bus bar is to be recommended for this purpose, as it is nice and easy to work. When connecting from a terminal make neat little eyelets with a pair of round nosed pliers.

the bolt is quite hot, otherwise the tinning will be difficult to obtain.

In actual soldering, a small piece of flux should be wiped on the prospective joint, and the iron on which a blob of solder is picked up should be applied to the flux wiped parts. The iron should be held there until the solder runs well into the joint. Allow it to cool, and your joint will be perfect. This is not an attempt at "soldering without tears," as this is not possible for quite a long while as a rule. Practice is the greatest aid. Back to our set!

Complete the wiring by taking the final connection from the Bradleyohm to the grid screw on the side of the valve. Now hook up ready for listening in. Use two No. 6 Columbia dry cells for the A battery and two No. 1000 Ever-ready torch refills for the plate battery. Slip on your phones, light the filament, and with suitable coils for 2BL (35 and 50, say) or 2FC (150 and 150) listen in. Turn your

this receiver will be found as good as the average P1 single valve. It is certainly more selective, and should solve a problem for quite a number of people.

Funny! When I tested my set on the aerial I listened in for 2BL. Not a sound could I get. Reference to the programme showed that 2BL was transmitting. The circuit was checked over and everything found to be O.K. Many sad thoughts

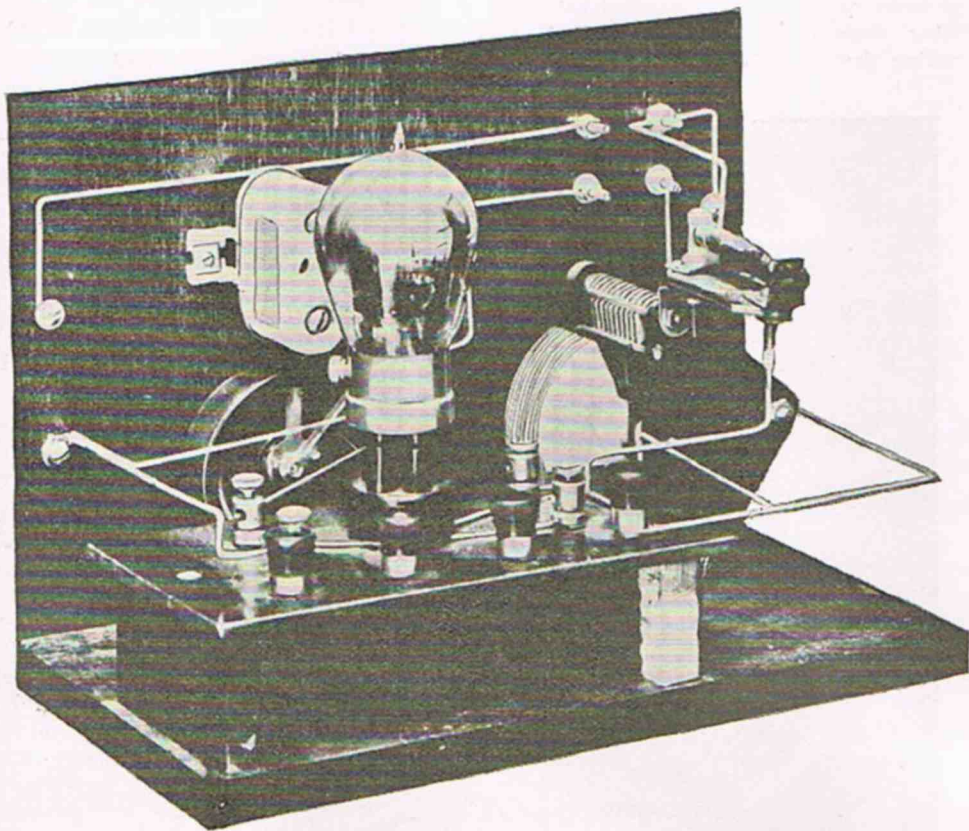

Back Panel View.

condenser round slowly until you hear the station. Handle the filament rheostat carefully, as this adjustment is surprisingly critical. Now attend to the Bradleyohm. Play with this in conjunction with the coupling of the reaction coil, as one is related to the other. You will find that when properly understood

permeated my mind until I hooked up the old crystal set, which also yielded no results. Huge sighs of relief displaced the sad thoughts, as 2BL had struck a little trouble and was not on the air. Let me wish you better luck on your try-out.

Where there's Wireless there's Wireless Weekly

TUNING

By E. Joseph

EVERY owner of a radio set, be it a simple slide tuner or a more ambitious multi-valve set, is familiar with the process of "tuning." Very few, however, are acquainted with the meaning of the word, and with the real reasons underlying the process. Why does a few degrees in some cases only a fraction of a degree, movement of a dial make "all the difference"? Why do signals rise from zero to a maximum and die away again to zero as the dial is turned? I can, in imagination, hear some explaining resonance. What do they mean by resonance? Bringing circuits into "tune," of course.

Tuning is bringing circuits into resonance and resonance is bringing them into tune. This explains nothing.

Let us delve a little deeper into the subject. In a previous article I explained and attempted to illustrate by means of mechanical analogies what an oscillation is and to indicate some of the properties—not all—of oscillating circuits. Those who read and intelligently digest the explanations given, must have noticed how the spring and the weight, the capacity and the inductance, seemed to work together against the resistance or friction and yet to work against each other in retaining the energy. If I apply to the spring a force or pull of constant strength, the spring extends rapidly at first, and then more and more slowly, until finally it comes to rest when the reaction equals the applied pull. If I apply to a mass a force or pull, the mass moves slowly at first, and then more and more rapidly until finally it moves at a uniform velocity when friction absorbs energy as fast as I supply it. If I apply to a condenser a constant voltage the condenser commences to become charged rapidly at first, and then more and more slowly, until finally all charging current ceases when the capacity exerts a back pressure equal to that of the supply. If I apply to an inductance, a constant voltage, a current flows—weak at first, and then stronger and stronger until finally it reaches a limiting value imposed by the resistance. If these pulls or voltages cease before the final stage is reached, or if the pull or voltage alternates in direction, then the condenser may never become fully charged, the current though the inductance may never reach the limit imposed by the resistance. The more rapid

the more marked is the effect. It is as if there is an additional resisting force or an increased amount of friction which we have not yet considered. This apparent resistance does not absorb energy. It stores it up and delivers it again as and when needed. To differentiate between frictional or energy absorbing resistance, and energy storing resistance, we use a new name for the latter—we call it reactance, calling that due to a condenser capacity reactance, and that due to an inductance inductive reactance. Both resistance and reactance are measured in ohms, but while broadly speaking, resistance is quite independent of frequency and is the same for steady direct current as for alternating, reactance is directly dependent upon frequency.

The reactance of a condenser is infinite for a steady direct current and has a finite value for alternating current, which value falls as the frequency rises. The reactance of an inductance is zero for steady direct current, and has a value which rises with the frequency for alternating current. The circuits with which we are concerned in radio, have resistance capacity reactance, and inductive reactance. The resistance of any conductor may be calculated from a knowledge of its length, area of cross section and the material from which it is made and is—contrary to an opinion formed by most students of the subject—absolutely constant apart from heating effects, at all times and for direct or alternating current.

The term high frequency resistance, is unfortunate; the resistance is no higher than it would be for the same conducting path on direct currents.

The capacity of a condenser and the inductance of a coil may be calculated with a fair degree of accuracy from a knowledge of their geometrical conformation and of the physical properties of the material outside them, but surrounding the conducting parts. Resistance, capacity and inductance may be measured by a number of different methods. The reactances of the two latter may be measured or calculated. The calculation may be made for any frequency, but it is very difficult to measure them at high or radio frequency, owing to the fact that measuring instruments for use at high frequencies have not yet been brought to a sufficiently high degree of

development. Before proceeding, notice that the reactances of a condenser and an inductance, act in opposite directions. The one falls as the other rises. The art of tuning is to so adjust these reactances that at the desired frequency they annul each other. Any alteration of frequency will destroy their equality, necessitating a further adjustment. The effect of tuning on the currents and voltages depends to a great extent upon the arrangements of the circuits.

is the voltage which exists between the junctions of coil and condenser A and B in the diagram.

Columns 8, 9 and 10 are of impedance, current, and voltage, assuming the coil has a resistance of 1 ohm. only, and 11, 12 and 13, assuming the resistance to be 30 ohms.

I have plotted 3 curves showing how the current varies with the dial setting by using for curve 1, columns 1 and 6, for curve 2, columns 1 and 9, and for curve 3, columns 1 and 12. From

1	2	3	4	5	6	7	8	9	10	11	12	13	14	15	16
SCALE	C	X _r	X	Z	A	V	Z	A	V	Z	A	V	Z	A	V
READ	mfd	ohm	ohm	ohm R=3	mull. amp	volts	R=1			R=30			R=0		
50	00025	437	135	135	7.4	3.7				138	7	5.5			
55	000275	426	12	12	12.2	6.1				123	11.5	5.8			
60	0003	531	29	29.1	16.5	12.2	29	55	17.5	4.2	24	1.2			
62	00031	515	11	11.4	17.7	44	110.5	91	45.5	5.2	31	15.5			
63	00035	505	3	4.25	25.5	11.7	3.2	31.6	15.8	50.1	33.2	14.4	3	350	4.5
63.3	000311	502	0	3	550	16.5	1	500	250	50	55.5	14.66	0	∞	∞
66	00052	497	5	5.8	17.2	16	5.1	194	98	30.4	32.9	4.4	5	200	100
65	00032.5	490	12	12.4	10.1	60	12.06	85	41.5	32.3	31	15.5			
70	00045	455	6.7	6.7	21	10.5				52	1.8	9			
80	0006	398	10.6	10.6	9.4	6.1				108	9	6.3			

To illustrate these effects without calculation is a somewhat difficult matter, and it will be necessary for the reader who does not care for the small amount of mathematics used to take certain facts as granted correct. I propose to consider a circuit consisting of a 35 turn coil shunted by a .0005 mfd variable condenser, fitted with a 100 division dial. Such a combination could be used to tune in a 300 metre wave or a frequency of 1,000,000 periods per second. The 35 turns coil—if of the usual size—will have an inductance of about 80 micro-henries. Its resistance might be about 3 ohms, and its reactance at 300 metres will be 502 ohms. The condenser will have no appreciable resistance and its reactance at 300 metres will depend upon the setting of the dial.

Now refer to table: Column 1 gives the dial reading and column 2 the capacity. Column 3 give the reactance of each dial reading at 1,000,000 periods. Column 4 gives the total reactance of the condenser inductance combination. Column 5 gives the "impedance" which simply means the combined effect of reactance and resistance. We will assume that the circuit now forms part of a receiving set and that a circuit coupled to it is able to induce in it a pressure of 1 volt. Then column 6 gives the current which will flow, and column 7

these curves we see that the "in tune" position is at 63.5 on the dial and we learn that—tuning causes the maximum current to flow in the circuit and that it reaches a value limited only by the resistance—tuning enables us to raise to an enormous degree the voltages available to apply to our detectors. Care must be taken to remember that increase of current and pressure do not necessarily mean that the energy is increased in proportion. Watts are not always given by the product of volts by amperes.

When we tune the circuit we bring it into such a condition as will enable it to take the full advantage of the minute impulses received; we arrange that these enhanced effects are manifest just where they will be of the greatest use to us. It is of interest to draw attention to the conditions which would exist if we could make a "resistanceless" coil, that is, a "low-loss" circuit. Columns 14, 15 and 16 give some of the figures. The curve No. 4 reaches to a great height—too high for my paper; too high for all the paper ever made or likely to be made. It reaches to an infinite height.

A study of the curves will give the reader a clear understanding of why "low loss" sets tune exceedingly sharply and give such fine results. No-

tice that in the case of the 30 ohm coil moving the condenser down to 62.5, that is 1 degree off tune reduces the current to about 15/16 of its maximum. A similar change using the 1 ohm coil gives a reduction to 1/3 of the maximum value. In considering the resistance of a circuit, it is essential to bear in mind that anything which absorbs energy from it, is in effect an addition to the resistance. Thus if I couple

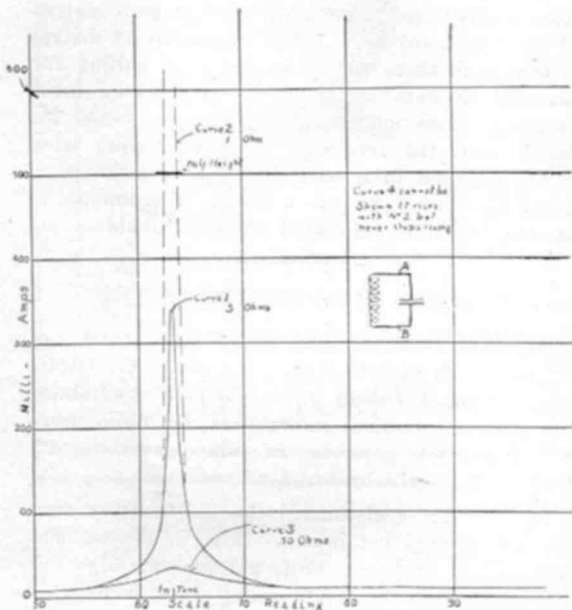

or connect any apparatus to the circuit considered above, all energy transferred to this additional apparatus is obtained from the first circuit and its losses are increased thereby.

There may be, amongst my readers, many who will take the figures given in the tables as correct. There will be others, however, who will desire to know how they were obtained and who may care to work out some similar examples themselves. For the benefit of the latter class I am explaining the methods of calculating. The mathematical knowledge required is not very extensive. It is well within the scope of the average individual. Oscillatory motion is motion which recurs or repeats itself at regular intervals. The most familiar form of regularly recurring motion in everyday life is the rotation of a wheel and oscillatory motion may be considered as that of a point on the rim of a wheel. The radius of the wheel is the amplitude and the speed of rotation is the frequency. We must find a way of expressing the velocity. Revolutions per minute

or per second would be one way. The circumference of a circle is 360° . Multiplying revolutions per second by 360 gives me a new expression for the velocity in degrees per second. Neither of these takes into consideration the size of the wheel and it is evident that the larger the wheel the greater is the actual velocity. We must therefore find another way of expressing it which will take into account the size of the wheel, that is its radius or the amplitude of the oscillatory motion.

The length of the circumference of a circle is always 6.28 (2π) times the radius. If a wheel makes 100 revolutions per second I can express the velocity of a point on the circumference thus: The point covers 6.28 "radians" per revolution, therefore its velocity will be 6.28 times 100 or 628 radians. This method takes into account the size of the wheel and so expresses the true velocity and is the method used in our calculations, because the value of Reaction depends upon velocity. At one million periods the velocity will be 6,280,000 radians per second.

The reactance of a condenser is given by

$$X_c = \frac{1}{C \times 6.28 \times f} \quad (1)$$

X is always used to denote reactance, C is the capacity in farads and f is the frequency. X_c means capacity reactance. X_L means inductive reactance. The reactance of an inductance is given by

$$X_L = L \times 6.28 \times f \quad (2)$$

L being the inductance in Henries.

Now for the table—Column 1 is the scale reading and column 2 is the capacity corresponding thereto if 100° is .0005 mfd and the condenser is a "straight line one" that is, one with semi circular and concentric plates. Column 3 is worked out from column 2 using formula (1) above. X_c is worked out using formula (2) and is found to be 502 ohms. Column 4 is the difference between 502 and column 3.

The reactance must now be combined with the resistance to give the impedance Z. Capacity reactance, inductive reactance, and resistance do not work together. Their combinations may be illustrated in the following way: Consider them as three children playing with a rope tied on to which are some apples representing the energy. X_c and X_L have hold of the ends of the rope, R stands near its middle. X_c and X_L pull the rope alternately so that the apples pass R in their motion backwards and forwards. As an apple reaches R he snatches at it and pulls it off the rope leaving a smaller supply for X_c and X_L to pull. Note

that X^C and X^L pull in opposite directions in a straight line. That is why I subtracted X^C from X^L or X^L from X^C .

Note that R pulls at right angles to this straight line as in this diagram

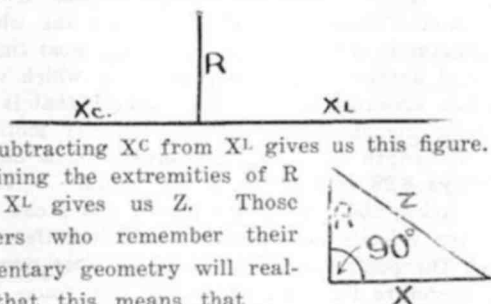

Subtracting X^C from X^L gives us this figure.

Joining the extremities of R and X^L gives us Z . Those readers who remember their elementary geometry will realise that this means that

$$Z = \sqrt{R^2 + X^2}$$

or Z equals the square root of the sum of R squared and X squared.

Using formula (3) I work out column 5. Then using Ohms law in a slightly different form,

$$A = \frac{V}{Z} \quad (4)$$

and so I worked out column 6 using formula (4). To send a current A through an inductance L requires a voltage given by this formula

$$V = L \times 6.28 \times f \times A \quad (5)$$

Using formula (5) I worked out column 7. The columns for other values of R are worked out in exactly the same way and then by using the scale readings horizontally and the figures of column 6 vertically, I lay out the shape and draw a Curve 1. The other curves are obtained in the same way using their appropriate columns. In conclusion I must express a hope that the above explanation will be of interest to at least a proportion of my readers who will find that a study of it will afford them a closer insight into the behaviour of radio circuits than can be obtained in any other way. Undoubtedly many experimenters derive a great deal of interest and amusement from tuning in various stations one after the other, but far more interesting work can be done by neglecting the outside stations and using a simple oscillatory circuit energised at first by a buzzer, and later by a valve, by adjusting circuits to tune with this little local transmitter, and noting the effects of various adjustments and above all, trying to reason out just why certain adjustments give certain results. Far more useful work in the advancement of the scientific side of radio has been done and will continue to be done by workers on the above lines, than by the use of indiscriminate transmission and reception of Morse code messages of no importance, even to the transmitter

or the receiver and of poor quality gramophone records which must reproduce the diaphragm noises of the original machine—which even in the highest priced machines, cannot be quite eliminated—plus an exactly similar set of noises from the diaphragm of the receiving telephone or loud speaker.

I do not mean to imply that "listening-in" should not be indulged in. There is too much of it. The author has recently been using a buzzer excited circuit on a wavelength of 5 metres and less and a valve excited one at about 10 metres and tuning in these waves is a fine art calling for extremely delicate adjustment. Numerous most interesting facts were noticed. It was found for example that the losses in a tinned copper wire are higher than in a bare one. The increase is beyond the power of the author's instruments to measure, but it is estimated at about double.

EVER-READY BATTERIES.

We have received from S. Hoffnung and Co., Ltd., Australian branch of the Ever-Ready Co. (Great Britain), Ltd., a handy little pamphlet containing quite a lot of practical information for radio users. We reprint below a number of points governing dry batteries which will be found of use.

(1) Failure to disconnect the H.T. battery from set or panel when not in use. It is, of course, common knowledge that valves do not consume high tension current when the low tension current is switched off, but not generally known that the panel on which the battery terminals are mounted is frequently a much poorer insulator than it should be, and quite capable of conducting a small amount of current between the two connecting terminals. This conductivity may be further increased by accumulation of dust or moisture, and while the amount of current likely to leak across the panel is small, if the battery be left permanently connected, this can mount up sufficiently to appreciably affect the life of the battery.

(2) Faulty insulation of fixed condensers placed across the high tension batteries, particularly in the paraffined paper type of condenser.

(3) Faulty insulation and touching plates of variable condensers, which in some circuits are connected across the high tension supply.

(4) When the valves are allowed to oscillate the amount of current taken is two or three times as much as the normal rate.

(5) The use of soft valves. These valves often pass an abnormally large plate current. It is not, perhaps, generally known that old valves which have had much use become soft.

NATURE'S SUPER POWER PLANT

Surprising Facts about Lightning and your Safety.

(By George M. Ogle in "Popular Science Monthly.")

THERE has been much talk recently of super-power. Eminent engineers have estimated that 80,000,000 horsepower in electrical energy could be produced by utilising fully the water resources of the country; energy equivalent to that contained in 800,000,000 tons of coal, or 200,000,000 more tons than the total annual product of the mines of the United States.

Now, though the day of super-power is still far away, though the harnessing of all available streams in the country probably will remain for years merely a dream of imaginative engineers, it is altogether likely that most persons in the United States many times in the last few months have observed manifestations of electrical energy compared with which the 80,000,000 horsepower visioned by the prominents of super-power seem weak and feeble. For every time there is a severe thunderstorm Nature discharges more electricity in the form of lightning than the total amount that could be produced by the simultaneous use of every generator, battery, and static machine that has existed since the dawn of electrical knowledge.

In every single flash of lightning you see is concentrated many times more energy than could be produced in an instant by all the electrical generating plants in the world. The present available electrical power in the world is about 10,000,000 horsepower, while the energy realised is 1/200,000 of a second by the average flash of lightning is 250,000,000 horsepower—more than three times as much as engineers say they could develop by harnessing every stream in the United States. Lightning is nature's greatest show, and for many persons their supreme source of terror. The awe-inspiring magnificence of a large display of lightning is inescapable, but the terror of lightning probably can be traced to its mystery and to the resounding roars of thunder that accompany it rather than to its actual danger. Recent scientific research however, has succeeded in stripping much of the mystery from the phenomenon and has unearthed reassuring facts that should allay much of the fear occasioned by violent electrical displays in the heavens.

Considering the enormous energy of a single bolt of lightning, it is surprising that there is comparatively little reason for man to be afraid

of it, yet this statement is well substantiated by statistics. It is true that lightning is the sixth most frequent cause of fire in the United States. Latest reports of the United States Weather Bureau show that it results in an average annual loss of more than 12,000,000 dollars of which more than 1,000,000 is in the State of Illinois, with Texas second and New York third in the list of states that suffer most.

Yet as a cause of death it is exceeded greatly by virtually every disease and every common form of violence. Only 425 persons were killed by lightning in the United States in the last year for which statistics are available, as compared with 1,038,952 deaths from all causes. The figures that you are far more likely to die in a railroad wreck, to be killed by an automobile, to drown, or even to be murdered, than to die by lightning.

Science has determined further that not more than 1 flash in 100 actually is dangerous either to man or property, simply because only one flash in 100 reaches the earth. The rest are spectacular discharges between clouds, followed by startling roars of thunder, but so far up in the air as to be quite harmless to anything on the earth. Moreover, only a small percentage of the flashes that reach the earth actually causes damage, for, lightning, like every other form of electricity, travels over the path of least resistance; and since air is not a good conductor of electricity, lightning, when it can, leaves the air to travel to the earth over some better conductor. Nowadays it is likely to find such a conductor in the form of a lightning rod, the steel frame of a city building, a metal flag pole, or a grounded radio aerial. At such times the chances are that lightning will prove quite harmless. Only when it finds a better conductor than the air in a man, an animal, a tree, a frame building, or the wooden masts of a ship, does lightning actually cause fires or the loss of life.

Telephone B 5925

CHARLES D. MACLURCAN
Consulting Radio Engineer

Pratten Building,
26 Jamieson Street,
SYDNEY

Most of the exceptionally tall structures in the world have been struck by lightning more than once, but have escaped damage because the lightning has been carried harmlessly to the ground on lightning rods. The steel Eiffel Tower in Paris, tallest structure in the world, hence an admirable target for lightning, has been struck many times without damage, despite the old adage that lightning never strikes twice in the same place. Less than a year ago a lightning bolt severed the radio aerial that stretches from the top of the tower to the ground; yet the tower itself was uninjured because of the protection of lightning rods. The Washington Monument likewise has been struck by lightning on several occasions but was damaged the first time only, in 1885 a year after it was built, and before adequate lightning protection had been installed. Many of the skyscrapers in our cities have been struck without the occupants' being any the wiser, because the steel skeletons conveyed the electricity into the earth as silently and harmlessly as electric current flows through an ordinary transmission line. Indeed, to be inside a skyscraper, or any other steel building during a thunder and lightning storm is to enjoy security. A steel ship likewise affords safety. So does a locomotive or a railroad train. A frame building properly protected by lightning rods likewise is a place of safety. So, to a great extent is a building in a deep valley. Any structure in the city where buildings are in rows, is almost entirely safe from lightning. However, you may find yourself caught out in an electrical storm some day and you will want to know how to protect yourself.

About the most dangerous place in such a situation is under a tall tree with heavy foliage, especially if you are wet. The tree, a better conductor than the air, attracts the lightning which, vaporising its sap and other moisture into a gas, causes an explosion, resulting in serious injury or death to the person near it. Probably more people are killed by lightning in this way than in any other. An open field, a beach, an open boat on sea, lake, or river; the roof of a high building, the top of a mountain, or any other similar exposed location likewise is a place of especial danger. In any of these cases your body is likely to form the tallest conductor in your vicinity, and consequently the object most likely to be struck. If caught in an exposed place during a lightning storm, get under cover immediately if you can. If you cannot, you will reduce your chances of being struck appreciably, if you lie flat on the ground or in the bottom of your boat. If indoors during a thunderstorm, stay away from chimneys.

Remember that lightning always is seeking the easiest path to the earth and the column of warm air ascending through a chimney is likely to supply it. A chimney also is likely to be lined with soot—carbon, a better conductor than the air; hence the path that lightning will take if it passes near by.

There is an old tradition that it is dangerous to hold or be near any metal objects while lightning is flashing. In the case of a wire fence, the metallic roof of a frame shed, or any metal object of similar size or larger, is true. It is a good rule to keep cattle as well as yourself away from wire fences. Much stock has been killed by huddling in fence corners during electrical storms. But to hold a penknife, a pair of shears, field glasses or an umbrella during a thunderstorm will not increase your danger. When the present widespread interest in radio began, many persons hesitated to instal radio sets in their homes lest the aerials should attract lightning. This fear probably has been dissipated, for fire-department and insurance authorities are agreed that AN AERIAL EQUIPPED WITH LIGHTNING ARRESTORS CONSTITUTES NO SOURCE OF DANGER. If properly earthed it actually will afford protection by acting as a lightning rod. It is, however, good policy to earth the aerial direct during a storm.

Although the study of lightning and its effects has enabled science to frame rules for escaping its dangers, that does not mean that you are advised to emulate Ajax and defy the lightning to strike you. Rather, it is well to recall the fate of that mythical hero and take extraordinary precautions when lightning is flashing, for lightning has a way of playing freakish tricks, often with fatal results. For example, not long ago lightning travelled down the elevator cable of a mine 2000 feet deep. Two miners who were preparing a blast were injured severely when a charge of dynamite was exploded by the flash, and 25 others at the other end of the tunnel were shocked. About a year ago a man in one of the New England states running for shelter from a sudden storm saw a sudden blinding flash followed immediately by a terrific crash of thunder. Then he was conscious of a peculiar numbness in his body. That he had been struck by lightning did not occur to him until he noticed that his shoes had been torn from his feet.

A somewhat similar case is that of a man who was struck while standing under a tree on a farm in New York several years ago. He was knocked unconscious, one arm was broken and he was badly burned. Strange to say, he was absolutely naked when he was found and the field

about him was strewn with bits of his clothing. Science recognizes several kinds of lightning, although authorities differ as to whether some types are not identical and merely appear different because of the peculiarities of the human vision. Zigzag or forked lightning is the most common type. The irregular path of the discharge is believed to be due to the presence of solid particles and electrical charges that make a jagged course along the path of least resistance.

Sheet lightning, which illuminates large areas of the sky without storm, is generally believed to be merely the reflection of forked lightning from a distance. Band lightning, a broad ribbonlike stroke, is caused by a rapid succession of discharges along a path that has been slightly displaced by the wind. Ball or globular lightning is very rare, if it occurs at all. Bead lightning which is described as a chain of luminous balls, is another type of lightning regarding the existence of which authorities are not agreed. There is also St. Elmo's fire, a globular light observed infrequently on masts of ships.

In addition to all these there are induced charges — local electrical disturbances between metallic bodies, accompanying the discharge of lightning nearby. These frequently cause fires if inflammable material is near, but are not generally dangerous so far as human beings or animals are concerned. The vast majority of victims of lightning are not killed instantly. They are merely stunned and can be revived by the application of artificial respiration and the other first-aid measures commonly employed in cases of drowning or asphyxiation.

Like many other manifestations of the mighty power of nature, lightning is coming gradually under the control of science and when the public generally understands the nature of lightning and the means of avoiding its dangers, its hazard to human life and property will become virtually extinct.

THE RADIO CONVENTION

Mr. C. E. Ames, the hon. secretary of the South Australian Division of the Wireless Institute, has been chosen to represent South Australia at the Second Annual Radio Convention which is to be held in Perth in August. It is to be hoped that all States will be represented.

CORRESPONDENCE

MORE ABOUT THE REINARTZ.

To the Editor.

Dear Sir,—I have perused with interest G.W.S.'s notes on the all-wave Reinartz, and I have attempted to analyse his curves, but without much success. Take curves 1 and 3; as they are convergent, it follows that if sufficient capacity had been available they would have met at about 480 metres. This is quite impossible. It would mean that the inductances of the coils must be equal. Stray and self capacity would be negligible in comparison with the condenser capacity required for 480 metres. But although they are both 15 turn coils, No. 3 is larger than No. 1, and as inductance is approximately proportional to area enclosed, No. 3 must have a larger inductance than No. 1. Now compare curves 1 and 2. These are divergent, as they should be. Produce them until they meet at about 10 metres. If there

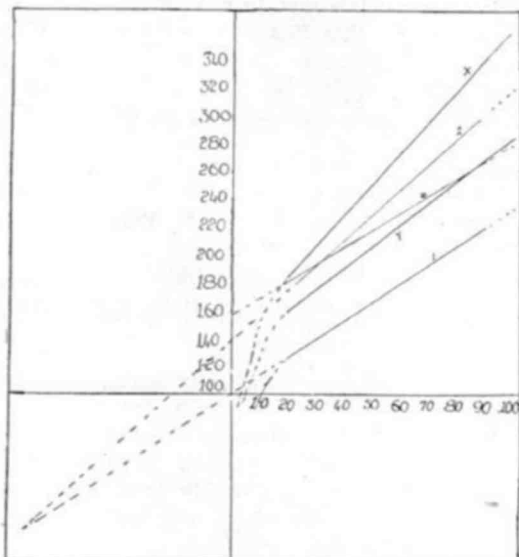

were no stray or self capacity they would cross at zero W.L. Assuming that the 11 plate condenser had a capacity range up to .00025 mfd., we find that the total capacity outside the condenser amounts to 65 per cent. of the condenser, or about .00016. The crude flex condenser used in the aerial and the coupling between aerial coil and grid coil is insufficient to give us this result. We must seek elsewhere for an explanation.

If G.W.S. examines his Gilfillan condenser he will notice two peculiarities. The "entering" corners of the moving plates are well rounded off, and the fixed plates are cut well back from the diameter.

Apart from these the condenser is a "straight line capacity" one. From about 20 deg. upwards the capacity increases by amounts proportional to the increases in scale reading. From 20 deg. downwards the capacity falls away very rapidly, so that the W.L. curves must curve downwards from 20 deg. approximately as shown in my diagram, which is a copy of G.W.S.'s with additions. Now, assuming curve 1 to be correct from the data given for coil 2 its W.L. curve should be in the position shown by curve X, and coil 3 should have its curve as shown by Y. However, curve 1 cannot be a straight line, because the condenser being a straight line one, it follows that the W.L. curves must be square root ones. That is, they must bend downwards. I trust that G.W.S. will not think I am too severe in my criticism, which is made with a sincere desire to assist him. I must congratulate him for having undertaken some genuine experimental work instead of eternally "listening in, listening-in." He comments on W. A. Stewart's quotation re W.L. range: Whilst it is quite possible that $10 \times A2$ would give the minimum, the fact that $10 \times (A1 + A2 + A3)$ gives the maximum is purely a coincidence. $A1$ and $A3$ play a negligible part in determining W.L. range. $A3$, G.W.S. found, had no appreciable effect on the set, whether used or not. Quite so. It merely forms part of what may be considered an auto transformer having a step up ratio of 3—4. The primary is $A2$ and the secondary is $A2 + A3$. This step up is too small to have any effect, and, besides, the extra impedance added by $A3$ probably annuls any increased voltage obtainable from the transformer effects.

It is possible to make quite a number of further deductions from G.W.S.'s results, but I refrain from doing so in the hope that there may be another correspondent who has carried out some investigations on this circuit on lines similar to G.W.S., and who may care to air his views and make public some results.—Yours, etc.,

E. JOSEPH.

(Editor's Note.—Departing from ancient custom, we sent a copy of the above letter to G.W.S., whose reply is printed below.)

(To the Editor)

Sir,—I have perused Mr. E. Joseph's comments on the results obtained by me with the "Reinartz" circuit and published in "Wireless Weekly" of April 3rd. Mr. Joseph would be undoubtedly right in his analysis of the curves produced if it was only "the coils and condensers" themselves

that were involved in the tests. There are two factors as I see it that must have some bearing on the results obtained.

My set was built with terminals placed to receive the tuning coils where it is practically surrounded with the rest of the apparatus used in the set. Capacity inter-action must therefore be taken into consideration. When I built the 3½ in. coil I found that it was too large to occupy the position taken up by the 2½ in. coil. I therefore added length of heavy copper wire so that it would stand out away from the other apparatus. This is cause number 1.

The natural wave length of my aerial external system is 135 metres. In the set is a "de-tuning" coil having a wave length of about 50 metres. The position of the tapping switch on this coil was varied for different tests to obtain the best results in each case, and as the aerial system was thereby varied at times from 135 to 185 metres, a corresponding variation is made on the condenser reading. This is cause number 2.

The small "Flex. condenser" in the aerial system was not used in any of the tests.

How far these causes will vary the direction of the curves from their theoretically correct position I am not prepared to say off hand, but I am quite prepared to repeat the experiments in Mr. Joseph's presence and by careful noting of positions of the various apparatus, endeavour to assign the cause. The curves shown by the full lines only are the results of actual tests.

I have further and more complete curves nearly finished and if they are of sufficient interest I should be pleased to submit them for publication in "Wireless Weekly." Yours, etc.,

G.W.S.

To the Editor.

Sir,—In your issue of April 3rd, G.W.S., in an article on the Reinartz all wave receiver, questions the use of the untuned portion of the grid coil.

It is merely part of the grid coil, and therefore there is no virtue in leaving it untuned. As G.W.S. demonstrated, the set works just as well without it.

With regard to the familiar 1 to 3 ratio between aerial and grid coils, experience has proven this to be the best all round proportion, in that it strikes the happy medium between two conflicting requirements. It is not, however, the most efficient for more than a few wavelengths.

In the modified Reinartz circuit, the aerial coil also serves as a reaction coil. Unfortunately, where-

as the aerial coil turns are best kept low in order to obtain selectivity, it is desirable to increase them for reaction purposes, especially in the higher wavelengths.

An average ratio is the most obvious solution, but I have found variable coupling a better one. The ratio of turns may then be 1-2 for all wavelengths; control of reaction is finer—if possible—than in the original Reinartz circuit, and the set is much more selective than with the fixed coils.

Adjustment of the grid leak is a somewhat ticklish operation, but the results will repay one for the time spent on it.

When just right it is possible to apply reaction right up to the oscillation point, and have the satisfaction of knowing that even should a strong signal send it over it will cease of its own accord.

Yours, etc.,

T.N.G.

To the Editor.

Dear Sir,—Being a constant reader of "Wireless Weekly," and a member of the Victorian Section, W.I.A., I wish to draw attention to your Victorian notes which have been published from time to time. In my opinion they are unfair criticisms by one who wishes to bring discord among the members of the W.I.A. In the issue of 3rd April before me, reference is made to the class of instruction now being held to instruct enthusiasts who are anxious to sit for examination (the P.M.G.'s), and Mr. Love, the hon. lecturer, is taken to task by one who was present one night only, and therefore is not in a position to judge. This report was discussed last night by the members of the instruction class, who passed a vote of thanks to Mr. Love for giving them his valuable time, knowledge, etc., and all appreciated the valuable service he was giving to them and the W.I.A. Mr. Love took up this work because no one else would give this work without fee or reward, and if the writer of your article has so much fault to find with the Victorian Section of the W.I.A., how is it that he remains a member of it?

Yours, etc.,

A MEMBER OF THE INSTRUCTION CLASS.

(To the Editor)

Sir,—I have been going to write to you for some time about the want of an article or two that will apply to the wants of the outside men like myself.

Your articles are immensely interesting and

instructive, but leave a whole lot to be desired at times where we are concerned. B.C.Ls at this distance have to provide for D.X. almost from the jump and that necessarily means bigger sets, more expense and bigger chances taken when trying to get good results. Your 4 valve receiver in this issue, April 3rd, seems to about fit our case, and I am altering my outfit to that to see if I can improve on my results to date. An article like this gives some real idea what are the best parts to get, as my experience is that some of the radio supply places, have no idea what we have to work for, and fail sometimes to fill our orders right, not taking into account the narrow margin between success and disappointment.

W.W. fills the place of the shops for the outback man, as he sees there what he wants, where he can get it, and he is also kept up to date in respect of new apparatus.

I have to thank you for at length giving us something that meets our case while still of interest to the city man. Yours, etc.,

MERINO.

Beaconsfield. Ilfracombe. C. Q.

13/4/25.

(To the Editor)

Sir,—It was with great interest that I noted Mr. Harry Stewart's remarks regarding short waves in your last issue. However, I would like to raise a few points regarding some remarks therein. Firstly, I did not claim anything new in my reception without aerial or earth; it was sent in to "W.W." purely as an item of interest. In the second place, I quite agree with him that the three coil set he mentions will buck things up; but it would be the stage of audio—not the circuit. Detector plus one of A.F. without aerial or earth is as good as detector plus same; it is in Sydney anyway, so why not in Fort Moresby? Now about that 10 foot aerial; if I could hang my wireless cabin to a 50ft. mast, sure would use a small aerial, but as I can't, I prefer a 50 foot vertical wire. To use such a small aerial, it would necessarily be in my operating room—a few feet off the ground and badly shielded on all sides. However, I can't argue against results and Mr. Stewart sure gets 'em. 23 Yanks in half an hour isn't to be sneezed at—keep it up o.m.! 73's,

LAURENCE E. DEANE.

Radio A-1863.

Havilah Road, Lindfield.

Wiles' Wonder

56-62 GOULBURN ST. (1 door from Pitt St.)

384 PITT ST. (near

SAME QUALITY. SAME PRICES

Established Over 20 Years

Have the pleasure of making your own Radio Set in a few hours of your spare time, with a screw driver, pliers, and soldering iron, and spend a thoroughly enjoyable evening putting together these famous sets.

Only the best quality parts are supplied, including Bakelite Panel drilled and engraved. The Accessories include Dry Cell Valves, Batteries, Headphones, Soldering Iron, Solder, Screws, and Instructions for Assembling and Operating, which are so clear that you cannot go wrong.

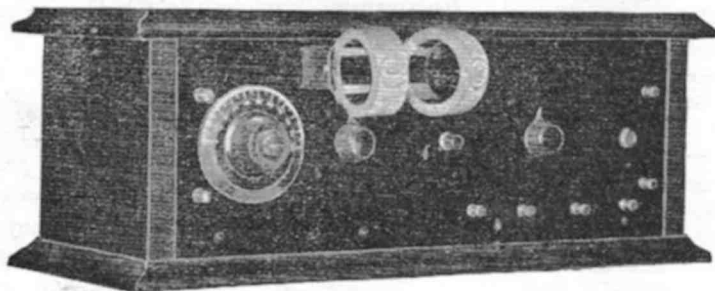

Illustration of 3 Valve Set constructed from advertised parts.

Prices

Complete Parts for 1 Valve Set	£6 8 1
Maple Cabinet for 1 Valve Set	1 5 0
Complete Parts for 2 Valve Set	9 17 4
Maple Cabinet for 2 Valve Set	1 5 0
Complete Parts for 3 Valve Set	12 13 4
Maple Cabinet for 3 Valve Set	1 10 0
Complete Parts for 4 Valve Set	17 3 3
Maple Cabinet for 4 Valve Set	2 5 0

Amplion New Junior

MODEL AR111.



The New Junior is an entirely new amplion model and provides a highly finished Loud Speaker with a metal horn at a low price. Although the cost is so moderate the instrument is one of real efficiency, and the appearance is exceedingly attractive.

Mail Order Dept.

60 Goulburn Street

Write for Price List, R6.

OUR GUARANTEE: It is our intention that every article listed herein shall be truthfully described. Therefore, we guarantee that you take no risks whatever in sending us your order, for, unless you are completely satisfied with the goods and your savings, we will promptly return your money and all transportation charges you have paid. The articles enumerated above are only portions of our complete line.

Powerful Wireless

ST. (near Goulburn St.)

23 PITT ST. (Near CIRCULAR QUAY).

LOW PRICES. SAME SERVICE.

Over 20 Years.

Amplion Music Master

MODEL AR15.

Reproduces Radio music and speech with a fidelity comparable to head telephones, while the volume is unusually loud for an instrument working on the telephonic principle.

The design provides an enamelled tone arm of standard steel, a polished oak trumpet, and rubber connector eliminating all undue resonance in the entire sound conduit. An exclusive "Amplion" feature.



Amplion Dragon

MODEL AR19.



This revised home table type speaker is one of the best known Amplion Models. It is one of the most useful models for home use, being fitted with non-resonating Sound Conduit with oak trumpet hinged to the weighted electroplated base, allowing the horn to be tilted to any desired angle.

LOUD SPEAKER PRICES—AMPLION.

Dragonfly AR102	£2	0	0
New Junior AR111	4	0	0
New Junior De Luxe, AR114	5	5	0
Standard Dragon, AR19	8	0	0
Music Master, AR15	9	0	0

Sterling Dinkie	£2	17	6
Sterling Junior	4	15	0
Sterling Audiovox	9	0	0
Western Electric, £2/19/6, £7/2/6,	16	0	0
Magnavox M4	8	0	0
T.M.C.	8	0	0



Amplion Dragon Fly

MODEL AR102.

This little instrument is the very latest in Loud Speakers, and is now being marketed for the first time. It has been perfected after many years of experiment and research on the part of Wireless experts, and is an absolute revelation in the purity of tone. Although astonishingly small and compact, the results to be obtained from it are as near perfection as it is possible to reach at the present stage of scientific progress.

We guarantee every article you buy from us to be satisfactory in every detail. For your saving, you may send back everything you buy from us, and we will refund only portion of our price list R6.

The Amateur's Proficiency Certificate

By "WIRELESS WEEKLY."

(Continued.)

THIS week we pass on to the more interesting stages of these series of articles, viz., primary and secondary batteries as used for radio purposes.

Primary Cells

Consist of three essential constituents for the production of E.M.F., viz., a positive plate, a negative plate, and an exciting liquid. According to the nature of the plates and the liquid, a certain D.P. is set up between the plates. When the positive and negative plates are joined together through an outside circuit and a current flows, the chemical energy stored up in the plates of the cell is converted into electrical energy. The general action of primary cells may be briefly summarised as follows: The negative plate—generally zinc—dissolves gradually in the exciting liquid. The positive plate—copper, carbon or platinum—remains unaffected, and a film of hydrogen gas accumulates over it; this process is called "polarisation." To prevent polarisation (which increases the resistance of the cell) a fourth substance termed a depolariser is introduced in the cell to absorb the hydrogen. The conventional way of considering the direction of the flow of electric current is from positive to the negative terminal. As we have seen in previous articles, however, the current really consists of an electron flow from the negative to the positive terminal. The E.M.F. or D.P. (difference of potential) between the terminals on open circuits depends entirely on the substances used for the positive plate, negative plate and exciting liquid, and not on the size of the cell. A diluted solution of sulphuric acid in water or a saturated solution of sal-ammoniac are commonly used as exciting liquids. The resistance of the cell depends upon the area of the plates immersed, their distance apart, and the specific resistance of the liquid. The larger the plates and the closer they are together, the less is the internal resistance. Readers who are contemplating building up their own "B" batteries will be wise to bear this in mind.

The advantage of a large cell is not in the value of its E.M.F., but in its smaller resistance, owing to the area of surface contact, it has a larger capacity, because more energy can be stored in the chemicals, and therefore lasts longer. When cells are arranged

in series, the total E.M.F. is the sum of their separate E.M.F.s., and the total resistance is the sum of their separate resistances. When they are connected in parallel (all positives to one terminal and all negatives to another) their total E.M.F. is that of one cell, and their total resistances that of one cell divided by the number of cells (assuming, of course, that each have the same E.M.F. and resistance).

Secondary Batteries, Accumulators or Cells.

A secondary battery or accumulator is an arrangement from which an electric current may be drawn for a certain time like a primary battery; unlike the primary battery, however, when it is exhausted it may be recharged by having an electric current passed through it. An accumulator does not store electricity, it stores energy; when it is being charged the electrical energy imparted to it is transformed into chemical energy, which is stored in the cell. Then when the cell discharges, that is, when an outside circuit is completed through which current can be forced by the E.M.F. of the cell, the stored energy is reconverted into electrical energy.

A simple form of accumulator is one with two lead plates immersed in sulphuric acid diluted with water. This is chemically described as H_2SO_4 . The letters H_2SO_4 denote the nature of the atoms that go to make up a molecule of the substance; thus a molecule of sulphuric acid contains two atoms of hydrogen (H_2), one atom of sulphur (S), and four atoms of oxygen (O_4).

Charging the Accumulator.

When a source of direct current is joined up to the two lead plates as in Fig. 1, + to + and - to -, some of the molecules of the acid and the water are ionised, i.e., broken up into positive and negative ions of equal but opposite charges, thus:

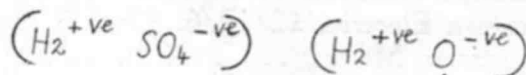

These form the carriers for the current through the electrolyte. When the cell is connected to the source of power, the positive hydrogen ions are attracted to the cathode and the negative oxygen ions to the anode. Each positive hydrogen ion on reach-

ing the cathode joins with an electron (supplied by the charging current), and a neutral atom results. Two atoms combine to form a neutral molecule of hydrogen gas (H_2). The lead and hydrogen do not combine chemically, but the surface of the lead becomes smoother and covered with pure spongy lead of light slate colour.

Each negative oxygen ion at the ANODE joins with a positive lead ion (i.e., a lead atom less an electron), and a neutral molecule of lead peroxide is formed, which is deposited on the anode. As more oxygen arrives at the anode the plate becomes chocolate brown in colour. When no more oxygen can

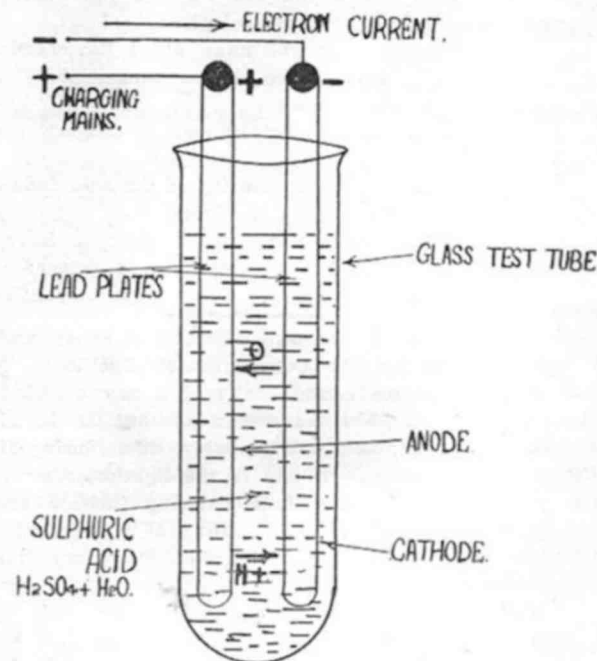

combine with the lead (which is not until the coating of brown lead peroxide covers the whole surface submerged), the oxygen will then rise to the surface and the plate "gases" freely. Thus the charged accumulator consists of positive plate, lead peroxide coating, chocolate brown colour, negative plate, spongy lead coating (light slate colour). A D.P. will now exist between the two plates of approximately 2.2 volts. If disconnected from the charging mains and allowed to discharge through an external circuit, a current will flow from anode to cathode (see Fig. 2), but only for a short time, as the plates have only a very small "holding power," due to the small amount of active material on them. This type of accumulator, however, is very suitable to supply the plate current of receiving valves, and can be very cheaply constructed.

With the commercial types of accumulators the holding power is increased by furrowing or grooving the working surface of the lead plates. The prepared surface is then filled with the active material—lead peroxide or spongy lead. The greater the number of plates in a cell and the larger their surface, the greater will be the capacity and current output. The positive and negative plates are arranged alternately, each group being connected at the top by lugs to a lead bar. The negative group contains one plate more than the positive group, except, of course, in two-plate cells.

The plates are placed close together to ensure small internal resistance, and are usually kept apart by separators made of wood, glass, or celluloid.

The Electrolyte.

The sulphuric acid and water must be free from impurities. If distilled water is not available, rain water or melted artificial ice is recommended. Care should be exercised in the mixing. When mixed with water a great amount of heat is developed. The acid must be added gradually to the water and not used till cool. On no account must water be added to acid. As will be explained shortly, the acid becomes weaker as the cell is discharged, and will fall to about 1.170 at 1.85 volts—the point at which discharging must be ceased. Its strength is recovered on charging.

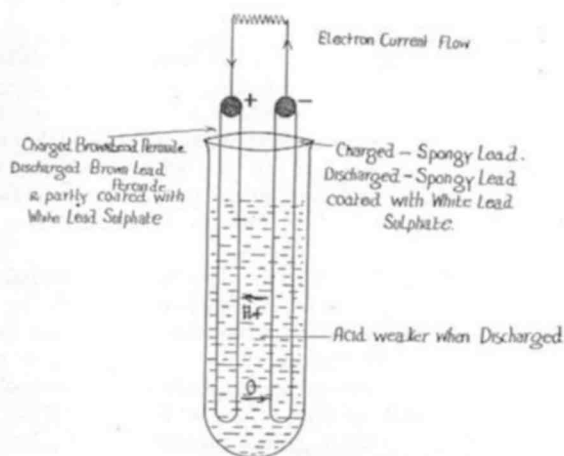

Most makers issue directions regarding the density of acid, charging rate, etc. These must be carefully carried out if the battery is to be maintained in a state of efficiency. The first charge is always a very important one; a long, slow charge will generally be found the most satisfactory. The acid will fall in specific gravity as soon as it is poured into the cells. During the charge it will gradually rise, and the charge should not be broken until the voltage and specific gravity show no rise over a period

of four to five hours. A gas is being given off freely from all plates discharging. The discharge current flows in the opposite direction to the charging current. Compare Figs. 1 and 2. Oxygen ions flow to the negative plate and hydrogen ions to the positive plate. At the positive plate the hydrogen gradually reduces the peroxide coating, then the acid readily attacks the plate, and lead sulphate (white) is formed on it. Thus the peroxide is gradually removed and the plate becomes partly coated with white lead sulphate. At the negative plate, the oxygen ions form with the lead, and the acid converts the lead as above into white lead sulphate. Thus the negative plate also becomes partly coated with lead sulphate.

Note.

In these two sets of actions, some acid is used up, and water is produced, causing the specific gravity of the acid to fall. The voltage should not be allowed to fall below about 1.85 volts. The specific gravity will be about 1.170 at this stage. If the discharge is carried on persistently beyond this point, more sulphate will form on both positive and negative plates, and when each plate is totally covered the voltage will be zero.

Caution.

A cell must not be left for any length of time in a discharged state.

Recharging.

The process consists of removing the sulphate from each plate. At the positive plate the oxygen ions again arrive and combine with the lead of the lead sulphate to form the brown peroxide, the SO₄ being restored as acid to the electrolyte. At the negative plate, hydrogen ions arrive; the SO₄ to form acid and spongy lead remains.

Note.

By the action at each plate acid is restored to the electrolyte, thus raising the specific gravity in the recharging process. When the sulphate has been entirely removed from the plates, the hydrogen and oxygen gases have no more work to do, and they rise in bubbles to the surface and escape. That is, the cell gases freely. When the cell is fully charged and lying idle the plates are less liable to be attacked by the acid. The charge in ampere hours should generally be about 5 per cent. more than the discharge in ampere hours.

Tests for Completion of Charge.

(1) Appearance of plates: Positive, chocolate brown; negative, slate grey. No traces of white on either.

(2) Plates gassing freely.

(3) Specific gravity of acid about 1.250, or according to makers instructions.

(4) Voltage, 2.5 to 2.7 volts whilst charging.

Sulphation.

Sulphating, as was explained previously, is caused by accumulators standing idle in a discharged state by too strong acid, or by over or too rapid discharge. Moderate sulphating may be removed by long continued charging at moderate current; if long over-charge is ineffective, remove acid and charge damaged plates at normal rate for 24 hours in a solution of 1 lb. pure sodium sulphate per 4 pints of water.

Questions Based on the Above Article.

(1) How would you tell whether your battery was charged or not without a hydrometer?

(2) Explain what you know about the chemical action which takes place in an accumulator (a) charging (b) discharging.

(3) What makes a battery gas on completion of charge?

(4) Explain why the density of the acid falls on discharge and rises again on charge.

(5) What causes the positive plate to have a chocolate brown colour on completion of charge?

(6) How would you get rid of slight sulphation?

The first of the two 1200-ton steamers under construction for the Commonwealth lighthouse service at Cockatoo Island Dockyard is now practically ready for sea. The vessel was launched on the 11th December last, and will probably leave during this month on her maiden trip in the lighthouse service.

One of the important finishing touches being given the vessel is the installing of a standard 1½ k.w. wireless telegraph installation emergency transmitter and valve receiving set by Amalgamated Wireless (A/sia) Ltd. This set is of the same type as a large number of other installations that have been fitted in ships by the same company, and which are noted for their record working in the Pacific and Indian Oceans.

The Union S.S. Company's well-known sea-going salvage tug Terawhiti, which is stationed at Wellington, New Zealand, was fitted with special wireless installation by the Amalgamated Wireless Company several years ago, and the wireless facilities thus provided have been found of considerable value on various occasions.

About a fortnight ago the s.s. Corinna broke a tail shaft, and the Terawhiti was sent out to tow the disabled steamer a distance of 175 miles to Wellington. Throughout the voyage the wireless installation in the salvage tug kept up communication with the coast station at Wellington, and the owners were thus able to be kept fully informed of the progress being made.

A Big Season Expected

CORBETT DERHAM'S MOVE TO LARGER PREMISES.

WINTER keeps people indoors more than the summer, and experience has already proved that with the advent of colder weather enthusiasm for radio grows stronger. Already Messrs. Corbett Derham and Co. Pty., Ltd., have noticed a decided improvement in wireless activities, and their Sydney office, which has only been opened a few months, has already found it necessary to move to larger premises to enable them to cope efficiently with the coming winter trade.

The commodious new premises pictured above are situated at 231 Clarence Street, and are the headquarters for New South Wales for such prominent accessories as Ormond condensers, Brunet transformers, Brunet loud speakers, headphones, etc., as well as a multitude of the firm's own patented products. Corbett Derham's skilled laboratory staff are responsible for many of the latest radio improvements, and the volume of sales of their "Tuna" products acclaims the appreciation of a discriminating and ever-growing "radio" public.

It is interesting to note that the sales organisa-

tion of the head office in Melbourne has found it necessary to trouble its floor space during the last two months, which augurs well for the future of radio in Australia.



Ramsay Radio Receivers & Supplies

43 plate Magnus Condensers, plain ..	17/6
23 plate Magnus Condensers, plain ..	13/6
46 plate Magnus Condensers, vernier ..	22/6
26 plate Magnus Condensers, vernier ..	18/-
Parts for .0005 Plain Condensers ..	7/6
Parts for .001 Plain Condensers ..	10/-
3 Gang Magnus Bakelite Sockets ..	12/6
Bakelite Knob for Rheostats ..	1/3

4in. Bakelite Dials ..	3/-
Buck's English Transformers ..	12/6
Powerquip English Transformers ..	18/6
Marco Transformers ..	32/6
Polar 2 coil Vernier Mounting ..	10/6
Pranco 2 coil Vernier Mounting ..	15/-
Brandes 4000 ohms Head Phones ..	35/-
H.C. Coil Plugs ..	2/3

FULL RANGES OF RADIOKES AND ATLAS HONEYCOMB COILS AND LOW LOSS COILS ALWAYS IN STOCK.

Ramsay Sharp and Company Limited

Radio Engineers

217 George Street, Sydney

HOWELL'S Sale & Exchange

FOR
THE LATEST
AND
BEST
IN
WIRELESS
AT
LOWEST
PRICES

19 Barlow Street
SYDNEY

PHONE: MA 1133
OPEN TILL 9.30 FRIDAY NIGHT

QST

A Magazine Devoted
Exclusively to the
Wireless Amateur.

Published Monthly.
Subscription, 18/- per
annum, post free.

Distributor for Australia:

Phil RENSHAW

DALTON HOUSE,
115 Pitt Street, Sydney
Box 2816, G.P.O., Sydney.

VACUUM TUBES

In Wireless Communication
A Practical Text Book
for operators and experi-
menters

By
Elmer E. Bucher

This volume shows over
140 different circuits for
the practical use of
vacuum tubes as detec-
tors Radio or Audio Fre-
quency Amplifiers, Re-
generative receivers
Beat Receivers, etc.

Price 12/6, Postage 8d.

N.S.W. Bookstall Co. Ltd.
Corner, Castlereagh and
Market Streets,
Sydney.

"RADION" Panels and Parts meet every require- ment of the radio set builder

There are many reasons why you should build your radio receiving set with Radion panels and parts.

First: Radion has proven beyond a doubt to be the supreme insulation. It is made exclusively for radio work and far excels any other material in the four main characteristics required for wireless, namely, low angle phase difference; low dielectric constant; high resistivity and the low absorption of moisture.

Second: Radion is easily worked. It can be sawed, drilled, machined and otherwise worked without the slightest danger of chipping or cracking.

Third: Radion Mahogany Panels have the actual surface graining of fine, highly polished mahogany while black Radion panels have a beautiful ebony finish.

Fourth: In cost, Radion is far more economical than any other material.

Fifth: Sets made with Radion Panels and Parts will give much better satisfaction.

Do not jeopardize the value of your receiving set by using cheap, trashy materials. It will pay you to always insist upon genuine Radion. Look for the name stamped on every piece.

International Radio Co., Ltd.
91-92 Courtenay Pl., Wellington N. Z.
200 Castlereagh St., Sydney, N.S.W.

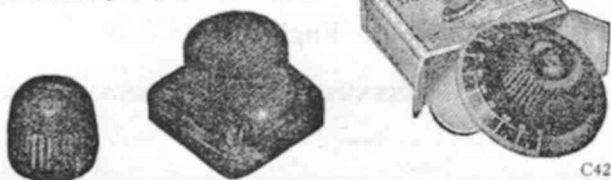

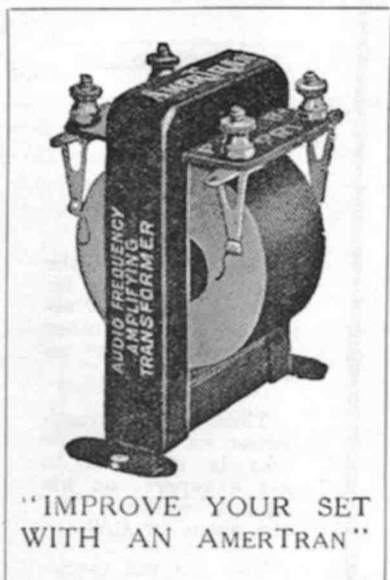

"IMPROVE YOUR SET
WITH AN AMERTRAN"

You are sure of the best results
only by using the best
Transformer

"AMERTRAN"

Squeals and howls in audio transformers are due to regeneration between the tubes and the amplifiers. To get rid of this trouble, very careful wiring is necessary. The grid and plate leads must be short and straight, and the other wires of the set must be grouped together. Insulated wires should be used, if possible. A proper "C" battery should be used in the grid circuit of each tube to match the first battery used in accordance with directions given with the transformer. Also, squeals may be avoided by placing a resistance of $\frac{1}{2}$ megohm across the secondary of the last transformer. Capacity should not be placed across the secondary, but may be placed across the primary. This capacity may be as high as .004 M.M.F.

Australian Distributors:

WELBY RADIO CO. 13 ROYAL ARCADE, SYDNEY

25s. each



D.V.3
Filament, 3 volts .06 amp.
Both Types Fit Standard American
Socket.



D.V.2
Filament 5 volts .25 amp.

MADE BY

De Forest

THE MAN WHO INVENTED BROADCASTING

DE FOREST VALVES

TYPE D.V.2—Takes 5 Volts at $\frac{1}{4}$ Amp. on Filament 25/- each

Plate Voltages, Detector . . 18-22½ Volts
Plate Voltages, Amplifier 60-150 Volts

TYPE D.V.3—Takes 3 Volts at .06 of an Amp. on Filament 25/- each

Plate Voltage, 16-22½ Volts, Detector
Plate Voltage, 60-120 Volts, used as an Amplifier.

Both Types Fit Standard American Socket.

(Wholesale Only)

INTERNATIONAL RADIO CO. LTD.

200 Castlereagh Street Sydney, N.S.W. Phone: MA 1387

Also at 91-93 Courtney Place, Wellington, N.Z.

'Tis Quality Radio that Counts

CALL AND HEAR OUR SETS AND LISTEN TO THE
CLEAR RECEPTION.

PRICES RANGE from £8 for a 1 valve set to £75 for a
5 valve set.

B Batteries.

WINCHESTER.

22½ V., large capacity cells	13/-
45 V., large capacity cells	26/-

New Gramophone - Radio Combination

Its tone will satisfy the musician and its appearance will
beautify the home.

MAKES ENTERTAINMENT AT HOME EASY

Terms Arranged if Required

ENQUIRIES INVITED FROM COUNTRY CUSTOMERS.

Write for our New Radio Catalogue
which gives circuits and Prices for all component parts.

Mick Simmons Ltd

Remember our Motto—Quality Consistent with Reasonable Prices

Headquarters: HAYMARKET, SYDNEY
THE WORLD'S GREATEST SPORTS STORE

Q.S.L.

The meaning of the three letters QSL is: "Please give me a receipt" — or, in other words—"Send me an acknowledgement."

There isn't a transmitter on the air now who is not glad to get a report on his signals, whether they are phone or C.W.

You can put everything you want to say on a Publicity Press QSL card. It takes only a minute to fill in and conveys all the information the transmitter wants.

Over the last few months we have printed thousands of these cards for both transmitters and receivers, among them 2UW, 2CX, 2BF, 2LM, 2WW, 4CK, etc.

There is a QSL card for every purpose and they may be had either from stock or to suit individual tastes.

Write, phone or call.

Publicity Press Ltd.

Printers and
Publishers -

12-16 Regent Street
SYDNEY

Phones Red. 964 & 930.

Wireless Institute of Australia

VICTORIAN DIVISION.

SECOND ANNUAL WIRELESS EXHIBITION.

EVERYTHING is now well in hand for the official opening by the Honorable the Postmaster-General of the largest Wireless Exhibition yet held in Australia. This will be held under the auspices of the Victorian Division of the Wireless Institute of Australia in Wirth's Olympia, from 10.30 a.m. to 10 p.m. daily, from May 20th to May 30th, 1925.

The whole of the available floor space has been allotted to Melbourne's leading manufacturing and retail firms, who, from present advices, will exhibit the very latest ideas in complete wireless receivers and the finest component parts for those who wish to construct their own apparatus. Some of the firms are also showing the latest in electrical household appliances and novelties, and anyone who visits the exhibition will be well repaid, but are advised to "come early and come often," as there will be such an enormous range of apparatus to be compared.

A series of competitions will be held for those who have assembled their own apparatus, particulars of which are given below. These competitions are

open to any home constructor, whether a member of the Institute or not, and if an application form cannot be obtained from the local dealer, cut out and use this one. A handsome certificate will be presented to all those whose exhibits are accepted.

A complete experimental wireless station is being erected, which, in connection with an outside station, will give the public some idea of how wireless communication is carried on, and on a miniature scale will show how concerts, etc., are transmitted from the broadcasting station and received by the listener-in.

The Western Electric Company is installing a public address system, and during each evening session experts will give short lectureries on simple wireless subjects, such as "Faults, how to find and rectify them," "Improved reception," etc.

In order to discover that person in Victoria who can read Morse signals at the greatest speed, both amateur and commercial, an elimination test will be held just previous and during the exhibition. On Sunday, April 26th, Morse signals will be transmitted from experimental station 3JU on a wavelength of approximately 85 metres. A "cq" call and a number of "v's" will be given at 10 p.m., and at 10.5 p.m. Morse at a speed of 20 words a minute will be transmitted for five minutes. At 10.15 p.m. signals

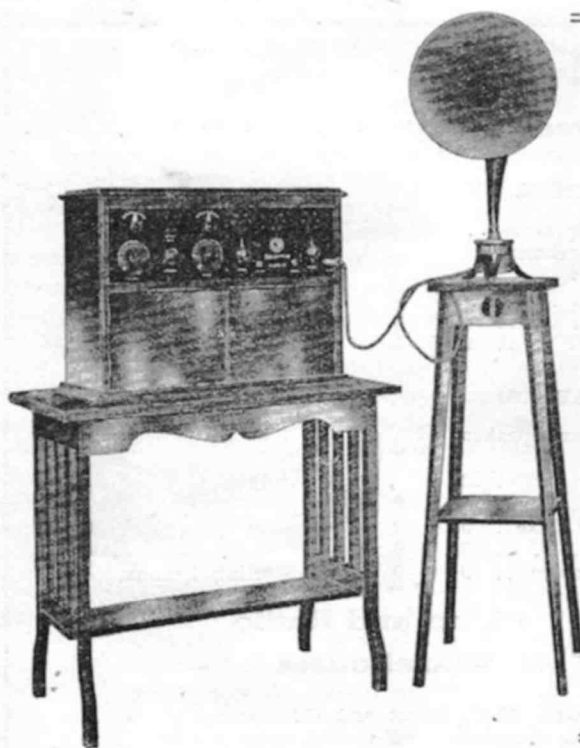

9000 Miles on a LOUD SPEAKER

This is the authenticated performance of our "BURGINPHONE" Broadcast Receiver.

Designed to Cover All Wavelengths Between
250 to 2000 Metres.

The above reception proves that these Australian-made machines are capable of receiving just as well on the short wave bands as on the higher band.

Made in 4 Models—4, 5, 6, and 7 Valves.

Prices and particulars sent on request.

BURGIN ELECTRIC CO. LTD.

Licensed Wireless Manufacturers & Suppliers,

340 KENT STREET, SYDNEY.

will be transmitted at 25 words per minute for five minutes, and at 10.25 p.m. for five minutes at a speed of 30 words per minute.

On Thursday, April 23rd, at 9 p.m., at the Centreway, Chapel Street, Prahran, the same procedure will take place, but with a buzzer. This is for those who do not possess wireless receivers.

A.R.R.L. Vigilance Committees to Investigate Interference with Radio Reception

BELIEVING that radio receiving conditions throughout the United States can be improved through systematic co-operation of amateurs, the American Radio Relay League has arranged for the appointment of vigilance committees, the object of which will be to relieve trouble from code interference.

The regulations of the Department of Commerce, together with the new assignment of wavelengths for broadcasters and code transmitters, have done much to clear up interference, but the A.R.R.L. is determined to improve conditions even further with the help of amateurs having a knowledge of the code.

These vigilance committees are to be appointed by League traffic officers in all large cities in the country, where they will work in co-operation with

All logs must be in the hands of the secretary at 327 Collins Street not later than Saturday, May 2nd, and the first three in each section will be required to undergo a further test at the evening session of the exhibition on Wednesday, May 27th, fine silver cups being presented to the winners.

radio clubs and newspapers. The organisation of the committees will be under the supervision of assistant division managers of each State. Each committee is to consist of three radio fans with a knowledge of code, one broadcast listener, and a newspaper man.

The chairman of each committee will solicit complaints of interference through the local newspapers, and will thereupon assign cases to various members for investigation. The results of such investigations will be submitted to the committee, which will then make such recommendations as appear necessary.

The committee will not take any definite action unless it is found that the interference is caused by amateurs. If members of the A.R.R.L. are found to be violating any of the regulations of the Department of Commerce, strenuous measures will be taken, and if conditions are not immediately remedied it

LOUD SPEAKERS !

New Shipments Just Arrived

STERLING PRIMAX.

The very latest in Loud Speakers, with Pleated Bronze Parchment

Diaphragm	£13 5 0
STERLING DINKIE	2 17 6
" Baby	4 15 0
" Audiovox	9 0 0

AMPLION SPEAKERS.

One of the Most Popular Speakers of To-day.

AR102 Amplion Dragonfly	£2 0 0
AR111 Amplion Junior	4 0 0
AR114 Amplion Junior de Luxe..	5 5 0
AR19 Amplion Dragon	8 0 0
AR61 Amplion Music Master ..	9 0 0



Amplion Speaker.

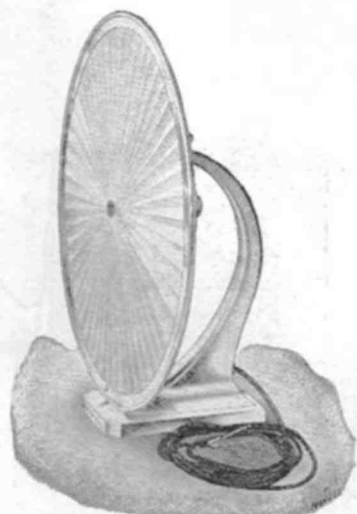

Sterling Primax.

Harringtons 

Photo and Radio
Warehouses

386 GEORGE STREET, SYDNEY (between King Street and G.P.O.);
also at Melbourne, Brisbane, Adelaide, Katoomba, Auckland (N.Z.), Wellington (N.Z.).

will be urged that such members maintain quiet hours until their transmitters have been properly adjusted.

If such amateurs refuse to give this co-operation, then the matter will be reported to the A.R.R.L. headquarters, which will ask the Department of Commerce to enforce quiet hours in their case.

Some listeners appear unable to appreciate, according to the A.R.R.L., that code interference comes from ship and commercial stations as well as amateur transmitters. Many cannot read the call of the station that is causing the interruption of their programmes, and so they are inclined to blame amateurs in their immediate vicinity, often without the slightest evidence.

It is the intention of the League in providing for the appointment of a national system of vigilance committees to give listeners an opportunity to trace the source of code interference, so that the blame in such cases may not be unjustly placed. However, if amateurs are found to be at fault, the committee will suggest adjustments for their stations in order that the trouble may be once and for all effectively removed.

One important advantage of these committees, the League believes, will be the unofficial assistance they will render the Department of Commerce's inspection division. At present the facilities of this

division are unable to take care of the many varieties of complaints made to the department.

The supervisors of radio are said to be heartily in accord with the project, inasmuch as it would have a tendency to reduce the amount of their correspondence. Through the committees, listeners will be able to have a personal investigation of interference in their neighbourhood, which would be impossible to obtain in any other way.

Committee members will assist listeners who own single circuit receivers, suggesting methods by which the sets may be changed in order to tune out objectionable interruptions.

IS THE B.B.C. OPULENT?

The recent announcement that the Post Office had handed over £800,000 to the B.B.C. between 1922 and the end of 1924 has created the impression in certain quarters that the B.B.C. is fabulously wealthy, and has a large margin for development.

This, the company state, is not the case, but that in point of fact the only profits that can be paid are restricted by Act of Parliament to 7½ per cent. on the original £60,000 capital provided by certain wireless manufacturers. The balance of the money has been absorbed by the enormous capital expenditure required in setting up 21 stations, and in creating and operating an adequate service.

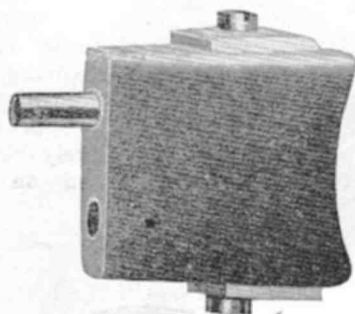

No. 223



No. 231

Component Parts for Wireless Apparatus

THESE fittings are made in the well-known "CRYSTALATE" Insulating Material, which has a 30 years' reputation behind it, and which is acknowledged to be one of the best substitutes for ebonite, and in every respect suitable for the purpose.

Catalogues and Price Lists on request from

The Crystalate Manufacturing Company Limited

**TONBRIDGE
KENT**

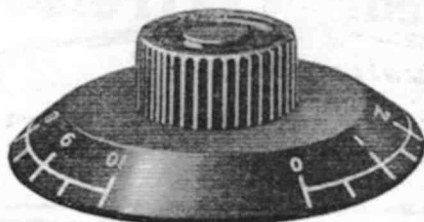

No. 237

Telephone: 33 Hadlow

Cables:

"Crystalate, Hadlow"

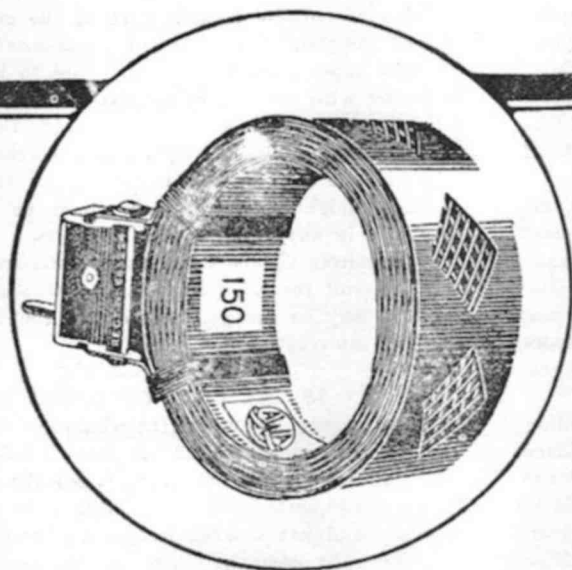

A.W.A. Honeycomb Coils

No. of Turns.	Wavelength with .001 Condenser.	Price, Mounted.	Price, Unmounted.
20	50-260	6/9	2/-
25	100-375	7/-	2/2
35	150-525	7/6	2/2
50	190-675	7/9	2/4
75	240-925	8/-	2/6
100	340-1340	8/3	2/9
150	500-1980	8/6	3/-
200	650-2675	9/-	3/6
250	725-3575	9/9	3/9
300	1050-4200	10/6	4/3
400	1600-6000	11/8	5/-
500	2000-7500	13/6	7/-
600	3000-9000	15/6	9/-
750	4000-11000	16/9	12/-
1000	4500-16000	1/-	14/-
1250	6310-18240	1/4/-	16/-
1500	7635-22210	1/8/-	18/-

At all Radio Stores

Amalgamated  **Wireless**
(Australasia) Ltd.

97 Clarence Street
SYDNEY

Collins Street
MELBOURNE



Wound on automatic - precision machinery, AWA Duolateral Coils combine high conductivity with effective insulation between turns. AWA Duo-lateral Coils are mounted on deluxe bakelite coil plugs, and a black celluloid diamond strip, and then the shoulders are specially bound with black waxed thread, which holds the coil rigidly in position.

AWA Coils are non-hygroscopic, offer very low radio-frequency resistance, and self-capacity is at a minimum. They may be used as tuning, loading, coupling, or wavemeter inductances, ensuring the highest degree of efficiency for your set.

Made in sizes to suit your requirements, each AWA Duolateral Coil is attractively boxed, and the wavelength table printed on the carton. Also supplied unmounted in red cartons.

NOTE—AWA mounted coils are supplied only in BLUE cartons.

A.W.A. Honeycomb Coils are mounted on high-grade Honeycomb coil plugs with a black celluloid diamond strip, and then the shoulders are specially bound with black waxed threads, which holds the coil rigidly in position.

A.W.A. Coils offer very low radio-frequency resistance and self capacity is at a minimum. They may be used as tuning, loading, coupling, or wavemeter inductances, ensuring the highest degree of efficiency for your Set.

Made in sizes to suit your requirements, each A.W.A. Honeycomb Coil is attractively boxed, and the wavelength table printed on the carton. Also supplied unmounted.



37/6

At all
Radio
Dealers

A Wonderful Improvement!

Western Electric

**HEADPHONES WITH
NEW COMFY PAD.**

Day after day comparisons always demonstrate the better results from Western Electric equipment. And, after all, you just pay a little more for Western Electric Headphones, but what a world of difference, compared with Headphones that are merely made to sell at a low price.

Western Electric Headphones are typical of wonderful Western Electric workmanship, which stands behind over half the world's telephones.

You get comfort, you get scientific construction. The magnetic material stands up to all conditions. Special moisture-proof cords are used. In fact, you need only examine and "listen in" with Western Electric Headphones to recognise why Western Electric is a name to trust in Radio.

Any Radio dealer will supply you with "W.E." Head Receivers. Always insist on "Western Electric."



**Before you
Expend
Money on
Radio
Equipment
Consult
Anthony
Horderns'
Wireless
Experts.**

Your inspection of the big display of everything that is new in the world of Wireless, is invited.

**(Wireless -- Second
Floor)**

**Anthony Hordern & Sons
Limited,**

Brickfield Hill, Sydney

Phone City 9119.

Box 2712 G.P.O.

(Continued from Page 10.)

emphasised the fact that the advancement of the Institute was no doubt due to 2CM, and the success of low power short wave work was entirely due to the efforts of Mr. Maclurcan. He stated that he considered that sufficient credit was not given to 2CM by the Australian public. Every country would follow in his footsteps, and the experimenter of other countries would produce the same results as 2CM, and they would be heralded throughout the entire world as being something fresh and a great advance in the science, whereas the real originator of the work, our own 2CM, would be left with his praises unsung, and his fellow-countrymen did not appreciate his great work. It is up to the Institute to forward the work put up by 2CM, and see that he received his due reward, and the public brought to know what great work is being done in their midst.

The treasurer's report was then presented. Mr. O. F. Mingay, in presenting the report, stated that it disclosed a most satisfactory state of affairs.

The report will be printed in due course and distributed amongst members, which will no doubt prove of interest to all. The work which has been carried on by Mr. Mingay and his assistant, Mr. Carter, has been of great service to the Institute, and the sincere thanks of members is due to these two gentlemen for their untiring efforts.

The ballot for the new council was next proceeded with.

While Messrs. Malcolm Perry and E. B. Crocker were acting as scrutineers, Mr. Maclurcan gave a short description of the short wave set which he had used in his recent transmissions to England during daylight. This proved of great interest to members, and many very interesting questions were asked and answered by Mr. Maclurcan.

The result of the ballot disclosed the following figures:—W. P. Renshaw, 46; H. A. Stowe, 46; C. D. Maclurcan, 45; R. C. Marsden, 33; O. F. Mingay, 30; A. H. Perrett, 28; W. H. Newman, 26; F. B. Cooke, 26; G. M. Cutts, 19; W. L. Carter, 16; W. L. Hamilton, 9; H. K. James, 6; E. P. Clarke, 6.

As there was a tie for the seventh place in the council a second ballot was taken of members present, and resulted in F. B. Cooke 15 and W. H. Newman 4. The seventh place in the council is, therefore, occupied by Mr. Cooke. It is interesting to note that, with the exception of Mr. Perrett, all of those elected are members of the old council, and, as Mr. Perrett has been actively associated with the council during the past twelve months, the result of the ballot may be taken as a vote of confidence for the work of the council during the past twelve months.

The Chairman then welcomed Mr. Geo. A. Taylor on his return from his trip abroad.

Mr. Taylor, in reply, gave a very interesting account of his journeys, particularly outlining the actual position with regard to the British Post Office and the beam system. He disclosed the fact that much misunderstanding exists as to the attitude of the Post Office, and altogether his remarks were of the most interesting and illuminating nature.

QRM.

2BB has not been working for some months, but he is still getting Q.S.L. cards.

2CM has been at it again. It must cost him a fortune for the records he breaks.

Why is it that 2JR always calls 3TM?

Mr. G. A. Taylor related the following story at the annual meeting, which is going the rounds in U.S.A.:—A prisoner was brought before the magistrate, who was a radio enthusiast.

"What is your name?"

"Sparks, sir."

"You have been charged with wilful interference. What is your occupation?"

"Radio engineer, sir."

"Seven days in a dry cell."

Mr. Todd, of Tamworth, was a welcome visitor at H.Q. this week.

Club Notes

THE LEICHHARDT AND DISTRICT RADIO SOCIETY.*

Members of the Leichhardt and District Radio Society rolled up in excellent force to the 126th general meeting held at the club room, 176 Johnston Street, Annandale, on April 14th.

The main business of the evening was the delivery by Mr. R. C. Caldwell of the sixth lecture of Syllabus No. 3, under the title "Problems of Fading Signals," and the subject proved very interesting to all present. The lecture consisted principally of an expounding by Mr. Caldwell of the theories of that eminent authority, Sir Oliver Heaviside, and the explanation of the action of the "mirror layer" and of "earth" and "sky" waves proved very interesting, and provided much material for useful discussion at the conclusion of the lecture, which was followed by a hearty vote of thanks to Mr. Caldwell for his efforts on behalf of members.

Next Tuesday evening the society will hold its 128th general meeting, when a visit will be paid to

RADIO RADIO

Wireless Dealers Only Supplied.

Our new 120 page Illustrated List of Radio Parts now ready, Showing Trade and Retail Prices. Copy sent on application. COMPLETE SETS AND COMPONENT PARTS.

We were one of the very first Wholesale Factors of Radio, and to-day hold the largest stocks of Wireless Goods in the British Empire.

Staggering Prices — Huge Stocks — Get to Know Us — It will Pay you.

Wireless Traders order from us. We have a large Export Department, and know how to deal with your Indents. To prevent delay goods can be ordered through London Merchants or if ordering direct should be accompanied by 25 per cent. deposit, balance at Sight-Draft.

Buy from an Established House.

Please Note — Wholesale Only
HOBDAV BROS. LTD. (Dept. T)
21, 23, 25 and 27 Great Eastern Street
LONDON, E.C.2
Cables: "Yadboh," Finsquare, London.
A.B.C. 6th Edition.

members by Mr. A. G. McFarlane, of the "Exide" Battery Service Station, for the purpose of delivering lecture No. 7 of the syllabus. The subject chosen for the occasion is "Batteries," and in the capable hands of Mr. McFarlane should prove of exceptional interest to all. A good attendance of members is anticipated.

At the following meeting, to be held on May 5th, the 31st monthly business meeting will be held, when applications for membership will be dealt with.

Experimenters and others interested in the work being carried out by the society are invited to address inquiries to the hon. secretary, Mr. W. J. Zech, 145 Booth Street, Annandale.

CONCORD RADIO CLUB.*

The next weekly meeting was held at the club rooms on Thursday, 16th. Proceedings were opened by the president, Mr. J. V. Stevenson, at 8.30 p.m. Owing to the American tests the attendance left much to be desired, although one prominent member came to light after an absence of several weeks. The presence of this member and all other members is particularly requested at all meetings. Please note. The poor attendance was regretted, more especially owing to the fact that "Insulator," of "Wireless Weekly" fame, favoured us with a visit. The subject taken was "Circuits," and a long dis-

It's EDISWAN*So It's Reliable*

"Radiophone." The mere fact that it's an "Ediswan" product is sufficient guarantee as to the quality of the workmanship and parts used.

The Radiophone surpasses many of the more expensive 4 Valve sets offered, for long-range reception and selectivity.

Let us demonstrate it to you.

Edison Swan Electric Co. Ltd.

58 Clarence Street, Sydney

368 Little Collins St., Melbourne 32-34 Adelaide St, Brisbane



4 Valve Long Range

RADIOPHONE

Separate terminals are supplied for 'phones and loud speaker. A switch provides for the use of 2, 3, or 4 Valves. Aerial circuit may be earthed by means of switch, the batteries at the same time being disconnected.

Sockets for loading coils are provided to receive wave lengths over 500 metres.

Leading Dealers Stock Ediswan Equipment

cussion followed on the merits and demerits of certain "hook-ups." Mr. Hamilton also brought along his two-stage distortionless amplifier, which is a very neat piece of apparatus and was much admired. The convenience of such an amplifier to the experimenter, whose various sets are usually in a stage of alteration, can readily be seen, and the expense is very

small compared with the return provided. After a vote of thanks to Mr. Hamilton the meeting closed at 10.40 p.m.

Several members are very inquisitive as to the identity of the club officer who conducted such a lucrative business at the R.A.S. Show and what the business consisted of. Perhaps he will oblige?

Wireless at the R. A. Show

VERY great interest was displayed by visitors at the Royal Agricultural Show, Sydney, at the exhibition of radio apparatus displayed by Amalgamated Wireless (A/sia), Ltd.

Not only was the stall spectacular in appearance, but it covered one of the most comprehensive and remarkable exhibitions of broadcast receivers for listening in presented in Australia.

For the first time there was displayed the Radiola Super, probably the most efficient and in appearance the most pleasing set yet manufactured in Australia. The Radiola Super is a 6-valve receiver, incorporating the latest and most advanced

ideas in receiver design since the invention of wireless. It is entirely self-contained, and operates without any external aerial or earth. It represents a veritable triumph of radio research and engineering, and meets every requirement of Australian broadcasting. By means of an entirely new invention it provides in a superlative degree super-sensitivity, super-selectivity, reception and reproduction.

In selectivity the Radiola Super reaches the theoretical limits of the science. It may be used in close proximity to powerful broadcast stations, and yet it will easily tune them out in favour of the more distant stations. It is beyond comparison with

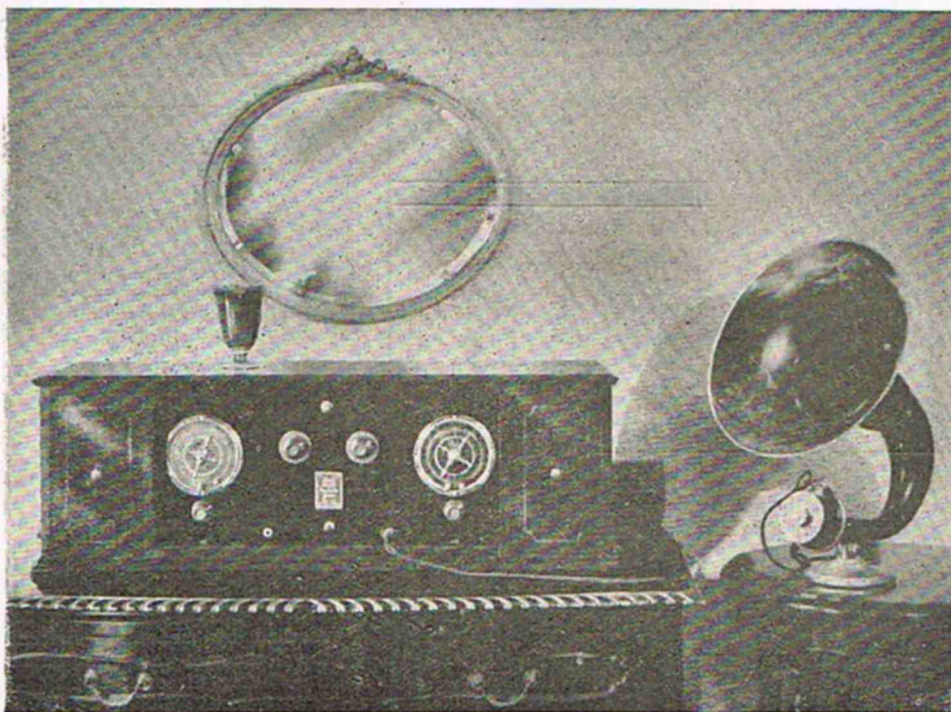

The Radiola Super Table Type.

any existing receivers, and in general comes very close to being the ultimate in broadcast reception.

The Radiola Super is featured in three models—the Table type, the Sheraton Cabinet model, and the Sports model—all of which are manufactured at the radio electric works of Amalgamated Wireless (A/sia) Limited.

In tuning, but two controls or "station selectors" are employed. Each of these is vernier controlled, and cardboard discs are provided, which are clamped in place over the tuning dials. As each station is first tuned in, a mark is made on the disc where the pointer comes to rest, and the station's call letters are then written in at that point. In tuning a Super, the various stations are picked up at exactly the same spot each time, therefore any inexperienced person is able to operate the Radiola Super with ease and facility.

The cabinet container for the table model is constructed of beautifully finished mahogany, with a leather handle on the top for carrying from place to place. Since there are no external connections, the instrument can be moved from one portion of the house to another with little trouble. The mechanism lies behind the control panel, and ample space is provided in the two end compartments to accommodate the batteries. The loop aerial is concealed in the cabinet.

The Radiola is non-radiating, and will not interfere with any other receiving set, however close it may be.

The "volume control" knob is a new feature, in that it permits regulation of volume without re-tuning. Except for the loud speaker, the set is entirely self-contained. Dry cells can be used satisfactorily, and are supplied with the set as standard equipment. Should it be desired to use accumulators, sufficient room is provided in the cabinet for the housing of same.

For those who desire to take a receiver away with them in a car or a yacht, the portable Radiola Super should make an especial appeal. It is divided into two units, one the receiver proper and the other the battery cabinet. By means of a special swivel arrangement the upper cabinet revolves on the lower one, and by this means the necessary directional effect is obtained. The covering is of black leather, and will stand a fair amount of rough usage in travelling.

Particular interest was evinced by visitors in the model of a Radiola IV, encased in a glass cabinet. The whole of the mechanism is open to view, and the excellent radio engineering work thereby displayed was the subject of much comment.

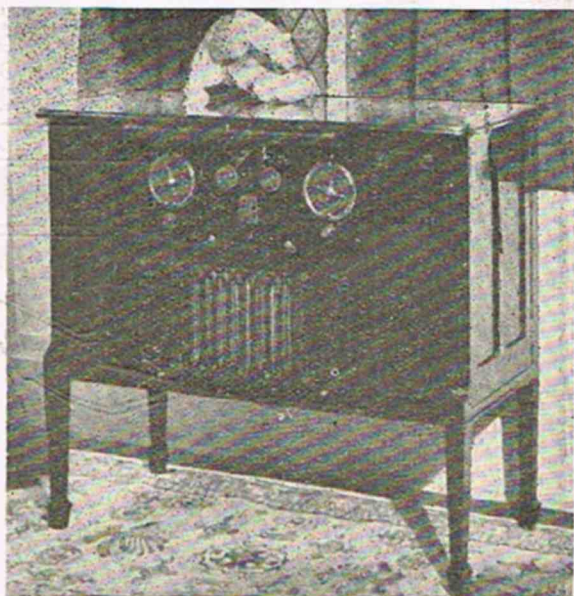

Sheraton Cabinet Model.

An effective exhibition was also made of amplification loud speakers. These are made in many models and at a price to suit any purse.

A $\frac{1}{2}$ k.w. combined radio telephone transmitter and receiver, specially adapted for communication between isolated inland centres, and also for inter-island use, was on view. This equipment embodies all the latest improvements in design and manufacture, making for stability, combined with simplicity of operation.

Besides the above, there were on view models of the Radiola Crystal, Radiola II and Radiola III, while the famed Marconiphone models V2 and V3 were featured.

Hard luck has met Mr. P. J. Browne (A2JB), whose phone transmissions were becoming quite familiar to listeners-in over a very wide area. In the company of W. Cottrell (A2ZN) he carried on business as a radio dealer until he received a tempting offer to go to America in order to compete in various speed races. On the eve of his departure he was taken suddenly ill, and was operated upon hurriedly at Helenie Private Hospital, Church Street, Randwick. Fortunately he is now making satisfactory progress, but has been forced to cancel his American engagement. As soon as he is fully recovered, Mr. Browne proposes re-entering the radio field, and within four or five weeks A2JB should be again on the air.

*No more heavy
service bills*

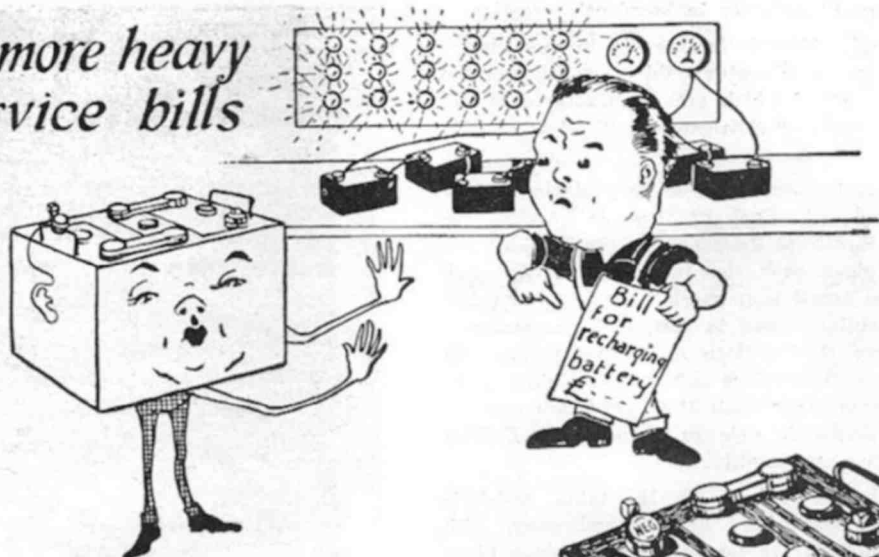

It holds its Charge

The biggest problem of the Radio "A" Battery to the average amateur is the constant carrying backwards and forwards for recharging.

You can depend on

UNITED RADIO "A" BATTERIES

To give the full rated ampere hour capacity under the most exacting conditions. Service station bills for recharging will be appreciably less, and you will enjoy uninterrupted use of your set — when you instal a UNITED BATTERY.



UNITED RADIO BATTERIES

are specially constructed for United Distributors Ltd., by the Clyde Engineering Company Ltd., and conform to the very highest standards in quality of materials, soundness of construction, and adaptability to radio work.

PRICE LIST.

S 5—Capacity 6 volts	44 amp. hours	£4 0 0
S 7—Capacity 6 volts	66 amp. hours	£4 15 0
S 9—Capacity 6 volts	88 amp. hours	£5 5 0
C 9—Capacity 6 volts	120 amp. hours	£6 6 0
C11—Capacity 6 volts	150 amp. hours	£7 7 0
C13—Capacity 6 volts	180 amp. hours	£8 8 0

Ask your Dealer for "United" Radio Batteries.

United Distributors Limited

72 CLARENCE STREET,
SYDNEY,
Queen Street, Perth.

(Wholesale Only)

592 BOURKE STREET,
MELBOURNE.

Cr. Jervois Quay & Harris Street, Wellington.

Use Clyde Storage Batteries for Radio, Motor Car and Home.

CLIX The Electro Link with 159 Uses.

TRADE MARK

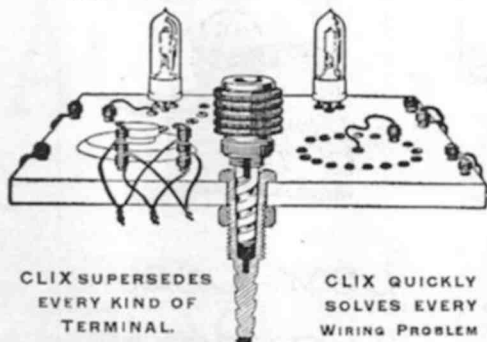

CLIX SUPERSEDES
EVERY KIND OF
TERMINAL.

CLIX QUICKLY
SOLVES EVERY
WIRING PROBLEM

CLIX Combination Plug-Socket is the most ingenious and efficient contact ever invented.

CLIX phenomenal and world-wide sales are convincing proof of their popularity and merit.

CLIX Illustrated Leaflet describes many applications
CLIX are patented all over the world;

Write for list to-day—Few Agencies still available.

AUTOVEYORS LTD.

RADIO ENGINEERS, CONTRACTORS & EXPORTERS

82-84 VICTORIA-ST., WESTMINSTER, LONDON

Telegrams: Autover,
Sowest, London.

Trade Terms on
Application

The

WIRELESS EXPORT TRADER

Indispensable to TRADERS
throughout the World.

It is designed to assist Overseas Traders who wish to purchase in the British Wireless Markets, showing them how, when, and where they may buy most economically. Authentic reports are given of tests made on new British Sets and Components, and information on a wide range of subjects of the utmost importance to the trader are a feature of the Editorial columns.

The advertisement pages of "THE WIRELESS EXPORT TRADER" form an invaluable buyers' reference guide to British Wireless Productions.

Let us send you

A FREE SPECIMEN COPY

Forward your trade name and address to

THE WATERGATE PRESS LTD.,
19 Surrey Street, Strand, London, W.C.2, England.

Publishers also of "THE WIRELESS TRADER"—
the Trade Journal of the British Wireless Industry.

CLARKE & HAGBLOM

Products of

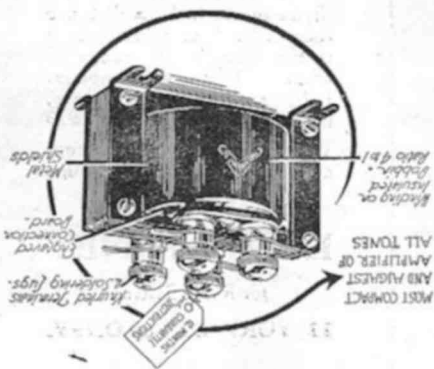

RADIO PRODUCTS

ADVANCE

Father Time tells —
Quality is Economy.



PROCRASTINATION

IS THE THIEF OF TIME !

WHEN you keep putting a thing off, somehow it never seems to get done.

How often have you missed a copy of "Wireless Weekly" just because you forgot to call at the bookstall before they were sold out?

"Wireless Weekly" keeps you in touch with everything wireless.

Its columns of reading matter gives you information you can get from no other paper. Its advertisement columns keep you informed of all the latest apparatus arriving on the market.

Let it keep you up to date. Get it regularly by mail.

"SUBSCRIPTION FORM."

To the Editor,
"Wireless Weekly,"
12/16 Regent St., Sydney.

Please forward me for.....
months "Wireless Weekly," for which I
enclose.....plus exchange of
country cheque.

.....192.....

Signed.....

Address.....

Annual Subscription, 13/-, post free.



Low-Loss SETS

for
Overseas
Reception.

This Winter, broadcasting from overseas will become a regular feature of wireless programmes.

Keen Radio enthusiasts will be endeavouring to out-do each other in the matter of distance reception and for successful results Low-Less Sets excel.

David Jones' have specially designed a Low-Less Set, which has met with unqualified success in long distance reception. A pleasing feature is the wave-length range of from 0 to 450 metres. Price, complete with valves, batteries and 'phones, £23 Without accessories, except coils. Price ... £14/10/-.

DAVID JONES'

for Radio Service

22 YORK ST., SYDNEY.

Phillips Valves, 12/6.	1		2	3	4	5	6	7	8		9	Panel Mounts, 1/6.
Jefferson 41 Transformers, 24/-.			10									3in. Dials, 1/6.
Jefferson Star, 19/-.	11	12		13							14	2 Coils Mount, 5/-.
Radiotron 201a Valves, 21/-.	15		16		17					18		Porcelain Sockets, 2/9.
Brandes Phones, 26/-.		19							20			Ormond .001 Vernier Con- denser, 16/6.
Pico Phones, 20/-.		21						22				Bakelite Knobs, 9d.
Buck's Trans- formers, 12/-.	23								24			Bradley Stats, 12/6.
D.V.3 Valves, 21/-.	25			26		27		28		29		Bradley Leak, 12/6.
Coil Mounts, 1/6.	30			31				32		33		Resin Solder, 2d. per foot.
			34						35			
	36											

Price's Radio Den Cross-Word Puzzle!! I Lead, Others Follow

1st Correct Solution opened—Radio Goods valued at £2/2/-.

2nd Correct Solution opened—Radio Goods valued at £1/1/-.

Entries close 15th May, 1925, to enable Country and Interstate Subscribers to compete.

Special Prize: Radio Goods valued 10/6 for the competitor living the farthest from Sydney.

Address your Solutions: Price's Radio Den, Cross-Word Competition, 220 Oxford St., Woollahra, N.S.W.

HORIZONTAL

1. A broadcasting term.
10. A fish.
11. One of the United States (init.).
13. Silent.
14. Preposition.
15. To lean from the vertical.
17. A married woman.
18. Printers' measure (plural).
19. A well-known ear (init.).
20. Part of the verb to be.
21. Feared by the underworld (init.).
22. Part of the verb to be.
23. Printers' term (init.).
24. Person opposed to liquor (init.).
25. Little (obsolete).
26. Animal.
28. To fell.
30. Preposition.
31. Played on Uncle George's pianola.
33. Egyptian Deity.
34. Units of electrical current.
36. Earthly.

VERTICAL

1. Before connecting your "B" Battery on completing set.
2. Exclamation.
3. Man's name (abbrev.).
4. Term used in card game.
5. On speaking terms with Uncle George.
6. A bird.
7. A rebuke.
8. Telephone transmitters (init.).
9. In code.
12. Path of an electrical current.
14. For measuring current.
16. The King of Radio Dealers.
18. One of the terminals of your receiver.
25. A unit of electrical power.
26. To gull.
27. Girl's name (abbrev.).
29. A defence.
31. Sentence denoting annoyance used by wireless fans (inits.).
32. An Indian measure of weight.
35. Syllable applied to seventh tone of any Major Diatonic Scale.

COL-MO

READY TO WIRE SETS

Genuine Radio Sets that will work

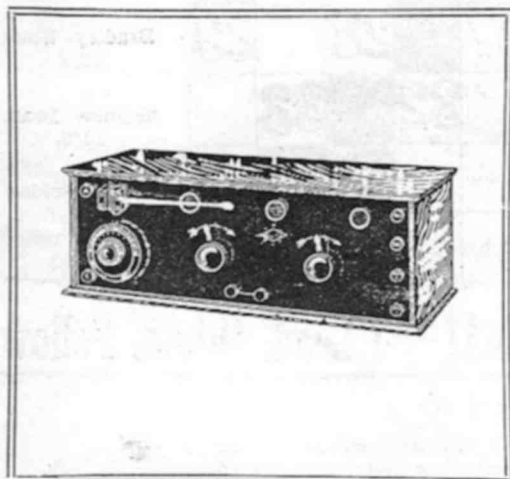

Our Ready-to-Wire Sets are complete with wiring diagrams.

No previous experience necessary to wire a COL-MO Ready-to-Wire Set.

Wiring takes Time and Time is Money

DO THE JOB YOURSELF AND SAVE MONEY

ONE VALVE SET:
Complete with Cabinet
£2/15/0

TWO-VALVE SET:
Complete with Cabinet
£4/10/0

THREE-VALVE SET:
Complete with Cabinet
£6/5/0



COLVILLE-MOORE

WIRELESS SUPPLIES, LIMITED.

10 ROWE STREET (HOTEL AUSTRALIA) SYDNEY

COL-MO LITTLE GIANT SETS

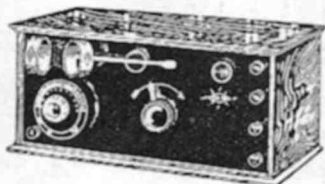

The Little Giant Sets are sold complete with all accessories, including aerial wire. The three valve Little Giant is complete with all accessories and Loud Speaker.

One Valve Set	£7/10/-
Two Valve Set	£12/10/-
Three Valve Set	£24

THE LITTLE GIANT ALWAYS LIVES UP TO ITS NAME. A GIANT IN TONAL QUALITIES, EFFICIENCY AND SIMPLICITY OF OPERATION ARE FEATURES NOT SURPASSED IN LARGER HIGHER-PRICED INSTRUMENTS.

Col-Mo Low Loss Condensers

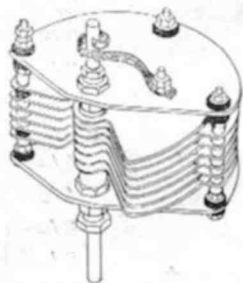

It is interesting to note that at last a GROUNDED ROTOR brass plate condenser of the LOW LOSS type has been constructed in Sydney. The construction is entirely of brass, having brass ends common to the Rotary plates, and electrically connected thereto by a pig-tail connection of brass flex. Absolutely no body capacity effects are possible with this condenser for in addition to the earthed end plates, the fixed plates are further screened by two extra Rotary plates. Designed on a straight line principle to facilitate accurate tuning.

COLMO LOW LOSS CONDENSERS, capacity only .00025
16/- and 22/6

Colville - Moore
Wireless Supplies, Limited
10 Rowe Street (Opposite Hotel Australia) Sydney

PHILMORE

RADIO APPARATUS

		Retail.
Contact Points, with Hex Nuts, unassembled	.. per doz.	6d.
Switch Stops, with Hex Nuts, unassembled "	6d.
Binding Posts, Nickel-plated, unassembled "	2/-
Insulated Knob Binding Posts, assembled "	3/9
Initialled Binding Posts (8 on a card)	.. card	3/-
Brass Hexagon Nuts, 6/32 per doz.	3d.
Sliders, Brass, $\frac{1}{4}$ in. each	1/-
Antenna Insulators "	1/-
Switch Levers "	1/3
Inductance Switch "	5/6
Insulated Dials, 2in. "	1/9
Insulated Dials, 3in. "	2/-
V. T. Sockets, moulded "	2/6
V. T. Sockets, metal shell "	3/-
U.V. 199 Sockets "	2/9
Rheostats, mounted base, 6 ohm "	3/-
Rheostats, mounted base, 30 ohm "	4/-
Potentiometer, mounted base, 240 ohm "	4/9
Potentiometer, mounted base, 400 ohm "	5/-
Glass Enclosed Detector, unassembled "	3/-
Crystal Detector, Open Type, unmounted "	1/3

FROM ALL DEALERS.

PACIFIC ELECTRIC CO. LTD.

87 CLARENCE STREET, SYDNEY

Phone B 5891

Sole Australian Distributors

Distance and Volume

Announcing

that the Price of Radiotron Valves

U.V. 199 U.V. 200

U.V. 201a W.D. 12

has been Reduced to

25/- each

The word "Radiotron" on any valve is synonymous with high operating efficiency, low consumption, and, above all, long life.

Radiotron U.V. 199 is of the Dull Emitter type and operates with a filament current of .06 of an ampere. It is an efficient detector and audio-frequency amplifier.

Radiotron U.V. 200 embodies all the characteristics necessary for a faultless detector.

Radiotron U.V. 201a is an improved high vacuum valve, particularly suited for audio amplification. Its current consumption is only .25 amperes.

W.D. 12 is designed for operation off a single dry cell, the voltage being 1.5 and the amperage .25.

Amalgamated  Wireless
(Australasia) Ltd.

97 Clarence Street,
Sydney.

Collins House, Collins Street
Melbourne

Radiotron

Amplification Factor 20

**Resistance Capacity Coupling
for sweetness of tone.**

DE 5 B Geco valve

The critical broadcast enthusiast who desires better tone reproduction and a simplified arrangement can now install Resistance Capacity Coupling without any sacrifice of volume.

The GECoVALVE DE5B, with the remarkable amplification factor of 20, is designed with the specific object of confining the maximum of the amplifying process to the valve itself.

Resistance Capacity Circuits using DE5B GECoVALVES entail no sacrifice of volume or efficiency, and are infinitely superior in every other respect.

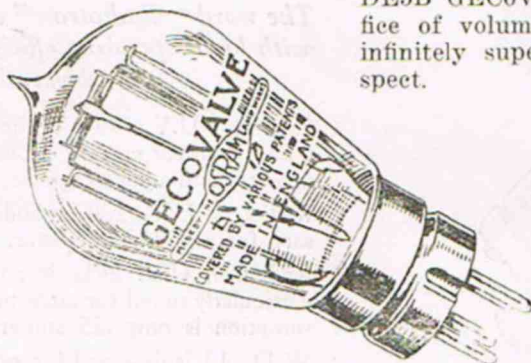

GECoVALVES are manufactured at the Osram Lamp Works, England—the largest works of its kind in the British Empire. Their manufacture is directed from the Research Laboratories of the General Electric Co., Ltd., by valve experts, who are also experts in the design of wireless sets.

Characteristics:

Filament Voltage - 5
 Filament Current 22amps
 Plate Voltage 100-120
 Impedance 30,000 ohms
 Amplification Factor 20

PRICE - 32/6

Obtainable from All Reliable Wireless Dealers

British General Electric Co. Ltd.

154 CLARENCE STREET, SYDNEY, and at
 MELBOURNE, ADELAIDE, PERTH, NEWCASTLE