

# WIRELESS WEEKLY

Registered at the G.P.O., Sydney, for

transmission by post as a newspaper.

VOL. 5. No. 25.

FRIDAY, APRIL 17, 1925.



Made in England  
NEW SYSTEM  
**True Music Receiving Set**

WITH  
Crystal Detector and  
2 Valve Amplification

Complete : **£18 5s. 0d.!**

*Price Includes:*

True Music Loud Speaker  
Cossor Valves  
New System Headphones  
Exide "A" Battery  
H. T. Battery  
Aerial Accessories

NEW SYSTEM TELEPHONES PTY. LTD.

780 CASTLEREAGH ST.  
SYDNEY.

25-27 QUEENS BRIDGE ST.  
MELBOURNE

Phone : M 3230

CENTRAL : 11110

3 VALVE RECC.  
(NEUT.) UNIQUE.  
**FEATURE:**  
REIN. ALL WAVE R.  
ADAPTED FOR L.W.  
NOTES.   
A

Distortionless  
Amplifier

VL



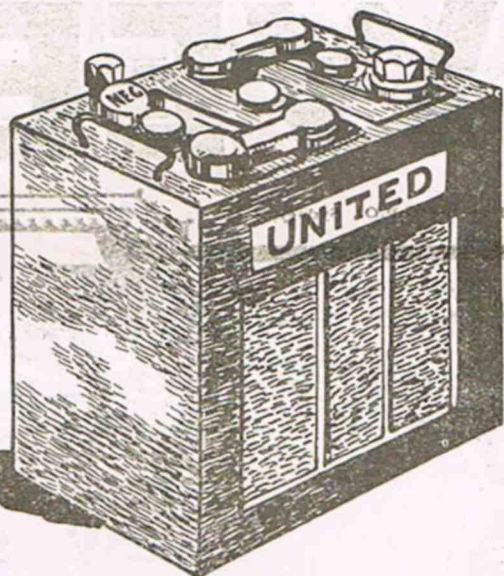
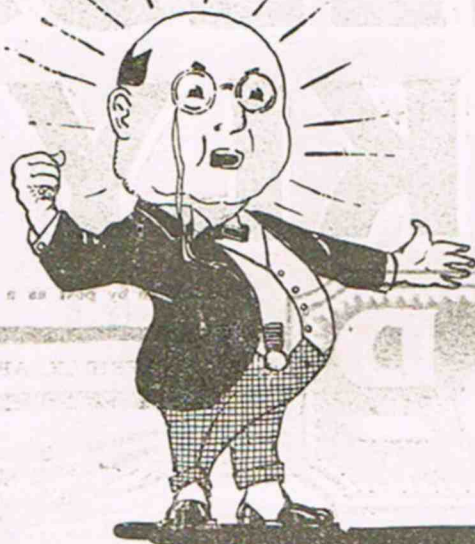

*Ample Capacity!  
Minimum loss of charge whilst standing idle!!  
Uniform flow!!!*

You can depend on getting the full rated ampere-hour capacity from a United Radio Battery. This means uninterrupted use of your radio set and less inconvenience in carrying batteries backwards and forwards for recharging.

The man who uses his set comparatively infrequently will welcome the special construction of United Batteries, which ensures minimum loss of charge whilst standing idle, and the lead covered terminals which prevent corrosion.

### UNITED RADIO BATTERIES

are built for solid service by the Clyde Engineering Co., Ltd., specially for United Distributors Ltd., and are fully guaranteed to maintain constant voltage and uniform flow of current.

#### PRICE LIST.

S5.	Capacity 6 volt.	44 amp. hours	£4 9 0
S7.	Capacity 6 volt.	66 amp. hours	£4 15 0
S9.	Capacity 6 volt.	88 amp. hours	£5 5 0
C9.	Capacity 6 volt.	120 amp. hours	£6 6 0
C11.	Capacity 6 volt.	150 amp. hours	£7 7 0
C13.	Capacity 6 volt.	180 amp. hours	£8 8 0

Ask your Dealer for "United" Radio Batteries.

USE CLYDE STORAGE BATTERIES FOR RADIO, MOTOR CAR AND HOME.

## UNITED DISTRIBUTORS LIMITED

72 Clarence Street,  
Sydney.

592 Bourke Street,  
Melbourne.

Queen Street,  
Perth.

Cr. Jervois, Quay and  
Harris St., Wellington.

# The Fifth CULLEN Circuit

YOU HAVE MY WORD FOR IT

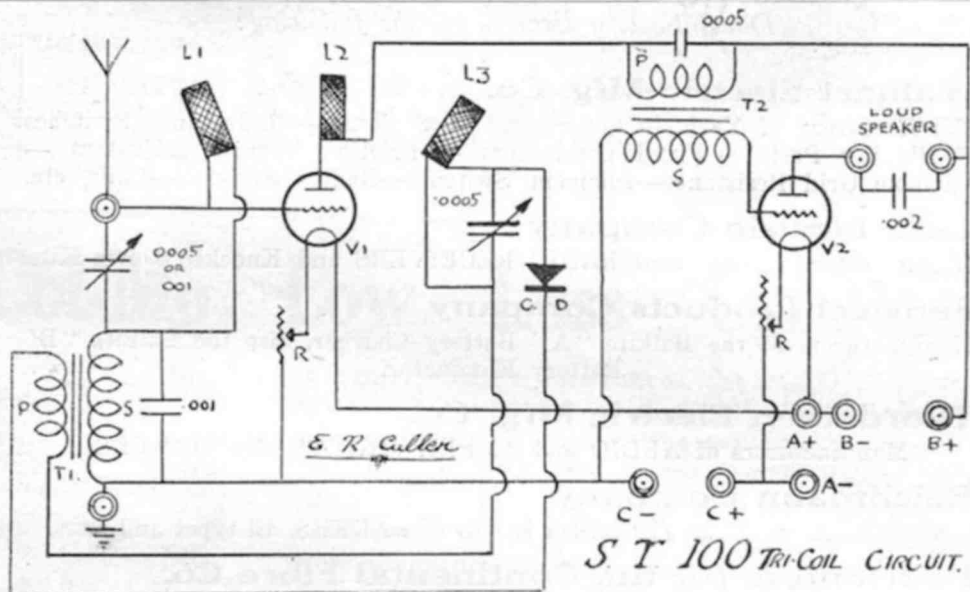

**W**ONDERFUL as the ST 100 receiver is, it has one disadvantage it is not as selective as could be desired. To overcome this difficulty the circuit above was devised.

ST 100-ites who wish to convert their sets will notice how very easily this may be done. Provision has been made for a Grid Bias battery (C battery) to both valves.

Only the best quality materials are here quoted. Many people strike failure in reflex sets through employing inferior apparatus. The valves to be recommended are UV201A's which now sell at 25/- each. True Blue and A.P valves have functioned splendidly. A high plate voltage, usually 100 volts, will be found best as both valves are amplifiers. This circuit is stable, one adjustment of the coupling of the coils being sufficient to stop self oscillation. Try it.

## E. R. CULLEN

RADIO AND ELECTRICAL STORE  
Tel. City 869 & 2596 96 BATHURST STREET

### PARTS REQUIRED

- 1 Panel, 18 x 9 x 3/16.
- 1 3 Coil De Luxe Holder... 15/6
- 2 Jefferson Star Transformers, £2/5/-
- 2 .0005 Master Variable Condensers, with Dials... £2/10/-
- 2 Master Valve Sockets... 12/-
- 2 Nutmeg Rheostats and Dials, 13/4
- 1 Cullenola Crystal Detector.. 5/-
- 10 Terminals... 3/4
- 1 .001 Wetless Condenser... 1/6
- 1 .0005 Wetless Condenser... 1/6
- 1 .002 Wetless Condenser... 1/6
- Busbar, Screws, etc... 3/-

# JUST IN TIME

*for the big*

## EASTER SHOW

*Direct Factory Branch for the following:*

### **Walnat Electric Mfg. Co.**

Manufacturers of Variable Condensers — Sockets — Inductance Switches — Binding Posts — Fixed Condensers — Friction Vernier Adjusters — Variable Grid Resistance—Filament Switches—Radius Switches—Coils, etc.

### **Case Electric Company**

Manufacturers of the latest RADIO RECEIVERS and Knocked Down Kits.

### **Fansteel Products Company**

Manufacturers of the Balkite "A" Battery Charger, also the Balkite "B" Battery Eliminator.

### **Thordarson Electric Mfg. Co.**

Manufacturers of AUDIO and AMPLIFYING TRANSFORMERS.

### **Reichmann Company**

Manufacturers of the THOROLA LOUD SPEAKERS, all types and sizes.

### **Distributors for the Continental Fibre Co.**

Manufacturers of Bakelite and Fibre Sheet — Tubes — Rods — all sizes — all shapes and specialities. We service your Bakelite, cut—drill—sand—punch and engrave to your specifications.

**RETAILERS DEALERS JOBBERS WHOLESALERS**

*Let's get together and have another Radio Year*

## **Commonwealth Radio Company**

**200 Castlereagh Street, Sydney**

*(Fifth Floor)*





# RADIO — for — WINTER

How are those long, dreary winter evenings going to be spent if you have no Radio Set?

The pleasure that your neighbours are deriving from their Sets should be sufficient inducement for you to instal that long-intended Crystal Set or Valve Set ready for the new season's wave of Radio enthusiasm. If you already have a Set that you intend improving, now is the time to procure those necessary fittings that will ensure greater delight and more positive satisfaction in the evenings to come.

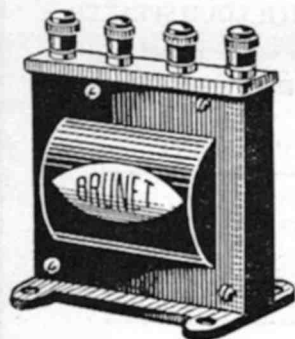

## YOU NEED BRUNET Transformers

The Brunet Transformer at 21/- is a remarkably fine investment for any Valve Set. It increases the volume of sound reception, and every little sound wave is reproduced in a manner identical with the way in which it was transmitted from the broadcasting station. It is of proved reliability, and, at 21/-, we say again, is marvellous value.

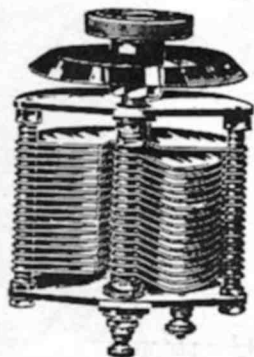

## Ormond Condensers

will give **BETTER** Results

THE PRICES ARE:

Duo Anode, .00025	20/6
Plain, with Knob and Dial.	
.0002	9/-
.0003	10/-
.0005	10/6
.00075	12/6
.001	13/6
Vernier, with Knob and Dial.	
.00025	11/6
.0003	12/6
.0005	13/6
.001	17/-

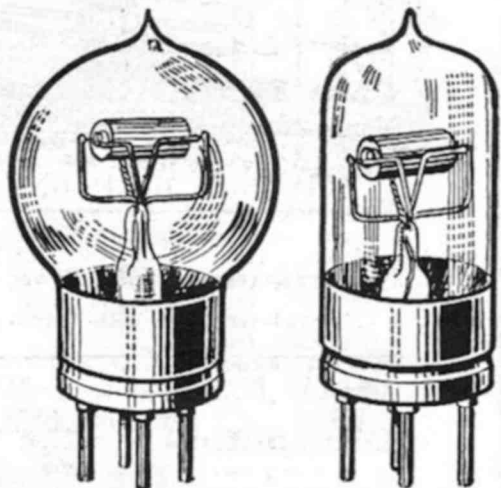

## General Reduction in RADIO VALVES !

Corbett Derham announce an all-round reduction on Valves, and the Radio public will welcome this important news, because it means that more Equipment can be procured for the same outlay.

**DUTCH VALVES**, as illustrated.

D. Detector	9/6
E. Amplifier	9/6

**PHILLIPS VALVES.**

D1, D2, D4, D5	13/-
E Amplifier	13/-
D6 Double Grid	18/-
H2 Dry Cell	20/-
E6 Dry Cell Double Grid	30/-

**RADIOTRON.**

UV 199, AW 99	25/-
UV 200, UV 201A	25/-
Other makes also reduced.	

# CORBETT DERHAM & CO. PTY., LTD.

231 CLARENCE STREET, SYDNEY.

MELBOURNE, SYDNEY, BRISBANE, ADELAIDE, LONDON, NEW YORK, CHICAGO.

REPRESENTATIVE FOR QUEENSLAND: WALTER F. DENBY, 80 EAGLE ST., BRISBANE.

## LEVENSON'S EASY TERMS

# The most modern 5-valve Set

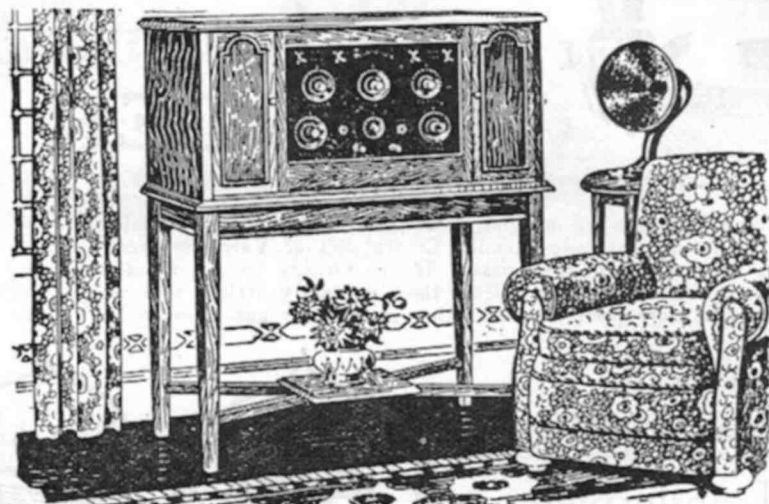

### Needs No Aerial

We will give 12 month's free service and attention, also recharge wet batteries free for 12 months. Guarantee to receive all stations in Australia, including Melbourne, whilst Farmers are Broadcasting.

Installed FREE

Price complete, £95  
WITH LOUD SPEAKER

We will be pleased to give private demonstrations.

### WHY NOT HAVE ONE INSTALLED ON TIME PAYMENT

- 1 Valve Set (complete with Valve and Batteries from . . . . . £7/10/-
- 2 Valve Set (complete with Valves and Batteries) from . . . . . £17
- 3 Valve Set (complete with Valves and Batteries) from . . . . . £25

All American Transformers, 3 to 1, 25/-; 5 to 1, 27/6. A.P. UV199 Valves, 21/- each. A new shipment has just arrived of JEFFERSON TRANSFORMERS.

### AMERICAN BRAND 100 to 1 RATIO VERNIER LOW LOSS CONDENSERS.

.0005 . . . . .	32/6
.001 . . . . .	37/6
Southworth Vernier Condensers.	
.001 . . . . .	25/6
.0005 . . . . .	21/6
.00025 . . . . .	19/6

### Parkes English Condensers with Vernier

Capacity.	Vanes.	Spacing.	Price.
.001 . . . . .	43 . . . . .	.092 . . . . .	18/-
.00075 . . . . .	33 . . . . .	" . . . . .	16/6
.0005 . . . . .	23 . . . . .	.092 . . . . .	14/9
.0003 . . . . .	15 . . . . .	" . . . . .	13/6
.0002 . . . . .	11 . . . . .	" . . . . .	12/6
.0001 . . . . .	7 . . . . .	" . . . . .	11/3

Mounted "Gold" Crystal 2/- "Winchester" make Pocket Torches from 9/6. 50 candle power Electric Lamps, 1/6 each.

4,000 Ohm Headphones . . 18/9

Sole agent for N.S.W.

Whisker. Latest Startling Discovery in Radio for Reflex Work.  
Super-Sensitive T.N.T. High Power Radio Crystal complete with Desert Cactus Cat.  
Only known Wireless Crystal of its kind in the World — each 2/-.

**SETS ON TIME PAYMENT from 2/6 per week**

Sub-Agents Wanted to Distribute Parkes' Condensers and T.N.T. Crystals.

## LEVENSON'S WIRELESS, 244 Pitt Street

Phone City 4480

Near Park Street.



We have pleasure in Announcing the arrival of  
Fresh Stocks of

# ACME LOW LOSS Condensers

AT ALL **48/6** GOOD STORES

JUST ARRIVED

## "BLACK BEAUTY" SPEAKERS

These Speakers are offered with the conviction that they  
are BETTER VALUE than any other Loud Speaker  
Regardless of Price

Everywhere **75/-** Everywhere

WE HAVE JUST OPENED UP STOCKS OF

## E. T. Flewelling Low Loss Condensers

MADE BY THE  
FOREMOST LOW  
LOSS AUTHORITY

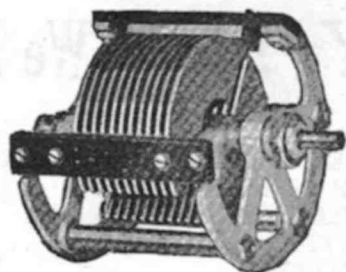

IN THE  
UNITED  
STATES

Have you entered for the "SCIENTIFIC" HEADSET COMPETITION YET ?

DEFINITELY CLOSES APRIL 18th, 1925

Wholesale  
Only

**P. H. CLARK LTD.**

Phone: City 8469  
Box 914, G.P.O.

38-44 CARRINGTON ST., SYDNEY

Our Agents in other States:

VICTORIA: W. N. Bartholomew, 380/382 Flinders Lane, Melbourne.

QUEENSLAND: Colin Campbell, "City" Buildings, Edward St., Brisbane.

SOUTH AUSTRALIA: Cedric Wright & Co., "Hayward" Buildings, Charles St., Adelaide.

ACME ——— WALNART ——— HILCO ——— LINCOLN LOOPS, Etc.

# BUILD YOUR OWN

## 3 VALVE SET

By using the Ready Cut and Drilled Panel and Complete Set of Parts for Building

### THE VOLMAX "KWYT+SI" SET

You will get Full Loudspeaker Volume, or phone strength if desired with pure music  
PRICE of complete set of parts, including drilled and engraved panel, polished maple baseboard, Vernier Condenser, 2 coil fitting, 4 coils, Grid Condenser and leak, Valve Sockets, Transformers, Jacks (3), Rheostats, etc.

**£8/5/0**

See one in operation at

## WIRELESS SUPPLIES LIMITED

21 Royal Arcade, Sydney

Phone M 3378

# OH BOY !! "We Do Put It Over"

RADIOTRON 201a VALVES (Bakelite Base) . . . . .	S	d
JEFFERSON TYPE 41 TRANSFORMERS . . . . .	21	0
JEFFERSON "STAR" TRANSFORMERS . . . . .	24	0
PHILLIPS BRIGHT EMITTERS (All types) . . . . .	19	0
PHILLIPS B.2. DULL EMITTERS . . . . .	13	6
BRANDES MATCHED TONE HEADPHONES . . . . .	20	0
PICO HEADPHONES . . . . .	26	0
	20	0

DE FOREST DV3 VALVE, 21/-.

*All the above are guaranteed genuine and true to label. Do not be misled—We are trying—in spite of ridiculously high license fees, to give you radio at reasonable prices—Help us.*

## Price's Radio Den

220 OXFORD STREET, WOOLLAHRA. ☪ Phone Wav. 451

*If you know a better den—go to it.*



## Wireless Weekly

12-16 REGENT STREET, SYDNEY, AUSTRALIA.

Phones: Redfern 964 and 930.

Official Organ of the New South Wales Division of the Wireless Institute of Australia, with which are incorporated the Affiliated Radio Societies and the Australian Radio Relay League.

Editor: A. W. Watt.—The Editor will be glad to consider Technical and Topical Articles of interest to Australian Experimenters. All Manuscripts and Illustrations are sent at the author's risk, and although the greatest care will be taken to return unsuitable matter (if accompanied by stamps), the Editor cannot accept responsibility for its safe return.

"Wireless Weekly" is fully protected by copyright, and nothing that appears in it may be reprinted, wholly or in part, without special permission. The use of our articles or quotations from them for any purpose whatsoever is never authorized.

VOL. 5 No. 25

APRIL 17, 1925

### Editorial.

#### WHAT IS AN EXPERIMENTER?

THE Wireless Institute of Australia (South Australian Division) has presented a poser to Mr. Malone, the Chief Manager of Telegraphs and Wireless, by requesting him to define the definition of the word "experimenter."

The dictionary will not help Mr. Malone very much, because it sidesteps the issue by merely remarking that an experimenter is one who makes experiments. A request from a South Australian for a renewal of his experimental receiving license met with an official refusal, and it is upon these grounds that the Institute now seeks enlightenment.

We have on our files several letters from readers complaining that, although in their opinion they are experimenters, this view is not shared by the Chief Manager, and he has firmly but nicely declined to give them other than the status of broadcast listeners. Why there should be any particular glory attached to the title experimenter as contrasted with that of broadcast listener, it is rather difficult to understand, because the hundreds of cases where former experimenters consented without protest to revert to the rank of broadcast listener upon the birth of the present regulations shows quite clearly that from the point of view of most of them there is no difference. All summed up, one has just as much latitude as a broadcast listener as is enjoyed by the receiving experimenter; so, from a practical standpoint, it is logical to conclude that, aside from the difference of a mere few shillings in the license fee, the receiving experimenter should be quite prepared to renounce his claim to the title upon the expiry of his license. The average broadcasting licensee is just as keen an experimenter, and probably spends just as much money and time upon his hobby, as does the man in possession of an experimental license. It must be remembered that under the sealed set regulations, one had to have an experimental license

in order to carry out any constructive work, but with the universal introduction of open sets there was exactly the same field opened to everybody, irrespective of the class of license held. It would be quite idle to deny that many of the former experimenters were experimenters only by virtue of the fact that they were permitted to use unsealed receivers; it would also be handling the truth carelessly to deny that the present administration has shown consistently by its actions that it is anxious to give experimenters a fair deal. We have only to contrast the status of the experimenter here with that of his unfortunate brother in almost every other country in the world to realise that there is a lot to be thankful for in the broadminded policy carried out by the administrators of the wireless regulations.

In this matter of the cancellation of experimental licenses, however, just as in any other, there is a sentimental aspect which, in view of that very broadminded policy, should not be ignored. Quite a number of experimenters attach a very high value upon their status, and it is a fact that, while many of them have carried out work which, broadly speaking, could be correctly termed experimenting, they unfortunately find it extremely difficult to define or to classify their work and to express themselves clearly, so that when called upon for a reasoned explanation their case is superficially very weak. Simply a matter of "I know what I mean, but cannot explain it to you." There are many men whose technical knowledge is very extensive, but they could never impart it to others, because they find it fundamentally impossible to do so.

The system at present provides for the consideration of each case individually for a receiving experimental license, while the transmitting license applicant is required to pass an examination. Perhaps it would be as well if the two were divided into classes, a definite examination allotted for each, and a proper syllabus drawn up so that it could be available to anybody.

This would dispose of any uncertainty, and would make the experimental receiving license a thing of material as well as sentimental value. It would also wipe out the present clauses (b) and (c) of paragraph 106 of the Regulations, which are somewhat ambiguous. An experimenter may commence work upon some particular subject, devote perhaps a week to it, and then spend the rest of the year upon anything but the matter in which he originally professed himself interested. In any case the correct definition of the word "experimenter" as applied to wireless has been a matter of debate and argument almost since wireless itself was discovered, and it will be a distinct advantage to have this important question settled once and for all by the one person most competent to judge—Mr. Malone.

HEADQUARTERS  
Royal Society's House  
5 Elizabeth St.  
SYDNEY, N.S.W.

# Wireless Institute of Australia

N.S.W. Div. Inc.

Incorporating the Affiliated Societies and The Australian Radio Relay League



Phil. Renshaw, Hon. Sec.  
Box 3120 G.P.O. Sydney  
Phone B2235  
A.H. Perrett Publicity Officer

## The New Council and the Old.

By the time these notes are published the election of the new council will have taken place, and possibly at this time of the year a few notes on the duties of councillors may not be amiss.

It is to be hoped that members of the New South Wales Division of the Wireless Institute of Australia will have exercised great care in marking their ballot papers, as upon the result of the ballot the success or otherwise of the Institute during the next twelve months will largely depend. In the past the council has always been a most harmonious body, and it is quite expected that this state of affairs will continue in the future. Of course, there have been those who have been more active than others in the conduct of the business of the Institute. This is always the case in every organisation; it seems to be one of the rules of Nature that this should be so. However, the duties of councillor extend further than the mere attendance at council meetings. By the way, this most important phase of the councillors' duties could be borne in mind a little more carefully by the incoming council than has been the case in the past with some members of the old council.

Every councillor should regard it as his sacred duty to attend every meeting of the council. If it is impossible for him to attend regularly, it is only fair to members generally that he should resign his position and make way for someone who has more time to spare.

But it is not only in attendance at council meetings that the councillors' duties lie; active members who will take an interest in every phase of the Institute's doings are required, and, above all, it is necessary that councillors should be workers.

The purely administrative side of the Institute's activities takes up a great deal of the councillors' time, but the scientific and practical phase of matters must not be neglected.

While extending to the new council the heartiest best wishes for the coming year, it should be pointed

out to them that a very strenuous time lies ahead, and if they are not prepared to work, it would be far better in every way to acknowledge this fact at the start and make room for others who will do their share for the Institute.

## Radio Relay League.

All members of the Wireless Institute of Australia, New South Wales Division, and members of affiliated societies, who are eligible for membership in the Radio Relay League, are reminded that a mass meeting will be held at the Royal Society's Hall, 5 Elizabeth Street, Sydney, on Wednesday, April 22, 1925, at 7.45 p.m. At this meeting it is expected that the Radio Relay League sub-committee will present its report of a concrete scheme for the operation of the League, and the meeting should prove interesting from every point of view.

## New Zealand Tests.

The schedule of operations for the New Zealand tests will be published at an early date, and it is hoped that these tests will be most successful in every way, quite the most successful ever held. The organising committee is looking for the co-operation of all transmitters to push these tests to a successful conclusion.

## Exhibition.

Don't forget the Institute's Exhibition. It will be held at the Sydney Town Hall from the 6th to 11th July, 1925. This Exhibition will be the biggest and most highly organised one so far held in the Southern Hemisphere. It is anticipated that the "house full" sign will be frequently exhibited at the doors. If members have any suggestions with regard to this Exhibition, or willing to help, they should communicate with the hon. secretary, Box 3120, G.P.O., Sydney.

## Annual Dinner.

Tickets are now available from club secretaries and at headquarters for the annual dinner of the New South Wales Division of the Wireless Institute. This function will take place at Sargent's Cafe, Mar-



ket Street, on Thursday, April 30, 1925, at 7 p.m. All those who anticipate being present on this occasion should make sure of their tickets at an early date.

#### QRM.

Has anyone applied for a gum drop from 2CM? 2WL will shortly be stabbing the ether. We hope to hear of some good work from this station.

Standard transmissions from 2CX will continue every Tuesday night at 10 o'clock. Special transmissions will be given on Tuesday and Wednesday, April 28 and 29, for the forthcoming New Zealand tests.

They're off!! The clubs have started in the competition for the MacLurean Cup.

Transmitters are warned. The publicity officer will soon be listening in, and your misdeeds will be recorded in QRM.

A. H. PERRETT, Publicity Officer.

#### SOUTH AUSTRALIAN DIVISION.

**T**HE Monthly General Meeting of the South Australian Division of the Wireless Institute of Australia was held in the Physics Lecture Room, at the Adelaide University, on Wednesday, April 1st.

The resignation of Mr. Hawke, through pressure of business, was received with regret.

A letter was received from Messrs. Fred Koerner & Co., advising of a quantity of X-ray apparatus for sale, many parts of which might be of use to members.

A further letter was received from a country member who has great difficulty in obtaining a renewal of his experimental license in spite of the fact that he is quite prepared to sit for the qualifying examination. The matter was referred to a special committee which has the matter in hand.

Messrs. Newton MacLaren Ltd., wrote advising that booklets advertising Philips valves could be obtained on application.

It was decided to obtain from the Controller of Wireless what was his definition of a wireless experimenter, and also to request the radio inspector to supply the Institute with a complete list of experimental licenses issued in South Australia.

Mr. Caldwell explained the working of a Tungar battery charging rectifier, giving all the necessary details regarding the construction of the

transformer used and the connections of the apparatus.

Mr. Churchward gave details of the construction and connections of auto-transformers for use with Tungar rectifiers, and explained the construction and working of the F.F. type of magnetic rectifier, and also of a Philips rectifier.

Mr Earle spoke on the theory and construction of electrolytic rectifiers for charging both high and low tension batteries.

At the close of the meeting the speakers were accorded a vote of thanks for the interesting addresses.

## Round the Clubs

*The asterisk denotes clubs affiliated with the Wireless Institute of Australia (N.S.W. Division).*

#### WAVERLEY RADIO CLUB.\*

A very well-attended meeting of the Waverley Radio Club was held at the club room, "Almont," Macpherson Street, Waverley, on Tuesday, 31/3/25, it being the half-yearly election of officers.

The president (Mr. Alan Burrows), in commenting on the past six months' work, said that the club was in a very sound position, and had been put on the map, as well as on the air. Much good work had been done, and he hoped the next half-year would see even more good work.

The club's transmitter is now working very efficiently, and its call sign (2BV) has been heard QSA in all States except W.A.

It has also been reported from N.Z.

The election of officers was then proceeded with, and resulted in the following:—President, Mr. A. Burrows; vice-presidents, Mr. Eric Bowman and Mr. Gordon Thompson; secretary, Mr. W. Anderson; assistant secretary, Mr. W. Horrell; treasurer, Mr. Miller; assistant treasurer, Mr. Simpson; committee, Mr. Cottrell (2ZN) and Mr. Graham; publicity officer, Mr. W. A. Stewart.

The meeting then closed.

#### CROYDON RADIO CLUB.\*

The usual weekly meeting was held on Saturday, March 28th, at the club room, Rockleigh, Lang Street, Croydon. The beginners' Morse class commenced at 7 p.m. and the weekly meeting at 7.30 p.m., Mr. C. W. Slade presiding. The hon. secretary was instructed that a letter of appreciation be forwarded to Mr. Walker for his donation of a valve

to be awarded to the winner of a competition, the nature of which was left to the club to decide. A discussion followed to find a suitable type of competition which would give a fair chance to each member. Cross word puzzles were barred.

Numerous suggestions were put forward, but as none appeared to be particularly suitable the matter was shelved until the next meeting. Mr. Pickering, of lattice mast fame, then donated a lightning-arrester. Mr. Luckman (2JT) was presented with a certificate conveying the club's appreciation of his working 9ZT a little while ago. The certificate was drawn by one of our members, and was of a very striking and neat design. Mr. Luckman was also congratulated upon the installation of his new transmitter (a daughter, Eve circuit), who is at present radiating a full amp. The tuning must be very sharp, as so far no complaints have been received of heterodyning the broadcasting stations.

A good number of questions were answered to the satisfaction of all concerned. Mr. Cutts gave a lecture on transmitters and related several of his recent experiments. Mr. Cutts' lecture was full of information and was greatly appreciated. Our next meeting on April 4th will be held at Station 2GM, when Mr. Cutts will give a demonstration of the many experiments related in his lecture. At the invitation of the Wireless Institute the club attended in full force the Film Exhibition at the Institute Headquarters, and spent a most enjoyable evening. Intending members should communicate with the hon. secretary, G. Maxwell Cutts, 25 Malvern Avenue, Croydon.

#### THE LEICHHARDT AND DISTRICT RADIO SOCIETY.\*

On Tuesday, April 7th, members of the Leichhardt and District Radio Society held their 30th monthly business meeting at the club room, 176 Johnston Street, Annandale.

The attendance was very satisfactory, and several important matters were dealt with, including the election of two new members. Discussion took place regarding the MacLurean Cup competition which is shortly to commence, and it was unanimously decided that the society take part in the contest. Arrangements are also being made for the construction of a wavemeter by the society, and it is generally agreed that the possession of such a valuable instrument will be of great benefit to all. It is also the intention of the society to erect and operate a low-powered transmitter, and it is expected that work on its construction will be commenced at an early date.

Next Tuesday night the society's 127th general meeting will be held, and this will take the form of a social evening, convened for the purpose of entertaining Mr. A. W. Watt, of "Wireless Weekly," and Mr. W. Hamilton, better known as "Insulator."

On the following Tuesday evening the 128th general meeting will be held, when the seventh lecture of Syllabus No. 3 will be delivered. The subject chosen for the occasion is "Batteries," and should prove very interesting and instructive.

Inquiries regarding the activities of the society are always welcomed, and should be addressed to the hon. secretary, Mr. W. J. Zech, 145 Booth Street, Annandale.

#### STRATHFIELD RADIO CLUB.\*

The ordinary weekly meeting of this club was held at the club rooms, 44 Bayard Street, Mortlake, on Monday evening, 6th inst. The attendance was a record for the club, being augmented by a number of visiting experimenters and members of other clubs, present by invitation on account of the unusually interesting nature of the programme arranged.

By courtesy of Amalgamated Wireless Ltd., a very interesting cinema film entitled "Modern Broadcasting" was screened, the screening being in the capable hands of Mr. Burbury, of their organisation. This film dealt in a most comprehensive and interesting manner with the various aspects of broadcasting, showing its value to the commercial man, the man outback and his good wife and family, and its beneficial influence in every home fortunate enough to possess the means of listening in. The method of operation of the various component parts of apparatus was well treated, an elementary exposition of the working of a valve being particularly interesting.

Previous to screening this film, Mr. Geo. Apperley, of the engineering staff of Amalgamated Wireless Ltd., gave a lecture, illustrated by an excellent series of lantern slides, on "Commercial Direction Finding."

In his opening remarks Mr. Apperley expressed his appreciation of the splendid attendance present, and the pleasure it gave him as a professional engineer to come along and meet the experimenters and give them a little useful instruction, and he chose the subject of direction finding because it offered a wide and interesting field for experiment. He traced the evolution of direction finding from the earliest experiments of Hertz right up to the present day, giving particulars and theory of operation of the various systems, and showing how by employing this system a commercial receiving station in England at



the present time was receiving six messages from various parts of the world simultaneously, on high speed automatic receiving apparatus, on the one aerial system.

Although a highly technical subject, it was excellently treated, and proved highly instructive.

At the conclusion of the entertainment the president, Mr. Jacob, in a neat and humorous speech, expressed the pleasure it gave him on behalf of the club in congratulating Mr. Apperley and Mr. Burbury on the excellent entertainment provided, and a hearty vote of thanks to these gentlemen and to Amalgamated Wireless Ltd. for their kindness in providing the film and slides concluded the proceedings.

More applications for membership of the club are being received, and intending members are requested to come along at 7.30 p.m. on Monday, 20th inst., when they will be admitted and the necessary formalities disposed of before the usual interesting entertainment commences.

An interesting paper will be read on this occasion after disposal of questions and answers.

Inquiries regarding the club's activities addressed to the hon. secretary, 44 Bayard Street, Mortlake, will receive prompt attention.

#### WAVERLEY RADIO CLUB.\*

Waverley Radio Club held another successful meeting at the club rooms, "Almont," Macpherson Street, Waverley, on Tuesday last, 7-4-25.

It was well attended, and it was pleasing to note the number of new members present.

It was decided that the club would build a wave-meter to be accurately calibrated from a known standard which it is hoped will be of use to the members of the club who are building wavemeters of their own.

The syllabus of lectures, etc., for the next month has now been completed, and it includes a debate, a sale and exchange night, a lecture on the "Q" list and procedure, and talks on general subjects.

The club's transmitter (2BV) is now regularly on the air, and satisfactory reports of the phone and C.W. are still being received from localities all over Australia and New Zealand. The club now has quite a collection of cards and letters from stations we have worked or stations who have heard us.

Every Sunday night after 10 o'clock the club will broadcast a news bulletin of the club's doings in the past week, and it should be of interest to listeners-in, but more particularly to club members.

After a general discussion on many subjects, and more particularly radiation meters, the meeting closed.

# SURPRISE THE FAMILY

Take Home a **LOUD SPEAKER** from

**Harringtons Radio Dept.**

386 George-st., City

New Shipments Just Opened—

**STERLING PRIMAX**—The very Latest

**Amplifiers** of all Models . from **40/-**

Visit our Showrooms for Demonstration

**Harringtons** 

**Photo and Radio  
Warehouses**

386 GEORGE STREET, SYDNEY (between King Street and G.P.O.);  
also at Melbourne, Brisbane, Adelaide, Katoomba, Auckland (N.Z.), Wellington (N.Z.).



AR III

# A DISTORTIONLESS AMPLIFIER

By "INSULATOR."

**A** LOW frequency amplifier as a separate unit is a most useful adjunct to anyone. It is somewhat unfortunate that one stage of note magnification is barely sufficient to yield satisfactory loud speaker results—hence two stages are always advisable.

Still more unfortunate is the fact that two stages of transformer coupled audio frequency amplification tends in many cases to produce distortion. Two stages of resistance coupled amplification, on the other hand, hardly produces the necessary volume. As a compromise this week I built a unit comprising one stage of transformer coupled and one stage of resistance coupled amplification in the order named, and right pleased am I with it. It is the sweetest thing I have ever heard. Not a scrap of distortion is apparent. I finished it on Saturday night, and, happening to have beside me the crystal set I described last week, I hitched it on, and, oh! my, "it was awfu' guid." Really it was so satisfactory and clear that I called in a friend of mine who reckons that wireless is all right, but it is so full of distortion that he will never instal one. He heard this, and has now changed his mind. Later on in the evening "Dulgie" (the amplifier) was backed to the ST100, and even in a small room the terrific attendant volume was quite pleasant to listen to. In naming the unit "Dulgie" I am only following out an old habit of mine (that of naming my re-

ceivers). In my time I've had "The Hearse," "The Coffin," "The Drainpipe," etc. "Dulgie" fits this nicely, so on Sunday morning, in the presence of a half-dozen sets, two dozen valves, etc., I performed the solemn rite of christening by sprinkling it with a few healthy electrons—Glaxo brand.

An amplifying unit is a very mobile piece of apparatus. To almost any receiver can it be coupled for loud speaker results. This one in particular is quite a cheap piece of apparatus, even when the best stuff is used. Instead of, say, 30/- for a good transformer for a second stage, two resistances costing 1/6 each plug, one .006 condenser at 3/9, serves the purpose, and well, too. Here's the materials I used:

- 1 Piece of mahogonite, 10 x 5 x 3/16 in.
- 2 Rheostats with dials.
- 10 Ebonite topped terminals.
- 1 Single circuit jack.
- 1 Jefferson transformer.
- 2 Standard American valve sockets.
- 2 .001 Fixed condensers.
- 2 .006 Fixed Condensers.
- 4 Grid leak elips.
- 1 100,000 ohm Resistance.
- 1 2-Megohm leak.
- 12ft. Square bus bar.
- 1 Bakelite strip, 7½ x 1½ x 3/16 in.
- 1 Baseboard, 10 x 6 x ½ in.
- Sundry screws, etc.

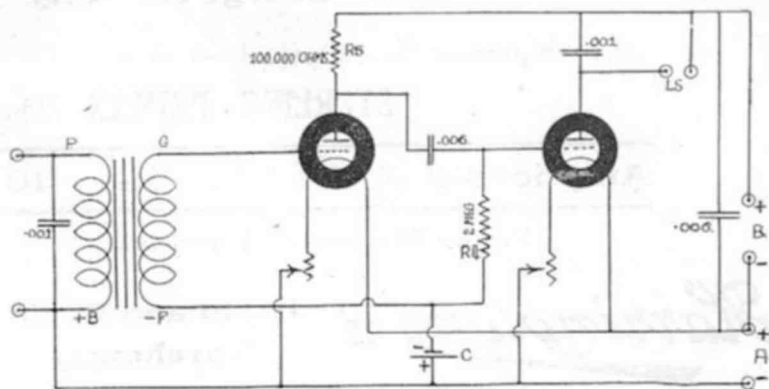

The Circuit.

WATCH FOR THE SOUTHERN CROSS.

The panel layout is simplicity itself. As can be seen in the illustration, there are four terminals, one jack, and two rheostats mounted thereon, the rest of the equipment being placed on the baseboard. Actually the rheostats are both placed on a line midway between the top and bottom of the panel, and each is  $2\frac{1}{2}$  inches from its nearest end. The bottom terminal in each instance is  $1\frac{1}{2}$  in. from the bottom, and each are  $1\frac{1}{2}$  in. apart. The centre of the jack is  $\frac{1}{2}$  in. from the bottom and  $1\frac{1}{2}$  in. from the edge. Provision is made for three small holes for screwing the panel to the baseboard.

While the drill is in your hand, drill six holes, each  $1\frac{1}{2}$  in. apart, on the strip of bakelite. These are for the battery terminals. Put your drill on the one side now, and take a long look at the back view in the illustration. Note the transformer on the right side—the two valve sockets and the fixed condensers sticking up in the air like silos. The jack shows up plainly. In between the two sockets can you see the

2 megohm grid leak (R4)? From the plate of the right-hand valve socket to the grid of the next socket is a .006 fixed condenser maintained erect by two pieces of bus bar. Immediately in front of this will be located the 100,000 ohm resistance (R3). Still, I am running away from myself.

The baseboard of the dimensions given should be well shellaced. Next screw to it the transformer and the two sockets, these latter about  $1\frac{1}{2}$  in. apart and about  $1\frac{1}{2}$  in. from the panel edge. Between the sockets screw down two clips for R4. About  $1\frac{1}{2}$  in. behind this screw down two more clips at right angles to the already placed clips. Leave your screwdriver down and pick up your round nosed pliers. The pointer terminal of the two rheostats may be wired together, the lead continuing to the terminal P. From P to G a .001 fixed condenser (C2) is shunted. Now screw your panel to the baseboard and proceed with the wiring. Don't be in too big a hurry; take

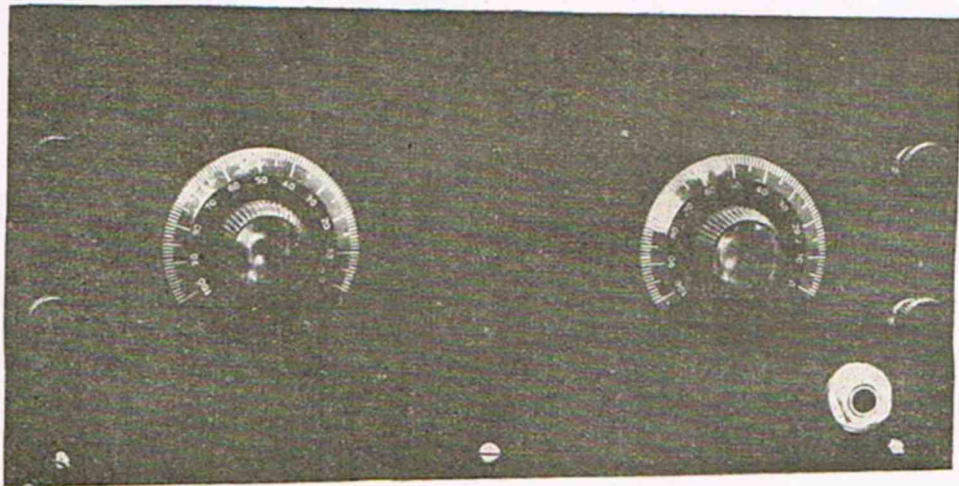

*Front Panel View.*



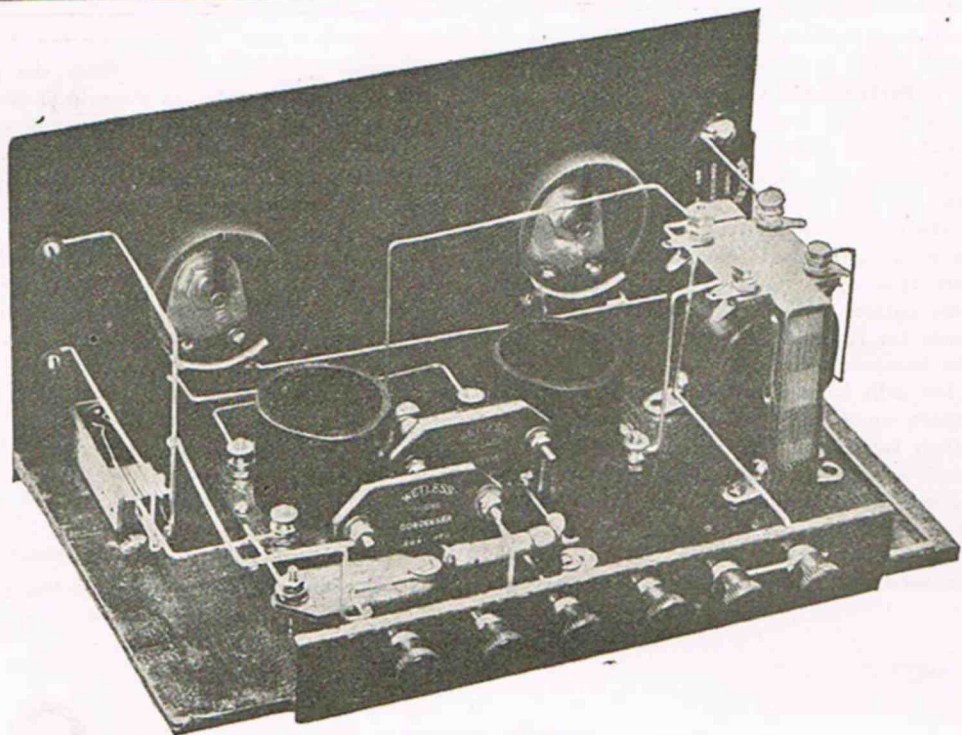

*Back View of Panel.*

it easy bit by bit. Wire the remaining rheostat terminals to the minus filament terminal of their respective valve sockets, and wire from the panel to the battery terminal board. The illustration will show you the positions of the various pieces of bus bar. No difficulty should be experienced in reconciling the circuit with the back of panel views. The terminal board at the back has the battery terminals. Reading from left to right they are: B positive, B negative, A positive, A negative, C positive, and C negative. In order to obtain the loudest signals it is advisable to employ a B battery of the order of 100 or 120 volts. The C battery consists of two ordinary No. 1000 torch refills, thereby biasing to the extent of 9 volts. It sometimes happens that this biasing battery is not essential. Then one only needs to connect a short length of bus bar across the C battery terminals. This process is known as shorting the terminals.

The appearance of this receiver would be greatly enhanced by enclosing it in a nicely polished cabinet. Personally, I can't assist you in this, because as a carpenter I am the limit. Everything connected with the timber trade (even chopping) I leave to Mrs. Insulator, who, unfortunately, was too busy this week. So pleased am I with the quality of reception from this unit that I propose building a unidyne circuit (Continental type) to work in harness with it.

Then I can assure myself of sweet, pure reproduction.

#### A SIMPLE LEAD-IN.

Some amateurs are not able to bore holes in window frames for their leads-in, and it is often a problem for them to know how to get an efficient connecton between the aerial and the set. A simple and satisfactory method of providing a lead-in is to take a strip of brass or copper-foil and cover it with insulating tape, leaving about 1 in. at each end uncovered. To each end can then be attached a terminal, preferably of the phone type. This lead-in can be placed on a window-sill and the frame closed without hurting it in any way. Only thin foil should be used or it will not conform with the contours of the sill.

#### SPECIAL.

On Sunday, April 19th, from 10 a.m. to 11 a.m. Sydney time, watch for WGY on 100 metres, as at that time he is broadcasting a special French programme.

SACRIFICE.—One Valve Set, without coils, valves, batteries, 50/-; or with, £5/10/-. New. Apply A.W., c/o "Wireless Weekly."

WATCH FOR THE SOUTHERN CROSS.

# MULTI CIRCUIT RECEIVER

Employing H.C. or Basket Coils

By J. S. TAYLOR.

**T**HE receiver, the circuits of which will be detailed in this article, is one which gives a choice of five good circuits. By building the receiver with as little "losses" as possible, very good results will be obtained on short waves. It is impossible, of course, to obtain as good results on short waves as on long waves using the one receiver, but by using good components, low loss condenser, porcelain socket, good low loss valve, and low loss coils, the receiver will prove very good on all waves.

The following is a key to components required, and also to circuit diagrams. A1 and A2 aerial terminals, E1 and E2 earth terminals, SPS series parallel switch, S1 and S2 small battery switches, C1 .0005 mfd. variable condenser with vernier (C1 may be .001, but on lower waves .0005 will prove better), C2 and C3 .001 fixed phone condensers, mica dielectric, CD crystal detector unit, V valve and socket, R rheostat (6 ohm for accumulator fed valves, 35 ohm for dry cell valves), GC grid condenser, mica dielectric, L grid leak, Ps1 crystal circuit phone terminals, Ps2 all valve circuit phone terminals, L1, L2, L3 represent three coil holder, two being variable, L1 and L3. Battery terminals are represented in diagram in the usual manner.

## To Use the Receiver as a Loose Coupled Crystal Detector.

Earth to E2; aerial to A2. Primary coil to L2; secondary to L3. C1 in parallel for higher waves and in series for lower waves. Phones on Ps1; S1 and S2 "open" in off position; batteries switched

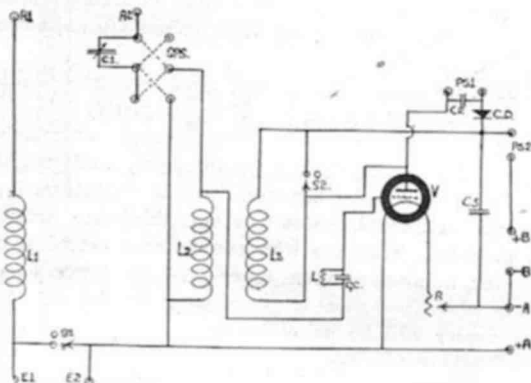

off. Juggle the catswhisker, and—there you are! Until the correct setting for condenser C1 and the coupling of coils are known for each station when the crystal is in use, it would be better to tune in on the P1 valve circuit first, switching over then to the crystal circuit.

## Using the P1 Detector Circuit.

Same as for the crystal circuit, but with phones on Ps2 and batteries on, of course. In all valve circuits see that the catswhisker is off the crystal.

## Using the Single Coil Non Regenerative Circuit.

The same as for the P1, but withdraw the reaction coil from L3, and close S2, so shorting the reaction coil holder, and continuing the plate circuit.

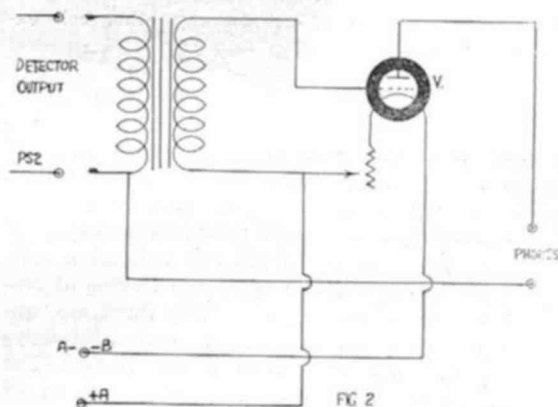

## Using a 3 Coil Circuit, Tuned Secondary.

Loose coupling between L1 and L2, and primary, secondary and tickler coils plugged in to L1, L2 and L3 respectively. Earth on E1, C1 in parallel, S1 and S2 open, aerial to A1. This circuit is very selective, and I would advise tuning in first on the P1, changing the aerial and earth over after the station has been received, and then varying the coupling until the station again comes in. It may be better to use coils of the same size in L2 and L3 in this circuit, also for the next. Using this circuit for reception of 2BL, I use coils as follows: L1—30 or 35, L2 and L3—45 to 50. (Basket coils.)

## Another 3 Coil Circuit.

Same as for the last circuit, but "close" S1. This circuit is about the best on short waves, and if

the receiver has been built on "low loss" principles as far as possible, amateurs may be picked up by the dozen. I do not claim that the receiver will bring in KDKA. Oh, no! But by adding a stage of audio, you'll get long and short wavers both, over good distances. A stage of audio can be added to this receiver if desired by connecting the "input" of the audio unit to the phone terminals of the detector unit, and the same batteries may be used. Circuit diagram No. 2 shows how this may be done. I strongly recommend basket coils and wound with heavy gauge wire for short waves; use D.C.C. wire, and use no dope whatever. Cut away as much cardboard as you possibly can, such as what remains of the lugs when the wire is on, and most of the centre. Coils for 2FC and up to 2000 metres can be wound on basket formers or spider formers by using 28 enamelled wire, and by taking the wire under and over two lugs at a time instead of under and over one lug. I have 200 winds of 28 enamel on one former so wound. Basket coils are cheap and easy to make, and can be so easily altered if not correct. By using them on short waves you will bring in amateurs you will never get on any other coil except the "low loss" type.

#### THE STRUGGLE AGAINST MONOPOLY.

After obtaining views of its members, the French Society of Wireless Studies (Societe francaise d'etudes de T.S.F.), the oldest wireless association in France, representing more than 42 regional groups and over 5,000 amateurs, has adopted and sent to the Prime Minister a resolution calling on the Government to apply the Decree of November 24, 1923, which, while leaving the State "absolute master," sanctioned the installation of duly-authorized private local broadcasting stations. The Society condemns the present proposed form of monopoly — and incidentally, all other forms, too — and disapproves of paying the expenses of wireless transmission by means of taxes on receivers. It holds such a measure unjust, as it would place "humble crystal" on the same fiscal level as elaborate valve sets, which, functioning in many cases with indoor aeriels, would "easily escape control."

The Society also holds that wireless revenue raised should be collected in the form of duties on valves and components, and transmission stations should not be prevented, as at present, from broadcasting paid publicity. The receipts realised under the proposed regime should, in the Society's opinion, be distributed by an autonomous association — representing manufacturers, broadcasting firms, etc.—amongst the owners of transmission stations in proportion to their general expenses, after deduction of a percentage for authors' rights.

#### COLORING SOLDERED JOINTS.

There are usually not many soldered joints which are visible to the eye in well-constructed wireless sets, but occasionally it is necessary to make such joints in places where they are visible. Especially is this the case in purely experimental sets.

If the wires which are soldered together are composed of copper, the joint may be given the same colour as the copper itself by a very simple process.

First of all prepare a saturated solution of copper sulphate by dissolving in an ounce or two of hot water as much of the blue crystalline salt as the liquid will take up. Paint this solution on to the soldered joint, and touch the joint with an iron or steel wire which has been made slightly warm; a layer of metallic copper will be deposited on the solder of the joint. The process can then be repeated until the metal around the joint attains the same colour and shade as the rest of the wire.

For experimental workers, and for those who exhibit their apparatus at club meetings or in public, the process is certainly worth trying. It needs a little practice, but, given that, many an unsightly joint can be neatly covered up with a permanent layer of metallic copper.

#### CORRESPONDENCE

To the Editor.

Dear Sir,—I understand that the way to improve the broadcasting programmes is to distribute applause or hisses to the broadcasting companies through the medium of the Press.

May I beg for more broadcasting of real entertainments that are actually being held in Sydney? What we want in the country is to be able to listen to the programmes that our city friends write and tell us about—not to waste time on artists whose reputation is so limited that their names are unknown to all country dwellers.

Give us more theatres and good concerts—Gallie-Curei and all the rest of it. The fees justify it!

Parliamentary debates have proved extremely popular with the older experimenters, and might well be broadcasted whenever there is an interesting discussion expected. Cut out the third-rate artists and give us performers who can draw a crowd that pays for admission, then there will be fewer complaints about the 35/- a year, and the lot of the radio dealer will be an easier one.

Yours, etc.,

COUNTRY DEALER.



## Converting a Three Valve Broadcast Receiver to a Short Wave Receiver

SO many of our readers have written us requesting a back view of the wiring of this circuit that we have been forced to find room for it in this week's issue. We trust that those readers will accept this article as an acknowledgment of their letters, and hope they will be as successful with their converted receiver as we have with the experiments carried out.

It is possible with this hook-up to transfer from Broadcasters' or Farmer's to receiving amateurs as low as 50 metres. With our own set a loud speaker is used the whole time, whether on New Zealand or American amateurs.

The method of winding and mounting the short wave coils necessary for this receiver will be found on page 10 of "Wireless Weekly" dated February 27th, 1925. It will be readily seen that with the aerial connected to the top aerial terminal and the home-made coils in position, the set will function on short wavelengths from 50 200 metres. Care should be taken that the variable tuning condenser is in

parallel. Probably some of our readers who are at present using the P1 circuit have their condensers in series. If so, it will have to be altered if the quick change from short to broadcast waves is desired.

With the aerial connected to the lower aerial terminal, the ordinary P1 circuit is in use with the variable condenser in parallel across the primary coil, and by simply plugging in your honeycomb coils in lieu of your home-made ones, the set will operate on wavelengths as high as your honeycomb coils will allow you to tune to. It must, however, be remembered that those who have been using a series condenser are now forced to use the condenser in parallel, so that smaller coils must be used in the primary circuit if the aerial is taken to the lower terminal.

If, however, the aerial is left on the top terminal for the broadcast wavelengths, as is the case with the short waves, then, of course, the larger coil will be satisfactory. Readers who suffer from interfer-

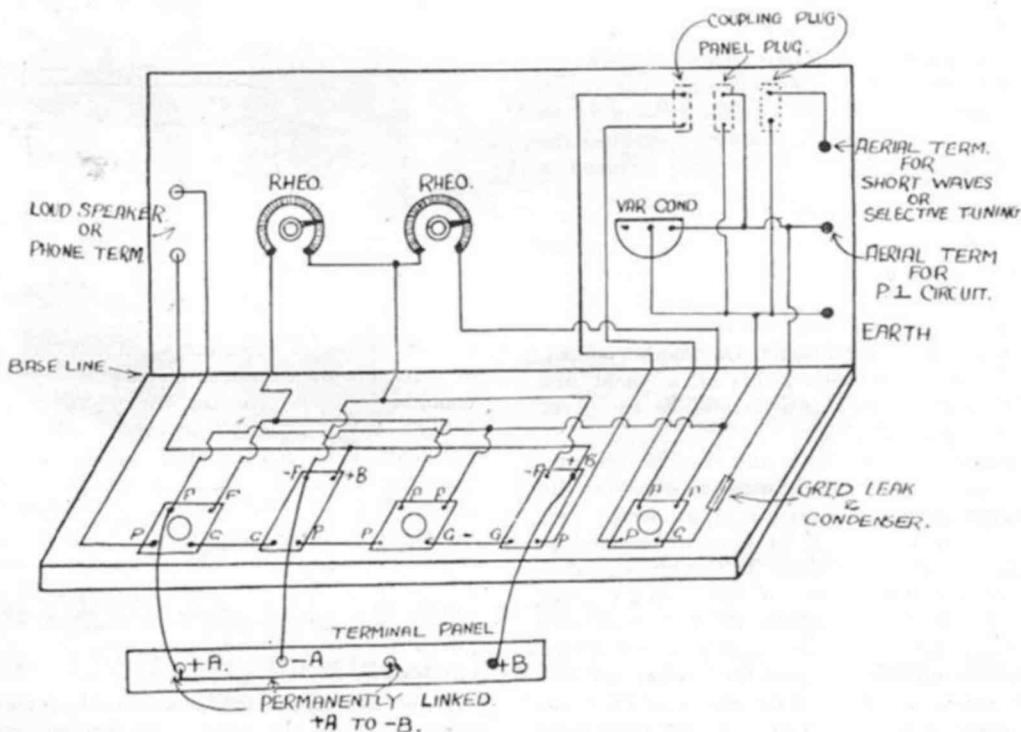

ence from Pennant Hills whilst listening to broadcasting will find their receiver much more selective by using the aperiodic aerial tuning system (viz., aerial on the top aerial terminal). Here is the table of coils used in "Wireless Weekly's" set. Note the different sized coils for aperiodic primary and the P1 circuit:—

#### SELECTIVE TUNING (3 COIL CIRCUIT).

(Aerial on top terminal; aerial aperiodic.)

Station. Primary. Secondary. Reaction or Ticker.  
Amateurs.

50-200 metres. 5 10 15

2BL 10 50 75

2FC 50 or 75 150 200

#### NON-SELECTIVE P1 CIRCUIT.

(Aerial on Bottom Terminal.)

Station. Primary. Reaction.

2BL 25 or 35 75

2FC 100 or 150 200

### OH, THOSE MOVIES.

Have you ever noticed the weird and wonderful wireless effects frequently worked into otherwise irreproachable films? One night recently, we observed with mixed feelings the film version of how we wireless. 'Twas a scene on board a millionaire's yacht and seated at the wireless table was a young and handsome youth who listened with a strained look to what was apparently an S.O.S. Nothing so fearful, however, for after a moment, he wrote down a message addressed to the hero informing him his uncle was seriously ill. The villain who was standing near—they always seem to be just in time to intercept the message—grabbed the radiogram and with a sardonic grin, penned a reply. It was simply addressed to the uncle, without any address. The youthful operator immediately started sending the message without any preliminary call and on the same instrument with which he received the message. It was apparently a three valve receiver with no external signs of being connected to anything. On another occasion we thrilled to a radio scene on a yacht and later on we were treated to a close up of the yacht without an aerial showing.

On Sunday, March 29th and in full daylight, Mr. P. Boulton, of Albury, worked KGO on the loud speaker for three quarters of an hour. Mr. Boulton is now logging KGO four times weekly, and excepting occasions when he is absent is able to tune in KGO on each of their broadcasting nights. Another American station who announces when closing that "it is now 12 o'clock" has twice been received during the past few days, but the call sign which is not familiar and was only announced once on each occasion, was not picked up.

## "Reinartz" All Wave Receiver

### Adapted for the Broadcast Bands

By G.W.S.

HAVING carefully built your "Reinartz" receiver for the reception of "short" waves and eliminated all avoidable "inductivity" and "capacity," you desire to receive programmes broadcasted on waves from 320 metres to 2000 metres, you will find that some modifications are necessary.

Coils wound for reception of waves up to say 320 metres can be conveniently wound with heavy wire and liberal spacing of turns but over this wave length they become bulky and unwieldy. To build them of a convenient size for the longer waves, smaller wire and closer spacing may be used.

To the mind of the experimenter the reasons underlying the necessity for "low capacity" coils and apparatus for the reception of "short waves" and the necessity for increased capacity for the reception of "long waves" are at once introduced.

I purposely avoid the term "low loss," as, although it is a convenient name for every day

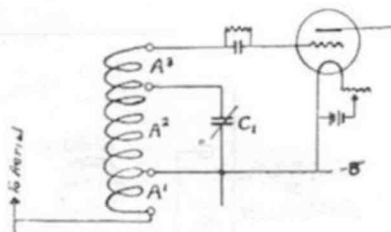

FIG. 1

use, it is not a scientific term and for purposes of scientific or technical discussion is not definite enough. There are the two quantities "inductivity" and "capacity" involved, and each must be dealt with individually. Both are variable quantities and both have a varying relationship to wavelength. We know that "inductivity" or the value of an inductance varies as the square of the turns of the coil. This is true within certain limits depending on the shape and size of the coil. The mathematical side leading up to this point may be obtained in any treatise on Electricity and Magnetism.

We also know that wavelength varies as the square root of the product of the inductivity and

capacity of the coil. Therefore it follows that wavelength varies as the produce of turns (T) and square root of the capacity (C).

Put mathematically:—

- I. L (Inductively) varies as  $T^2$   
 II. W (Wave length) " "  $\sqrt{L \times C}$   
 III. W " " " "  $T \times \sqrt{C}$

If W is small it follows that T and C must be small also, therefore we use a small length of wire and wind it in such a way that its capacity (mutual and dielectric) is also small.

If W is large, T and C will be large also; and as for convenience T cannot be too bulky or unwieldy, C can be increased.

This explains briefly why "low capacity" apparatus is necessary for the reception of short waves.

A coil wound on the 1:3:1 formula, around 9 pegs on a 2½ in. diameter circle with 20 DCC wire, and 11-33-11 turns having a .0005 MF capacity condenser in parallel with the centre portion was found to have approximately the same wave length as a coil of the same size wire wound around every second of 18 pegs on a 3½ in. diameter circle with 14-42-14 turns and a .00025 MF condenser in parallel with the centre portion.

There was exactly twice the length of wire used on the larger diameter coil, therefore, its capacity was very much less than that of the smaller coil. This serves to illustrate that in order to increase the wave length without using a great quantity of wire we must introduce capacity into the circuit. †

The last section A3 of the coil for a "Reinartz" receiver (Fig. 1) may very well be dispensed with and the coils wound simply 1:3:0 with the terminals for the portion A3 short circuited.

Broadcasters (2BL) on 350 metres came in very well with 14:42 turns of 20 S.W.G wound on spider web formers and placed side by side and for Farmers (2FC) on 1100 metres two honeycomb coils 50:150 gave very selective tuning. For convenience these coils can be mounted on a two plug coil holder and connected to the terminals of the set used for the "shortwave" coils by lengths of flexible wire.

Now comes the "nigger in the wood pile." You must increase the capacity to balance the inductivity of the coils above mentioned in order to tune in these long waves sharply. The two carefully selected 11 plate low loss (so called) condensers that you have built into your set will not do. A .001 capacity variable must be used for C1 and a .0005 capacity may be used for C2. It

is not necessary to remove the smaller condensers from the set, you can simply connect the two larger condensers in parallel with their terminals preferably disconnecting one lead of the 11 plate originally used while receiving the longer waves.

(The reader should look up articles on "Reinartz" All Wave Tuner published in Wireless Weekly of September 5th, 1924 and subsequent issues for the above references).

#### CAPETOWN HEARD AT WYONG.

Mr. O. G. Chapman, the Wyong agent for the Western Electric Company (Australia) Ltd., reports having received broadcasting from the station at Capetown, South Africa. This is the first recorded occasion on which South African broadcasting has been reproduced in Australia.

Mr. Chapman's is a standard A131 Western Electric 5-valve set. He listened in to ukulele and piano-forte items, "Someone is Calling," "At 3 o'clock in the Morning," "Come and Dance With Me," to a humorous sketch, "Begun," and to two songs, "I Love You" and "I'm Ticked to Death I'm Single." These were reproduced quite distinctly.

Mr. Chapman, it is interesting also to note, first picked up the Los Angeles broadcasting station.

Headphones operate the best when the positive side of the phones is connected to the positive lead of the B battery. Some phone cords are marked with a red stripe to indicate the positive cord of the phones. But if the phones are not marked, try them connected one way and then reverse these conditions. The positive side will be indicated by the connection that give the clearest and loudest signal.

Users of reflex circuits who live in districts where there are A.C. mains, must not be surprised if they do not get very good results. Some of the latest circuits are so sensitive that one can only hear the A.C. hum. Whilst the interference is bad with phones, it is frequently possible to get good results with a loud-speaker, as in this case the hum is not heard to any appreciable extent.

Telephone B 5925

**CHARLES D. MACLURCAN**  
 Consulting Radio Engineer

Pratten Building,  
 26 Jamieson Street,  
 SYDNEY



## PREPARING FOR *The Amateur Operator's Proficiency Certificate*

(Continued.)

By "WIRELESS WEEKLY."

**L**AST week's article dealt with the electronic theory, good conductors and bad insulators, bad conductors and good insulators, and definitions of various electrical terms.

Those of our readers who intend sitting for the Government examination will be wise to cut these articles out of "Wireless Weekly," so that they can have a final run through the whole course a few days prior to their examination.

### Electric Current.

An electric current is nothing more nor less than electricity in motion. There are three well known types of electricity movement—one, conduction currents; two, displacement currents; and three, convection currents.

(1) A conduction current is the electric current which flows in a conductor which forms a closed circuit. As long as the E.M.F. is impressed on the circuit, the conduction current will flow.

(2) Displacement current is the current which flows momentarily in a dielectric or insulating material when an E.M.F. is impressed across that material, or when an E.M.F. impressed on that material is changed, either by increasing or decreasing intensity. When an E.M.F. is impressed across a piece of insulating substance, a charging or capacity current flows momentarily in the direction of the E.M.F. This is because the electrons in the atoms are being strained in one direction and the atoms allow a certain movement of the electrons, but do not permit them to move from one atom to another. (See last week's article.) This electron movement ceases as soon as the E.M.F. reaches a steady value, but by increasing or decreasing the electrons are either strained a little further or allowed to return a little to their normal position. Thus it will be readily understood that a displacement current only flows when the applied E.M.F. is increasing or decreasing. If the applied E.M.F. does not vary in intensity across the insulator, dielectric will remain in a state of strain.

### (3) Convection Currents.

These are currents which are due to the movement of electrons or positive and negative ions. Example 1, through the acid of a cell; 2, between the

filament and plate of a valve. These currents, however, will be dealt with more fully later on. Just as the yard is the British standard of length, so in electricity it is necessary to have certain well-defined units on which all calculations may be based. These units and definitions were discussed last week, so that we should now be well prepared to go right ahead with the electrical measurements as required from a radio point of view. We will, however, first deal with electro motive force, known as E.M.F. The term electro motive force, sometimes called voltage, electric pressure, or difference of potential (D.P.), is used to designate the "push" that moves or tends to move electrons from one place to another—that causes electricity to flow. The flow of water through a pipe—that is, the number of gallons per second—is determined largely by the hydraulic pressure in pounds—that is, forcing the water through the pipe. A similar electric pressure or E.M.F. measured in volts causes the electricity to flow. A volt has, when speaking of electricity, somewhat the same meaning as has a force of one pound, when speaking of hydraulics. A greater pressure is required to force a given amount of water through a small pipe than through a larger one in a given time.

Similarly, a higher voltage is required to force a given amount of electricity through a small conductor than through a large one in a given time. Read the above carefully, and then you will see for yourselves why "Ohms law" is based absolutely on

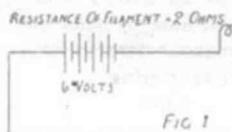

$$C = \frac{E}{R} = \frac{6}{2} = 3 \text{ AMPERES}$$

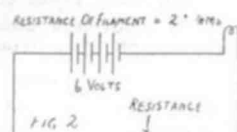

$$C = \frac{E}{R} = \frac{6}{6} = 1 \text{ AMPERE}$$

facts where continuous currents are concerned. E.M.F. is generated in three different ways:

(1) By two dissimilar metals or other substances being immersed in certain liquids, such as acids of primary and secondary cells.

(2) By two dissimilar metals being placed in contact, and their junction heated, i.e., thermal junc-

tion of steel and eureka wire used in wavemeters.

(3) By a conductor being cut in a certain manner by lines of force, i.e., dynamo, transformers, etc.

The practical unit of electrical pressure is the volt, and it is the electro motive force required to drive a current of one ampere through a resistance of one ohm.

#### Ohm's Law

States: The strength or rate of the flow of an electric current varies directly as the difference of electrical pressure or electro motive force, and inversely as the resistance. Expressing these values in units, as mentioned in last week's article,

$$\text{Current in amperes} = \frac{\text{Electro motive force in volts.}}{\text{Resistance in ohms.}}$$

$$\text{or } C = \frac{E}{R}$$

or, electro motive force in volts = current in amperes multiplied by resistance in ohms,

$$\text{or } E = C \times R$$

$$\text{or, Resistance in ohms} = \frac{\text{Electro motive force in volts.}}{\text{Current in amperes.}}$$

$$\text{or } R = \frac{E}{C}$$

The above formulae are only applicable with direct or continuous currents, but it is essential to have a clear understanding of the above before going further. With alternating currents other considerations come in, and Ohm's Law requires considerable modification.

Fig. 1 gives an example: A battery of 6 volts is connected to the filament of a valve whose resistance is 2 ohms. Find the strength of the current.

Fig. 2 shows the same valve used in conjunction with a 4 ohm resistance.

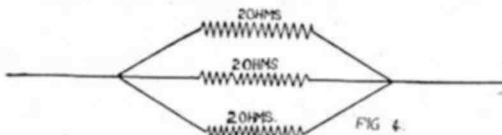

It will be readily seen from the above two figures that if a variable resistance or rheostat be used in lieu of the fixed resistance, the strength of current can be changed at will—in this case, up to a maximum of 3 amperes and minimum of 1 amp. It must

be remembered that if the E.M.F. and resistance remain constant, the current will remain constant. Where batteries are used, as in A battery for filaments of receiving valves, the battery runs down with use; therefore the resistance must be reduced as it does so, to supply the valve with sufficient current to operate the filament at the right degree of heat the whole time.

#### Resistances in Series and Parallel.

If resistances are placed in series as in Fig. 3, there will be a voltage drop in each resistance, and the current flowing will be cut down accordingly, as is the case with the rheostat and filament in Fig. 2.

Fig. 4 shows the same resistances in parallel. Note the drop in total resistance. Here the total resistance is smaller, because the current has several paths in which to flow. Compare it again, if you like, with the water flow having several branch pipes attached to one main flow.

Formula for resistance in parallel—

$$\begin{aligned} &= \frac{1}{R} = \frac{1}{2} + \frac{1}{2} + \frac{1}{2} \\ &= \frac{1 + 1 + 1}{2} = \frac{3}{2} \\ \therefore R &= \frac{2}{3} = .6 \text{ ohms.} \end{aligned}$$

The effect of arranging resistances in parallel is to reduce the total resistance. The total resistance will be less than that of the smallest of them. The opening up of more paths for the current will make its passage easier, just as opening up a number of gates in a ground containing a crowd of people will make their exit easier.

The unit of electrical power is the watt, and is calculated by the following formulae:—

$$\text{Watts} = \text{volts} \times \text{amps.}$$

Example: The voltmeter of a valve transmitting set reads 600 volts. The plate milliamp meter reads 50 milliamps (or one-twentieth of an amp.).

$$\text{Watts} = \text{volts} \times \text{amps.}$$

$$600 \times 50$$

$$\text{Watts} = \frac{\quad}{1000} = 30 \text{ watts.}$$

In this case we divide by one thousand, as one thousand milliamps equal one amp.

Example No. 2: If a 240 volt, 32 candle-power metal filament lamp takes 1.7 watts per C.P. from the 240 mains, find what current it consumes.

$$\text{Watts} = 32 \times 1.7 = 54.4$$

Note the change of equation from watts = voltage x current.

$$\text{To Current} = \frac{\text{Watts}}{\text{Voltage}}$$

$$C = \frac{54.4}{240} = .221 \text{ amp. (approximately).}$$

A few questions based on the above article:

- (1) Explain what you know about conduction currents and displacement currents.
- (2) What is meant by the term E.M.F.?

(3) Define Ohm's Law and explain it.

(4) A 6 volt battery is joined direct to the filament of a valve whose resistance equals 6 ohms. What current will flow through the filament?

(5) What is the total resistance of the following:—Resistance placed in parallel, 4, 6, and 8 ohms?

(6) A transmitting valve takes 300 volts on the plate. Plate current equals 20 milliamps. What is the input in watts?

## INTERSTATE NOTES

### VICTORIA.

#### "Gems from the Classics."

Three gems from the classics as served up by our weekly contemporaries are: "VOLTAGE—The electro motive force of a source of electric supply sent through a circuit of a certain resistance."

This sort of definition ought to be set as an examination paper, complete in itself, for candidates to pick out all that is wrong in it. Can you? One or two errors only need be touched on here. First of all, there was no need to drag in the "source of electric supply." Next, there can be a voltage without a circuit. Thirdly, resistance is simply not in it, let alone a "certain" resistance. This sort of definition merely clouds the issue it professes to explain.

"Many telephone receivers have been taken from public telephone cabinets, but in this case the thieves gained nothing, as this type of low resistance receiver is useless for wireless work."

In this case the thieves evidently knew more about wireless than the presumably honest ignoramus who wrote the paragraph. He must be in the P.M.G.'s Department!

"If covered wire is used for the aerial, atmospheres are almost negligible."

Here, indeed, is good news, although unreliable, for the lover of music who listens-in to 3LO's new jazz orchestra! Covered wire for his aerial will supplant cotton-wool for his ears!

#### Low Loss Coils.

Everybody has something to say about low loss coils nowadays, so just a word to those few who merely listen. When the next expert tells you his latest conclusions, find out on what he bases them. If on theory, does he know his theory? If on practice, has he tried it thoroughly in every way? A lot of loose talk is going the rounds (it is mainly misquotations and misapprehensions from the American journals) advocating thick wire as being of low

resistance and, therefore, ostensibly of low losses. The amount of wire used in short-wave coils is relatively so short that this factor does not count for much. Separating the turns in a coil lowers the inductance much less rapidly than it lowers self capacity, but adds a great deal to the total length per unit inductance, and therefore greatly increases the total resistance for the same gauge of wire used. Much of the success of a low loss set is due more to the excessive care bestowed on its layout, the simplicity of its circuit, and the soldering of its joints, than to the mere details of its coils. The best test of a set is not whether it will bring in long distance stations never heard before, but whether it will bring in loudly the old familiar station so far heard but faintly.

#### The "Radio" Voice.

Exactly what a "Radio" voice is we have not yet been told by the experts, although a competition to discover what the public thinks are the best ones has just been concluded. Dr. Loftus Hill recently assured us that there is a special "radio quality" about some voices, but he does not give chapter and verse for this statement, the elucidation of which should be extremely fascinating to a man of science. In this connection the writer deliberately paid the full sum of one shilling to be admitted to the Assembly Hall during the currency of the competition in order to hear the special megaphones installed there. There were present exactly four other persons, and the megaphones blared down upon us from the organ-loft like loud uplifted angel trumpets with a remarkably American accent. The unfortunate soprano was transmogrified into a muffled semi-contralto, and her exquisite high notes, the loveliest window-dressing of her dainty stock-in-trade, became mere shriek and blare as of a megaphone in its death-agony. Brief notes were made of the announcer's diction. He presumably spoke with a Scotch or North of England accent, but the faithless mega-

phones endowed him with a voice that one would attribute to Mr. Nosey Parker, of New York. The vowel sound in words like "fall" and "four" were greatly resented by the megaphone. The sound of "s" afflicted it as if it were a rattlesnake. The letter "n" insisted on assuring us that even megaphones can have a cold in the nose. If the success or failure of future vocalists is to be judged through instruments such as these, then, indeed, Australia will be overrun with the lineal nephews and nieces of dear old Uncle Sam, without any further visits from his official Fleet being at all necessary! Any listener-in who takes the trouble to compare the same voice in the same song in two consecutive verses, one through a telephone and the other through a loud speaker as usually installed, will not fail to observe that opinions as to the voice would vary according, not to the vocalist, but according to the instrument through which the voice emerged. When even a loud speaker is properly adjusted by an operator with at least two musical ears, of course the effect is altogether different, but the present practice of the trade is to allow young men of enthusiasm to handle these delicate instruments as if they were bugles competing with a full brass band, and too evidently most of these young men cannot distinguish between Liebel's "Flower Song" and the outpourings of a Jazz Palais. No offence meant to the young men!

#### That L.O. Wavelength.

3LO, after months of lingering on the longer waves, now wants to loiter a while on the shorter, and because of adverse criticisms it invited representatives of the Press (excluding this present one) to hear words of wisdom from its Technical Adviser. From published reports of this interview it appears that with a wavelength of 400 metres there would be an intensity ten times greater than with the present length of 1720 metres, which practically means that it would be equivalent to another valve being added to nearby receiving sets, but not necessarily as great a proportional increase in distant reception. The mystery is why all this was not thought of when 3LO was started. The B.B.C. stations are now being quoted in extenuation of the proposed change, and so are, of course, the stations of U.S.A.; but all these were in existence before 3LO was thought of, so why worry? It was cheerfully admitted that selectivity on crystal sets will suffer (by which, of course, is meant any sets using inefficient slider tuners, since the crystal is not any less selective than a valve), but apparently the number of crystal users in Melbourne is not sufficient to influence the decisions of a great public undertaking. Meanwhile, one awaits some official utterance from the P.M.G. on the subject.

#### 3 'Armonics.

A little tintinnabulation up near 2FC and quite a tune-in-able whistle adjacent to KDKA still indicate, to the searcher, that 3AR is anxious to oblige on all wave bands, whether he likes it or not. The question raised by these misplaced attentions must inevitably be whether 3LO on coming down to a lower wavelength will also behave in like manner. With due respect to technical advisers and other desirable adjuncts to broadcasting, it is as well that the non-technical public should know that the nearer the wavelength gets to the fundamental of the aerial, the more likely it is to have powerful harmonics, and if 3LO and 3AR conspire together to "jam," "blanket," and "heterodyne" one another, not only fundamentally, but unharmonically, the result will be language distressing to ears polite.

#### 3LO.

3LO could with advantage look into other matters besides the length of the waves it uses. The transmission of "Betty" was very good in parts, but the microphone on the stage should be cautioned not to join in the dancing that listeners-in assume to accompany the songs, but object to being made painfully aware of it by the music breaking off into "physical jerks." Worse still was the very long delay in transmitting the Musical Society's programme last Saturday. But the most unkindest cut of all was the entire absence of Sarcoli's violin recital from Sunday night's programme, when the disappointment was accentuated by no explanation from the announcer. It would be an act of grace if 3LO would kindly tell us why these little accidents occur, WHEN they occur.

#### 3AR.

Listeners-in who persist in tuning-in to 3AR, in spite of repeated incentives to neglect doing so, received their just reward on Sunday night when the Church of Christ was brought into hundreds of fortunate homes by medium of this much-abused station. Around the metropolis 3AR was actually louder than 3LO, and the modulation and tone left little to be desired, except that it should always remain so. The adjournment to the studio brought back again the same intolerable hum and the same old tinny voice production that listeners-in have learned to dread. 3AR is a plucky little station, and deserves better days. Its programmes look so well in print, but, oh! that that too-dreadful hum would cease!

#### 3LO (VE) Has a Fly.

With his life in one hand and a portable set of his own recent construction in the other, the intrepid president of the W.I.A. (V.D.) stepped aboard an

(Continued on Page 26.)



# Wiles' Wonderful

56-62 GOULBURN ST. (1 door from Pitt St.)

384 PITT ST. (near Goulburn St.)

SAME QUALITY. SAME PRICES.

Established Over 20 Years.

Have the pleasure of making your own Radio Set in a few hours of your spare time, with a screw driver, pliers, and soldering iron, and spend a thoroughly enjoyable evening putting together these famous sets.

Only the best quality parts are supplied, including Bakelite Panel drilled and engraved. The Accessories include Dry Cell Valves, Batteries, Headphones, Soldering Iron, Solder, Screws, and Instructions for Assembling and Operating, which are so clear that you cannot go wrong.

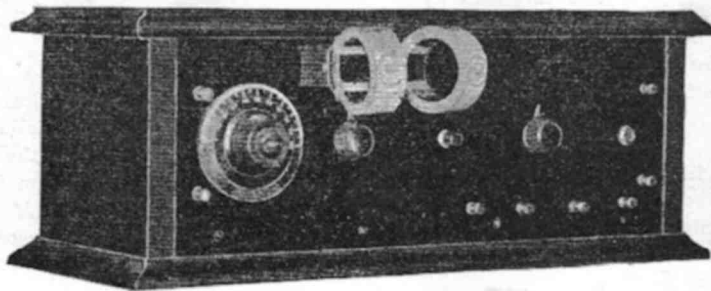

Illustration of 3 Valve Set constructed from advertised parts.

### Prices

Complete Parts for 1 Valve Set	£6 8 1
Maple Cabinet for 1 Valve Set	1 5 0
Complete Parts for 2 Valve Set	9 17 4
Maple Cabinet for 2 Valve Set	1 5 0
Complete Parts for 3 Valve Set	12 13 4
Maple Cabinet for 3 Valve Set	1 10 0
Complete Parts for 4 Valve Set	17 3 3
Maple Cabinet for 4 Valve Set	2 5 0

## Western Electric Loud Speaker

Model 4003

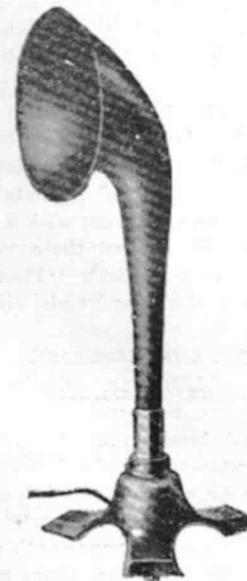

Price, £2/19/6.

This compact speaker is designed to meet the need for a simple radio loud speaking device to entertain a group of people in an average size room. The horn is constructed of neat paper composition, black finish, and is detachable from the base.

Mail Order Dept.

60 Goulburn St.

Write for Price List now, R6.

Amplifier

Reproduction of speech with to head volume is instrument v principle.

The desired tone and volume is achieved by the use of a neodymium connector which produces a resonance in the duct. Another feature.

This is a telephone, machine can enjoy headphones

OUR GUARANTEE: It is our intention that every article listed herein shall be truthfully described. Therefore, we guarantee you take no risks whatever in sending us your order, for, unless you are completely satisfied with the goods and your saving, you promptly return your money and all transportation charges you have paid. The articles enumerated above are only portion of our

# Powerful Wireless

10, F. (near Goulburn St.)

23 PITT ST. (Near CIRCULAR QUAY).

PRICES. SAME SERVICE.

20 Years.

## Amplion Music Master

MODEL AR15.

Price, £9/-.

Reproduces Radio music and speech with a fidelity comparable to head telephones, while the volume is unusually loud for an instrument working on the telephonic principle.

The design provides an enamelled tone arm of standard steel, a polished oak trumpet, and rubber connector eliminating all undue resonance in the entire sound conduit. An exclusive "Amplion" feature.



## Amplion Gramophone Attachment

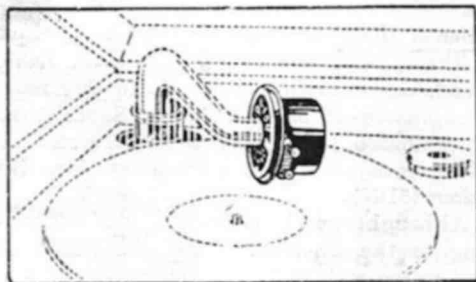

Price, £4/-.

This little device, when attached to the tone arm of a gramophone, makes a most effective loud speaker for radio. Everyone can enjoy the wireless reproduction without the use of individual headphones.

We guarantee every article you buy from us to be satisfactory in every detail. For your saving, you may send back everything you buy from us, and we will refund a portion of our price list R6.

## Amplion Dragon

MODEL AR19.

Price, £8/-.



This revised home table type speaker is one of the best known Amplion Models. It is one of the most useful models for home use, being fitted with non-resonating Sound Conduit with oak trumpet hinged to the weighted electroplated base, allowing the horn to be tilted to any desired angle.



## Amplion Dragon Fly

MODEL AR102.

Price, £2/-.

This little instrument is the very latest in Loud Speakers, and is now being marketed for the first time. It has been perfected after many years of experiment and research on the part of Wireless experts, and is an absolute revelation in the purity of tone. Although astonishingly small and compact, the results to be obtained from it are as near perfection as it is possible to reach at the present stage of scientific progress.

(Continued from Page 23.)

aeroplane, and as the flimsy vessel soared aloft into the blue immensities he spoke eloquently into the microphone of what he saw or imagined on his flight. Marvellous Melbourne lay below him spread out like a map. But let him tell all about it himself: Deep down below, in a corner of St. Kilda, Mr. Hull at 3JU picked up the words of Love as they fell from the ether and handed them on to 3LO, who broadcast them to the listening multitudes that knocked off work at 1.30 on Friday afternoon to hear all about it, or wrote to the papers pretending they did. Exactly what it had to do with the Wireless Institute it is hard to determine. Wireless telephony from an aeroplane is no novelty. It became commonplace during the Great War; but, of course, the Institute has to live up to its reputation of trying out with a flourish of trumpets this year what ordinary operators did as a matter of course years ago. It is no doubt interesting to learn that Mr. Love has made a portable set that will work, and let us all hope he gets the prize offered at the Wireless Exhibition in that class. But that should really be his own affair, and why put the blame on the Institute?

When other members do smart things they very properly get all the credit themselves, and there is no reason why all the limelight in this instance should be turned on the Institute. Mr. Love is not the man to shirk publicity when his presidential duties call him, but self-abnegation can go too far, and it is an open secret that Mr. Love was so manifestly the one and only man for the job that nobody else in the Institute got within coo-ee of it. Probably no other member had ever even entered an aeroplane nor was at all accustomed to descriptive oratory of the sort required, and had Mr. Love not stepped into the breach the bottom would have fallen out of it. As every policeman knows, it is much harder to transmit from a motor-car travelling along suburban roads, so the Institute very wisely decided not to try an experiment whose failure might have put back the progress of the Wireless Police for years, but doubtless after Police Constable X.DX has demonstrated the feasibility of transmitting from a motor-car at full speed, the Wireless Institute will take the matter up and confirm what has already been established. It is in ways like these that the vigorous Institute forms, as it were, the rearguard of scientific progress, and encourages every schoolboy to hope that he, too, will be president when Mr. Love gets tired of it. The dogged persistence of the president is shown by the report that after several days of successful preliminary testing he did not give up on the Day of Days when he was forced to "descend to make an adjustment."

## SOUTH AUSTRALIA. Central Broadcasters Ltd.

The outlook for broadcasting in South Australia has shown decided improvement during the last two weeks. Enough capital has been subscribed to enable the company to go to allotment. This means that the company should be in a position to take immediate steps for the installation of the transmitting plant.

The transmissions from this station have of late shown great improvement, and numbers of reports are daily being received from wireless enthusiasts from all over the Commonwealth, complimenting them upon their excellent performances.

Their broadcasting of the church services on Sunday evenings are a complete success, and these services are eagerly looked forward to by large numbers who do not attend church.

On Tuesday evening the orchestral music from the "Palais Royal" was broadcasted from the Grosvenor, a land line having been erected connecting up these two buildings.

The Palais Royal has a Jazz orchestra which can hold its own with any orchestra of its kind in Australia, and the broadcasting of its performances was a welcome change from the studio concerts which have up till now been the order of the day.

It is the intention of Central Broadcasters, it is believed, to broadcast at least once a week from the Palais.

The broadcasting of these items last Tuesday evening was carried out splendidly. Everything was clearly audible, including the buzz of voices and the hand-clapping at the conclusion of each item.

### Station 5 DON N.

The opening of the All Australian Exhibition in Adelaide on Friday week was another milestone in the history of broadcasting in South Australia. The exhibition was opened by the Prime Minister whose speech was broadcasted by Mr. Hume's Station (5DN).

Although great difficulty was experienced owing to the machinery and the noises of the crowd in the main hall everything went off smoothly and successfully. The transmission was good and had plenty of volume. The speakers' voices came through very clearly and were easily understood. A public address system was also installed to enable the crowds outside the hall to hear the speeches. The music and speeches from the loud speakers could be heard very distinctly for a great distance all over the Exhibition grounds.

Every Wednesday and Saturday evening con-

certs are being broadcasted by this station from the Exhibition, and the success of these concerts is in no small way due to the untiring energy and enthusiasm of Mrs. Hume who is forever busy arranging musical programmes.

Last Monday evening 5DN broadcasted a concert from the Adelaide Conservatorium. This was the first of a series to be given during the year. **An Extraordinary Wireless Demonstration.**

At about 1.30 p.m. on Friday (Adelaide time), while Mr. A. W. Jarrett, a director of the Millswood Auto and Radio Company Ltd., was listening in to Melbourne on a four-valve set, an announcement was received that a demonstration was about to be given from an aeroplane while flying over Melbourne. This was the first demonstration, and the voice and articulation of the speaker were very good, only a few of his words being drowned by the noise of the engine of the plane. The second demonstration was given at 3 p.m. when the speaker was announcing each suburb of Melbourne over which plane was flying at the time. This second demonstration was of excellent nature, the voice and words being very clear, so that had a listener-in a knowledge of Melbourne and its suburbs, the direction of the aeroplane could have been followed with ease.

It is a very remarkable feat for the first time of demonstrating and the operators of the transmitting station and the persons responsible for

the successful carrying out of the demonstration are to be highly commended.

#### AMONG THE EXPERIMENTERS.

##### 5DA's Signals Reach Finland.

Mr. S. R. Buckerfield, (5DA), has received a report from Mr K. S. Sainio, S.R., A.L., Naval Station 2NM, Merikatu, 3A Helsinki, Suomi, Finland. Mr. Buckerfield was recently reported successful in working two-way with America, and according to a DX card received last week, it was the same transmission that reached Finland.

##### 5BG Reaches France.

Mr Harry Kauper has been doing some good work during the last few weeks. He has received a card from Mr. F. C. Studley, of Harrow, Middlesex, England. Mr. Studley receives A5BG on 85 metres at strength 3 on one valve. A card has also been received from A2CM reporting 5BG's signals being heard in Macao, not far from Hongkong, China. Another card comes from U.S.A., namely 9CWX, of Missouri.

Numbers of interstates are being heard every evening on short waves but very little is heard from the Western State, A6AG being the strongest of these. A6BO has not been heard lately.

On the longer waves the interstate broadcasters are coming in at very good strength, and many listeners-in prefer to tune their sets to these stations rather than listen to the local stations.

## Ramsay Radio Receivers & Supplies

43 plate Magnus Condensers, plain ..	17/6
23 plate Magnus Condensers, plain ..	13/6
46 plate Magnus Condensers, vernier ..	22/6
26 plate Magnus Condensers, vernier ..	18/-
Parts for .0005 Plain Condensers ..	7/6
Parts for .001 Plain Condensers ..	10/-
3 Gang Magnus Bakelite Sockets ..	12/6
Bakelite Knob for Rheostats ..	1/3

4in. Bakelite Dials ..	3/-
Buck's English Transformers ..	12/6
Powerquip English Transformers ..	18/6
Marco Transformers ..	32/6
Polar 2 coil Vernier Mounting ..	10/6
Pranco 2 coil Vernier Mounting ..	15/-
Brandes 4000 ohms Head Phones ..	35/-
H.C. Coil Plugs ..	2/3

FULL RANGES OF RADIOKES AND ATLAS HONEYCOMB COILS AND LOW LOSS COILS ALWAYS IN STOCK.

## Ramsay Sharp and Company Limited

Radio Engineers

217 George Street, Sydney



## A Single Stage Radio Frequency Amplifier of Unique Design

By W. A. STEWART.

**T**HE amplifier about to be described is of quite a novel design, and embodies a stage of tuned, neutralised, radio frequency amplification, and also regeneration. The circuit as depicted in Fig. 1 is a standard one, the only difference being in the tuning coils. The transformer and tuning coils have been developed after much experimentation by experts in America, and it really does all that is claimed for it. It will work decently with a very short aerial, or, in most cases, none at all.

We will first of all consider the tuning coils and radio transformer. The aerial coil is built in the following manner: On a three inch tube wind 50 turns of 20 d.c.c. wire, with a tap at the 25th turn. The secondary of the radio transformer is wound on another three inch former, and is composed of 77 turns of 20 d.c.c. The primary of the transformer is somewhat different, it being wound in a slot one-eighth inch wide by one-eighth inch deep in a piece of wood which will just fit in the end of the three inch tube. There are 24 turns of 30 d.c.c. wire in the primary. The neutralising condenser (N.C.) is connected to the 18th turn of the secondary. The pri-

The tuning is effected by two .0005 variable condensers, and they must be of good design, as the tuning is very sharp. A condenser with a mechanical vernier arrangement is an advantage, as it simplifies tuning. The coils are mounted at right angles to each other, and with a little ingenuity they can be mounted on the back of the tuning condenser. The wavelength range of the set is from 200 to 600 metres approx. This means that you cannot get 2FC or 3LO, but there are plenty of stations in the band of wavelengths that will come in quite well. The aerial is connected through a .0001 fixed condenser to the tap at the 25th turn on the aerial, this condenser giving constant aerial tuning, which means the tuning is always the same, no matter what size aerial is used. The neutralising condenser is made as follows: On a small piece of insulating material about 6in. x  $\frac{1}{2}$ in. drill two holes, one each end. Next get two pieces of 16 bare copper wire and fasten each round a screw to fit in the holes all ready drilled. Fasten the screws in the holes, and cut the pieces of wire so that the ends are about a quarter of an inch apart. Over the wires slip a piece of

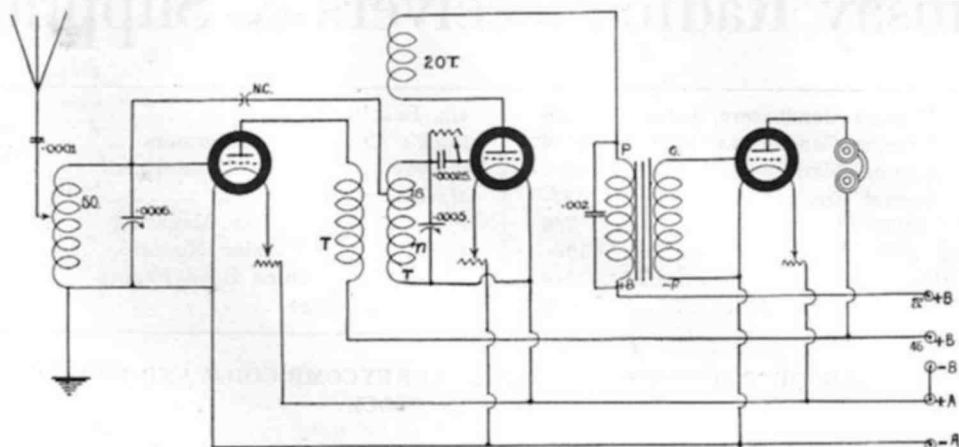

FIG 1.

mary wound on the piece of wood is placed in the end of the tube nearest to the neutralising tap. In the other end there is an ordinary wooden rotor for regeneration. It is wound with 20 turns of 30 d.c.c.

spaghetti tubing, and over this again a piece of brass tubing about three inches long. The connections are then made to the two screws, and the condenser is connected between the 18th turn on the radio trans-

former and the grid of the first valve. (See Fig. 2.) The fixed condenser across the primary of the transformer is of .002 capacity, and is a radio frequency by-pass condenser.

Next move the small brass tube on the neutralising condenser until the signal dies right out, or becomes very weak. It is advisable to move the tube with a rod of some insulating material, so that body cap-

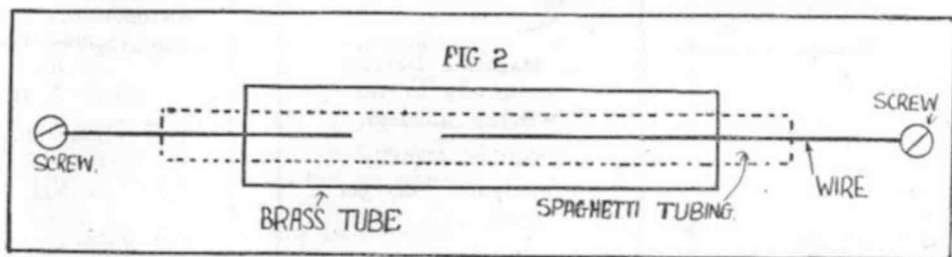

After the set has been wired up correctly, the first job is to neutralise it. When the tickler is rotated there should be a click denoting oscillations. This shows that the tickler is making the radio frequency oscillate, and it is these oscillations we have to neutralise, so as to make the set easy to handle, and also to stop it sending out a strong howl or whistle. To neutralise the set, tune a loud station in, such as 2BL. Then remove the first valve, place a piece of paper on one of the filament prongs of the socket, and replace the tube. Of course, the filament does not light, but the signal is still heard, due to the inter electrode capacity of the valve.

acity effects will be minimised. You will find the position critical, but once it is adjusted it can be left. Now remove the paper, replace the tube, and the set is ready to use.

You will find the tuning rather sharp, and the regeneration control will make a big difference to the volume, particularly on weak stations. UV199 or 201A valves are recommended, and if the set is properly built you will be surprised at its selectivity and sensitivity. With a single stage of audio as shown, little difficulty should be experienced in working a loud speaker off most stations without an aerial or with a very short one.

## A Simple "Three Choice" Switch

**M**ANY receivers are designed with a multiplicity of terminals to afford choice of aerial tuning or of value of variable condensers. The simple type of switch described may, however, be used if preferred to give the same results with less expenditure of time and trouble. It consists merely of an ordinary S.P.D.T. switch with an extra arm mounted in line with the other three components.

For the alternatives of A.T.C. in parallel, series, or "constant aerial" tuning, the arrangement is as Fig. 1, where it will be seen that with the arms joining A B and C D we have, say .0005

mfd, in parallel with A.T.I., with B c only joined we have .0006 in series, (the increase in maximum and minimum is of advantage here), and with C D only the "constant aerial" tuning of .0001 in series and .0005 in parallel.

Similarly, to combine a fixed and variable condenser to give different maximum values, as in Fig. 2, it will be seen that joining B C gives .00025, A B .0005, and A B, C D .001. The only precaution necessary is to see that the handles on the switch arms are not too long to fit down between adjacent contacts, thus the handle on arm A must be able to fit down between B and C, and that on C between A and B.

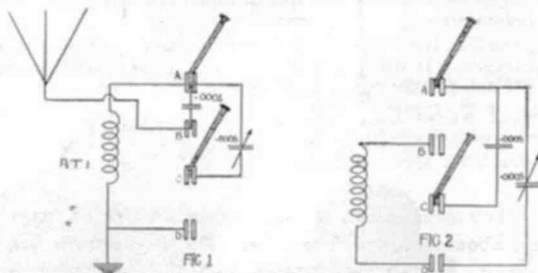

## FAMOUS NEWTOWN BAND ART UNION.

We have been asked by the Newtown Band Committee to draw the attention of those of our readers who have tickets for sale in the above art union to the fact that the sale of these tickets positively closes on the 14th of this month, and should suggest they send their cash and butts of tickets so that they will reach the secretary not later than the 26th April, 1925.

# HOWELL'S Sale & Exchange

FOR  
THE LATEST  
AND  
BEST  
IN  
WIRELESS  
AT  
LOWEST  
PRICES

19 Barlow Street  
SYDNEY

PHONE: M A 1133  
OPEN TILL 9.30 FRIDAY NIGHT

# QST

A Magazine Devoted  
Exclusively to the  
Wireless Amateur.  
Published Monthly.  
Subscription, 18/- per  
annum, post free.

Distributor for Australia:

**Phil RENSHAW**  
DALTON HOUSE,  
115 Pitt Street, Sydney  
Box 2816, G.P.O., Sydney.

# VACUUM TUBES

In Wireless Communication  
A Practical Text Book  
for operators and experi-  
menters

By  
Elmer E. Bucher

This volume shows over  
140 different circuits for  
the practical use of  
vacuum tubes as detec-  
tors Radio or Audio Fre-  
quency Amplifiers, Re-  
generative receivers  
Beat Receivers, etc.

Price 12/6, Postage 8d.

N.S.W. Bookstall Co. Ltd.  
Corner, Castlereagh and  
Market Streets,  
Sydney.

## "RADION" Panels and Parts meet every require- ment of the radio set builder

There are many reasons why you should build your radio receiving set with Radion panels and parts.

*First:* Radion has proven beyond a doubt to be the supreme insulation. It is made exclusively for radio work and far excels any other material in the four main characteristics required for wireless, namely, low angle phase difference; low dielectric constant; high resistivity and the low absorption of moisture.

*Second:* Radion is easily worked. It can be sawed, drilled, machined and otherwise worked without the slightest danger of chipping or cracking.

*Third:* Radion Mahogany Panels have the actual surface graining of fine, highly polished mahogany while black Radion panels have a beautiful ebony finish.

*Fourth:* In cost, Radion is far more economical than any other material.

*Fifth:* Sets made with Radion Panels and Parts will give much better satisfaction.

Do not jeopardize the value of your receiving set by using cheap, trashy materials. It will pay you to always insist upon genuine Radion. — Look for the name stamped on every piece.

International Radio Co., Ltd.  
91-92 Courtenay Pl., Wellington N. Z.  
200 Castlereagh St., Sydney, N.S.W.



" Got It at Smith's "

**CHEAP!** Look in Our Windows

**SMITH'S**  
RADIO STORES

3 VICTORIA ARCADE :: (Opp. Hotel Australia)

25s. each



.. MADE BY ..

**De Forest**

THE MAN WHO INVENTED BROADCASTING

**DE FOREST VALVES**

TYPE D.V.2—Takes 5 Volts at  $\frac{1}{4}$  Amp. on Filament . . . . . 25/- each  
Plate Voltages, Detector .. 18-22 $\frac{1}{2}$  Volts  
Plate Voltages, Amplifier 60-150 Volts

TYPE D.V.3—Takes 3 Volts at .06 of an Amp. on Filament . . . . . 25/- each  
Plate Voltage, 16-22 $\frac{1}{2}$  Volts, Detector  
Plate Voltage, 60-120 Volts, used as an Amplifier.

Both Types Fit Standard American Socket.

D.V.3                      D.V.2  
Filament, 3 volts      Filament 5 volts  
.06 amp.                .25 amp.  
Both Types Fit Standard American Socket.

(Wholesale Only)

**INTERNATIONAL RADIO CO. LTD.**

200 Castlereagh Street Sydney, N.S.W.      Phone: MA 1387

Also at 91-93 Courtney Place, Wellington, N.Z.



## Information

Conducted every week. Except in the case of subscribers a fee of 1/- is charged for not more than four questions. Questions will be answered by mail in the order of priority, and when considered of sufficient general interest, will be published under this heading.

F.M. (Rockhampton) states he is not getting the results he should with his one valve receiver, and asks (1) What is the detuning coil for and why the tappings? (2) What is the process of tuning? (3) Will a .001 condenser stripped to 6 fixed plates and 5 movable function O.K. as a .00025?

A.: Apparently you refer to the Reinartz. (1) The detuning coil will not alter your wavelength. You should wind several coils if you wish to receive on the higher wavelengths. See reply to H.C.L. in "Wireless Weekly," March 20th. (2) Using 9-27-9 in the main tuning coil, you should receive wavelengths up to approximately 400 metres. Turn the primary condenser dial gradually from minimum to maximum positions. As soon as the carrier wave is heard a slight movement of your other condenser will bring in the music or voice. A 40-120-4 coil will cover 2FC's wavelength. (3) We don't advise you to strip down your .001, as a good .00025 is fairly cheap.

D.H. (Sydney states he constructed the Reinartz described in "Wireless Weekly," Sept. 5th, 1924, except that he used a 23 plate instead of the 11 plate variable condenser across the main tuning coil. Using a main tuning coil of 9-27-9 turns the set oscillates well between 200 and 500 metres, but outside this, results are poor. 2FC comes in fairly well using a 40-120-40, but seems to lack volume. Aerial is 55 feet double inverted L, with 30 feet lead-in. A.W.A. 33 valve, grid leak, 2 megohms and condenser .00025 mfd., 42 volts on the plate and 4½ volts through a 30 ohm rheostat for the filament.

A.: It is quite O.K. to use a 23 plate in lieu of an 11 plate condenser. Your best plan is to wind several coils, using the formula 1-3-1 (see answer to H.C.L., "W.W.," March 20th). The Reinartz is very satisfactory on the higher waves, providing too much capacity is not used across the main tuning coil. If you have a series of coils you will readily see that the most satisfactory is the one which enables you to use the smallest amount of your 23 plate condenser for the particular wave you wish to tune. Check your A and B battery voltages. You may find a fault here.

R.H.C. (Collarenebr) states he is using an ordinary 3 coil circuit with detector and two audio, which does not give quite sufficient volume for effi-

cient loud speaker results. Would an extra stage of audio or a stage of push pull give better results? He asks for particulars of push pull.

A.: An article on push pull was published in "W.W.," October 3rd. It is the only form of audio amplification you could add to your present set. Briefly the circuit is so arranged that two valves are placed in parallel, the grid of each valve being connected to the opposite ends of the secondary winding of the input transformer. The centre of the winding is then connected to the negative of a "C" battery, the positive of which is connected to the negative of "A" battery. By this means the grid of each valve is exactly out of phase, or in other words one valve is in operation during one half of the cycle and the other valve functions during the other half. This action therefore balances and neutralises all distortion. However, we would advise you to add another stage of high frequency before your detector, as this will give you louder signals and increased range. Another audio stage is not practicable (except push pull. See elsewhere in this issue article on a four valve receiver.

S.R. (Hillston, N.S.W.).—Q1.: Am using the ST100 with two valves, Phillips D11, and about 75 volts on the plate. They are marked 30-75. Can I put 100 on? (2) Could a series parallel switch be used on aerial coil? (3) Is 2 mfd. too high capacity for the blocking condenser across the "B" battery?

A1.: Yes, quite O.K. (2) Yes, but it is not advisable. Suggest you wind a few small coils yourself or place a .0005 condenser in series with your aerial when you wish to get down to low wavelengths. (3) 2 mfd. is O.K.

W.E.R. (Cessnock).

Question: Please supply me with the formula enabling me to arrive at the number of turns for coils for different wavelengths.

Answer: The formula is as follows:—

R.T.:K

Inductance =  $\frac{R.T.:K}{1000}$  = mics.

1000

Where R=Radius in Cms.

T=Number of turns.

Radius.

K=

Length of winding in cms.

1000 is a permanent factor.

This formula will give you the inductive value in mics. The capacity of the coil varies with different types of winding, therefore the wavelength covered by the coil will vary with the type of winding.



## Burginphone Model 8 4 Valve Receiver £45

Complete with all Accessories and Loud Speaker  
£72

The result of years of actual experience in manufacturing broadcast receivers for Australian conditions. We have conducted tests throughout Victoria, N.S.W. and Queensland, and this Burginphone model 8 has passed with honors.

At Exeter, N.S.W., the Perth station 6WF and KGO the Californian station are heard often

Full particulars on application.

**Burgin Electric Co. Ltd.**  
Wireless Manufacturers & Suppliers  
340 KENT STREET, SYDNEY

## Columbia Dry Cell

"A" Radio Battery No. 6111



**D**ESIGNED especially for use in connection with dry cell vacuum tubes. Lasts much longer and gives more power for this purpose than any other dry battery.

Use only

## Columbia Radio Batteries

Made by the manufacturers of the Famous Columbia Dry Cell

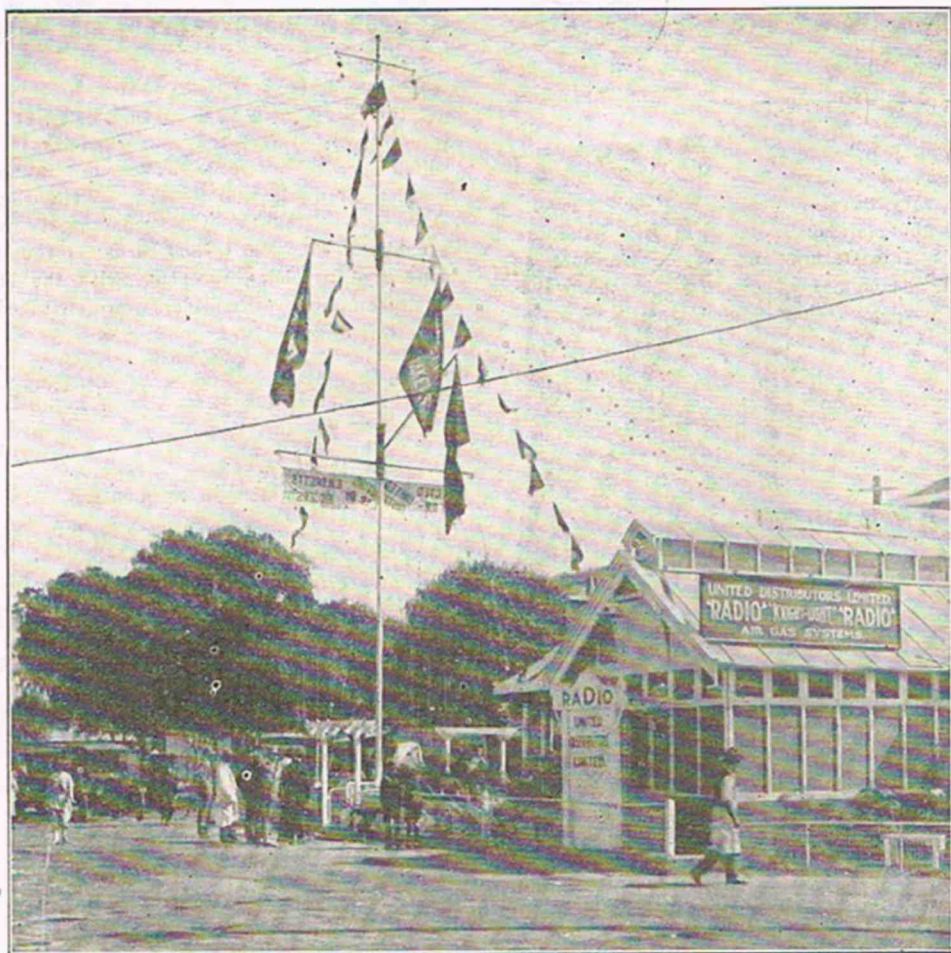

UNITED DISTRIBUTORS' LTD. EXHIBITION AT ROYAL AGRICULTURAL SHOW.

**A**T the junction of Loftus Street and Park Road, amongst the shrubs and flowers grown by Searls, a most interesting demonstration of radio broadcast reception was carried out by the United Distributors Ltd.

Broadcasting was picked up on an aerial system supported by an 84-foot mast of latest design, erected by Brett and Sons, of Balmain. The signals picked up by this aerial were received on one of the United Distributors' Ltd. "Beard De Luxe" five valve sets, and then amplified by special tone amplifiers, using 25 or 26 valves, until they were of sufficient strength to work 24 speakers, suitably placed around the enclosure. The result was interesting as showing what

a large volume of pure sound can be obtained by modern methods of broadcast reception.

The adaptability of radio broadcasting for addressing large crowds was here illustrated, probably for the first time in Australia, and suggests methods of employing radio broadcast receivers not yet fully recognised in Australia.

In the summer-house adjoining was an interesting display of both completed sets and parts, as recommended and supplied by the United Distributors Ltd. The display was of interest to the purchaser of a crystal set, the De Luxe set, or to the experimenter who wishes to purchase reliable parts for his own construction.

## Further Notes on the Reinartz

By W.J.T.

THE notes on the Reinartz All Wave tuner by "G.W.S." in your issue of April 3rd are very instructive, and as I am sure there are by now a great number of users of this excellent circuit, particularly on short waves, any further notes will be welcomed. My offering deals with the band between 60 and 100 metres. Included in this band are the Americans, Interstaters, and New Zealanders, as well as strong harmonics of one half of the wavelength used by some other transmitters. For instance, 2DE transmitting on 185 metres is stronger on a harmonic at 92½ metres than at 185 metres. Using a jumble wound coil the set would only oscillate in patches on this band, and then only slightly. Stations received on C.W. were very scarce, but when a space-wound low loss coil was substituted the air suddenly became alive with signals.

My aerial is 80 feet single wire, with 30 feet lead in. The coil used is space-wound with No. 18 d.c.c. wire on a 3¼ in. former, the number of turns

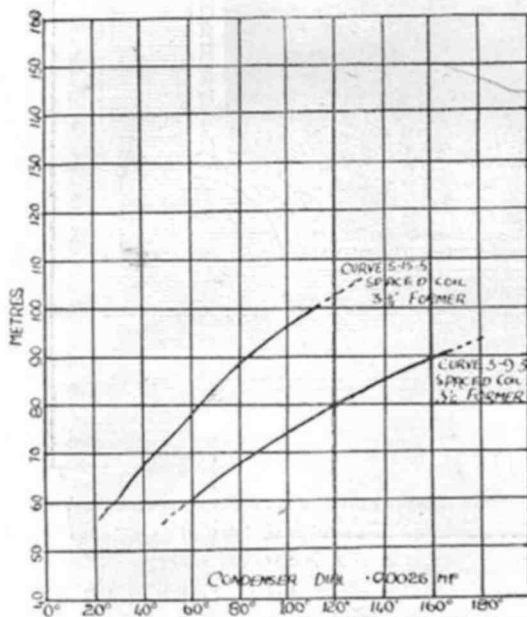

being 5-15-5; turns are spaced from one another by a lacing of string to four points. No. 16 wire makes a firmer job. The aerial tuning condenser is a .00025 Cardwell low loss, and the reaction condenser a New York coil .0005 low loss. The curve of this coil compiled from the standard transmissions by 2CX is enclosed. The tuning condenser reading for 60 metres was 30, and for 100 metres was 114 with the same

coil. The set would oscillate nearly down to 50 metres and up to 110 metres. The difference in the range of my 5-15-5 coil on a 3¼ in. former as compared with that of "G.W.S." on a 2¼ in. former is remarkable, his range being from 100 to 230 metres, whilst mine is about 50 metres to 110 metres. To get the receiver to oscillate on the lower wavelengths it seems essential to cut out capacity in the coil itself. The coil seems to have more influence in this respect than the condenser. With regard to the choke coil, I have noticed that most circuits using a choke specify 200 to 300 turns. I found very little difference to phone reception with the larger choke, but when the two amplifiers were switched in, squealing in the amplifying valves was very bad. As a matter of fact, when using the 75 turn choke, the amplifiers squeal if more than 40 volts are used on the plate. The use of a bias battery only made more noise. The valves used were C.299. Perhaps some other fan may be able to give information on this department of this very interesting set.

[Editor's Note.—We shall be glad to publish the experiences of other readers with this circuit.]

The golf-bug and the radio-bug have joined forces, creating a new urge in the breasts of radio listeners in the western part of the United States and Canada.

This is evidenced to-day by a flood of mail which is pouring into KGO from radio listeners who want to learn how to play golf over the air. Joe Novak, professional player and teacher, is giving a series of lessons over KGO on Thursday evening at 7.15, and listeners have been requested to send in for charts showing fundamental positions of the club and body, which he will use in the course of his talks.

While most of the requests for radio golf charts are coming from cities, many are being received from farmers and others in small towns and communities. Even from points in Canada, where the snow is still on the ground, hundreds of letters are being received.

During recent tests in the KGO studio, when a window was left open, a sensitive condenser microphone picked up the song of a meadow-lark observed to be in a field about 300 yards away from the studio building. The bird's song came through clear and sweet, and possessed life-like qualities.

KGO control room operators explained that by turning a dial the meadow-lark's song could be amplified sufficiently so that when broadcast it might easily be heard over several States. For normal broadcasting, however, sounds of this intensity are not amplified as much as during tests.

Where there's Wireless — There's Wireless Weekly



AMPLION

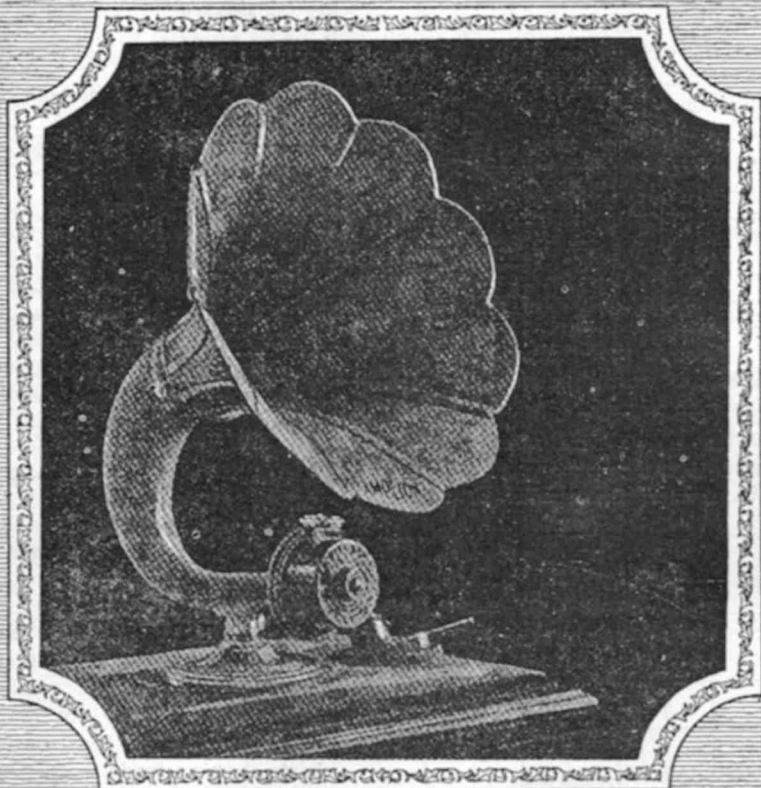

## *Amplion*

### THE LOUD SPEAKER SUPERLATIVE

Amplion Loud Speakers are world-famous for sensitivity, full volume, clarity, and wonderfully natural tone—qualities due to the incorporation of many exclusive features, including a non-resonating sound conduit with wood horn and an improved unit embodying "floating" diaphragm.

"Dragon" type, AR19, as illustrated, £8.

Sole Australasian Agents:  
AMALGAMATED WIRELESS (A/SIA) LIMITED



## Wecovalves now reduced to 25/-

**F**IRST favourites, either for use as detectors, high frequency amplifiers, or low frequency amplifiers, Wecovalves at the new price are unusually economical. Especially when cheapness is judged solely in relation to durability and high efficiency.

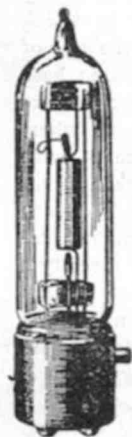

Wecovalves are robust, yet most delicately adjusted. They improve the reproduction of any properly constructed set. They simplify its operation since no accumulators are necessary—Wecovalves work on dry cells.

*The top illustration shows a Wecovalve, actual size. The lower one a Wecovalve Socket. Both Wecovalves and Sockets may be obtained from all radio dealers.*

### Western Electric Company (Australia) Ltd.

192-4 CASTLEREAGH ST., SYDNEY. Phone: City 336, 355 and 356  
And 588 BOURKE ST., MELBOURNE. Phone: Central 8336 and 8949

R 255

A decorative banner with a zigzag line pattern and the letters 'WE' in a large, stylized, outlined font in the center.

Before you  
Expend  
Money on  
Radio  
Equipment  
Consult  
Anthony  
Horderns'  
Wireless  
Experts.

Your inspection of the big display of everything that is new in the world of Wireless, is invited.

(Wireless -- Second  
Floor)

Anthony Hordern & Sons  
Limited,

Brickfield Hill, Sydney

Phone City 9440.

Box 2712 G.P.O.

## Club Notes

*Continued from page 11*

### MARRICKVILLE AND DISTRICT RADIO CLUB.\*

The usual weekly meeting of members of the above club was held at Marrickville School of Arts on Monday night, 16th March, 1925.

There was a good attendance of members, the chair being taken by the vice-president, Mr. McQuoid.

The principal business of the night was a discussion on English versus American valves, in which the members present all joined, and with the aid of the club's set a demonstration was given, using both makes. Same proved of considerable interest, more especially to the younger members, some of whom are naturally not in a position to experiment with some of the various well-known high-priced valves in general use.

The attention of members was drawn to the "All Clubs' Night" to be held at the Royal Society's Rooms on Monday, March 30th, 1925. All present expressed a desire to attend the function, as the films to be shown promise to be of considerable interest to those who are keen on the study of wireless.

Buzzer practice concluded an enjoyable evening.

The secretary of the club, Mr. A. W. Hemming, of 23 Central Avenue, Marrickville, will be pleased to hear from enthusiasts who wish to become members, and visiting members of other clubs are always welcome.

J. H. MARTIN, Publicity Officer.

### RADIO INSTITUTE ESTABLISHED BY DE FOREST CO.

**A**NNOUNCEMENT has been made by the De Forest Radio Co., Jersey City, U.S.A., of its completed plan for the De Forest Radio Institute, to be immediately inaugurated with an enrolment provided for more than 5000 students in the personnel of more than 2000 authorised De Forest dealers in the United States. The De Forest Institute is the first concrete recognition among the leading manufacturers in the industry that advanced courses in both merchandising and service were needed to equip retailers for the most efficient contact with the ultimate consumers of radio's highly specialised products.

This completed plan is the fruition of a country-wide survey into the daily problems of thousands of radio distributors, retailers, repair and servicing factors with analysis of the most practical method of meeting, or the solution of, problems that arise as well as research into practically every product

of the industry. Public demand this survey developed has, and is far surpassing the retail equipment that would intelligently service the amateur radio purchaser, who up to the present time has been largely selling himself; it also developed the need in radio retailing of specialists to successfully demand men with a proper conception and belief in the future of the radio art.

William H. Lough, formerly Professor of Economics, New York University, and Vice President Alexander Hamilton Institute, now President of the Business Training Corp., has been appointed organiser of the De Forest Radio Institute with a faculty that includes some of the foremost radio engineering experts in the industry assigned from the De Forest Co.'s technical staff, in addition to a number of merchandising and sales experts from the Business Training Corp., selected because of their special ability to successfully handle special educational problems of industrial concerns by correspondence.

Practically every problem of radio merchandising and servicing, culled from the exhaustive reports of thirty De Forest factory service men in daily contact with the retail radio trade in every State in the Union, has been made the basis of intensive research, and the completed initial course has been prepared in simple and untechnical language that will cover the first three months of study for those enrolled.

One of the primary purposes of the De Forest Radio Institute's course is to provide practical knowledge of radio as it is needed by the average music, phonograph, electrical, furniture and other dealers and their salesmen, not radio specialists, but who have added radio departments to their stores, and who desire to serve most efficiently the requirements of their own communities.

An interesting item of news comes from Acton, England, where young Guy Vandervell, son of C.A.V., has been appointed head of the newly-established wireless department. It was largely owing to Vandervell, Junior, that wireless was ever taken up seriously by the famous old firm, and it has certainly redounded to his judgment, for the loud speaker and batteries are as well known and as popular as any on the market. Tony Vandervell, as he is known, is of course the well-known racing motorist, and has many victories to his credit at Brooklands and elsewhere; he is extremely popular at the works, where the appointment has given great pleasure.

TESTED 4-Valve Receivers of very high efficiency and make, £35, complete with loud speaker. Sydney Radio, 269 Elizabeth Street, Sydney.

**RADIO RADIO**

Wireless Dealers Only Supplied.

Our new 120 page Illustrated List of Radio Parts now ready, Showing Trade and Retail Prices. Copy sent on application. COMPLETE SETS AND COMPONENT PARTS.

We were one of the very first Wholesale Factors of Radio, and to-day hold the largest stocks of Wireless Goods in the British Empire.

Staggering Prices — Huge Stocks — Get to Know Us — It will Pay you.

Wireless Traders order from us. We have a large Export Department, and know how to deal with your Indents. To prevent delay goods can be ordered through London Merchants or if ordering direct should be accompanied by 25 per cent. deposit, balance at Sight-Draft.

Buy from an Established House.

Please Note — Wholesale Only

**HOBDAY BROS. LTD.** (Dept. T)21, 23, 25 and 27 Great Eastern Street  
LONDON, E.C.2Cables: "Yadboh," Finsquare, London.  
A.B.C. 6th Edition.

**ENORMOUS  
SUCCESS**  
**C.A.V.**



**C.A. Vandervell & Co. Ltd.**  
ACTON VALE, LONDON, W.3.

**It's EDISWAN***So It's Reliable*

"Radiophone." The mere fact that it's an "Ediswan" product is sufficient guarantee as to the quality of the workmanship and parts used.

The Radiophone surpasses many of the more expensive 4 Valve sets offered, for long-range reception and selectivity.

Let us demonstrate it to you.

**Edison Swan Electric Co. Ltd.**

58 Clarence Street, Sydney

368 Little Collins St., Melbourne 32-34 Adelaide St, Brisbane

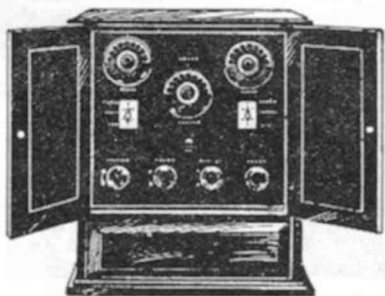

4 Valve Long Range

**RADIOPHONE**

Separate terminals are supplied for 'phones and loud speaker. A switch provides for the use of 2, 3, or 4 Valves. Aerial circuit may be earthed by means of switch, the batteries at the same time being disconnected.

Sockets for loading coils are provided to receive wave lengths over 500 metres.

Leading Dealers Stock Ediswan Equipment



# UNITED'S GUARANTEED RADIO PARTS

Your Dealer Can Supply You  
At These Prices



**"PICO" HEAD PHONES.**  
Strong, light, durable, fully guaranteed, give you the programmes at their best.



**"UNITED" HOME ASSEMBLY SETS.**  
One to four valves; can be put together with screw-driver and a pair of pliers. Prices, 5 to 11 guineas.



**"SIGNAL" AUDIO FREQUENCY TRANSFORMER.**  
Made in Australia. As good as the most expensive imported. Guaranteed 2 to 1, 3½ to 1, 5 to 1, 7½ to 1 ratio, 21/-.



**"THE MUSIC MASTER."**  
The de Luxe Loud Speaker. Has an amplifying bell of resonant wood. Price, £12.

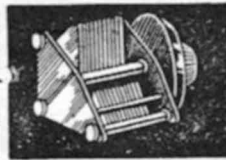

**FIBROC VARIABLE CONDENSER.**  
True insulation. Accurate, Reliable. Plain or Vernier. Cheap. . . .

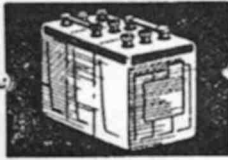

**"UNITED" BATTERIES.**  
Made by the Clyde Engineering Co., Ltd. Announcements later. . . .

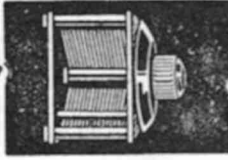

**"SIGNAL" CONDENSERS.**  
Distance and volume assured. All capacities. Plain and vernier.



**"ATLAS" LOUD SPEAKERS.**  
The "Musician of the Air." Clear, mellow, true. Price, £7/10/-.



**UNITED CRYSTALS.**  
Galena, Midite, Hertzite, Pyrites, Claritone, Zincite . . . . 1/3  
Mounted . . . . 1/9



**"UNITED" COILS.**  
Guaranteed, correct, efficient, true inductance. Prices, 2/- upwards. Mounted & unmounted.



**STATIC LIGHTNING ARRESTER.**  
Efficient. Fulfilling requirements of the Underwriters. Price, 2/6.



**QUICKHEAT GRID LEAKS.**  
13 different capacities. 10,000 to 100,000 ohms. ½ meg. to 5 meg. Accurate.



**"SIGNAL" DIALS.**  
Best grade bushings, absolutely true. Inlaid with fast white enamel.



**BRANDES TABLE TALKER.**  
Strong and distinct. As mellow in tone as an old violin. Price, £4/15/-.



**"SIGNAL" FIXED CONDENSER.**  
Grid and phone. Guaranteed. All capacities. .0001 to .004. Price 1/6



**"SIGNAL" PUSH AND PULL POWER TRANSFORMERS.**  
—for more amplification. 23/3/- the pair.



**DE LUXE COIL PANEL & COUPLING PLUGS.**  
Genuine Bakelite. True connections. Perfect fit. Easy adjustment. Price . . . . 3/6



**"ECHO" LOUD SPEAKER.**  
Strong and clear. Special shape and construction. Price, £4/15/-



**FROST PHONES.**  
2,000 ohm. Aluminium ear pieces . . . 23/6  
3,000 ohm. Aluminium ear pieces . . . 27/6  
3,200 ohm. Maroon Bakelite ear pieces, 45/-

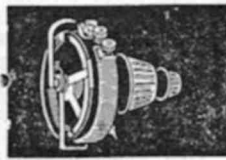

**FROST RADIO 607-610 CONTROL UNIT.**  
Combination of Rheostat and Potentiometer, called "Pot-Rheo," 17/6.

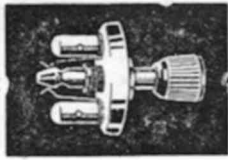

**FROST RADIO 608.**  
Fresh Pull Battery Switch. Price, 4/-.

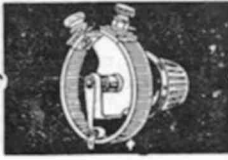

**FROST RADIO RHEOSTATS & POTENTIOMETERS.**  
Nos. 650-2, Maroon Bakelite, 6 & 35 ohm. rheostats . . . . 7/3  
Nos. 651-3. Same with vernier . . . . 9/6



**FROST RADIO No. 617-618.**  
Sponge base shock absorber sockets. Per 201A and UV199, 4/6



**"COLUMBIA" GEARED THREE COIL MOUNTING.**  
Bakelite. Mounts on 4 screws. Positive connections. Eliminates body capacity .. 36/-



**"COLUMBIA" MOULDED BAKELITE VARIOMETER.**  
Bakelite. Green silk wire. No metal bearings post in front or rear . . . . . 40/-

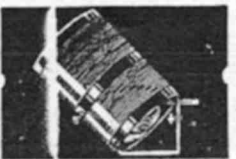

**"COLUMBIA" ALL-METER 180° COUPLER.**  
Bank wound inductance. Tapped for wave lengths up to 2,600 metres. Green silk windings. . . . . 55/-



**"PALL MALL" 180° VARIOCOUPLER.**  
Superlatively variable inductance. Genuine Bakelite. Green silk wire. Fitted with dial.



**"UNITED" TWO COIL MOUNTING.**  
Perfectly made for outside panel mounting. Good fitting plugs. Nickel plated shaft. Attractive knobs.

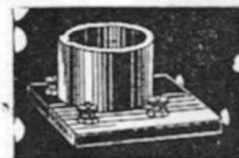

**"HOOSICK" STANDARD SOCKET.**  
No. 107 combination surface and panel mounting socket. Genuine Maroon Bakelite, barrel, 4/9. 5/-



**"FORTEVOX" CRYSTAL DETECTOR.**  
Glass enclosed, ebonite, 1 inch barrel, 4/9. Many other styles available.

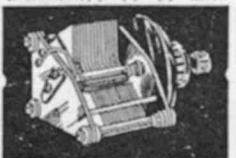

**"RELIANCE" DE LUXE LOW LOSS CONDENSER.**  
Brass or aluminium plates. Grounded end-plates. Self-centring bearings. Adjustable rotor. All capacities.



**"MUTER" FIXED CONDENSERS.**  
—with or without leaks, first quality. Tested. All capacities.

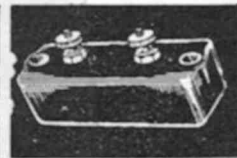

**"MUTER" LIGHTNING ARRESTER.**  
Reliable, handsomely finished in brown porcelain. Passed by the Fire Underwriters.



**BRADLEY STAT.**  
An ideal rheostat for every type of tube. Also Bradleaks, Brakelohms, Bradleyohmmeters.

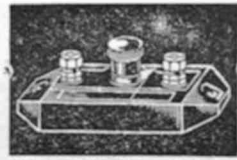

**"FRESHMAN" VARIABLE RESISTANCE LEAK & CONDENSER.**  
—for either base or panel mounting. With .0025 condenser.



**"UNITED" AMPLIFYING UNITS.**  
Two valves. Added to any set increases strength of signals. For Crystal Sets, £4/4/- Power for Valve Sets, £5/5/-.



**THE C.H. 30 OHM RADIO RHEOSTAT.**  
The scientific rheo.—for control of the amp. UV 201A-C301A type receiving tubes, & the UV199-C299 type.

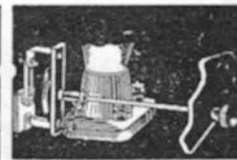

**THE C.H. VARIABLE GRID LEAK.**  
A Cutter-Hammer precision instrument. Mount valve on the grid post. Maximum efficiency. No "body" noises.

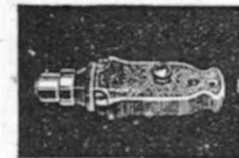

**"FRESHMAN" ANTENNELLA.**  
Eliminates static. Fits any electric light socket. No aerial needed.



**"FORTEVOX" SWITCHES.**  
Double throw. Double and single pole switches. Nickel plated. Mounted on ebonite. Suitable for use on panels or separate.



**DE LUXE LOW LOSS COIL PLUG.**  
Genuine moulded Bakelite. Perfect fit. Special spring sheath contacts.

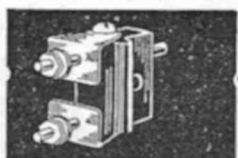

**DE LUXE LOW LOSS COUPLING PLUG.**  
Genuine Bakelite. Low dielectric loss. No contact trouble. Swivel ends, do not unscrew.



**DE LUXE LOW LOSS PANEL PLUG.**  
Genuine moulded Bakelite. Highly polished. Perfectly fitting contact points with special spring sheaths.



**PORCELAIN INSULATORS.**  
Barrel type, medium size, well glazed surface, providing splendid insulation. Very strong.



**INSULATED METAL LEAD-IN STRIP.**  
Well insulated, very thin, bends to shape of window. No boring necessary.

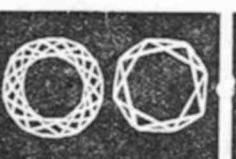

**DE LUXE LOW LOSS COIL.**  
Minimum Self-capacity. Maximum Inductance. Minimum Resistance. Maximum Air-spacing.



**TERMINALS AND BINDING POSTS.**  
Metal insulated. All sizes and all styles.



**PORCELAIN INSULATORS.**  
Small "Egg" type. Perfectly glazed. Uniformly smooth. Very strong.

**UNITED DISTRIBUTORS LIMITED**

WHOLESALE ONLY

72 CLARENCE ST., SYDNEY.

592 BOURKE ST., MELBOURNE.

27 CHESSER ST., ADELAIDE.

847 HAY ST., PERTH.

Cr. JERVOIS QUAY & HARRIS ST., Wellington.

## SAVE EXPENSE WITH A PAIR OF PLIERS

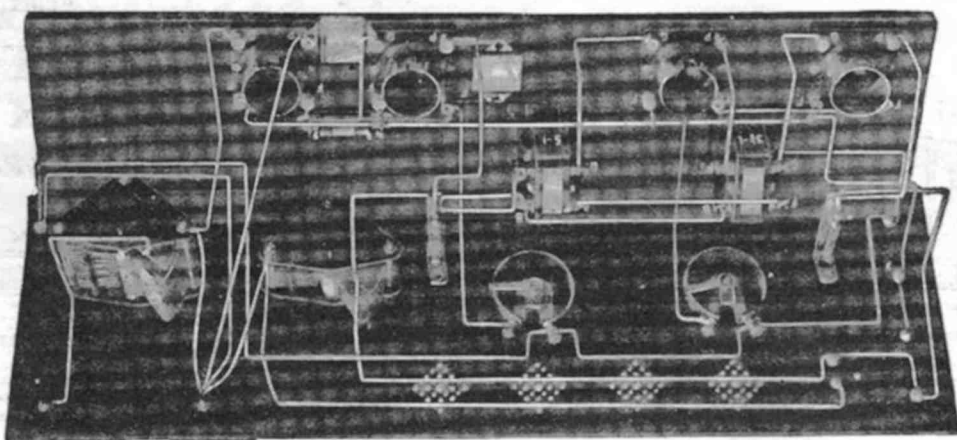

Three (Model "S") and Four (Model "T") Valve—One Stage Radio Circuit.

*A Stupendous First Appearance!*

# UMAKIT United Radio Sets

Having been the first in Australia to introduce Radio Sets which could be assembled at home, United Distributors Limited have been continually experimenting to improve them. The result of their investigations is now made patent in "Umakit" Sets.

These are not the cheapest sets available, but they are the cheapest sets in which every detail is of first quality—reliable, durable, perfect. They can be put together at home, with a pair of pliers. The circuit diagram and photographs of the front and interior which accompany each set leave no need for guesswork or experiment. They are so simple that a child can follow them.

### THE "UMAKIT" "UNIDYNE" CIRCUIT

as used in Model S and T utilises the Neurodyne principle to apply to waves from 60 to 2000 metres in length.

This means pure tone, full volume, and freedom from "howling" or distortion. No damping resistances, no potentiometer to curtail the life of the valves.

### "UMAKIT" SETS.

Ready to assemble, complete, except valves, batteries, and phones.

	Fixed Retail Price.
Model P: The "Simple" One Valve (199 Socket) . . . . .	£5/5/-
Model Q: The "Selective" Two Valve (199 Socket) . . . . .	9/9/-
Model R: The "Selective" Three Valve (Two Audio) . . . . .	10/10/-

Standard equipment R to W Model is for 201A Valve.

	Fixed Retail Price.
Model S: The "Unidyne" Three Valve (One Radio, Two Audio) . . . . .	10/10/-
Model T: The "Unidyne" Four Valve (One Radio, Two Audio) . . . . .	11/11/-
Power Amplifying Units . . . . .	5/5/-

Other sockets can be supplied.

*See this interesting new line at your Radio Dealers!*

# United Distributors Limited

72 CLARENCE STREET,  
SYDNEY.

(Wholesale Only)

592 BOURKE STREET,  
MELBOURNE.

And at Adelaide, Perth, Brisbane, Hobart, Wellington.

SAVE EXPENSE WITH A PAIR OF PLIERS

# CLIX

TRADE MARK

The Electro Link  
with 159 Uses.

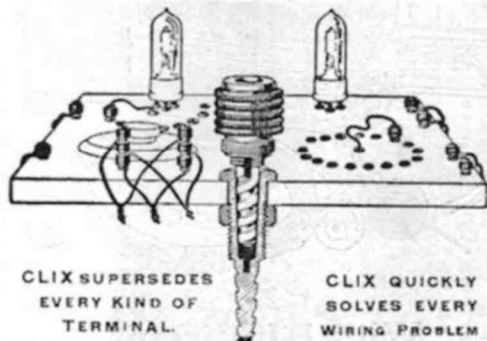

CLIX SUPERSEDES  
EVERY KIND OF  
TERMINAL.

CLIX QUICKLY  
SOLVES EVERY  
WIRING PROBLEM

CLIX Combination Plug-Socket is the most ingenious and efficient contact ever invented.

CLIX phenomenal and world-wide sales are convincing proof of their popularity and merit.

CLIX Illustrated Leaflet describes many applications

CLIX are patented all over the world;

Write for list to-day—Few Agencies still available.

## AUTOVEYORS LTD.

RADIO ENGINEERS, CONTRACTORS & EXPORTERS

82-84 VICTORIA-ST., WESTMINSTER, LONDON

Telegrams: Autover,  
Sowest, London.

Trade Terms on  
Application

# The WIRELESS EXPORT TRADER

Indispensable to *TRADERS*  
throughout the World.

It is designed to assist Overseas Traders who wish to purchase in the British Wireless Markets, showing them how, when, and where they may buy most economically. Authentic reports are given of tests made on new British Sets and Components, and information on a wide range of subjects of the utmost importance to the trader are a feature of the Editorial columns.

The advertisement pages of "THE WIRELESS EXPORT TRADER" form an invaluable buyers' reference guide to British Wireless Productions.

Let us send you

**A FREE SPECIMEN COPY**

Forward your trade name and address to

THE WATERGATE PRESS LTD.,  
19 Surrey Street, Strand, London, W.C.2, England.

Publishers also of "THE WIRELESS TRADER"—  
the Trade Journal of the British Wireless Industry.

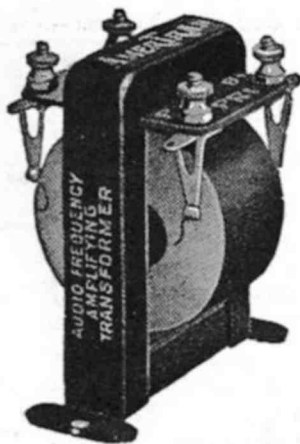

"IMPROVE YOUR SET  
WITH AN AMERTRAN"

You are sure of the best results  
only by using the best  
Transformer

## "AMERTRAN"

Squeals and howls in audio transformers are due to regeneration between the tubes and the amplifiers. To get rid of this trouble, very careful wiring is necessary. The grid and plate leads must be short and straight, and the other wires of the set must be grouped together. Insulated wires should be used, if possible. A proper "C" battery should be used in the grid circuit of each tube to match the first battery used in accordance with directions given with the transformer. Also, squeals may be avoided by placing a resistance of  $\frac{1}{2}$  megohm across the secondary of the last transformer. Capacity should not be placed across the secondary, but may be placed across the primary. This capacity may be as high as .004 M.M.F.

Australian Distributors:

WELBY RADIO CO.

13 ROYAL ARCADE, SYDNEY



# PROCRASTINATION

*IS THE THIEF OF TIME !*

**W**HEN you keep putting a thing off, somehow it never seems to get done.

How often have you missed a copy of "Wireless Weekly" just because you forgot to call at the bookstall before they were sold out?

"Wireless Weekly" keeps you in touch with everything wireless.

Its columns of reading matter gives you information you can get from no other paper. Its advertisement columns keep you informed of all the latest apparatus arriving on the market.

Let it keep you up to date. Get it regularly by mail.

## "SUBSCRIPTION FORM."

To the Editor,  
"Wireless Weekly,"  
12/16 Regent St., Sydney.

Please forward me for.....  
months "Wireless Weekly," for which I  
enclose.....plus exchange of  
country cheque.

.....192.....

Signed.....

Address.....

Annual Subscription, 13/-, post free.

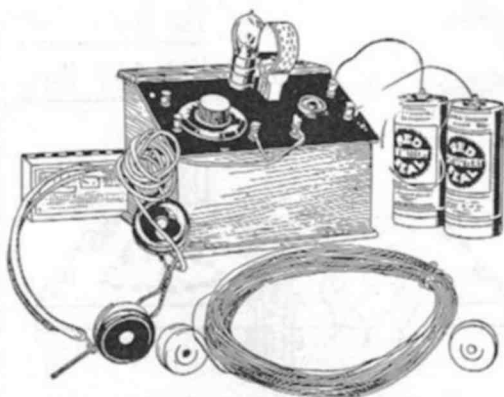

With P.I. Circuit

**"COMET"**

**One Valve Set**

**£8/10/-**

Great public interest will centre in Radio this coming Winter, and for successful reception the best sets and parts are necessary.

David Jones' now offer the famous "Comet" One Valve Set with P.I. Circuit and complete with Phillips Dry Cell Valve, all batteries, coils, phones and full aerial equipment. The range of this set is 150 miles. Price, complete ..... £8/10/-

As above with one stage audio frequency. Complete for ..... £12/12/-  
Range approximately, 250 miles.

**DAVID JONES'**

*For Radio Service*

**22 York-street, Sydney**

## 'Tis Quality Radio that Counts

CALL AND HEAR OUR SETS AND LISTEN TO THE  
CLEAR RECEPTION.

PRICES RANGE from £8 for a 1 valve set to £75 for a  
5 valve set.

B Batteries.

WINCHESTER.

22½ V., large capacity cells . . . . . 13/-  
45 V., large capacity cells . . . . . 26/-

### New Gramophone - Radio Combination

Its tone will satisfy the musician and its appearance will  
beautify the home.

MAKES ENTERTAINMENT AT HOME EASY

Terms Arranged if Required

ENQUIRIES INVITED FROM COUNTRY CUSTOMERS.

Write for our New Radio Catalogue  
which gives circuits and Prices for all component parts.

# Mack Simmons Ltd.

Remember our Motto—Quality Consistent with Reasonable Prices

Headquarters: HAYMARKET, SYDNEY  
THE WORLD'S GREATEST SPORTS STORE

## Q.S.L.

The meaning of the three letters QSL is: "Please give me a receipt" — or, in other words—"Send me an acknowledgement."

There isn't a transmitter on the air now who is not glad to get a report on his signals, whether they are phone or C.W.

You can put everything you want to say on a Publicity Press QSL card. It takes only a minute to fill in and conveys all the information the transmitter wants.

Over the last few months we have printed thousands of these cards for both transmitters and receivers, among them 2UW, 2CX, 2BF, 2LM, 2WW, 4CK, etc.

There is a QSL card for every purpose and they may be had either from stock or to suit individual tastes.

Write, phone or call.

Publicity Press Ltd.

Printers and  
Publishers.

12-16 Regent Street  
SYDNEY

Phones Red. 964 & 930.

# COL-MO

## READY TO WIRE SETS

### Genuine Radio Sets that will work

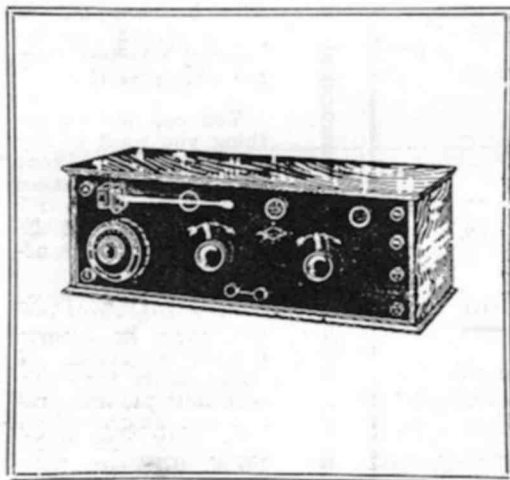

Our Ready-to-Wire Sets are complete with wiring diagrams.

No previous experience necessary to wire a COL-MO Ready-to-Wire Set.

**Wiring takes Time and Time is Money**  
**DO THE JOB YOURSELF AND SAVE MONEY**

**ONE VALVE SET:**  
 Complete with Cabinet  
 £2/15/0

**TWO-VALVE SET:**  
 Complete with Cabinet  
 £4/10/0

**THREE-VALVE SET:**  
 Complete with Cabinet  
 £6/5/0

**COLVILLE-MOORE**  
**WIRELESS SUPPLIES, LIMITED.**  
 10 ROWE STREET (NEAR HOTEL AUSTRALIA) SYDNEY

*See our Exhibit at the Hordern Pavilion, Royal Agricultural Show.*

## COL-MO LITTLE GIANT SETS

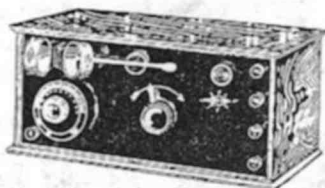

The Little Giant Sets are sold complete with all accessories, including aerial wire. The three valve Little Giant is complete with all accessories and Loud Speaker.

One Valve Set . . . . .	£7/10/-
Two Valve Set . . . . .	£12/10/-
Three Valve Set . . . . .	£24

THE LITTLE GIANT ALWAYS LIVES UP TO ITS NAME. A GIANT IN TONAL QUALITIES, EFFICIENCY AND SIMPLICITY OF OPERATION ARE FEATURES NOT SURPASSED IN LARGER HIGHER-PRICED INSTRUMENTS.

## Col-Mo Low Loss Condensers

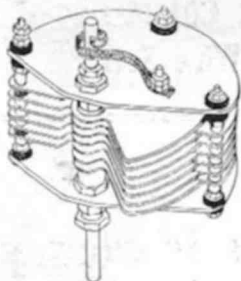

It is interesting to note that at last a GROUNDED ROTOR brass plate condenser of the LOW LOSS type has been constructed in Sydney. The construction is entirely of brass, having brass ends common to the Rotary plates, and electrically connected thereto by a pig-tail connection of brass flex. Absolutely no body capacity effects are possible with this condenser for in addition to the earthed end plates, the fixed plates are further screened by two extra Rotary plates. Designed on a straight line principle to facilitate accurate tuning.

*COLMO LOW LOSS CONDENSERS, capacity only .00025*

**16/- and 22/6**

**Colville - Moore**  
**Wireless Supplies, Limited**  
 10 Rowe Street (Opposite Hotel Australia) Sydney



# PHILMORE

## RADIO APPARATUS

	Dealers.	Retail.
Contact Points, with Hex Nuts, unassembled .. per doz.		6d.
Switch Stops, with Hex Nuts, unassembled .. .. "		6d.
Binding Posts, Nickel-plated, unassembled .. .. "		2/-
Insulated Knob Binding Posts, assembled .. .. "		3/9
Initialled Binding Posts (8 on a card) .. .. "		3/-
Brass Hexagon Nuts, 6/32 .. .. "		3d.
Sliders, Brass, $\frac{1}{4}$ in. .. .. "		1/-
Antenna Insulators .. .. "		1/-
Switch Levers .. .. "		1/3
Inductance Switch .. .. "		5/6
Insulated Dials, 2in. .. .. "		1/9
Insulated Dials, 3in. .. .. "		2/-
V. T. Sockets, moulded .. .. "		2/6
V. T. Sockets, metal shell .. .. "		3/-
U.V. 199 Sockets .. .. "		2/9
Rheostats, mounted base, 6 ohm .. .. "		3/-
Rheostats, mounted base, 30 ohm .. .. "	2/8	4/-
Potentiometer, mounted base, 240 ohm .. .. "	3/2	4/9
Potentiometer, mounted base, 400 ohm .. .. "	3/4	5/-
Glass Enclosed Detector, unassembled .. .. "		3/-
Crystal Detector, Open Type, unmounted .. .. "		1/3

FROM ALL DEALERS.

## PACIFIC ELECTRIC CO. LTD.

87 CLARENCE STREET, SYDNEY

Phone B 5891

Sole Australian Distributors

Reasons why you will be  
satisfied with the

# AWA Transformer

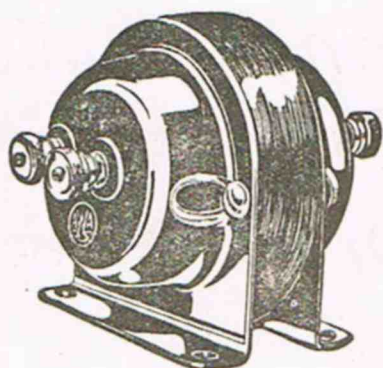

It's an



Product

In the construction of an all-Australian-made low-frequency transformer, Amalgamated Wireless have spared no effort to produce a thoroughly efficient instrument.

Each AWA Transformer is subject to a 1000 volts insulation test between windings and casing, and between the windings themselves; any one not giving infinity reading is rejected. Low self-capacity and the special arrangement of primary and secondary coils, gives uniform amplification over the whole band of useful frequencies.

It is an ideal Transformer for low loss work.

Automatic-machine wound, the windings are standard; inductance values are measured on individual transformers, and each one is tested against standard for signal strength. Both windings are covered by an insulating, non-hygroscopic varnish, giving absolute protection against atmospheric humidity. A comparatively heavily-gauge wire is used to minimise the possibility of break-down, and there are a sufficient number of turns to bring the natural frequency of the windings above the audibility range, preventing "blasting."

Made in two standard ratios—5-1 and  $3\frac{1}{2}$ -1. Price, with polished black finish .. .. 30/-

Also supplied with a polished nickel finish. Price .. .. 32/-

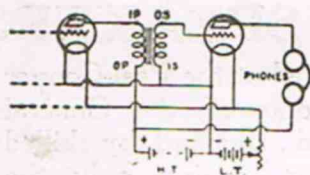

Showing arrangement of A.W.A. Transformer in one stage low frequency circuit.

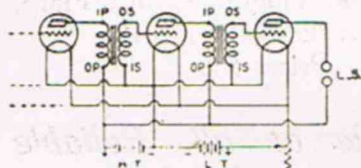

Showing A.W.A. Transformer in two stage low frequency circuit.

Made in Australia by

Amalgamated  Wireless  
(Australasia) Ltd.



# *The Musical Instrument of Wireless!*

THE GECOPHONE loud speaker was created with a true regard for the laws of tone-production—established before wireless was a reality. It gives perfectly even and distortionless reproduction over the whole range of voice and instrument notes.

The moulded ebonite horn with 15in. flare is correctly designed to give the full mellow tone of the original voice or music. Four terminals are provided on the base of the instrument to allow a variation of the impedance to suit the types of valves being used in the set.

## GECOPHONE

### LOUD SPEAKERS

are manufactured at the Peel-Conner Telephone Works of the General Electric Co. Ltd., England, by skilled British workmen, using only the finest materials.

Specifications: Height, 26in.; Flare, 15in.; Ebonite Horn.

Price, £9.

A GECOPHONE loud speaker will give you the fullest enjoyment from wireless broadcasted programmes. Hear one today.

*Obtainable at all Reliable  
Wireless Dealers*

## British General Electric Co. Ltd.

154 CLARENCE STREET, SYDNEY, and at  
MELBOURNE, ADELAIDE, PERTH, NEWCASTLE

**GECOPHONE SUPREME WIRELESS APPARATUS**