

# RADIO

IN AUSTRALIA  
& NEW ZEALAND

Registered at G.P.O., Sydney, for transmission by post as a newspaper.

VOL. II

DECEMBER 10, 1924

No. 45



FULL CONSTRUCTIONAL DETAILS WITHIN.

# All Sizes and Grades of C.M.A. Wires and Cables carried in stock



ALSO  
**BARE COPPER**  
WIRES  
CABLES  
BARS  
RODS  
STRIPS



**Instrument Wires**  
Double Cotton Covered  
Single Cotton Covered  
Double Silk Covered  
Single Silk Covered  
  
Enamelled Copper  
Wires.



BRITISH INSULATED & HELSBY CABLES, LTD., ENGLAND.

AGENTS:

## William Adams & Co. Limited

175 Clarence Street, SYDNEY.

53 King Street, NEWCASTLE.

Edward and Mary Streets, BRISBANE.

# RADIO

IN AUSTRALIA  
& NEW ZEALAND.  
*Incorporating "Sea, Land and Air".*

## CONTENTS

Copyright Registered.

Volume II.                      DECEMBER 10, 1924                      Number 45

	Page.
Radiatorial—	
Commercial Radio Achievement .. . . .	555
An Efficient Long-distance Receiver .. . . .	556
Wireless Developments .. . . .	558
Receiver Noises .. . . .	560
A 60-600 Meter Tuner .. . . .	564
Four First-rate Circuits .. . . .	568
Modern Ship's Wireless .. . . .	570
Radio Department Enlarged .. . . .	570
Broadcasting and Listening-in .. . . .	572
Two-way Communication with England and America	574
Australian Radio Engineers' Fine Feat .. . . .	578
Calls Heard .. . . .	580
How to Make an Audibility Meter .. . . .	582
Aerial Location and the Material to Use .. . . .	585
What Happens Inside Your Battery .. . . .	586
Our London Letter .. . . .	588
Club Notes and News .. . . .	589
A Loose-coupled Short Wave Set .. . . .	590
"Mike" .. . . .	592
Keeping Your Sets Spick and Span .. . . .	594
An Explanation of Radio Circuits .. . . .	595
Queries Answered .. . . .	596
Movements of Marine Wireless Officers .. . . .	599

Published by

### THE WIRELESS PRESS

Gloucester House,                      97 CLARENCE ST.,                      Australasia Chambers,  
44 Market Street, Melbourne.                      SYDNEY.                      Wellington, N.Z.

PRICE, 6d. per Copy.

Subscription Rate: 10/- per annum (26 issues) throughout Australia and New Zealand; Foreign Rate, 12/6 (26 issues).

Obtainable from all Booksellers and News Agents, also the N.S.W. Bookstall Co., Ltd.—all branches.

Canada and U.S.A.:  
The Wireless Press Inc.,  
326 Broadway,  
New York City.

Wholesale Distributing Agents:  
GORDON & GOTCH (AUSTRALASIA), LTD.,  
Sydney, Melbourne, Adelaide, Brisbane, Launceston, Perth,  
Auckland, Wellington, Christchurch, and Dunedin, N.Z.

Great Britain:  
The Wireless Press Ltd.,  
12-13 Henrietta St.,  
London, W.C.2

By Jove, It's Wonderful  
WITH  
"PICO" Head-phones!

You hear the programmes at their best if you use "PICO" Head-phones—clearly, faithfully, in their full volume—just as if the artists were in the room with you.

"PICO" Head-phones are light, cool and comfortable on the head—Ideal for Summer. They are just as strong as they are sensitive, and will give practically endless wear.

FULLY GUARANTEED,  
Price - - - 25/-  
AT ALL RADIO STORES.

Ask your Dealer to show you

**SIGNAL Home Assembly Sets**

The Cheapest way to have a perfect Valve Set.

What is the Best Xmas Gift? A Radio Set or Radio Parts!

**UNITED DISTRIBUTORS, LTD.,**

(Wholesale only).

72 CLARENCE ST., SYDNEY.

592 BOURKE ST., MELBOURNE.

And at Adelaide, Perth, Brisbane, Hobart and Wellington.



**Compare it with Expensive Imported Transformers**

This is the Signal Audio Frequency Transformer, made in Australia expressly for United Distributors, Ltd.

It is fully equal to any available, yet, being Australian-made, 60% import charges are saved. That is why



**SIGNAL Audio Frequency  
TRANSFORMERS**

Cost  
only **£1/1/-**

AT ALL RADIO STORES.

Five to 1 or 3½ to 1 ratio. Magnetically shielded in a shell of original design and perfect finish. They ensure loud, clear tone, free from howl or distortion.

**United Distributors Limited**

(Wholesale only),

72 Clarence Street,  
Sydney.

592 Bourke Street,  
Melbourne.

And at Brisbane, Perth, Adelaide, Hobart and Wellington.



## Commercial Radio Achievement



THE achievements in wireless during the last few weeks have not only been remarkable, but they follow so closely one upon another as to dazzle the imagination of the most experienced experimenter. Feats that a few years ago would have been regarded as revolutionary have during this time become commonplace.

TOO much credit cannot be given to those workers in Australia, New Zealand and England who have been instrumental in achieving such success in the field of low-power short wave telephony.

the amateur and experimenter cannot achieve any considerable measure of success without reliance upon the work of these men.

IN 1898 Sir Oliver Lodge in his patent for syntonic wireless telegraphy, obtained more prolonged oscillations and better selectivity. This was followed a few years later by Marconi's invention of coupled circuits, enabling more energy to be transmitted and greater selectivity still to be obtained. In 1913, Messier produced continuous oscillations by re-action, thus bringing into existence the regenerative circuit, used by practi-

The Christmas issue of RADIO will contain, among other leading features, full constructional details for building several Crystal-valve circuits. These receivers will embrace something novel in the way of switch control.

RADIO will be on Sale everywhere on or about December 18. Order your copy now!

ONE cannot contemplate the results achieved, however, without remembering the great work of and the debt that is due by the experimenters of to-day to the research workers and inventors who have so truly laid the foundations on which the advancing science of wireless is to-day building. Maxwell's mathematical calculations as to the existence of ether waves; Hertz's demonstration of their propagation, and Marconi's application of the laboratory work of these scientists to practical wireless telegraphy were probably the most brilliant efforts of the second half of the last century.

OTHER inventors and research engineers in connection with commercial wireless who have built the foundations on which we to-day rely are too numerous to mention, yet a few principal ones will serve to show that

cally every experimenter to-day. Franklin, a research engineer of the Marconi company, utilised the same principle for the elimination of losses with receiving circuits.

WITH valves it should be known that all the inventors and inventions that have to do with the development of the thermionic valve have been linked with commercial radio interests. Dr. J. A. Fleming developed the so-called Edison effect in 1904, while, as is well-known, the third electrode or grid was the work of Dr. Le de Forrest in 1907. In 1914, Langmuir, of the research staff of the General Electric Company of America produced hard thermionic valves and thus eliminated ironisation.

IT can thus be seen even from these few names what the world owes to its commercial wireless interests.

**DEAR READER! WHEN YOU HAVE FINISHED WITH THIS COPY OF "RADIO" LEND IT TO A FRIEND — DON'T KEEP A GOOD THING TO YOURSELF!**



This radio frequency plate current flows through the re-action coil and induces a radio frequency voltage in the grid or aerial coil, to which it is coupled. If these coils have the correct relative polarity, the voltages induced in the grid coil will re-enforce the radio oscillations in the grid circuit. This re-enforced oscillation is then amplified by the valves, increasing the radio frequency current through the re-action coil, and further increasing and re-enforcing the oscillation in the grid circuit of the first valve. Thus the regenerative circuit effect of the reaction coil is cumulative, and by carefully adjusting the

METRES.	L1.	L2.	L3.
100-250	25	35	35
250-350	35	35	50
300-500	50	50	75
600-1000	100	75	100
1000-1500	150	100	200
1500-2500	200	150	250

- 1 Grid Leak, 2 megohms.
- 2 Filament Resistances
- Honeycomb Coils
- Coil Mountings
- 2 Valves
- 2 Valve Holders.

The above range of coils will cover a number of amateur and all Australian broadcasting wave-lengths. The rheostats R1 and R2 will vary according to the type of valve in use.

Valves of the dull-emitter type taking only .06 amps would require a rheostat of 30 ohms resistance, whereas the valve that usually takes .6

**A PLEASANT AND INTERESTING EVENING.**

BY invitation of the Western Electric Company (Australia) Ltd., *Radio* was present at an enjoyable social evening at the Royal Society's Rooms, Sydney, last month, when two special films entitled, "The Audion"

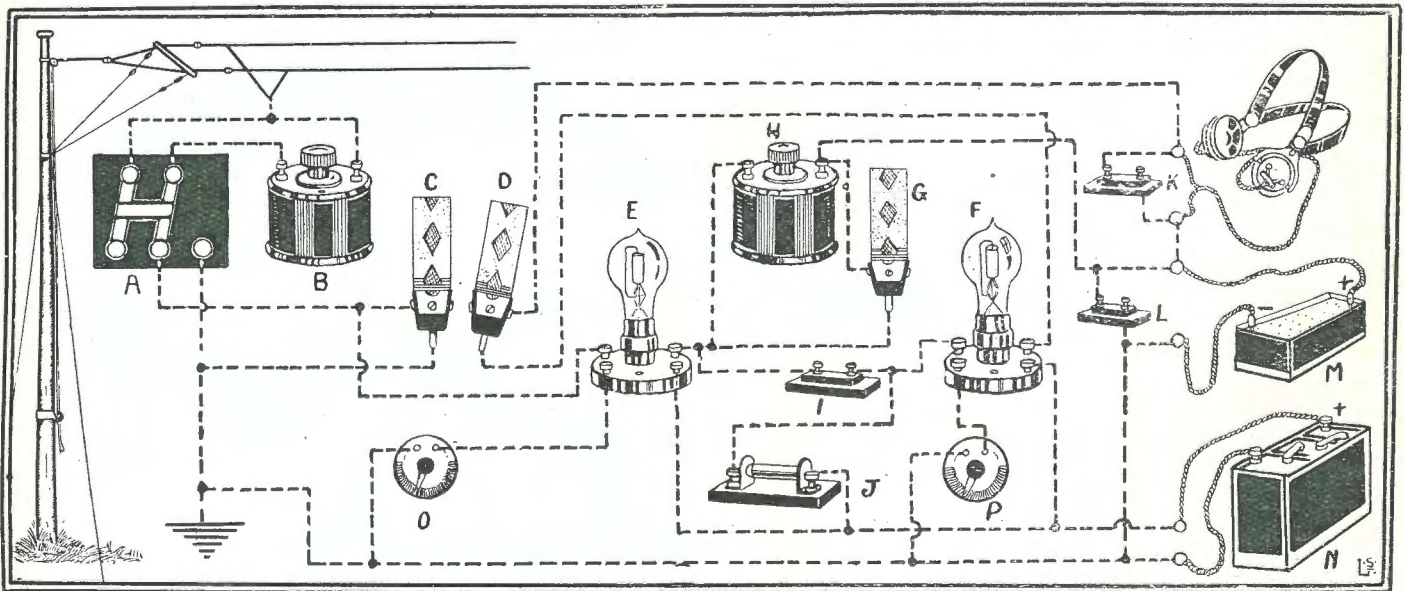

Fig. 2.—Showing wiring connections of the two-valve receiver: A being Series-Parallel Switch; B, Aerial Tuning Condenser; C, Aerial Coil; D, Re-action Coil; E, Radio Frequency Amplification Valve; F, Detector Valve; G, Anode Coil; H, Anode Condenser; I, Grid Condenser; J, Grid Leak; K, Phone Condenser; L, Bi-pass Condenser; M, High Tension Battery; N, Low Tension Battery; O and P, Filament Rheostats.

coupling between the grid and re-action coils, the oscillation may be built up to a strength many times greater than would be the case if the regenerative circuit were not employed.

Any circuit that gives regeneration is called a feed-back circuit, owing to the fact that oscillation energy is fed back from the plate circuit to the grid circuit.

When adjusting the re-action coil, vary the coupling until the silent point is reached. Extreme range is obtained by this method.

The coils necessary for various wave-lengths are as follows:—

amps would require a rheostat of only 10 ohms. The grid leak has a resistance of two megohms.

No difficulty should be experienced in the building and operation of this receiver and it will give good results over long distances when used in conjunction with head telephones, but for loud-speaker operation, audio frequency amplification must be added.

The parts necessary to build this receiver are as follows:—

- 1 Variable Condenser, .001 mfd.
- 1 Variable Condenser, .0003 mfd.
- 1 Fixed Condenser, .02 mfd.
- 1 Fixed Condenser, .0003 mfd.
- 1 Fixed Condenser, 1 mfd.

and "Telephone Inventors of Today" were screened.

A large number of employees of the Western Electric Company, the wireless and telephone trade and others were present and the evening was voted a pronounced success.

It is hoped that it will not be long before the company repeats this novel innovation.

If concerts come in well at first and then die out and do not come back, your batteries are weak.

# Wireless Developments

THE article we publish below has been taken from the columns of the London "Daily Telegraph," but it is interesting to note that with the alteration of a few names the conditions described and the forecasts made—which are already coming into fulfilment—might easily have been those of Australian broadcasting and wireless generally. Where circumstances do not yet coincide, it would be as well to remember that what is happening in English wireless to-day will, in all probability, come about in Australia to-morrow.



LOOKING back over the history of scientific developments, it is impossible to find a parallel for the rapid and immense increase in popularity which has followed wireless developments. At one moment it was the recondite and obscure hobby of a few enthusiastic experimentalists, who, with the true fire of the amateur, would stay up half the night to catch a few almost meaningless dots and dashes flashed from one of a small number of near-by stations. Next moment, as it seemed, tens of thousands of people had realised the vast potentialities of the new science.

Needless to say, the greatest impulse of all was given by the inauguration of properly-equipped transmission stations, whose messages are not confined to "Morse code" and snatches of speech, but with music, with lectures, and even with dramatic plays which now offer an unending source of entertainment. It must be conceded that the British Broadcasting Company, whose function it is during most hours of the day to provide something to which any inhabitant of the British Isles can listen with pleasure, has done its work exceedingly well, and to-day there are very few districts in the British Isles to which its programme cannot be made to penetrate by means of a receiving set, neither costly to buy, expensive to keep up, nor difficult to handle.

We must bear in mind that, in spite of the enormous strides which broadcasting has already made, the whole proposition is still in its very early stages. Just as the motorists of the present day find it hard to believe that those who pioneered automobilism in the late 'nineties could regard the crude contraptions upon which they rode as all that was best and most up-to-date, so the listener of the

near future will wonder how we could have ever regarded the past year as one characterised by great wireless advancement. Yet there can be no doubt that these last twelve months have witnessed developments of great and far-reaching importance.

## PURITY OF REPRODUCTION.

Clearly the quality which is of overwhelming importance in the future spread of wireless is purity of reproduction. There are, of course, a large number of interested amateurs, to whom the technique of radio science is a perennial delight, and whose object is ever to search out and collect distant and more distant stations. It will be admitted at once that this reaching out into the ether has a fascination all of its own, but for every one who is prepared to dedicate his receiving set to such a purpose, there are a score who want in their own homes to enjoy, under conditions of purity and clarity of production, the concerts of the local broadcasting station. Accordingly, the most important improvements in the generality of well-made wireless sets is an enhanced musical capability, combined with an increased simplicity in control. In many sets which in the past have given disappointment, the attempt has been made by the enterprising designer to obtain, as it were, too high an efficiency. In producing a circuit and an arrangement of component parts that attain to the necessary standard of sensibility, he has, unfortunately, though unavoidably, introduced a serious disadvantage in this, that such a set is inherently difficult to control. Everyone is familiar with the outcry that periodically arises about the unwelcome squeaks and howls which are hurled into the ether because so many sets are kept in a state of violent oscillation. There can be little doubt that

this "radio crime," unforgivable though it may be at the moment of its commission, springs from innocence and ignorance rather than from any other cause, and it is, in fact, due very largely to many sets being so contrived that only the expert can properly handle them. This state of affairs has been seriously holding back wireless progress from a domestic point of view, and one is glad to know that serious efforts have been made to remedy it.

Another thing that has been realised by the larger firms that form the backbone of what is ultimately to be a very good industry indeed, is that at the present time it is unwise and, indeed, almost impossible to guarantee results. The set which somewhere in the wilds of Scotland will reproduce French transmissions with remarkable loudness on two valves, may refuse to bring in the nearest broadcasting station at more than a whisper when it is operated in some other part of the country. Much research will have to be done before it is possible to lay down hard and fast rules for the performance of any given receiver. Meanwhile, the bigger manufacturers have wisely adopted a conservative policy. Their products will very frequently exceed all that is promised for them, but even in the least favourable conditions they can be relied upon to work as well as the user has a right to expect. At last year's exhibition a very notable feature was the then recent introduction of the dull emitter valve, the use of which eliminated the need for installing accumulators with all their attendant objections of acid messiness, and the necessity for periodic recharging. During the past twelve months an immense amount of experimental work has been done upon valves of very low current consumption, and such admirable results have



been obtained that they are now standardised in nearly all the receivers of leading makes. For certain purposes the bright emitter valve is still regarded as superior, and in most cases it is initially cheaper to buy, but it requires no hardihood to prophesy that it will soon disappear from the majority of sets designed for home entertainment. The convenience of dry batteries, which are unspillable, which demand no recharging, and which, at the end of a long life, can be inexpensively replaced, is irresistible. It is now possible, by means of these dry batteries, which can be included in a self-contained cabinet, to operate large multi-valve sets with excellent results.

#### FRAME AERIALS.

With regard to the question of rendering wireless sets even more self-contained than they have been in the past, it may be said that much remains to be done in connection with frame aerials. In many cases the erection of an outdoor aerial is inconvenient and objectionable, and, indeed, there are many thousands of potential wireless users who have no facilities for large aerials. In America frame aerials are used already to a far greater extent than in Great Britain. Not only do they take up a minimum of room, enabling also the set to be transported from place to place very conveniently, but they also promote, when properly applied, that selectivity which is very much appreciated by the ordinary wireless user. This is because they have a directional quality. Many people living close to a broadcasting station wish to hear the programme of other stations uninterruptedly, in spite of the local transmission. In the majority of cases, especially in London, it is not easy to do this, even when special rejector circuits are employed. These latter, in most cases, tend to impair signal strength somewhat seriously, so that although they cut out the local station, they do not permit the more distant one to be brought up with sufficient volume. From the receiving point of view the frame aerial is undoubtedly less effective than the plain outdoor wire, but if the set itself be increased in efficiency this disturbance largely vanishes. One is glad to see that some of the firms are now producing receivers (though naturally these are of the more expensive

pattern), in which everything necessary is contained within a simple cabinet; there are no external batteries nor is any aerial or earth lead required. The frame aerial has undoubtedly enormous potentialities, but it would seem that these as yet

well realised, and it is significant that whilst a certain number of firms have adopted a programme in which cheapness is predominant, those bearing more important and recognised names have with one accord gone in for an improvement in technique, which is



Miss Victoria Merritt, with her miniature receiving set, puts her luncheon period to good use by listening-in on a concert. Very soon the girls will discard the handbag for the radio 'phone set—they will when they find out how much fun and entertainment the radio 'phone can supply.

have not yet been realised to the extent that they ought to be.

The growing necessity for components such as are demanded by amateur constructors to be made to a higher standard of accuracy has been

well worth while, even though it may imply a slightly higher initial cost.

IF you use rope as guys for your aerial, they should be slacked off during rainy weather.

# Receiver Noises

## How to Diagnose and Cure Them

By H. A. DE DASSEL.



EVERY radio enthusiast, beginner and seasoned experimenter alike, will agree that there is nothing more exasperating than to have one's otherwise perfect reception of a broadcast programme marred by foreign noises in the receiver.

Who has not experienced this at some time or other?

Sometimes the disturbance takes the form of a shrill, whistling noise, sometimes a lower howling note, or perhaps there is a rustling sound which partly obliterates the received

### GRATING NOISES.

Of course no one expects a receiver to work well if there are any intermittent connections in the wiring. Loose connections will cause rattling, grating noises in the headphones, and the obvious remedy for this is to go carefully over the wiring, tightening up all connections to binding posts, batteries, telephones, etc.

Make sure that the aerial and downlead are secured in such a way that they cannot come into contact with trees, buildings, or other ob-

If the cause of the noise cannot be readily traced to a loose connection, it is advisable to disconnect the aerial and earth from their respective terminals. If the noise disappears entirely, it is evidently not due to any defect in the receiver but to atmospheric disturbances.

### "ATMOSPHERICS."

Under ordinary circumstances "atmospherics" should not seriously mutilate broadcast reception, and while certain steps may be taken to reduce interference from this source it is not proposed to go into details here. It is worth noting, however, that inductively coupled tuning circuits afford more selective tuning and greater freedom from atmospherics than the direct coupled method.

If with aerial and earth disconnected the receiver is still noisy, the trouble may be traced to condensers, batteries, grid leaks, or transformers.

### CONDENSERS.

The moving plates in variable condensers should clear the fixed plates at all adjustments, otherwise you will have noise as well as intermittent signals, while tuning your set. Where a variable condenser is employed in a circuit having an earth connection, it is preferable that the rotating plates be connected, if possible, in the earth lead. This is a valuable aid to smooth operation.

### BATTERIES.

When old age starts to creep on dry-cell "A" or "B" batteries, some of the cells will probably disintegrate, and the chemical action which goes on will be accompanied by grating noises in the receivers. The batteries should be tested on load, with a voltmeter. That is to say, that the voltmeter readings should be taken while the batteries are actually in use in the receiver, with filaments lighted. If they show signs of petering out, they should be replaced by new ones. Radio

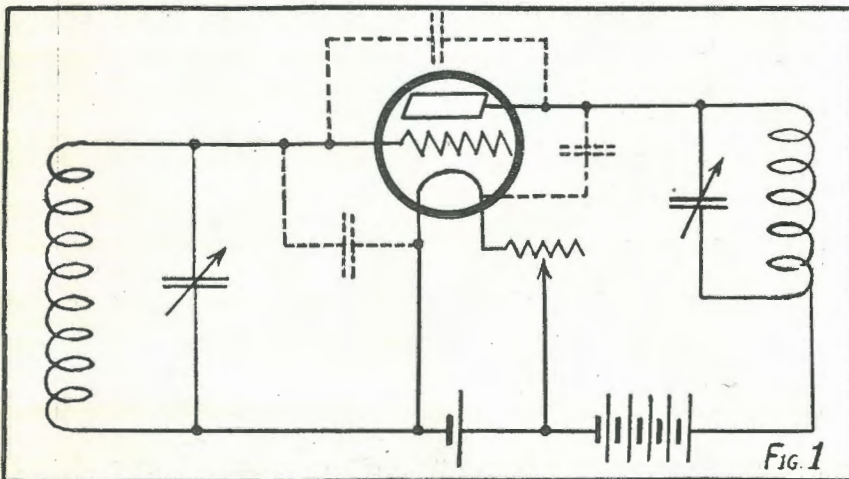

Fig. 1.—The dotted lines indicate the capacity that exists between the valve electrodes.

speech or music, and lastly, and perhaps most common of all, a rattling or grating noise forms an unpleasant accompaniment to the broadcast item.

With the exception of atmospheric disturbance and interference caused by other receiving stations in the neighbourhood, operating their sets about the oscillation point, these noises are due to incorrect design, faulty operation, or loose connections—and they can be corrected.

The object of this article is to outline briefly the causes of the whole gamut of receiver noises and to prescribe the cure for each one of them.

structions, otherwise you will have intermittent signals and a grating noise in the headphones. Where possible, connections should be soldered. Telephone cords should be tested for continuity; an intermittent connection will sometimes be found here.

See that the valve legs are making good, tight connections in their sockets. This also applies where plug-in coils are used in the tuner or for coupling purposes. Sliding contacts on filament resistances and potentiometers should make good contact at all adjustments.

B batteries are usually tapped in  $4\frac{1}{2}$  volt steps. Each section should be tested separately, and if only one or two sections are defective these should be cut out of circuit and reception may be carried on with the remaining good cells. When an accumulator is used for filament lighting it may become noisy if allowed to discharge below the limits laid down by the maker. After charging, the top of the accumulator should be wiped dry to prevent current leakage between terminals.

#### LOW INSULATION.

Valve sockets constructed of inferior insulating compositions, faulty grid leaks and low insulation in condensers and transformers are prolific sources of noisiness. If you want the best results and true and noiseless

reproduction avoid, apparatus of inferior quality as you would the Coogee (Sydney) surf when sharks are about.

In the case of transformers, low insulation causes a marked reduction in amplification as well as noise. Buzzing, and a regular ticking noise may be due to a grid leak of too high resistance, especially when using reaction, or regenerative coupling.

Attention to the foregoing should effectively kill the rattling or grating brand of noise.

When the receiving station is situated close to an electric power station or power lines pass close to the aerial, interference in the form of a low frequency buzzing sound may be experi-

enced. This is passed on to the receiver by induction.

To obviate this the aerial should be erected, where practicable, at right angles to the power lines.

Where the induction is due to electrical apparatus such as transformers, motors, lifts, etc., using considerable power and being operated in the vicinity of a receiving set, it may be very difficult to cut out the disturbance. It may usually be very considerably diminished, however, by using a loop aerial, the directional property of which is made use of. In some cases it will be advantageous to change the earth connection from the water system, which acts as a sort of collector of stray currents, to a separate earth, such as an old bucket sunk a few feet in the garden. The connection should be soldered.

may sometimes be traced to the use of a common plate battery for several valves. The internal resistance of this battery provides a means of coupling between valves and causes interaction between them. This may be overcome by connecting a condenser of high value, say, two microfarads, across the terminals of the battery. If the "howl" does not disappear entirely try reversing the connections to the primaries of the low frequency transformers—one transformer at a time. The transformers themselves should be mounted at right angles to each other to obviate interaction. The need for care in the selection of component parts again becomes apparent. Low frequency transformers of reputable make will be effectively shielded to prevent interaction. When using dull emitter valves trouble may be experienced from what is known as microphonic effect. Owing to the low temperature at which the filament operates, the filament wire retains its metallic property of vibration.

When a loud speaker is used in conjunction with these valves acoustic interaction may be set up between the loud-speaker and the valves, resulting in a continuous howl. This may be overcome by turning the loud-speaker away or placing it at some distance from the receiving apparatus. The valve sockets should be mounted on spongy rubber to damp out the vibrations. In particularly obstinate cases the valves will have to be acoustically shielded.

#### HIGH FREQUENCY SQUEALS.

If, when the tuning controls are varied, the pitch of the interfering note varies in the earphones from a low hum to a high squeal, the oscillations may be attributed to the radio-frequency valves. Where reaction is used the reaction coupling should be reduced to a point where the receiver just ceases to oscillate. If the tuned anode method of coupling is employed and the anode coil is not used for reaction purposes it should be isolated as far as practicable from other parts of the circuit. This may be effected by mounting the anode coil on the base of the receiver instead of on the panel, and at right angles to neighbouring coils.

Capacity coupling between plate and grid circuits is responsible for a great deal of self oscillation (Fig. 1).

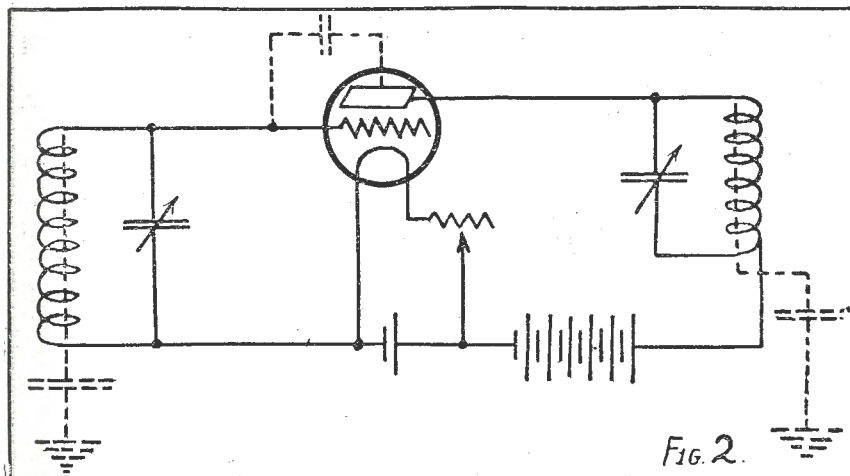

Fig. 2.—Indicating body capacity.

#### SELF OSCILLATION.

Other receiver noises of a more musical but equally annoying nature are due to self oscillation in the receiver. The oscillations appear in the telephones in the form of shrill whistling or lower howling notes. These noises may be due to oscillation in either the high or low frequency circuits, and before steps can be taken to eliminate them it must first be determined whether they are due to oscillation of the radio or audio frequency valves.

#### LOW FREQUENCY HOWLS.

If on varying the tuning controls no alteration takes place in the pitch of the "howl" the trouble probably lies in the low frequency circuit. It

This may be due to stray capacities in the wiring, or even to body capacity between the operator and the receiver, as depicted by the dotted lines in Fig. 2. When the operator comes too close to parts of the high frequency circuit at high potential, the body forms one plate of a capacity to earth and upsets the adjustment of the circuit. Long insulated handles on coils and condensers are sometimes used to overcome this.

From the foregoing it will be clear that the high frequency circuits should be wired up with care. The leads should be kept as short as possible and well-spaced. Plate and grid leaks should not be run parallel.

these conditions will be blurred and distorted, the best adjustments for clear reception being obtained when the tuning controls are set at a point just before oscillations begin. For your own benefit then, as well as to adhere to the exhortation of the well-known text "Do unto others," etc., *don't oscillate.*

The only cure that suggests itself for oscillations caused by your neighbour is to call on him—with an axe!

The foregoing list of receiver ailments may seem somewhat formidable, but in a well-designed receiver most of them will automatically disappear. The use of the correct type of valve for each particular function,

letter from the Principal of Nymboida, South Grafton, Public School, in which he tells of results obtained with one of this firm's "Burginphone" receivers. On the same night that the set arrived 2FC was picked up and items were heard 300 yards from the loud-speaker.

During the course of his letter he says: "I must thank your firm for its promptness in completing our order and hope to have all our wireless dealing made with your worthy firm when making purchases in the future."

From Tenterfield other reports have been received telling of recep-

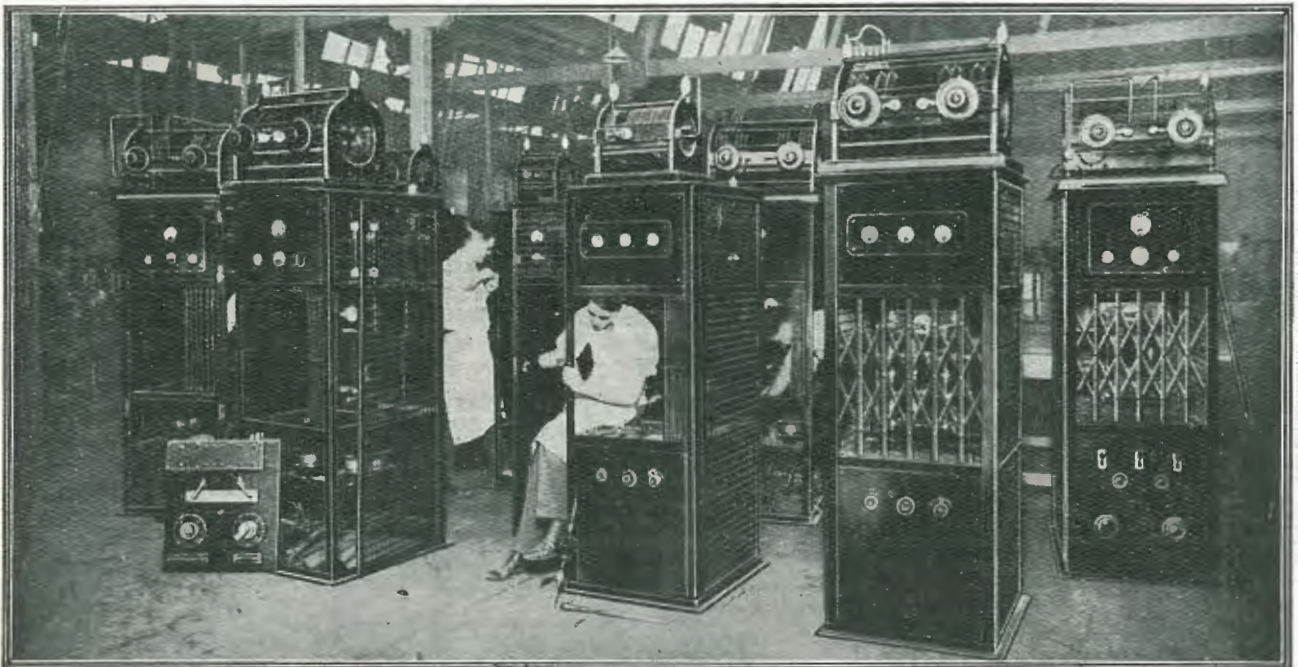

Eight Broadcasting Transmitting Panels in course of construction.

There is one other form of high frequency disturbance with which most listeners-in are familiar. This, as mentioned before, is the interference caused by your neighbour operating his receiver about the oscillation point. It should be remembered that when a receiver is in a state of oscillation, the oscillations generated are likely to react on the aerial—in other words, your set will become a more or less feeble transmitter and people operating receiving sets in your locality will receive the squeaks and whistles emanating from your receiver.

Moreover, telephony received under

and close adherence to the ratings laid down by the valve manufacturer will go a long way towards ensuring quiet and smooth operation. Do not attempt to work a loud-speaker with valves designed for detection or high frequency amplification. Use power valves for this purpose, in short—design or purchase your set, so as it will be equal to the task you are going to allot it, and you will be sure of pleasurable reception at all times.

### "BURGINPHONES" PERFORMANCES.

THE Burgin Electric Co., Sydney, write that they have received a

tion on a five-valve "Burginphone" of Melbourne and Sydney broadcast transmissions, while at Boggabri, where another receiver of this make was installed, 6WF, all the Melbourne and Sydney stations and N.Z. and KGO were picked up and heard on the loud-speaker with clarity and strength.

These receivers are manufactured by this company especially to suit Australian conditions, it being the firm's intention to create a big Australian industry in wireless.

# THE NEW

# "BECOLIAN"

## FOUR

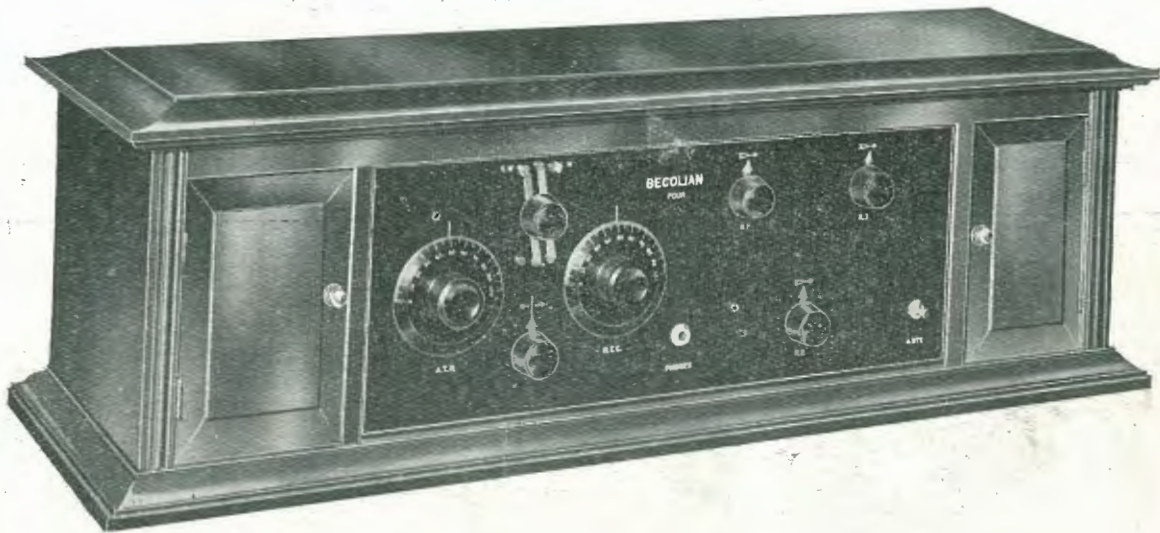

We take genuine pride in announcing this New Wireless Receiver—new in appearance, new in price, with further proof of the first-class workmanship incorporated in all our products.

The Cabinet work is pleasing and substantial, made of first-class Queensland maple, and well finished.

The general design of the "Becolian Four" provides for ease in working. Provision is made for the "B" Batteries to be fitted in the right-hand compartment, while spare coils, valves and head-phones can be located in the left-hand compartment.

*We are prepared to send one of our experts out to demonstrate these "Becolian" receivers on the condition that if such is satisfactory the purchase will be made.*

# £32:17:6

Complete with Loud Speaker,  
£49/17/6.

Telephone:  
City 141, M 3069.

## BURGIN ELECTRIC CO. LTD.

Telegrams:  
"Burgineco,"  
Sydney.

Wireless Manufacturers and Suppliers,  
340 KENT STREET, SYDNEY.

# A 60-600 Meter Tuner

(Reprinted by the courtesy of "The Wireless Age.")

By ROBERT ALAN.

CONSEQUENT upon the keen and universal interest which is being exhibited in short-wave wireless transmission and reception, we herewith publish particulars of a well-built and well-designed receiver which should secure for the constructor some very satisfying results.



TUNING down to 60 metres is impossible on the average broadcast tuner. In fact, you probably have never had that experience.

With the new 60-600 metre tuner, you can do just that and do it well.

But here is the big surprise. You can tune to 100, 200, 300, up to and over 600 metres on the 60-600. And

double cotton covered insulation. The single cotton insulation is not strong enough to withstand any rough treatment in the course of winding the coil, and the single-silk and double-silk-covered wire in this winding is not considered as good an insulation as the double cotton-covered. Before winding the coil, secure a piece of strong  $7/8$  inch wood, six inches

sections holes big enough to take a good sized six-inch spike. The holes should be of such size, so that the spikes can be removed. Then drive into these holes the thirteen spikes.

The windings should then be started. The plate coil comes first and consists of 45 turns of wire. The turns are made by going outside one spike and inside the next two then

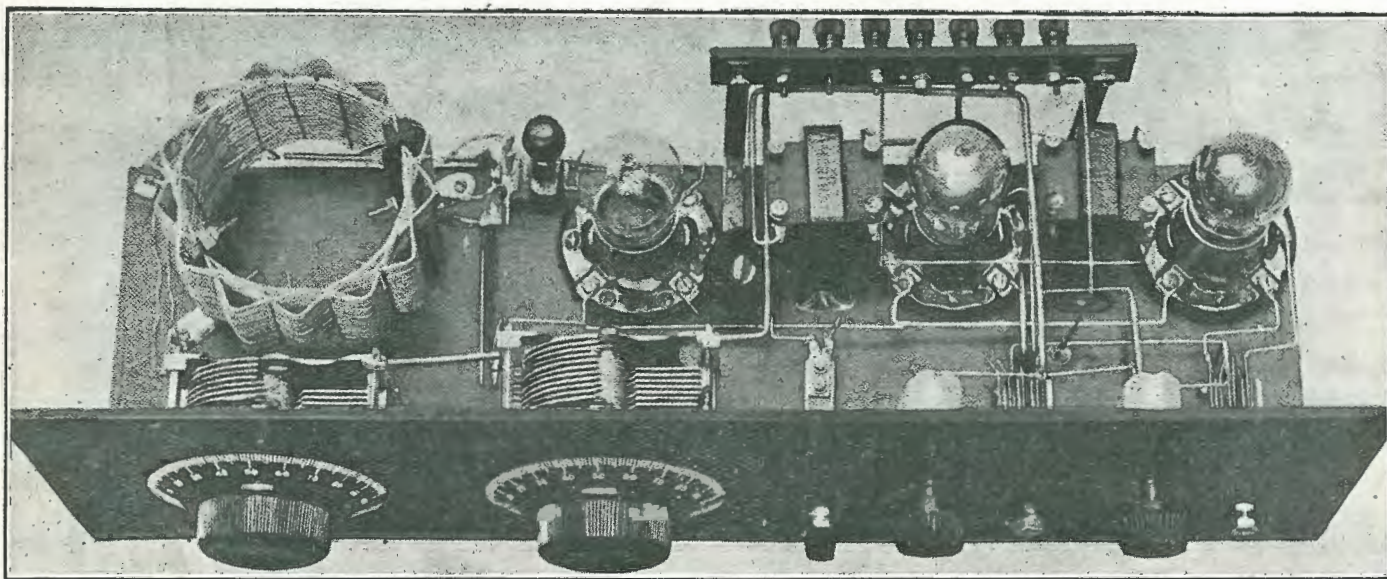

The clips for "shorting" the unused portion of the grid and plate coils and all other connections are clearly shown and no difficulty in placing parts or hooking-up the set should be experienced.

there you are: A tuner that tunes from 60 to 600 metres with a very high degree of efficiency over this entire range is worth something these days. You want to build one and do this, too? You do? Well, here's how.

## CONSTRUCTIONAL DETAILS.

The only part of this receiver which will involve any difficulties to the home builder is the construction of the tuning coil. This consists of about 90 turns of No. 18 D.C.C. To secure best results, it is best to use

square (we used  $\frac{3}{8}$  in. Dilecto, but the wood, if strong enough, will serve the purpose). Lay out on this piece a circle  $4\frac{1}{2}$  inches in diameter and divide its circumference into thirteen sections by the use of an accurate pair of dividers. Then drill at these inter-

outside one and inside the next two, etc. A tap is taken at the 30th turn. When this winding is completed, break the wire, leaving about eight inches of it for connection purposes, then right at the end of this winding start the secondary or grid winding.

Continuing in the same direction, wind eight turns of wire, which will form the antenna circuit. At the end of the eight turns, take off a tap and wind 40 more, which forms the grid coil. These 40 turns should be tapped at the 10th. When the winding is completed take several yards of 16

TEL.: CITY 4429

**Charles D. Maclurcan**  
CONSULTING RADIO ENGINEER

MACLURCAN & LANE, LTD.  
9-13 Brisbane Street, Sydney

pound test fishline and between the spikes where the wires cross, tie up the coil. At each cross section of the wire the coils should be fastened with

the coil. Angle brackets are then fastened to the bottom and secured to the baseboard. In the diagram there will be noticed the peculiar

form of tapping. In each case the lead from the grid and the plate is fastened to the extreme end of each coil. From this point there is a short

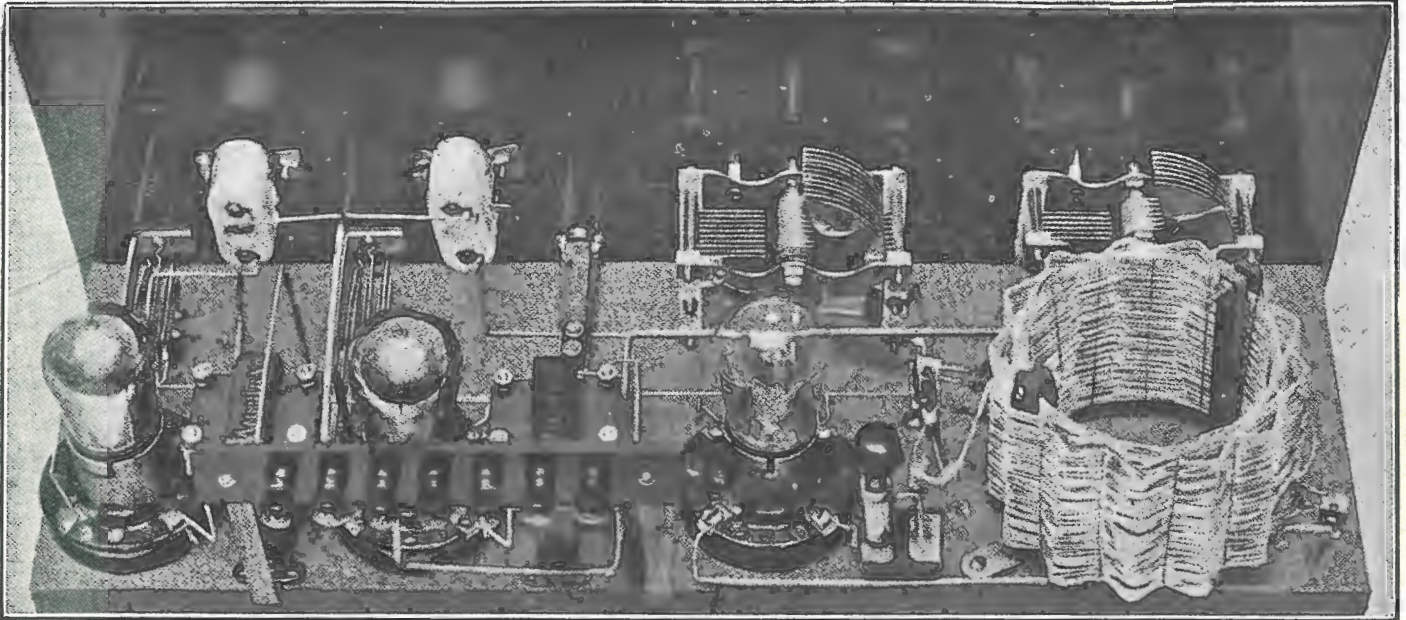

This illustration, together with the one on the foregoing page, should enable the most inexperienced to build the 60-600 Metre Receiver.

this fishline. When the coil is completely tied up remove the spikes and the coil. Now, to support the coil on the baseboard, take four one-half inch hard rubber strips one inch longer than the coil itself, and drill one-eighth inch holes one quarter inch

**LIST OF PRINCIPAL COMPONENTS.**

- 1 .000009 mfd.—.0005 mfd. variable condenser.
- 1 .000006 mfd.—.0003 mfd. variable condenser.
- 1 7 x 21 Radion panel.
- 1 7 x 1 Radion binding post strip.
- 1 Filament jack switch.
- 2 Bradleystats.
- 2 Audio frequency transformers.
- 1 .00025 mf. grid condenser.
- 1 1½ megohm grid leak.
- 4 Strips of hard rubber (4in. x 1½in.)
- 8 Lengths of bus wire.
- 3 Lengths of spaghetti.
- 1 6in. x 20½in. baseboard
- 1 Pound No. 18 D.C.C.

from the ends of each one. One strip is then put through the loop in the winding form and the other strip placed on the inside of the coil up against the winding, so that the two strips clamped together securely hold

# RADIO

Everybody's Getting a Thrill.

Listening-in to voices and music miles away certainly is thrilling. Our Sets get everything worth hearing.

"Leviaphone" Senior Crystal Sets

Guaranteed Braybrook Wave-length (20 miles radius) and complete with one pair of Phones, Aerial Wire and Insulators. Will carry three pairs of head-phones £3/3/-

For Long Distances—Special Valve Sets

Complete with Head-phones, Valve, Batteries, Aerial, etc. £11

WE STOCK ALL ACCESSORIES.  
Write for Illustrated RADIO CATALOG—Free.  
CARRIAGE EXTRA ON ALL SETS.

THE LEVIATHAN

PTY., LTD.,  
Cr. Swanston and Bourke Sts., MELBOURNE.

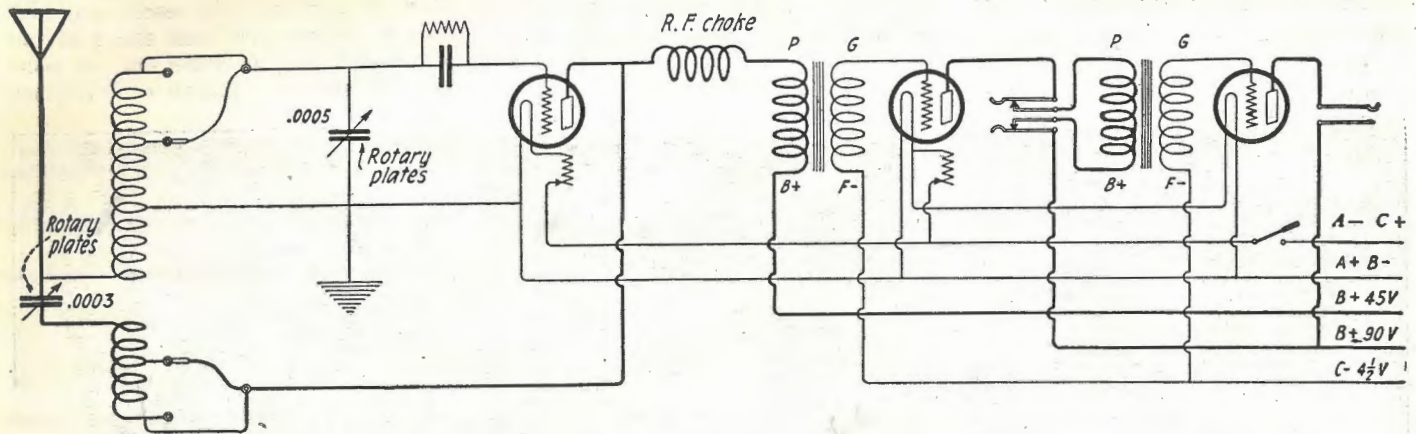

Circuit diagram of the 60-600 Metre Tuner, the efficiency of which is due to its simplicity.

length of wire at the end of which is fastened a Fahstock clip, which can be slipped over the end of the tap taken from the coil. This short circuits the portion of the coil which is not used. This arrangement is used in preference to a switching arrangement on the panel since it shortens leads and keeps the high potential parts of the circuit away from the hand of the operator. So much for the coil.

The audio-frequency amplifier and detector are mounted directly in back of the two Bradleystats and flush with the rear of the baseboard. The two angle brackets supporting the binding post strip are made out of a  $\frac{1}{2}$ -inch by  $\frac{1}{16}$ -inch copper ribbon, such as is used on oscillation transformers. The parts for this receiver were chosen because they worked well together.

Why go to the trouble of making an excellent coil like this one, with practically no dielectric losses and very low distributed capacity, and then tune it with a variable condenser which is nothing more or less than a poor grid-leak?

A receiving set is not better than its weakest part; and in this receiver we have combined necessarily the best of parts, but parts which we know will deliver the goods, and we have tried to build it like the "One Hoss Shay," each part as strong, electrically and mechanically, as its neighbour, so that when it does pass out of this life it will do so all at once. The wave-length range of this receiver has probably startled your attention into reading this far in the article. Please note that in the list of

specifications the minimum and maximum capacities of the two variable condensers were given. This receiver will cover this wave-length range only when condensers embodying this minimum to maximum range are used.

#### OPERATION.

When the set is completed check back your diagram to avoid blowing out perfectly good vacuum tubes, then connect up the batteries, turn on the filament switch and adjust the rheostats. The left-hand condenser con-

of three seconds, and it is a very simple matter to reach back of the panel and to change these two clips in about five seconds. After a careful operating test, we believe this set to be one of the best three-valve regenerative sets so far developed.

#### 2BL, NEW ZEALAND.

MR. H. W. BAKER, of Gladesville (Sydney), using a detector with two stages of audio, recently received

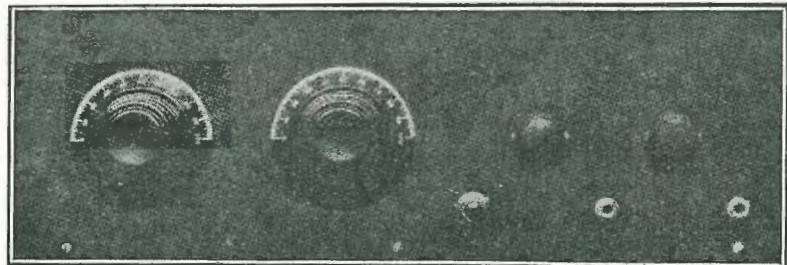

Front view of Panel.

trols regeneration and the right hand the wave-length. Using the entire windings of both coils, that is, with the shorting clip hanging in the air, the wave-length range is from 185 metres to a little over 600. When 30 turns of the secondary are shorted by means of the shorting clip, and 30 turns of the plate coil shorted in the same way, the wave-length range is from a little below 60 to close to 200. This method of changing wave-length should not be considered inconvenient, because one does not jump from amateur to broadcasting stations as a rule, within the space

a communication from 2BL, N.Z., the station of Mr. Fred White, Wellington. Mr. White's 'phone came through nearly as strong as many local amateurs, and C.W. was remarkably clear. At the time, 2BL was working on considerably reduced power, the input being about three watts, with 0.3 amps radiation. The test was carried out in daylight (4 p.m.—N.Z. time). Mr. White would like a card from Australian experimenters who may happen to receive his transmission; his address is:—Mr. Fred White, 46 Ellice Street, Wellington, N.Z.



**SHORT WAVE COMMUNICATION**

THE success of New Zealand amateurs on short wave-lengths was a wonder and surprise of the wireless world. The Government threw the amateurs the bone and they have done as well with it as they could have with the meat itself. Short wave-lengths are rapidly coming into vogue throughout the Dominion, and many amateurs are turning their attention to their use.

According to Mr. E. A. Shrimpton, Chief Telegraph Engineer, the position generally is rather a peculiar one. "Some time ago," he is reported to have stated, "amateurs clamoured for permission to transmit as well as receive. In complying with their wishes the authorities allocated to them wave-lengths of from 200 metres downward, to prevent them interfering with commercial stations. Great was the astonishment, however, at the results secured by the amateurs on these short wave-lengths.

"Perhaps the greatest advantage of short wave communication," continued Mr. Shrimpton, "is the facila-

tion of extremely close tuning, which is impossible with higher wave-lengths. Take two transmitters, of, for example, 365 and 365½ metres. With an ordinary type of receiver it is impossible to receive one without interference from the other. Go down on lengths below 100 metres, however, and it is possible to receive without interference a transmitter tuned to within a half a metre of another. Thus it will be seen that communication on these wave-lengths reduces the possibility of interference to a minimum. There can be no doubt," Mr. Shrimpton concluded, "that for some services short wave-lengths will be employed exclusively in future."

**LINKING UP THE ISLANDS.**

THE advantage of linking up the various islands of the Pacific by wireless was strikingly demonstrated when news was received in Wellington from the Chatham Islands of the striking and beaching of the steamer *Roma*. The steamer, which was formerly a British gunboat, was running under contract to the New Zealand

Government in the Auckland-Niue Island Service. Niue Island is one of the latest connections in the wireless system. A radio message was received from the Chatham Islands Fishing Company, announcing that the *Roma* struck while passing out from Kaingaroa and was leaking badly under the boiler, that she was being kept afloat with difficulty and would have to be beached. Full particulars by radio arrived later. Apart from giving information of trouble and distress, wireless is a tremendous boon to traders. The cargoes they handle are often perishable, and fruit suffers considerably if it has to await shipment for many days.

**I.Y.A.**

SINCE broadcasting has been resumed, IYA has been busy each evening of the week, as well as on Sundays. Delightful programmes have been sent out, and appreciative messages from all parts of the Dominion have been received. Some Southern critics regard IYA as New Zealand's best broadcasting station.

**MAKE THIS A RADIO XMAS WITH**

**WILES Wonderful Wireless**

**CRYSTAL or VALVE SETS Complete or for Home Construction.**

Parts for Single Slide  
Crystal Set . . . . 14/8

Parts for Loose Coupler  
Crystal Set . . . . £1/3/2

Parts for 1-Valve Set £5/17/9

Parts for 2-Valve Set £7/15/9

Parts for 3-Valve Set £9/15/-

Parts for 4-Valve Set £14/3/3

The only accessories you require to complete the above Sets are:—For Single Slider or Loose Coupler Crystal Sets: Headphones. For Valve Sets: Batteries, Headphones and Valves.

The parts for these Home-constructed Sets have been carefully tested, both individually and together, in the particular part for which they are intended. We employ a staff of experts to test out and find the right parts for whatever set you wish to build. Not the most expensive parts, nor the cheapest, but the right parts that will perform faithfully whatever is demanded of it by the particular set being built.

MAIL US YOUR ENQUIRIES.

SEND FOR PRICE LIST R5.

**BUY RADIO GOODS W. HARRY WILES FOR XMAS**  
**WHOLESALE AND RETAIL RADIO SUPPLIES,**  
**ESTABLISHED 20 YEARS.**

**384 PITT STREET**  
(NEAR GOULBURN ST.)

**56-58 GOULBURN STREET**  
(1 DOOR FROM PITT ST.)

**23 PITT STREET**  
(NEAR CIRCULAR QUAY)

Please address all communications to Head Office, 56-58 Goulburn Street, Sydney.

Mention "Radio" when communicating with Advertisers.

# Four First-rate Circuits

## Tried and Efficient



BELOW and on a following page we publish that which should gladden the heart of even the most hard-to-please "hook-up" fiend. Four circuit diagrams of four tried and efficient receiving sets are shown and these should enable the enthusiast to spend some interesting hours in their construction and also to experience some thrilling moments when he tunes in the DX stations.

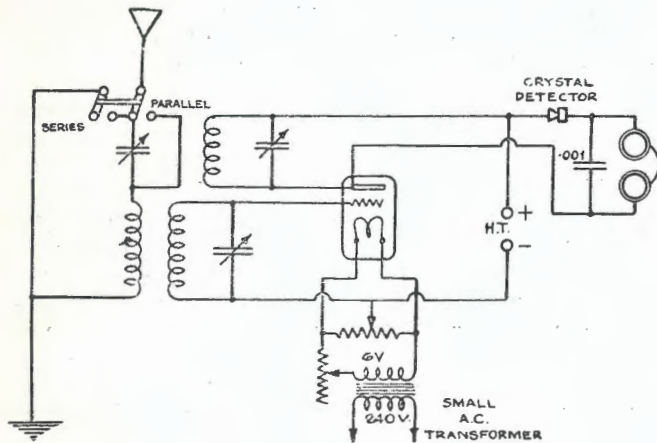

**LEFT.**  
Regenerative Receiver employing Valve as Radio Frequency Amplifier with a Crystal Detector as Rectifier. Alternating Current is used for Heating the Filament.

**RIGHT.**  
Inductively Coupled Valve Regenerative Circuit Utilising One-Stage Radio Frequency Amplification by Transformer Method and One Rectifying Valve.

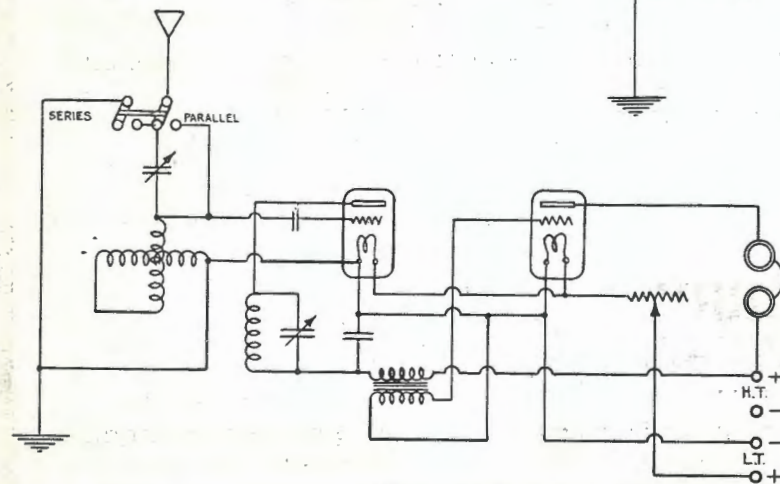
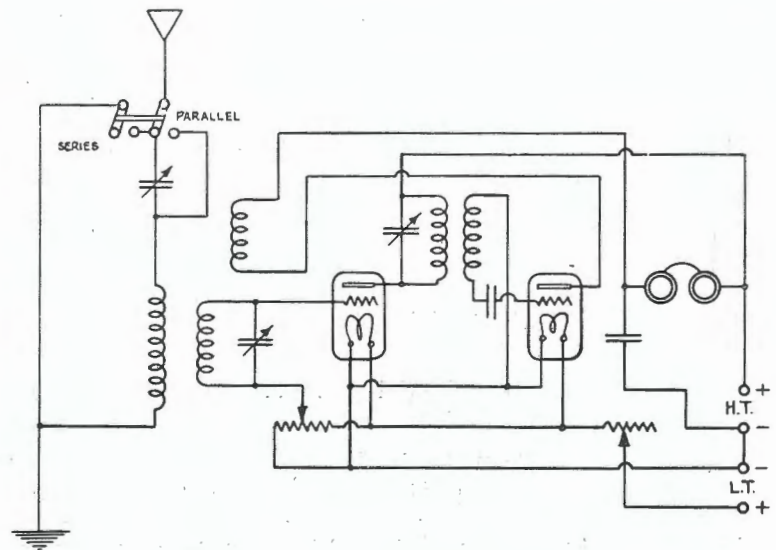

**LEFT.**  
Direct Coupled Valve Regenerative Circuit with One-Stage Audio Frequency Amplification.

IN the first diagram, the value of the aerial tuning condenser should be .001 mfd., and the two remaining variable condensers .0003. In the second diagram the aerial condenser is of .001 mfd. capacity; secondary condenser, .0003 mfd. capacity; the condenser connected in parallel with the transformer is of .0005 mfd. capacity, and .002 fixed condenser across high tension battery and telephones. In the third diagram the values of the variable aerial and secondary condensers are the same as the second diagram. In the last diagram the values are as follow:—Aerial, .001 mfd. (variable); secondary, .0003 mfd. (variable), and condenser across high tension battery, .001 mfd. (fixed).

The grid condensers in all these circuits have a capacity of .0003 mfd. (fixed).

The radio frequency bi-pass condenser in the third diagram is of .001 mfd. fixed capacity.

**RIGHT:**  
Direct Coupled Valve Regenerative Circuit Utilising One-Stage Radio Frequency Amplification and One Rectifying Valve.

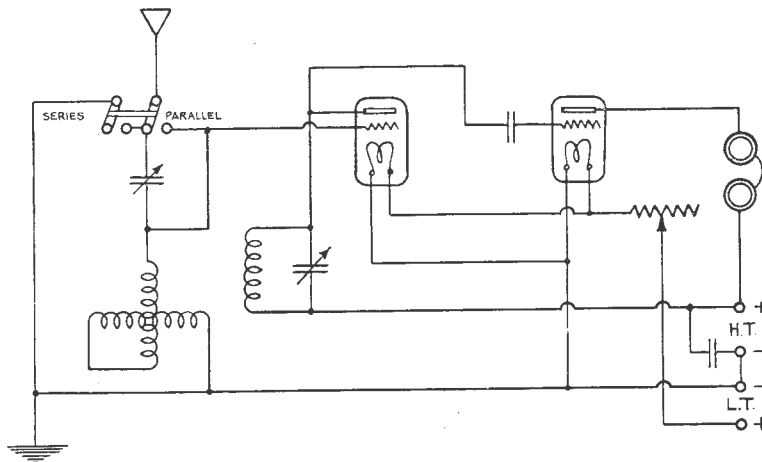

# GILFILLAN RADIO PARTS

BUILD THE BEST SETS.

They are Efficient, and last the longest.

ASK YOUR DEALER FOR GILFILLAN.

The detector unit comprises tube socket, filament rheostat of 20 ohms resistance, dial and knob, binding posts and solder lugs.

Jack can be mounted directly to bottom of unit so making exceptionally short leads possible and adapting the unit to radio frequency circuits.

The saving in time in using this article can hardly be appreciated until used.

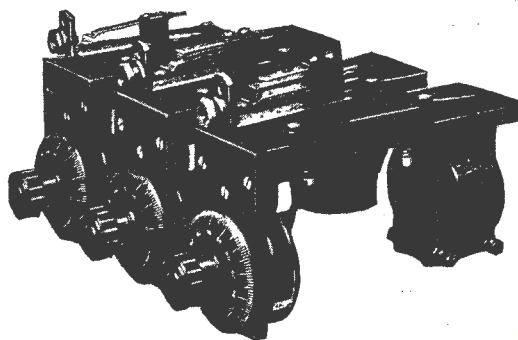

Bottom view of Gilfillan Detector Amplifier Unit showing method of mounting jacks and transformers, directly on unit, making short leads possible.

CALL AND INSPECT OUR NEW RADIO DEPARTMENTS AT

*Harringtons* LTD

386 GEORGE STREET, SYDNEY.

- |                                     |                     |
|-------------------------------------|---------------------|
| KATOOMBA .....                      | Katoomba Street.    |
| MELBOURNE .....                     | 266 Collins Street. |
| ADELAIDE .....                      | 10 Rundle Street.   |
| BRISBANE .....                      | 93 Queen Street.    |
| WELLINGTON (N.Z.), AUCKLAND (N.Z.). |                     |

# Thermionic Tubes

in

## RADIO TELEGRAPHY AND TELEPHONY

by

J. Scott-Taggart, F.Inst. P.,  
A.M.I.E.E.

470 Pages. 388 Diagrams.

Price, 20/- nett.

Postage 6d.

This revised and enlarged edition of Mr. Scott-Taggart's work is the best and most complete book which this well-known author has given the public, and deals thoroughly with the valve in all its working phases. We recommend this volume to the experimenter, who, we are sure, will find it in every way satisfactory.

### CHAPTER HEADINGS.

Two-Electrode Valves and the Theory of the Thermionic Currents — The Vacuum Tube as a Detector — The Vacuum Tube as an Amplifier — Retroactive or Regenerative Amplification — Multi-Stage High and Low Frequency Amplifiers — Combined High and Low Frequency Amplifiers — Multi-Stage Retroactive Receiving Circuits — The Reception of Continuous Waves — Transmission of Continuous Waves — Transmission of Continuous Waves with Vacuum Tubes—Vacuum Tube Oscillators, Wavemeters, Capacity Meters, and other Measuring Instruments — The Vacuum Tube in Wireless Telephony — The Dynatron — Miscellaneous Vacuum Tube Devices — Recent Developments — New Invention for Selective Reception.

### THE WIRELESS PRESS

97 Clarence Street, Sydney.  
44 Market Street, Melbourne.  
Australasian Chambers, Wellington,  
N.Z.

## Modern Ship's Wireless

THE s.s. *Geraldine Mary*, which is being built at Barrow, as an addition to a fleet which carries paper from Newfoundland to England, is to be equipped with the latest type of wireless apparatus by the Marconi International Marine Communication Co., Ltd.

The main transmitter is a Marconi 1½ Kw. quenched spark set, capable of long distance working, similar to that carried by the largest vessels afloat. The receiving apparatus, which comprises a valve amplifier with crystal detector, is capable of adjustment for any wave-length now in commercial use up to 25,000 metres.

In addition to the ordinary navigating instruments, the ship will be fitted with Marconi direction finding equipment, which will enable the position of the ship to be plotted reliably in thick fog, or under adverse weather conditions which may prevent visual observations. The wireless direction-finder has proved to be of such value that the Commissioner of Lighthouses of the United States Department of Commerce has referred to it as the most important navi-

gational instrument provided for use on shipboard since the invention of the magnetic compass.

The *Geraldine Mary* will be one of the first cargo boats to carry a lifeboat wireless set. The case of the *Trevessa* brought to the public notice the fact that ships may pass within a few miles of a lifeboat full of shipwrecked people without being aware of its presence. It would have required only a small wireless installation on the lifeboat to enable the crew to make their plight known over an extensive area. The Marconi apparatus for ships' lifeboats has a quenched spark transmitter with a range under normal conditions of at least 50 miles. The receiving apparatus combines the "all-round" and directional principles, so that the lifeboat, having transmitted its circumstances to all stations in range, can first listen for replies from all directions, and then employ the directional apparatus to concentrate attention on one station only. The lifeboat can thus take a bearing on the answering ship or land station, and set her course towards it.

## Radio Department Enlarged

THE growth of the radio business of Harrington's Ltd., photo and radio warehouses, Sydney, has rendered it necessary to considerably increase the accommodation of their radio department. The extensive basement of their premises at 386 George Street, Sydney, has therefore been handed over to the radio department.

The new department, which was inspected on November 26 by a large number of leading business men and others interested in wireless work, is elaborate in every detail. No expense has been spared to make the showroom complete in all respects. The large stock, which comprises every radio requisite, is attractively displayed and contains the latest and highest quality radio receiving sets, which include the now well-known "Imperia" crystal sets, valve and crystal, valve sets.

To assist customers, an expert staff is available at all times, ready

to give any information or advice and to demonstrate any of the equipment. The new department is readily accessible from the ground floor of Harrington's premises by means of a stairway on the immediate right as one enters from George Street, or by the lift.

A most interesting exhibit in the department is the "Imperia" Special Model G seven-valve set which is to be installed in the Royal Alexandra Hospital for Children before Christmas.

QUERIES ANSWERED.  
COUPON.

"RADIO  
in  
Australia & New Zealand."

December 10, 1924.

**DE FOREST VALVES.**

WHEN Dr. Lee De Forest invented the three electrode valve, he made present-day radio possible and from that time right up to to-day, the name of De Forest had borne a world-wide reputation. Their manufacturers claim that these valves satisfy the requirements of the most exacting, being non-microphonic, do not sing or ring or howl, and use very little current.

For dry batteries the De Forest DV3 valve is used, and this is considered especially adaptable for camps and other places where no electric power is available. For storage batteries, on the other hand, the DV2 is utilised.

All valves of the above make are thoroughly inspected and tested during and after production and are guaranteed against defects in material, character and workmanship. Each valve is packed in an individual carton containing instructions for proper operation and connection.

**COMMERCIAL WIRELESS RESEARCH.**

THE wireless industry, by reason of its highly complex technical prob-

lems, is one which, from its early inception, has called forth the need of technical specialisation. Provision for coping with this phase was early made by the commercial interests,

staffs maintained by the commercial wireless interests.

In Australia no less a sum than £7,000 per annum is spent by Amalgamated Wireless (A/sia.) Ltd. in re-

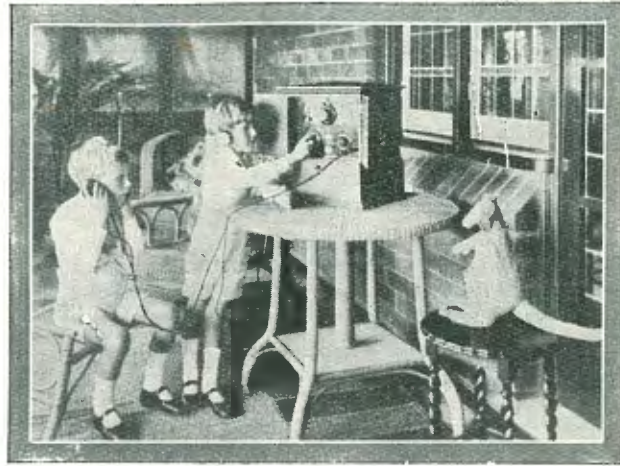

Listening to the most wonderful story in the world.

and the progress that has been made in every branch of wireless in Australia can be very largely attributed to the excellent work carried out by the trained research and engineering

search and experimental work, having as its objective the elimination of defects, the establishment of new principles, and more efficient or economical practice.

**ALL WIRELESS SETS AND REQUISITES**

ARE OBTAINABLE AT — LOWEST PRICES — FROM

**SWAINS, 119a and 123 Pitt St., Sydney**

A FEW DOORS FROM THE G.P.O.

CRYSTAL RECEIVING SETS, from 25/-. Operative up to 25 miles from Sydney.

ONE-VALVE RECEIVING SETS, from £5/10/-. Operative up to 100 miles from Sydney.

TWO, and UP TO SIX VALVE, from £28, Operative up to 5,000 miles from Sydney.

To INCREASE THE EFFICIENCY of YOUR CRYSTAL SET BUY OUR ONE-VALVE AMPLIFIER—Ready to connect up—Price £8; or the TWO-VALVE AMPLIFIER—which will operate a Loud Speaker—Price £9.

— WE SELL —

THE FAMOUS FROST FITTINGS, all makes of 'Phones and Loud Speakers — THE UNITED DISTRIBUTORS, LTD., HOME ASSEMBLY SETS and RADIOVOX SETS — STERLING 4-VALVE and 2-VALVE SETS, Loud Speakers and Phones — GALENA, ZINCITE, BORNITE, MOLYBDENITE, IRON PYRITES, AUSTRALITE CRYSTALS.

ALL THE LATEST BOOKS and MAGAZINES on WIRELESS in Stock.

**BE LOGICAL!**

Why pay sixpence for "RADIO" when you can buy it for a fraction over fourpence a copy?

Unless you are one of our subscribers, this is what you are doing!

By buying your copy fortnightly you are charging yourself three shillings more a year than you really need.

Add your name to our subscription list now and receive twenty-six issues of "RADIO" for twelve months for the small outlay of ten shillings.

The Circulation Manager,  
"RADIO in AUSTRALIA and NEW ZEALAND,"  
97 Clarence Street, Sydney, N.S.W.

Dear Sir,—

I enclose herewith 10/- (ten shillings) for twelve months' subscription (twenty-six issues) to "RADIO," commencing from the next number.

Please forward each issue of "RADIO" to—

Full Name .....

Address .....



**D**URING a terrific rainstorm in Chicago speech was broadcasted from an aeroplane and picked up by a commercial station on the ground, where it was re-broadcasted.

terest such a supervision should be imposed. One of the reasons that

foreigners and others are making use of the present absence of restrictions with the object of transmitting information which will adversely affect French finance.

## 6WF

### BROADCASTING TIMES.

Perth Mean Time.  
Wave Length: 1250 metres.

**Midday Session:**  
12.30 Tune in to gramophone.  
12.35 Market Reports of The Westralian Farmers, Limited.  
12.38 News Service.  
12.42 Weather Reports.  
12.44 Gramophone Items.  
1.0 Time Signal.  
1.1 to Gramophone and Pianola.  
1.30  
1.31 Close down.

#### Afternoon Session:

3.30 Tune in to Pianola.  
3.35 Special programme, comprising to Talks, Gramophone, Pianola, Westralian Farmers' Studio Orchestra.  
4.1 Close down.

#### Early Evening Session:

7.5 Tune in to Gramophone.  
7.10 Bedtime Stories.  
7.45 Market Report.  
7.57 Weather Report.  
8.0 Time Signal.  
8.1 News Cables.

#### EVENING SESSION:

8.10 to Entertainment.  
See list hereunder.  
Monday: 8.10, Lecture; 8.45, Westfarmers' Orchestra.  
Tuesday: 8.10, Professional Concert.  
Wednesday: 8.10, Theatre or Hall Broadcasting.  
Thursday: 8.10, Professional Concert.  
Friday: 8.10, Concert Evening and Lecture.  
Sunday: 7.29, Church Service.  
Saturday: 8.15, Westfarmers' Studio Orchestra.

#### SATURDAY:

**Midday Session:**  
12.0 Tune in to Gramophone.  
12.5 Market Reports of The Westralian Farmers' Ltd.  
12.10 News Service.  
12.15 Weather Report.  
12.16 Gramophone and Pianola.  
1.0 Time Signal.  
1.1 Close down.  
**Early Evening Session:**  
7.5 Tune in to Gramophone.  
7.10 Bedtime Stories.  
7.45 Market Reports.  
7.57 Weather Report.

**Evening Session:**  
8.0 Time Signal.  
8.2 News Cables.  
8.15 Westfarmers' Studio Orchestra.

## 3LO

### BROADCASTING TIMES.

Melbourne Mean Time.  
Wave Length: 1720 metres.

#### MONDAY TO FRIDAY:

**Midday Session:**  
12.55 Time Signals. "Argus" and "Herald" News Service, Reuter's and the Australian Press Association Cables.  
**Afternoon Session:**  
3.30 Musical programme.  
4.45 "Argus" and "Herald" News Service.

**Early Evening Session:**  
6.30 Children's Hour; "Billy Bunny" Stories.  
7.0 "Argus" and "Herald" News Service, Reuter's and the Australian Press Association Cables.  
**Evening Session:**  
8.0 Theatrical Items, Lectures, Vocal and instrumental items.

#### TUESDAY NIGHT.

Carlton's (St. Kilda) Dance Orchestra.

#### SATURDAY:

**Midday Session:**  
12.55 Time Signals, "Argus" and "Herald" News Service, Reuter's and the Australian Press Association Cables.

**Afternoon Session:**  
3.15 Musical programme.  
4.0 "Herald" News Service. Results of Races and other sporting events broadcasted immediately details received.

**Early Evening Session:**  
6.30 Children's Hour; "Billy Bunny" Stories.  
7.0 "Argus" and "Herald" News Service, Final Sporting Results.  
8.0 Vocal and Instrumental Concerts.

#### SUNDAY:

**Afternoon Session:**  
3.0 Pleasant Sunday Afternoon Services from Wesley Church.  
**Early Evening Session:**  
6.30 Children's Hour; "Billy Bunny" Stories.  
7.0 Church Service.  
**Evening Session:**  
8.30 Concerts from the Studio.

## 2FC

### BROADCASTING TIMES.

Sydney Mean Time.  
Wave Length: 1100 metres.

**Midday Session:**  
12.55 Tune in to the Studio Chimes.  
12.58 Time Signals from Farmer's Master Clock (Sydney Observatory Time), Stock Exchange Intelligence, Weather News, "Sydney Morning Herald" news and cable service, "Evening News" midday news bulletin.  
1.15 Close down.

**Afternoon Session:**  
3.30 Studio Chimes.  
3.33 Musical programme by Farmer's Orchestra broadcast direct from Farmer's Oak Luncheon Hall. Numbers will be played at intervals to 4.45.  
4.45 Stock Exchange, weather, afternoon news.  
5.0 Close down.

**Early Evening Session:**  
6.30 Studio Chimes.  
6.33 Children's Hour.  
7.0 Dalgety's Market Reports, Fruit and Vegetable Markets, Stock Exchange, Shipping News, Sussex Street Markets, Late News.  
7.15 Close down.

**Night Session:**  
8.0 to 10.0 Entertainment.  
See list hereunder.

### EVENING ENTERTAINMENT.

As far as possible the following schedule is adhered to:—

Monday: Theatre Night.  
Tuesday: Popular Concert  
Wednesday: Studio Concert.  
Thursday: Studio Concert.  
Friday: Classical Night.  
Saturday: Jazz Night.  
Sunday: Semi-Sacred Concert (7.30 to 9.30 p.m.).

FRANCE'S Government has given the Police Department special powers for the control of all wireless apparatus. As there are, it has been computed, something like 1,000,000 radio installations in the country, it would seem that in the national in-

have prompted the authorities to take this step is that it is feared that

IN these columns last issue we told a story of the "Wireless Widows." Now, from our point of view, comes the saddest story of all—the "Wireless Widower." He told us his tale himself and it greatly moved us. It appears that, like all good husbands

when he leaves the office for the day he goes straight home and, until he bought a radio set, like all good wives, his better half used to meet him at the front gate, while from the kitchen came the delicate and appetising aroma of a hot dinner. This idyllic set of circumstances continued for quite a while. Right up to the time, in fact, when the wireless apparatus was installed. On the first night after everything had been put in working order, the bread-winner returned home to find no welcoming arms at the door-step, nor came there any delightful odour from the culinary centre which might have made glad the heart of a tired and hungry man. The reception was, to say the least, of it, chilly. But this was as nothing compared with the greeting received after a long and patient wait. In response to his knocks his wife at last opened the door two inches, said, "Ssssh!" and rushed off to the lounge. From her retreating form came the explanation: "I could not come before—I'm listening to bedtime stories!" (No more now are the neighbours nightly entertain-

ed with the dear domestic scene which was outlined at the head of this para-

evening waiting with open arms for her spouse. No longer does the faint but revivifying breath of roast beef creep along the hall and meet Mr. —'s expectant nostrils. He dines at the club!) 'Tis very sad.

## 2BL

---

### BROADCASTING TIMES.

Sydney Mean Time.  
Wave Length: 350 metres.

**Midday Session.**  
12 } Musical Programme, with News  
to } Reports supplied by "The  
2 p.m. } Guardian."

**Afternoon Session.**  
3 } Musical Programme, with News  
to } Reports supplied by "The  
5 } Guardian."

**Early Evening Session.**  
7 Nursery Rhymes and Bedtime Stories.  
7.45. Pitt, Son & Badgery Stock Exchange Reports.

**Night Session.**  
8 Nightly Concert.

**EVENING ENTERTAINMENT.**

Monday: "Jazz" night, with vocal items from the Studio.

Tuesday: Classical Studio Concert.

Wednesday: Dance Night.

Thursday: Broadcasters' Popular Concert.

Friday: "Jazz" night, with popular items from the Studio.

Saturday: Popular Concert.

Sunday: Classical and Operatic Concert.

STUART and DON DEANEY, sons of Mr. J. D. Deaney, M.L.A., Warrnambool, V., have constructed a wireless set by themselves which we are informed has been valued by a wireless expert at 200 guineas.

ON November 19, at the North Sydney Police Court, Charles Scharke, James Tomlin and Clarence Waldron, all of Lane Cove, were prosecuted and each fined £2 with 25/- costs, in default 21 days' gaol, on a charge of having, without authority under the Wireless Telegraphy Act, maintained appliances for the purpose of receiving messages by wireless telegraphy. These were the first prosecutions of this nature to be launched in N.S.W. Since then several others have followed.

graph. No more does Mrs. — stand on the front doorstep at 5.40 every

**Have You Seen** The new Gramophone Attachment for utilising your Gramophone as a Loud Speaker. It is simply fitted to the Tone Arm in place of the ordinary speaker. It has a beautiful tonal quality on account of its adjustable Mica Diaphragm. Price, with Long Flexible Cord, £2/2/6.



C.I.C. Loud Speaker Gramophone Unit, £2/2/6.

**NOW, ABOUT VALVES AND HEADPHONES!**

We make a Special Carton for sending Valves to the country. It is almost impossible for the postal people to break a valve packed in this carton.

**The New Prices of Valves.**

PHILLIPS, D1, D2 and E .. . . .	18/6
MARCONI, R .. . . .	19/-
MULLARD .. . . .	19/-
DE FOREST .. . . .	30/-
RADIOTRON .. . . .	30/-

**Headphones of High Quality that we Stock**

PEERLESS SPECIAL, 2000 ohm .. . . .	27/6
TRIMM, 2000 ohm .. . . .	32/6
TRIMM, 3000 ohm .. . . .	45/-
RED SEAL—the Aristocrat of all Headphones	45/-



SEND FOR OUR PRICE LIST.

**RADIO HOUSE, 619 George Street, Sydney**  
THE QUALITY RADIO STORE.

# Two-Way Communication with England and America

By MAXWELL HOWDEN, A3BQ.

SPECIAL TO "RADIO."



FOR two or three months I have been using five Philips' Z2B's in parallel but at the beginning of November I changed over to a single Z4. This caused the input to drop about 50 per cent., while the

to call him at 7.15 the following night (Monday, November 3), and he would then tell the Yanks he had worked my QRH, and ask them to listen for me.

However, being home earlier than usual, I was out in the shack by 7

I did my best to answer him, and he certainly managed to read me, although local "hams" say they never heard such fearful sending. I admit my hand acquired a double phase vibration in place of the usual single, but it couldn't have been too bad. Anyway, he came back again and said my signals were good, besides a whole lot more that I lost in the fast increasing static. When he had finished this, I told him that his signals were now practically unreadable through QRN, and that I would see him again the next night at 6 p.m. Melbourne time. He acknowledged this and said G.M.

The next day, being Cup Day, I was out again at 6 p.m. and called U6AHP for quite a time, but, as I half expected, he had not bothered to work out just how his time compared with 6 p.m. Melbourne time, and thought I meant the same time as before.

Whilst waiting for him to wake up, I logged U9BCD, 2KC, 6AHP (calling N.Z.), 6LJ, 6CGO, and many others, whose calls I was not sure of. On the tick of 7, U6AHP called me, and we worked for about twenty minutes, but atmospherics were by that time again too bad for reliable reception at this end, although he reported me QSA.

UNTIL you learn to properly adjust your receiving set, do not condemn it.

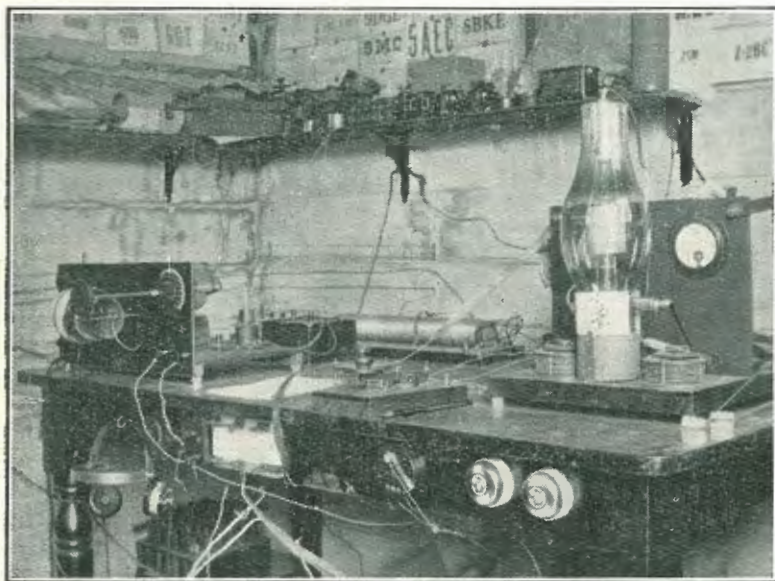

A3BQ.

wave-length—owing to the far lower capacity on the same adjustments—dropped still more.

I was then reported by the New Zealanders to be in fit condition to get across to U.S.A. In fact, Z2AC was kind enough to arrange with me

p.m. and, finding nothing coming through on my new "lower-loss" receiver—except static—I changed over and sent eq once or twice, and on changing back was surprise to hear U6AHP calling me and asking me QRK?

## Wireless Receiving Sets Made to Order

I am prepared to make sets of any design, either complete or parts only.

# VICTOR MARKS' Radio House

BEAMISH STREET, CAMPSIE.



At 7.55 6CGO called 3BQ, A U 6CGO QSA hr QRK? I went back and told him a lot of nice things about his sigs., etc., and am sure he said much the same about mine; but it would be exaggerating to call it working him.

Early the next evening the signals were very weak, and I could not copy 6AHP, but they improved a bit as darkness set in, and at 9.4 p.m. U1SF answered in CQ.

I arranged to work him during the week-end, when I hoped conditions would be better and also sent him a list of calls heard, which he acknowledged.

The conditions here went from bad to worse from then, until Sunday, 9th, when signals came in strongly again, and I then had the pleasure of working U1SF (Mr. Frizzell, of Boston) from 8.30 until 9.32 p.m. with 3JU, 3LM and Z2AE all listening in and taking turns at the key.

On Wednesday, 12th, when I had only a few minutes in the shack, I noticed that conditions were particularly good, and when at a meeting on Thursday, 3JU told me conditions were better still and 3BD said he had

heard a rumour that A2ME had been logged in England, I realized that if I could not QSO England the following morning, I never would.

Just before 5 a.m., when thinking of going back to bed I sent a CQ call on 86 metres, with radiation about 1.25 amps. On changing over I heard POZ working AHK and then at 5.3 a.m. a faint pure CW station calling 3BQ. It went on for about three minutes, calling nothing but 3BQ, until I was nearly frantic for fear the fast advancing daylight would blot him out before he signed off. Finally, however, he came to DEG 2OD, with an extra long dash at the beginning of the final "D," which made me think at first it was "Z." Once I had his call the tension relaxed, and having wiped the perspiration from my heated brow, I went back to him and worked him, with ease, until 5.27 a.m., when my signals appeared to fade. His only lasted a few minutes longer, but I got his O.K. for 18.00 G.M.T. the next day.

About mid-day on the same day (Friday) I received a cable from G2OD confirming first two-way com-

munication between Great Britain and Australia, and asking me to listen daily at 18.00 G.M.T. I cabled a reply which he acknowledged when I worked him the following morning from 5.6 till 5.14 a.m.

I worked 6CGO again that night, and also exchanged calls with UICK.

That concludes the two-way working to date, as, although I could hear him coming back to me from 4.31 until 5.14 on Sunday, 16th, he was mostly unreadable through the QRN.

There is nothing much of interest in the apparatus used, the circuit being a straight-out three coil series-fed Meissner, with quadruple spaced, home-made variable condensers across both plate and grid coils. The series condenser is in the aerial, and is not low loss, its ends being turned out of 3/16in. ebonite, and the washers cut out of brass tubing, with a hack saw. I have not noticed it smoking yet. The rectifier is 104 jar, bridge type, using sodium phosphate. This delivers 1500 volts at 110 M.A., when the line-voltage is normal. That has occurred once since I put in the Z-IV and the radiation on 86 metres was then 1.7 amps.

30/- EACH.

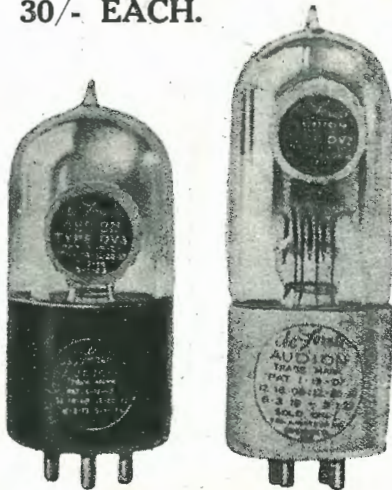

D.V. 3 Filament, 3 Volts, .06 Amp. Both Types Fit Standard American Socket. D.V. 2 Filament, 5 Volts, 25 Amp.

MADE BY—



THE MAN WHO INVENTED BROADCASTING.

### DE FOREST VALVES

TYPE D.V.2—Takes 5 Volts at 1 Amp. on Filament . . . . . 30/- each

Plate Voltages, Detector 18-22½ Volts; Plate Voltages, Amplifier 60-150 Volts.

TYPE D.V. 3—Takes 3 Volts at .06 of an Amp on Filament . . . . . 30/- each

Plate Voltage, 16-22½ Volts, Detector; Plate Voltage, 60-120 Volts, used as an Amplifier.

Both Types Fit Standard American Socket.

WHOLESALE ONLY.

# INTERNATIONAL RADIO CO. LTD.

200 CASTLEREAGH STREET, SYDNEY, N.S.W.

Phone: MA 1387.

Also at

91-93 COURTENAY PLACE, WELLINGTON, N.Z.

RADIO RADIATES CHEER.

# Loud Speakers



that offer you a choice of the best!

You cannot possibly make a mistake in selecting your Loud Speaker from these quoted below. United Distributors, Limited, hold the exclusive agency for these, because they can confidently recommend them for the most perfect results.

**THE MUSIC MASTER**—the de Luxe Loud Speaker—the standard by which all others are judged. Its amplifying bell of resonant wood gives the most natural delivery known to science .. . . . . . **£12**

Lower in Price but each supreme in its own class, are the following:—

**ATLAS LOUD SPEAKER**—"The Musicians of the Air"—reproduces the full, clear natural tones of voice and music as spoken, sung or played .. . . . . . **£7/10/-**

**SIGNAL LOUD SPEAKER**—Strong and sweet. Noteworthy for its attractive and original design .. . . . . . **£4/15/-**

**BRANDES TABLE TALKER**—Mellow as an old violin and just as beautiful in tone **£4/15/-**

What Could be a Better Present?  
**YOUR DEALER CAN SUPPLY THEM ALL!**

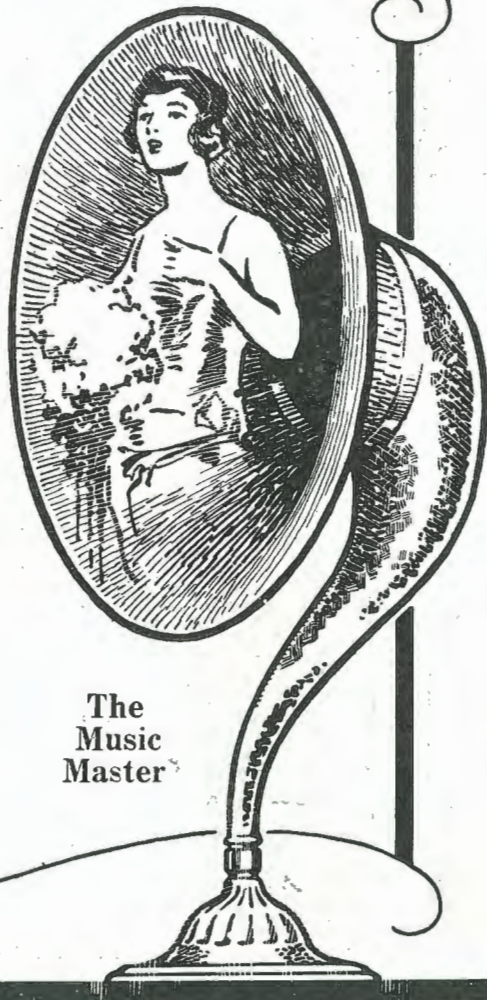

The Music Master

**UNITED DISTRIBUTORS, LIMITED**

(Wholesale only)

72 CLARENCE STREET, SYDNEY. . . . . 592 BOURKE STREET, MELBOURNE.  
and at Brisbane, Perth, Adelaide, Hobart and Wellington.

**HERE'S TO A CHEERY XMAS.**

# You can depend THOROUGHLY on Frost Guaranteed Parts

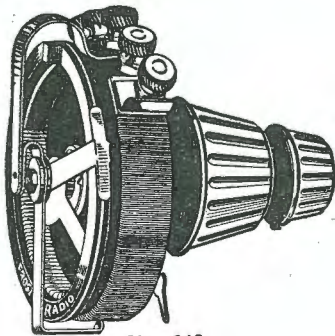

No. 610.

### FROST-RADIO Bakelite Tube Control Unit.

Called for Short: "Pot-Rheo." Made of maroon bakelite. Combines in one unit rheostat with vernier, and potentiometer, with two-knob control. All controls work with extreme smoothness. A valuable addition to any set.

- No. 607, 6 ohm Vernier and 200 ohm Potentiometer . . . . . 17/6
- No. 610, 35 ohm Vernier Rheostat and 400 ohm Potentiometer 17/6

### FROST-RADIO Rheostats and Potentiometers.

Precision adjustment. Pieces of apparatus that reflect quality.

- Nos. 650-2. Maroon Bakelite 6 and 35 ohm Rheostats . . . . . 7/3
- Nos. 651-3. Same with Vernier. . . . . 9/6
- No. 654. Maroon Bakelite, 400 ohm Potentiometer . . . . . 9/6
- Nos. 600-2. Metal Frame 6 and 35 ohm Rheostats . . . . . 5/6
- Nos. 601-4. Same with Vernier. . . . . 7/6
- Nos. 603-5. Metal Frame, 400 and 200 ohm Potentiometers . . . . . 5/6

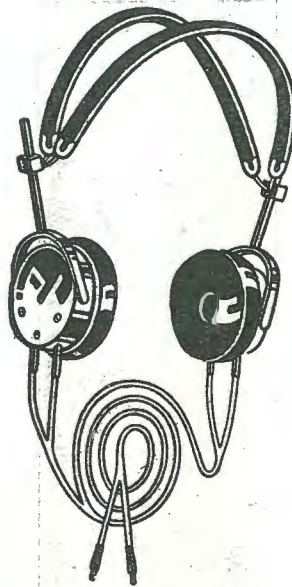

### FROST FONES.

Made with watch-like precision to respond to the extremely small electrical currents of radio reception. While remarkably sensitive, they also are sturdy for many years of use.

- No. 161. Frost Fones, 2,000 ohm, Aluminium Head Pieces . . . . . 32/6
- No. 171. Frost Fones, 3,000 ohm, Aluminium Head Pieces . . . . . 37/6
- No. 172. Frost Fones, 3,200 ohm, Maroon Bakelite Head Pieces 45/-

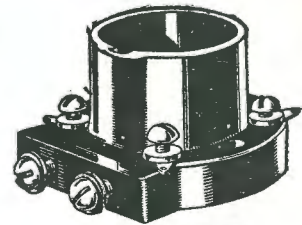

FROST-RADIO

No. 612.

### FROST RADIO Sponge Base Sockets.

- No. 618. Moulded Bakelite Shock Absorber Socket for standard Base Valves . . . . . 6/3
- No. 617. Same for U.V. 199 Valves . . . . . 6/3
- No. 612. Moulded Bakelite Vacuum Tube Socket, Bakelite Panel, Maroon finish, for U.V. 199 Valves . . . . . 5/-
- No. 107. Same for Standard Valves . . . . . 5/-
- No. 616. Compact gang of three Shock Absorber Sockets, for panel or table mounting, for U.V. 199 Valves . . . . . 24/6
- No. 619. Same for Standard Valves . . . . . 24/6

### FROST RADIO.

- Jacks, all styles . . . . . 4/6 to 6/6
- Plugs, double and single . . . . . 4/6 and 5/-
- 621. Parallel Switches . . . . . 5/-
- 608. Push and Pull Battery Switches . . . . . 4/-
- 400. Crystal Loose Couplers . . . . . 75/-
- 410. Crystal Tuning Coil Slider 27/6

**YOUR DEALER CAN SUPPLY ALL THESE!**

## United Distributors Limited

(Wholesale Only)

72 CLARENCE ST., SYDNEY.

592 BOURKE ST., MELBOURNE.

And at Adelaide, Perth, Brisbane, Hobart, Wellington.

## BACON & Co. Ltd.

PROCESS  
ENGRAVERS  
and  
ILLUSTRATORS

31a PITT STREET  
SYDNEY

'Phone: B 3368

KEEP IN TOUCH WITH  
RADIO PROGRESS  
IN THE MOTHER COUNTRY

By reading

The  
**Wireless World**  
and Radio Review

6d — WEEKLY — 6d

"The Wireless World," which commenced publication in 1913, is universally recognised as the Leading Authority on Wireless Matters.

It caters not only for the amateur, but also for the advanced worker.

Packed from cover to cover with really useful articles and diagrams, every week readers find something new and interesting, and, what is more important—RELIABLE.

"The Wireless World" still maintains its high reputation for being the

LEADING WIRELESS JOURNAL.

THE WIRELESS PRESS,

97 Clarence Street, Sydney, N.S.W.

## Australian Radio Engineers' Fine Feat



ANOTHER instance of what may be achieved by short wave, low-power wireless telegraphy communication was demonstrated last month by engineers of Amalgamated Wireless (Australasia) Ltd., when they succeeded several times in the course of some days in communicating with England, although only a



Mr. W. J. Martin, who in company with Mr. Hunter, received the experimental test messages in England from Sydney.

small experimental short wave transmitter was used.

The signals were first detected in England at the Marconi station, Hendon, at 6 o'clock on the evening of November 10, and reception was continued for the rest of the week.

During the whole time these experiments were in progress, Senator Marconi reports that the received signals were clear, steady and strong.

By this performance there has easily been effected a record for ratio of distance to wave-length, Sydney being 189,000 wave-lengths from England.

Commenting on the feat, Mr. E. T. Fisk, Managing Director of the Wireless Company, states:—"For some time past I have been desirous for the Amalgamated Wireless technical staff to attempt to communicate with England on low power but, owing to the pressure of more urgent work, this could not be undertaken earlier.

"Arrangements were made to transmit from one of our experimental stations in Sydney for short periods daily, commencing November 10, and the Marconi Company's experimental staff arranged to listen in England.

"After one day used to make adjustments, they reported having received our signals during part of the transmission at medium strength. The transmitting apparatus was entirely built in our Australian works, and was less powerful than the equipment used by mail steamers for communicating 1000 miles.

"This achievement should be considered as purely experimental, because the equipment and power used are unsuitable for the conduct of a



Mr. S. M. Newman, one of the Australian radio engineers who took part in the transmissions.

reliable service, but it is the first time in history that wireless signals have

been transmitted from Australia to England, and it serves to illustrate that with a properly designed station, higher power and beam transmission, high speed communication between Australia and England is certain. It further emphasises the fact that wireless is the means by which Australia's isolation can be effectively destroyed."

Others who received the experimental test messages in England were Messrs. W. J. Martin and F. A. Hunter, who used Australian-made valves, while Mr. F. Walker, of Walton-on-Thames, claimed to have heard the transmission using only a home-made two valve set.



Mr. F. A. Hunter, the Company's London representative, who, in company with Mr. Martin, received the signals.

**NEW ZEALAND SHIPPING REGULATIONS.**

IN order to comply with the new shipping regulations as applied to coastal vessels trading in N.Z. waters, the Northern S.S. Co. of Auckland have placed on order for emergency wireless apparatus as required by the Act. The sets will be installed on the following vessels:—s.s. *Matangi*, s.s. *Manaia*, s.s. *Ngapuhi* and s.s. *Rarawa*.

These are the four largest of the Company's vessels, and no doubt the experiment will be watched with interest by other companies.

**1AA TO INCREASE POWER.**  
OPERATOR Norman Edwards, of Z1AA, is considering the installation of a higher power transmitter, which will be somewhere in the vicinity of 50-watts. This station has already worked fairly long distance on low power and with the proposed increase should be able to do some remarkably good work.

**PERSONALITIES**

MUCH sympathy has been felt for Mr. G. Robins, radio inspector of Auckland, who is just recovering from a severe illness and we have pleasure in announcing that though his progress towards recovery is slow it is considered satisfactory. Mr. Robins' duties in the meantime are being carried out by Mr. O'Grady, operator in charge at VID. It is expected that duty will be resumed by Mr. Robins about the end of the year.

**"RADION" — the Supreme Insulation for Your radio receiving set**



When you build your receiving set you want to use absolutely the best insulating material that you can get. Nothing else is quite so important. The tone and audibility of the entire set depend to a great measure upon the insulation.

Radion has proved to be the supreme wireless insulation. It is made solely for radio work and far excels any other material in the four main Radio essentials namely:

- 1. Low Angle Phase Difference
- 2. Low Dielectric Contant
- 3. High Resistivity
- 4. Low Absorption of Moisture.

Radion also has a fifth very important characteristic—its workability. Even the amateur with ordinary house tools can saw, drill and otherwise work Radion Panels without the slightest danger of their chipping or cracking.

Radion Panels and Parts (dials, knobs, sockets, insulators, etc.) will greatly improve your radio set. Don't be satisfied with inferior substitutes when you can get genuine Radion.

Look for the trade mark stamped on every piece.

**International Radio Co., Ltd.,**  
91-92 Courtenay Pl., Wellington, N. Z.  
200 Castlereagh St., Sydney, N. S. W.

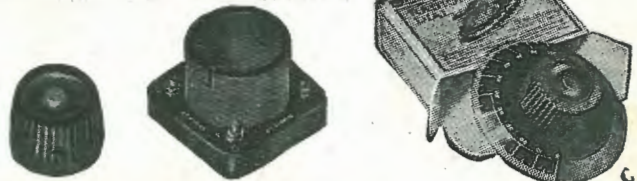

C41

"I NOTICE you ask for results obtained with the three-valve receiver published in *Radio*, No. 40," writes Mr. L. C. Campbell, of Lindfield (N.S.W.). "The one I made I consider is very successful. Some modifications, however, were made in that a series-parallel switch was used in conjunction with the aerial tuning condenser and a .0005 condenser instead of a .0003 specified. The valves used were three "201A" and "A.W.A.," 1 to 3½ transformers. During a recent trip to Lake Tabourie,

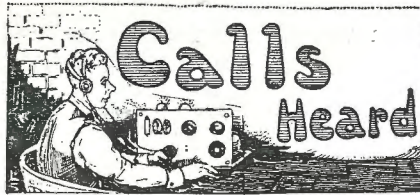

see what results could be obtained. For an aerial a single wire 100 feet long



Making Honeycomb Coils by means of automatic winding machines.

which is about 160 miles south of Sydney, I decided to take the above receiver and stretched between two trees up to a point about 40 feet high; and for the earth a

condensed milk-tin, to which was attached a length of 3/20 wire, was thrown into the lake, which, by the way, is salt water. The car battery was used for lighting the filaments. The results from 2FC were excellent. On the Sunday night the service from St. Mark's was clearly heard, and band selections afterwards. On the Wednesday, Sir Keith Smith's lecture on "Aviation," and on Thursday, the Conservatorium Concert were received excellently. Although signals from the loud-speaker, which is a "Baby Amplion," were not very great in volume, the quality was very clear. Farmer's were picked up best using coils of 75 and 150 turns, and Broadcasters using two coils of 50 turns each. For some reason or other, the latter were only picked up for about ten minutes and were then no longer heard. This, I think, proves, under the conditions, the receiver did all that can be expected.

"I WAS successful in receiving the special concert broadcast from WGY on November 13," writes Mr. P. Boulton, of Albury, N.S.W. "The station was picked up almost immediately after 2BL made the announcement at 8.30 p.m. that they would close down until 9 p.m. in order to give listeners an opportunity of hearing WGY." The American station's carrier was found to be very strong by Mr. Boulton, and three of the items were heard quite well on the loud-speaker and, although at 9 p.m. 2BL resumed transmission, WGY was held until nearly 10 p.m. Considerable fading was noted during the latter part of the evening.

## AN APPRECIATION

The Editor,  
"Radio."

Dear Sir,—

I would just like to express my thanks to you and your staff through this small letter of appreciation with regard to "Radio."

I have been a reader of this magazine from an early number, and it is more than I can say to express the way it has helped me along. I started with a small Crystal Receiver, and, like hundreds of others, after spending many intense moments trying to catch the sound of something on the air, I was rewarded with a gramophone selection from a local amateur.

But I was not satisfied with that; I wanted something better, and then came along the issue of "Radio" with the PI single valve receiver. After constructing that receiver I was more than pleased with the results that were obtained with it.

After my receiving broadcast programmes from Sydney (2FC) and Melbourne (3AR) and also numerous amateurs, came the issue with "How to Make a Loose Coupler," and it seemed as if you knew exactly what I wanted.

Then followed the diagram of a one-valve amplifier. So after constructing the set, which was then a two-valve, one detector and one amplifier and with a loud-speaker, 3AR and amateurs could be heard in most parts of the house.

But it was too much to ask of it to work a loud-speaker on 2FC, and so I was going to try and get hold of a good three-valve circuit when you published it, and now I am satisfied; it is all I want, and I must say that I hope other readers of this fine magazine have received the same results as I have.

I shall always continue to be a reader of "Radio."

Thanking you once again for your valuable services through "Radio," and assuring you that I will do my utmost to bring it under the notice of my friends.

"Yurunga,  
Westminster Street,  
Balwyn, Vic.

I am,

Yours faithfully,  
(Sgd) T. E. WILLIAMS, Jnr.

# The Home Constructor's Wireless Guide

By W. JAMES

## A Real Guide at Last

This is undoubtedly the best book published for those making their own wireless apparatus. We do not ask you to take our word for this. Examine the book, and you will agree. Questions are anticipated and answered or explained. Every part of Valve and Crystal Sets is thoroughly dealt with. Whether you desire to make transformers, variometers, vario-couplers, any type of coil or frame aerial, you will find it all in this book.

Not only does it tell you how to make apparatus but instructs you in the theoretical details and principles of wireless at the same time.

GET A COPY AT ONCE AND IT WILL SOLVE YOUR DIFFICULTIES.

Price - - - 4/6  
(Postage, 6d.)

OBTAINABLE FROM ALL BOOKSELLERS,

OR

## The Wireless Press

97 CLARENCE STREET, SYDNEY.

44 MARKET STREET,  
MELBOURNE.

AUSTRALASIA CHAMBERS,  
WELLINGTON, N.Z.

# How to Make an Audibility Meter

By Chas. D. Maclurcan.



WHEN comparing the relative strengths of wireless signals from distant stations the human ear is far from reliable, and it is necessary to adopt other means of more accurately effecting comparison.

Perhaps the simplest method employs an instrument usually called an

in the shunt is an indication of the strength of signals. For instance, if the signal is just audible when 99 per cent. of the detector current flows through the shunt and one per cent. through the telephone receivers, the signal is said to have an audibility of 100. If  $S$  is the impedance of the shunt and  $T$  the impedance of the telephone receivers, the audibility constant is given by the equation:—

$$K = \frac{S + T}{S}$$

So that supposing we use 2000 ohm telephone receivers, and the signals

From this it will be gathered that an Audibility Meter is nothing more nor less than a resistance box, suitably constructed so as to make it variable in steps of one ohm up to about 10,000 or 20,000 ohms.

The more elaborate forms of Audibility Meters are made with a compensating series resistance which is added in the plate circuit to allow for the reduction in resistance of that circuit caused by the shunting of the telephone receivers. The elementary connections of such a meter are shown in Fig. 1.  $R$  is the resistance used to shunt the telephone receivers and

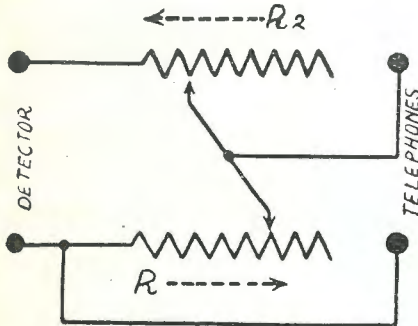

Fig. 1.—Elementary connections of Audibility Meter.

Audibility Meter and the object of this article is to describe briefly the Audibility Meter made and used by the writer, in the earnest hope that some enthusiastic experimenter in each State will make one up—and use it, so as to make life not only brighter for himself but a little less bright for his pals.

Now just a little theory first.

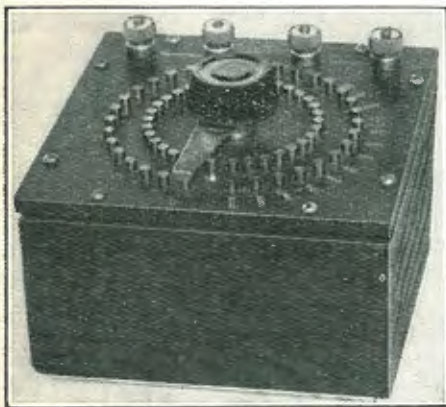

Fig. 2.—Exterior view of an Audibility Meter.

If a telephone receiver in which signals are being received is shunted by a resistance until the signals are just audible, the ratio of the current in the telephone to the current

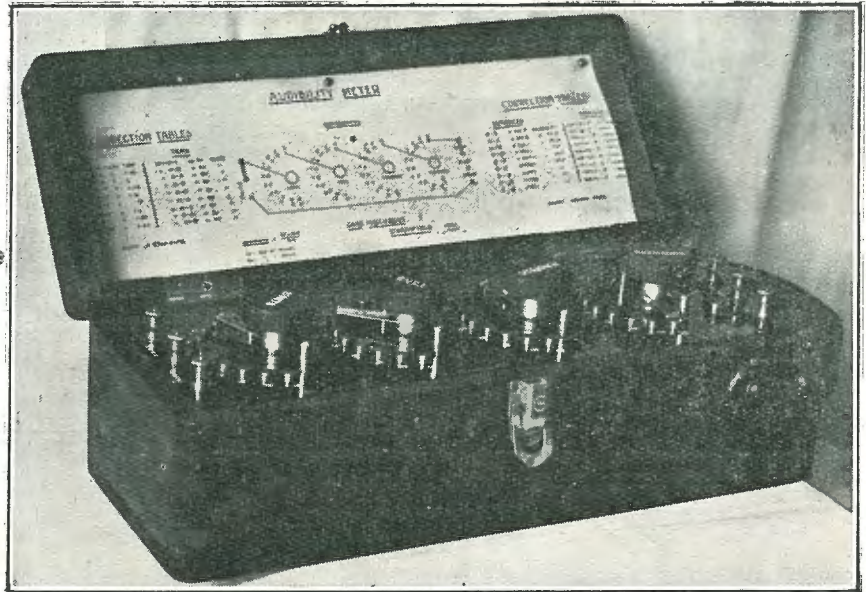

Fig. 3.—An Audibility Meter made by the writer. For connections see Fig. 4.

are just audible when we have reduced the shunting resistance across the telephone receivers to—say, 20 ohms, then the audibility  $K$  is

$$\frac{20 + 2000}{20} = \frac{2020}{20}$$

which is 101.

Or, supposing it takes 1000 ohms across the telephone receivers to reduce the signal till it is just audible, then our audibility is

$$\frac{1000 + 2000}{1000}$$

which is three.

$R_2$  is the compensating resistance. As  $R$  decreases  $R_2$  increases.

Fig. 2 illustrates this meter.

In Fig. 3 we have an illustration of the Audibility Meter made by the writer. The connections for this instrument are shown in Fig. 4.

It will be seen that there are four sets of contact studs with a moveable arm to each. The switch arms are engraved "units," "tens," "hundreds," "thousands," respectively. This means that between each contact stud is a resistance of the number of ohms indicated on the switch arm. So that between each contact stud of



# Brandes

*The Name to Know in Radio.*



*Result of  
16 Years'  
Experience*

**BRITISH  
MADE.**

**PRICE  
35/-**

**BRANDES**—the name associated with Radio Telephony for 16 years. A wealth of varied experience and experimental research has resulted in the perfect head-phones. The "Matched Tone" feature alone serves to make them of unrivalled efficiency. Each earpiece reproduces with equal intensity and the same degree of tone, thus ensuring sweetly resonant reception.

OBTAINABLE FROM ALL RADIO DEALERS.

Sole Australasian Distributors:

**Amalgamated Wireless**  
*(Australasia) Ltd.*

97 Clarence Street,  
SYDNEY.

Collins Street,  
MELBOURNE.

Manufactured in England by Brandes, Limited.

# Matched Tone

TRADE MARK

TRADE  
ENQUIRIES  
INVITED.

# Radio Headphones



**SPECIALY PRICED  
AT 15/-**

Previous Price was 22/6.

**VERNIER ADJUSTMENT.**

The Polar two-coil mount with vernier adjustment ideal for the popular P1 circuit, and specially priced at . . . . . 15/-

**High-Grade Transformers  
For All Purposes.  
From 21/- to 25/-.**

A full range of high-grade distortionless audio transformers at David Jones, including—

- Airad . . . . . 21/-
- Marle . . . . . 25/-
- Crosby . . . . . 27/6
- Jefferson 41 . . . . . 30/-
- Super Hetrodyne Transformers, Remler, 30/- and 35/-.

Radio Transformers at equally attractive prices.

Marle, Master, Amrad, Killbourne, Lelark, and the famous R.C.A., all wave transformer—200 to 5,000, at . . . . . 45/-

**DAVID JONES'**

*For Radio Service,*  
252 YORK STREET, SYDNEY.

**EDWARD WATERS & SONS**

(Established 1859.)

PATENT and TRADE MARK ATTORNEYS,  
CATHCART HOUSE,  
11-13 Castlereagh St., SYDNEY.  
Tel.: B 5987. (And at Melbourne).

Telephone: 1180 City.

FOR SERVICE

**GREEN & NORTON**

(Formerly the Rapid Freight Despatch Co.)

CUSTOMS, SHIPPING &  
FORWARDING AGENTS,

Broughton House,  
49A King St., SYDNEY.

the "unit" switch is a resistance of one ohm, between those of the "tens" switch a resistance of ten ohms and so on.

At one end of the meter are three terminals. Between the centre one and one outer terminal is a fixed resistance of 2000 ohms. The tele-

To those who have no means of measuring the resistances required, a table is given, showing the approximate resistance and lengths of insulated "Eureka" wire, which is suitable for this purpose.

There is one important thing to be remembered when connecting the re-

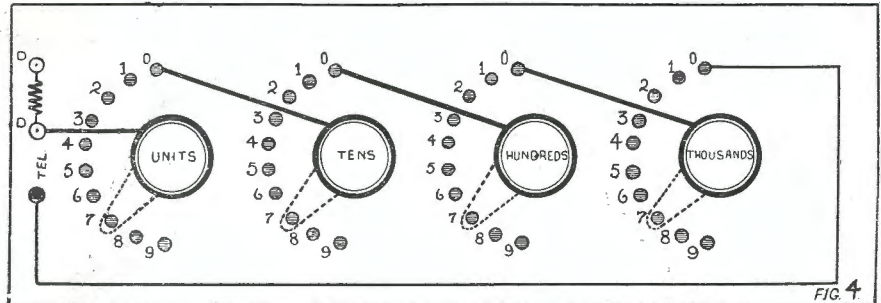

Connections of Audibility Meter illustrated in Fig. 3.

phones are connected between the centre one and the other outer terminal. This 2000 ohms is always in series with the telephones but is not shunted by the Audibility Meter. The leads from the receiving set usually

distance wire between the contact studs—that is, to wind the wire non-inductively.

Fig. 5 will show how this can be done.

First solder the correct length to

	GAUGE OF EUREKA WIRE.	OHMS PER YARD.	APPROX. AMT. REQD. BETWEEN STUDS.
Units . . . . .	No. 20 ..	6.6	.. 6ins.
Tens . . . . .	No. 22 ..	10.9	.. 33ins.
Hundreds . . . . .	No. 30 ..	55.75	.. 64ins.
Thousands . . . . .	No. 40 ..	371.8	.. 97ins.

connected to the telephones, go to the two outer terminals marked D on the Audibility Meter. By this arrangement there is always at least 2000 ohms resistance in the valve plate circuit which helps considerably in stabilising the measurements.

each stud, being careful not to damage the insulation except where it is to be soldered. Then stretch the bight of the wire down to a point. Commencing with the bight, wind the wire round a pencil or other small round object, bind with cotton and

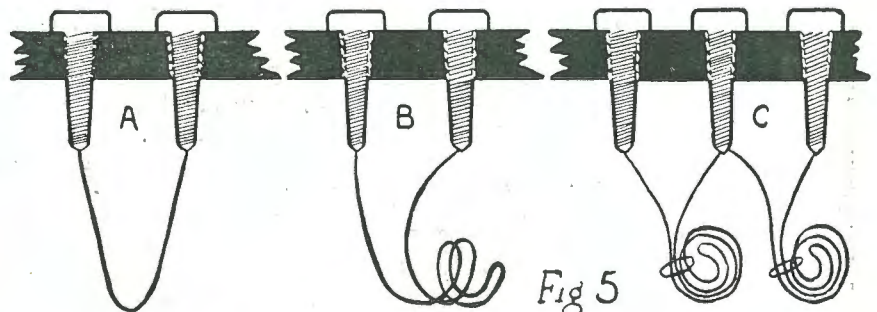

Showing how to wind the Eureka wire inductively.

Unless this resistance box is to be used for comparative resistance measurements these resistances need not be very accurate. A slight error in their value will not affect the audibility readings.

withdraw the pencil, leaving the resistance wire wound into a small compact coil between each stud.

An instrument such as this will prove an acquisition to any experimental station.

# Aerial Location and the Material to Use

NO matter what type of set you have, the location of your aerial or antenna is very important. It is a well-established fact that steel girders in buildings, gas tanks, bridges, trees and tin roofs, absorb radio energy and take just as much from your radio set and this means weak signals. Large buildings, hills and mountains deflect the energy and this also means weak signals.

On tests with a loop set, it was impossible to receive signals in a down-town office building due to the steel girders and lathes. The same set when installed in a residence gave excellent results in certain locations of the house but when placed near a radiator the signals were weakened a great deal.

True, an outdoor aerial will pick up energy whether it is between buildings or even lying on a roof but if it is properly located with respect to other surrounding objects, it will represent the difference between loud speaker reception and telephones. An aerial to be efficient should be put up above all surrounding buildings and with nothing between it and the ground. Of course, this is not practicable for the average city dweller who is lucky enough to get a good stretch from the front of his home to the rear fence or, as in the average case, just on the roof.

If you are in the latter class, put the aerial up between 15 and 30 feet above the roof, especially if it is

metal. A 15-ft. pole is a good average height above a roof that is not metal. The poles should be guyed and insulators inserted in the guys. The question has come up, why insulate the guys when the pole isn't insulated? Where possible to do so, it is a good idea to insulate the poles but this is not practical to most people. The idea in using insulators in the guys

signal strength if you place it high above your roof. We have heard people say, "I get as good results with my indoor antenna, as I do from the one on the roof." If such is the case, the one on the roof is poorly placed or the insulation is not good.

You can buy all sorts of insulators, some of them not as good as a piece of dry wood, so it is well to buy good insulation or none at all. Almost any old kind will do in dry weather, but it is in damp or rainy weather that good insulators show up. Glass and porcelain are both good. The cheap composition types are about useless as they soften in warm weather and crack in winter.

The kind of wire to use seems to bother many fans but, offhand, almost any kind of copper wire will do. You probably have read of the virtues of this or that kind of wire, braid or copper strip, but there is really little to choose between them. The main thing to keep in mind being to have a good conductor of electricity such as copper or silicon bronze. Four types of antenna conductors are shown in the drawings. A being copper strip, B solid copper, C stranded wire and D braid.

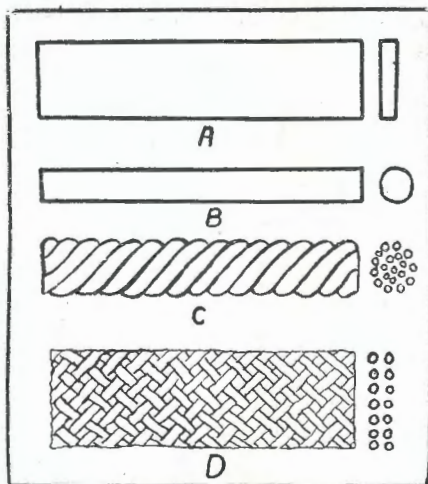

being to prevent the radio energy from grounding and the more parts you have insulated the less chance it has of getting to ground with a consequent loss of signal strength in your set.

You can pick up stations with an aerial stretched in your cellar, on the first, second or third floor of your home, but you will get much greater

If you are having trouble with your tuning coil using slider, the trouble may be in the contact between slider and rod.

THE primary of your set is connected to the aerial and ground.

## — QUALITY IN RADIO APPARATUS —

### STROMBERG-CARLSON

Radio Head Set, 2-A .. . . .	40/-
Loud Speaker, 1-A, with Cord and Plug .. . . .	£7/10/-
Transformer Audio, 3-A .. . . .	33/6
Transmitter, 7-L .. . . .	25/-
Radio Jacks, Plugs, etc.	

### JEWELL

Radio Measuring Instruments, built for accuracy and to last. A-B Battery Testers, R. F. Meters, Wave Meters, Valve Tester, Grid Leak Tester, etc.

DURHAM Variable Grid Leak, 2 to 10 Megs., 4/6.

Factory Representatives:

**L. P. R. BEAN & CO. LTD., 229 Castlereagh Street, Sydney**

Melbourne: H. G. SMALL & CO., 360 P.O. Place. Brisbane: S. H. SMITH, 299 Adelaide Street. Adelaide: CHAS. ATKINS & CO., LTD., 90 Currie Street. Perth: T. MUIR & CO., 99 William Street. Hobart: J. COOPER, 90 Harrington Street.

# What Happens Inside Your Battery

THE majority of persons using a multi-valve set operate the filaments from a storage battery and quite a number abuse this battery by letting it run down very low too often. This is done with the mistaken idea that "the battery in my car does not have to be charged." The battery in your car does get charged every time you run the car but the battery in your radio set is not connected to a generator and therefore must be charged by you regularly if you are

size of the plates, and ranges from 40 up.

If you have a four-valve set using 201A valves or similar ones, they will each draw  $\frac{1}{4}$  ampere, or the four of them one ampere. A 40 ampere battery would last about 40 hours (not quite as long as that in practice) while if you had a 100 ampere hour battery it would last nearly 100 hours. How often your battery requires charging depends on its

show minimum acid and maximum water, the acid having entered the plates. The negative plate has minimum lead sponge and maximum lead sulphate (shaded portion), while the positive plate has minimum lead peroxide and maximum lead sulphate.

When your battery is fully charged, each cell reads 2.5 volts and the specific gravity is at its highest. When discharged the battery will drop to 1.7 volts and the gravity will drop to 1.175. It should not be allowed to go below this as there is not sufficient voltage to properly heat filament and the battery has started to sulphate. Your battery should be charged at once, and charge it fully, not half charge it, otherwise the sulphate remains on the plates. When a battery is badly sulphated it requires a long charge to break it down and it must be charged at a slow rate, otherwise the active material in the plate may drop out.

A storage battery does not "store" electricity as is commonly supposed; it is the chemical action of the plates that produce electricity when connected together. The lead sulphate covers the plates on discharge and the acid cannot attack the active material, therefore no current flows and your battery is run down.

The best test for a lead-acid type of storage battery is a hydrometer, which is usually contained in a glass tube fitted with a rubber bulb and a rubber tubing, to be put in the battery. The bulb when pressed and released, draws the electrolyte into the glass tube and floats the hydrometer, which is marked over a graduated scale from 1.000 to 1.300.

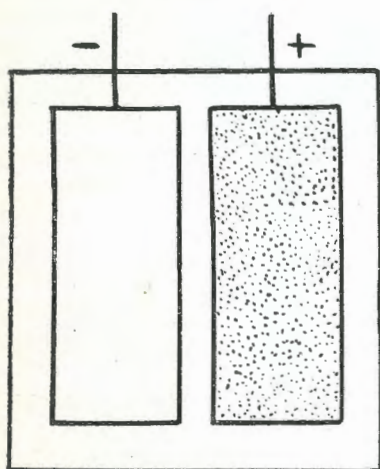
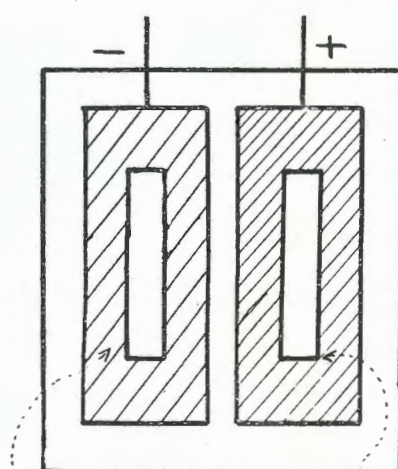

FIG. 1.



LEAD FIG. 2. SULPHATE

to get any degree of satisfaction from it.

In a radio set, the amount of current being consumed depends on the number of valves you are using as well as the type of loud speaker. The more valves you use and the oftener and longer you use the set, the more often the battery needs charging. Batteries are rated as so many volts and ampere hours. The ampere hours, or capacity, depends on the number and

ampere hour capacity, as well as the discharge rate of your valves.

In the drawings, Fig. 1 shows a battery fully charged. The negative plate consists of lead sponge and the positive lead peroxide. The solution is sulphuric acid and water. It is about a 20 per cent. solution. The solution should have a specific gravity between 1.280 and 1.300. Figure 2 shows a cell discharged; the electrolyte (water and acid solution) would

## WIRELESS PRESS PUBLICATIONS

New and revised Catalogue now available. Send Stamped  
 \_\_\_\_\_ and addressed envelope for Free Copy to \_\_\_\_\_

THE WIRELESS PRESS,

97 Clarence Street, SYDNEY.

44 Market Street,  
 MELBOURNE, VIC.

Australasian Chambers,  
 WELLINGTON, N.Z.

# *How it Got there*

—By the natural process  
of the cream of an  
Industry rising to the top

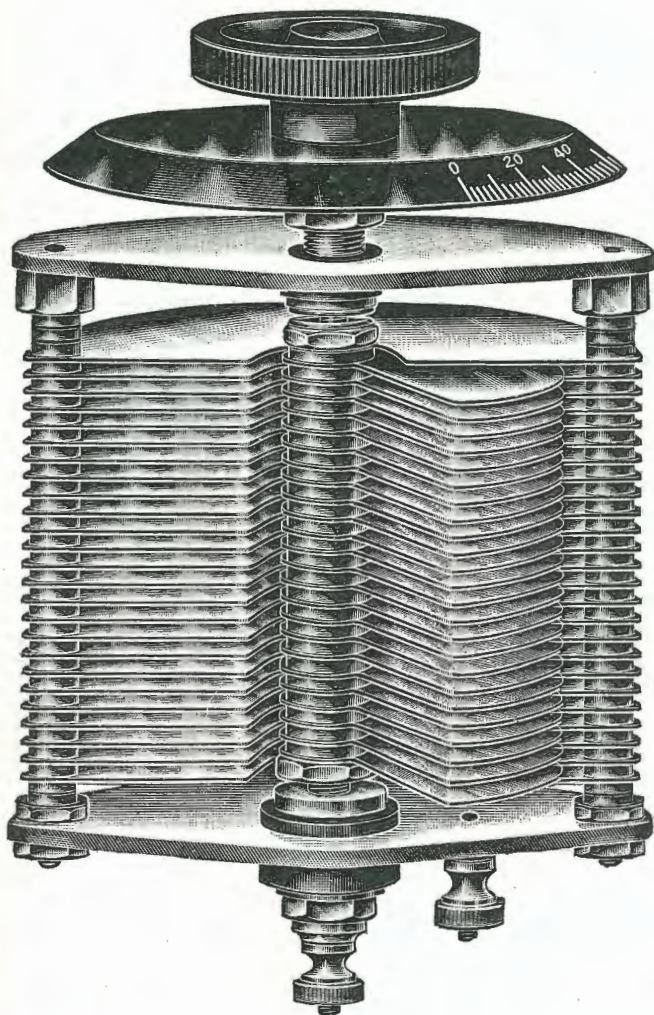

---

---

*Ask your Dealer for  
Ormond's No. 2 Condenser*

---

---

We Specialise in Turning Brass and Steel Screws and machined parts of all descriptions and accessories.

# ORMOND Engineering Co.

199 PENTONVILLE ROAD, KING'S CROSS - - LONDON, ENGLAND

## Our London Letter

(From Our Special Correspondent.)



TWO big wireless exhibitions were held in Great Britain during October—one at London and one at Manchester. The London exhibition, held at the Royal Albert Hall, opened on September 27, and closed on October 8. It was organized by the National Association of Radio Manufacturers, and was confined to exhibitors who are members of that body. About sixty firms were represented at the exhibition. The other exhibition was held at the Exhibition Hall, Manchester, from October 14 to October 26, and was a most

five, seven and a hundred miles respectively, and it has been estimated that 75 per cent. of the population of Great Britain are now within crystal range of broadcasting. This, of course, accounts for the noticeable increase in enthusiasm for crystal sets exhibited recently, as a complete crystal set can now be obtained for £2, needing no expense in upkeep, except an annual license fee of 10s., and occasional pence for new crystals.

### RELAYING AMERICA.

Reports are current that the British Broadcasting Company intends to

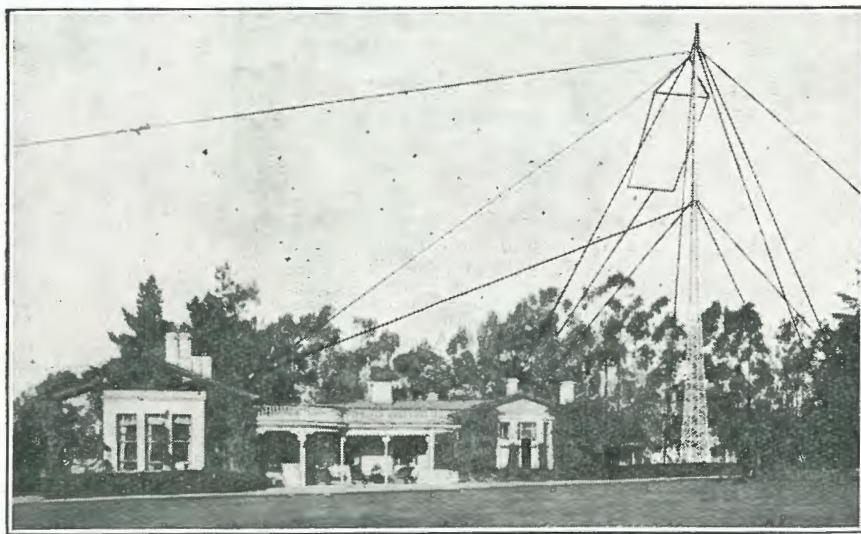

Here is a view of the aerial system at Z4AA, Mr. Frank Bell's Station at Waihem o, N.Z.

successful show to public and trade alike.

During the run of each exhibition, the British Broadcasting Company transmitted special programmes daily, which could be heard on loud speakers in specially constructed concert halls, and on the stands. The chief note of interest was the general all-round reduction of prices, in many cases 25 per cent. less than those ruling at last year's exhibitions. Crystal sets are now having more attention paid them than last year, owing chiefly to the opening of several new broadcasting stations and relay stations. There are now eight broadcasting stations, six relay stations, and one high-power station, with approximate crystal ranges of twenty-

relay American broadcasting again this winter on the same lines as last year—only, it is to be hoped, attended by something more in the way of success. Last year most of the transmissions were ruined by overpowering atmospherics, but as KDKA, the American station principally relayed, has increased his power enormously since last winter, better results are hoped for. If KDKA broadcasting is relayed by Chelmsford, working on 15 kilowatts, with a range of two or three thousand miles, maybe some other powerful station in the East will be able to pick him up and relay him, giving effect to the wireless engineer's dream of putting a wireless belt round the earth.

If you use a crystal detector and want to hear signals and speech louder and clearer than you ever have before you should buy **Sacrystal**.

# Sacrystal

is not an ordinary detector mineral; it needs care and intelligent handling, but the results from such attention will repay you a hundredfold.

# Sacrystal

gives the very best results with any metallic springy contact when the point is flat or blunt, and, once secured, adjustment is permanent.

Buy a piece to-night at your Wireless Dealers, but be sure the container is stamped **SACRYSTAL**.

**Retailed at 1/6 a box**

from all Radio dealers or from  
Miss P. SACHS,  
Knox Street, Randwick, N.S.W.

Phone: R'wick 580.

**BROADCAST MUSIC.**

As in all countries, fierce strife goes on here between the two types of amateurs—"high-brows," who like classical music and "low-brows" who crave for eternal dance music and jazz. These are, of course, the two extremes, as the average listener likes a little of each in moderation, and the BBC programmes certainly aim at supplying music to suit all tastes—an impossible task, of course, as no one programme can ever hope to satisfy several thousand listeners.

Since the commencement of broadcasting two years ago, we listeners have certainly been educated to appreciate classical music, and, I think, most of us do now genuinely find delight in this type of music, to which we would not listen before the advent of broadcasting. Though classical music may be stirring in the glare and bustle of a concert hall, sitting listening to it over telephones or loud



**WIRELESS SOCIETY OF NEWCASTLE.**

THE usual fortnightly meeting of the Wireless Society of Newcastle was held on November 19, in the Society's Rooms, Y.M.C.A. Buildings, King Street, Newcastle, with the usual good attendance.

At the request of the Technical Committee Mr. R. Filmer, a member of the Society, gave a short lecture on the various types of inductances used in receiving apparatus. The form of winding of each was followed by a keen discussion by members on the relative merits of the various inductances.

Members and intending members are asked to note that meetings are held on the first and third Wednesdays in each month to avoid possible confusion when there are five Wednesdays in the month.

**MR. T. R. ANTHONY'S CIRCUIT.**

IN response to the numerous requests he has received for a copy of the circuit with which he has secured such phenomenal DX results lately, Mr. Thomas R. Anthony, of Auburn, N.S.W., has asked us to state that, as the receiver which he is now using is of his own original design and construction, he does not yet wish to make the details public. Since Mr. Anthony's last DX list appeared in these columns he has succeeded in logging two English amateurs on only one valve. They were G2OD and G1KC—"which I am informed," he states, "is an Australian record."

speaker is inclined to render it more dull. The average listener, who two years ago would not even listen to classical music, has now got to the stage when he will tolerate it, if it possess rhythm—all, too frequently lacking, unfortunately—and perhaps in another two years we may even come to like it. However, at the moment the British programmes endeavour to strike the happy medium which will suit all tastes, and we have to rest content with that.

**BROADCASTING ABROAD.**

Reports are continually arriving of new broadcasting stations being opened in various parts of the world, and the United States still seem to lead the broadcasting field, with probably about as many broadcasting stations as the rest of the world put together, but if stations in other parts of the world increase at their present rate the American record will not be held for many more years—or months—to come.

**You can get it on a Wecoalve**

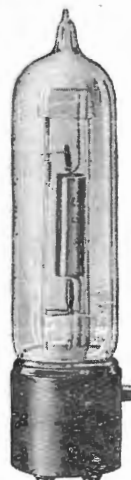

One of these little valves has given wonderful results to a Radio experimenter in Brisbane. He calls it "the little marvel, she stands on her dignity and I received 2 B.L. and 2 F.C."

K.G.O., Oakland, California, U.S.A., has been distinctly heard on TWO WECOVALVES, also 4 Y.A., Dunedin, N.Z., and 5 A.B., South Australia. Any Radio Dealer supplies Wecoalves.

*Something to get enthusiastic about*

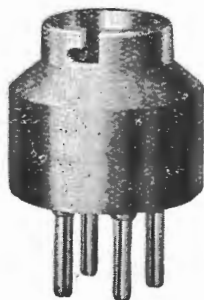

The Wecoalve Adaptor

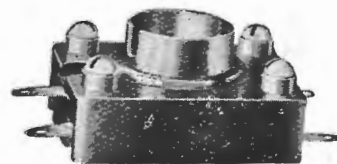

The Wecoalve Socket

Send for free pamphlet describing the all purpose WECOVALVE, which operates on dry cells—no accumulator necessary. They are particularly robust in construction and are entirely free from microphonic noises.

WECOVALVES are a "WESTERN ELECTRIC" product. A guarantee of reliability.

WHOLESALE ONLY FROM—

**Western Electric Company**  
(Australia) Ltd.

192-194 Castlereagh Street, SYDNEY

Telephone: City 336, 355 and 356.

Also at 588 Bourke St., Melbourne

# A Loose-Coupled Short Wave Set

AS short wave lengths are coming into the spotlight, an easily constructed set that will respond to wave lengths between 90 and 220 metres is shown herewith. It is the familiar three-coil set, with an untuned primary, variable condenser tuned secondary and an untuned tickler coil.

The primary consists of two turns of number 18 cotton-covered copper wire wound over the secondary, which has ten turns of the same wire; the tickler coil (T) consists of thirty turns of cotton covered copper wire, size 30 or thereabouts. The size of wire on the tickler does not make much difference.

The variable condenser is of .0005 microfarad capacity, and *must* be of the low loss type. The success or failure of this short wave set depends almost entirely on the grade of variable condenser you use. The fixed condenser should be of mica insulation, and the grid leak of the tubular glass inclosed type. The fixed bi-pass condenser should also be of mica insulation. Paper fixed condensers are not recommended in this set, which will be found very critical in its adjustment.

The low wave lengths now used by some of the large broadcasting stations during experimenting, travel as far during daylight hours as they do at night and for this reason a set of this type will bring in stations during the day that heretofore you only heard at night.

A long aerial may be used with this set, anywhere from 100 to 250 feet. There may be one spot on the condenser where the set will not oscillate, which will be at the fundamental

of the aerial, which shows that energy is being taken away from the grid circuit at that wave, not leaving sufficient energy to make it oscillate freely. This may be overcome by adding a 20-turn coil in series with the aerial when that adjustment is found. The coil should not be left in circuit except for that adjustment, as it will be found that another dead spot will be encountered elsewhere on the dial.

If you are fortunate enough to be using a three spider web coil set, you

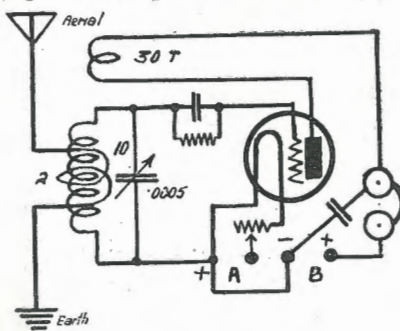

can very easily wind three coils to correspond to those shown in the drawing and convert your regular broadcasting tuner to a short wave one by plugging in the new coils. The flexibility of the three coil spider web set is one of the main reasons for it being the writer's "pet" circuit. It is excellent for short waves and broadcasting and, if honeycomb mountings are used, larger coils may be plugged in for any wave-length used to-day, as high as 25,000 metres.

The secondary coil of 10 turns can be wound on a  $3\frac{1}{2}$  inch composition tube and the tickler coil on a 3 inch

rotor form, either of the ball type or a tube similar to the 10 turn coil. The primary coil being wound directly over the 10 turn coil and the two turns spaced instead of closely wound.

## WIRELESS FOR WHALERS.

THE use of directional wireless reception is constantly extending and it is now being applied to the special requirements of vessels engaged in whaling operations. The whaler *Sir James Clark Ross*, which recently sailed from Cardiff for the Ross Sea, has been fitted with a Marconi direction finder, and is taking with her five others for use on board the small boats associated with her in whaling.

The *Sir James Clark Ross* is fitted with a Marconi three Kw. telegraph-telephone transmitter, which enables her to give instructions to the small boats when they are out on expeditions for whales. It not infrequently happens that the boats are overtaken by fog or darkness, and have difficulty in finding their way back to the parent ship. In such circumstances the direction finding apparatus will be valuable, since it will enable the boats to take bearings on the ship by means of her wireless signals and thus to feel their way back to her.

## NAME AND ADDRESS WANTED.

WE have received 10/- for a yearly subscription to *Radio* from a reader at Dubbo. Unfortunately, he has omitted to sign this name and address. If this new subscriber will let us have the required particulars we shall be glad to post him his first copy immediately.

4/- in £

## SMITH'S Radio Stores

4/- in £

### 3 VICTORIA ARCADE, Opp. HOTEL AUSTRALIA.

TO CLEAR OUR STOCKS OF XMAS COMMITMENTS.

## 10 DAYS' 20% SALE.

THIS APPLIES TO ALL NON-PROPRIETARY LINES, AND INCLUDES:—

HEAD-PHONES  
VALVES  
HONEYCOMB COILS  
CONDENSERS

LOOSE COUPLER PARTS  
SETS  
RHEOSTATS  
TRANSFORMERS



*Marconi Valves  
Mean Greater Efficiency.*

## The Popular "DE3" Reduced to 32/6

Popular because of its wonderful economy and great efficiency, the Marconi DE3 Valve has been accorded the unqualified approval of Australian radio enthusiasts. It gives equally as good results as an accumulator-heated filament valve and with an expenditure of only one-tenth of the filament current.

### *THE GREAT ALL-ROUNDER.*

The DE3 can be efficiently used as a detector, or a high-frequency or low-frequency amplifier; its low impedance renders it extremely suitable for use in conjunction with a Loud Speaker.

The anode voltage is from 20-80 volts.

*Obtainable from all Radio Dealers.*

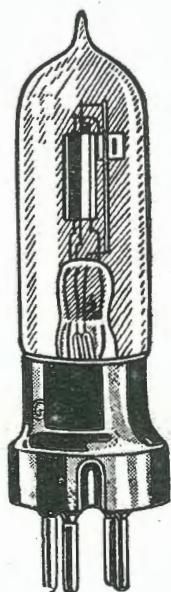

Price,

**32/6**

**Amalgamated  Wireless**  
*(Australasia) Ltd.*

97 Clarence Street,  
Sydney.

Collins Street,  
Melbourne.

# "Mike"

THE banquet was over. While the orchestra was playing its final number a serious young man slipped through the commotion up to the speaker's table. Producing the cre-

cast what was said and sung. Before the silk-covered cord had been wound around the base of the "mike," one of the speakers had turned to his neighbour.

"Same here," replied his companion. "Let's ask him to show us."

"Here you are," said the telephone man, pausing with the third microphone in his hand. A twist of his screw driver and the cover came off as neatly as a Greek opens an oyster. A newspaper man also drew near and gazed at his shiny, nickel-plated brother inside the bronze screen.

"It doesn't look much like the transmitter on your telephone," said the engineer, "but it follows the same principles and it was developed by the same group of engineers. These two heavy rings are the foundation, so to speak. Between them is clamped a metal diaphragm only a few thousandths of an inch thick. The diaphragm is stretched so tightly that if it were entirely free to vibrate it would do so at about 6,000 per second. By an ingenious 'damping' device we have raised the so-called free vibration frequency to somewhere around 9,000 per second.

"The damping device I just mentioned also makes sure that the diaphragm's motion follows the very complicated vibrations of the air. This metal plate which fills the back of the transmitter, and has a few 'breather' holes in it, is only a thousandth of an inch away from the diaphragm. The thin film of air acts as a door check on a microscopic scale, and tends to keep the diaphragm from over-shooting the waves it is supposed to follow."

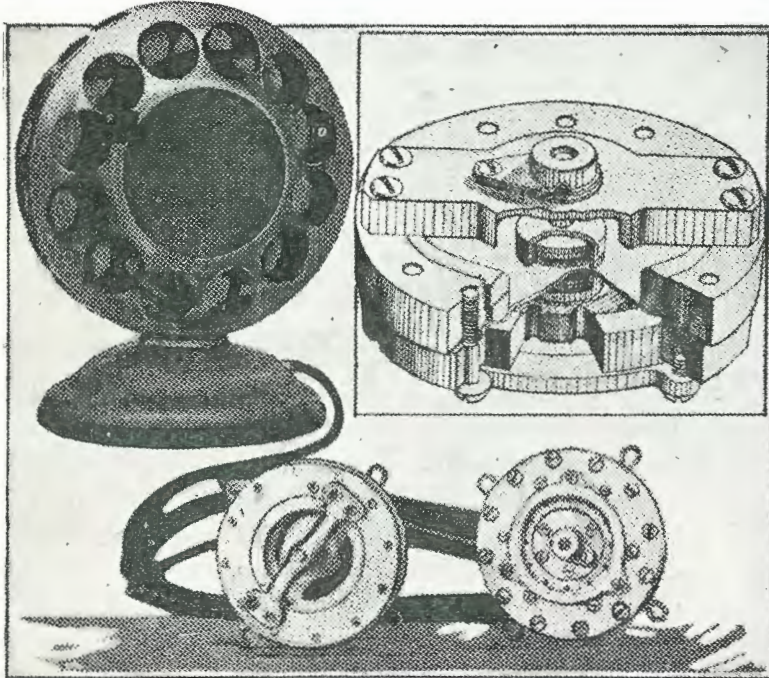

Upper left: "Mike" in evening dress. Inset: Showing his make-up. Below: Front and back of microphone, showing holes which admit air to one side of the diaphragm—his breathing apparatus.

dentials of the telephone man—pliers, cutters, and screw-driver—he deftly disconnected the nearest of the microphones which had been used to broad-

"Jim, I've had one of those things listening to my wit and humour many a time. but I've never seen what's inside it."

## INSURE WITH The Liverpool and London and Globe Insurance Co. Ltd.

ASSETS EXCEED £20,000,000.

LOWEST RATES.

FIRE — ACCIDENT — MARINE

Head Office for Australasia:  
62 PITT STREET, SYDNEY.

W. B. CLARKE, Local Manager for N.S.W.

Melbourne Branch:  
415-7 COLLINS STREET.

R. M. EVANS, Local Manager for Victoria.

C. DANVERS, Manager for Australasia.

T. M. DOUGLAS, Assistant Manager for Australasia.

"If you look carefully, you can see a bit of gold plating in the centre of the diaphragm, and just above it a ring of white felt. The felt is fastened to the edge of a brass cup, which holds a little pile of carbon grains. Current flows through the wires, into this insulated lug on the bridge, and so into a polished carbon disc in the bottom of the cup. Then it flows into the carbon grains, which rest loosely upon each other, and out through the gold plating into the transmitter structure. Then another wire leads it off to the amplifier downstairs in the control room. There is another cup filled with carbon grains on the other side of the diaphragm, and the two work into a single transformer in what we call the 'push-pull' connection. When sound waves strike the diaphragm they push it back and forth; and when the carbon grains in one cup are being pushed together, in the other cup they are slipping apart. So the current through one cup is increasing and through the other cup it is decreasing. In the transformer these two causes are combined to produce one effect. With this arrange-

ment the programme transmitted sounds more natural—the effect for which we strive.

"But the telephone company is always telling us to talk directly into the transmitter," said the newspaper man.

"While you can be several feet away and still be heard." The telephone man had picked up his thought before the words were spoken. "Here's the answer. Your telephone was designed all the way through to carry your ideas as economically as possible. The system we used tonight was designed to reproduce not only what you said, but in the same way that you said it—every syllable a faithful copy of the original tones of your voice. So we use a transmitter only one-thousandth as sensitive as the one on your telephone, and make up its lack of 'pep' by a vacuum tube amplifier. This amplifier goes further—it allows you to stand several feet away, and even move around a bit. If a speech is to be enjoyed, the electrical devices must not cramp the speaker's style, although, I will admit, that we sometimes give certain speakers the delicate suggestion that

they stand still and not ramp and stamp all over the platform."

Most of the tables and chairs had disappeared before the advancing phalanx of porters, but the little group was scarcely conscious of the commotion. Sensing that they were blocking the wheels of progress, the engineer proposed that they adjourn.

#### SEASON FOR WIRELESS.

IN connection with the splendid achievements recorded by Otago operators during October, it is interesting to note the general opinion of commercial operators, that in October of each year the best results for six hundred metre work at any rate are obtained. Mr. J. Davies, formerly Superintendent at Awaniu V.L.A., states that at this time of the year it was found always possible to work VEA, Esteban, Vancouver, an impossible feat at other times. This extraordinary transmission and reception applied to other stations at the same time. Whether there is a like effect with short wave-lengths, will be shown by the continuance or otherwise of the present two-way communications.

Buy a few parts so that your boy can make a Radio Set for Christmas.

Kilbourne & Clark parts are made with the finest attention to detail.

PROCURABLE AT ALL DEALERS.

# PACIFIC ELECTRIC CO.

(WHOLESALE ONLY)

87 CLARENCE STREET, SYDNEY.

B 5891

SOLE AUSTRALIAN DISTRIBUTORS.

# Keeping Your Set Spick and Span

THOSE of you who have had a receiving set for some time might follow the example of the good housewife and start a little radio cleaning instead of house cleaning. If you use an out-door aerial (and the majority of us do), it will be best to start there. Lower the aerial down, and you will be surprised at the condition of the wire, if it has been up for several months. Take it in your hands and bend it up and down as though you were trying to break it,

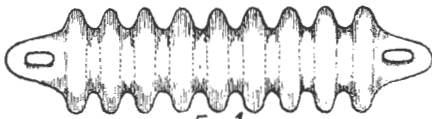

FIG 1.

and if it is brittle, it will be a good idea to replace it with new wire. Look at the insulators, that will no doubt be covered with dirt. Clean them off thoroughly, and if any are cracked, they should be replaced with good ones. The longer the surface of the insulator the better. An insulator 6 inches long and grooved as shown in Figure 1 will have much more surface than an 8 inch one as shown in Figure 2. By actual measurement, a 12 inch insulator has a leakage surface of  $17\frac{1}{2}$  inches. If you have any splices in the aerial, it would be a good plan to examine them now, for while it may have seemed to good joint then, it may not have been. While looking over your aerial you might as well give your ground wire and connections a close examination. If you are using a clamp, take it off

and you will more than likely find the point of contact will need cleaning again.

No matter what type of cabinet you are using, it is not dust-proof and you can do a little cleaning there. Dust has a bad habit of collecting on the plates of the variable condensers, and you hear scratching noises from time to time when they are moved. A pipe stem cleaner is as good as anything else to remove this dust. The nuts that hold the various connections should be tightened up if they are not soldered. Copper wire has a tendency to flatten out under the pressure of a nut and the connection is not then as tight as it should be.

The contacts of the sockets should be pulled up and polished up a bit, as they sometimes lose the springiness they had when new. Outside of the set just now working, you will have a hard time knowing whether the grid and plate prongs are making contact, but with the filament it is different.

A good way to remove dust from the inside of the set is to use a bellows. If you use a cloth you are liable to pull the various connections around.

The storage battery is often neglected, but should not be. The positive terminal may acquire a greenish deposit as will the positive lead to the set. If this is not re-

moved, it means a poor contact, and that means noises and reduced voltage. These noises have all the earmarks of atmospherics.

After you have given your radio equipment a thorough cleaning you will be rewarded by much better reception, and if you keep an eye on the items mentioned above and see they are kept in good condition at all times, you will be known as one whose radio set is always working well.

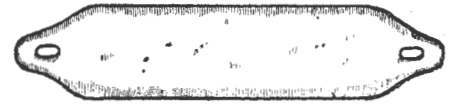

FIG 2.

IF you attach your aerial to a tree, have the aerial about 15 feet from the tree to avoid loss.

A CHEAP set will work much better with a good pair of telephones.

SOME parts made by machine are better than those you make yourself.

IN the long run the best material is the cheapest.

YOU may have read what some cheap set did in the line of distance work, but the average cheap set will not do it.

YOUR lead-in counts in the wave length of your aerial. Be sure it is insulated well.

## "The Theatre, Society and Home"

LIKE WIRELESS IT TOUCHES ALL PARTS OF THE WORLD

After Reading Please Pass on to a Friend. Larger Circulation Means More Advertisements :: More Advertisements Mean Extra News, Pars, and Home Chatter.

PUBLISHED MONTHLY. SOLD BY ALL BOOKSTALLS.

HEAD OFFICE: 16 BOND STREET, SYDNEY.

Branches: 100 King St., MELBOURNE; 75 Elizabeth St., BRISBANE; 32 Waymouth St., ADELAIDE.

# An Explanation of Radio Circuits

TO understand a radio circuit you must first know what is to be accomplished by the various parts of the circuit from picking up the radio signal to reproducing it in its original form as produced in the studio.

In radio and audio frequency type of sets we have six different portions of the set such as the collecting agency; tuner; radio frequency amplifier; detector; audio frequency and reproducer. The collecting agency may be an outdoor, indoor or loop aerial. The tuner may consist of a single coil; variometer; vario-coupler and variable condenser; two variometers; vario-coupler and two variometers or other combinations. The detector may be a crystal or a valve. The radio frequency may be any of the three types mentioned in a recent issue, such as choke, resistance and transformer coupled. The reproducer may be telephones or a loud-speaker.

Not all sets have all these features incorporated in them and it is the different types that you must become

familiar with. The ordinary one-valve set consists of a collecting agency, tuner, detector and reproducer. Neither radio nor audio frequency amplification is employed. If greater range is desired in a one-valve set it is the custom to add radio frequency amplification to it. This is placed between the two and four blocks in the drawing. If the range

"threshold" value and if the energy is below that value, the energy will not affect it and you will not hear those radio signals. It is with the use of several stages of radio frequency amplification that these feeble signals are built up and made strong enough to actuate the detector.

If a signal can be heard in the telephones but it is rather weak to be

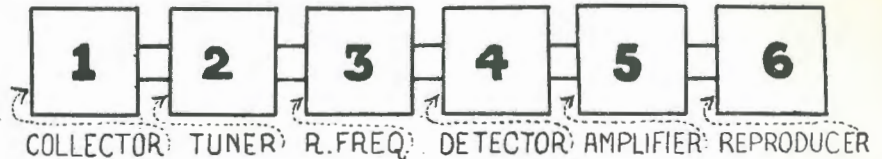

is satisfactory but greater volume is desired, it is necessary to add audio frequency amplification and this is done between the detector and the reproducer, in block.

The reason a one-valve set will do all the things a multi-valve set will is because a detector requires a certain amount of radio energy to actuate it. This is known as the

understood, it may be brought up in volume by the use of audio frequency amplification.

If you can amplify audio and radio frequency currents independently, why not together? You can, as the reflex circuits attest. This is accomplished by the two frequencies being so far apart that they do not interfere with each other.

## Columbia Radio Batteries Are the Best

COLUMBIA Radio Batteries have proven to be the best batteries for radio receiving sets that money can buy. They are made in different styles suitable for every radio equipment and will give more satisfaction than any other make.

### Columbia Dry Cell "A"

COLUMBIA Dry Cell "A" Batteries for vacuum tubes of low amperage are made especially for this work. They will withstand the slow steady drain required and give satisfactory results for a much longer period of time than any other similar type of battery.

### Columbia Storage "A"

For vacuum tubes of one-half ampere or over, the COLUMBIA "A" Storage Battery is ideal. It is shipped dry and charged and filled when sold, thus assuring a fresh, powerful battery. It is tightly sealed and contained in an attractive mahogany finished box with handles.

### Columbia "B"

COLUMBIA "B" Batteries are made in 22½ and 45-volt sizes. They are equipped with Fahnestock Spring Clip Connectors to insure easy, secure connections. They are thoroughly insulated and waterproofed. They are portable, powerful and long lasting.

### Columbia "Three"

COLUMBIA "Three" Batteries are designed so that under certain conditions they can be used as an "A," "B" or "C" Battery. They are made of extra large sized cells, and are used as an "A" Battery for light, portable sets using UV-199 tubes; as a "B" Battery for obtaining additional plate voltage; as a "C" Battery for grid biasing.

*COLUMBIA Radio Batteries for Every Radio Requirement*

**NATIONAL CARBON COMPANY, Inc.**

30 EAST 42nd STREET, NEW YORK, N. Y., U. S. A.

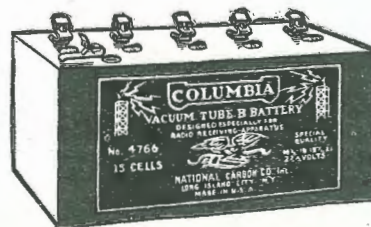



# Queries Answered



**H. G. B. (Rushworth).** Q.: Using a two-valve receiver (circuit submitted), what is cause of trouble experienced with valves, etc.? A.: Wrong filament connections. Recommend circuit posted you.

**H. M. (Rockdale).** Q.: Would a rectifier in conjunction with a bell-ringing transformer (6 volts) be suitable for filament lighting from A.C. mains? A.: No. You will require a transformer stepping down to about 25 volts. An article on the construction of special transformers for this purpose appeared in *Radio*, No. 15.

**C. F. H. (Barcaldine).** Q.: Using a four-valve set, what is cause of receiver suddenly going "dead" and signals then gradually becoming audible? A.: Make sure both A and B batteries are maintaining constant voltage, otherwise it would appear the cause of your trouble is in the grid leak or condenser. Use a variable leak or alter the value of the fixed. You do not state which you are using. The addition of a grid bias battery, if you are not using one, would make an improvement.

**G. M. H. (Singleton).** Q.: What size coils would be required to receive 2FC, using circuits shown in Figs. 1, 3 and 4, *Radio*, No. 39? A.: Fig. 1: Coils should be 150, 200 and 100. Fig. 3: 150, 200, and coils C and D, approximately 200 each. Fig. 4: 150, 200 and 100. Q.: Would two .001 condensers be satisfactory instead of those specified? A.: Yes, one for the aerial circuit, but would be too large for tuning the other coils. Using this condenser in the primary you will probably only need a 100-turn coil. As sizes of coils given depend upon the size of aerial and condensers used, the best method is to obtain additional coils slightly smaller and larger than those specified and select suitable coils for the desired wave-length. Q.: Would an ordinary medical induction coil with iron core do in circuit as per Fig. 4? A.: No. Q.: What B battery voltage does a Cossar valve require? A.: We do not know. Q.: Would you recommend Fig. 4 for this district? A.: Yes.

**M. B. (Leichhardt).** Q.: Can you recommend a circuit using two honeycomb coils? Using the P1 circuit, considerable interference has been experienced from 2BL and amateur stations. A.: As numerous reports have been received of excellent results with this circuit, you are evidently using the wrong size coils or have not

wired up your set according to diagram. Use the additional condenser shown on page 430 *Radio*, No. 42.

**S. J. G. R. (Bondi).** Q.: Can you give me any information regarding the Armstrong Super-regenerative receivers, particularly that one utilising one valve as radio frequency amplifier, oscillator and detector? A.: Obtain a copy of "Vacuum Tubes" by Bucher, which deals with this subject, or "The Armstrong Regenerative Receiver" by Eltz.

## READERS, PLEASE NOTE!

**QUERY** letters which are accompanied by our coupon and comply with the following directions will receive first preference.

**MAKE** your letter as brief as possible and write your questions one underneath the other. All letters must be signed in full, together with the address of the sender. For publication, the writer's initials will be used or a nom-de-plume, if desired, but on no account will any consideration be given to anonymous communications.

**IF** requested, answers will be forwarded by post, providing the letter of enquiry contains a stamped, addressed envelope and the coupon to be found elsewhere in this issue.

**IT SHOULD BE NOTED THAT IT IS IMPOSSIBLE FOR US TO ANSWER QUESTIONS REGARDING THE APPROXIMATE RANGE OF EXPERIMENTERS' SETS.**

**G. M. H. (Hornsby).** Q.: What size honeycomb coils are required for 2BL and 2FC, using a .001 condenser in the primary circuit and a .0005 condenser in the secondary? A.: See previous issues.

**"Fiddle" (Mt. Gambier).** Q.: What are the most efficient dull emitter valves for detecting and amplifying? A.: Use standard English or American valves, such as Marconi, DE3, DER, WD12 or UV199. Be particularly careful to use the correct filament and plate voltage as specified by the makers.

**P. B. (Launceston).** Q.: Please send me circuit of a single valve transmitter for wave-length of 75 to 100 metres, together with size of coils and values of condensers. A.: Unless you already have a transmitting license, suggest you obtain this before going to the expense of installing your transmitter. All applicants for this have to pass a professional examination. In any case, it is hardly likely you will be allowed to transmit on the wave-lengths you specify.

**E. C. (Petersham).** Q.: How can howling be eliminated when using a three-valve set employing detector and two stages of audio frequency, using a WD11 and C301A as amplifiers? A.: There are many causes of howling, such as placing the transformers too close together, too large a reaction coil and capacity effects between the connections. Re-wire your set, making leads as short as possible, particularly high tension connections. Possibly the ratio of your transformers is too high.

**A. A. W. (Wallsend).** Q.: Can you suggest any improvement, other than the various positions tried, for an aerial to overcome induction from power mains (sketch submitted)? A.: Use a counterpoise with Aerial "A." Try placing a shield on the back of your panel as described in *Radio*, No. 43.

**P. A. S. (Hunter's Hill).** Q.: Using a crystal set in Macquarie Street, Sydney, can you advise a simple method of cutting out interference from 2BL when receiving 2FC? A.: Use coupled aerial circuit with condensers in both primary and secondary. Failing this, use the wave-trap described on page 424, *Radio*, No. 42.

**R. A. S. (St. Albans, Vic.).** Q.: Can you give me circuit diagram of a two or three valve reflex to bring in loud signals from 2FC, capable of operating a small loud-speaker and simple to adjust? A.: Reflex circuits require very fine adjustment. Use either the P1 with two stages of audio or a straight-out radio, detector and audio.

**A. E. S. (Northbridge).** Q.: How many turns and what gauge of wire is required for a wave-trap to tune out 2FC when receiving 3LO. Will this interfere with the tuning? A.: Wind 12 turns of No. 18 D.C.C. over a 150-turn honeycomb coil, preferably unmounted. This will make no difference with the tuning of your receiver.

## WIRELESS OPERATORS

**I**N the near future Wireless Operators will be required for ships trading to all parts of the World.

There is only one School in Australia where a Student can receive sound instruction in Wireless Telegraphy, and for the benefit of our readers a few of the advantages offered by this School are detailed.

1. The Instructors are all highly qualified men, combining 20 years' practical experience on Sea and Land
2. The School's equipment is of the very latest, and includes complete commercial installations.
3. Priority of appointment to the Students of the School is given in all vacancies occurring on board ships of the Australasian Mercantile Marine.

The time for enrolling is strictly limited, therefore write \_\_\_\_\_ without delay to the \_\_\_\_\_

MARCONI SCHOOL OF WIRELESS  
97 CLARENCE STREET  
SYDNEY

44 MARKET STREET  
MELBOURNE

Your second query is not quite clear. Would advise you, however, not to interfere with your "Homcharger."

N. B. (Artarmon). Q.: Can an experimental receiving license be altered to include transmission, and what are the qualifications necessary to obtain same? A.: You will have to pass a special examination before being granted a transmitting license. Suggest you communicate with the local radio inspector.

W. B. (Brisbane). Q.: Is three-valve receiver (circuit submitted) more efficient than the P1, using the detector only? A.: More selective but not more efficient. Q.: Can you supply a circuit for a five-valve receiver employing two stages of radio, detector and two stages of audio, using two UV1714 radio transformers and two UV199 valves? A.: Circuit posted. Would advise you, however, to see the transformers are of the correct ratio. Q.: In the circuit of the P1 with two stages of audio, no grid leak is shown; can this be used? A.: Yes, preferably variable. Q.: What is meant by the wave-length of the aerial? A.: Every aerial has a fundamental wave-length governed by its length and height.

E. S. (Melbourne). Q.: Can you advise how to improve reception using a home-made crystal set? A.: Use one of the circuits published in *Radio*, No. 34, preferably No. 5 for receiving 3LO. Q.: Can A.C. be used for filament lighting? A.: Yes, see *Radio*, No. 41.

G. W. A. (Gilgandra). Q.: Can you give me further information regarding a frame aerial for reception during the static season? A.: See article by Mr. Maclurcan in *Radio*, No. 9. Congratulations on your consistent reception of KGO.

R. C. (North Hobart). Q.: What size coils are required for receiving 6WF, N.Z. stations and KGO? A.: 6WF: primary, 150; secondary, 250; reaction, 100. The size of the primary will depend upon the size of your aerial. As most of the N.Z. stations transmit on a low band of wave-lengths, the best method would be to obtain a range of coils from 25 to 75 turns and select suitable ones for the particular station you desire to receive. For call signs, wave-lengths, etc., of N.Z. amateur transmitting stations see *Radio*, Nos. 35 and 36. For KGO, use primary, 35; secondary, 75, and reaction 50. This station transmits on 312 metres, the best times to listen are between 6 and 7 p.m. Sunday, Tuesday, Wednesday and Friday. Q.: Is it possible for a four-valve set to pick up England? A.: Yes, spark or C.W. stations, also the broadcasting station at Chelmsford, using 15 Kw. and transmitting on a wave-length of 1600 metres. For the latter you would require very selective tuning to eliminate interference from Dutch and other stations using this wave-length.

JV. H. R. (Randwick). Q.: Using the P1 with two stages of audio, what is cause of difficulty in tuning in 2FC, using coils specified? A.: You are evidently using

your aerial condenser in series. Use this condenser in conjunction with a series-parallel switch. Q.: Could a UV1714 radio transformer be added to above set and would this increase range? A.: Yes, see circuit published in *Radio*, No. 44.

A. L. H. (Woollahra). Q.: Can you advise me who the following stations are: PCG, PKX, and FFQ? A.: PCG is Land station, Koetwijk-Sambeek; PKX is Malabar. We have no record of FFQ.

M. L. W. (Croydon Park). Q.: Could the voltage of an accumulator be stepped up and the resulting voltage used as plate supply, either for transmitting or receiving? A.: Yes, for transmitting but not for receiving. You will require accumulators with a high ampere hour capacity. Q.: If used for transmitting would this give clearer signals than using generator or rectified A.C.? A.: Yes, but the voltage would not be as constant. Q.: What is a cycle? A.: Frequency of A.C. current is expressed in cycles per second. Two complete consecutive alternations in opposite direction constitute one cycle. Q.: Can you explain reception of 2FC on a crystal set with only earth connection? A.: Your coil or coils would act as an aerial and bring in faint signals from stations transmitting within the minimum and maximum wave-range of the coils. Q.: Which would be the most satisfactory coils, using the P1 circuit, honeycomb or giblin-remler? A.: Either, the size of coils specified would differ when using the latter.

E. W. H. (Singleton). Q.: Why do the British broadcasting stations transmit on a low wave-length? A.: Owing to the large number of commercial and Naval stations operating on the higher wave-lengths. Q.: Can you recommend a few circuits comprising one stage radio and detector? A.: Obtain a copy of "The Amateur's Book of Wireless Circuits" by Haynes. Q.: What is the advantage of a grid bias battery? A.: See "The Use of a C Battery" in *Radio*, No. 41.

E. P. D. (Avondale). Q.: Which would give better results air spaced, Polar or Dubiller condensers? A.: Either would be satisfactory but would depend upon the circuit used. Q.: Using the P1, would it be an advantage to add a variable condenser in the plate circuit? A.: Yes, giving finer tuning. Q.: In circuit of the P1, with two stages of audio should not the A and B batteries be joined? A.: Yes, connect the negative of the B to the positive of the A. Q.: How are "Cockaday" coils wound? A.: Cockaday coils are bank wound with No. 18 double, or single, cotton-covered wire. Q.: Would one stage radio, detector and two audio give better results than detector and three audio? A.: Yes, for DX work.

L. W. (Parramatta). Q.: What value grid leak is necessary, using the three-valve circuit published in *Radio*, No. 40? A.: About two megohms. Q.: Would a 3-1 audio transformer be suitable in the second stage using above circuit? A.: Yes.

Q.: Are the rotor or fixed vanes connected to aerial? A.: Connect the fixed vanes to the high potential end of the circuit; this will overcome hand-capacity effects.

R. M. C. ("Ovalau"). Q.: What is the best time to listen for N.Z. broadcasting stations and KGO? A.: For N.Z., any time after 7 p.m., which corresponds to 8.30 p.m. N.Z. time. For KGO, see answer to "R.C." above.

S. C. B. (Hobart). Q.: Which coils are the most efficient for short-wave reception, honeycomb or pancake? A.: Pancake; honeycomb coils, however, are the best for all round reception, as by inter-changing a large band of wavelengths can be covered. Q.: Which is the best insulating material for honeycomb and pancake coils? A.: See "Honeycomb Coils; How to Make and Use Them" in *Radio*, No. 43. Q.: What number of pins are required on a former for making Burndept coils? A.: We do not know.

W. L. M. (Rockhampton). Q.: How can wave-length of a five-valve Neutrodyne set be increased? A.: This is merely a "Freak" circuit, the same results can be obtained on any straight out circuit and the wave-length is not confined to small limits.

L. S. (Surry Hills). Q.: Is an open core, intervalve transformer quieter in operation and freer from distortion than the usual closed core type? A.: Quality may be improved at the expense of amplification either by shunting the secondary winding with a resistance between 0.5 and 1.5 megohms, or shunting the primary with a fixed condenser, the value of which will be found by experiment, or, providing an air gap in the iron core the right spacing of which can also be found by experiment. An article on the construction of inter-valve transformers appeared in *Radio*, No. 19.

A. T. B. (Malvern). Q.: Would a Skinderviken Microphone button added to a crystal set amplify the received signals? A.: We do not know.

G. H. V. (Leichhardt). Q.: Using a vario-coupler crystal receiver, why are signals from 2FC faint, although satisfactory signals can be received from 2BL? A.: Variocoupler in conjunction with the .0005 condenser is not large enough to tune to 1100 metres. Use a larger aerial tuning condenser or replace the vario with honeycomb coils. Q.: Which is the rotor of a variable condenser in the symbol used for same? A.: There is no special indication for the moving or fixed plates, the former, however, are connected on the earth or low potential side of the circuit to overcome hand capacity effects. Q.: What is cause of unsatisfactory results using crystal valve circuit (submitted)? A.: Probably the valve or transmitter is at fault; you do not state the type of the latter. Use circuit as per Fig. 4, *Radio*, No. 39.



# Thermionic Valve

and its Development in  
RADIO TELEGRAPHY  
AND TELEPHONY

by

J. A. Fleming, M.A., D.Sc.,  
F.R.S.

438 Pages. 280 Diagrams.

Price, 18/- nett.

Postage 6d.

Professor Fleming needs no introduction. His reputation is world-wide, and this new edition of his work brings the first edition right up to date. A tremendous amount of new information has been incorporated, which makes it a much more bulky volume and decidedly more exhaustive than previously. Everyone taking a serious interest in wireless would be well advised to include this in his library, as it is difficult to over-estimate its value and importance to keen experimenters.

### CHAPTER HEADINGS.

SCIENTIFIC PRINCIPLES, Types of Electric Waves, Origin of Electrons Emitted from Hot Metals — THE FLEMING RECTIFYING VALVE, Various Types, Modes of Use and application — THREE AND FOUR ELECTRODE VALVES, Their Evolution, Mode of Operation and Use — THE THEORY OF THE THREE-ELECTRODE VALVE—THERMIONIC VALVE CONSTRUCTION; The Problem of Valve Manufacture and Details of Construction — THE THERMIONIC VALVE AS A GENERATOR OF OSCILLATIONS — THERMIONIC VALVES AS AMPLIFIERS AND DETECTORS—THERMIONIC VALVE TESTING — FLEMING REPEATERS AND RELAYS, Its Problems and Requirements — THERMIONIC VALVE PLANT, Advantages of Continuous Wave as against Spark Systems.

## THE WIRELESS PRESS

97 Clarence Street, Sydney.  
44 Market Street, Melbourne.  
Australasian Chambers, Wellington,  
N.Z.



### NOVEMBER.

Mr. A. S. Middleton signed off s.s. *Tarcoola*, at Sydney, 7th, and relieved Mr. A. V. Zoppi on s.s. *Aldinga* at Sydney, same date.  
Mr. G. Vincent signed off s.s. *Ellaroo* at Melbourne, 6th.  
Mr. G. W. Rowland signed off s.s. *Moorabool* at Geelong, 3rd, and relieved Mr. E. I. Hyde on s.s. *Narana* at Melbourne, 5th.  
Mr. E. I. Hyde signed on s.s. *Moorabool* at Geelong, 3rd.  
Mr. R. T. Murray signed off s.s. *Melusia* at Sydney, 7th.  
Mr. A. V. Zoppi signed on s.s. *Melusia* at Sydney, 11th.  
Mr. W. R. Baird signed off s.s. *Moreton Bay* as 2nd operator at Sydney, 11th, and signed on s.s. *Arafura* as 2nd operator, on the same date.  
Mr. W. L. Myers signed on s.s. *Arafura* as 3rd operator at Sydney, 11th.  
Mr. L. E. Ashby signed off s.s. *Yarra* at Newcastle, 12th.  
Messrs. A. E. Shepherd and J. Ridler signed off s.s. *Moreton Bay* as senior and 3rd operators respectively, at Sydney, 12th.  
Messrs. N. W. Leeder, L. G. Curnock and P. B. Holdsworth signed off s.s. *Ferndale* as senior and 3rd operators respectively, at Sydney, 14th.  
Mr. G. Vincent relieved Mr. R. P. Ginders on s.s. *Moeraki* at Melbourne, 10th.

## Helpful Hints

IF you use WD valves, it is a good idea to mount the tube sockets on soft rubber sponge.

IF you have a long aerial, you can pick up stations within a radius of 50 miles, and some nights you will stretch it to two or three hundred.

YOUR aerial does not have to be horizontal to effect good receiving.

### TRADE ANNOUNCEMENTS.

MESSRS. L. P. R. BEAN & CO., LTD., of 228 Castlereagh Street, have been appointed exclusive Australian representatives for the well-known, high-grade Jewell instruments made by the Jewell Electrical Instrument Co. of Chicago. Goods include A and B battery testers, radio frequency meters, plate milliameters, wave meters, special valve characteristic test set and grid leak meters. All modern receiving sets are being equipped with quality battery instruments of the panel mounting type. The trade is invited to get in touch with Messrs. Bean and Co. for full particulars.

We are Sole Agents for  
**"ASHCOY"**

Brand Best British Polished

## Ebonite Panels

FOR RADIO WORK.

Each packed in a sealed envelope. Stocked in all the standard sizes for crystal and valve sets. Edges ground true to size.

ASK YOUR RADIO DEALER

Full Stocks of British Ebonite Sheets, Rods and Tubes.

WHOLESALE ONLY.

**A. S. HARRISON & COMPANY,**

'Phone: 5-7 Barrack Street, P.O. Box  
B 4574. SYDNEY. 2591.

## HUGHES & CO.

HIGH-CLASS

CIVIL and NAVAL TAILORS

Our civil Suits are perfection in STYLE FIT, DURABILITY and PRICE. TAILOR-MADE on the premises under our own supervision.

OUR NAVAL UNIFORMS and GOLD LACE work speak for themselves. CAPS, LACE, BADGES, UNIFORM BUTTONS always in stock.

ONE Quality only — THE BEST.

70-72 Erskine Street, SYDNEY

'PHONE: City 77.

## FOR SALE,

### SECOND-HAND WIRELESS APPARATUS.

Variable Condensers, Table Type, .001 or .0005 .....	17/8
Receiver Cabinets, Polished Maple ..	11/8
Fillament Rheostats, 6 ohms .....	5/-
Polished Bakelite Panels, drilled 12 x 8 1/2 inches .....	8/8
Vario Coupler with Knob and Dial ..	15/-
Audio Frequency Transformers, open core type; Ratio 3 to 1 .....	10/-
Fixed Condensers, .001 or .00015 .....	1/-
Honeycomb Coils, 75 and 115 turns, 1/2-inch wide .....	9d.
Calibrated Dials, less knobs, .0 to 10 ..	8d.
Polished Bakelite Panels, 12 x 8 1/2 in. ..	8/-
Telephone Jack and Plug .....	3/8

Also quantity of other Wireless Apparatus.

Open for Inspection at 218 Kent Street, at 4 p.m. week days; Saturday mornings, 9 till noon

Address all communications to  
Department "S," 218 Kent Street.

**AMALGAMATED WIRELESS (AUST.), LTD., SYDNEY.**

"Static" (Trundle). Q.: What is cause of poor signals from 2FC using a five-valve set? A.: Submitted particulars too meagre. If you are using variocouplers for tuning, it is possible you are unable to get up to the higher wave-lengths. Earth wire appears satisfactory. In any case, if you are troubled with atmospherics, using the five-valve will increase these considerably more than the signals and it will be practically useless trying to receive, if static is very bad, using an outdoor aerial.

"Mouse Whisker" (Pine Lodge South). Q.: In which number of *Radio* did the P1 circuit appear? A.: Nos. 36 and 38, copies of which can be obtained from this office. Q.: What constitutes a turn on a honeycomb coil? A.: See "Honeycomb Coils" in *Radio*, No. 43. Q.: Will a Perikon detector do for a reflex single valve set? A.: Yes; suggest, however, you use either "QSA," "Sacrystal," or "Galena"; these will give you better results. Q.: In what position

it is possible, however, experiments were being carried out on five Kw.

E. P. W. (Sydney). Q.: What is actual height of aerial 65ft. from the ground running 15ft. above a large roof? A.: The effective height of your aerial is 15ft., the roof acting as a counterpoise. Either alter the position of your aerial or increase the height of your masts; this will give you greater efficiency. Q.: Would it make any appreciable difference if the leads are not quite the same length? A.: No, providing they are well insulated from any intervening objects.

J. J. R. (Mosman). The old theory regarding the direction of the flow of electric currents has not, as you say, been upset. In fact this assumption fits in very well with the electron theory—that a flow of electrons in an electric circuit is opposite to the direction (as unversally defined) of the resulting current. To understand this clearly, suggest you obtain a

A. C. T. (Drummoyne). Q.: Using the P1 circuit, should there be a connection from the filament and the lower end of the coil B? A.: Yes, this was omitted in the pictorial diagram. Q.: Would it be correct to place a switch in the B battery circuit marked in sketch? A.: Yes. Q.: Would a series-parallel switch be an improvement? A.: Yes, this being a quick method of changing your wave-length.

G. R. T. (Stockton). Q.: Can you recommend a four-valve circuit for receiving all Australian broadcasting stations and to tune from 200 to 2,500 metres with simplicity of tuning? A.: Suggest you use one stage radio, detector and two stages of audio frequency amplification, such as the three-valve circuit published in *Radio*, No. 44, embodying the P1 circuit with an extra stage of audio. Some excellent circuits, however, are published in "The Amateur's Book of Wireless Circuits" by Haynes, showing connections of jacks for using one or more valves. Q.: Which would be the most suitable valves? A.: Any standard English or American type, and either those working from dry cells or accumulators. Q.: Would you advise tapped coils, honeycomb coils or variocoupler tuning? A.: For the large range of wave-lengths over which you desire to receive, use honeycomb coils.

R. A. S. (St. Albans, Vic.). Q.: Using the P1 with a stage of audio, what is cause of signals being "blurred"? A.: Possibly the ratio of your transformer is too high. Q.: What proportion of turns is required between aerial, secondary and tickler? A.: See previous issues. Q.: Is a "Kellogg" A.F. Transformer, No. 501A, suitable for broadcast receiving? A.: Yes. Q.: What are correct coils to use for 3LO? A.: Using tuning condensers of .001 mf., primary, 150; secondary, 250, and reaction, 150. You will note in the query you remark that a .0003 anode condenser is used. Q.: What would be the range of a "Kellogg" variometer used as anode tuning coil? A.: Maximum about 900 metres.

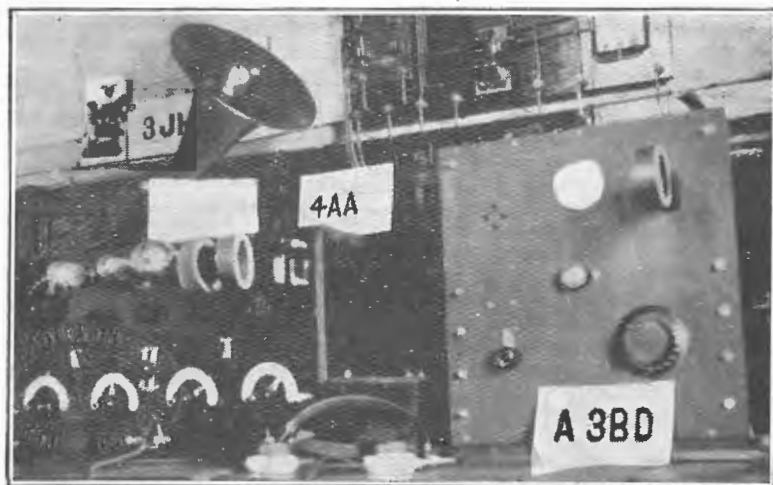

Portion of the station of Mr. T. R. Anthony, of Auburn, N.S.W. Mr. Anthony has heard KGO about 30 times and has a DX list to his credit which shows him to be an experimenter of the very first water.

would you advise aerial to be erected with regard to power mains (sketch submitted)? A.: Preferably at right angles to the mains of the proposed house supply, i.e., East and West. Erect your nearest mast at point A and the other mast East from that, inverted L aerial single wire, otherwise you will be unable to get down to the short wave amateur transmitters, using a double wire 100ft.

E. A. T. (Victoria Park, W.A.). Q.: Using a three-valve tuned anode R.F. amplifier detector and 1LF, etc., what is cause of receiver not oscillating, also "whistling"? A.: Probably transformers are the cause of your trouble. You have not sent sufficient information regarding the apparatus you are using, such as type of valves and transformers. From your report it appears the ratio of your L.F. transformer is too high. Q.: On what power was 2FC transmitting about the middle of July last? A.: About 2 Kw.;

copy of "The Oscillation Valve" by R. D. Bangay.

G. D. (Epping). Q.: Would a Radiotron WD12 valve fit in a UV199 socket? A.: No, the only valves which will fit in this socket are C299's. See "An Adaptor Made from Junk," *Radio*, No. 42.

W. F. R. (Lismore). Q.: Using the special three-valve receiver in *Radio*, No. 40, would two variable condensers (.0005) be satisfactory instead of a .001 and .0003 as specified? A.: Yes, you will probably need to use slightly larger coils than those specified for the various wave-lengths. Q.: Are K and CA3 transformers satisfactory for the above circuit? A.: Yes, a fixed condenser may be used across the primaries for finer adjustment. Q.: What should be the plate voltage? A.: Depends upon the valves used. See previous issues for voltages for both the filament and plate for various valves.

YOU can increase amplification to almost any extent but above two stages it is difficult to control it.

WHEN putting up your aerial, if it must be near wires put yours at right angles to them.

WHEN you buy your set, have the dealer demonstrate it. If it is what he claims it is, he will gladly do it.

ACID from your storage battery will eat holes in almost anything, so be careful.

CLEARER signals are obtained with the detector valve adjusted below maximum signal strength.

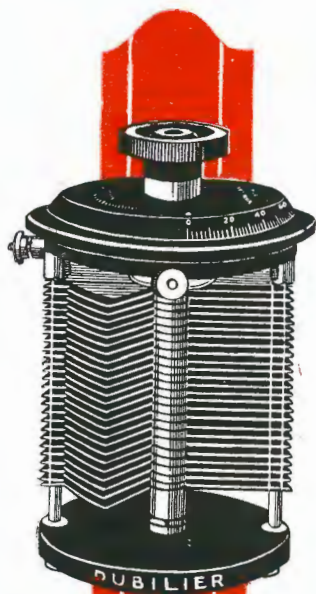

*Dubilier  
Variable Condenser.  
Price, .001 capacity, 35/-.*



*Dubilier Mica  
Condenser, with grid  
leak clips.  
Price, .00025 capacity, 3/6.*



*Dubilier Mica  
Condenser.  
Price, .001 capacity, 4/-.*

*The name "Dubilier"  
stands for leadership in  
Condensers.*

## DUBILIER CONDENSERS

The Radio enthusiast, in these days of highly efficient valve apparatus, is most exacting in his requirements. No condenser will be tolerated unless its internal and leakage losses are an absolute minimum; no condenser finds a place in his receiver unless he is assured that it will remain constant under all conditions.

Amateur experimenters in all parts of the world employ Dubilier British-made condensers in their transmitting and receiving sets. "Dubilier" is specified by the experts because they know that years of research and manufacturing experience stand behind every condenser. You will realise—just as they do—what this means in efficiency.

**"Specify Dubilier."**

**Amalgamated  Wireless**  
*(Australasia) Ltd.*

97 Clarence Street, Sydney  
Collins Street, Melbourne

*Supplied in  
all capacities.*



*I am DINKIE—you'll like me*

I am the mascot of the latest Sterling Loud Speaker—"The little fellow with the Loud voice." My "Dinkie" Loud Speaker will go into the homes of tens of thousands of those who love Radio. It's small in size but big in volume—small in price but big in value. And as to its reproducing powers? Well! whether it is music, song or speech, "Dinkie" gives perfect reproduction, true in tone and ample in volume! The "Dinkie" will be widely advertised, and is destined to become the greatest seller radio has ever known. Costing little more than good headphones, what can stop it?

# STERLING DINKIE Loud Speaker

The Sterling "Dinkie" Loud Speaker is supplied in a Brown tinted finish, complete with flexible cord.

**DIMENSIONS:**

Height over all, 13 in. Diameter of Flare, 7 in.  
Diameter of Base, 4 in.

*Ask your Dealer to Demonstrate.*

**STERLING TELEPHONE & ELECTRIC CO. LTD.**  
Manufacturers of Telephones and Radio Apparatus, etc.  
210-212 TOTTENHAM COURT RD., LONDON, W.1  
ENGLAND.

*Sole Agents for N.S.W. and Queensland:*

**THE LAWRENCE & HANSON  
ELECTRICAL CO., LTD.**  
33, York Street, Wynyard Square,  
SYDNEY.  
And Charlotte Street, Brisbane.

**TO THE TRADE**

The Sterling range of Radio Apparatus covers all that is necessary for perfect Radio reception and reproduction:—Crystal sets; 2, 3 and 4 valve receiving sets; 2 and 3 valve power amplifiers; world famous headphones; various types of loud speakers and every conceivable component. Lists and full particulars on application.



*Here's my  
Loud Speaker*