

# RADIO SCIENCE

Vol. 1.—No. 5.

Registered at the G.P.O., Sydney, for transmission by post as a periodical.

JUNE, 1948

- THE CARAVAN FIVE VIBRATOR RECEIVER
- MULTIPLE TRACK RADAR RANGE-PI. 2
- POST WAR R.A.A.F. WIRELESS RESERVE
- U.H.F. TECHNIQUES—THE KLYSTRON
- NEW FEATURE—TRANS TASMAN DIARY



Price **1/6**



# VALVES AND THEIR APPLICATIONS

By M. G. SCROGGIE, B.Sc., M.I.E.E. (Eng.)

## No. 1: Mullard GAS TRIODE EN31

Of the many applications of "soft" triodes, time base generation has always been the most widely used. The main reason for its popularity in that role is its ability to change suddenly from zero to a heavy current at a low voltage, and thereby to discharge a capacitor so quickly that the flyback is accomplished in a very small fraction of the whole cycle. By contrast, a hard valve requires some amplified triggering device to speed up the discharge, and even then is not such a low-resistance "switch."

The explanation, of course, is that directly any appreciable electron current starts to flow through low-pressure gas the molecules are ionized, or split up into electrons and positive ions, forming an electrically - neutral highly - conducting cloud. It is as if the anode were suddenly brought within a microscopic distance of the cathode. There is, therefore, negligible space charge for the anode voltage to overcome, even when the current is very heavy. The anode-to-cathode voltage is constant at quite a moderate critical value, depending on the kind of gas enclosed. Although the 33 V drop in the EN31 is higher than in a mercury-vapour valve, its characteristics depend much less on temperature.

Since the control grid is smothered by the conducting cloud, it ceases to control, until the discharge ends through lack of voltage to maintain it. Its function is then to determine, by the negative bias applied, the anode voltage needed to re-start the discharge, and hence the amplitude of the time-base voltage. In the EN31, 1 volt of bias is needed for every 35 additional anode volts.

The circuit diagram shows a very simple form of time base generator. It can, of course, be modified to include

one of the usual linearizing devices, but except for precise work the stroke is linear enough if restricted to about 30 or 40 V. R1 controls the speed of charge, and R2 the bias. R3 is to limit the discharge to the rated maximum, 750 mA.  $2 \Omega$  for every HT volt is well on the safe side. R4 is another limiting resistance, to keep the grid current within 1 mA. The total resistance between grid and cathode should be  $0.75M\Omega$  at most; preferably less. Since the bias required for control is only 1-35th of the anode voltage, the heater can be joined to —HT without fear of its voltage to cathode exceeding the rated limits of 0 to —100 V.

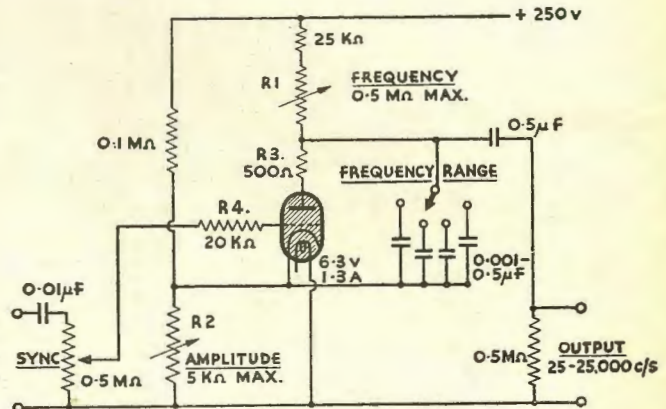

*This is the first of a series written by M. G. Scroggie, B.Sc., M.I.E.E., the well-known English Consulting Radio Engineer. Reprints for schools and technical colleges may be obtained free of charge from the address below. Technical Data Sheets on the EN31 and other valves are also available.*

**MULLARD (AUST.) PTY. LTD.**  
35 CLARENCE ST., SYDNEY  
Distributors in all States

## Illegal Transmitters

Probably the most sensational news during May was the appearance of a secret radio station in Melbourne, operating under the call sign DIG.

This station made its first broadcast earlier in the month by the simple procedure of suddenly jamming one of the Melbourne commercial station's programmes and requesting the listening audience to re-tune their receiver to a stipulated clear wavelength. The nature of the broadcast which followed was of a political theme specially directed towards all ex-servicemen.

Whilst there have been previous illegal broadcasts in this country, by the unauthorised operation of transmitters, this is the first time it has reached the status of an "underground" movement. Ignoring the moral aspect and political viewpoints propounded, however good, bad or necessary they may have been, the seriousness of such an action cannot be over-emphasised. The question at stake merely resolves itself into one of a breach against the Wireless Telegraphy Act, which carries certain penalties for this type of action. It is essential that this Act be enforced impartially otherwise, as will be readily realised, chaos and consternation could possibly result from other illegal broadcasts.

According to some reports it appears certain that the equipment used was similar to that now readily available through many disposal sources. The official view to this indiscriminate sale of radio transmitters without any check on the purchaser, is to be deplored. Whilst undoubtedly many of the sales are made to legitimate amateurs, it is felt that much of the equipment is finding its way into the possession of irresponsible persons, who by their subversive actions may later prove an embarrassment, as well as being an annoyance to the listening public.

Probably the simplest procedure to overcome this serious problem, would be to record or limit the sales of such transmitting equipment, so that in the event of any future emergency arising, the location of much of this equipment should be readily known.

## *In This Issue*

The description of our new receiver—"The Caravan Five" should interest many readers. Although this was designed primarily as a high performance, low current drain receiver for a caravan, it should prove equally popular with all country radio enthusiasts and be an asset in any country home where such features are desired.

A perusal of the circuit will indicate its somewhat unorthodox nature, in that it combines the 1.4v. miniature valves with a standard AC output valve. This combination successfully giving rise to the required low drain as well as providing ample power output for most needs.

Pursuing our policy of providing the reader with a complete radio coverage, this month we present a new feature—Trans-Tasman Diary. This will be a regular monthly bulletin dealing mainly with radio activities in New Zealand, and is a feature which we anticipate will become very popular with both our local and overseas readers.

It is suggested that all New Zealand readers co-operate with our correspondent by providing him with a ready source of interesting news concerning any radio activities in the Dominion.

# KITS! KITS!

## ALL WAVE BATTERY TWO

As featured this issue—complete kit includes all parts, 1T4, 3S4, Batt's etc., 'phones extra.  
(Freight extra) .. . . . £6-19-6

## "MINIVOX" 3 VALVE A.C. KIT

A midget mains kit, uses 6SJ7, 6V6, 6X5. Complete Kit includes Midget Pow.-Trans, Chassis, Valves, Speaker, Cabinet, etc. . . . . £9-2-6  
(Freight extra.)

## "MINIMINOR" 4 VALVE PERSONAL KIT.

A 4-Valve Midget Portable. B/cast Super-Het. Uses 1T4, 1S5, 1R5, 3S4, 3in. Rola, Cad.-plated Chassis. Complete Kit includes all parts, plus beautiful shoulder strap carrying Cabinet . . . . . £12-19-6  
(Freight extra.)

## "MINIMINOR" 4 VALVE A.C. MIDGET MANTEL KIT.

Kit includes EK32, EBF35, 6V6, 6X5, 3in. Rola Midget P./Trans., choke and all parts, plus attractive Cabinet. (Available in Colours.) . . . £13-17-6  
(Freight extra.)

## "THE CARAVAN" 6 VOLT KIT.

A "Super" Receiver, for country or holiday use. Has RF Stage—high output—low battery drain—very sensitive—uses (2)1T4 (1)1R5 (1) 1S5 (1) 6V6, etc. Complete kit, less Spk. and case . . . . . £19-17-6  
(Freight extra.)

## "DUAL WAVE SEVEN" KIT.

Latest Hi-gain Circuit—(2) 6SE7 (1), ECH35, (1), 6SQ7 (1), EL33 (1), 6S57 (1), 5Y3, etc. RF Stage, using Midget 3 Gang. Complete Kit includes all parts, less Case and Speaker. (Speaker for above 37/6. . . £24-11-11  
(Freight extra.)

## KIT BUILDERS.

We will quote you for any kit that you require. Write and forward details kit required. Should you desire, we will for a small additional charge, custom-build, wire, and check your kit for you.  
Radio Kits, Amplifiers, Public Address, Intercommunication systems, Communication Receivers, built, modified, or repaired.

## "FREE TECHNICAL SERVICE."

"HI-FIDELITY 807 P/P AMPLIFIER" A custom-built unit. Uses all high class components. (1) 6SJ7 pre-amplifier, (2) 6SN7 (2), 807 (1), 5U4G—Red Line Transformers and Chokes. A unit for the discriminating Hi-Fidelity Lover. Complete unit, wired, tested, less speaker . . . £32-12-7  
(Freight extra.)

## "FIRST RELEASE" F.N. MIDGET PORTABLE AMPLIFIER

Size only 9in. x 6in. x 5in. Weight 12lb. Full 7½ watt output. Uses 807's—two inputs, Grey or Maroon Crackle Finish Cabinet with Chrome Carrying Handle. Complete unit, wired, tested, etc. Speaker extra. (Freight extra.) £18-7-6

## "COUNTRY MAN'S" "SPECIAL" OFFER.

A special purchase of a manufacturer's discontinued line. Allows us to offer the following "Special." A 5 Valve Vibrator B/cast Chassis, fully wired, tested, and complete with valves and vibrator. But less speaker and case. Originally sold for £38-12-6. Our Special Price to Clear £13-10-0. Few only—So Hurry! (Freight extra.)

## "PERSONAL PORTABLE" "SPECIAL"

Another "Lucky" purchase enables us to offer you this exceptional bargain. But hurry, as stocks will not last. This "Special" is also a manufacturer's discontinued line. A Five Valve, Personal Portable, Foundation Kit, Custom-made, Cadmium-plated Chassis. All Coils, Tuning Condenser, IP's, Special Vernier Dial, Switch Pot, Knobs, and all Hardware. Complete Kit, less Valves and case, assembled ready to wire. Original Price £24-17-6.

OUR PRICE . . . . . 142/-  
Beautiful Coloured Leather Cases for the above. Shoulder strap. Built in Aerial, 42/-. (Freight extra.)

# RADIO PARTS

Midget Q Plus, AE-RF Coils 6/11  
Midget Q Plus OSC Coils . . . 4/9  
Midget Q Plus 1F Transformers 13/9  
Midget Q Plus D/W Coil Kit 44/-  
Midget Q Plus Loop Aerials . . 6/11  
Midget Q Plus Flush Knobs, Colours

Midget FN Reinartz Coil . . . 1/3  
Midget FN 150/150V 30MA P/Trans. 20/7

Midget Filter Chokes . . . . . 8/9  
Midget 8MFD Electrolytics . . . 3/9  
Midget Single Gang Cond's . . . 12/6  
Midget Two Gang Cond's . . . 19/3  
Midget Three Gang Cond's . . . 25/3  
Midget Trimmers . . . . . 1/1  
Midget Off-On Switches . . . . . 2/9  
Midget DP47 Dials with Knobs 7/11

Minivox Chassis . . . . . 6/6  
Minimior Port Chassis . . . 14/6  
Minimior Mantel Chassis . . 11/6  
Minivox Cabinet in Colours . . 23/6  
Minimior Mantel Cabinet . . . 25/6  
Minimior Port. Cabinet in Colours 28/10

Volume Controls, any size . . . 3/9  
.5 and 1m. Switch Pots . . . 7/6  
6.3V Pilot Lamps—U.S.A. . . . 1/3  
½ Watt Insulated Resistors . . 9d.  
1 Watt Insulated Resistors . . 1/9  
3W W/W Resistors . . . . . 1/9  
Amphenol Valve Sockets, 4, 5, 6, 7, 8 p . . . . . 1/-  
Rubber Grommets . . . . . 2d.  
Resin Core Solder (Roll) . . . 1/-  
Hook-Up Wire, any colour 2d yard  
New 2000 Ohm Phones . . . . . 27/6

## "JUMBO" SURPRISE PARCELS.

We urgently require space in our factory for manufacturing purposes, and so must clear out surplus stocks, etc. We have boxed these surplus parts into 8lb. lots. They include Resistors, Condensers, Sockets, Terminals, Brkts., Plugs, Hardware, etc. We must have the space, so out they go at 15/- each (Freight Extra Please.)

## TUBES.

Thousands of Tubes, if not listed here write us for Price.

"SPECIALS"  
Type 27 .. 6/6  
Type 1E7 .. 7/-  
902 C.R.T. 35/-  
5BP1 CRT 37/6  
(Post extra.)

1A3 19/9  
1A7 22/10  
1D8GT 29/10  
1G4 19/3  
1G6 20/9  
1H4 17/10  
1J6 18/10  
1L4 20/3  
1P5 22/4  
1N5 22/4  
1Q5 22/10  
1S5 20/6  
1T4 20/6  
2X2 12/9  
3S4 20/6  
3V4 20/6  
5U4 19/3  
5V4 19/10  
5Y3 14/7  
9001 21/-  
9002 21/-  
9003 21/-  
9004 5/-  
9006 5/-  
VR105 20/-  
VR150 21/-  
5BP1 37/6  
6AC7 21/-  
6AK5 26/-  
6AG5 26/-  
6AG7 27/-  
6AUS 21/10  
6B6 18/4  
6BE6 21/10  
6BA6 21/10  
6C4 26/-  
6C5 19/3  
6F6 17/10  
6F8 21/3  
6G6 20/9  
6H6 19/3  
6J5 16/9  
6J6 26/-  
6K7 20/4  
6J7 18/4  
6K8 19/10  
6L6 21/-  
6L7 21/6  
6N7 21/7  
6R7 20/9  
6Q7 19/9  
6SA7 19/4  
6SH7 19/6  
6SJ7 18/4  
6SK7 18/4  
6SL7 21/6  
6SN7 23/6  
6SS7 18/9  
6SQ7 18/4  
6V6 18/10  
6X5 20/10  
7C7 17/3  
12SF7 20/-  
12SK7 19/3  
12SQ7 18/4  
14C5 17/3  
14C7 17/3  
14S7 17/3  
14W7 17/3  
32L7 25/-  
80 14/7  
807 16/6  
813 16/6  
837 25/-

## "HI-FIDELITY EQUIPMENT"

Red Line, Power Trans., 807 P/P £3/15/-  
500/500 at 175MA-5V8A-6.3V2A-6-3V2A  
Red Line Filter Choke—12h—175MA 33/6  
Red Line Smoothing Choke—25h—60MA . . . . . 29/6  
Red Line Output Trans.—10,000 ohm PRI-807 P/P—SEC. as required . . . . . 122/6

"ACOS" GP10 X'TAL PICK-UP Pressure only 1¼ ozs.—output 1.7 volts.  
Special Non-Shock Mounting—complete . . . . . 48/6  
"Acos" GP9—Magnetic Plug, output 36 volts . . . . . 42/1  
"Acos" GP10 Xtal Replacement unbreakable Cartridges . . . 22/-  
Quotes Supplied on ANY Equipment not listed.

## "AMERICAN MADE GENEMOTORS"

A Real Bargain.  
Input 28V—Output 225V at 60 MA 115/-  
Input 28V—Output 590V at 150 MA 155/-  
(Rail Freight only.) (Freight extra.)

## "6 VOLT—VIBRATOR POWER PACKS"

Input 6 volt—Output 228 V at 60 MA, tapped 228—180—150—120—and 12 volts—fully filtered—ideal for country use—strong steel case. 25lb. weight. A Bargain . . 85/-  
(Rail Freight only.) (Freight extra.)

## "INSTRUMENT CASES"

New, Welded Steel Cases, Grey Crackle Finish—9in. x 6in. x 5in.—ideal for VTVM's, Sigtracers—Generators, etc. . . . . 22/6  
(Freight extra.)

## "INSTRUMENT PROBES"

Highly Polished Metal Probes, with Poly Tip and Base, for VTVM's, S/Tracers, S/Generators—takes Button Base Type Valves . . 8/6  
(Post extra.)  
As above, fitted with 1T4 or 9001, and Res. capacity, Network, Shielded Flexible Cable, etc. . . . . 42/6  
(Post extra.)

## FEW ONLY—IN21—IN24 GENERAL ELECTRIC CRYSTAL DIODES.

Price on application.  
300 Ohm Twin Feeder Transmission Line . . . . . 1/2 yard

Midget UHF Valve Sockets (Button) 4/9

EF50 Mica Filled Sockets . . . 5/4

959—955 Acorn Ceramic Sockets 5/9

813 Type Valve Sockets, Ceramic 9/8  
Heavy Duty 120 Watt Resistors—6000 3/-; — 15,000 3/6

Flexible ¼in. x 4in. Couplings 1/3

Imfd. 4000 V Can Condensers . . 2/

Acos Midget X'tal Mikes, 1 11/16in. x 5/16in. . . . . 29/-

"English" Power Transformers, heavy duty—400/400 V at 250 MA—4 V at 5 amp. . . . . 45/-  
(Rail Freight only—extra.)

# F. N. Radio & Electronic Co.

265 MILITARY RD., 'Phone: CREMORNE, N.S.W. XM7063

SAME DAY MAIL ORDER SERVICE — CALL, WRITE or PHONE — ALL ENQUIRIES ANSWERED PROMPTLY.  
"F.N. RADIO has the stocks" — "F.N. RADIO can help you" — "F.N. RADIO knows how"



## RADAR AIDS TO NAVIGATION

# MULTIPLE TRACK RADAR RANGE

By JOHN G. DOWNES, B.Sc., A.M.I.E.E.

In this second article the nature of "hyperbolic navigation," which forms the basis of the M.T.R. system is discussed in some detail.

Systems of navigation such as *Gee*, *Loran* and *Decca*, names which have become familiar during and since the recent war are based on the hyperbolic principle, and it will be well to devote a little time to studying it, since it is of prime importance.

It was described in the first part of this article how track guidance systems which are based on the comparison of *signal intensities* are inherently subject to error as a result of reflections or other causes changing the relative intensities. It is natural, therefore, to look for some other characteristic of the original as a basis of comparison, and the logical choice is the *relative phase* of two C.W. signals received from a station or stations, or the corresponding thing in the case of pulse signals, namely, the *relative time of arrival* of two signals.

Suppose then that we decide to use this relative phase or time of arrival of two signals to define some kind of track, the question arises: "What form of track is obtained?" (It must be noted, by the way, that if we are to make use of the difference in phase or arrival time of two signals, it will be necessary to keep the phases or times of

transmission of the two signals at the station(s) in some constant relation, in other words, the transmitted signals must be *synchronized*. This corresponds to the necessity for keeping the aerial currents equal in an equi-signal radio range.)

The most straight forward way of making use of the relative time of arrival of two pulses is to fly the aircraft so that the time-difference remains constant at some arbitrarily chosen value. What path does the aircraft then follow? To answer this we recall that the time of travel of each pulse is proportional to the distance of the aircraft from the corresponding station, so that what we are doing in effect is to cause the aircraft to fly so that there is a *constant difference* in its distance from the two stations. It is the especial property of that curve known as the hyperbola that at any point on it the distances to the two foci of the hyperbola differ by a constant amount. Our aircraft is therefore flying a hyperbolic track, and each of the two ground stations is at a focus of the hyperbola.

### Hyperbola Construction.

It is simple and interesting to construct a hyperbola on a sheet of paper, using the basic property we have just mentioned. Such a construction gives us a clearer insight of the basic idea on which hyperbolic navigation systems depend. On a sheet of paper mark two points some convenient distance apart, say 2 inches. These represent our two stations. Next decide on a value for the difference, which it will be recalled is to be constant, between the distances to the two stations from any point on the track;  $1\frac{1}{2}$  inches will be a suitable value for a start.

Choose a number of values for the distance from one station (which we shall call A), for example, 2, 3, 4 inches; then the *corresponding* distances from Station B will be  $(2-1\frac{1}{2})$  inches and so on, i.e.,  $\frac{1}{2}$ ,  $1\frac{1}{2}$ ,  $2\frac{1}{2}$  inches. To get the first points on our curve draw part of a circle of radius 2 inches around A, and find where this intersects a circle of  $\frac{1}{2}$  inch radius around B; mark the points. Repeat the

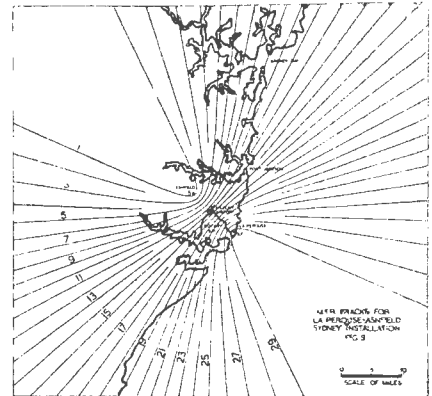

A typical MTR track system. The hyperbolas become straight radial lines a short distance from the stations.

process with circles of 3 and  $\frac{1}{2}$  inch radius respectively, and so on, in each case marking the points of intersection. When sufficient points have been taken, they will, when joined up, produce a smooth hyperbolic curve. The process is illustrated in Figure 1.

If we retain the "station" spacing of 2 inches but alter our constant difference—difference, say to  $1\frac{1}{4}$  or  $1\frac{3}{4}$  inches and repeat the construction, a new curve will be formed. This is equivalent to flying the aircraft so that the difference in the arrival time of the two pulses has some new but still constant value. A whole series of curves can be obtained in this way and such a series is known as a track system. It is the result of maintaining a fixed station spacing and defining arbitrarily a number of values for the difference in pulse arrival time. In Figure 2 is illustrated a typical hyperbolic track system.

The usual procedure in operating a hyperbolic navigation system is to select a series of suitable values for the difference in pulse arrival time and to draw the corresponding hyperbolic tracks superimposed on a conventional map. The time-differences may be marked on the respective tracks, or more usually a dis-

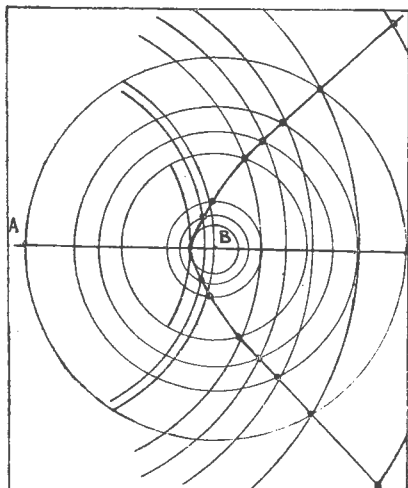

Derivation of hyperbola from intersecting circles.

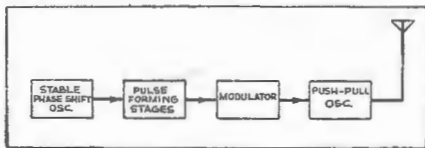

Block schematic diagram of MTR master station.

tinguishing number is allotted to each track. In the aircraft the pilot or navigator measures the time-difference between the received pulses (he may not be aware that he is doing this; the equipment may do it automatically and provide the answer as a track number) and by reference to his map find on which track he is. Alternatively he may, using his map, select a track which coincides with his desired course and then fly the aircraft so as to maintain the appropriate constant time-difference (again he may be unaware of the actual process, and merely maintain a constant track-number reading).

Track numbers can be seen in Figure 2, and in the illustration of a *Gee* network in the first part of this article.

In some hyperbolic navigational systems it is desired to give the aircraft complete information as to its *position*; *Gee* is an example of such a system. Now in a single track system the pilot of the aircraft is not aware of his position, but only that he is on or adjacent to some particular track. To provide an indi-

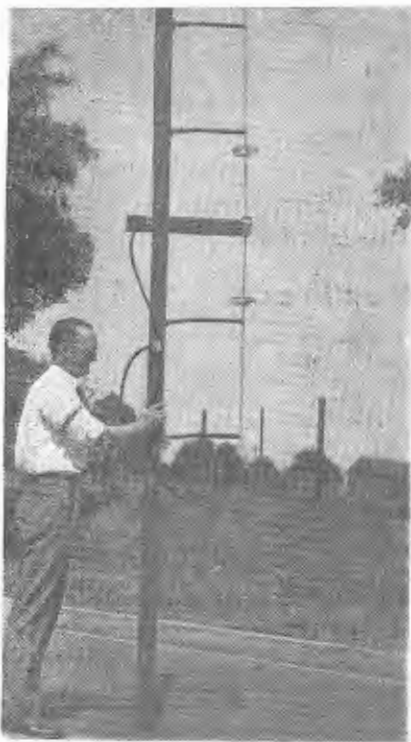

The type of transmitting aerial used at the MTR ground station, consisting of three half wave elements.

cation of position a second complete track system, intersecting the first, is sometimes used. The resulting system is known as a lattice. By determining which track the aircraft is on in each system its position can be fixed. The use of lattices is mentioned in passing, but in the Multiple Track Range a single track system only is used, since in this case it is desired to define tracks only, and not to fix positions.

A mere glance at the track system of Figure 2 is sufficient to see a very interesting and important feature of a set of hyperbolae, namely, that the greater part of each curve is very nearly a straight line. If we draw around the centre of the base line (the line joining the two stations) a circle of radius about twice the base line length, then for most practical purposes the tracks outside this circle may be regarded as straight lines radiating from the centre point of the base line.

### M.T.R. System.

The Multiple Track Radar Range is a short-based hyperbolic system, that is to say, the length of base line used is relatively short in comparison with those of such systems as *Gee*, *Loran* and *Decca*. In typical M.T.R. systems which have been tested and used to date the base line has been 5 to 10 miles long, so that outside a distance of 10 to 20 miles, straight radial tracks have been obtained. This performance is in accordance with the primary purpose of the Multiple Track Range, which is to be, in terms now internationally agreed upon, a *short-distance aid to navigation*; that is to say, an aid which is effective up to distance of about 100 miles and which is intended to guide aircraft to the vicinity of airports, where the so-called *aids to approach and landing* take over.

Given two M.T.R. stations at some fixed distance apart, the number of tracks which can be defined depends upon the accuracy with which the difference in pulse arrival time can be measured in the aircraft. In systems of the accuracy which has been used up to the present a typical figure is that for a station separation of about 9 miles 30 hyperbolic tracks can be defined, or expressing it another way, 60 radial lines can be drawn as emanating from the pair of stations.

If greater precision in time-difference measurement in the aircraft is achieved then more tracks could be drawn for a given station spacing. However, it can be clearly seen that there is no great benefit to be derived from providing more than 60 radial tracks this number is sufficient to meet all ordinary navigational requirements. The tendency in current development is to use in another way any further increase in precision of time-measurement, namely, to reduce the



MTR master station equipment. The sub-modulator is at the top and the modulator and oscillator within the cubicle.

station spacing while keeping the number of tracks provided the same as before. Smaller station spacings usually make station location easier, and assist from the administrative point of view.

### Blank Regions.

It will be noticed from Figure 2 that there are two *blank* regions in the track system, where no tracks are drawn. Throughout these regions the difference in pulse arrival time varies only slightly so that it becomes difficult to distinguish different tracks. Because of this lack of definition, these regions are not used. These gaps in coverage do not usually represent a serious disadvantage, since they form only a small fraction of the angular coverage, and it is usually possible to so orientate the system that tracks are provided along the principal air routes to be served. Should it be desired for some reason to provide coverage in the *blank* areas this may be done by superimposing a second track system (usually only one additional station is required) on the first so that the tracks of the latter fall within the gaps of the first.

## The Ground Stations.

The ground stations of a single M.T.R. system are two in number. Each station is essentially a pulse transmitter, and it is necessary that the pulses from each be transmitted in synchronism (not necessarily simultaneously, but with some fixed time relationship between them). The simplest way to achieve this to make one station determine the rate of transmission of pulses (this is then known as the master station); each pulse from the master is radiated omnidirectionally to aircraft and is also received at the second station (known as the slave station), where it causes a corresponding pulse to be radiated from the latter. These slave pulses also go out omnidirectionally to all aircraft within range. In this way synchronization of pulses is assured, since the slave station is under the control of the master station.

## The Master Station.

The units comprising the master station equipment are shown in block schematic form in Figure 3.

The first unit in the chain is an audio-oscillator, which is of importance because it determines the pulse repetition rate for the whole system. It is a 3-stage oscillator of the R-C phase-shift type, special attention being paid to the components to ensure stability of frequency. The latter is important for two reasons: firstly, if the master frequency varies greatly the slave station pulses may fall out of step with those from the master, so that synchronism is lost; secondly, where there are two M.T.R. systems adjacent (say along an air route), pulse repetition frequency is sometimes used as a basis for discriminating between the systems, and therefore, must be closely controlled.

The audio oscillator is used to drive a pulse-forming circuit, usually of the multivibrator or blocking-oscillator type. The resulting pulses of suitable shape and duration are fed to a modulator-oscillator unit of a standard radar type. The modulator-oscillator used in M.T.R. ground equipments built so far has been part of an Australian service air-warning radar equipment; it consists of a push-pull oscillator using two VT90 valves, series-modulated by two 833 valves. The frequency of operation is about 200 Mc. The pulse repetition frequency of the master station is about 2,500 pps, and

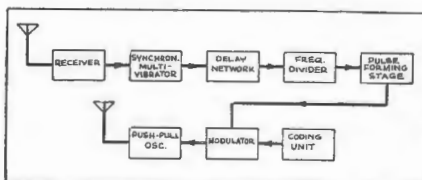

Block schematic diagram of MTR slave station.

the radiated pulse length about 1 micro-second.

The audio-oscillator and pulse-forming stages are housed in a small cabinet mounted on top of the standard cubicle containing the modulator-oscillator and main power supply. The form of construction may be seen in Figure 4.

The aerial is required to be omnidirectional, and takes a simple mechanical form. It is depicted in Figure 5. A central dipole section is fed from coaxial line. This dipole is connected in series with two further dipoles, one at each end. At the junctions of the dipoles phasing coils are placed, with the result that the current distribution in all 3 dipoles is similar. A gain of about 3 db in the horizontal plane is obtained with this aerial.

The aerial is usually mounted at the top of a wooden pole some 60 feet high.

## The Slave Station.

The units comprising the slave station equipment are shown in the block schematic diagram of Figure 6.

The first unit in the chain is the receiver. This is a conventional radar receiver of the superheterodyne type, operating in the 200 Mc and picking up signals radiated by the master station. This receiver is not required to be particularly sensitive, since a strong signal is received from the master, which is relatively close and usually within line of sight.

The output of the receiver is fed into a multivibrator, which has a natural frequency of operation of about 2,500 cycles/sec. Provided the latter frequency is close to that at which the master is radiating pulses the effect is that the multivibrator is caused to fall into syn-

# Radio Engineers

are you

## QUALIFIED?

### GET THIS FREE BOOK



It tells you how, by home study, the B.I.E.T (British Institute of Engineering Technology) will train you for a successful Radio Engineering career.

Professor A. M. Low, noted British Scientist and Inventor has stated "... the methods employed by the British Institute of Engineering Technology are in advance of any similar service offered ..."

### B.I.E.T. Courses embrace:

A.M.I.E.E. Examination.  
A.M. Brit. I.R.E. Examination.  
A.M.I.R.E. Aust. Examination.  
General Radio Engineering.  
Radio Servicing, Maintenance and Repairs.  
Radio Engineering and Design.

Short Wave Wireless.  
Practical Television.  
Talking Picture Engineering.  
P.M.G.'s. Operators' Certificates of Proficiency.  
and Radio Inspectors' Examination.

## THE BRITISH INSTITUTE OF ENGINEERING TECHNOLOGY

(CENTRES THROUGHOUT THE WORLD)

Australasian Administrative Offices: Macdonell House, 321 Pitt Street, Sydney  
Melbourne Branch ———— 414 Collins Street, Melbourne  
Adelaide Branch ———— Tattersall's Chambers, 14 Grenfell Street, Adelaide  
Brisbane Branch ———— A.M.P. Building, Edward Street, Brisbane

POST THIS  
COUPON  
NOW

The British Institute of Engineering Technology.  
Please forward FREE OF COST your Handbook—"ENGINEERING OPPORTUNITIES" containing particulars of your radio engineering and allied courses of instruction.

NAME \_\_\_\_\_  
ADDRESS \_\_\_\_\_  
OCCUPATION \_\_\_\_\_ AGE \_\_\_\_\_

R.S.2.

Please Mention RADIO SCIENCE when Replying to Advertisements,

RADIO SCIENCE, June, 1948



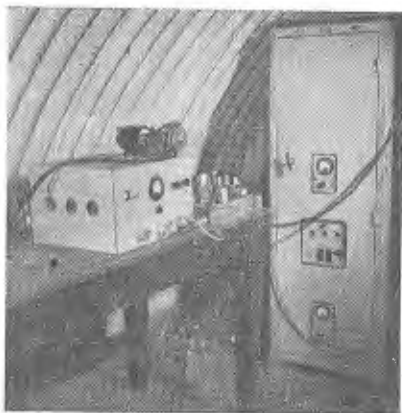

MTR slave station equipment. The photograph shows an experimental set-up at the Radiophysics Laboratory. Receiver and sub-modulator on the bench, modulator and oscillator in cubicle.

chromism with, or become *locked* to, the master signals. This synchronized multivibrator is the source of pulses for the slave station.

The pulses of the multivibrator output are first passed through a delay network. This artificially delays the pulses by a period of some 25 microseconds, and its purpose is to ensure that the slave pulses do not arrive at an aircraft within a certain minimum interval following the receipt of the master pulses. This procedure is necessitated by the action of the time-difference measuring circuits in the aircraft, which are arranged to commence operating when a master pulse is received and which do not function satisfactorily if the slave pulse arrives too closely "on the heels" of the master pulse. The action of these circuits will be discussed more fully in the next part of this paper.

The output pulses of the synchronized multivibrator having been delayed, are fed to a frequency-dividing stage. This stage responds only to every alternate pulse applied to it, and give out pulses which have therefore one-half the frequency of the master station, that is, 1,250 cycles/sec. approximately. This change in fre-

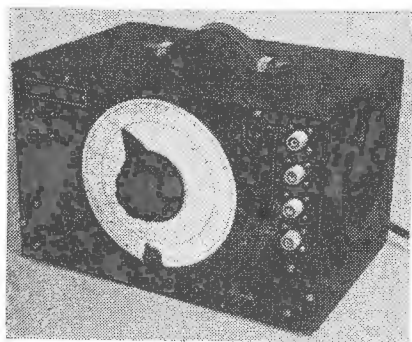

A phase shift oscillator is one of the pieces of test equipment used in checking MTR ground station performance.

quency is made to allow the use of a procedure in the aircraft such that the time-difference measuring circuits can be set in operation by the receipt of master pulses only, and not slave pulses; this procedure will be discussed more fully later. Thus by frequency division the slave pulses are "labelled" to distinguish them from master pulses; notice, however, that synchronism is maintained, there being two master pulses to each slave pulse.

From the frequency divider the pulses go to a pulse-forming stage, which renders the pulse of suitable shape and duration. The pulse-former is followed by modulator and oscillator stages identical with those already described for the master station.

### Identifying Signal.

The streams of pulses passing to the modulator is interrupted periodically by a motor-driven coding wheel so as to provide a sequence of dots and dashes making up a Morse code identifying signal. This code is received in the aircraft and enables the pilot to identify the particular track system he is using.

A photograph of a slave station equipment in experimental form is shown in Figure 7. On the bench may be seen the slave receiver and the sub-modulator unit, comprising those stages up to the pulse-former; the coding unit is also seen here. The cubicle houses the modulator and oscillator.

The slave transmitting aerial is identical with that described for the master station. The receiving aerial at the slave station is usually a single dipole, which may be partially screened to reduce unwanted pick-up. Both aeriels may be seen in Figure 8, which is a view of an experimental slave station installation at Melbourne used during airline trials of the equipment.

### Test Equipment.

To allow the necessary adjustments to be made during the installation of M.T.R. ground stations and to provide for subsequent regular checking of the performance of the stations in operation a number of specialised pieces of test equipment have been designed and built.

Perhaps the most important single requirement for an M.T.R. system is that the tracks shall at all times be accurately positioned in accordance with the published map of the track system. This requirement reduces to an accurate adjustment, which shall remain stable, of the overall delay in the slave station (i.e., the time interval between the receipt of a master pulse by the slave receiver and the transmission of the corresponding slave pulse). To make this

Other adjustments which require precision in measurement are those of the frequency of the audio oscillator in the

adjustment precise, measurement of the overall delay must be possible. This is done by displaying the received and transmitted pulses simultaneously on a cathode-ray tube of which the time base is accurately calibrated. The calibration is effected by superimposing on the time base *pips* at say 1 microsecond intervals, derived from a crystal oscillator.



View of the MTR slave station used in trials on Sydney-Melbourne air route. The main transmitter aerial is at the top of the wooden mast and the slave receiving aerial below it.

master and the synchronized multivibrator in the slave station. These frequencies are measured by comparison with a stable oscillator of the phase-shift type, which is in turn checked against an audio signal produced by frequency-division from a crystal. The stable phase-shift oscillator is shown in Figure 9.

Finally, the pulses from both master and slave stations are usually monitored at some convenient point in the vicinity, such as a control room or workshop. For this purpose a special monitor receiver and a cathode-ray tube display have been provided. In particular this receiver allows the technician to check that the stations are in synchronism by observing that the two pulses seen in the display are separated by a constant interval.

## THE SCOPE OF—

# Electronics in Industry

By MAURICE M. LUSBY B.Sc. B.E.

A general survey of the increasing fields of applications of Electronics as applied to industrial processes, and which are resulting in improved production methods.

Before the second World War, Industrial Electronics as a new industry was just stirring. Most of the special electronic tubes—tools of the electronics engineer—had already been developed and were finding widening fields of application. During the war, these tubes jumped into the fray and won colours for improved production methods and products. In the reconversion to peace their well earned place is retained in industry and expansion into new fields lacks none of the war-time momentum.

In addition to calling on many of the common tube types already developed for the communications industry, several entirely new families of tubes have been evolved specially for the needs of industry. These are:

- (a) **PHOTO-ELECTRIC TUBES**—sensitive to various bands in the visible and near visible spectrum from short ultraviolet (Schuman rays) through to long infra red.
- (b) **THYRATRON TUBES**—gas filled tri-

odes and tetrodes with relatively heavy current controlling capacity.

- (c) **IGNITRON TUBES**—mercury pool cathode rectifiers with firing angle control as in thyratrons—but having even greater current carrying capacity up to 1,000 amps or so continuously.
- (d) **PHANOTRON TUBES**—mercury vapour diode rectifiers greater in current capacity than most mercury vapour rectifiers used in Communications.
- (e) **KENOTRON TUBES**—high vacuum diode rectifiers for high voltage (up to 230 KV) at relatively low current.
- (f) **MISCELLANEOUS TUBES**—for voltage regulation, surge suppression, Pirani pressure gauges and ionisation gauges (Geiger-Muller tubes), also special tubes for individual applicators such as leak detectors, mass spectrometers, etc.

The common amplifier—oscillator family of tubes, when applied industrially, are called *Pliotrons*. All these special family

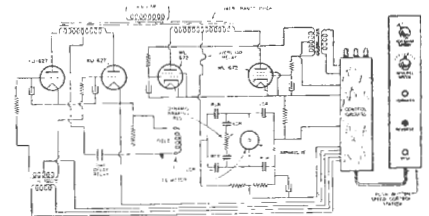

Fig. 1.—Circuit diagram of an electronic motor speed controller.

names have been universally adopted by the Industrial Electronics Industry.

The breadth of application of these tubes is so wide and scattered that it is difficult to do justice to each individual apparatus in a generalised article such as this. Therefore, Table 1 is presented in order to show some (by no means all) important uses of electronics in industry. Selected individual uses of electronic tubes will now be described from each group of applications, followed by necessarily brief mention of some of the remainder.

Table 1. TYPICAL APPLICATIONS OF ELECTRONICS IN INDUSTRY

CONTROLS FOR	MEASUREMENT AND ANALYSIS	HEATING	COUNTING & SORTING	Manufacture of radio-active isotopes Radar aerial surveys
Time intervals	Mathematical analysis	<b>Dielectric</b> Plastic moulding Rubber curing Glueing Sterilisation Cooking Dehydration <b>Induction</b> Heat treating Metals Brazing & soldering Shrinla fitting Degassing Microwave "blowtorch"	Counting pack-ages Sorting and grading Rejecting faulty parts Metal detection in wood Pinhole detection	<b>SUPERSONICS</b> Flaw detection Chemical processing Germ and insect killing Supersonic Inspection Delaying Transients, etc. Depth Sounding Geophysical surveys
Welding	Chemical analysis Dynetric balancing Colour analysis Vibration analysis Noise measurement	<b>CONVERSION</b> Electro-chemical processes Traction power Electrostatic precipitation for material recovery Welding Electrostatic paint spray and de-tearing Voltage stabilisation	<b>ACCIDENT PREVENTION</b> P.E. cell barriers Fire and smoke detection Burglar alarms Overtravel and overflow Traffic signals Electronic cut-outs	<b>QUALITY CONTROL</b> Pinhole detection in strip metal Thickness control Colour analysis Checking electrical valves Surface analysing X-ray examination
Motor speed torque	Leak detection Speed Time Thickness Dust & particles Temperature Humidity Pressure Vacuum Ionization gauges Materials testing Electron microscope X-ray diffraction Insulation testing PH recorders			
Frequency				
Electric load				
Door opening & closing				
Humidity				
Dust				
Material flow				
Material size				
Colour				
Illumination				
Liquid levels				
Remote control				
PH factor				
Railroad train control				
Circuit breaker closing				
Synchronising generators				

### Motor Speed Control.

One special control which warrants closer scrutiny is that of motor speed control. For many years the ideal of the infinitely variable gear pair has been sought by engineers. In recent years some mechanical solutions to this problem have been reached and in some cases widely used. However, the need for reversing through zero speed with full or constant torque has not been solved mechanically and those mechanical devices which do give so-called infinitely variable speed not only lack efficiency but they seldom provide the ideal torque speed characteristics.

Now, with the aid of Electronics electric motor drives can be had which give up to 100 to 1 ratio of speed either forward or reverse, with the characteristics supplied at will for (a) constant torque throughout the range or, (b) constant horsepower.

A typical circuit of the electronic motor speed control is given in Figure 1. A

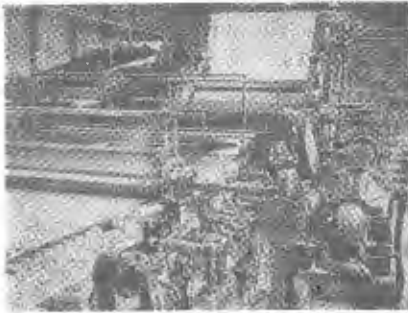

Fig. 2.—Electronic control of group of motors in paper mill. General view of the drive showing eight section drive equipments.

D.C. shunt wound motor is used, which draws its rectified supply from A.C. mains through the electronic circuit. (The diagram given is for small single phase use, but 3-phase systems are used for more powerful drives.) In general the system consists of supplying the armature circuit through Thyatron tubes and varying armature voltage with the Thyratrons to obtain a 20:1 stepless speed variation, below base speed. In addition, smaller thyatron tubes control the shunt field current and obtain further speed increase above base speed by weakening of the field.

Electronic motor controls of this type are used extensively in continuous mills such as in the textile, paper and wire drawing industries. A complete line of drives can be coupled to single control so that one adjustment keeps the relative speeds constant for all overall rates of travel of the material being processed. Figure 2 shows a paper mill where drives are coupled up in this fashion.

### Electronic Measurement and Analysis.

The measurement of the basic electrical reactance, impedance—by electronic means is not new. The valve has long been

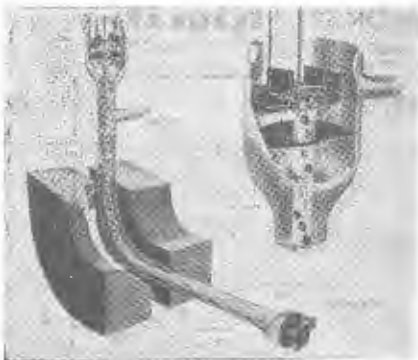

Fig. 3.—Electronic Mass Spectrometer. A stream of ions is projected into a magnetic field, where deflection of ions is proportional to their weight. Ions of a chosen type are caught up on the final collector plate—the current flow then indicates relative concentration.

recognised for its value in providing accurate information without distorting the characteristics of the components being measured. In many of the uses of electronics given in Table 1 under the above heading; sensitive photocells or pliotrons are used to extract the primary information. Other valves may then be used to amplify, analyse or otherwise convert the primary information into the desired form.

In many of the industrial uses of electronics for measurement and analysis—the process is carried a step further where the information gathered is used to control processes which the method indicates have departed from standard quality.

However, it often happens that the measurement or the analysis is itself the desired objective. For instance, the *mass spectrometer* (Fig. 3) is really an electronic chemist in that every trace of each chemical atom or molecule entering the ionisation zone may be unfailingly made to register its presence and its concentration on the collector circuit microammeter. The gas leak detector is similar in principle, but is set to sound an alarm when a dangerous concentration of leaking molecules of one kind is sensed.

In vibration analysis electronic devices measure the frequencies and amplitudes of the components of vibration and aid in determining their causes. The Dynetric balancer checks rotating parts for dynamic balance and indicates the sizes and positions of added weights to give perfect balance.



Fig. 6.—Resnatron tube delivers 50 kW at Microwave frequencies. It may be applied to Microwave heating.

The electron microscope and X-ray diffraction techniques have come as new tools to increase man's knowledge of the infinitesimal. The new vistas and widening horizons of science which these instruments open up put them well beyond the present field of everyday electronics in industry.

### Electronic Heating.

The use of radio frequency fields created by fairly powerful R.F. oscillators

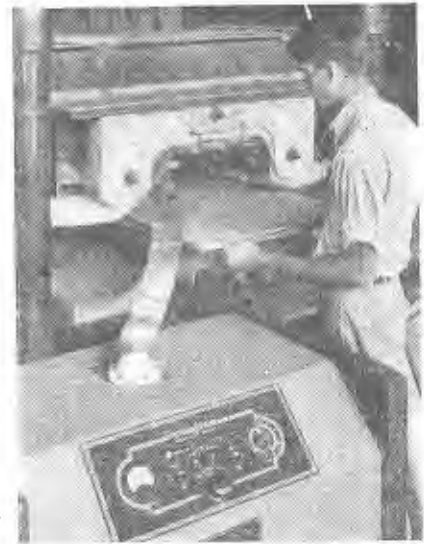

Fig. 4.—Use of dielectric heating in furniture manufacture. Plys are formed to shape, plastic bonded and cured in one operation.

tors for heating purposes had been used for years in the actual manufacture of radio tubes. In effect, the metal parts of a tube electrode assembly, contained within the glass envelope, were placed in a strong R.F. field. Due to the circulating currents set up in the metal parts, heat resulted which drove out gases trapped in the metal. These gases were pumped away and the technique resulted in a "harder" vacuum which gave the tubes longer life.

This form of R.F. heating is called *Induction Heating*, and the R.F. frequencies employed are generally below 300 Kc. Induction heating is not only used for heat treatment but also has extensive use in soldering and brazing. It is used also to "re-flow" the tin coating on tinplate so that an uneven film of tin is made into a uniform, pin-hole free layer.

Another characteristic of radio frequency fields is that insulating material may be heated due to absorption of energy in a dielectric sense. Thus



Fig. 7.—Photo-electric relay and associated light beam count packages on moving conveyor.

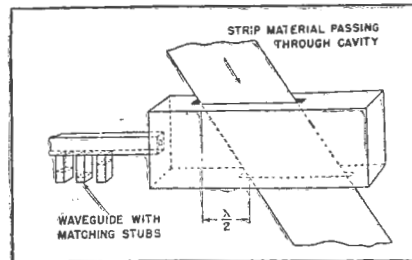
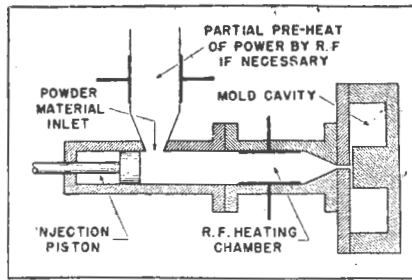
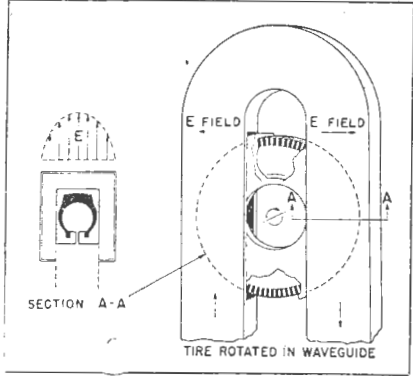
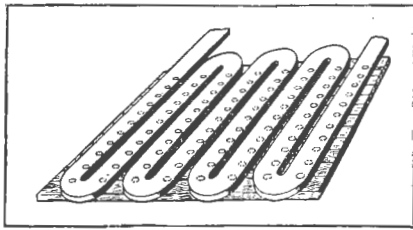

Fig. 5.—Suggested applications of Microwave Heating: (a) Spot glueing; (b) Jet moulding; (c) Tyre curing; (d) Strip heating.

Dielectric Heating became the second major field of Electronic Heating. Dielectric Heating is brought about by arranging a two plate condenser and placing the material to be heated between these plates, where its dielectric loss gives rise to heat—internal heat. Thus we have a means of heating materials from

the inside as distinct from conventional heating from the outside. Much higher frequencies of 12 Mc or more are used.

Dielectric Heating is also very popular as a speed-up factor in plywood manufacture and furniture manufacture where plastic glues are employed which are

rapidly "set" under pressure using R.F. heat. (See Fig. 4.)

More recently Microwave heating has been investigated as an electronic *Blow Torch* in industrial heating. Heat is literally "hosed" from wave guides at the object to be dielectrically heated. Promising uses of microwave heating are

- (a) Spot tacking of glue lines on edge glued timber.
- (b) Jet moulding with Preheated Power instead of pellets of plastics.
- (c) Automobile tyre curing.
- (d) Heating of strip dielectric material in continuous process.

Illustrations of practical arrangements to give these results are shown in Figure 5, an oscillator tube—the *Resnatron*—capable of delivering continuously 50 KW of microwave energy is also illustrated in Figure 6.

### Electronic Counting and Sorting.

Light beams which present no solid obstacle to the passage of merchandise along a conveyor are used to operate relays or counters through phototube receivers. (See Figure 7.) They can count the number of packages passing a given quantities—resistance, capacity, inductance, point and can also be arranged to discriminate between tall and short packages and to operate points to switch the tall items to one branch conveyor—the short ones to another.

# Marconi School of Wireless

CONDUCTED BY AMALGAMATED WIRELESS (AUSTRALASIA) LTD.

For 34 years the leading Radio College in Australia

Courses are available for:

**RADAR OPERATORS AND TECHNICIANS, RADIO OPERATORS AND TECHNICIANS, SERVICE MECHANICS, AMATEURS, MORSE TELEGRAPHY**

Call, 'phone or write for full particulars

**MARCONI SCHOOL OF WIRELESS**

47 York Street  
SYDNEY

Tel. B0522

163 Queen Street  
MELBOURNE

Tel. MU9161

**POST THIS NOW!**

MARCONI SCHOOL OF WIRELESS

Box 2516, G.P.O., Sydney.

Please send without obligation full details of your courses.

Name.....

Address.....

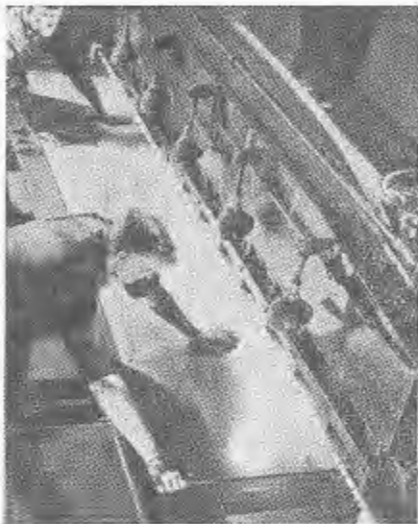

Fig. 9.—Light source and photo-tube housing located on a shear for protection of operator's hands.

Similarly, light beams and P.E. tube receivers are used as pin-hole detectors in continuous metal strip mills. Faulty sections may be passed to flying shears by light beam detection and eliminated from the main run. Alternatively a dash of paint can automatically be given to the points where pin-holes are detected to make sorting easier by manual inspection at a later stage. Figure 8 illustrates a pin-hole detector which detects holes as small as 1/64 inch at strip speeds from 100 to 1,000 feet per minute.

Getting away from Photoelectric systems, it is interesting to note that the U.S. Corps of Engineers have recently installed an electronic system for detecting metal in lumber which floats through a very large diameter search coil partly submerged in the water way. This system will detect metal fragments and unexploded artillery shells before the lumber reaches the mills, thus saving damage to rotary saw blades.

### Electronic Conversion of Power.

With the ever-increasing popularity of alternating current for economical distribution of power, many industrial uses of direct current still remain to be provided for by A.C. to D.C. conversion at, or near to, the point of use.

For example, in chemical products manufacture, large use of D.C. for electrolytic processes cannot be avoided. Public conveyances still use D.C. for its better flexibility in speed and load handling.

For many of these conversion jobs, Ignitron rectifiers are ideal. They may be of the sealed type up to about 1,000 amps, or of the continuously pumped type at greater loads. They may be arranged in parallel banks to meet extremely high demands at pressures up to about 2,000 volts.

The flexibility of control of heavy electrical current by ignitron tubes has revolutionized the practice of electric welding. Electronic welding controls are now widely used for many different types of welding—spot, butt, seam welding, etc. Electronic seam welders, for example, are used literally to "stitch" up sheets of 1/8 inch metal just like a sewing machine in effect. To achieve this, electronic circuits measure individual cycles of A.C. and feed firing pulses to the ignitron tubes such as that, for example, three cycles of welding current may be interspersed between 20 cycles of zero current to produce evenly timed stitches which are regularly spaced.

### Radiation in Industry.

Electromagnetic waves or radiations cover a very wide spectrum, having many wave bands with very special characteristics.

The shortest waves used industrially are X-rays, and in order of increasing wave length, we come in turn to Schuman rays, germicidal rays, sun tan rays, rays causing fluorescence in chemicals, and thence via violet into the visible light band. Beyond the red end of the visible spectrum we come to infra red heat rays and thence to micro wave and on through short waves to the broadcast radio bands.

Schuman rays of about 1,800 Angstrom units wave length produce ozone in air and are used industrially for chemical purposes. Germicidal rays are in the region 2,500 An. and are becoming a necessary feature in many food industries as well as for sanitation in hospitals and for control of air borne infection in public buildings, offices and homes.

Sun tan rays—identical with those from the sun—have wave lengths from 3,000 to 4,000 Au. These rays may be produced electronically from mercury vapour tubes and are used in certain chemical reactions. They form the core of fluorescent lamps, their wavelength being converted to white light by the coating of fluorescent powder on the inside of the tube.

Infra red waves used for Therapy treat-



Fig. 8.—A typical installation of a photoelectric pin-hole detector on a strip metal shearing line.

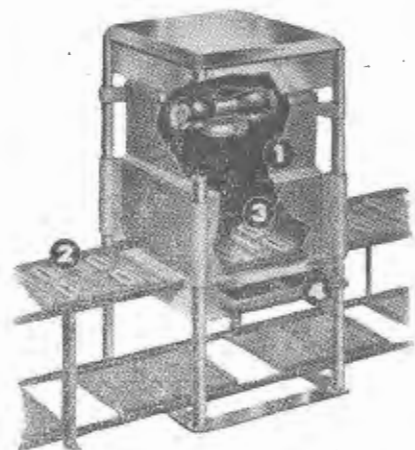

Fig. 11.—X-ray inspection of manufactured parts. 1. The X-ray tube head; 2. Specimens approaching conveyor; 3. Specimens being X-rayed; 4. Film drawer.

ment, and now for industrial heating and drying, are produced mostly by filament type lamps which are, therefore, not normally called electronic devices. However, in recent years, microwave generators have been pushed down in wave length so far that the wave lengths now overlap the infra red section of the spectrum. Resulting from atomic research, two additional forms of "particle radiation" are now coming into the industrial fields.

High speed electrons, accelerated down a gigantic cathode ray tube with ten million volts on the final anode have been found to kill germs and other organisms. By firing pulses of these high speed electrons, one millionth of a second in duration, this sterilisation action can be had, free of chemical side reactions. Such germicidal radiation, it is claimed, has greater penetrating power than ultra violet germicidal rays which normally are applied only to the killing of germs in air or transparent fluids only.

Bi-products of the manufacture of uranium and Plutonium—the radio active isotopes of carbon, phosphorous etc. are now being used industrially and medically.

Radio active carbon may be introduced into process material and the flow of metal in castings, drawings, etc., or of foods in the human body etc. can be traced using Geiger-Muller counters. Thus much vital information can be obtained by external observation. The mixing of ingredients in food manufacture can be checked and controlled by a similar technique.

### Electronics in Accident Prevention.

Arrangements of light beams, photoelectric cells and relays can be used to improve safety in dangerous machinery. For example, Fig. 9, indicates how a light beam prevents the operation of giant

(Continued on page 46.)

OUR HUGE EXCLUSIVE PURCHASE OF

# A.C.-D.C. UNIVERSITY MULTIMETERS, MODEL MVA

ALLOW US TO SELL THEM TO YOU AT THIS LOW PRICE

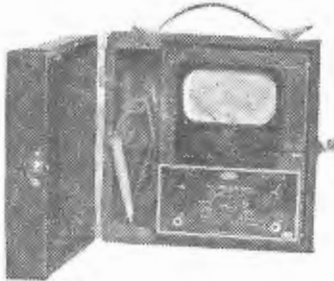

<b>RANGE</b>	<b>FEATURES 4½" SQUARE</b>
Volts AC-DC—10, 50, 250, 1000	1000 ohms per volt.
M.A.S.—1, 10, 50, 250	Attractive Leather Bound portable Case. May be used on bench or in case. Both types supplied with test props.
Ohms RX1, 10, 100, 1000	<b>WEIGHT—8lb. packed.</b>

PRICE:—BRAND NEW AND IN ORIGINAL CARTONS ..... £7/10/0

SLIGHTLY USED BUT IN GOOD CONDITION ..... £5/10/0

POSTAGE: N.S.W. 2/6; INTERSTATE 5/-

### FILTER CHOKES

100 M/A 20H ..... 7/6 each  
50 M/A 30H ..... 6/- each

### RELAYS

10,000 ohm Contacts U.S.A. 6/6 ea.  
200 plus 200 ohm double wound  
Contacts U.S.A. .... 5/- each  
250 ohm Contacts U.S.A. 5/- each  
40 ohm (6v.) Ceramic Midget 1  
Contact U.S.A. .... 5/- each  
6v. Solenoid 1 Contact 5 amp 6/- ea.  
24v. Solenoid 1 Contact 5 amp 5/-  
each

Post: N.S.W. 6d. each

### VALVES

6AC7 ... 15/-	12A6 ... 15/-
9001 ... 17/6	12H6 ... 12/6
6SH7 ... 10/-	12AH7 ... 12/6
6H6 ... 7/6	12SQ7 ... 12/6
EA50 ... 7/6	12SR7 ... 12/6
EF50 ... 10/-	12SQ7 ... 12/6
717A we 12/6	7F7 ... 15/-
VT90 Micro	7N7 ... 15/-
Pups ... 10/-	7Y7 ... 15/-

Post: N.S.W. 6d. each

### BREAST TYPE TELEPHONE SETS

Complete Microphone and Receiver,  
10/- each. Post: 2/- N.S.W.

### KEY SWITCHES

Double pole throw contacts 5/6 each.  
Post: N.S.W. 6d. each

### I.F. TRANSFORMERS

A.W.A. 455kcs. 1st and 2nd Var.  
Iron Core ..... 5/6 each  
U.S.A. 6.9 mcs. 1st, 2nd, 3rd Var.  
Iron Core ..... 7/6 each  
Post: N.S.W. 6d. each

### CERAMIC COIL FORMERS

Low Loss Type 2" x 3/8" diam. Easy  
mounting. Complete with Variable  
Iron Core ..... 2/6 each  
Post: N.S.W. 6d. each

### GENEMOTORS

Input Volts	Output Volts	Output M.A.'s	Price Each
24/28	250	100	30/- ea.
24/28	550	350	70/- ea.
24/28	375	150	50/- ea.
18v.	450	60	35/- ea.
12v.	1200	200	90/- ea.
12v.	230	100	40/- ea.
9v.	450	60	35/- ea.

### PUSH BUTTON SWITCHES

5 pole each 2 pair  
of contacts made  
in U.S.A. Ideal  
for receivers, multi-  
meters, etc. .... 12/6  
Post: N.S.W. 9d.

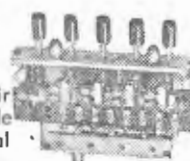

### "WALTER" LIFE BOAT TRANSMITTERS

160-170 mcs. Peanut 1.4v. Valve  
12/6 each.  
Post: 2/-

### DRY PLATE RECTIFIERS

½ Wave Copper Oxide 5 M.A.  
2/6 each.  
Full-Wave Bridge Copper Oxide  
100 M.A. 3/6 each  
½ Wave Selenium 24v. 10 amp.  
50/- each.

### COAXIAL CABLE

540 ohm. Any length 1/6 yard.  
Coax. Connectors, 3/- pair

### POWER TRANSFORMERS

240/110v. Auto 250v-A ... 25/-  
240v. Prim. 750v. CT 750v. Sec.  
1.5KVA 90/- each  
240v. Prim. 6.3v. CT 8A— 6.3v.  
8A—5v. 3A Secs. .... 15/-

### METERS

0-5 M.A. 2in. Flush 15/- each  
0-50 M.A. 2in. Flush 15/- each  
0.20 volt DC 2in. Flush 15/- each  
0-1000 volt AC 2in. Flush Rect.  
type ..... 25/- each  
0-350 volt AC 3in. Protruding 30/-  
0-300 M.A. Thermo Couple 15/- ea.  
0-1 amp. Thermo Couple 15/- each

# ELECTRONIC EQUIPMENT CO.

LM3555

29B WEST STREET, LEWISHAM, SYDNEY

LM3555

(Opposite end of Lewisham Hospital)

Please Mention RADIO SCIENCE when Replying to Advertisements.

RADIO SCIENCE, June, 1948

# SURVEYING BY *Radar*

By J. WARNER, B.Sc., B.E.

This second article describes the application of radar to geodetic surveying as well as the method of measuring lines some hundreds of miles in length to a very high degree of accuracy

A previous article described how radar was used as an aid in an aerial photographic survey and indicated the possible elimination of much of the ground survey at present necessary to produce maps for aerial photographs. The type of radar equipment used was also described and as an example an outline was given of the method of operation of the *Shoran* equipment.

## Geodetic Surveying

A further application of radar is to geodetic surveying. It is at present necessary, when using ground survey methods to link up widely separated points on the earth's surface, to build up a network of points spaced roughly 20 miles apart. This limit is set by the curvature of the earth preventing objects further away from being seen from ground level. Atmospheric conditions in the form of airborne dust, water vapour, etc., also impose a limit on the maximum distance to which one can accurately use optical instruments.

Hence, in order to measure a line 100 miles in length, some such network of points would be necessary, as in the accompanying figure where A and B are two points whose distance apart is accurately known and C is the point whose position it is necessary to determine. The intervening lines represent angle measurements necessary to carry forward the distance AB to find the position of C. As can be imagined all this involves a con-

siderable amount of work as each of these intervening points must be visible from its immediate neighbours and surveying instruments must be carried to each point in turn.

Another method of determining the separation of points on the earth's surface is by finding their positions separately by means of astronomy. Due to the fact that this type of measurement involves the use of a vertical line at each point and that the vertical is defined by local gravity effects, the method is limited and errors upwards of a hundred feet are common. The method is hence inadequate for the most accurate surveys.

Radar does provide a rapid means of determining the distance between two widely spaced points with an accuracy approaching that of a high quality ground survey. The method by which this is done can be explained by referring to the accompanying figure.

## Line Crossing Method.

In the plan view, the aircraft carrying the radar gear is shown flying across the line joining the two ground beacons, which are situated at the points whose distance apart it is desired to measure. Simultaneous measurements are made of the distance to each beacon. At the crossing point  $AP_0$  and  $P_0B$  are measured and the distance  $AB$  then calculated, taking into account the aircraft height  $H$ , the earth's curvature, and the fact that

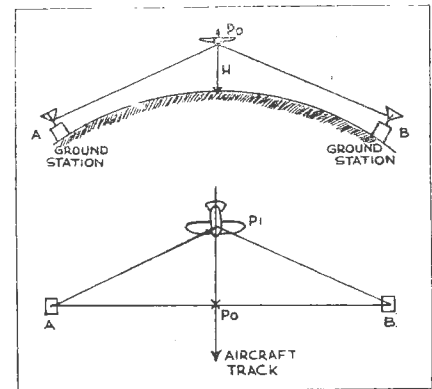

The line crossing method of determining distance.

radio waves travel in a slightly curved path due to changing atmospheric conditions.

In practice, since it is difficult while in the aircraft to know exactly when the crossing point is reached, measurements are made of  $PA$ ,  $PB$  at intervals of a few seconds as the crossing is made, and the sum of the two distances determined. This is then plotted against time and a smooth curve drawn through the experimental points.

The minimum sum distance corresponding to  $P_0A$  plus  $P_0B$  is then determined from the graph. This method has a further advantage apart from obviating the necessity of making a measurement exactly at  $P_0$ , and that is that experimental errors in any of the individual reading of  $PA$ ,  $PB$  will be reduced in fitting a smooth curve through them, thus giving greater accuracy to the minimum sum of  $AP_0B$ .

## Maximum Distance

Since U.H.F. radio waves follow nearly optical paths, it follows that if a signal is to be received the aircraft must be at a sufficient height so that the earth's curvature does not obscure the radio line of sight to the beacon. Due to the fact that radio waves are bent or refracted by the atmosphere, and that the factors which influence the bending of the radio

Distance	Number of Observations	Mean Error (Miles)	Proportional Error
98.75	15	+0.007	1/14,000
148.54	13	-0.021	1/7,000
161.92	10	+0.001	1/160,000
173.75	22	+0.003	1/58,000
181.37	12	-0.008	1/22,000
215.56	11	0.000	—
227.29	23	-0.016	1/14,000
237.49	18	+0.001	1/240,000
308.53	19	-0.024	1/13,000

This table shows the results of a number of American experiments in the application of the line crossing method to precise distance measurement. The error quoted is the difference between the radar measurement of distance and an accurate ground survey value.

## DISTANCE FROM RADIOPHYSICS TO BEACON AT WENTWORTH FALLS

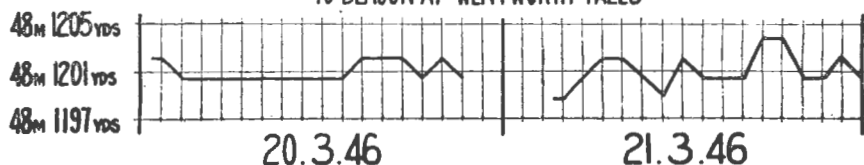

The results of some radar measurements from an equipment at the C.S.I.R. Radiophysics Laboratory in Sydney and a responder beacon at Wentworth Falls in the Blue Mountains. A series of measurements were taken at half hourly intervals on each day and the results plotted as shown.

Variations in readings amounted to plus or minus 2 yards in a distance of nearly 50 miles.

beam, namely, temperature, pressure and particularly humidity, decrease with increasing height, the beam follows a slightly curved path and can be received at somewhat greater than optical distances. Low frequency radio waves are not limited in range in the same way as are U.H.F. waves since they are diffracted round the earth's curvature in a similar way that sound is diffracted round obstacles.

The accompanying graph shows the way in which the maximum distance between a pair of beacons that can be measured by an aircraft varies with the altitude of the aircraft. From this it can be seen that a practical upper limit of 600 miles is set to the distance that can be measured in one step by radar means, and it is possible that greater economy would result in making more measurements using somewhat shorter distances.

### Accuracy Limits

So far little has been said of the accuracy of radar measurements. Errors may be introduced through a number of causes and may consist of equipment errors, errors due to unknown radio propagation conditions, or errors occurring in the process of reduction of the radar measurement to the distance on the earth's surface. It is only in the case of geodetic surveying that any of these errors are serious since distortion caused by unknown tilt of the aircraft camera outweighs other factors in aerial photographic surveying.

Equipment errors come about through small unknown delays in either airborne or ground equipment, errors in setting or measuring the position of pulses, or crystal oscillator frequency drift. When it is re-

membered that a radio wave travels out and back a distance of approximately 500 feet in one microsecond, it is easy to see that individual errors must be reduced to a few hundredths of a microsecond or less if an overall equipment error of the order of 100 feet is to be obtained. Errors of this type in *Shoran*, the equipment described earlier, are probably somewhat less than 100 feet and with care might be reduced to about 30 feet. These errors are independent of the distance being measured so that clearly it is an advantage to measure as great a distance as possible, since this reduces the proportional error.

The proportional error or ratio of error to distance being measured is in the best ground surveys about 1 part in 100,000 or 10 feet in 200 miles. To meet this accuracy with a radar set having an equipment error of 30 feet it would be necessary to measure lines at least 600 miles in length which is the maximum that can be measured as discussed above. Of course, by taking a number of readings it is possible to obtain a mean value which is more probably correct than the individual readings and is thus more accurate.

Crystal oscillator frequency errors will cause errors proportional to distance since the crystal frequency is a function of the velocity of the radio waves and the indicated distance is equal to this velocity multiplied by the measured time interval between transmission of a pulse and the reception of a reply from the beacon. If very special precautions are taken, it is possible to make crystal oscillators which maintain frequency to one part in 100,000,000, though the *Shoran* crystal is probably accurate to only a few parts in 1,000,000.

### Wave Bending Effect.

It was indicated earlier that the radio waves did not follow an exactly straight path but were bent slightly as they passed through the varying layers of the atmosphere. The determination of the exact degree of bending depends upon precise knowledge of the conditions of the atmosphere at every point along the path

of the radio ray. The atmosphere is, of course, continually changing, so that for the most accurate work it is necessary to make measurements during the time in which a radar survey is in progress. A consideration of present knowledge of the atmosphere and of present techniques of measurements indicate that it should be possible to make allowance for refraction to an accuracy of a few parts in 1,000,000 provided adequate measurements are made. Comparatively few measurements are necessary for an accuracy of a few parts in 100,000. It is important to notice, however, that no matter how good the radar equipment is made, it is impossible to get a more accurate result than that allowed by the knowledge of the atmosphere and its effect upon radio waves.

### Exact Height Essential.

Another important limit on accuracy comes to light when the reduction of radar measurements to distance on the earth's surface is considered. As stated before, in order that this can be done, the aircraft's height must be known. As a rough approximation for the majority of practical cases an error in height will cause errors in calculated distance of one twentieth of its own magnitude. Thus if an uncertainty of altitude of 100 feet exists when the aircraft is at say, 10,000 feet, then an error of five feet in distance will be caused, which corresponds to an accuracy of one part in 100,000 for a distance of 100 miles. It can be seen that this is important and that to get the best out of radar survey methods, it will be necessary to measure aircraft height to 20 feet or less. This is a very difficult matter and may require the development of new techniques before a fully satisfactory position is reached.

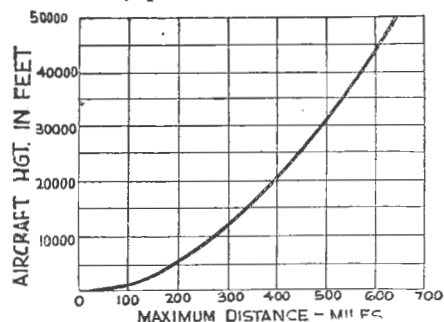

This graph shows the maximum distance that can be measured using the line crossing method.

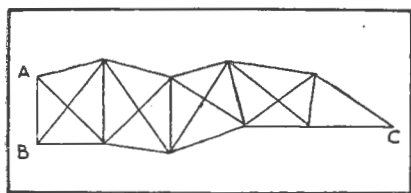

Ground based triangulation necessary to determine the distance BC.

### SUBSCRIBE NOW.

Make sure you receive every copy of "RADIO SCIENCE" by placing a definite order with your newsagent.

If you prefer, subscriptions may be made direct to our office—Box 5047, G.P.O., Sydney.

Subscription Rates at 12/- per year or 21/- for two years post free to any address in the Commonwealth.



# THE R.A.A.F. RADIO RESERVE

By ROTH JONES—VK3BG

**Working in close liaison with the Federal Executive of the Wireless Institute of Australia, the Royal Australian Air Force intends reforming its pre-war Wireless Reserve. This new body will be called the R.A.A.F. Radio Reserve and it will combine radar with normal wireless communication.**

To many the wireless Reserve of the 1930's is now forgotten, but to the veterans of the amateur radio ranks in Australia it will always be remembered. Its work in the early days of the war pulled the R.A.A.F. Signals Branch out of what was a "nasty jam."

This reserve permitted the R.A.A.F. to man vitally important telecommunication circuits without delay within a few days after war was declared. Its own men were insufficient, and reservists, who were called up immediately, were promptly put "on watch." The thorough instruction obtained through their association with the reserve allowed the R.A.A.F. to carry out a development plan of expansion which would have been considerably delayed without the able and loyal assistance of these reserve members.

Although there were 193 members on the pre-war reserve—most of whom were amateurs—they excelled themselves in every way. When the war finished 188 of them had commissions, one had risen to the rank of Group Captain and was Director of Telecommunications, while several others were Wing Commanders. Many became air crew and flew with aircraft all over the world and a number were decorated. Fortunately the deaths were extremely light.

## General Details.

When announcing details of the Radio Reserve, the Minister for Air and Civil Aviation (Mr. Drakeford) said the new body required at least 230 officers and 1,800 men who would enter the service under the conditions pertaining to the regular R.A.A.F. reserve, details of which were announced in all Australian newspapers in February. Briefly these conditions were: engagement for five years and further re-engagements, each of five years, applicants must volunteer, possess honourable discharges and be medically fit for service and report annually to the Air Board. Personnel appointed to the reserve will be given the temporary rank previously held.

Under direction from R.A.A.F. headquarters, the Chief Signals Officers of each R.A.A.F. area will be responsible for Radio Reserve Training. Immediate proposals in the training field include

many of the new R.A.A.F. radio installations—several of which are post-war. These include (a) radio teletype communication system using frequency shift and single side band techniques. This combined with the tape relay system of traffic handling and a new system of very high frequency tone keyed radio links, will provide a modern and efficient communication system.

(b) Operation and maintenance of high power radio transmitters for broadcasting meteorological information. These are now being installed at Canberra under international agreement, and provide for weather transmissions from Australia to be linked with a chain of similar transmissions extending from South Africa to Hawaii.

(c) Theoretical, practical and general knowledge of the V.H.F. communication equipment now being installed in R.A.A.F. aircraft to provide efficient air-ground communication, and use of the Department of Civil Aviation's radio ranges.

## Modern Instruction.

Although much time will be devoted to ground installations the air side will not be neglected—especially as the R.A.A.F. is to the fore in many of the latest radio aids to flying. Approach and landing aids will also be included among the reservists' instruction. Latest acquisition in this field is G.C.A. (Ground Controlled Approach), one of the modern aids used in Britain and America which enables operators on the ground to see the exact position and height of an aircraft near the airfield and to guide it to a landing by radio telephone. One of the stations is at present operated by the R.A.A.F. at Iwakuni, Japan.

Another landing aid which seems sure to be included in reserve instruction is "Instrument Landing System" (I.L.S.), which comprises equipment fitted in the aircraft and operated by the pilot. Indications received from the ground approach beacon and from inner and outer marker beacons will allow the pilot to land under almost zero visibility.

Other aids which the R.A.A.F. are known to have and which will be included in the reserve training if the



W/Cdr. J. W. Redrop, Director of Telecommunications and Radar, R.A.A.F., who will organise the reserve.  
Photo: RAAF Official.

demand warrants, are radar beacons, high powered medium frequency homing beacons, cathode-ray D/F stations and the long range navigational aid Loran, which became prominent in the south-west Pacific during the war.

Although amateur radio offers some very interesting fields to conquer, these latest modern radio devices to be used by the R.A.A.F. will give the reservist an unending interest. V.H.F., one of the most interesting and perplexing subjects in radio, is to the fore, and the reservist will again be given the opportunity of studying this section of the spectrum.

## Amateurs' Equipment.

As yet no decision has been made with regard to the equipment to be used. In the pre-war days the amateur used his own station with crystals usually supplied by the R.A.A.F. From reliable information it is understood that the R.A.A.F. is preparing to make available communication equipment on loan to all reservists.

This reserve will be the most active of all service reserves in Australia. Whereas in most reserves it is only necessary to report annually or a change of address, this body will take a very active interest in its role. It will advance as electronics progresses.

# INTERNATIONAL RADIO DIGEST

## A Technical Survey of Latest Overseas Developments

### NEW MEASURING STANDARD

The usually accepted standard of length—the distance between two lines marked on a platinum iridium bar—is now likely to be replaced by an isotope standard. The new unit is the length of a wave of green radiation transmitted by mercury 198, an isotope transmuted from gold by neutron bombardment.



Adjusting the equipment for mercury 198 and cadmium wavelength comparison.

### Electronic Beetle Tracer.

The well-known Geiger-Muller counter, usually associated with atomic bombs, has now found a new peacetime application. A recently developed new form of G-M tube has been found extremely useful in studying the movements of the Elaterid beetles. As these beetles are known to fly but rarely in Britain, a study to the extent to which they move by walking is of considerable interest to the scientist.

A beetle is taken from the field, and 5 ugm or radium sulphate deposited between foil discs (2mm. in diameter and weighing only 0. mgm) is inserted with a resin adhesive beneath the elytra. The beetle is replaced and its position afterwards found by detecting the radiation from the disc with a G-M tube.

This new valve, which has the advantage of quiet background, stable operation and high sensitivity operates a loud speaker without any valve amplification, thus making it very convenient for field use. When it is passed over the region in which the beetle is thought to be, periodic ticks increase in frequency to a maximum when the tube is directly overhead.

Two lines traced on a bar are a rather crude instrument for precise measurements, and for this reason the red line of cadmium has been used for many years wherever extreme precision has been needed. However this latter standard has several disadvantages. Firstly, there is a fine structure in the red radiation which prevents the line from being as sharp as desired, and secondly, the cadmium standard requires furnace excitation, resulting in an unwanted broadening of the spectral line because of the relatively high temperatures.

The greenline of mercury 198 has none of these disadvantages, and possesses all the characteristics desirable in a light wave standard—such as absolute sharpness of the wavelength, intensity of the spectral line, and ease of maintenance.

### NEW LENS FOR RADIO RELAY SYSTEMS

The new type of metal lens developed by the Bell Telephone Laboratories for focussing radio waves in relay systems.

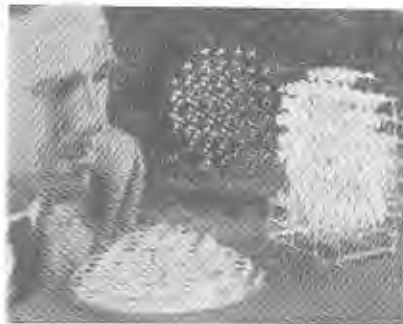

Theoretically capable of handling 50 to 100 television channels, the lens is based on the theory of light transmission through atomic and molecular structures and uses metallic spheres, discs or strips in a scaled up pattern similar to the arrangement of atoms in a crystalline molecule. The one in the rear uses metallic discs, lens in the foreground employs thin metallic discs mounted on a polystyrene foam, and model on the right uses metallic lens.

### INSULATOR AMPLIFIES CURRENT



A new method of controlling the flow and amplifications of electric current has been developed by physicists at Bell Telephone Laboratories. The method is based on the discovery that when beams of electrons are shot at an insulator—in this case a diamond chip—electric currents are produced in the insulator which may be as much as 500 times as large as the current in the original electron beam.

In bombarding the diamond chips with electrons, successive pulses of electrons lasting a millionth of a second are used instead of a steady stream of electrons. Energies of approximately 15,000 electron volts were employed.

It is considered that this discovery will have a great influence on the future design of electronic tubes as well as assisting in the study of the fundamental structure of solid matter under the impact of electrons.

### Photoelectric Ceilometers.

Many U.S.A. airports are now installing photoelectric ceilometers to record the altitude of cloud ceilings up to 10,000 feet. A beam of light thrown against the cloud base is reflected back to a photoelectric detector, placed a known distance from the projector. Altitude is found by triangulation, and the reading is recorded in a machine in the airport office. When used in the daytime the beam is modulated so as to enable the P.E. cell to distinguish it from daylight.

A "New" Receiver Design—

# The Caravan Five

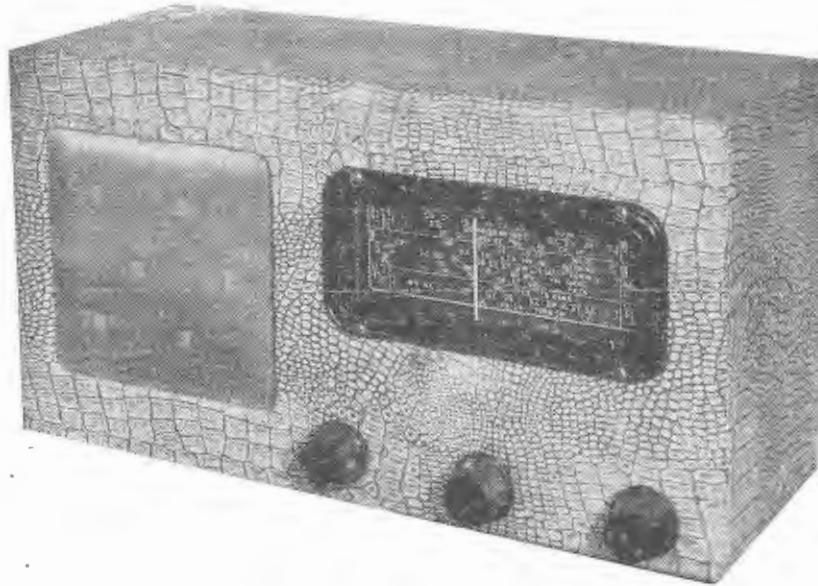

---

This high performance vibrator operated receiver has been specially designed for those applications where low current drain is an essential factor. Using four of the latest 1.4 volt miniature battery valves in conjunction with a 6V6-GT it combines this feature with excellent sensitivity, selectivity and ample power output thus making it eminently suitable for use in either a caravan or the country home.

---

Apparently the winter months are set aside by the owners of caravans as being just the time to overhaul the caravan and incorporate any new ideas in preparation for the coming summer days. This opinion is based on the large number of letters recently received from many readers for the description of a suitable receiver that can be easily fitted into such a unit.

As was to be expected each writer had his own ideas on the subject—some wanted a high degree of sensitivity, others portability and relatively high output, but in all cases the most important factor was that the set must have a low current drain. At the outset it was apparent that the receiver would have to be vibrator powered and consequently operate from a 6.0 volt storage battery.

## Choice of Valves.

This left the choice of suitable valves as the main major problem to be con-

sidered. In standard car practice, the qualifications of sensitivity and output requirements can be readily met by using the 6.3 volt series, but unfortunately the current drain is in the vicinity of 3 to 4 amps. Whilst this figure is not particularly excessive when used with a battery subjected to frequent charging by a generator, it does become a problem in a caravan or for that matter a home, where such charging facilities do not exist.

As regards current drain the 2.0 volt series offered the best solution to the problem. However, in this case, the output valve of the series—the 1D4 or its octal counterpart the 1L5-G—can only supply some 340 milliwatts with 135 volts on the plate. This is not particularly satisfactory if the set is to operate under outdoor conditions.

Then the question arose: why not use the 1.4 volt series in the RF section for

low current drain, and feed the output into, say, a standard AC output valve such as the 6V6GT. Although such an arrangement would, of course, increase the filament drain, it was considered that the overall advantages would outweigh this small point.

The final result of deliberations on the subject is shown in the schematic diagram, and it will be seen that four of the new 1.4 volt miniature valves have been used in conjunction with a 6V6GT output valve. For those who may wonder on the feasibility of the scheme we can only say that the set worked out just as planned and has been giving excellent results during the past month or so.

Under the conditions outlined, the 6V6G is operating with approximately 130 volts on the plate and screen, and this gives an output of slightly under one watt, more than enough for most cases, and cer-

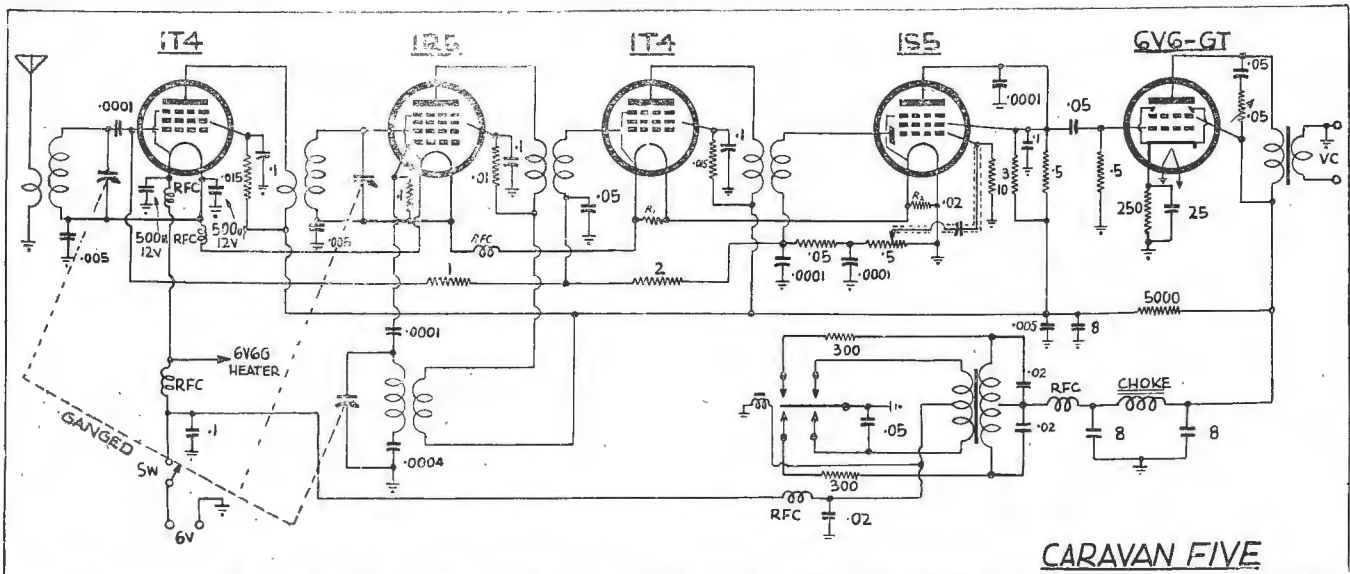

### CARAVAN FIVE

Using a combination of 1.4 volt valves and a 6V6-GT output valve this circuit is capable of excellent results. Particular care is necessary with the filament circuit, and this must be wired up as shown. The value of R1 and R2 is given in the text.

tainly much higher than obtainable from any comparable battery valve.

So much then for the general considerations and now to examine the circuit more closely. The valve line up is standard. The RF stage uses a 1T4, the converter is a 1R5, IF amplifier another 1T4, and a 1S5 combined detector and audio amplifier. The output from this is then taken to the 6V6G output stage.

#### Power Unit.

The power unit circuit is a standard arrangement and employs a synchronous type vibrator in conjunction with a Ferguson type 6V/150 Transformer. For an input of 6 volts this will give an output of 150 volts at 30 m.a.

The operation of this unit is briefly as follows: At the moment of switching on assume that the vibrating reed is touching the lower primary contact. With the input potentials as shown this will make the lower end of the primary winding negative with respect to the centre tap. Providing the transformer secondary winding are correctly phased, the lower end of the secondary winding will also be negative with respect to the high tension centre tap. However since this end of the winding is momentarily connected to earth by virtue of the vibrating reed, it follows that the centre tap must assume a positive potential.

As the reed travels in the direction to the other extreme of its travel, an opposite set of conditions will hold. Once again

#### PARTS LIST

- 1 Chassis
- 1 3 gang "H" Tuning Condenser (Midget Type)
- 1 Tuning Dial to suit
- 1 B/C Aerial, R.F. and Osc. Coil (Iron core "H" type)
- 2 455 kc. I.F. Transformers
- 1 Vibrator transformer—6 volt input, 150v @ 30 ma HT
- 1 Filter Choke
- 5 R.F. Chokes (Filament Type)
- 1 R.F. Choke (Pi-wound)
- 1 Vibrator Cartridge and socket

#### RESISTORS.

- 1 10 meg  $\frac{1}{2}$  w
- 1 3 meg  $\frac{1}{2}$  w
- 1 2 meg  $\frac{1}{2}$  w
- 1 .05 meg  $\frac{1}{2}$  watt
- 2 .015 meg  $\frac{1}{2}$  watt
- 1 .01 meg  $\frac{1}{2}$  watt
- 1 5000 ohm 1 watt
- 2 300 ohm  $\frac{1}{2}$  watt
- 1 250 ohm 3 watt wire wound
- 1 250 ohm  $\frac{1}{2}$  watt
- 1 200 ohm  $\frac{1}{2}$  watt
- 1 .5 meg potentiometer
- 1 .05 meg potentiometer

#### CONDENSERS.

- 2 500 mfd 12v. Electrolytic
- 1 25 mfd 25v. Electrolytic
- 3 8 mfd 525v. Electrolytic
- 4 .1 mfd tubular
- 4 .05 mfd tubular
- 4 .02 mfd tubular
- 3 .005 mfd tubular
- 1 .0004 mfd mica
- 5 .0001 mfd mica

#### VALVES.

- 2—1T4, 1—1R5, 1—1S5,
- 1—6V6-GT

#### SUNDRIES.

- 4 miniature sockets, 1 octal socket, 1 octal plug and socket, 2 terminals, 2 battery clips, bat-up wire, nuts and bolts, etc.
- tery cable, braided wire, hook-

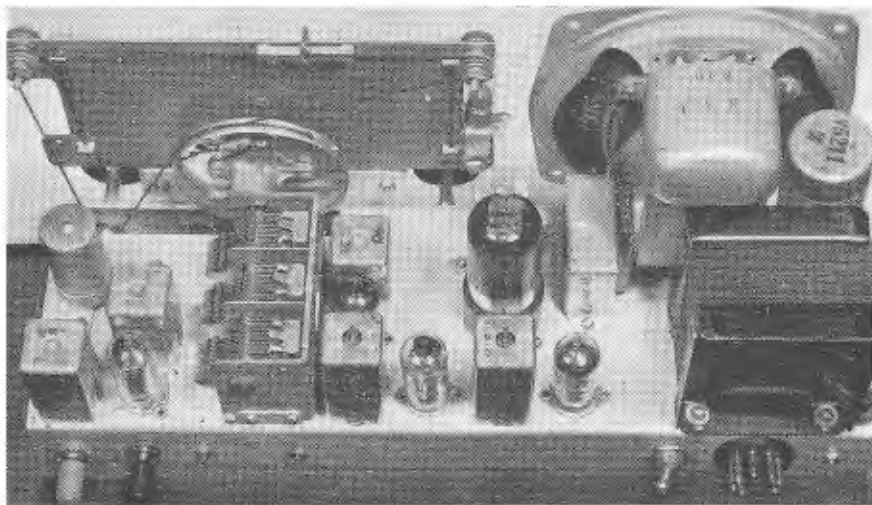

This top view of the completed receiver clearly shows the chassis layout. The tuning section is kept at one end of the chassis, with all power supply components mounted at the other end. This assists in minimising any vibrator interference.

the high tension secondary centre tap will be positive with respect to earth.

A little thought now will indicate the importance of correctly phasing either the input or high tension secondary leads to the vibrator cartridge. Unless this precaution is taken, one set of connections can easily result in a negative rather than a positive voltage at the high tension output.

If there is no exact guide given as to the correct connections they must be determined experimentally, preferably before the electrolytic condensers are connected into the circuit. The unit should be connected to a 6.0 volt source in the correct manner, and the d-c output checked with a suitable meter. If the high voltage is found to be negative with respect to chassis, it will be necessary to reverse either the primary or secondary leads—but not both. This is most important otherwise the filter condensers will act as a direct short circuit resulting in possible detrimental results to the vibrator cartridge.

**Buffer Condensers.**

The two "buffer" condensers connected across the secondary winding are very necessary, and their main purpose is to preserve a good output wave form. Whilst a single condenser in this position may suffice in some cases, better results are obtained by using separate condensers across each half of the winding. The value of these condensers is

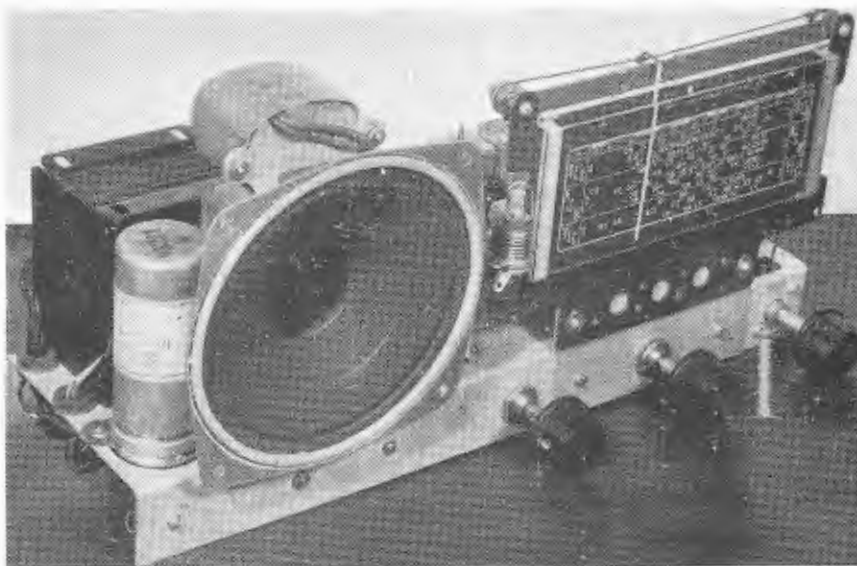

A front view of the completed receiver.

critical—0.01 to 0.02 mfd should be satisfactory and they must have a 1500 volt rating to withstand the AC peak currents.

The two series resistors shown connected in the secondary leads assist in reducing the RF "hash", and the values of these can be from 50 to 300 ohms.

**Filter System.**

The high voltage DC output is obtained from the centre tap of the secondary wind-

ing, and RF filtering is provided by the RF choke. In some cases it will probably be necessary to bypass this choke with 0.01 mfd condensers if there is trouble with "hash". Actually the value of these condensers is not particularly critical and can be the subject of some experimenting. The voltage rating should be 400 or 600 volt.

The RF choke is a standard type capable of passing the total set current, and

**KEEP ABREAST OF TECHNICAL RADIO DEVELOPMENTS!!**

Every issue of RADIO SCIENCE contains articles of interest to the  
 ● RADIO TECHNICIAN ● SERVICEMAN  
 ● EXPERIMENTER ● RADIO ENTHUSIAST

Make sure of receiving your copy by subscribing direct to the Publishers

Radio and Science Publications,  
 Box 5047, G.P.O. Sydney.

Please forward RADIO SCIENCE for.....months commencing with.....  
 issue. Remittance for.....is enclosed.

NAME.....

ADDRESS.....

CITY-STATE.....

OCCUPATION IN RADIO.....



**RATES: 12/- per annum; 21/- for two years. POST FREE**

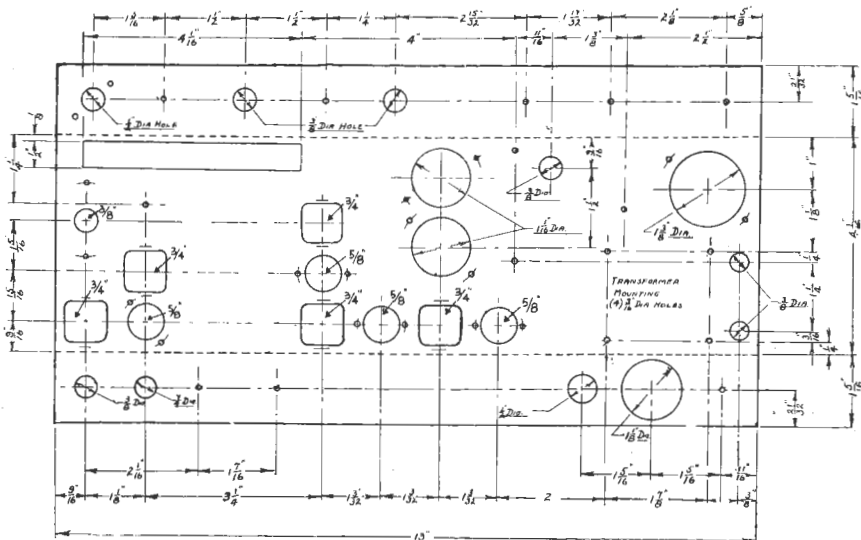

Use this working drawing as a guide when marking out the chassis.

for preference should be mounted as close as possible to the HT output point. The remainder of the filter circuit consists of a standard 6/60 filter choke with the two usual 8 mfd electrolytic condensers.

This system gives approximately 130 volts output, which is suitable for the 6V6G, but far too high for the 1.4 volt valves. Consequently a 5,000 ohm resistor is used in the HT line to reduce this voltage to the correct rating of 90 volts.

### Filament Wiring.

At first glance the filament wiring may appear unduly complicated, but if this is traced through is quite easy to follow. As can be seen the first four valves are very conveniently connected across the total filament supply. There was no necessity for a dropping resistor in this case since the input lead and RF chokes reduced the available voltage to approximately 5.8 volts.

To prevent RF interference in the filament circuits, they have been isolated by the use of RF chokes and usual bypass condensers. These chokes are the RCS type 86, with half the turns removed, to reduce the circuit resistance to a minimum, and are connected in the positions shown.

The two 500 mfd electrolytic condensers are necessary to prevent any modulation hum from reaching the filaments. The pulsating nature of the current drawn from the vibrator creates a ripple in the output from the battery and this is likely to give rise to the hum mentioned. The longer or higher the resistance of this input lead, the more pronounced this effect becomes, and the use of the 500 mfd condensers across the filament will help to minimise the trouble.

### Series Filament Problems.

When the filaments are connected in series as shown a number of problems arise that are not usually encountered with the more usual parallel arrangement. Firstly, the filaments become progressively higher in potential as they are removed from the earthed end of the circuit, and this, of course, gives rise to biasing troubles. If the grid returns should be returned to earth as is customary, then it will be found that instead of the valves operating with the required zero bias,

# **RADIO DEALERS and HOME ASSEMBLERS**

We have the finest range of Table, Console and Radiogram Cabinets in Sydney

## **Be Prepared for F.M.**

10.7 mc. I.F. Transformers available.

88 to 108 mc. Tuning Units available.

Watch for Constructional Details in this magazine shortly

# **SLADE'S RADIO PTY. LTD.**

'PHONE: UJ5381, UJ5382 :: :: LANG STREET, CROYDON, N.S.W.

Established over thirty years

there will be some negative value applied to the grid by virtue of the different potential at each negative filament pin.

To overcome this difficulty the 1R5 and 1T4 grid returns have been connected to the negative filament pin of the respective valve. In addition, the use of the shunt AVC on the 1T4 RF amplifier has in effect reduced the potential bias on this valve to practically zero volts. To provide an RF return it is necessary then to connect the .005 condensers to earth as shown.

The other problem encountered with such series networks is the effect of the various plate and screen currents. As can be realised the total cathode current for each valve must pass through the negative side of the filament, which means that the valves nearer the earthed end of the system—in particular, the 1T4-IF amplifier and 1S5 detector must carry the whole cathode current of the other valves.

Consequently, in order to prevent incorrect filament voltages it is necessary to provide a shunt resistor across each of these valves. Since the manufacturing tolerances of these valves allow a variation of  $\pm 10$  per cent. in operating ratings, the exact value of the resistor required can best be found by experiment. As a guide, in this receiver it was found that a 200 ohm resistor across the 1T4 and a 250 ohm resistor across the 1S5 proved generally satisfactory. Although in theory another shunt resistor should be placed across the 1R5 filament, this was not deemed necessary in view of the large tolerance values allowed and low ratio of total valve current to filament current.

The remainder of the circuit is quite standard and should not require any explanation. Under the conditions shown, the 6V6G will provide an output slightly

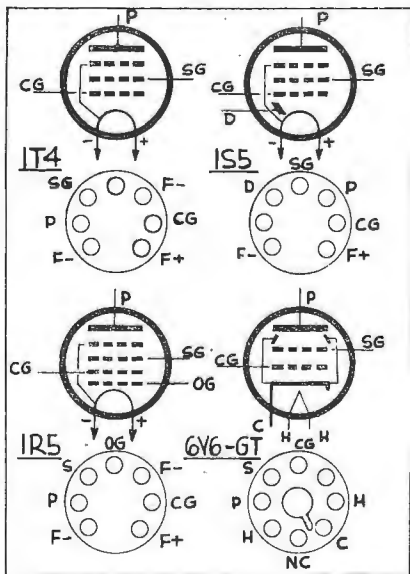

Here are the socket connections for the valves. In each case the socket is viewed from underneath.

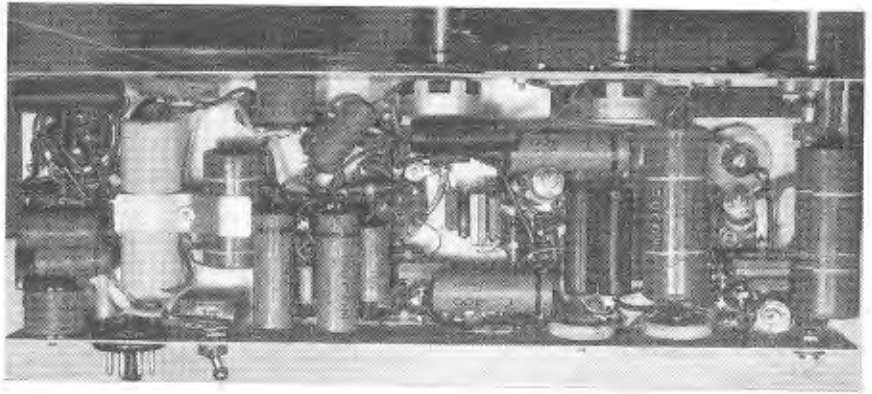

This underneath chassis photograph shows how the various components were fitted in.

under 1 watt. The grid bias voltage is  $-5$  and the output transformer impedance should be approximately 6,000 ohms.

A tone control circuit—consisting of the .05 mfd condenser and .05 meg potentiometer—is connected across the output circuit, and will provide satisfactory results.

### General Construction.

Although a ready-cut chassis (as well as an attractive cabinet) should soon be available for this receiver, the full chassis dimensions are included for those who may wish to start on the job right away. The general layout and location of most components can be readily seen from the accompanying photographs, and the necessity for short direct leads cannot be over-emphasised.

In a receiver of this type much of the likely final troubles is due to vibrator *hash*, and to overcome this problem it is necessary to take the greatest care during construction with the layout and wiring up of the many components. To reduce the interference, it will be seen that the vibrator unit has been mounted at the extreme end of the narrow chassis, with the RF section at the other end.

The aerial input lead to the aerial coil terminal is very short and if necessary this may be shielded. The earth connection is essential and should always be used with this type of set. The only other lead likely to cause any trouble is the one from the 6V6 plate to the speaker transformer. Unless this is correctly installed it will pass very close to the coupling condenser (from 1S5 plate to 6V6G grid) and consequently result in feedback in the form of hiss and a high pitched whistle.

Both leads from the accumulator should be shielded and the metal braid then earthed only to the case of the vibrator supply. Whilst it may at first glance seem pointless to shield a lead already at earth potential, it must be remembered that this lead is really carrying vibrator current with superimposed transients and consequently can still actually radiate a certain amount of interference. The

cover of the input plug should also be earthed to the same point and for preference this connection should be made with braided wire.

### Alignment.

Once the receiver has been completed the next step is to align the tuned circuits for maximum results. Whilst this procedure has been detailed in previous issues, it is given once again for completeness.

Although this should be done with a modulated oscillator to achieve maximum results, the following simplified procedure will generally be satisfactory in most cases.

Tune in a station at the high frequency end of the band and adjust the aerial trimmer for maximum gain. Next tune to the low frequency end and adjust the aerial slug for maximum results. At this stage loosen off the dial drum and adjust the dial pointer to register correctly on a station, such as 2FC.

Then tune in station 2SM on the high frequency end and adjust the oscillator trimmer until this is shown to be in its correct position. Again check the aerial trimmer for maximum output, and if your gang, coils, and dial are accurately matched then all the stations should come in at their marked positions.

Unless you have a modulated oscillator it is preferable not to touch the I.F. tuning slugs, although it is permissible to move the slugs (starting from the secondary of the last I.F. and working backwards), slightly one way or the other to check for maximum output.

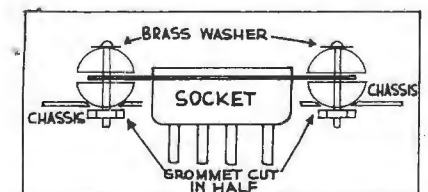

To minimise interference problems, mount the vibrator socket on rubber grommets as shown.

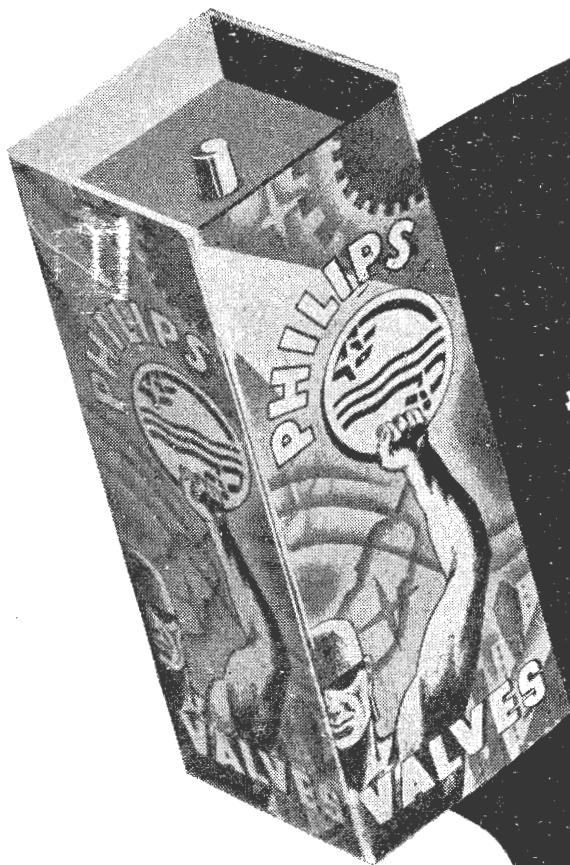

Don't get  
the wrong idea



**A**S you've noticed, Philips Valves are now appearing in the smart new blue and yellow cartons . . . or at least *some* of them are. The change-over is being made gradually, due to the fact that considerable stocks of the old-type cartons must be used first. There is an acute shortage of carton board, and to scrap all old stocks would be inexcusable waste.

Although, for some time, you will receive your supplies of Philips Valves in both new and old cartons, *each and every valve is straight from the assembly line.* Old cartons for a time . . . yes! But the valves inside . . . *as new as the minute.*



# PHILIPS VALVES

PHILIPS ELECTRICAL INDUSTRIES OF AUSTRALIA PTY. LTD.

SYDNEY • MELBOURNE • ADELAIDE • PERTH • BRISBANE

V10



# MAGNETIC STRING MUSIC PICKUP

Details of an easily constructed magnetic pickup unit, which can be added to any guitar or other stringed instrument.

This guitar pickup reproduces faithfully the sound of any steel-stringed instrument. It is held to the instrument by suction cups, and can be attached or taken off readily. Since it depends on the magnetic principle and not on sound vibrations, the quality of reproduction does not depend on the original instrument.

## Type of Magnet Used.

The unit is built around a piece of Alnico V magnet—the size used being  $\frac{3}{16} \times \frac{5}{16} \times 2\frac{3}{8}$  inches. This was pre-magnetized and polished on one narrow face.

The length of the magnet is important since it must span the strings of the instrument. This  $2\frac{3}{8}$  inch length is suitable for a 6-string guitar; for a tenor guitar, which uses only four strings, a shorter magnet would be better.

The magnet in this case was magnetized longitudinally. While this caused some attenuation of the two middle (D and G) strings, it had the desirable result of building up the strength of the tones produced by the outside ones. Since the melody is usually carried by the two highest (B and E) strings, this was quite satisfactory; and some unusual effects in bass runs may be achieved by this build-up in bass response. If it is possible for the builder to obtain a magnet which is magnetized across the  $\frac{3}{16}$  inch face, some other interesting results might be achieved.

## Constructing the Coil.

The coil form of thin fibre is glued with coil cement and made to fit the

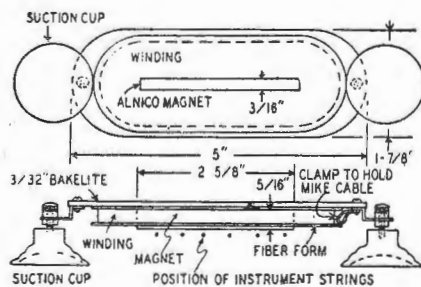

Full constructional details are given in this diagram.

magnet slug used. Dimensions of the original unit appear in Fig. 1. When this form has dried, remove the magnet and replace it with a small piece of wood or bakelite drilled in the centre to accommodate a 1-inch 6-32 machine screw. By chucking this assembly in a hand drill it is easy to wind the wire. The coil form is scramble-wound with No. 32 enamelled wire. Two short lengths of flexible wire are soldered to the ends of the wiring to facilitate making connections.

This winding has a d.c. resistance of approximately 30 ohms. The output will be greater if the builder can wind on more turns of smaller wire. However, it is difficult to wind wire smaller than No. 36, unless special care is exercised.

## Assembly Details.

The completed coil and magnet assembly is glued to a  $\frac{3}{32}$ -inch bakelite or fibre mounting plate. The flexible wires soldered to the winding should now be soldered to the microphone cable, the outside end of the winding going to the shield of the cable. A cable clamp attached to one of the 8-32 screws on the suction cups holds the cable to the assembly. The other end of the cable terminates in a standard phone plug, connected so that the shield will go to ground in the amplifier used. The inner conductor of the cable may be inserted directly into the grid circuit since the impedance of the winding is sufficiently highly.

The suction cups holding the unit to the sounding board of the instrument are then attached to the mounting plate with small brackets. The height of these brackets will depend upon the size of the suction cups used, allowance being made for the fact that compressing the cups will lower the assembly considerably. The unit should be as close to the strings as possible without touching them. The exact height can be adjusted by the two nuts on the bolts which hold the suction cups.

## The Instrument Amplifier

The amplifier need not be an elaborate one. A high-fidelity type is prefer-

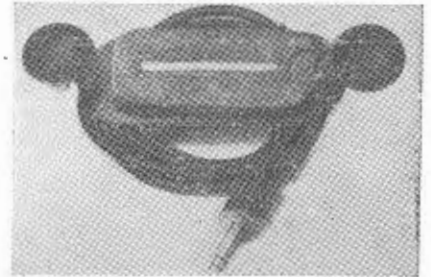

A view of the completed instrument.

able, but almost any 2-stage voltage amplifier with a single output tube will do. This unit has also been used with excellent results with a phono oscillator having an extra voltage amplifier ahead of the modulator.

This pickup was tested on both Hawaiian- and Spanish type guitars. It does not alter the characteristics of rendition. Since the Spanish guitar is essentially a rhythm instrument, the pickup should reproduce a not too sustained tone. When using a steel guitar, a sustained tone is desired and a short, snappy tone would not be suitable. This pickup fulfils those qualifications.

The experimenter can build this little gadget at nominal cost. It will electrify almost any guitar and (with a few changes) many other instruments. It may be used with any amplifier used for music amplification.

—Courtesy Radio Craft.

## FM Broadcast Interference.

The interference to British television programmes from American FM stations have now become so severe that many of the latter station schedules have had to be changed.

This interference, previously considered unlikely because of the line-of-sight propagation characteristics of the v-h-f waves, is caused by long range skip transmission from the 45.1 Mc. transmitter. It is thought that this is only a temporary condition brought about by sunspot activity—now at the highest point ever recorded, and will not recur as a serious problem at such long distances until the next sunspot maximum.



A.—Applying liquid wax to heated glass disc.

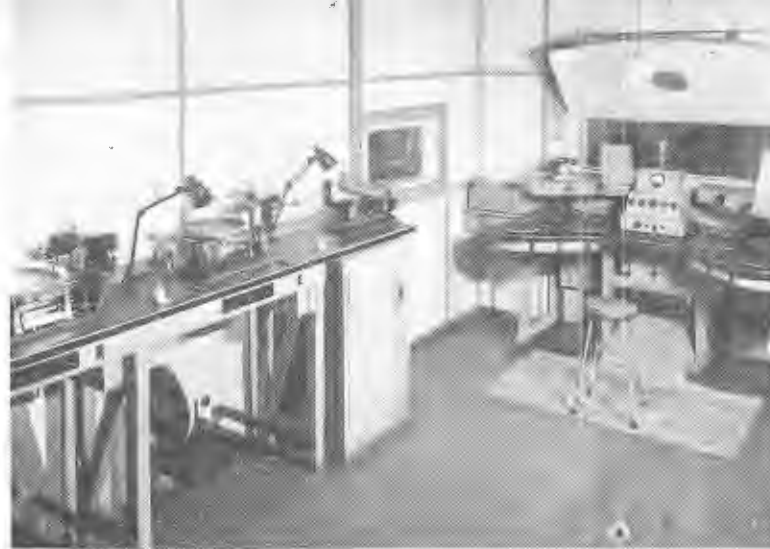

B.—The No. 1 Control Room.



C.—Immersing cut wax disc in electrolyte.



D.—The negative "shell" is carefully stripped from the wax.

## RECORDS IN THE MAKING

Modern recording practice dates from 1925, when electrical recording made it possible to record almost anything successfully. The accompanying photographs depict some phases of modern methods of making records—the use of which has now become an integral part of the modern home.

The first stage in the manufacture of a record is in the preparation of the wax disc on which are cut grooves corresponding to the received sound waves. A new method of preparing these wax blanks has been perfected. This consists of using highly finished plate glass discs, which when heated to a suitable temperature are coated with a thin film of specially prepared recording wax. (A) The even flow of this wax over the glass is carefully controlled in an air-conditioned chamber, and the plate is then gradually cooled until the hardened wax provides a perfect mirror-like surface.

As soon as the recorded wax has been received from the studio (B), it is prepared for electroplating by dusting the surface with a graphite powder so fine that it does not affect the delicate sound tracks. This conducting surface allows the particles of copper in the plating bath to form a thin but strong "negative" shell on the wax (C). The removal of this shell calls for very great skill and experience since in the process of stripping it off, the wax itself is rendered useless (D).

The first copper shell is called the "Master" and instead of grooves in its surface, it bears the sound waves from the wax in the form of ridges. Although records could be pressed at once with it, the "Master" would begin to wear after a limited time. So a second copper shell called the "Mother" is now grown on the "Master" (E). This is again positive and of no use for pressing records. The "Mother" is therefore put back into the plating bath and a third and final shell deposited. This is known as the "Stamper Matrix" and these can be taken from the "Mother" as often as required.

The "Stamper Matrix" is now backed with a copper plate and the

centre hole drilled. Sample records are pressed from it, and these undergo various tests for wear, musical quality, etc., before the record goes into production.

The pressed record is actually laminated, consisting of a centre core and two surface sheets of sulphite paper specially coated with a shellac compound (F). This form of manufacture not only gives considerable strength to the record but provides a smoother playing surface. The core material consists of shellac, copal mineral earths which form a black substance that becomes plastic when hot and hard at normal temperatures.

It is mixed in machines which reject automatically any gritty particles, and the refined material is passed through heated rollers which grade it to a uniform thickness and mark the sheets into suitable sizes for 10 and 12 inch records respectively. When the sheet becomes cold and hardens, these pieces of material are broken off and referred to as "biscuit."

The "biscuit" is taken on trolleys to the press room (H) where the press man has already fixed two matrices ready in position to make a double-sided record. In the centre of each matrix he places the requisite label followed by the specially treated surface material or coated paper sheet (G). From the heated slab by the press he takes one of the pieces of "biscuit", rolls it into a ball and puts it on the centre of the lower matrix.

He then pulls a lever and the hinged plate bearing the matrices close with a pressure totalling nearly 100 tons to the square inch. As the pressure is applied steam is circulated behind the matrices and this is followed by water cooling. The press then opens revealing one of the familiar black shining discs (I). It is taken off from the press and the surplus material broken from the edges.

Nothing now remains but the finishing process of buffing the edges (J), polishing the disc (K), affixing any Copyright Royalty Seals and a final inspection before packing and passing along to the store. As a check on the production, records are taken from each batch of pressings at regular intervals and tested for wear.

Photographs Courtesy: The Gramophone Co. Ltd., Columbia Graphophone (Aust.) Pty. Ltd., and Parlophone Co. Ltd.



K.—The final polish before inspection and packing.

RADIO SCIENCE, June, 1948

J.—Buffing the edges of the finished record.

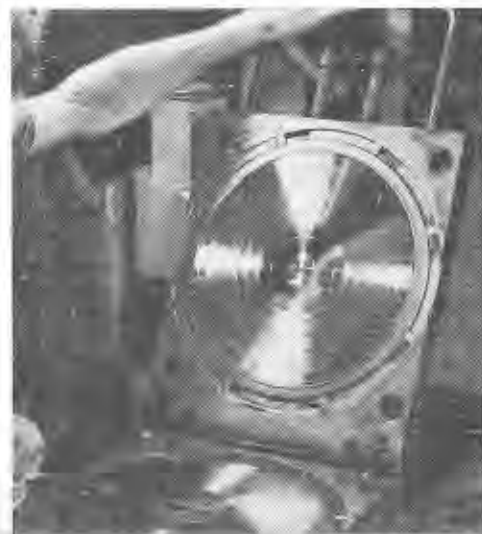

I.—The pressing completed.

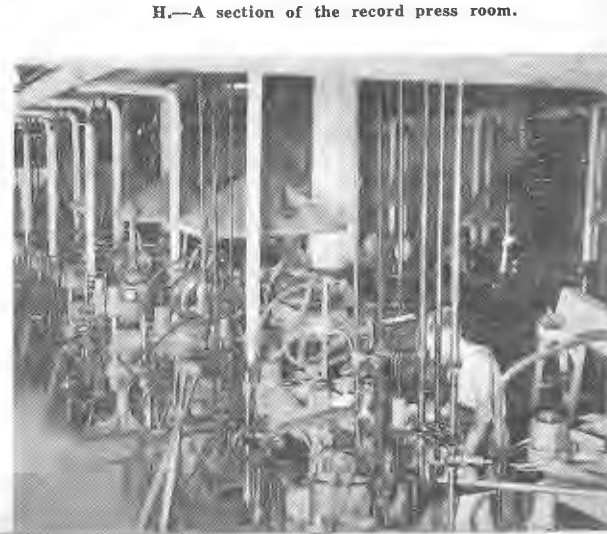

H.—A section of the record press room.

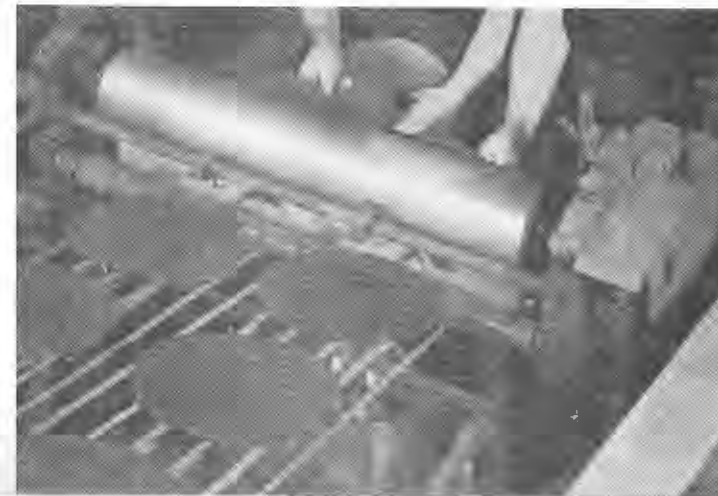

G.—Coating the surface sheets with a shellac compound.



E.—The negative "Mother" is again immersed and a positive "Mother" grown.

RADIO SCIENCE, June, 1948

F.—Stripping the "Mother" from the "Master" negative



# RADIO SCIENCE

This is the fifth in our series of Radio Quizzes to test your general and technical radio knowledge. To obtain your I.Q. rating, take 10 points for each question you answer correctly, and 5 points if only half right.

As a guide to your ability, the scores are: Beginner, 50% and under; Experimenters and Servicemen, 50 to 75%; Experts, 75 to 95%; and Genius, over 95%.

*Q.1.—The number of Kennelly-Heaviside layers is—*

- (a) One.
- (b) Two.
- (c) Three.

*Q.2.—Technically speaking a radio wave is a—"disturbance propagated through a dielectric or free space having the nature of a travelling magnetic field at right angles to it." Whether you knew this or not, you should still be able to pick this one. What kind of waves can be transmitted through pipes?*

- (a) Ultra short.
- (b) Standard Broadcast.
- (c) Long waves.
- (d) Centimetre waves.

*Q.3.—Monel metal, which is an alloy sometimes used in the construction of condenser plates and chasses, is composed of—*

- (a) Copper, nickel and iron.
- (b) Copper, nickel and silver.
- (c) Zinc and lead.
- (d) Nickel, brass and platinum.

*Q.4.—If you intended using a double button microphone for one of those "actuality" home broadcasts, which would be the best way to connect it into your receiver?*

- (a) Directly across the grid and cathode of the first audio amplifier valve.
- (b) To the grid and cathode of the detector valve through a special coupling transformer.
- (c) To the grid and cathode of the first audio amplifier through a special coupling transformer.
- (d) Directly across the grid and cathode of the detector valve.

*Q.5.—A general purpose triode is a very useful valve and can be used for many*

*circuit applications. It is usual to connect the plate and grid together when it is being used as—*

- (a) An RF amplifier.
- (b) A modulator.
- (c) A half wave rectifier.
- (d) An AF amplifier.
- (e) A beat frequency oscillator.

*Q.6.—Although most receivers nowadays only require an indoor antenna for efficient operation, there are still many who prefer to hook up the impressive outdoor type, if only to impress the neighbours. Which brings us to our question. Why is stranded enamelled wire preferred by many for the outdoor antenna?*

- (a) It does not corrode so rapidly.
- (b) It offers a greater surface area.
- (c) It looks better.
- (d) It is cheaper and lasts longer.

*Q.7.—Now one to give you a few extra marks. Which of the following electrical appliances is the most efficient?*

- (a) Electric motor.
- (b) Generator.
- (c) Electric light bulb.
- (d) Transformer.

*Q.8.—The simplest form of electrical condenser consists of a pair of conducting surfaces separated by—*

- (a) A dissimilar metal.
- (b) An insulator.
- (c) A low resistance.
- (d) A voltage divider network.

*Q.9.—Circular mils are—*

- (a) Places where logs are sliced into boards.
- (b) Limits expressing the cross-sectional area of wires.
- (c) A set of mathematical tables used in spherical trigonometry.

*Q.10.—Frequently the occasion rises when it is necessary to change a wavelength in metres to the equivalent in feet. The simplest way of doing this is to—*

- (a) Multiply the number of metres by 36.
- (b) Divide the number of metres by 36.
- (c) Multiply the number of metres by 3.28.
- (d) Divide the number of metres by 3.28.
- (e) Multiply the number of metres by 6.28.
- (f) Divide the number of metres by 6.28.

*Q.11.—The word "broadcasting" occurs fairly frequently in radio publications and the term really means—*

- (a) Any transmission of radio energy from a transmitting station.
- (b) Transmission of entertainment programmes.
- (c) Transmission directed at no particular area.

*Q.12.—As most readers know, the control grid in many screen grid valves is brought out through a metal cap at the top of the valve. The purpose of this is—*

- (a) To make shorter grid leads possible.
- (b) So that the meter can be readily connected when measuring voltages.
- (c) To keep the grid lead inside the valve away from the rest of the valves internal leads.
- (d) To make it easier to connect and disconnect the grid lead.

*Q.13.—If you have happened to read the recent article on "FM Antenna Transmission Lines," this one should be easy. The most efficient means of transmitting high frequencies by a wire line is—*

- (a) Twisted pair.
- (b) Co-axial cable.
- (c) Shielded wire inside ground shield.
- (d) Widely separated single wires.
- (e) Transposed lines.

*Q.14.—The radio compass as fitted to most aircraft and ships is a very useful device. However you would be wrong if you said that it is—*

- (a) A compass used by surveyors to determine a suitable location for a transmitter.
- (b) A loop antenna operated to determine the craft's direction from a transmitter.
- (c) A compass which is corrected by means of a radio beam.
- (d) A means of determining the position of the plane or ship through triangulation.

*Q.15.—Now for a simple question involving circuit theory. If a number of valve filaments are connected in series across a common voltage source and one of them burns out, the remainder will—*

- (a) Become brighter due to decreased resistance in circuit.
- (b) Immediately go out.
- (c) Remain alight, but become dimmer.

(For answers see page 48.)

Completing The—

# ALL-WAVE BATTERY TWO

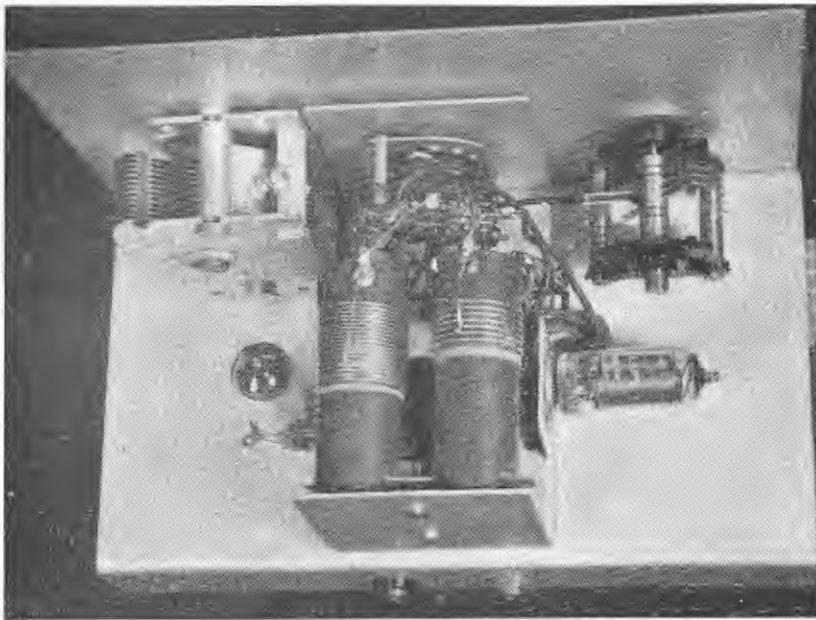

A view of the chassis showing the two short wave coils mounted in position.

The addition of two easily constructed short wave coils is all that is necessary to complete this small receiver. The accompanying article gives full details of these coils, together with the method of operating the receiver on these higher frequencies.

In the previous issue, the general chassis details as well as the wiring in of the broadcast coil were given for this small receiver. No doubt many of those who have started to construct the receiver are now in a position to add the two short wave coils, and full details of these are now given.

Whilst the addition of these extra coils is not a particularly difficult task, it will be found that more care is necessary than was the case with the broadcast version, if the set is to operate with maximum efficiency.

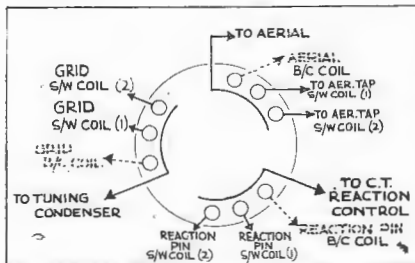

Use this diagram as a guide when connecting the coil leads to the wave change switch.

Before detailing the winding of the two short wave coils, there is one further point in regard to the circuit that requires mention. Reference to the schematic diagram will show that there are two variable condensers connected across the coils. One of these is the main tuning condenser—referred to as the *band-setting* condenser and the other is a 5 plate mid-get type, sometimes known as the *band-spread* condenser.

## Band Spread Condenser.

The purpose of this small condenser is to enable a small section of the total tuning range to be *expanded* or widened and so facilitate the tuning in of these short wave stations. Due to the higher frequencies involved, it will be readily realised that a small movement of the main tuning condenser will cover a wider band of frequencies on either coil, than would be the case with the broadcast band coil. This means the actual space occupied by any particular station is extremely narrow, and consequently greater care must be observed with the movement of

this condenser to accurately tune in a given station.

This difficulty, fortunately can be simplified by the addition of the band spreading arrangement. As before the required frequency band is tuned in the normal manner using the *band-setting* condenser and then by means of the smaller condenser this can be *spread* over the full movement of the condenser. So in effect the actual band width is effectively increased resulting in easier logging of stations.

## Winding the Coils.

The coil data for the two coils is indicated in the accompanying diagram and panel, and this should be adhered to for a start. However, at this juncture it should be pointed out that since it is practically impossible to exactly duplicate hand wound coils, the constructor will most likely find that some slight modifications to this data are necessary if maximum results on each band are to be achieved. For this reason the data given should be merely regarded as a sound working basis from which any changes can be made.

The coil formers used are 7/8-inch bakelite tubing, and 2½ inches long. The various coil lead terminals are made by attaching ordinary solder lugs to the end of the coil by means of small eyelet rivets. The other end is slotted as indicated by using a hacksaw and the aluminium mounting strip slides into this groove.

Although there are several ways of

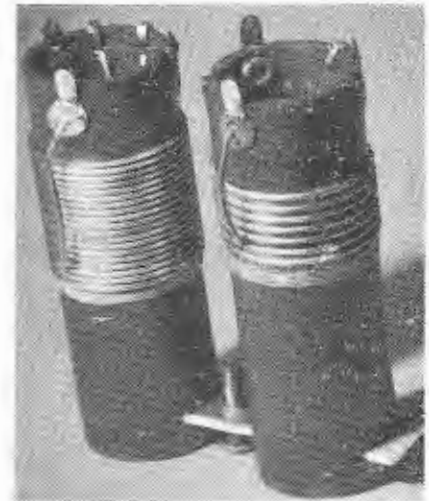

A close up of the two completed coils. Note method of fitting the mounting strip.

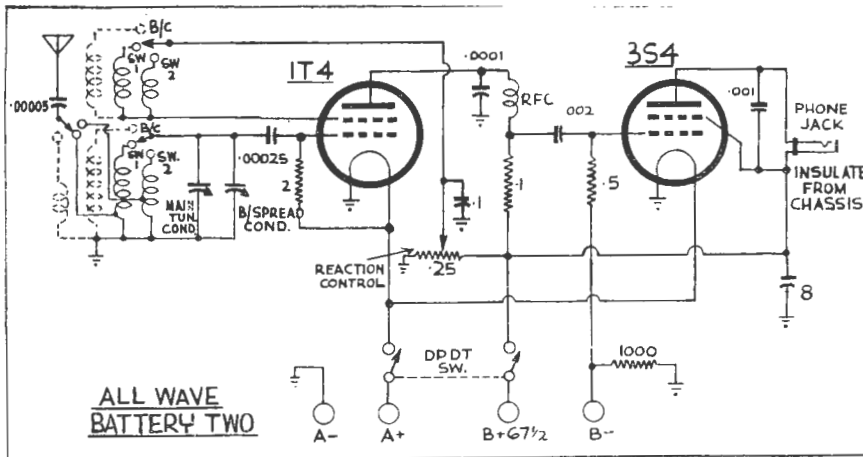

The circuit is basically the same as that used for broadcast version, with the addition of the short wave coils.

winding the coils, it is considered the following is probably the simplest method. First of all solder one end of the wire (always start with the grid winding) to the requisite terminal lug after threading the wire through a hole drilled in the coil form. Then secure the loose end of the wire to some convenient distant point. Wind the coil by keeping the wire taut at the same time moving towards the distant end of the wire as the coil former is being turned in the hand.

Whilst this may seem somewhat crude, it will be found that this method will

allow the wire to be wound more tightly, resulting in a better looking coil, than would be the case if the former is simply held in the hand and the wire wrapped around it. When the correct number of turns have been wound on the tubing, cut the wire, thread it through another hole drilled in the former and solder direct to one of the terminal lugs.

As tinned copper wire is used for the grid winding, it is a simple matter to solder the separate tap lead in position after the coil is completed.

The reaction winding is wound with

No. 30 SWG silk covered wire and this should be inter-wound at the cold end of the grid winding as shown. When both windings are completed, cover them with a coil dope solution to prevent any movement of the turns.

The important point to watch in winding the coils is that the wire is kept as tight as possible at all times. The spacing between the various turns can be either judged by eye, or better still string of the same diameter as the wire can be wound on at the same time between the turns, and then removed as soon as the coil ends are soldered in position.

When the coils are completed, mount them in the position indicated—immediately above the broadcast coil, and connect the various leads to the switch. The small diagram will assist in doing this, and to avoid any possible errors it is suggested that all leads on any one coil be soldered in place before starting on the second coil.

### Operating the Set.

When the coils are wired in position, and all leads re-checked for possible errors, switch the set ON and turn the wave change switch to the desired band. It should be mentioned that Short Wave stations are not on the air at all times, and consequently reference should be made to current short wave notes before trying for any particular station.

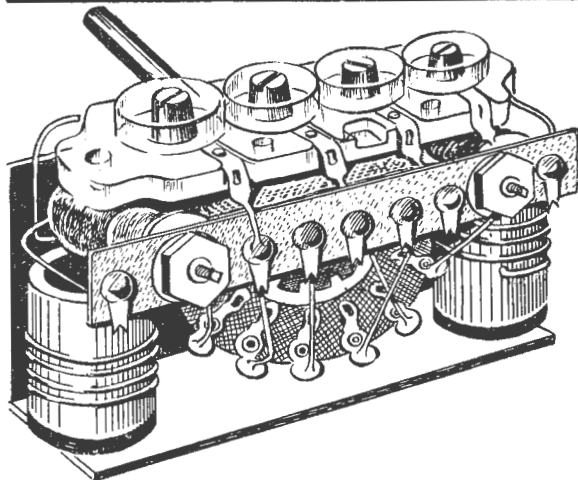

## Making a Midget?

Make it **DUAL WAVE** with the Special "Q PLUS" IR5 Bracket

"Q PLUS" is the smallest yet.

No Half Measures with "Q PLUS"

"Q PLUS" has Full Size Short Wave Coils— with Full Performance "Ferropreg" B/C Coils

Insist on "Q PLUS" Coils

## 'Restling with a Reinartz?

NOW Available: The New "Q PLUS" Midget

Permeability Tuned REINARTZ Coil

Complete with Recommended Circuits, etc.

**R. W. STEANE & CO. PTY. LTD., Auburn, Vic.**

Trade Enquiries Direct or to A. J. PHILLIPS AGENCIES, 27 Hunter Street, Sydney — Brisbane — Adelaide.

Factory Representative (New Zealand): MESSRS. CARREL & CARREL, 41 Shortland Street, Auckland, N.Z.

Please Mention RADIO SCIENCE when Replying to Advertisements.

Next, advance the regeneration control in a clock-wise direction until the familiar sound of the set oscillating is heard. This condition can be readily recognised by a rushing or hissing noise, and the point where this oscillation begins is the most sensitive operating point for the receiver at that particular band setting.

The tuning dial—that is the *band-setting* condenser should now be slowly turned, and at the same time keep moving the regeneration control in order to keep the set oscillating over the range. If the tuning is done slowly and carefully, it should be possible to hear some type of stations—either phone or code. Backing off the regeneration control until just below the point of oscillation will allow the phone station to come in clearly, whilst for the reception of code signals the receiver can be left in an oscillating condition. The tone of the code station will depend on the frequency produced by *beating* the detector against the incoming signal frequency, and consequently may be varied within slight limits by adjusting the tuning condenser.

As mentioned last month, the presence of a station will be indicated by a *whistle* and once this is heard, leave the tuning condenser set, and use the bandspread condenser as a *vernier* control for the final tuning in.

### Careful Tuning Necessary

The main point to bear in mind is the necessity for careful tuning on all short wave bands otherwise many stations will be easily passed over. However, a little practice with the set will soon make the beginner quite proficient at station logging.

### COIL DATA.

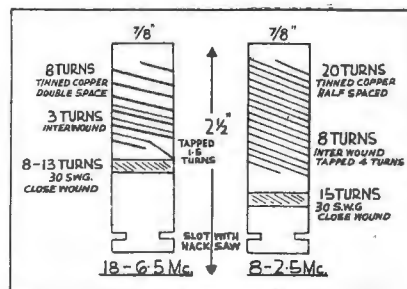

### GRID WINDING.

18-6.5 Mc  
8 turns 18g. Tinned Copper Wire. Double Spaced. Winding occupies  $\frac{1}{2}$ in. Tap 1.5 turns from cold end.

8-2.5 Mc.  
20 turns 18g. Tinned Copper Wire.  $\frac{1}{2}$  spaced Winding occupies  $\frac{7}{8}$ in. Tap 4 turns from cold end.

### REACTION WINDING.

18-6.5 Mc.  
8-13 turns 30SWG SC wire. 3 turns interwound with cold end of grid winding then balance close wound.

8 2.5 Mc.  
15 turns No. 30 SWG SC wire. 8 turns interwound with cold end of grid winding. Balance close wound.

For reference, the various dial markings for the different bands should be marked on the front panel as soon as they are located, and this will enable easy recognition at a later date. By careful tuning coil 1 will cover from 18 to 7.5 Mc—approximately 16.5 to 46 metres, and consequently you should be able to hear stations on the 19, 25, 31 and 42 metre bands, as well as the 20 and 40 metre amateur bands. The second coil provides

(Continued on page 48.)

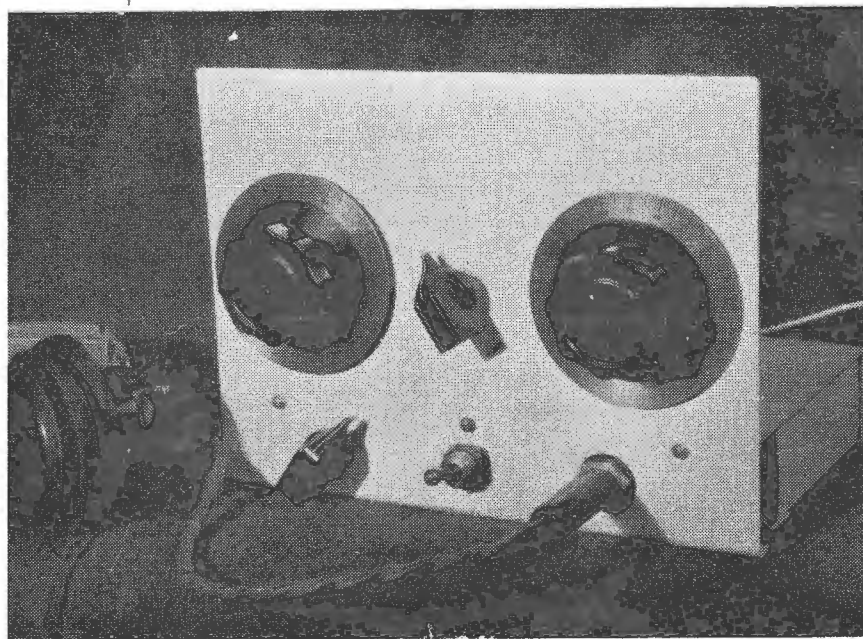

A front view of the completed receiver. If desired the set can be easily fitted into a small wooden cabinet.

# "CONNISEUR"

crystal pick-ups

A superb unbreakable crystal pick-up guaranteed for twelve months. Designed for minimum record wear and full tonal brilliance. Equipped with the exclusive needles made by the AUSTRALIAN RECORD COMPANY of SYDNEY, either sapphire or standard needles.



### THE PICK-UP FOR YOU

An attractive technical brochure is available on request so we advise you to write today, to the SOLE MANUFACTURERS of the Australian CONNISEUR.



# KELMAN INDUSTRIES

Department RS.

Box 40

Hawthorn, E.2.

MELBOURNE, VICTORIA.

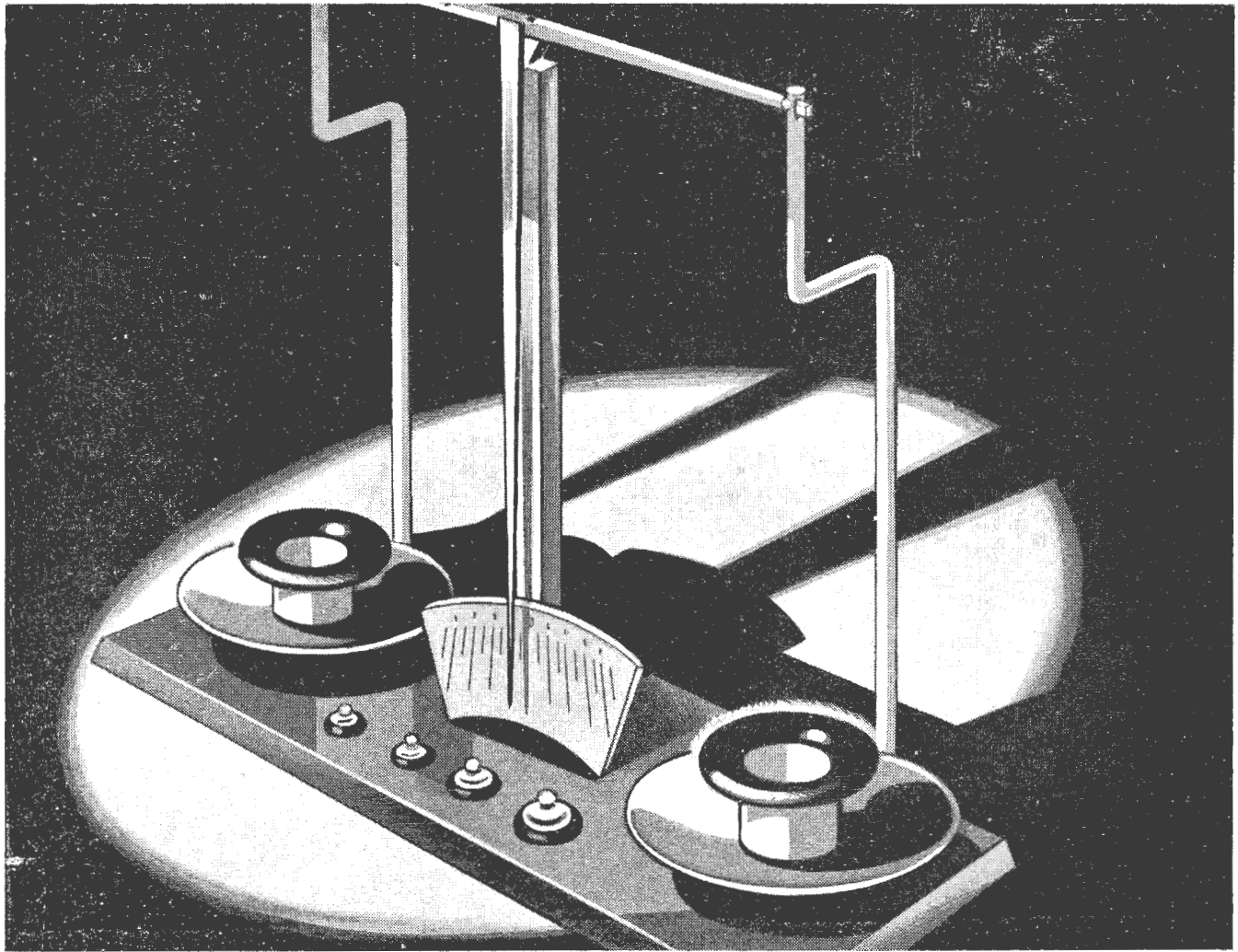

## NO TWO 'WEIGHS' ABOUT IT — THEY'RE IDENTICAL

That is just a way of drawing your attention to a particular feature we are proud of at Eyelets. Every metal pressing from the first to the last of the order . . . and sometimes there are millions of pressings . . . is absolutely identical and absolutely right to specifications. You can always depend on Eyelets for accuracy, low production cost and prompt delivery. Your output will never be held up through any fault at Eyelets. New pressings to suit your specific need

. . . specifications as requested . . . and these are great advantages . . . or as we say at Eyelets, tremendous trifles. Why not get in touch with us?

**EYELETS**  
**PTY. LTD.**

GREEN STREET, WINDSOR, MELBOURNE  
 Interstate Representatives: C. H. R. JOHNSTON PTY. LTD., Sydney; F. L. RUNGIE, Adelaide; E. D. WELSH, Brisbane; C. R. PALMER, Perth

PATON

# FOR THE EXPERIMENTER

By A. H. NICHOLLS, VK2NI

## Battery Powered Signal Generator.

A simple signal generator for receiver alignment can be made up using the following circuit. Requiring a minimum of parts the whole unit can be completed in an evening. Being operated from batteries, the unit is self-contained and portable.

The coil details are as follows:—  
L1.—150 turns tapped at 50 turns from grid end  $1\frac{1}{2}$  in. former.  
L2.—48 turns tapped 18 turns from grid end  $1\frac{1}{2}$  in. former.

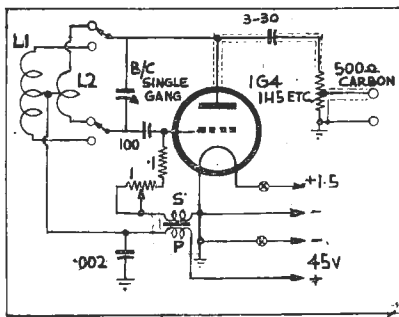

The battery-operated signal generator circuit. Any of the 1.4 volt triodes may be used in this circuit.

## Switch to Safety.

For the sake of a few shillings why take the risk of putting the "test finger" inside the rig?

The circuit below is a definite life saver in this respect and in addition, acts as an HT "on-off" indicator. A double pole double throw relay and two lamps is all that is required.

The two resistors shown in diagram prevent any inductive surges from blowing the pilot lamps.

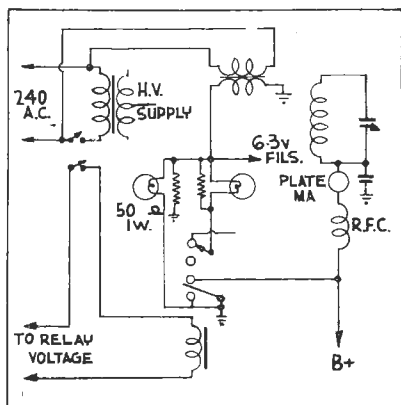

This relay operated power supply will ensure "safety" in the transmitter as well as acting as a visual "ON-OFF" indicator.

## Crystal Mixer in V.H.F. Converter.

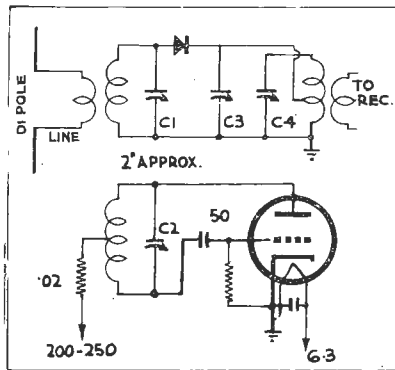

Crystal mixer circuit for a VHF converter. C1 is a 3 plate variable; C2, a 5 plate air trimmer; C3 and C4, 3-30 trimmers.

In the circuit shown a fixed crystal detector is used as V.H.F. mixer enabling more efficient operation to be achieved than with vacuum tube circuits.

A 6J5 may be used for frequencies up to 60 mc. but a miniature type 9002, 6C4, 9001 or 6AK5 would be the logical choice for frequencies above this.

Coupling is adjusted for sufficient signal injection, approximately 2in. being optimum, too tight coupling will increase noise level and decrease signal strength.

Care must be taken not to allow the oscillator to super-regenerate. Omitting the usual RF choke and substituting a 20,000 ohm  $\frac{1}{2}$  watt resistor would ordinarily suffice here, but HT voltage may have to be adjusted.

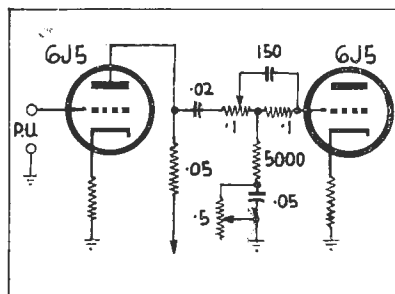

The circuit for a combination bass and treble tone control.

## Bass and Treble Control.

Here is a well tested and well tried dual tone control capable of giving a Low and High Frequency boost of up to 15 Db.

However, to compensate for this an extra stage of gain is required. Substituting a 6F8G or 6SN7 in place of one of the 6J5's will offset for the loss by the insertion of the tone control.

## Miniature Tube Shield.

A simple but efficient miniature tube shield may be made from a piece of  $\frac{3}{8}$  in. or  $\frac{1}{2}$  in. copper braid. The braid is enlarged and shaped over a suitable screw driver handle. The end is twisted and then secured with a spot of solder. A long solder lug earths the shield to chassis.

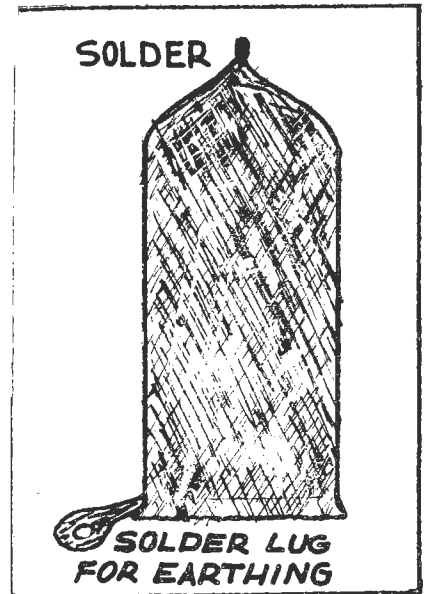

Method of making a miniature tube shield from copper braid.

## DID YOU MISS THESE ARTICLES?

FEBRUARY, 1948.

Build the Minimior Portable.  
Can you Read Circuit Diagrams?  
Low Cost Amplifier.  
The ABC of Frequency Modulation.

Speaker Network Design Data.

MARCH, 1948.

The Minimior AC Mantel.  
UHF Techniques.  
Convert the AR-301 to FM.  
A Two-Valve Tuner Unit.  
An Abac for Designing Resistors.

APRIL, 1948.

High Frequency Heating.  
Dual Purpose Amplifier.  
F.M. Antennas.  
A Versatile Signal Tracer.

Copies of the above issues are still available, and can be obtained by writing direct to the Subscription Department, Box 5047, G.P.O., Sydney. The price in each case is 1/-, post free.



# ANALYSIS OF RADIO INTERFERENCE PHENOMENA

## CHARACTER, CAUSE, TYPE OF RECEIVER AFFECTED, WHERE PREVALENT, SERVICE REMEDIES

32

TYPE OF INTERFERENCE	CHARACTER OF INTERFERENCE	CAUSE	TYPE RECEIVER AFFECTED	WHERE PREVALENT	SUGGESTED SERVICE REMEDIES
IMAGE RESPONSE	Heterodyne whistle or second signal when tuned to certain stations.	Strong Signal at a frequency twice I.F. above desired station.	Superheterodyne only. (1) With limited number of tuned circuits ahead of first detector. (2) With low impedance HF resonant antenna circuits.	Locality strong broadcast stations near high end of band. Vicinity 1610-1750 kc. and 1700-2000 kc.	(1) Wave trap tuned to interfering station. (2) Re-align I.F.
HARMONIC OF I.F.	Heterodyne whistle when tuning a station having same frequency as a harmonic of I.F.	Second harmonic of station. Combines with oscillator fundamental forming a spurious I.F.	Superheterodyne only. Selectivity does not affect.	Vicinity of station operating at twice I.F.	(1) Wave trap tuned to station. (2) Wave trap tuned to station 2nd harmonic in mixer grid circuit. (3) Re-align I.F.
DIRECT I.F. RESPONSE	Non-tunable code with intensity increasing toward low frequency end of band.	Commercial shore to ship code signal having frequency in I.F. range reaching input to I.F. system.	Superheterodyne only. (1) With limited selectivity ahead of I.F. input and relatively high I.F. gain. (2) With high impedance LF antenna system.	Coastal areas near location of commercial stations.	(1) I.F. wave trap. (2) Re-align I.F. (3) Orient loop for minimum interference.
HARMONICS OF OSCILLATOR	Reception of Short Wave code or Broadcast signals at points in standard Broadcast band.	Oscillator harmonics combining with SW signals and producing the required I.F. Especially prevalent on loop receivers due to secondary of loop.	Superheterodyne only. (1) With loop antenna. (2) Having oscillator rich in harmonics.	Rurally and where SW signals of proper frequency are intense.	(1) Use wave trap on interfering station. (2) Orientation of loop. (3) Re-align loop circuit. (4) Reduce oscillator coil excitation.
COMBINATION OF I.F.	Whistle or second station(s) heard on practically all carriers.	Differences in frequency of two strong stations equal to I.F. of receiver—the two stations mixing within the receiver to form a constant spurious I.F.	Superheterodyne only. Having limited selectivity ahead of first detector.	Metropolitan areas generally.	(1) Check by tracking of RF and antenna circuits. (2) Reduce size of effectiveness of antenna. (3) Instal wave trap and tune to frequency of one of interfering stations. (4) Shift I.F.
HETERODYNE OSCILLATOR RADIATION	Whistles on a particular desired station disappearing or changing frequency at random.	Radiation of receiver heterodyne oscillator, due to oscillator strength, unusual coupling, resonant antenna, or transmission via power line.	Superheterodyne only. (1) Without good shielding. (2) Without RF stage.	Metropolitan areas generally.	(1) Filter power line. (2) Reduce Osc. grid leak. (3) Shift I.F.
CROSS MODULATION WITHIN RECEIVER	Second station(s) appearing in background when tuned to desired station.	Strong interfering station modulating carrier of desired station within a non-linear circuit or element of the receiver, or pick-up and detection taking place in the audio system.	TRF and superheterodyne (1) With limited or no selectivity ahead of 1st tube. (2) With exposed grid circuits and wiring associated with early tuned circuits. (3) Without Var-mu input valves.	Metropolitan areas. Vicinity of very strong stations.	(1) Wave trap in antenna tuned to station causing trouble. (2) Filter power line. (3) Shield grid leads and wiring of first stages.
SAME CHANNEL BEAT	Flutter, waver or growl, heard in background when tuned to desired station.	Second station assigned to same channel, but differing very slightly in carrier frequency.	Receivers with high sensitivity and extended bass response.	In areas remote from a usable assortment of strong stations and wherever signals from two stations on same channel are comparable in strength.	(1) Use directive or loop antenna. (2) Reduce bass response. (3) Reduce sensitivity of set.
ADJACENT CHANNEL BEAT	Steady 10 kc. note or whistle.	Adjacent channel carrier beating with carrier to which receiver is tuned.	TRF and superheterodyne. Especially those with limited selectivity and wide range of audio response.	Localities where adjacent channel station is strong compared to desired station.	(1) Suppress adjacent station with sharply tuned wave trap. (2) Re-align receiver carefully. (3) Reduce high frequency response. (4) Use directive antenna.
MONKEY CHATTER	Unintelligible modulation superimposed on desired station, having character of inverted speech.	Side band of adjacent channel overlapping side band and combining with carrier of desired station. Also caused by harmonic from over-modulation of adjacent station.	TRF and superheterodyne. Having wide band selectivity and audio response.	Localities where adjacent channel station is strong. Also aggravated by extended high frequency response of transmitter.	(1) Accurately re-align receiver to make more selective. (2) Reduce high frequency audio response.

# For your note book

A page of radio servicing hints and notes of practical value to the radio serviceman and technician.

All of us have, at some time or another been puzzled by the operation of a certain circuit in a receiver awaiting repair. Consequently details of an obscure fault recently found in a superheterodyne receiver should prove of interest. At the time the symptoms exhibited were inability to receive any stations and as the tuning condenser was rotated only weak heterodynes were heard.

Adopting a standard servicing procedure, the power supply was first checked since none of the other stages could operate properly if there was any trouble here. Standard testing methods with the usual meters will readily show up most of these troubles in a few minutes.

The next logical step is to inspect the audio system. Whilst again meters can be used to determine the voltages and current drains on the various valves, a complication present itself. The valves may be receiving their proper voltages, but what about the audio signal circuits?

To check these we must first introduce the first intangible an a-f signal. This may be done in many ways but probably the simplest method is to place the finger on the control grid of the a-f valves. This will usually produce a satisfying "buzz" in the speaker indicating the audio stages are operating properly. Next to examine is the second detector.

## Diode Voltage.

This is the usual diode detector circuit, the operation of which may be compared to the high voltage rectifier checked in the power supply. Although not a full wave rectifier, it still presents a similar circuit. A transformer feeds a diode, a d-c voltage is developed for the AVC line, an a-c or a-f voltage feeds the audio system, and any r-f is bypassed in the filter circuit.

Although there is nothing much here for the meters to check the voltmeter was placed across the diode load. The reading was 68 volts! Where did that come from? Possibilities of a shorted duo-diode-triode or possibly plate voltage coming through

from the i-f transformer of the previous stage are considered, but rejected as the meter shows a negative voltage.

Normal action of the diode provides such a voltage for AVC use, but at much lower values. A very high signal input could cause this voltage, but once again this was ruled out as being unlikely.

As a check the set was tuned in—no stations could be received, but instead a few weak heterodynes were coming through. This sounded like oscillation in either the r-f or i-f stages of the receiver. And it was. A powerful oscillation in the i-f stage preceding the diode was being fed into the diode circuit producing the abnormal voltage across the diode load resistor.

## Potential Source of Oscillation.

As a potential oscillator the i-f stage contains all but one of the essential elements. The tuned grid and tuned plate circuits only require grid to plate capacitance in the tube for feedback to produce oscillation. This is normally prevented by the screen grid when it is properly bypassed, but if the screen condenser open-circuits the stage will oscillate causing the trouble mentioned.

Not all oscillation in the i-f stage will cause the relatively high voltage at the diode load. Quite often the stage will only oscillate weakly allowing the received station to come through with fair volume but with a heterodyne whistle at each side of the carrier.

In this case the actual part causing the condition may be an open bypass condenser in the screen, cathode, grid det

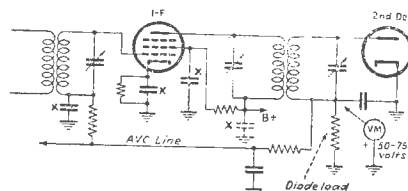

If the i-f stage oscillates, the diode will rectify the r-f current, and produce a high negative voltage across the diode load resistor.

turn or plate circuit. In some sets the open cathode condenser may not cause an oscillating condition, but rather a loss of volume due to the small amount of degeneration in the unbypassed cathode.

## Small Transmitter.

The relatively powerful oscillation that shows up on the diode load resistor is most often found in straight a-c receivers where the plate voltage is much higher. Here the oscillation may occur at a frequency determined by the grid and plate i-f tuned circuits, roughly the i-f frequency, or the frequency may be determined by the constants in that portion of the plate power supply, that now becomes part of the tube's plate circuit. In this instance the grid circuit will probably resonate through the grid return filter resistors and condensers in the AVC line. Variable with each receiver, this would probably take place at a rather low frequency.

Occasionally a set is found with an oscillating i-f stage that will not respond to the "substitution" treatment outlined. When this occurs, it may be found that a slight detuning of one of the trimmer condensers of the i-f stage will eliminate the oscillation and allow nearly normal operation.

## Decrease I-F Coupling.

This trouble has been most often encountered in receivers that employ a high gain i-f stage that is operating rather close to the point of oscillation. As a remedy some technicians decrease the coupling of one of the i-f transformers by moving the windings further apart. This may not be practical in some cases and an easier method would be to slightly increase the value of the cathode resistor.

In this case it is assumed that variable operating conditions in the field have caused the oscillation and that it is not due to a breakdown in the set. If the lowest voltage section of the voltage divider opens a somewhat similar action may take place due to the increased terminal voltages to the tube.

# U.H.F. Techniques

By  
HARRY N. EDWARDES, B.Sc., B.E.

The Klystron, described in this article is a centimetre wave generator employing the principle of velocity modulation. It is the only tube practicable for low power continuous operation above 3000 Mc.

The Klystron is a centimetre wave generator employing the principle of velocity modulation. Velocity modulation generators date from 1935, when A. Arseniewa-Heil and O. Heil described "a novel method of generating short, continuous electromagnetic waves of high intensity" in a German journal of Physics.

R. H. and S. F. Varian in the U.S.A., however, are credited with the invention of the Klystron in which they combined the principle of velocity modulation with resonant cavities to produce centimetre oscillations. The name Klystron was derived from a Greek word *klyzo* meaning the "breaking of waves on a beach".

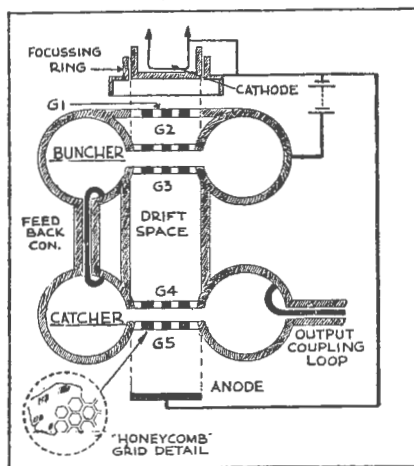

Fig. 1.—This diagram indicates the general construction of a Klystron.

The Sperry Gyroscope Co. manufactured tubes based on the Klystron principle.

A later development was the Reflex Klystron, in which a single resonant cavity was used in place of the two cavities of the original klystron. These reflex oscillators have been produced in large quantities in England, U.S.A., Canada and Australia and were used extensively as local oscillators for microwave radar systems.

Reflex klystrons have also been used in microwave test equipment as sources for signal generators, spectrum analysers and test oscillators for impedance and aerial pattern measurements.

The modern magnetron is capable of supplying high pulsed powers, but the klystron is the only tube practicable for low power continuous wave operation above 3,000 Mc/s for the above applications. Further uses for klystrons lie in the field of communication and radio relaying and present day developments are towards the production of higher power klystrons for this purpose. There will doubtless be other applications of microwave techniques requiring either high power klystrons or c.w. magnetrons.

## Description of the Klystron Tube.

The construction of the klystron as developed by the Varian Brothers is illustrated in Figure 1. This diagram represents a section through the axis of the tube.

At one end there is an indirectly heated cathode which acts as a source of electrons. Between this cathode and the anode at the other end of the tube there are five grids through which the electron stream passes. The first grid  $G_1$  is termed the accelerating grid and is maintained at a high D.C. potential relative to the cathode. The other four grids permit the electrons to pass through two toroidal or doughnut-shaped cavities which act as U.H.F. tuned circuits.

## PART 4. THE KLYSTRON

The cavity grids are all at the same D.C. potential, but serve as a link in the interchange of radio frequency energy between the resonators and the electron stream.

The anode or collector is at the same

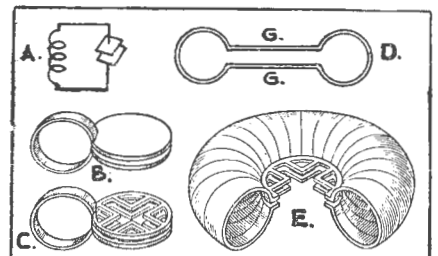

Fig. 2.—Development of a cavity resonator.

potential as the cathode and removes electrons after they have completed their tasks with the grids.

## Cavity Resonators.

In order to understand the operation of the klystron, some consideration of the properties of cavity resonators is necessary.

Although Lord Raleigh first described resonant cavities in 1897, they have been used in only recent years. As mentioned in previous articles, cavity resonators have been applied as tuned circuits in U.H.F. triode oscillators and magnetrons.

A mathematical analysis of different shapes of cavities was carried out by Dr.

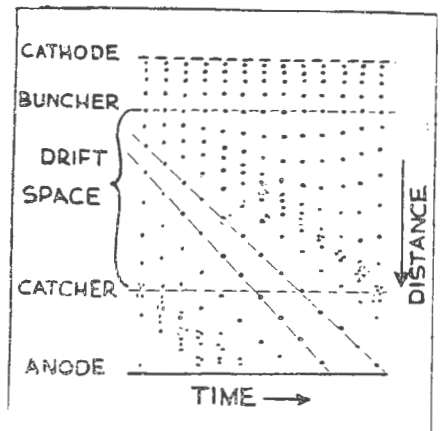

Fig. 3.—The "bunching" action of the electrons passing through the valve.

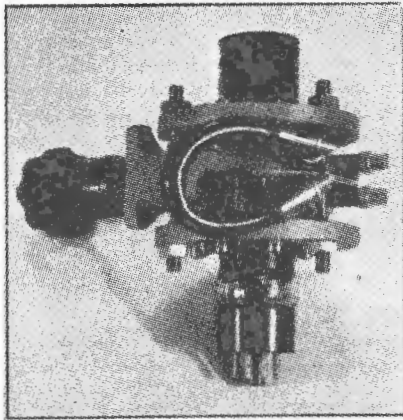

Fig. 4.—A Sperry type 410 R/2K30 Klystron. The fine tuning knob is on the left, whilst the cooling fins, co-axial output connectors and feedback loop are also visible.

Hensen in the U.S.A. and the Varian Bros. made use of his results in their klystron development. They called these practically closed metal vessel *rhumbatrons*, from the Greek *rhumba* meaning rhythmic oscillation, the termination *tron* denoting the place where such oscillations occur.

The toroidal cavity resonator can be considered as being developed from a coil and condenser circuit as indicated in Figure 2. The lumped circuit theory cannot be applied strictly in this case, however, since the dimensions are of the same order of magnitude as the wavelength. The concept thus serves purely as an analogy.

Instead of the conventional quantities of self inductance capacity and resistance which are used for lumped circuits, the concepts of "Q", frequency and shunt impedance are employed in the theory of rhumbatrons.

It is possible to obtain values of "as high as 50,000" with cavities, although those used in klystrons have Q's of about 1,000. Cavities are practicable only in the microwave band because the size increases with wavelength.

### Main Advantages.

As well as having high Q's cavity resonators incorporate other desirable features. There are no leads or thin wires to cause losses. No dielectric is required so that dielectric losses are eliminated. Radiation is impossible because of the totally enclosed self-shielding nature of cavity resonators.

Resonant cavities may be of any shape; the spherical form has the highest Q, while cylindrical cavities are most convenient for magnetrons. However, the re-entrant toroidal cavity was used in the klystron for the following reason.

If a cavity is resonating and electrons are passed through the cavity in the direction of the field where it is strongest, these electrons are accelerated and

extract energy from the cavity. Conversely electrons passing through against the field are decelerated and deliver energy to the cavity or excite it.

For efficient exchange of energy the electrons must pass through the cavity before the field changes in polarity. If a resonating spherical cavity were used, for example, theory has shown that the electrons could not get through before the field reversed, even if they travelled at the speed of light.

In order to provide a much shorter path for the electrons passing through a cavity a re-entrant shape of the type depicted in Figure 2d, Q, is necessary. This shape gives rise to a very strong field between the two surfaces G, G, as shown in Figure 2d. This field is in a direction at right angles to these surfaces, and it is in this direction that the electrons move in the klystron. For the electrons to pass through the cavity the G, G, must be perforated or made in the form of grids, as indicated in Figure 2e. The spacing between these grids must be such that the electrons will pass across the gap in less than half a cycle.

### Klystron Operation.

The cathode assembly or *electron gun* as it is usually termed, supplies a beam of electrons which is speeded up by the first *accelerating grid*  $G_1$ . This technique is employed in cathode ray tubes.

Assume now that the first rhumbatron is resonating so that a high frequency field exists between its grids. Electrons passing through the cavity at different times in the alternating cycle will be speeded up or slowed down to varying degrees from their mean speed. As a result, electrons leaving  $G_3$  at different times through the cycle will have different speeds.

These electrons which were speeded up

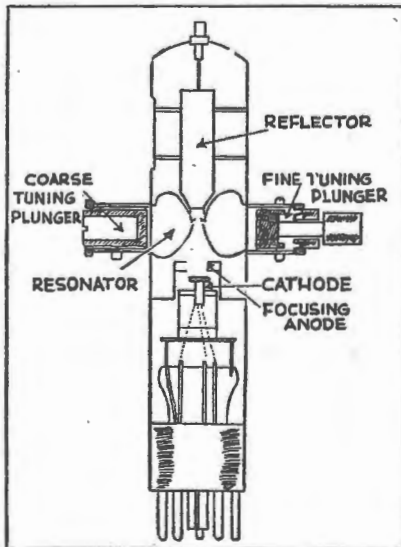

Fig. 5.—A sectional drawing of the CV35.

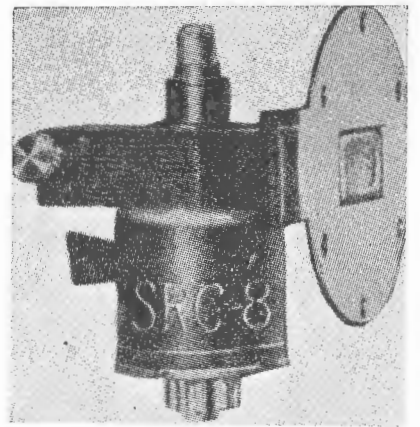

Fig. 6.—A Sperry type SRC 8 High Power Reflex Klystron.

move closer to those which were slowed down as they move along the *drift space* after  $G_3$ . As a result the electrons become arranged in groups or bunches and the first rhumbatron is called the *buncher*.

This bunching action of the electrons is illustrated in Figure 3. Each vertical row of dots in this diagram represents the positions occupied by electrons at different instants of time throughout the cycle. The differing speeds of electrons which passed through the buncher at different times are indicated by the different slopes of lines drawn through dots representing the same electrons.

The length of the drift space is such that the bunching effect is most marked at the grids  $G_4$  and  $G_5$  of the second rhumbatron. The density of electrons between  $G_4$  and  $G_5$  varies at the same frequency as the bunching. In other words, the electron stream is intensity modulated at the second rhumbatron as a result of velocity modulation at the buncher.

### The "Catcher."

This stream of electrons of varying density produces an oscillating field across the second cavity and causes it to resonate if it is tuned to approximately the frequency of the intensity modulation. Thus the second cavity is able to extract energy from the electrons and for this reason is termed the *catcher*.

If the energy extracted is greater than that necessary for the bunching operation, the extra radio frequency energy comes from the D.C. energy which accelerated the electrons initially. This is the case in the klystron because the energy required to organise the electrons into bunches is much less than that available from them by virtue of this organisation in bunches. The klystron therefore functions as an amplifier.

If some of the energy from the catcher is fed back to the buncher in the correct phase, self-sustained oscillations may be

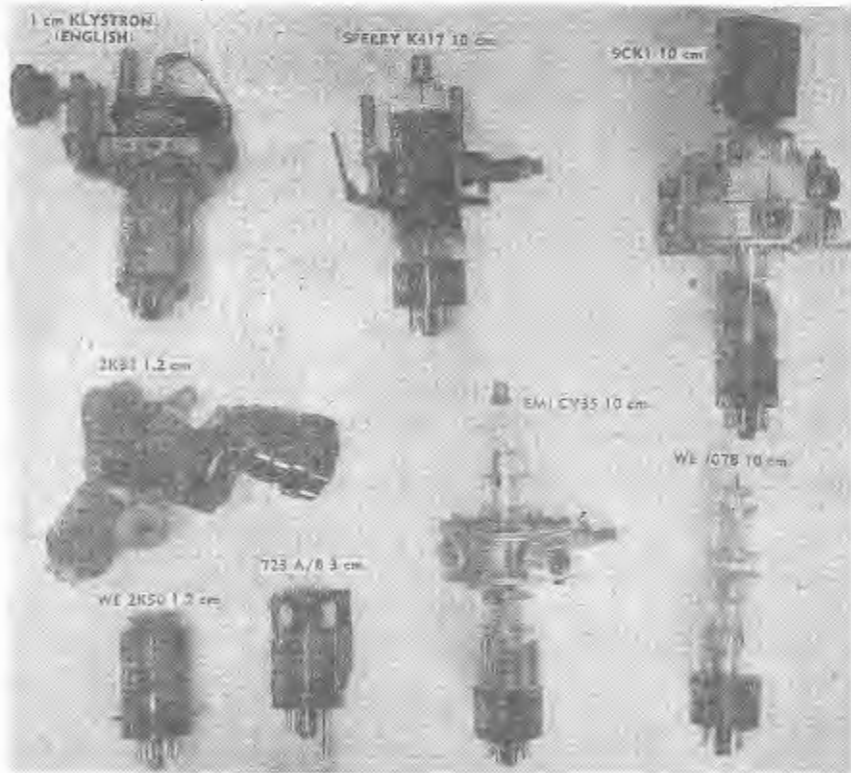

Fig. 7.—A representative group of Klystrons.

produced as in the case of a triode feedback amplified. Coupling loops in the two cavities connected by a co-axial line as indicated in Figure 1 serve as a feedback circuit. Control of the phasing is possible by varying the potential between the accelerating grid and cathode. This varies the mean speed of the electrons. R.F. output may be obtained from the catcher by means of a coupling loop and co-axial line.

After delivering their energy to the catcher the electrons move on to the anode or collector. Since they are not all brought to rest or to a very low velocity their remaining energy is converted into heat in the anode. Klystrons are fitted with radiating fins to dissipate this heat.

Calculations made by Webster showed that the ideal efficiency of a Klystron amplifier was 58 per cent., assuming perfect grids and other parts. Among the

factors which prevent this being realised in practice are de-bunching, secondary electrons and resonator losses. Also it is possible in practice to convert into electron energy in the beam only about 70 per cent. of the D.C. energy supplied from the accelerating voltage. The excitation or feedback in an oscillator also causes losses.

Losses in the resonators are minimised by using low resistivity material such as copper or even silver or gold-plated metal.

### Tuning of Klystrons

The Varian Brothers in their experimental klystron found it necessary to adjust the two cavities to the same frequency by mechanical deformation. In the tubes produced by Sperry adjustments were provided on the two cavities in order to obtain equal resonant frequencies as well as to permit tuning over a range of frequency. Portions of the cavities were made in the form of corrugated diaphragms. Two sets of screws were provided for adjustment of the individual cavities and coarse tuning, while a single vernier screw deforming both cavities equally supplied a fine tuning control. The resonant frequency of the cavities is varied by virtue of the change in capacity across the gaps of the rumbatrons.

Limits are set to the frequency range available by this method of tuning. Firstly, if the spacing is too great the condition that electrons must traverse the gap between grids in less than half a cycle is not fulfilled. Secondly, if the spacing is too small the klystron will not operate due to the decrease in shunt impedance or alternatively the tuning

(Continued on page 46.)

The Midget Three Gang Variable Condenser reviewed in "Around the Industry," RADIO SCIENCE May issue.



## ROBLAN COMPONENTS

Now available to YOU everywhere are ROBLAN midget two and three gang variable condensers, which are of higher quality and lower price than any other manufactured in Australia.

- ★ 9—370 mfd  $\pm$  2%.
- ★ High Q — admirably suited for broadcast and S.W. equipment.
- ★ Ball bearings ensure long service life.
- ★ Insulation of highest grade imported British bakelite.
- ★ Tracks with standard H type dials.
- ★ Lowest priced 3 gang on the market.

Manufactured by **ROBERTSON & LAWSLEY PTY. LTD.**  
**LEICHHARDT, N.S.W.**

Trade Enquiries to **ELECTRONIC INDUSTRIES**

# SERVICE DATA SHEET

A.W.A.  
RADIOLA MODELS



614-T

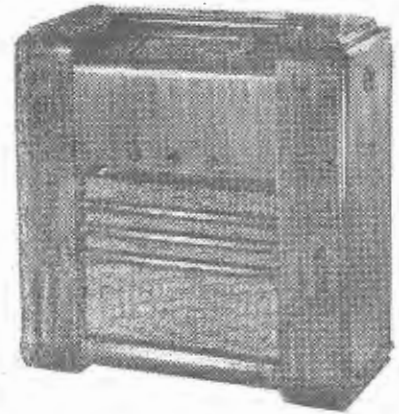

711-C

## ELECTRICAL SPECIFICATIONS

### FREQUENCY RANGES:

- (1) 1600-540 Kc/s.
- (2) 4-1.5 Mc.
- (3) 10-3.7 Mc.
- (4) 15-9.5 Mc.
- (5) 23-14.7 Mc.

### VALVES:

Converter 6J8G  
IF Amplifier 6SK7GT  
Det. AVC and 6SQ7GT AF Amplifier  
Power Output 6V6GT  
Rectifier 5Y3GT

### LOUDSPEAKER:

7 inch, 1500 ohm FC, V Coil  
Impedance, 3 ohms.  
12 inch, 1500 ohm FC, V Coil  
Impedance, 2.2 ohms

INTERMEDIATE FREQUENCY: 455 Kc.

### POWER SUPPLY:

200-260 volts, 50-60 cps.

POWER OUTPUT: 4.5 watts

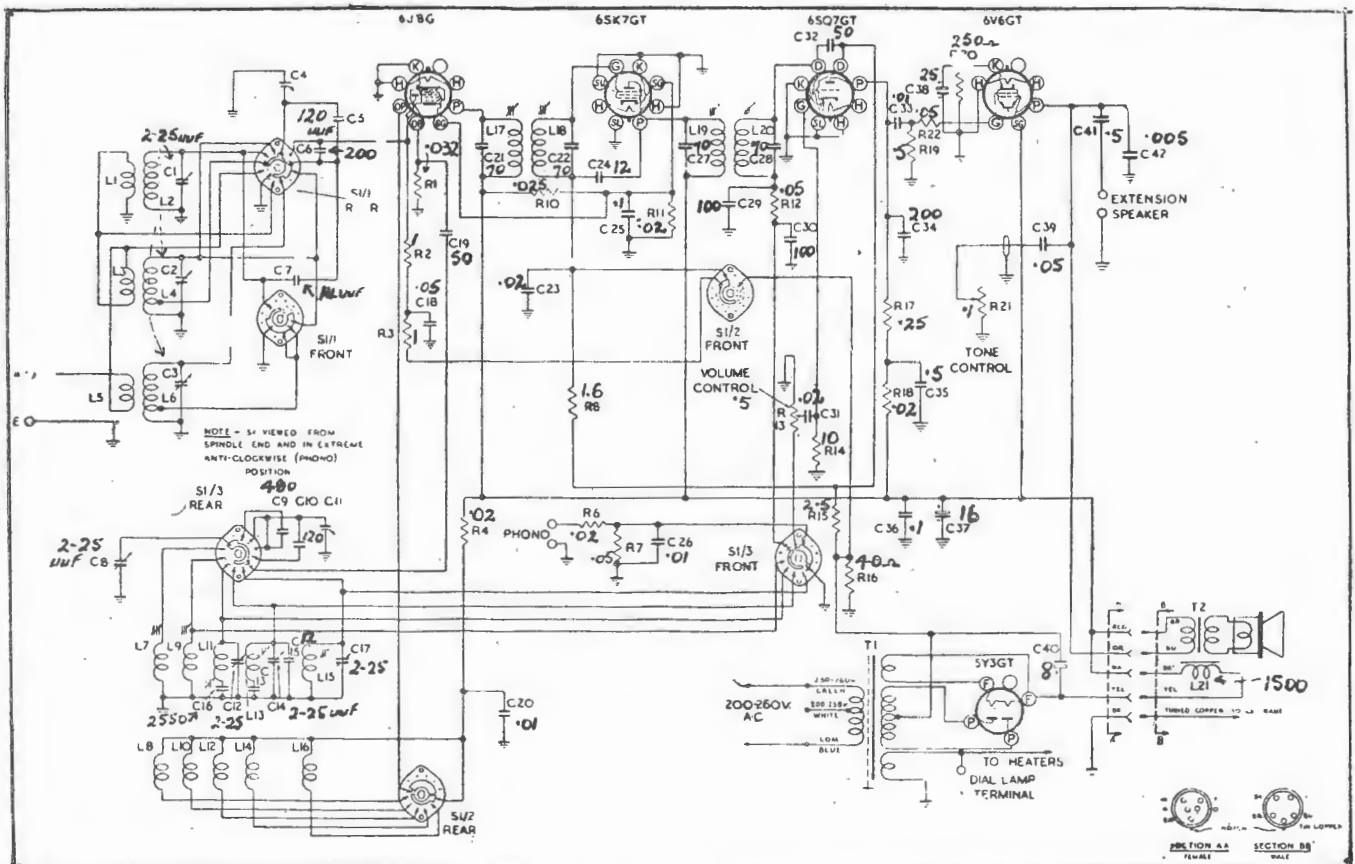

## ALIGNMENT PROCEDURE

When using a signal generator or modulated oscillator with the tuning of the receiver fixed, two frequencies can be tuned from the test instrument, one 0.92 Mc/s higher in frequency than the other. In all cases the desired frequency is the lower of the two.

For all alignment purposes connect the "low" side of the signal generator to the receiver chassis.

Perform alignment in the proper order as shown in the chart, starting from No. 1 and following all operations across, then No. 2 etc.

Keep the volume control in the maximum clockwise position and regulate the output of the test instrument so that a minimum signal is introduced to the receiver to give a standard indication on the output meter. This will avoid AVC action and overloading.

When the receiver has been satisfactorily aligned, seal the adjusting screws with a small quantity of cellulose cement.

**ALIGNMENT TABLE.**

Align-ment Order.	Test Inst. Connect to Receiver.	Frequency Setting.	Band Setting	Calibration Scale Setting.	Circuit to Adjust.	Adjustment Symbol.	Adjust to Obtain.
1	6J8G Cap.*	455 Kc/s	Broadcast	0°	2nd I.F. Transformer	Core L20	Max. Peak
2	6J8G Cap.*	455 Kc/s	Broadcast	0°	2nd I.F. Transformer	Core L19	Max. Peak
3	6J8G Cap.*	455 Kc/s	Broadcast	0°	1st I.F. Transformer	Core L18	Max. Peak
4	6J8G Cap.*	455 Kc/s	Broadcast	0°	1st I.F. Transformer	Core L17	Max. Peak
Recheck 1, 2, 3 and 4.							
5	Aerial	600 Kc/s	Broadcast	20°	Oscillator†	Core L15	Max. Peak
6	Aerial	1500 Kc/s	Broadcast	155°	Oscillator	C17	Calibration
7	Aerial	1500 Kc/s	Broadcast	155°	Aerial	C1	Max. Peak
Recheck 5, 6, 7.							
8	Aerial	1.6 Mc/s	4-1.5 Mc/s	16°	Oscillator†	Core L13	Max. Peak
9	Aerial	3.6 Mc/s	4-1.5 Mc/s	147°	Oscillator	C14	Calibration
10	Aerial	3.6 Mc/s	4-1.5 Mc/s	147°	Aerial	C2	Max. Peak
11	Aerial	4.0 Mc/s	10-3.7 Mc/s	18°	Oscillator†	Core L11	Max. Peak
12	Aerial	9.5 Mc/s	10-3.7 Mc/s	160°	Oscillator	C12	Calibration
13	Aerial	9.7 Mc/s	15-9.5 Mc/s	21°	Oscillator	Core L9	Calibration
14	Aerial	14.0 Mc/s	15-9.5 Mc/s	153°	Oscillator	C8	Calibration
15	Aerial	14.0 Mc/s	15-9.5 Mc/s	153°	Aerial	C3	Max. Peak
16	Aerial	15.0 Mc/s	23-14.7 Mc/s	19°	Oscillator	Core L7	Calibration
Recheck 8-16. A compromise in adjustments between 13, 14, 15 and 16 may be made for best results on both bands.							

\* With Grid Clip connected. A 0.001 uF capacitor should be connected in series with the "High" side of the test instrument.

† Rock the tuning control back and forth through the signal.

The column headed "Calibration Scale Setting" refers to the 180° scale on the ganged tuning capacitor drum drive. Check the setting of the drum before taking readings. The zero mark should be opposite the pointer with the tuning capacitor fully closed.

## SOCKET VOLTAGES

Valves	Control Grid to Chassis Volts	Cathode to Chassis Volts	Screen Grid to Chassis Volts	Plate to Chassis Volts	Plate Current mA.	Heater Volts
6J8G Converter	-2.6	0	85	260	1.3	6.3
Oscillator	—	—	—	150	5.0	—
6SK7GT IF Amplifier	-2.6	0	85	260	6.5	6.3
6SQ7GT Detector, AVC and AF Amplifier	0	0	—	100*	0.6	6.3
6V6GT Power Output	0	12.5	260	240	45	6.3
5Y8GT Rectifier	770/385 volts, 70 mA Total current.					

Measurements taken with the receiver connected to 240 volts AC supply. Range switch at "Broadcast" and no signal input. Volume control maximum clockwise. Voltmeter, 1000 ohms per volt; measurement taken on highest scale giving accurate readable deflection.

\*This reading may vary, depending on the resistance of the voltmeter used.

## TUNING DRIVE CORD REPLACEMENT

The accompanying diagram shows the route of the cord and the method of attachment. Whilst fitting the cord, keep it taut and adjust the length so that the tension spring measures approximately 2" long when fitted. The spring should be sheathed to prevent it rattling against the drum.

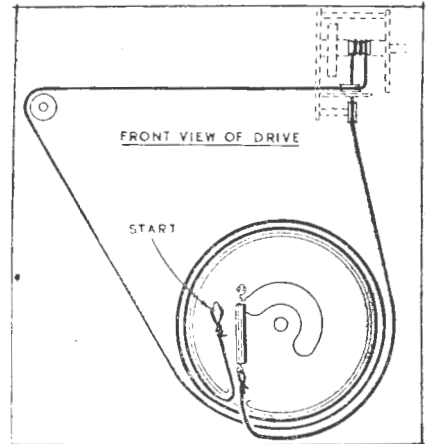

## SERVICE WINDOW

A "Service Window" is provided in the base of the table model cabinet. The window is covered by a perforated grille fastened by four knurled nuts. With the grille removed, it is possible to perform most service operations without removing the chassis from the cabinet.

## D.C. RESISTANCE OF WINDINGS

Winding	D.C. Resistance in ohms
<b>Aerial Coils—</b>	
Primary (L1)	13
Secondary (L2)	4
Primary (L3)	3.5
Secondary (L4)	2
Primary (L5)	2.5
Secondary (L6)	.5
<b>Oscillator Coils—</b>	
Primary (L7)	.5
Secondary (L8)	*
Primary (L9)	.5
Secondary (L10)	*
Primary (L11)	.5
Secondary (L12)	*
Primary (L13)	.5
Secondary (L14)	1.5
Primary (L15)	1.75
Secondary (L16)	7
<b>I.F. Transformer Windings</b>	
Power Transformer T2—	8
Primary	16
Secondary	520
<b>Loudspeaker Input Transformer—</b>	
Primary, XAI	500
Secondary, XAI	*
Primary, TX20	420
Secondary, TX20	*

Substitution of materials during manufacture may cause variations, and it should not be assumed that a component is faulty if a slightly different reading is obtained.

\*Less than 1 ohm.

# Around The Industry

## A.W.A. MAGNETIC PICKUP AVAILABLE

The A.W.A. studio pickup E52211, is an Australian made general purpose unit primarily intended for playing standard commercial recordings.

In designing this pick-up it was considered two features were essential, namely, the use of standard 5/8-inch phonograph needles, and the provision of a needle screw of sufficient diameter and size to be easily manipulated. The magnetic system is based upon the so-called "constant flux" balanced moving iron armature principle.

Although such an arrangement is usually characterised by somewhat higher distortion and lower needle compliance than is the case in moving coil types, these disadvantages were considered to be only partly inherent, and such is apparently the case since they have been largely overcome in the E52211.

The result of this design is shown by the nature of the frequency response. The characteristic is smooth throughout the range, the practical upper limit may be taken as being 7,000 cps and the overall distortion figure is extremely low. The average weight for tracking is 1.5 to 2 ozs., and this is adjustable by means of a tension spring screw located at the rear of the pick-up arm.

The complete unit is attractively finished in fine black crackle and satin finish chrome, and has a standard output impedance of 200 ohms.

Full technical details as well as response curves for this unit are now available from Amalgamated Wireless (A/sia.) Ltd., York Street, Sydney, and all enquiries should be forwarded direct to this address.



The A.W.A. E52211 Pickup.

## IMPROVED ROLA SPEAKER

A noticeable improvement in small speaker design has been effected by the Rola Co. with the introduction of their new 6-inch model—the Rola 6K.

This is fitted with a field magnet which is somewhat larger than that used on its

predecessor—the 6H and is made of the well-known anisotropic Alnico. This larger magnet produces a greatly increased magnetic flux across the air gap and achieves a power sensitivity of 3 db greater than the 6H. In actual tests the additional 3 db produced a signal which actually sounded almost twice as loud as that of the 6H.

The speaker can handle up to 6 watts input and has a fundamental diaphragm resonance of 110-120 cps. The greater sensitivity and improved transient response makes this speaker particularly suitable for the smaller battery and vibrator powered receivers where these improved characteristics show up to an advantage.

Supplies are now available from most radio retailers throughout all States, and the speaker can be purchased either with or without the requisite speaker transformer.



The Rola 6K Speaker.

## MIDGET POWER

### TRANSFORMER

The latest addition to the FN range of miniature components is a new power transformer, measuring only 2 3/8 in. x 2 3/8 in. x 2 3/8 in. It has been designed for either vertical or horizontal mounting, the latter use necessitating the removal of the two flanges required for vertical mounting.

The main specifications are:  
Primary: 240 v AC 50 cps.  
Sec. 1.: 150/150 v 30 ma.  
Sec. 2.: 6.3 v 2 amp.

Supplies are now available from the FN Radio and Electronic Co., Cremorne, N.S.W.



## NEW M.P.S. PRODUCTS

The recent introduction of a slow motion drive particularly suitable for use with radio or test equipment should interest all radio experimenters. The dial, which is an MSP product, features a direct drive on one section with a 55 to 1 ratio vernier on the other, and is fitted with a heavy celluloid pointer. Dial cards can be easily made allowing calibrations to be carried out according to personal requirements.

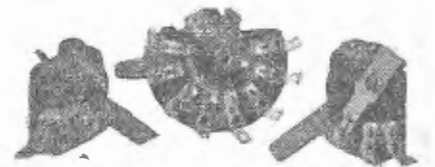

Another MSP product now available to the general trade is a series of small rotary switches. These are made in various combinations, the ones illustrated being: 1 pole 2 positions, 1 pole 3 positions, and 2 pole 3 positions, and are very useful for special switching operations where the larger type unit would be out of place.

Further particulars can be obtained on application to Manufacturers Special Products Pty. Ltd., 47 York Street, Sydney. samples made available by U.R.D. Pty. Ltd., Phillip Street, Sydney.



## B.R.S. HOME RECORDING UNIT

From the Birnbach Radio Co. comes details of their disc recording and playback unit—BRS model R12. This all Australian model is capable of excellent recording and reproduction and may be used in conjunction with any amplifier or high grade radio capable of an output of  $1\frac{1}{2}$  watts.

The fully enclosed traversing mechanism is operated by worm and quadrant gears making it impossible for this to become out of adjustment. In addition to recording for immediate playback on acetate base discs up to 12 inches, it is also a high quality pick-up unit.

The cutting arm is counter balanced by



an adjustable spring whilst the cutting head is a moving iron type performing the dual function of recording and playing back and this has a good response up to 6,000 cps.

Further enquiries should be forwarded direct to the manufacturers representatives: A. E. Harrold, Brisbane, Birnbach Co. Pty. Ltd., Sydney. Byer Industries Pty. Ltd., Melbourne. L. S. Wise & Co., Adelaide.

## MULLARD LSD-3 FLASH TUBE

Of special interest is the recent introduction of the Mullard Flash Tube type LSD-3. This is a three electrode gas discharge tube designed to provide light flashes of 100 to 200 micro-seconds duration making it admirably suitable for normal high speed press or studio photography.

The gas has a pure Zenon gas filling and will give satisfactory results with operating voltages as high as 2,700 volts. The minimum operating voltage is 1,000 volts. The oscillatory trigger voltage required is 1,500 volts and this can be obtained from a suitable spark coil. The maximum energy discharge is 100 joules.

Technical data is now available on request from Mullard-Australia Pty Ltd., Clarence St., Sydney.

## Q PLUS MIDGET COILS



As the result of the erection of a new factory by R. W. Steane and Co. Pty. Ltd., and the consequent increase in production, all 'Q Plus' midget coils and IF transformers are now readily available.

The Aerial and RF coils illustrated here, the oscillator coil (scheduled for early release) and the companion product—midget IF transformers are all intended for use in receivers where high sensitivity and compactness are required.

The overall size of these units is somewhat smaller than that of the new miniature series of valves, and are fitted with a single hole mounting on the base. They are all slug tuned and intended to cover the standard broadcast band with 455 kc. IF transformers.

Further enquiries should be directed to the manufacturers, Messrs. R. W. Steane & Co. Pty. Ltd., Auburn Victoria.

# **SORRY**

**OWING TO STOCKTAKING AND REMOVAL TO A NEW STORE, WE ARE UNABLE TO OFFER OUR CLIENTS ANY DISPOSAL GOODS THIS MONTH.**

## **Watch Out for Further Releases**

**Meanwhile, by arrangement with the proprietors, a large variety of Disposal Goods are available at**

**No. 5 ROYAL ARCADE, SYDNEY**

# **PARAGON RADIO**

# TRANS-TASMAN

# DIARY

By J. R. FOX

## N.Z. Mobile Recording Unit

The New Zealand Broadcasting Service's Mobile Recording Unit is probably the most unique of its kind in the Southern Hemisphere, if not in the world. Using an ex-Royal New Zealand Air Force checkers van, the mobile unit has been converted into an up-to-date recording unit. The reconstruction took place at the technical workshops of the N.Z. B.S. in Wellington, where the greater part of the equipment also has been manufactured.



The truck being used on an actuality outdoor broadcast. Lloyd Photo.

### Unusual Broadcasts.

Commencing its operation in September, 1946, the unit has travelled over a wide area which includes Wairarapa, Hamilton, Thamas Valley, Taranaki and most recently was at Dunedin during the Centennial Celebrations of that city.

The main purpose of the Mobile Recording Unit is to gather material for programmes where there are no radio stations located, and many interesting broadcasts have been recorded by the unit. Perhaps one of the most unusual was at Coromandel, when a recording was required and the relay lines would not reach to the point of the broadcast. However, this difficulty was overcome by using an ex-army ZC1 transceiver from the broadcast spot to the recording van. In another instance, when collecting material for a broadcast from the Waihi coal mines, over 2,000 feet of cable was fed down the mine shaft.

### Hydraulic Jacks.

For recording the van is placed on a level footing by four hydraulic jacks which are operated from the driver's seat. Spirit levels installed on the dashboard give the true level of the vehicle, which

takes an average of two to three minutes to be placed in position.

At the rear of the van is a large compartment which houses the relay and power cables. The relay lines are on six drums and can be run out to a distance of 3,000 feet. A trailer, with generating plant, can be attached if required.

In this new regular monthly feature our correspondent will report news of radio activities in New Zealand. It will contain items of interest to both the New Zealand and Australian reader and is a feature which should prove very popular.

New Zealand readers are invited to contribute any items concerning radio, broadcasting, DX-ing and amateur radio activities for inclusion in this section. All letters should be forwarded direct to: Mr. J. F. FOX, 41 Bird Street, St. Kilda, Dunedin, S.2. N.Z.

### Recording Machines.

Each cable comes into a two stage pre-amplifier, thence to a mixing panel which feeds the recording amplifiers and monitor. The recording amplifier is of the push pull type operating under class A conditions and giving 20 watts output.

The two recording machines which enable continuous recordings to be made run at 33.7 or 78.95 revolutions a minute. They can be adjusted to cut the acetate discs at 104 grooves to the inch, taking up to 15 minutes, 112 grooves—16 min-

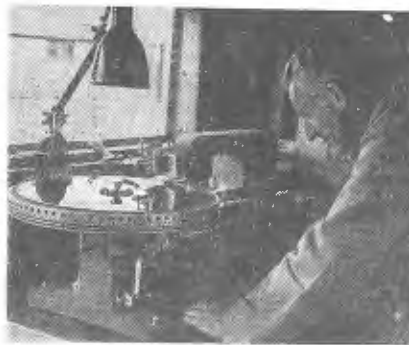

A close-up of one of the recording units. Note the holes around the turntable edge which form the built-in stroboscope used for checking the speed of the machine.

Lloyd Photo.

utes, 120 grooves—17 minutes and 128 grooves—19 minutes. Each cutting machine is provided with a built-in stroboscope, which is formed by two complete circles of holes cut around the edge of the turntable. When viewed under a 50 cycle light the holes appear to be stationary, thus allowing the speed of the machines to be accurately checked and maintained.

The fine precision work involved in the making of these recording machines is indeed a credit to the technical staff of the N.Z.B.S., and proves that in New Zealand we have the men and facilities for turning out first class radio equipment.

### 2LT SPECIAL N.Z. BROADCAST

Advice has been received from the management of Station 2LT, Lithgow, New South Wales, that they will broadcast a special programme dedicated to New Zealand DXers. Subject to the P.M.G.'s approval, the transmission will be heard on Sunday morning, July 4th, from 12.30 to 1.0 a.m. New Zealand time (10.30 to 11 p.m. AEST, July 3rd).

DXers are requested to listen for this special broadcast and send in a report to the station, whose address is: Lithgow Broadcasters Pty. Ltd., P.O. Box 21, Lithgow, New South Wales.

Station 2LT transmits on 1080 kilocycles with a power of 100 watts.

### Radio Directory.

Of great interest to all DX'ers is the recently received sample copy of the first edition of the "World-Radio Handbook for Listeners." This is published and edited by Mr. O. Lund Johansen, of Copenhagen, Denmark.

Mr. Johansen is to be congratulated on compiling the handbook, which contains information that no DX listener should be without. Station addresses, call signs, frequencies, powers, slogans, announcements, programme highlights, interval signals, names of leading personalities of each station and a broadcast and short-wave log are a few of the highlights of this outstanding booklet.

Readers interested in obtaining a copy of this publication should write to the Australasian agent, Mr. Arthur T. Cushen, 212 Earn St., Invercargill, New Zealand.

# ON THE BROADCAST BAND

## HAWAIIANS PROVIDE EXCELLENT SIGNALS

**From many parts of the Commonwealth and New Zealand reports have been received at our listening post regarding the excellent signals now being heard from stations located in the Hawaiian Islands.**

Around 2 a.m. (EST) appears the best time to listen for these stations when they may be heard presenting their early-morning programmes. It should be remembered when reporting reception of these transmitters that, although Hawaii is not such a great distance from our country, the appearance of the international date line between Australia and Hawaii results in a time difference of some 20 hours; thus, 2 a.m. in Eastern Australia corresponds to 6 a.m. (previous day) in Hawaii.

Many listeners may be surprised at hearing the Japanese language used from some Hawaiian stations, but the number of Japanese employed in these islands is apparently great enough to warrant the inclusion of radio programmes in their tongue. Generally, however, programmes from Hawaii are of the American type, with swing and hillbilly music being featured, and, strangely enough, very little island music has been heard.

KMVI 550kc Wailuku is heard fairly well around 2 a.m., this being one of the several stations in this group reported by Mr. Moore, of Brisbane.

KGMB 590kc, Honolulu, an old-timer, uses Japanese around 2 a.m., and must not be mistaken for the Tokyo Station JOAK, operating also on the same fre-

quency, and which has usually closed down by this time. KGMB is heard also at some locations around 7 p.m., with its late-night programme, this time in the English language.

KPOA, 630kc, Honolulu, one of the best signals in this group, is heard with programme in English.

By  
**ROY HALLETT**

QULA, 690kc, Honolulu, probably the strongest signal from Hawaii around 2 a.m. This station suffers interference here from 6WF (also on 690kc), until the latter station concludes its night transmission at 2 o'clock. This station verifies correct reception reports with a very attractive QSL card.

KGU, 760kc, Honolulu, heard in English, suffers interference from All India Radio's VUT Trichinopoly, on 758kc.

KHON, 1380kc, Honolulu, another of the Japanese language group, at 2 a.m.

New Zealanders hear KIPA Hilo, 1110kc, opening at 2 a.m. EST, but as 2UW Sydney is on the same channel with a 24-hour service, it is not likely KIPA will be heard well in this country. Mr. Art Cushen has just received his verification from this one.

## NEWS OF ASIATIC STATIONS

Reception of signals from the Philippine Islands should prove fairly successful during the coming winter months. Best time for listening is around 1 a.m., when these stations are heard with late-night transmission. American-type programmes may be heard from this group also, as well as presentations in Togalog (the language used by a great proportion of the Islands' population) and in Spanish.

KZFM, 710kc, Manila, has been heard by several DX-ers in this country.

KZRH, 750kc, Manila, an old-timer, being popular amongst Australian DX-ers for many years, provides one of the best signals from the P.I. at our listening post.

KZPI, 800kc, Manila, presents programmes almost entirely in English.

KZMB, 950kc, Manila, reported from several locations.

KZOK, 1000kc, Manila, operates mainly in Togalog, working in association with KZPI.

KZBU, 1250kc, Cebu City. Mr. Cushen and others hear this one till 2 a.m.

Operating under the call sign "Radio Malaya," stations operating at Singapore, 1333kc and 570kc, and Penang, 1270kc, have been heard by Mr. Art Cushen and others around 1 a.m. Latest airmail information from Singapore states that other stations operate from Malacca, Kuala Lumpur, and Seremban, also under the same call.

Two new Indians reported by Mr. Rex Gillett, Adelaide, likely to be heard here include: Patna, 1131kc with 5kw, and Cuttack, 1kw 1355kc.

VUY Dacca, 1167kc, is one of the strongest signals heard at present from India. Try around 1 a.m. for this and other Indians, with programmes in Indian native languages and occasional features in English.

A fairly strong signal is now being heard at present late at night on 870kc from WVTR, the American Armed Forces station in Tokyo, Japan. Shortly after the Allies entered Tokyo, WVTR's call-sign was heard on 590kc.

## NEW N.Z. STATION

The National Broadcasting Service has just announced plans for the erection of yet another unit in their chain, this time at Timaru, on the East Coast of New Zealand's South Island. Studios will be installed temporarily in the top storey of the Timaru Gas Co. building, whilst the transmitter, Australian made, is to be installed at Washdyke, right on the coast, some two miles from the studios. The aerial will be supported by a 200-ft. steel lattice-type tower.

The two-kilowatt transmitter will be operated by remote control from the studio, with regular checks at intervals by the station engineers. This type of operation is not permitted by the P.M.G. in this country, and is only used in this and similar cases in N.Z. in an attempt to limit station expenses. The station call-sign will be 3XC and the frequency 1160 kilocycles. It is hoped to have 3XC on the air by the end of this year.

## READERS' REPORTS

Several interesting verifications have been received by readers during recent weeks. Mr. Ray Rooke, of Manly, Sydney, has added the card from KSL Salt Lake City, 1160kc, to his collection, and is quite pleased with the card which carries a photo of station equipment.

★

Mr. Moore sent us along the letter he received verifying his reception of KSDJ, 1170kc, San Diego, Calif., U.S.A., for our inspection. KSDJ uses RCA audio equipment, with an RCA BTA5F transmitter. During daylight hours a power of 5kw is used, but in the evening the power is reduced—in this case to 1kw—to avoid as much as possible interference to other U.S.A. stations operating on the same channel. Aerial system includes three self-supporting towers in line 70 degrees (T).

★

Mr. A. J. McDonald, Cronulla, was pleased with our list of New Zealanders, particularly as it is so difficult to hear individual call signs during the morning session. Many of these stations relay the same programme, and consequently, when station identification is eventually given, little detail is provided. This reader reports also an Oriental signal on 590kc, which is almost certainly JOAK Tokyo.

★

Mr. Stuart Kerr writes us from Maryborough, Vic., reporting reception of what appears to be a new Philippines station on 920kc. This is possibly an outlet now being used by "The Voice of America," from Manila.

# SHORT WAVE LISTENER



Conducted by Ted Whiting

## IMPROVED CONDITIONS ON ALL BANDS

With the advent of winter reception conditions are rapidly improving and good listening is available on all bands used in Short Wave Broadcasting. It will be found that during this coming month many stations will be heard in the daylight hours which have been non-existent during the summer months.

We do urge our readers to keep a strict watch on all bands at this period of the year, a watch which will be well rewarded by good catches.

Excellent conditions have prevailed on the 6 M/c band, the stations of note now being heard on those frequencies being the South Africans in the early morning. The band will be found to be open from 4 p.m. and remains in that state until well after daylight. No doubt

many changes have yet to be made in schedules and more stations will be operating on this band by the time this appears in print.

The 8 M/c frequencies are again productive of some good signals mostly from the Central Americas, but conditions are not yet at their peak on these frequencies, possibly the best time will be July. We hope in our next issue to give prominence to this band and will compile a list of stations to be heard at around 8 M/c.

### Above 20 M/c.

Many readers have receivers which will receive signals on the 13 metre band, and it will be found that, at night especially, good signals are to be heard. The B.B.C. have made good use of this

band and the transmitters in use at present are all heard here in the evening hours. Hours of operation are as follows: GSH, 21470kc, 8 p.m.-3.15 a.m.; GSJ, 21530kc, 4 p.m.-6 p.m., 8 p.m.-10.15 p.m., 1.15 a.m.-4.15 a.m.; GST, 21550kc, 4 p.m.-8 p.m., 12.15 a.m.-3.15 a.m., 4 a.m.-7 a.m.; GRZ, 21640kc, 11.30 p.m.-1.30 a.m.; GVR, 21675kc, 3.30 a.m.-7 a.m.; GVS, 21710kc, 6 p.m.-11.15 p.m., 2 a.m.-7 a.m.

Other stations of interest are those on the 11 metre band, and heard here regularly at good level. The details are: GSK, 26100kc, 8 p.m.-11.15 p.m. and GSS, 26550kc, 9 p.m.-12.15 a.m.

We will be interested in reports on your reception on these bands, as there is a possibility that more stations will make use of these frequencies in the coming months.

## NEWS OF THE AMATEUR BANDS

As these notes are written there is much activity on the new band, 140-144 M/c. band—new equipment will require adjustment and experience on the band will have to be gained. This should result in good contacts being made and who knows over what distance?

The Six metre band has been for the most part rather deserted, no doubt due to the above activity, but when signals are likely to break through it is customary to hear many on the band. While primary a local band there seems no doubt that long distances will be covered with more or less regularity, and at present it would be wise to populate the band in anticipation of such events.

Ten is rather patchy these days, few overseas stations being heard at their usual level, but locals have been working the usual W, ZS and G signals at times.

Conditions on Twenty have improved, the usual continuous hetrodyne being evident at the week-end. However in the less busy periods some fine signals are heard, W signals are good in the afternoons and night periods.

More stations are heard on "80", interstate and ZL stations coming in well, although many are debarred from using this band by the fear of BCL.

Loggings for the past month include:—14 M/c Band.—England: G2DPZ, PU, ABB, PO, PW, XV, DPZ, G3CSJ, PD, PO, GW, AQX. G4AD, ADK, MH, MJ, HO. G5GK, XN, RW, UX. G6XR, GW, BC. G8CN, IG, NY, AW, MX. Scotland: GM8MF, KQ. Canada: VE3HI, ZL, LL, AL, VE4GE, VE7JK, EF, BO, VO, DJ, ZL, ZAA, ADJ, VE8MH. Trinidad: VP4GR. Holland: PAOMZ, UN, RU, Dw. Newfoundland: VO2AT, PT, AB. Luxembourg, LX1DU. 7 M/c Band.—Mexico: XE1IA. Fiji: VR2BA.

28 M/c Band.—New Zealand: ZL2FY, ZL1ON, ZL2DW, ZL3HZ. America: W6EZP, PKI, VCN, QR, SPV, ETY. Fiji: VR2AP. Africa: ZS5DU, BZ, ZS6OY, ZE2JA.

21 M/c Band. — W6BTY, VK2AFE, 2ADC.

50 M/c Band. — VK2FO, 2HO, 2JU, 2NP, 2WJ, 2EM, 2XG, 2BG, 2MQ.

## "RADIO AUSTRALIA" NOTES

Interesting news has been received from Radio Australia recently, their DX session filling a long felt need. It is reported in their session that the stations of the Broadcasting Corporation of Japan will now verify. Reports should be addressed to Mr. R. H. Nimo, Chief Liaison Section, Broadcasting Corporation of Japan, Tokio. Recent schedules are to hand. JKC, 7257kc, 5.55 a.m.-Midnight; JFK, 9655kc, 5.55 a.m.-5.45 p.m.; JFK2, 4910kc, 5.45 p.m.-Midnight; JO9K, 9550 kc, 10 a.m.-Noon, 2 p.m.-3.20 p.m.; JKA, 7285kc, 6.55 a.m.-9 a.m., 10.20 a.m.-11 a.m., 12.20 p.m.-1 p.m., 5.55 p.m.-11.30 p.m.; JKG, 9690kc, 6.55 a.m.-9 a.m., 10.20 a.m.-11 a.m., 12.20 p.m.-1 p.m.; JKG2, 4930 kc, 5.55 p.m.-11.30 p.m.; JWV, 15225kc, 8.30 a.m.-5.50 p.m.; JWV2, 9505kc, 5.45 p.m.-Midnight; JWV3, 15235kc, 8.50 a.m.-5.30 p.m.; JWV4, 9560kc, 5.45 p.m.-Midnight.

Further reports from this source indicate that Warsaw is heard from 4 p.m. until 6 p.m. on 9530kc, news in Polish is heard on the opening of the station at 3 p.m. The Polish National Radio is heard on 7010kc in a transmission to Iraq, Persia and Turkey between 1.30 a.m. and 2 a.m.

# LISTEN FOR THESE STATIONS

West Coast American stations in the A.F.R.S. network are heard well in this country, and no doubt the times of operation will be of interest. KCBA 15150kc, KCBF 11810kc, KWIX 9570kc, 1.15 p.m.-6.45 p.m.; KCBA 15330kc, KCBF 9700kc, KWIX 11860kc, 7 p.m.-12.30 a.m.; KGEX 17780kc, KNBX 15250kc, 3.30 p.m.-6.45 p.m.; KWID 11900kc, 3.30 p.m.-9.30 p.m.; KGEI 15120kc, 3.30 p.m.-8.30 p.m.; KGEI 9530kc, 8.45 p.m.-12.30 a.m.

☆ ☆ ☆

A new station operated by Radio Malaya, but carrying an alternative programme, is heard on 6120kc between 9.30 p.m. and 1 a.m. Opening signature tune of this transmitter is "Wings Over the Navy" and the announcements are in Malayan and other Eastern languages.

☆ ☆ ☆

Schedules of the Italian Short Wave stations are as follows: European Service, 6085kc and 9630kc, 1.45 a.m.-6.45 a.m.; Latin American Service, 15120kc and 9630kc, 8.30 a.m.-9.50 a.m.; North American Service, 15120kc and 9630kc, 9.55 a.m.-11.10 a.m.

☆ ☆ ☆

News in English is heard from Athens on 7295kc at 2.30 a.m. Despite many reports to the contrary, this station will verify and all letters should be addressed to National Broadcasting Company of Greece, National Broadcasting Institute, Athens, Greece.

☆ ☆ ☆

Radio Belgrano, Buenos Aires, has been reported heard at 8 p.m. for a brief period on 9545kc, but unfortunately is badly jammed by a Russian station on the same frequency. We would advise readers to tune for Radio Belgrano at 11 p.m. as reception is more likely at this time.

☆ ☆ ☆

Notes from our diary include one on a change of frequency to 6105kc by Radio Tabriz, which is in operation from 12.30 a.m.-3.30 a.m. A transmission in English is heard at 3.20 a.m. Often heard at good level.

☆ ☆ ☆

Radio Bucharest is looking for reports on their transmission. The station operates on 9250kc, and should be heard at 4 a.m. at the best level. We heard this station several times last year at 4.30 p.m., but cannot say whether the station is on the air at that time now.

☆ ☆ ☆

The British Forces station at Benghazi should be in operation by the time this issue reaches the streets. The frequency, you will recall, is 11850kc and will operate from 4 p.m.-6 p.m., 10 p.m.-Midnight and 2 a.m.-4 a.m. The announcement

states, "This is your Forces Broadcasting Station, Cyreneia."

☆ ☆ ☆

Radio Teheran, Iran, operates several frequencies at the present time. EQA 895kc, EQE 4790kc and EQD 6155kc are on the air from 9.30 a.m.-11.50 a.m. and 8 p.m.-1.30 a.m.. Reports from W.A. state that this station is heard at 6.15 p.m. with a fine signal. EQA 895kc, EQC 9680 kc and EQB 15100kc are operating from 4.30 p.m.-6.30 p.m.

☆ ☆ ☆

Test transmission have been heard Samoa. The station using the call

ZM2AP was heard on 7947kc between 4 a.m. and 4.30 a.m. Reports on ZF2AP should be addressed to Box 23, Post Office, Western Samoa.

☆ ☆ ☆

Guatemala City, TGWA, is again heard on 9760kc at 2 p.m., carrying the customary Spanish type programmes and closing on Sunday at 4 p.m. and often as late as 5 p.m. XERQ, 9615kc, is also heard at closing at 4 p.m. on Sunday with their customary service, and other stations to be heard at good level at the same time are XEWW, 9500kc; XEBT, 9625kc; XEHH, 11880kc.

## NEWS FROM AMERICAN CORRESPONDENT

**We have to hand some interesting notes compiled by Ken Boord, and kindly passed on to us by Miss Sanderson. Mr. Boord is the Short Wave Editor of "Radio News" and resides at Morgantown, U.S.A. His notes are dated 13/4/48 and the following comments should interest readers.**

News in Spanish for listeners in Spain is broadcast by local transmitters in Spain on the broadcast band and in addition on the following frequencies: 11.30 p.m., 37.7m, 42.07m, 42.83m; 6.45 a.m., 32.02m, 37.7m, 42.07m, 42.83m, 49.45m; 9 a.m., 42.7m. For listeners in South America a service is radiated daily at 9.50 a.m.-Noon on 32.02m.

Unfortunately no details of call signs are given, and any communication with regard to reception of these stations should be addressed to K. M. Dobeson, 12 Pelham Road, Southsea, Hants, England.

CQM4, Bisseau, Portuguese Guinea now verifies with an attractive card. Power is 1Kw, Telefunken transmitter, directional aerials operating on 7948kc, schedule 7.30 a.m.-9 a.m.

The new transmitter at Copenhagen should be in regular service at any time. A station has been heard in U.S.A., which may have been this new one testing, on 21560kc at 1.40 a.m.-2 a.m., American recordings and announcements in a Scandinavian language were heard. This one should be a good catch, and we feel sure the station staff would be delighted to hear of reception of their transmissions in Australia.

ZOY, Accra, Gold Coast, is heard regularly on 7290kc till close at 4 a.m., this station also verifies.

HH2S, Port-au-Prince, Haiti has English programmes on Thursday as 10.30 a.m.-11.30 a.m., will not be heard in Australia on its frequency, 5940kc, but New Zealand readers should look for this one.

Listeners in U.S.A. are hearing Radio

Eiraan, Ireland on 17840kc at 4.30 a.m.-4.50 a.m. with news etc. New high power transmitters are being constructed and will result in this station being heard in this country also.

Beirut is now operating on 8030kc and has an English session at 1 a.m.-2 a.m. daily. Possibly schedules of this station will be rather spasmodic in view of the circumstances in this area.

Oslo Radio, Norway has advised that the new 100Kw transmitter will be used in the near future now that the new aerial is completed. The frequency will possibly be 11850kc in the transmission now carried on 9610kc at 11 a.m.-Noon.

Another new station, this one located at Istanbul, Turkey, will operate with 100 KW in the spring with services directed to America, Far East, Australia, Africa and Western Europe. The projected wavelengths to be used will be chosen from the following, 41.19m, 32.89m, 19.78m, 16.87m, and 13.85m.

The new schedule of the Canadian stations as given by Mr. Boord gives a little information. CFRX, Toronto, was to leave the air, but due to popular demand is still in operation. This one may be off the air for a few days in early July when new beamed antennas will be installed directed on Northern Canada.

The International Service Summer Schedule; Europe daily, 11 p.m.-8.5 a.m. on CKNC, 2.5 a.m.-8.5 a.m. on CKCS 15320kc. Caribbean Area in English, on 12.30 a.m.-2 a.m.. To Australia and New Zealand in English, 6.45 p.m.-8.35 p.m. Sunday on CHOL 11720kc and CHLS 9610kc.

## READERS' REPORTS

Mr. Gillett, Prospect, S.A., the winner of the DX Contest of the Australian DX Radio Club 1947-8 writes of his successes. Incidentally, Rex compiled a total of 750 points in the contest, verifications being received from 52 countries numbering 123. This was a very fine performance indeed and we in turn offer our congratulations.

From South Africa, Mr. Gillett relays news of the South African Air Force station, ZRB, heard here at times on 9100kc. Weak signals were heard from ZRB at 11.45 p.m., but at the end of transmission at 4.55 a.m. the level was very good indeed. The programme consisted of recorded music and English and Afrikaans announcements were heard.

The complete schedule of the South African Broadcasting Corporation, Johannesburg is to hand. Two programmes are emitted, the "A" programme in English, and the "B" programme in Afrikaans.

Johannesburg No. 3 5Kw B:

3450kc not in operation.

4895kc, 1.50-7.5 a.m.

6007kc, 2.45-4.30 p.m. daily; 3.55-4.10 p.m.

Sunday.

9523kc, 6.15-10.10 p.m.; midnight-1.40 a.m.

daily; 6.15 p.m.-1.40 a.m. Sunday.

11710kc, not in operation.

Johannesburg No. 4 1Kw A:

4800kc, 2.45-4.30 p.m.; 2.20-7.5 a.m.

daily; 3.55-4.10 p.m. Sunday.

9870kc, 6.15-10.10 p.m.; midnight-2.10

a.m. daily; 6.15p.m.-1.40 a.m. Sunday.

Johannesburg No. 5 2Kw A:

4373kc, used on all sessions.

The latest schedule from TAP, Ankara, Turkey, 9465kc. News in Urdu, Persian, Arabic, English, French, Greek, Roumanian, Serbo-Croat, Bulgarian, German and Magyar at intervals between 2 a.m. and 6 a.m., these being listed as Foreign Language broadcasts. Other transmissions are on Monday 7.30-7.45 a.m., Post Bag, in English; Tuesday and Friday, 7.30-7.45 a.m., Special Broadcast for England; and fortnightly on Wednesday from 7.30-7.45 a.m., a special broadcast for U.S.A. The circular states that "your letters and the questions you raise will be answered both over the air and by mail. All correct and detailed reception reports are verified on one of our new illustrated QSL Cards".

☆ ☆ ☆

A further New Zealand reader sends along an interesting report giving details of two stations located in the Philippine Is., KZPI on 9500kc operates from 8-2.35 a.m., programmes being in English and Talalog mainly. KZOK, 9690kc, "The Friendly Station" also operates on the same schedule. Both transmitters are operated by "The Philippine Broadcasting Corporation, 5th Floor, Rocas Building, Manila," and will verify on correct reports.

☆ ☆ ☆

Mr. A. T. Cushen, Invercargill, N.Z. sends along a fine log also. In it he mentions many stations in which readers will be interested.

ZOY, Accra, Gold Coast, 4900kc signs off at 4 a.m., after news and comment.

HH2S 5948kc, Port-au-Prince, Haiti; this one heard from 9.30 p.m. daily.

Forces Broadcasting Service, Jerusalem; heard at good level till 7.5 a.m. daily.

The American Forces Network have now withdrawn the short wave outlet, this being replaced by the German station, "Radio Munchen," located at Munich. The transmission is heard on 6080kc from 3 p.m. daily, while the "Voice of America" takes the transmitter over from 2 a.m.-8 a.m. daily. Radio Munchen verifies, address report to Office of Military Government for Bavaria, Rundfunkplatz 1, Munich.

Another station reported is CS2WD, Lisbon, Portugal. This outlet is heard at fair level at 5.30 a.m.

# Club Notes and News

## HURSTVILLE DISTRICT AMATEUR RADIO CLUB

C.W.A. Rooms, 378 Forest Road,

Hurstville, N.S.W.

President: F. Tregurtha.

Secretary: C. Coyle.

The last General Meeting saw the return of the President (VK2FT) from a two months' sojourn in Tasmania and New Zealand. He was very enthusiastic about the Hobart Branch of the W.I.A. in regard to the loyalty of its members (its membership being almost 100 per cent. of Amateurs in Tasmania) and its organising ability. Members travelled a hundred miles or so to be present at the Anniversary Dinner and to take part in the Field Day held the next day, and the latter, in particular was extremely successful as a D/F hunt.

The programme for the Club's activities during the ensuing month has now been drawn up, and all members and any intending members are requested to make a note of the meeting dates as well as the place.

1st June: GENERAL MEETING.

8th June: Transmitter construction — Power supplies. (At C. Coyle's Home.)

15th June: Club Rooms. Lecture by Mr. E. Walton, on the "Poulsen Arc as an early-day Transmitter."

22nd June: Club Rooms, Lecture by Mr. J. H. Larkin, A.M.I.R.E. Design Engineer, Paton Electrical Pty. Ltd. Special "Questionnaire Lecture" on various types of test equipment.

29th June: Transmitter Construction

(either at C. Coyle's house or at the Club Rooms, depending on progress made at previous meeting).

## THE EXPERIMENTAL RADIO SOCIETY OF N.S.W.

Members of the society were in a reminiscent mood on the evening of May 6th, on the occasion of the 18th Annual Re-union of the Society.

These re-unions are eagerly anticipated by members and on such occasions many old acquaintances are renewed year by year.

Subsequent to the excellent repast provided, the customary toasts were proposed by Messrs. Luckman VK2JT, Picknell, Warren VK2QX, Hayes VK2AJL and Blades VK2VP. These were duly responded to by Messrs. Holt (P.M.G. Dept. Wireless Branch) Sullivan (Gladesville Club), Wilson VK2VW (Kingsford Club), Coyle (Hurstville Club), Jones (St. George Club), and a representative of the Waverley Radio Club; Halworth (A.W. Valve Co.), Hume (Phillips Valves), Hutchinson (W.I.A.), D. B. Knock VK2NO (A.R.W.), W. N. Williams (R. & H.) and C. E. Birchmeier (Radio Science).

A transmitter condenser was won by a representative of the Newcastle Amateurs who spoke of the formation of a new club in that area, the other prize, an 815 tube was won by Mr. A. Appleby VK2BF (W.I.A.).

The next meeting of the Society will take place on May 20th, when the election of officers for the ensuing year will take place.

Miss Sanderson, of Malvern, Vic. submits a fine report, which although a little late for May issue has lost none of its interest. We are pleased to give prominence to many of the stations logged.

**Chile:**  
CE1180 12000kc 9.45 p.m. Chimes on announcement and call clearly spoken.  
CE1190 11900kc 10.15 p.m. Opens at 9.30 p.m. with anthem. News in Spanish.

**Egypt:**  
SUX 7865kc 6.45 a.m. News in Arabic and music.

**Ecuador:**  
HCJB 5999kc 8.15 p.m. Special DX programme, good signal.

HCJB 9950kc 3 p.m. Religious type programme, good one.

HCJB 15110kc 4 p.m. Special DX programme also heard on this frequency.

**France:**  
Paris 9560kc 3 p.m. News in French, fine signal at this time.

**Germany:**  
Munich 11870kc 7.30 a.m. American Newsletter.

Munich 7290kc 7.15 a.m. News in German at this time.

Leipzig 9730kc 4 p.m. News in German, fine signal.

**Guatemala:**  
TGWA 9760kc 2.15 p.m. Fair in Spanish news, call announced on opening and closing.

**Haitii:**  
HH3W 10130kc 10.15 p.m. Good one, now on increased power, news in French.

**Poland:**  
Warsaw 6210kc 6.45 a.m. English news, interval signal of piano notes.

Warsaw 9530kc 4 p.m. Announces as Polski Radio, news and music, same interval signal.

**Palestine:**  
Damascus 12000kc 6 a.m. News in Arabic, good signal.

**Portugal:**  
CQM2 7947kc 8 a.m. Powerful signal, news and music.

**Spain:**  
EAJ3 7037kc 6.45 a.m. "Radio Nacional Espana", male and female announcers, good signal.

**Sweden:**  
SBP 11700kc 4.30 p.m. News and music, good signal.

**Switzerland:**  
HEI5 11815kc 1.15 p.m. English news and melodies from Switzerland.

HER5 11715kc 4 p.m. News in French, easily identified.

**South American:**  
LRM 6180kc 8 p.m. Opening at good level, news, etc.

LRR 11880kc 8.30 p.m. Fair signal in Spanish, news, etc.

LRS 9315kc 10.15 p.m. Under interference, but good signal.

ZYB8 11765kc 8.15 p.m. News in Spanish, fair strength.

**Yugoslavia:**  
9420kc 4 p.m. "Radio Belgrade". Female announcer, news in French.

## U. H. F. TECHNIQUES

(Continued from page 36.)

may be too critical to be of any practical value.

Another method of tuning is by means of plugs screwed into the outer walls of the cavity. As they are screwed in, the volume of the cavity decreases and the resonant frequency increases. This method is probably simpler mechanically, although it is not as suitable for dual cavity control as the other method.

### Reflex Klystron Oscillators.

One of the requirements of the original double cavity klystron was that both cavities be tuned to exactly the same resonant frequency. As well as placing close mechanical tolerances on the cavities, this required an elaborate tuning mechanism. This disadvantage led to the development of the reflection or reflex klystron oscillator in 1939 in England, where attention was being focussed on the problem of making oscillators for the 10 centimetre region.

In the reflex klystron a single cavity performs the function of both buncher and catcher. By providing a reflector or repeller electrode at a negative potential, the electron beam, after passing through the cavity and becoming bunched, is reversed and returned through the same cavity which then acts as a catcher.

Figure 5 is a sectional view of the English CV35 reflex klystron. A feature of this tube is the absence of any grids. The electron gun consists of an indirectly heated cathode with a focussing electrode together with a cathode screen. This is connected to a separate pin on the base and may be used in modulating the output.

The rumbatron resonator consists of two portions, one inside and the other outside the glass envelope. The former consists of two copper spun diaphragms 0.010 inch thick, sealed to the glass and projecting outside the envelope, whilst the cavity is completed by a hollow cylindrical piece of metal to which the diaphragms are clamped. In production the outside resonator parts were made of diecast metal and were plated with copper and gold.

Tuning of these tubes is by means of plungers screwed into the outside wall of the cavity—two for coarse tuning and one non-contacting type for fine control. A frequency range of 6-8 per cent. is available with these controls. Power is taken out by means of a loop coupled into the cavity. Instead of grids across the centre portions of the resonators, the CV35 has small single holes, and the electrons are focussed into a very narrow beam. An essential in the construc-

tion of this type of tube is accurate centring and alignment of the electrodes.

The output at 10 cm. is about 400 milliwatts for a current drain of 10 milliamps and an efficiency of about 3 per cent. For good frequency stability a well regulated power supply is essential.

Towards the end of the war reflex klystrons for K band (about 1.2 cm) were developed in England and America. Some of these are illustrated in Figure 6.

### High Powered Klystrons.

Recently the Sperry Co. has developed high power reflex klystrons for communication applications. Power outputs of 4.5 watts are available from tubes operating at frequencies up to 8,000 Mc/s. One of these tubes is illustrated in Figure 7. This is a type SRC8 suitable for the range 5,500 to 7,800 Mc/s.

Another application of the klystron in communication and relay work is an r.f. amplifier.

### Modulation.

For communication it would be necessary to modulate klystrons. Both amplitude and frequency modulation is possible with klystron oscillators. For amplitude modulation a control grid is required. The CV35 is provided with a cathode screen for this purpose. A certain amount of frequency modulation accompanies amplitude modulation by this method.

Frequency modulation is obtained by means of a variation of either the accelerating voltage or the reflector voltage. This is accompanied by amplitude modulation. By a combination of both the above methods the unwanted modulation may be eliminated and pure amplitude or pure frequency modulation obtained.

In conclusion, it may be pointed out that the klystron, which has had a much shorter and less varied history than the magnetron, is not capable of such high efficiency as the magnetron, but is more easily tuned and more suitable for low power CW operation.

### BIBLIOGRAPHY

R. H. Varian and S. F. Varian—*A High Frequency Oscillator and Amplifier, Journal of Applied Physics, Vol. 10, Pp. 321, 1939.*

A. F. Pearce and B. J. Mayo—*The CV35 Velocity Modulation Reflection Oscillator, Journal of Inst. of Electric. Engin., Vol. 93, Pt. IIIA, Pp. 918, 1946.*

J. D. McNally and W. G. Shepherd—*Reflex Oscillators for Radar Systems, P.I.R.E., Vol. 35, Pp. 14-24, 1947. BSTJ.*

*Klystron technical Manual published by the Sperry Gyroscope Co. (This book contains a copious bibliography.)*

## ELECTRONICS IN INDUSTRY

(Continued from page 11.)

shears except when the operator's hands are out of the way.

In similar fashion interrupted light beams can be made to operate burglar alarms, detect smoke and fire, stop machinery when over-travel occurs.

Traffic signals at highway intersections can be arranged to count the number of vehicles on each road and allocate the green clearance time in proportion to the density of traffic on each intersecting highway.

### Quality Control.

Many of the devices already described are also used in the final quality control of manufactured goods. The greatest electronic advance in this direction is perhaps increased employment of X-ray radiographic inspection. Production parts may be rapidly checked for internal faults and micro film records kept. A typical production arrangement using this technique is shown in Figure 11.

Recent advances in industrial X-ray have produced a thickness gauge for sheet metal rolling mills. In this system, the absorption of X-rays by a standard thickness of metal is compared with the absorption obtained in an identical manner from a moving strip of the same nominal thickness. Variations in thickness give rise to corresponding variations in absorption. The electrical quantities developed by the effect of departures from standard thickness may be amplified and used to screw down or open rolls to correct errors. This device detects and correct thickness variations so rapidly that the strip mill can operate at a linear feed velocity of a mile a minute!

### Scope for More Industrial Uses of Electronics.

The cross section of typical industrial electronics application just described is but a small sample of the vast pattern of the science as it affects industry today. Yet many more fundamental contributions will surely be made in the next few years as scientists get down more and more to the real needs of industry and as the present important research programmes reach maturity.

Most problems being solved to-day involve the dovetailing of separate but well proven principles integrated in a different manner to meet new requirements. As each new fundamental contribution is added, it increases very greatly the possible permutations and combinations of arrangements available to meet the increasing diversity of applications of the science of Industrial Electronics

\*All Photographs supplied by courtesy Westinghouse Rosebery Ltd.

# The Mail Bag

**M.E.M. (Bordertown, S.A.)** after seeing the first two issues has decided to become a permanent subscriber and enclosed a two-year subscription.

**A.**—Your subscription is appreciated and this has been attended to by our Subscription Dept. As you say, the subject of acoustics is a very involved science and it is hard to do it justice in just one or two general articles. We intend keeping your suggestion in mind, and as soon as the opportunity (and time) permits, we hope to do something about speaker baffles, etc., along the lines you mention.

**W.J.H. (Malvern, Victoria)** appreciates the recent list of Service Valve Equivalents, and suggests that an article dealing with Grounded Grid RF amplifiers should be topical.

**A.**—Your suggestion has been noted, and it may be possible to publish details of this type of circuit. Its use is now becoming more widespread and agree that it should be of interest to most amateurs. Thanks for the appreciative remarks.

**E.B.H. (South Yarra, Victoria)** asks about forwarding technical articles for publication.

**A.**—Technical articles of the type you mention will always be considered for publication in the magazine. If you care to forward them along, we will advise you of their suitability or otherwise. If accepted for publication, you will be paid for them at our current rates for such material.

**F.E. (Alphington, Victoria)** suggests we publish an article dealing with the construction of a tape recorder.

**A.**—Although no doubt such an article would be interesting, the main drawback at the moment is the availability of suitable components. For instance, it would be difficult to obtain suitable electric motors and as far as we know the special type of magnetic tape required is not yet available in quantity in this country. Under such circumstances an article of this type would only have a limited appeal, although it may interest some manufacturer in the possibility of this type of equipment.

**K.McK. (Bondi Junction)** has read all constructional articles to date with great interest and hopes to try some of these circuits in the near future.

**A.**—Thanks for the interesting letter. The Dual Wave Seven described in the May issue will probably suit your purpose, although it is somewhat larger than the type you suggest. We are pleased to hear of your friend's success with the Miniminor Portable—excellent reports have already been received from many other centres regarding this small receiver. A pickup could be fitted to the commercial receiver you mention, although the

## TECHNICAL QUERY SERVICE

Readers are invited to send in any technical problems either dealing with our circuits or of a general nature, and an earnest endeavour will be made to assist you through the medium of these columns. For convenience, keep all letters to the point, with questions set out in a logical order, as space is rather limited.

All technical enquiries will be dealt with in strict rotation and the replies will be published in the first available issue of the magazine. Address all letters to RADIO SCIENCE, Box 5047, G.P.O. SYDNEY, and mark the envelope "Mailbag".

results would not be particularly satisfactory in view of the small size of the speaker. Probably the best place to connect this would be by arranging a switch in the diode load circuit. This would mean that the pickup would feed directly into the 6V6G grid—not a very efficient arrangement, but still workable especially if a high output crystal unit is used.

**J.E.H. (Mt. Isa, Q'ld.)** asks if Geiger-Muller tubes are available for private use.

**A.**—To the best of our knowledge this type of tube is not yet commercially available to the general public. Most of the tubes imported into this country are mainly for use in the various Government and other scientific laboratories.

**R.M. (Moorooka, Brisbane)** is interested in hearing aid circuits and asks if we can supply these.

**A.**—Unfortunately, we have no circuits of this type on hand, and consequently cannot offer you much assistance. It should be remembered there are many forms of deafness, and the circuit that suits one type may be entirely unsuited for another person. Because of this it is preferable to obtain competent advice before using such a unit, otherwise it is possible to actually do more harm than good.

**B.C. (No Address)** sends in several suggestions.

**A.**—A page of standard technical information as you mention would certainly provide a handy reference chart for the beginner. We will examine the possibility of drawing this up, and if feasible will certainly include it in a future issue. Test equipment will also be described from time to time, and no doubt you will see the article you require in later issues. Your remarks concerning the magazine are appreciated.

**R.G.J. (West Hobart, Tas.)** writes: "Having found much interest in your first and second editions of RADIO SCIENCE, I have

constructed the Low Cost Amplifier which was featured in your first issue. The amplifier is housed in a rather robust box together with a 12 inch speaker, and I can assure you that the results from record reproduction in my opinion are unequalled . . ."

**A.**—Thanks for the letter, R.G.J., and we are pleased to hear of your success with the small amplifier. There have been several enquiries for the larger tuner unit, and it is hoped to feature something along the lines you suggest in an early issue.

**A.M. (C/o. Post Office, Wagga)** is interested in the Fremodyne FM circuit described in the March issue of RADIO SCIENCE, and requests some additional information.

**A.**—This particular article was based on an overseas report and consequently is the only information we have regarding it. Since it is a Hazeltine patented circuit, no details of the tuning condensers or coils were included. The valve used in the circuit is the dual triode 12AT7—a type not yet available in this country.

**J.B. (Marrickville, N.S.W.)** asks several questions regarding the fitting of an extension speaker to his present set.

**A.**—There should be little difficulty in wiring in the extra speaker, and for preference this should be a permanent magnet type. This means that only two leads will be required as against the four needed in the case of the electro-dynamic type, and also there will be no field excitation troubles. The accompanying diagram will assist in making the correct connections, and this arrangement will permit either or both speakers to be operated simultaneously, without any serious mismatching. The output transformer should be suitable to match the two voice coils in parallel, i.e., have half the normal secondary impedance. The switches are single pole double throw type and operate so that when one speaker is disconnected, a dummy load is connected in its place. The value of this "R" should be approx. 25% greater than the voice coil impedance, and capable of dissipating at least half the maximum power output of the receiver. Although some power is lost in the resistor when only one speaker is operating, the correct load impedance is maintained resulting in correct operating conditions and minimum of distortion.

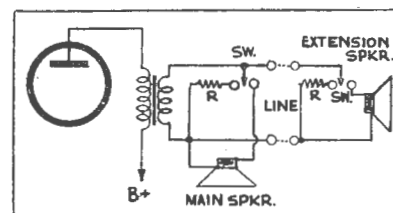



R.J.N. (Cessnock West) writes an appreciative letter and includes several suggestions for the magazine.

A.—Many thanks for your letter, R.J.N. It was read with great interest. We would be pleased to hear of your results with the "Signal Tracer" as soon as you complete it. The Service Data Sheets will continue as a feature and we agree on their value to the serviceman. You may care to contribute some of your own servicing problems to the section "For Your Notebook," as undoubtedly many other readers would be interested in them. Although the policy of the magazine is restricted to only the radio and electronic field, it is possible that details of constructing suitable cabinets would not go amiss. We would be pleased to see the photographs of your own efforts in this direction whenever you find time to send them along.

C.E.R. (Neutral Bay, N.S.W.) forwards a subscription and writes: "I have been obtaining copies of RADIO SCIENCE since publication commenced and consider it to be Australia's best radio magazine, and am becoming a subscriber so that I shall not miss future copies. It is my idea of what a radio magazine should be and hope future issues will continue to contain items especially suited to the average hobbyist on varying subjects. . . . The magazine's present standard is wonderfully high and I look forward to following your programme of advancement . . ."

A. Thanks for the subscription and appreciative remarks. You may rest assured that future issues of RADIO SCIENCE will maintain or better the present standard. Your suggestion regarding the test equipment articles has been noted, and it is anticipated that something along these lines will appear in an early issue.

R.A.K. (Wellington City, N.Z.) writes an appreciative letter and being an Official DX Listening Post is specially interested in the Short Wave pages.

A. Your letter is appreciated, and pleased to hear you enjoy reading RADIO SCIENCE. As we are now including a page of N.Z. news you may care to contribute some items to our correspondent, Mr. J. Fox. Should you have any difficulties obtaining future copies, why not subscribe direct to us? The rates are 12/- per year, or 21/- for two years, both including postage to your address. New Zealand Money Orders are negotiable in this country, and you should have little difficulty on obtaining this from your local Post Office.

L.S. (Albert Park) acclaims the magazine and is particularly interested in amplifier circuits.

A. We note your interests in audio equipment and would be pleased to hear of your experiments with the speaker network data you contemplate trying out. The article on "Baffle" design has been suggested by several other readers, and we will endeavour to publish an article on this topic. The Car Radio is also receiving consideration—however, in the meantime the Caravan Five in this issue may interest you since it can be operated from a 6.0 volt battery.

A.E.W. (Booker Bay) draws our attention to the very obvious error in the "Ohm's Law Reference Card" shown in the "For the Experimenter" page in the May issue of RADIO SCIENCE.

A. Yes, A.E.W., you are quite correct. The first formula in the "R" quadrant should read E/I and not as E/R as shown. Apparently irrespective of the amount of checking and re-checking, even the most obvious mistakes (afterwards) still often slip by.

W.H.W. (Waverley, N.S.W.) intends building up the Signal Tracer described in the April issue, and asks whether an O-1 Milliammeter could be used in this circuit.

A. The meter you have on hand will be suitable for this circuit, since it is only intended to provide to visual indication of relative signal strength, and not any particular voltage or current reading. We would be pleased to hear of your results with this equipment.

G.L.S. (Albert Park) suggests that we publish underneath wiring diagrams of all circuits described.

A. As your letter is the first one in several hundred to mention this subject, it appears most likely that these wiring diagrams are not popular or required as is often expected. We have purposely refrained from publishing them, since all necessary information is given in the schematic diagram, and this coupled with the many excellent photographs of the completed receiver is generally sufficient for the average home set constructor. In view of this, we consider the extra space required for these diagrams can be put to better use by providing additional reading matter.

F.M. (Strathfield) recently bought his first issue of RADIO SCIENCE and is appreciative of the scope of the contents.

A. Thanks for the interesting letter, F.M. We are pleased to hear you enjoy reading the various articles. If you require the first two issues of the magazine these are now available from our Subscription Department, price 1/- each, post free.

A.B. (Queenstown, Tasmania) sends along a subscription and suggests that an article dealing with intercomm. systems be published.

A. Thanks for the suggestion and subscription. We realise the increasing popularity of this form of office intercommunication, and will try and include some details as well as circuits in an early issue. The small speakers you mention would be quite suitable for use, and could operate as both a speaker and/or microphone, by using suitable switching.

K.R.M. (Camberwell, Victoria) sends along details of a valve circuit tester which he finds very useful in service work.

A. So far we have not had the opportunity of looking very closely at this circuit, but will keep it by for future reference. At first glance it seems as though it could be useful around the service bench. Your remarks concerning the magazine are appreciated.

R.W. (Ascot, Brisbane) is a radio mechanic in the Australian Regular Army, and would like to see some articles dealing with general receiver fault finding.

A. Your suggestion has been noted, and it may be possible to provide some information of this type. However, in the meantime "For Your Notebook" and the page of service data included in this issue should be of some interest. We appreciate the subscription, and trust your promotion comes along as anticipated.

#### ANSWERS TO QUIZ

- A.1 (b) They are usually referred to as the E and F layer.  
A.2. (d) Theoretically waves of any length can be transmitted through a wave guide. Since the dimensions of the guide increases rapidly with a decrease of frequency, it is only practicable to "pipe" the very high frequency waves.  
A.3. (a).  
A.4 (b).  
A.5. (c).  
A.6. (a) and (b) are the correct answers although (d) would also warrant some marks since it is bound up with (a).  
A.7. (d).  
A.8. (b).  
A.9. (b).  
A.10 (c).  
A.11 (c).  
A.12 (c).  
A.13. (b).  
A.14. (a) and (c).  
A.15. (b).

#### ALL WAVE BATTERY TWO

(Continued from page 29.)

an overlap on the first coil and it covers from 8 to 2.5 Mc—that is approximately 37.5 metres to 120 metres.

As mentioned earlier, it is rather difficult to wind two sets of identical coils by hand, and, in addition, the actual coil coverage and set operation is governed to some extent by associated components. Because of this it may be necessary to experiment with the coils to achieve maximum results.

For example, if a receiver proves in practice to be lacking in selectivity, then try moving the position of the tapping on the coil. This will improve the selectivity but at the same time may result in a slight loss of gain, so here some form of compromise may be necessary.

Then again if the set does not oscillate properly over the entire band the sensitivity will be poor and it will be generally impossible to hear code signals. If it is found that the receiver does not oscillate near the low frequency end of the band, then the reactions turns should be increased, or moved slightly closer to the grid winding may assist. On the other hand if the reaction is uncontrollable, it may be necessary to remove turns, increase the distance between reaction and grid windings, or reduce the applied voltage.

If the set does not oscillate at all, then the most likely cause is incorrect reaction connections, and the cure in this case is to simply reverse the two leads.

# If you have a measurement problem . . . . .

THEN A.W.A. HAS A  
PRECISION INSTRUMENT  
TO MEET YOUR NEEDS

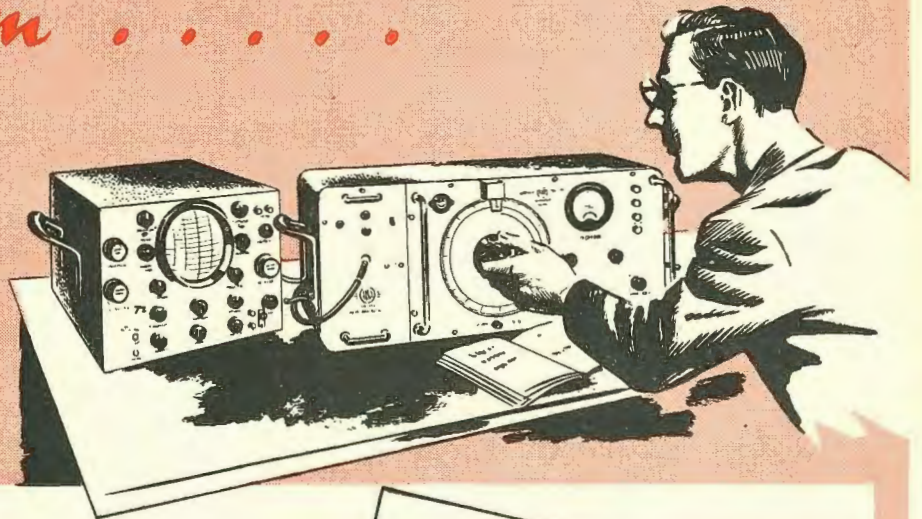

For over a quarter of a century, A.W.A. Laboratories have been producing a wide variety of precision electronic instruments designed essentially for research and industry.

A large staff of engineers is constantly engaged in the development of new and improved types of test instruments to meet wider ranges of application.

A.W.A. offers the choice of a far greater range of apparatus than ever previously available in Australia. In addition, a representative selection of high quality instruments by Marconi Instruments Ltd., England, is available.

An invitation is extended to Electrical and Radio Engineers, Designers and Manufacturers to call or write and discuss any measurement problem with the Company's Test Instrument Engineers.

*The following represents the more important instruments normally stocked . . .*

- Beat Frequency Oscillators
- Cathode Ray Oscillographs
- Signal Generators
- Audio Frequency Meters
- Output Meters
- Q Meters
- Valve Voltmeters
- Decade Capacitance Boxes
- Decade Resistance Boxes
- Impedance Matching Equipment
- Moisture In Timber Meters
- pH Meters
- Distortion Factor Meters

*Descriptive literature available upon application.*



**AMALGAMATED WIRELESS (A/SIA) LTD.**

*Australia's National Wireless Organisation*

47 YORK STREET, SYDNEY ..... Telephone B 0522

167 QUEEN STREET, MELBOURNE ..... Telephone MU 9161

---

**AUSTRALIA'S FINEST SPEAKER**

Only in Rola Speakers will you find all the most modern features of speaker construction. Illustrated is Rola model 8M, a highly efficient eight inch speaker with a generous-sized magnet of Anisotropic Alnico and an Isocore transformer.

Retail price £2.6.3

Available through all Rola distributors.

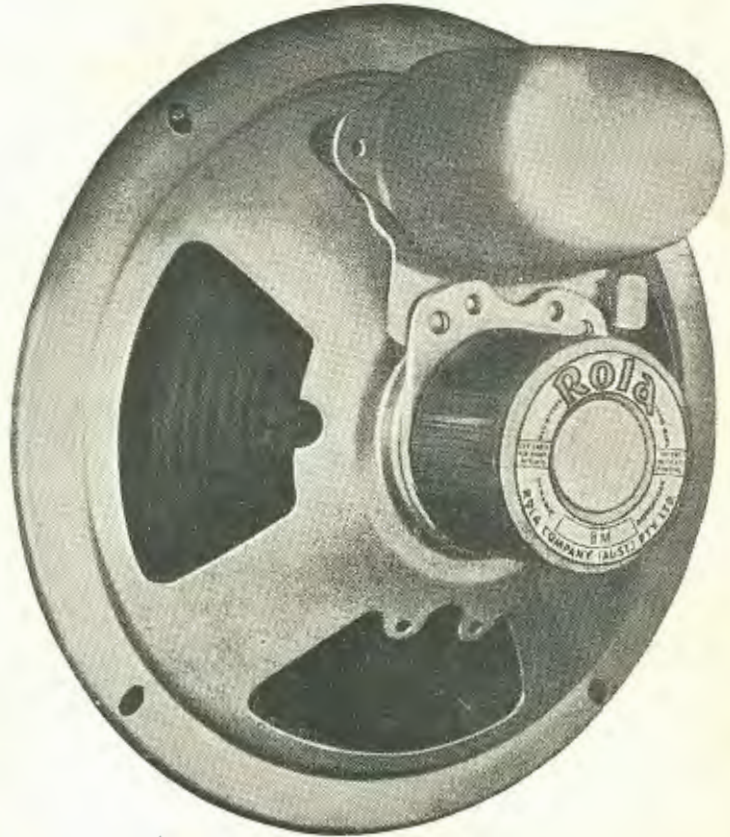

# Rola

**LOUDSPEAKERS WITH ANISOTROPIC ALNICO**

Rola Co. (Aust.) Pty. Ltd., The Boulevard, Richmond, Victoria  
and at 116 Clarence Street, Sydney, New South Wales