

THE
AUSTRALASIAN

Registered at the G.P.O.,
Sydney, for transmission
by post as a periodical.

Radio World

1/-

VOL. 12 NO. 5

OCTOBER 15, 1947

YOUR GUARANTEE OF QUALITY

Warranty

ROLA COMPANY (AUST.) PTY. LTD. will make good or replace at the factory any Rola products which, by examination at the factory made within both ninety days from the date of sale and twelve months from the date of manufacture, are proved to the satisfaction of a representative of the Company to have failed to correspond with the description or to have been defective in material or workmanship. Save as aforesaid all conditions and warranties as to description, quality, state, conditions or fitness of the Company's goods are expressly negatived and the Company neither assumes nor authorises any representative or other person to assume for it any other obligation or liability in connection with the sale of any goods manufactured by it.

ROLA

Makers of

- ★ Rola Loud Speakers
- ★ Magnet Winding Wire
- ★ Magnet Alloy Steels

ROLA CO. (AUST.) PTY. LTD.
Makers of the World's
Finest Loud Speakers

ROLA COMPANY (AUST.) PTY. LTD. The Boulevard, Richmond, Victoria

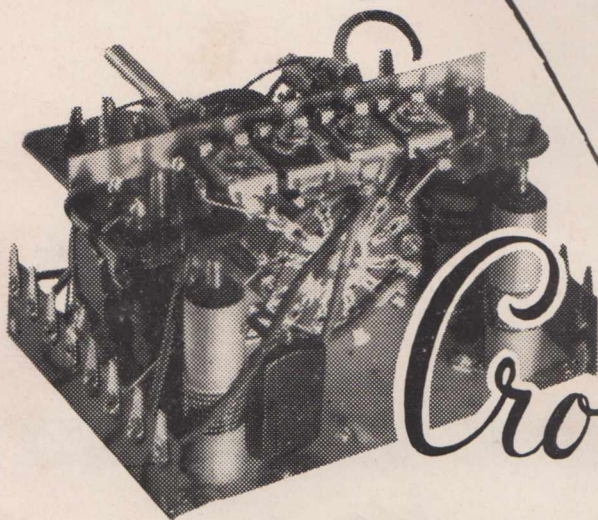

To Be Released
Shortly!
The "FECO" Series
of new
Miniature Coils
and I/F Transformers

Crown DP 3A

TUNING UNIT

B/C AND S/W 13 TO 42 METRES

This unit incorporates iron cored coils for both B/C and S/W bands. Each band consists of aerial R/F and oscillator coils. Inbuilt, fixed Padder condensers are incorporated, Padder adjustment is by the iron core in the oscillator coils. The use of iron cores in the S/W coils ensures better tracking as the inductance of each coil can be individually adjusted. This will give you more efficient overall performance.

PRICE, £4/17/- Including Sales Tax

Crown



RADIO PRODUCTS PTY. LTD.

51-53 MURRAY ST.
PYRMONT, SYDNEY. TELEPHONE: MW 2628

THE AUSTRALASIAN RADIO WORLD

Devoted entirely to Technical Radio

and incorporating
ALL-WAVE ALL-WORLD DX NEWS

- ★ EDITOR
- ★ PUBLISHER
- ★ PROPRIETOR—

A. G. HULL
Balcombe St., Mornington,
Vic.

- ★ SHORT-WAVE EDITOR—

L. J. KEAST
6 Fitzgerald Road, Ermington,
N.S.W. Phone: WL1101

- ★ HAM NOTES By—

D. B. KNOCK (VK2NO)
43 Yanko Av., Waverley, N.S.W.

- ★ ADVERTISING
REPRESENTATIVE FOR VIC.—

W. J. LEWIS
20 Queen St., Melbourne
Phone: MU 5154

- ★ ADVERTISING
REPRESENTATIVE FOR N.S.W.—
AMALGAMATED PUBLICATIONS
PTY. LTD.

83 Pitt St., Sydney
Phone: B 1077

- ★ SUBSCRIPTION RATES—

6 issues 5/3
12 issues 10/6
24 issues £1
Post free to any address in
the world.

Address for all correspondence:
AUSTRALASIAN RADIO WORLD

Balcombe St.
Mornington
Victoria

Vol. 12

OCTOBER, 1947.

No. 5

CONTENTS

| | |
|------------------------------------|----|
| CONSTRUCTIONAL— | |
| "Snug 5" | 5 |
| TECHNICAL— | |
| Kingsley Equipment for U.H.F. | 11 |
| Adjusting the Dipole | 27 |
| "Rural 4" | 15 |
| Servicing by Signal Tracer | 29 |
| Calling "C.Q." | 33 |
| SHORTWAVE REVIEW— | |
| Notes from My Diary | 38 |
| THE SERVICE PAGES— | |
| Answers | 42 |

EDITORIAL

It is indeed pleasing to note that the P.M.G.'s department has recently made certain minor changes in its rules and regulations which will be well received by amateurs.

First there is the dropping of the expression "experimental" in connection with the station licence. Hams are now officially "Amateur Station Licensees."

The power limit has now been raised to 100 watts all round and no probationary period necessary for new licensees.

More than ten years ago I made several drives for a lifting of the power limit, but it was officially considered to be quite impossible. Now it has at last been found possible, so hams are a lot happier these days.

Some radio traders are not so happy in their contact with the P.M.G.

There is a regulation that dealers must send in a monthly report giving the name and address of each buyer of a radio receiver. There does not, however, appear to be a regulation which can force the buyer to reveal his name. Apparently anyone can walk into a radio shop with the pound notes in his hand and demand to be served with a radio receiver. What dealer could refuse to take the money? Yet where does he stand if the buyer hurries out of the shop muttering about having to rush to catch the tram?

If the P.M.G.'s department can't manage to collect their own licence fees without the aid of the radio trade it seems apt that they should offer the trade at least 10 per cent. commission and let them do the collecting!

—A. G. HULL.

Here's the Coil Kit for Your "PERSONAL" RADIO

The restricted dimensions of the construction and layout of a personal radio demand components of the highest quality and performance. These factors have a greater reflection on the final performance than in any other type of chassis.

R.C.S. components are in conformity with the very latest developments of personal radio design.

Specify R.C.S. components from your retailer. This guarantee is that your personal radio will have comparable performance with that produced in any part of the world.

This personal Coil Kit Type K118 consists of—

Below—1 Midget oscillator coil suitable for use with 6A8 6J8—1R5 valves. Type E354.

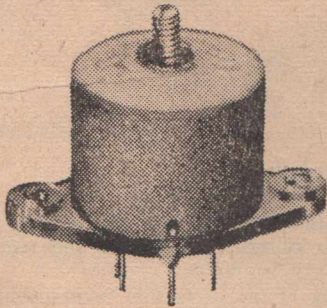

2 Miniature Intermediate Transformers Type IF168 (not illustrated).

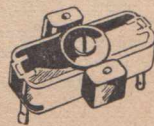

Above—1 Padding Condenser Type P21.

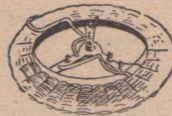

Above—1 Loop Aerial, Type F125.

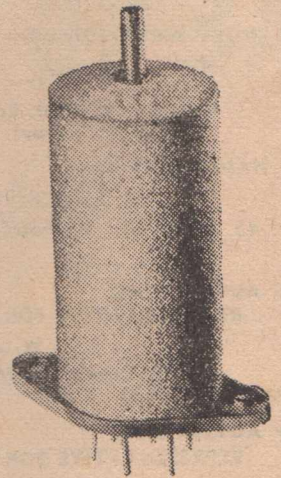

Above—Iron clad R.C.S. Magnasonic Coil.

R. C. S.
RADIO PTY. LTD.
174 Canterbury Rd.,
CANTERBURY

These kits are available from your local retailer. Contact them NOW for full particulars and specifications.

"SNUG 5"

Featuring R.C.S. "Magnasonic" Coils

THE R.C.S. coil people have been making good coils for a great many years. It must be about fifteen or sixteen years ago that they first turned out a super-het coil kit which was outstanding in its day. Ever since that time we have been in close contact with Mr. Ron Bell, managing director of R.C.S. Radio Pty. Ltd., but the ter-

By

A. G. HULL

rific programme of vital work which was done for the Ministry of Munitions made it impossible for R.C.S. to make an early release of their latest types of coils, which are not only iron-cored but also iron-cased. Experimental work was started on these before the war clouds gathered, and research work on them has been carried on right through, but only now have the

coils been made available at last. As may be expected from a firm with such a background of success-

ful experience in coil design and manufacture, the new R.C.S. coils have remarkably fine performance.

It has long been recognised that the use of a core of iron-dust inside a coil gives it greater efficiency, and iron-cored aerial coils and intermediate transformers have been popular for years past. The latest R.C.S. coils go one step further, with the coils built into a "can" made up from moulded iron powder, instead of the old-style aluminium can. This design gives the coils greater efficiency and keeps their field to the smallest dimensions, so that smaller sizes can be used without reduced efficiency. Those who have handled some of the midget intermediate transformers which are now on the market will realise that these units

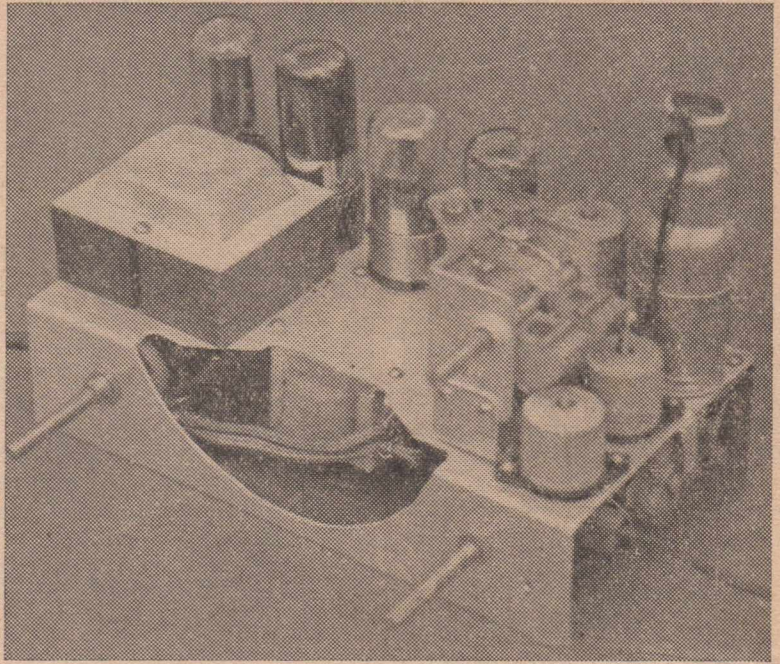

Front view of the experimental chassis

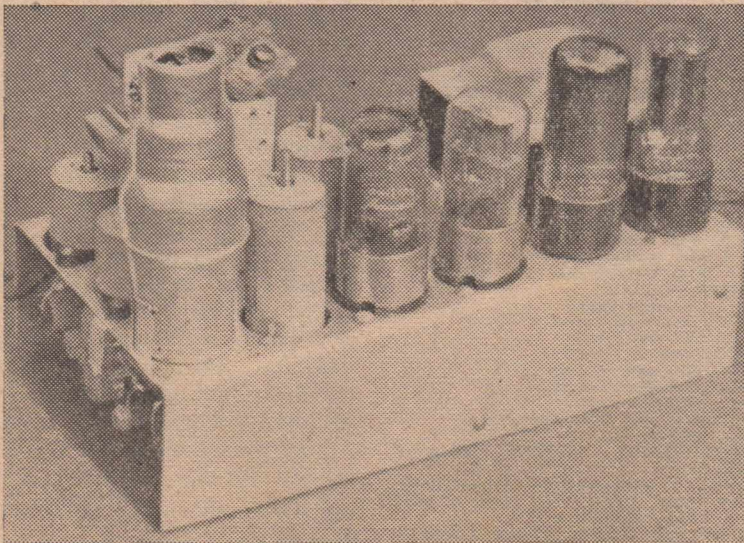

Rear view, showing the valve line-up.

(Continued on next page)

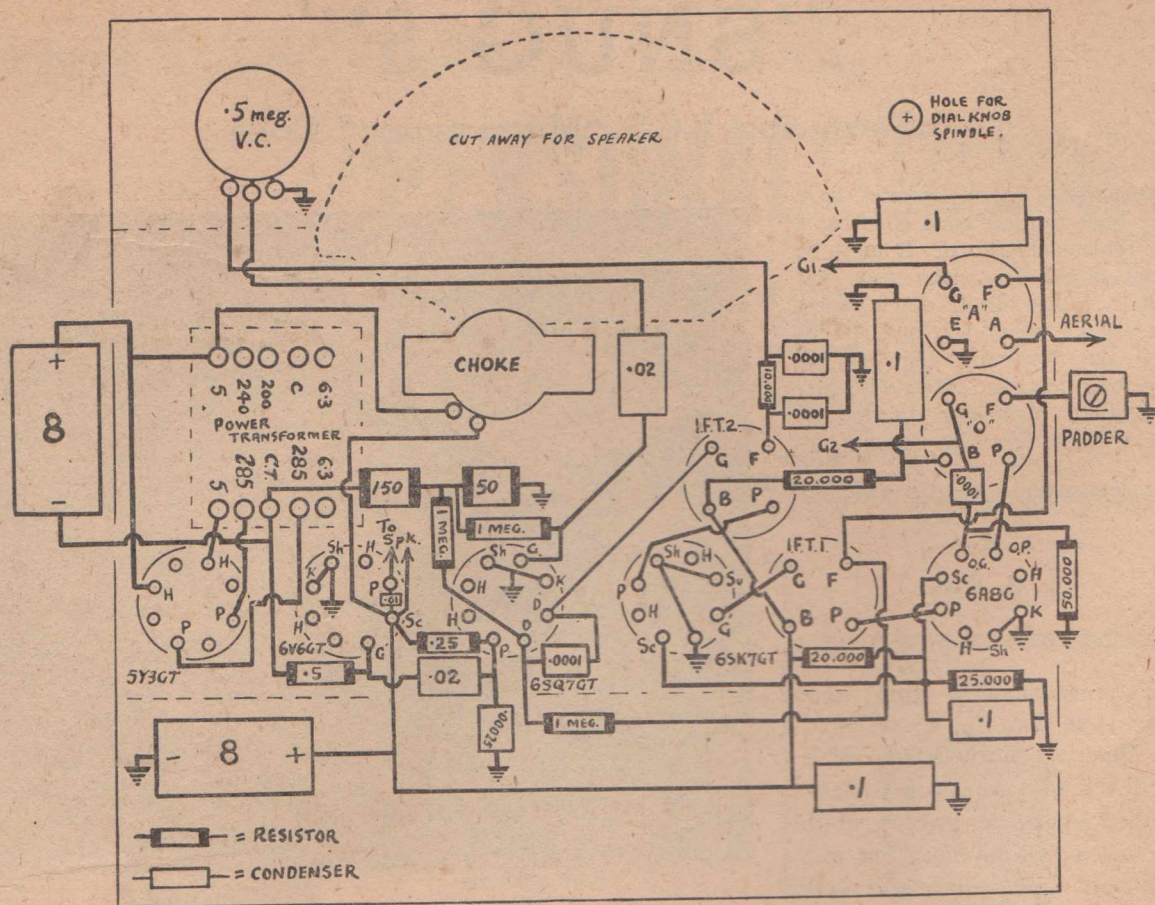

Picture diagram of the wiring and lay-out of the original chassis.

have nowhere near the same gain as obtainable with full-sized components. But the latest R.C.S. intermediate transformers, although of small size, have normal gain. They are not quite as small as some, being one inch in diameter, but this is only an eighth or a sixteenth of an inch larger than the smallest. The difference in efficiency is out of all proportion to the increased size.

Having received samples of the new R.C.S. coils recently, we set about running together a five-valve mantel model to try them out. This set was an experimental set-up, done on a sheet aluminium base. It was not finished in the same way as can be done by the kit-set people who make up three or four experimental models before finalising layout and chassis design. How-

"SNUG 5"

PARTS LIST

- 1—Base, size 9 x 4½ x 2".
- 1—Aerial coil, R.C.S. Magnasonic type E352 midget.
- 1—Midget oscillator coil, R.C.S. type E354.
- 2—Intermediate transformers, R.C.S. type IF168.
- 1—Padder, R.C.S. type P21.
- 1—2-gang midget condenser (Kingsley).
- 1—Power transformer (Trimax).
- Condensers:—
- 4—.0001 mica.
- 1—.00025 mica.
- 2—.01 mfd. tubular.
- 1—.02 mfd. tubular.
- 4—.1 mfd. tubular, 400 volt.
- 2—8 mfd. electrolytics, 525 volt.
- Resistors:—
- 1—50 ohm wire wound.
- 1—200 ohm wire wound.
- 3—20,000 ohm 1-watt.
- 2—50,000 ohm 1-watt.
- 1—250,000 ohm 1-watt.
- 1—500,000 ohm 1-watt.
- 3—1 megohm 1-watt.
- 1—500,000 ohm potentiometer.
- Valves, 1 each:—
- 6A8G, 6SK7GT, 6SQ7GT, 6B6GT/G, 5Y3GT/G.
- Sundries: 5 octal sockets, cabinet, knobs, screws, nuts, solder lugs, hook-up wire, valve shield, hardware, etc.
- Speaker: Rola type 5C, complete with input transformer and choke.

ever, we feel sure that many of our readers will be interested to see what this little chassis looks like, and so here are the photographs.

The first aim in the design was to see just how much could be done to improve the accessibility of a mantel model of small size, rather than to see just how small it could be made. This thought was prompted by a glance at a mantel model on a dealer's counter recently. This set was the product of a well-known factory, but was a shocking example of layout muddle. Only one valve could be withdrawn from the set without pulling the chassis out of the cabinet and this was the rectifier valve which was mounted in a horizontal position on a bracket over the top of the power transformer! The

power output valve had its glass envelope within an inch of the speaker cone, and being so tightly crowded in with other components it would be almost certain to cause the speaker cone to warp.

AIM OF DESIGN

So, with a head crammed with thoughts about that particular example of bad layout we set forth to see whether it would be possible to have a small chassis, but with every valve located along the back, so that each would be accessible without taking the chassis out of the cabinet, and where the heat would normally rise out of the open back, avoiding warping of cabinet and speaker.

SUITABLE DIALS

Our biggest handicap was in regard to a suitable small dial, there being practically nothing available in this line. It seems that the dial people are way behind the rest of

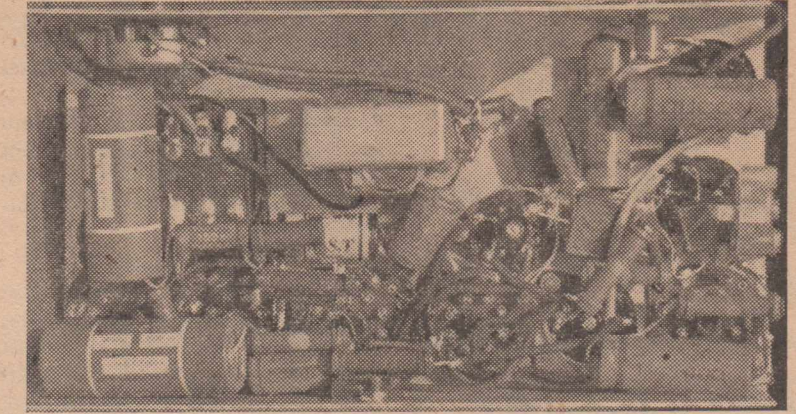

Photograph of the wiring.

the trade in the miniaturisation race. Finally we decided to use a direct-drive knob of large dimensions but this was not fully successful. The R.C.S. coils proved so much more selective than we expected that tuning was just a bit too sharp for a direct-drive knob and so we ended up by moving the speaker forward half an inch, mounting a drum from an old

R.C.S. DA7 type dial on the condenser spindle and driving it with a cord from a spindle below. The speaker then being in the way of using an ordinary escutcheon, the spindle was left to go through the baffle of the cabinet and a pointer was fitted on the outside, and stations marked accordingly. This

(Continued on next page)

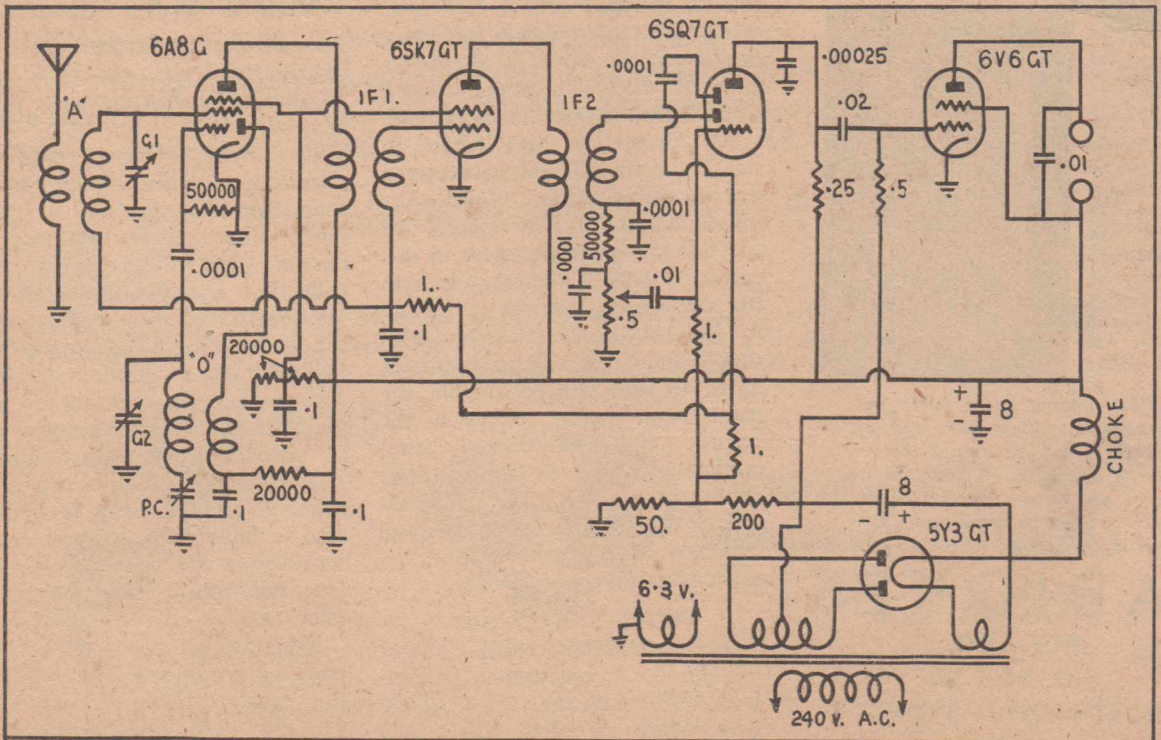

Circuit diagram showing simplicity combined with high efficiency.

Radiokes

**THE NAME
TO KNOW
IN RADIO!**

Radiokes

RADIOKES D.W. UNITS. Highly selective with exceptional wide range. To match 'H' type gang condenser. Incorporates 4-in-1 paddler. Solidly mounted with coils. Ask for type DWO-1

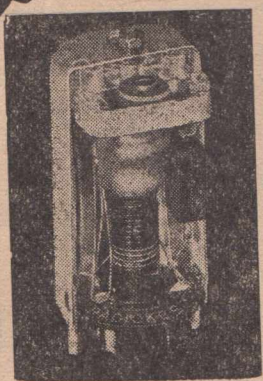

When buying radio parts and components, follow the lead of amateurs and experts alike — specify Radiokes — your guarantee of test-set performance, precision construction and technical excellence.

**RADIOKES
PTY. LTD.
P.O. BOX 90
BROADWAY — SYDNEY**

R-56

"SNUG 5"

(Continued)

made quite a neat little job in the finish. Getting back to the question of size, the base measured 9in. x 4½in., and this gave ample room for a conventional layout without any tricks and sufficient room to make sub-panel wiring a straightforward job.

THE CIRCUIT

For a circuit we did not want to try anything out of the ordinary, but we had in mind an idea that it is easier to get stability in a set which has the cathodes earthed, back bias being taken from the negative high tension return circuit. So we started off by earthing all cathode, shield and suppressor terminals, and this makes the wiring a bit simpler too. For the valve line-up we would have liked to use a complete set of the new GT small-size valves, but we couldn't get one of these in the converter range to suit the coils of which we had samples. At any time now the R.C.S. coils will be available to suit the 6SA7GT, and then it will be possible to build up this receiver with a matched set of GT type valves. The intermediate frequency amplifier is the 6SK7GT, the detector a 6SQ7GT, the output valve a 6V6GT and the rectifier a 5Y3GT.

No precaution was taken to avoid hum trouble and we expected that we would need a 25 mfd. electrolytic across the bias resistor, but this did not prove necessary in this particular case. Other sets built to the same circuits might give hum trouble, but the 25 mfd. condenser should fix it. A voltage rating of 25 or 40 volts will be suitable, the main point being to watch the polarity, the positive end being earthed, contrary to normal filter condenser practice. This is necessary as the centre-tap end is "more negative" than earth, so that the earth takes the positive end.

POWER TRANSFORMER

The power transformer is one of the Trimax miniatures, a particularly well-made and well-designed unit which supplies about 285 volts at 60 milliamperes without any sign of heating up.

SPEAKER

The speaker fitted is the latest Rola permagnetic type 5C, with alnico magnet. This is not the smallest speaker obtainable, the Rola 3C being a much smaller and lighter unit. We used the larger speaker because it can handle greater power. To use the 3C with a 6V6GT on full power is to look for service trouble, as the speaker was never designed for such power. The 5C is capable of handling lots of power and gives excellent reproduction. As will be seen from the photographs, the chassis has been designed with a cut-away so that the speaker will mount snugly among the components, so that the smallest possible cabinet can be used.

CABINET

If time permits a small cabinet will be made up for this set out of scrap timber and masonite, and a description will appear in next month's issue if everything goes off to schedule.



VALVE DATA CHART

By far the handiest and most up-to-date valve chart has just been released by the Amalgamated Wireless Valve Co.

It contains thirty-six pages of classification tables, valve socket connection diagrams and a substitution directory. A most worthy feature is the fullness of the given data. For example, not only are the normal operating characteristics supplied for the 6J7 as an r.f. pentode, but also as an audio amplifier with a plate feed resistor of 250,000 ohms, as a biased detector and as a triode class A audio amplifier.

The substitution directory is invaluable for the radio serviceman who is faced with the problem of repairing a set with valves of a type not readily available at the moment.

You can get your copy of this book by sending a 2½d. stamp to the Amalgamated Wireless Valve Co. Pty. Ltd., 47 York Street, Sydney, mentioning that you are a reader of Radio World.

"Q PLUS" PARADE



NOW AVAILABLE
IN
LIMITED QUANTITIES



THE 3³/₄" POUNDER-MIDGET PERSONAL RADIO KITSET

MEASURES ONLY 6¹/₄" x 4³/₈" x 4⁵/₈"

Amazingly simple to build!! A 4-valve personal-portable incorporating the most modern features in radio—peanut valves—"Q Plus" coils and Midget IF's—Rola 3C Speaker—Minimax Batteries—"Q Plus" flush fitting knobs—plastic aerial, carrying strap, etc., etc. Available as a foundation kit which includes cabinet, chassis, coils and IF's, hardware, instructions, wire, etc. £3/17/6

Or else the full kit, including all the above plus Rola 3C Speaker, Valves, Midget Gang, Batteries, Resistors, Condensers and the new flush knobs £13/3/6

THE NEW "Q PLUS" MIDGET I.F. TRANSFORMERS

MEASURES ONLY 3³/₄" x 3³/₄" x 1⁷/₈"

Ceramicon negative temperature co-efficient condensers.

No. 2 I.F. is more closely coupled than No. 1 in order to overcome Diode loading thus giving 10 per cent. more gain—essential in personal portables. Permeability tuned 13/9 ea.

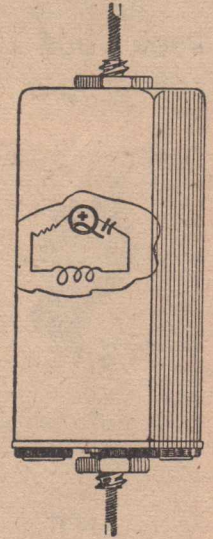

The MIDGET IR5 OSCILLATOR COILS

Specially designed for IR5 Valves and personal portables, giving correct oscillator grid current—coil is wound on grid leak which is actually used in circuit, 4/9 each.

"Q PLUS"

ACTUAL
SIZE



MIDGET
AERIAL & RF
COILS—iron tuned
and impregnated 6/11

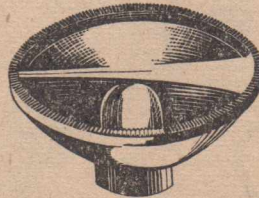

FLUSH FITTING
KNOB,

ALL COLOURS, 1/3

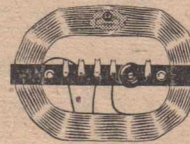

"Q PLUS" MIDGET LOOP

Trolitul impregnated, with aerial load-
ing coil, complete with circuit, 6/11

AND DON'T FORGET THE "Q PLUS" STANDARD I.F.'s AND COILS

R. W. STEANE & CO. PTY. LTD. KEW, VIC.

Ample Stocks

of the

NEW "Kingsley" Speakers

Available from

A. H. GIBSON (ELECTRICAL) Co. Pty. Ltd.

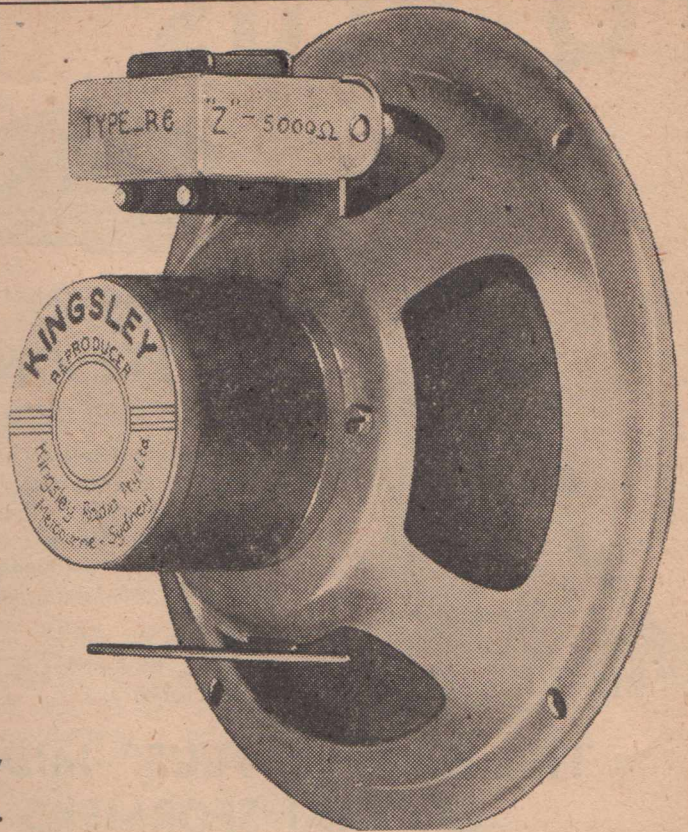

BOOK YOUR REQUIREMENTS NOW
FOR 3 AND 5 INCH SPEAKERS.

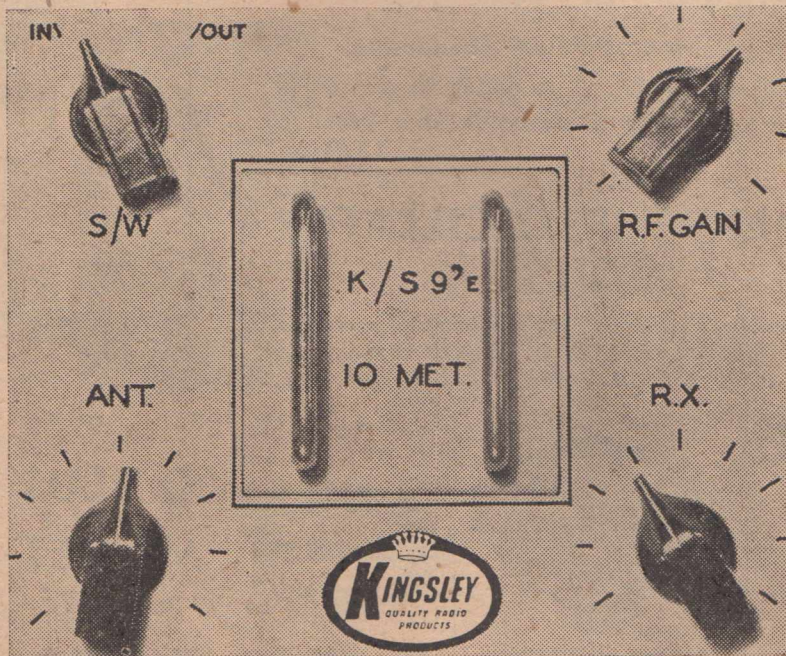

Available in the immediate future — "Kingsley" Ferrotune KF/C610 6 or 10 metre short-wave converter.

Price, £4/5/-.
Plus Sales Tax.

ask for
Mr. F. N. KINNEAR

At left is a ferrotune pre-selector unit type KS9'er. Specially developed for aerial to receiver matching plus high gain and high signal to noise ratio. Covers the 6 and 10 metre bands. Immediate delivery.

Price, £6/6/-.
Plus Sales Tax.

Wired complete with valve.

A. H. GIBSON (ELECTRICAL) Co. PTY. LTD.

416 BOURKE STREET, MELBOURNE

MU 8121 (10 lines)

KINGSLEY EQUIPMENT FOR U.H.F.

Opening a New Field for Enthusiasts

AT the moment, considerable interest is being shown in the ultra high frequencies, it being suggested that frequency modulation transmission and television broadcasting will be done on frequencies of between 30 and 100 megacycles, equal to from 3 to 10 metres in terms of wave-length. Completely new technique is necessary to get satisfactory operation of receivers on these high frequencies, and to make the subject clearer it is well to consider the history of radio broadcasting and note how we have progressively employed higher and higher frequencies.

The early broadcasting stations used a wave-length of from 1500 to 2,000 metres (150 to 200 kilocycles) but although this band was still used by several European broadcasting stations until 1939, its general use was abandoned about 1924. In Australia the original broadcasting was done on the high wave-length, and excellent long-range daylight reception was a feature of this band, but it was not long before the Authorities decided that the general band for local broadcasting would be from 550 to 1,500 k/Cs. (200 to 540 metres). Even when this change was made there was considerable difficulty with instability at the higher frequency, and trouble was especially prevalent at the high frequency end of the band, sets oscillating much more easily at the lower wave-length. It was often found that it was difficult to get uniform gain at both ends of the band, and many regenerative sets were too lively at 1,500 k/Cs. but would not oscillate at all at 550 k/Cs. Technicians tackled the job and soon had aerial coils with both capacitive and inductive coupling to even up the gain, although full triumph over the problem was not obtained until superheterodynes were manufactured, where the main

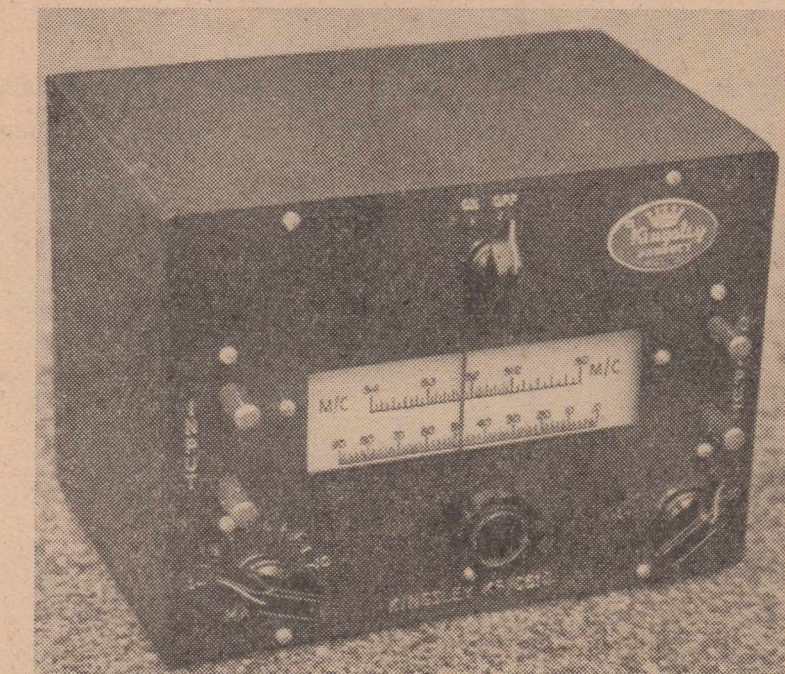

Front view of the Kingsley ultra high frequency converter which is available as a complete unit at a cost of only a few pounds.

gain was done at a low frequency, at about 175 k/Cs. for a start. Later improved types of valves and different intermediate transformer design made it possible to get ample gain and stability with an intermediate frequency of 455 k/Cs.

SHORT WAVES

About 1922 the remarkable behaviour of skipping signals in the higher frequencies received considerable attention and soon we had overseas reception on wave-lengths of from 30 to 80 metres, and later on wave-lengths down to 13 metres. At first the short-wave sets were difficult to handle, unstable in operation, suffered from hand capacity effects, microphonic troubles made them howl, and generally speaking the early short-

wave sets were a first-class headache and many people despaired that they would ever be any better. But again the technicians settled down to the problems involved and it wasn't long before dual-wave sets were available which could be operated by even the housewife. But as you have probably noticed, few dual-wave sets have attempted to handle anything below 13 metres, and plenty of sets are practically useless at any wave-length below 20 metres.

War-time developments have shown that there are uses for much higher frequencies and various radar and other instruments used wave-lengths measured in centimetres. History repeats itself and

(Continued on page 13)

Everyone is very Enthusiastic about the **KS/9'er**...

Since its introduction a few weeks ago, the KS/9 signal-strengthening unit has attracted a lot of interest. Kingsley engineers thought they had something pretty good, but it is even better than they thought—and that is something to take notice of.

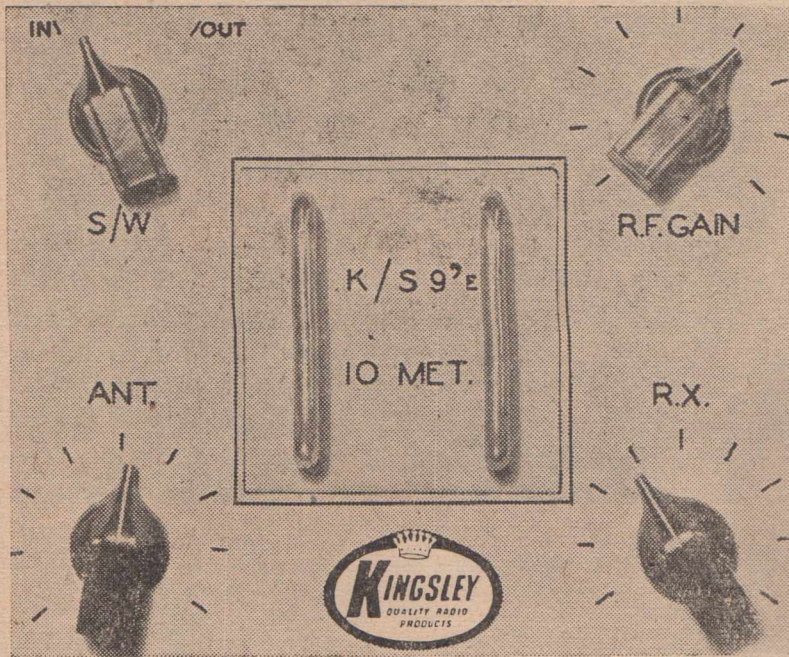

Kingsley's new production programme is a busy one and leaves room only for the best and most useful products—so, for the very best in radio equipment—keep your eyes on Kingsley.



The KS9'er. This unit is designed to bring weak signals to the 9 level. The circuit consists of a system permitting matching to the antenna and to the receiver . . . this match is adjustable. Two inductances for each band are tuned with Iron Cores. A worth-while addition to the "Ham" Station . . . Designed with two coil boxes—one for 10 Metre operation and one for 6 Metre. May be ordered with either or both Coil Boxes.

Obtainable from any Kingsley Distributor



KINGSLEY RADIO

KINGSLEY RADIO PTY. LTD.

380 St. Kilda Road, Melbourne, Victoria . Phones: MX 1159, MX 3653

(Continued)

the normal equipment used on 13 metres is practically useless at 6 metres.

But so as history repeats itself, the technicians are on the job again.

For about ten years past the experimental transmitters have used wave-lengths of five and six metres, so that many "hams" know the many little tricks which are so necessary for ultra high frequency reception. But to the general public the ultras are a closed book.

Now the Kingsley Radio People are setting forth on a campaign to popularise the ultra high frequencies by providing the specialised equipment necessary to ensure satisfactory results. The first item of this line is the KS9'er, which we dealt with briefly in last month's issue. The KS9'er is not a conventional type of pre-amplifier or short-wave converter, but is an aerial coupling unit, which is fitted ahead of a ten-metre or six-metre receiver or converter in order to get proper transfer of signal from the aerial to the grid of the first valve in the receiver. Aerial matching is not so important on the ordinary short-waves, but is vital on the ultras. Likewise the aerial itself is most important. Even the best of receivers and converters will be unsatisfactory unless the right design of aerial is employed.

AERIAL FOR "TEN"

To make a reasonably satisfactory

NEXT MONTH

Another feature on a new Kingsley release.

ORDER NOW!

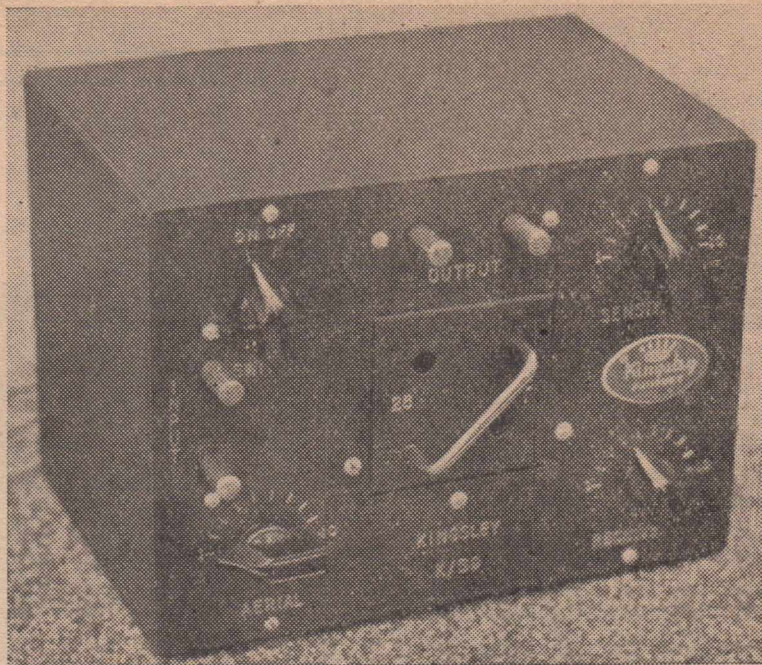

A photograph of the improved Kingsley KS-9'er, which matches the converter in size and shape.

aerial for the ten-metre band the very least is a dipole. To make one of these aerials you take a piece of aerial wire of the correct length, sixteen feet six inches for about the middle of the ten-metre band. Find the middle of this piece of wire and cut it, and insert an egg insulator, so that the two ends of the aerial wire are kept an inch or two apart.

Coupling the aerial to the KS9'er, converter calls for a suitable length of co-axial cable, or pair of twisted wires. The co-axial cable with an impedance rating of 72 ohms is fairly readily available from those shops which deal in disposals equipment, but should any trouble be encountered, a suitable substitute can be made up from two lengths of V.I.R. wire, either 16 or 18 gauge, twisted together with five twists to the foot. This V.I.R. wire is the stuff normally used for running inside the conduit of house wiring circuits for the electric light supply. It can be purchased readily at almost any electricians.

The ends of the two pieces of

aerial wire are connected (soldered joints, please) to the two ends of the twisted pair or to the two sides of the co-axial cable (inside and outside), after due precautions have been taken to ensure a satisfactory mechanical job, so that the joints will not be under stress as the aerial swings in the breeze. Probably every reader will have his own ideas of how to arrange this, but the neatest job we have noticed was one where two egg insulators were used with a piece of cord to take the load, whilst the ends were taken loosely to the ends of the aerial wires. The aerial is mounted horizontally, as high as reasonably possible and clear of roofs and obstacles.

FOR SIX-METRES

An exactly similar design of aerial is suitable for the six-metre band, but the length of wire used for the aerial should be about eight

(Continued on next page)

(Continued)

feet ten and a half inches long to suit the middle of the ham band.

THE KINGSLEY CONVERTERS

Two models of Kingsley converters are to be released in the near future, one for ten metres and the other for six.

Those who remember days of short-wave reception will recall that one of the most satisfactory methods of obtaining good results on short-waves was by means of a converter. The incoming signal is fed to the grid of a suitable converter valve, with its oscillator section tuned to a frequency differing from the frequency of the incoming signal by the right amount to make the output of the converter suitable for amplification by a broadcast or dual-wave set. Sometimes the high frequency end of the broadcast band is used, such as 1,550 or 1,600 k/C. Thus a broadcast band set can be used to form what would be the intermediate frequency amplifier of a conven-

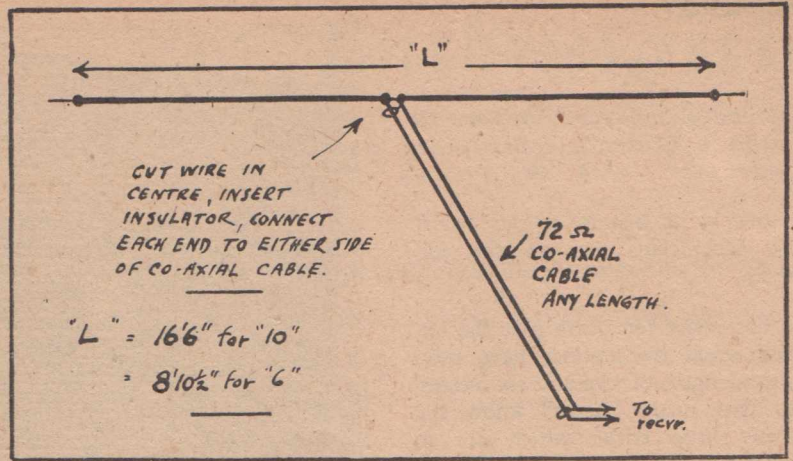

Design for aerial recommended for use on ultra high frequencies.

tional superhet. Sometimes the output of the converter is arranged at a frequency chosen by Kingsley for their 6-metre converter.

It is simply a matter of putting the Kingsley six-metre converter in front of any short-wave or dual-wave set which has reasonable sensitivity at 10.7 megacycles (just below the 31 metre overseas short-wave broadcast band) and you have what amounts to a double i.f.

superhet of the highest efficiency.

THE CIRCUIT

As will be seen from the circuit diagram, the Kingsley converter for six-metres consists of a carefully designed aerial matching circuit similar to that used in the KS9'er described in last months issue. The signal is then fed to the grid of an r.f. amplifier using one of the spec-

(Continued on page 28)

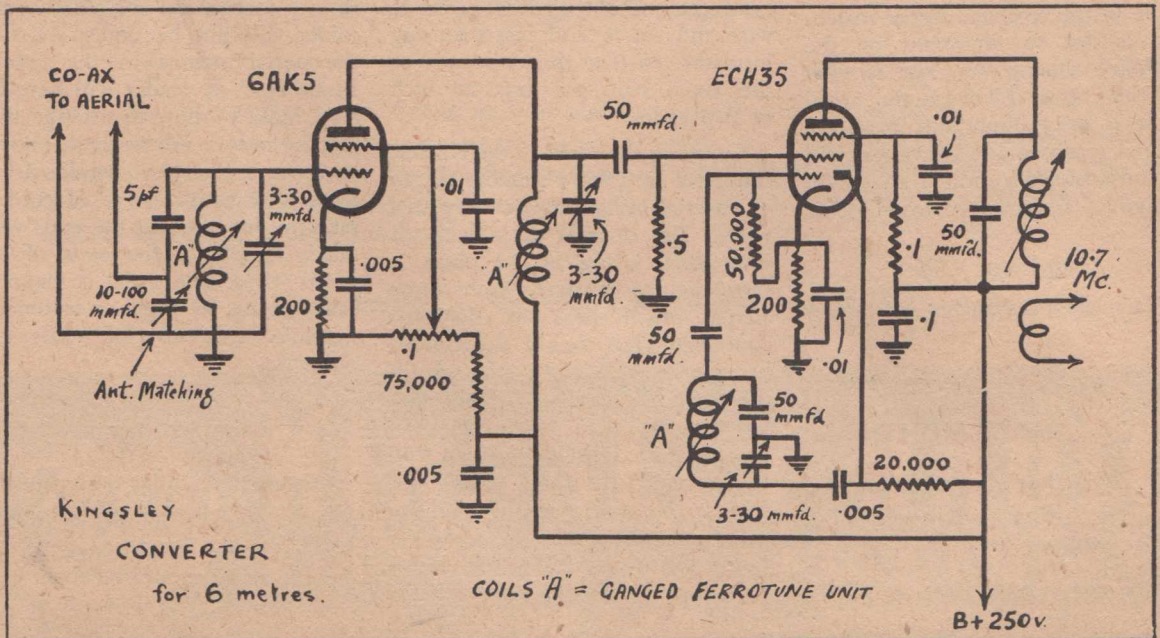

AEGIS



RURAL 4'

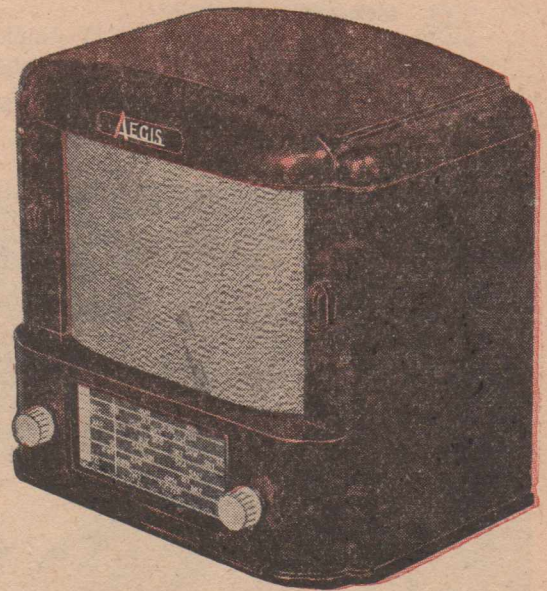
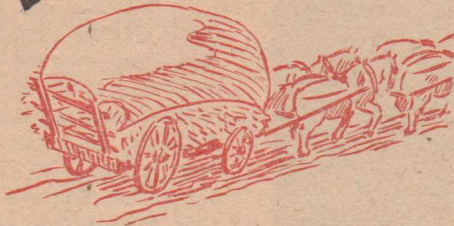

Introduction:

Prevailing conditions in the radio trade make the kit-set a splendid proposition for those who want to build their own radio set. Buying component parts bit by bit is a tiresome process, for few shops can supply everything you need. Some will offer substitutions which will not prove suitable. The kit-set is a complete collection of every item you need for the assembly of a receiver, including the cabinet. Every part is specially selected, matched to the other components and in every way suitable to ensure proper results from the finished receiver. The circuits for kit-sets are thoroughly tested, and months of development work is the background which guarantees that the performance of the set will be equal to the best obtainable from factory-assembled receivers.

You can't use up scrap parts from your junk-box when you build from a kit-set, but you are certain of complete satisfaction. Even to the person who has had no previous experience with radio set construction, the kit-set offers no problem; just a few hours of pleasant and interesting work and you find that you have not only a fine receiver, but also a wealth of technical knowledge. You don't need any knowledge of circuits to start. Comparing the picture diagram with the schematic circuit and the photographs of the original receiver provides interesting mental exercise and is by far the most effective and practical way of gaining technical knowledge.

—A. G. HULL

RURAL 4

Outstanding Features:-

★

Detailed by
The Engineering Staff
 Aegis Manufacturing Co. Pty. Ltd.
 208 Little Lonsdale Street
 Melbourne

★

- (1) High sensitivity with low noise level gives greatest effective daylight range. Ample selectivity for modern reception conditions. High-efficiency Rola permagnetic speaker ensures good tone and powerful volume.
- (2) Operates from dry batteries with very low current drain. Operating about four hours per day the set should run for longer than twelve months without any attention at all. No accumulator or battery charging.
- (3) Circuit has been thoroughly engineered and tested. Sample receivers built from actual kits have been air-tested in several States and give completely satisfactory performance.
- (4) Ample stocks of kits available from distributors throughout the Commonwealth. Every item supplied in kit, even to the smallest screw, nut and washer. Every component of the highest quality.

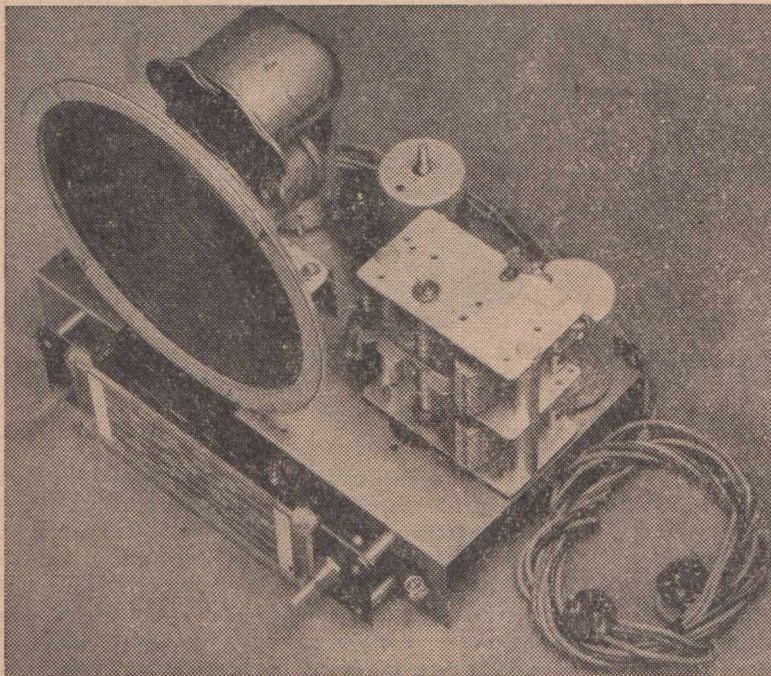

A photograph of the chassis, showing the Rola speaker, with the gang condenser alongside, and the coiled-up battery cable.

THROUGHOUT the history of radio developments there has been a close connection between the valve manufacturers and the circuit designers. For many years past the performance of receivers has largely been governed by the characteristics of the valves available. As improved valves have been released, so the performance of sets has improved. And so it is with this battery circuit, the first real post-war model which we have described for home use.

Key to the performance of this latest receiver is the use of the miniature valves which were introduced mainly for use in small portables. Their outstanding performance, however, makes them ideally suited for use in domestic receivers. They give high gain with low noise level and are so economical that it becomes possible to operate them entirely from dry batteries, doing away with the accumulator and its messy re-charging. How often does the accumulator run down just when there is something special you want to hear? Well, never again. This set will run about four

(Continued on next page)

hours a day for at least a year without any attention at all.

Some months ago the Aegis Company produced a kit for a battery-operated portable receiver called the "Voyager." As soon as this receiver was tested the excellence of the all-round performance was apparent, and it was obvious that with an outside aerial in place of the loop of the portable even better distance could be expected. Tests conducted along these lines showed the accuracy of this forecast and steps were taken immediately to get a kit-set into production. Scarcity of vital parts held up the release of the kit for a few months, but good use of this period of waiting has been made by getting sample receivers out to various interstate distributors for testing under local conditions. All reports indicate that we can have the utmost confidence in recommending this job as thoroughly tested and completely dependable.

ASSEMBLY

First of all, assemble the dial according to the diagram provided. This may require a bit of concentrated study, but if the diagram is followed closely, little trouble should be encountered. Having

- 1—Cabinet, bakelite, inc. grille and baffle.**
1—Chassis and speaker bracket.
1—Dial assembly complete with glass.
1—Dial drum, 3" (Aegis).
2—"Aegis" I.F. transformers, type "J-10."
1—"Aegis" Aerial Coil, type "M-9-L."
1—"Aegis" Oscillator Coil, type "M-18-A."
1—"A.W.A." 2-gang condenser.
1—"Rolo" speaker complete with 8000-ohm transformer, type 6H.
1—1R5 valve.
1—1T4 "
1—1S5 "
1—3S4 "
4—Button valve sockets.
2—M.E.C. trimmers.
1—Red terminal.
1—Black terminal.
1—Large "A" battery, 1.4 volts.
2—Large "B" batteries, 45 volts.
2—Knobs (Aegis).
1— $\frac{1}{2}$ " Rubber gromet.
30ft. 5-wire battery cable.
5ft. Hook-up wire.

THE AEGIS "RURAL FOUR"

Parts List

- 1ft. 20G tinned copper wire.**
3in. Resistor strip, $\frac{1}{2}$ " (Aegis).
- SCREWS**
8— $\frac{1}{4}$ " x $\frac{3}{32}$ " R.H.
3— $\frac{1}{4}$ " x $\frac{1}{8}$ " R.H.
3— $\frac{3}{8}$ " x $\frac{1}{8}$ " R.H.
4— $\frac{3}{8}$ " x $\frac{1}{8}$ " C.H.
2— $\frac{3}{8}$ " x $\frac{5}{32}$ " R.H.
2— $\frac{3}{8}$ " x $\frac{5}{32}$ " R.H.
1— $\frac{1}{4}$ " x $\frac{1}{8}$ " R.H.
8— $\frac{3}{32}$ " Hex. Nuts.
3— $\frac{1}{8}$ " Hex. Nuts.
9— $\frac{5}{32}$ " Hex. Nuts.
1— $\frac{3}{8}$ " Shk. Proof Washer.
2—Bolts, orn. head, $\frac{5}{32}$ ".
- CONDENSERS**
1—100 MMF. Mica.
2—250 MMF. Mica.
1—450 MMF. Mica.
2—.002 MFD. Paper.
1—.01 MFD. Paper.
1—.05 MFD. Paper.
2—.01 MFD. Paper.
1—25 MFD. - 40V. Elytc.

CARBON RESISTORS

| VALUE | WATTAGE |
|---------------|---------|
| 1—500 ohm | 1 Watt |
| 1—.1 Meg. ohm | 1 Watt |
| 2—1 Meg. ohm | " |
| 1—2 Meg. ohm | " |
| 1—3 Meg. ohm | " |
| 1—10 Meg. ohm | " |

| COLOUR | CODE | (Dot) |
|--------|-------|--------|
| (Body) | (End) | (Dot) |
| Green | Black | Brown |
| Brown | Black | Yellow |
| Brown | Black | Green |
| Red | Black | Green |
| Orange | Black | Green |
| Brown | Black | Blue |

1—1 Meg. ohm Volume Control with D.P.S.T. Switch W.S.T.

done this, tubular brass spacers are now supplied to facilitate mounting the dial plate on the chassis. Next, mount the button-valve sockets underneath the chassis, using the $\frac{3}{32}$ " screws and nuts. Follow the wiring diagram closely, making

sure their position is correct. Should there be any excess length of screw beyond the nut, nip it off with your cutting pliers, otherwise it may cause a short circuit on one or more of the valve socket terminals. We

(Continued on page 5)

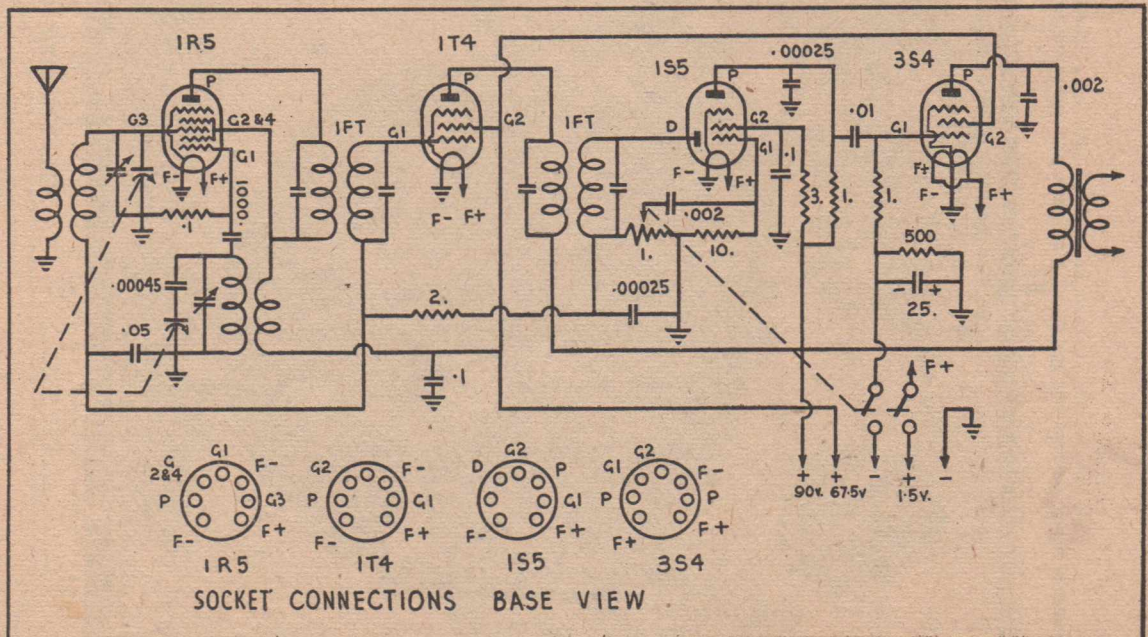

The schematic circuit, showing how closely it follows the "Voyager", highly successful portable described a few months ago.

PHOTOGRAPH OF THE WIRING OF THE ORIGINAL SET

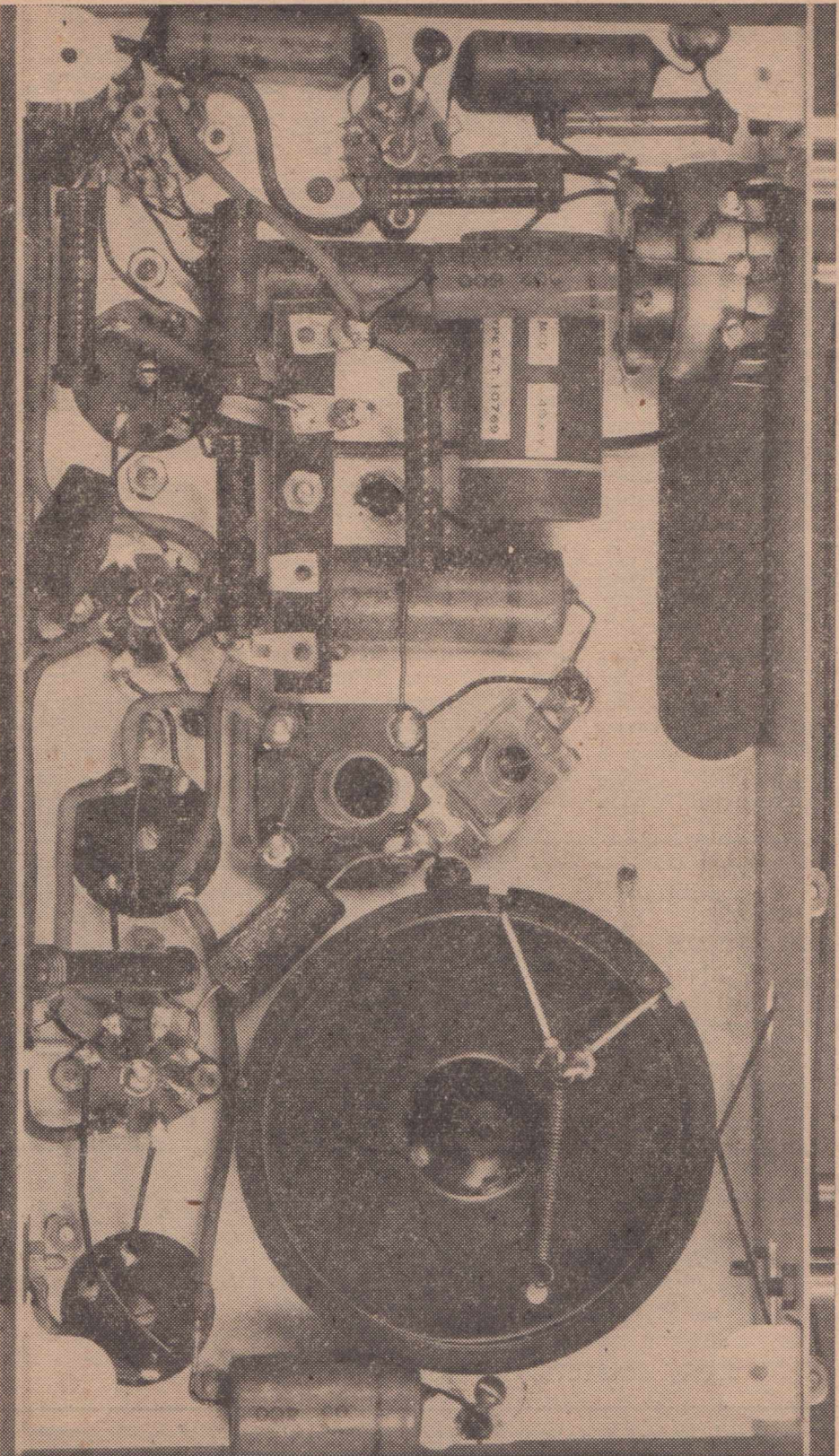

Almost full-size, this photograph of the wiring of the original receiver should be followed carefully and used as a guide for the placing of the components and the lay-out of the wiring.

(Continued)

have noticed a slight discrepancy in the manufacture of these sockets; the double space between pins 1 and 7 may lie either to the right or left of the nearest mounting hole, but this need not cause alarm. Now you are ready to mount the tuning condenser as shown in the pictures and diagrams, using three 3/8" x 1/8" square or round head screws. Be sure to place a 5/32" nut over each screw as it comes through the chassis and into the condenser. These three nuts act as spacers and results in a more stable mounting. Again refer to the pictures and wiring diagram as you mount all the coils. Be certain the numbered pins are positioned exactly as shown. On the oscillator coil, a coloured paint dot will act as guide to position. Mount the resistor strip, using one 1" x 1/8" screw and three 1/8" nuts. The speaker bracket can go on now using two 1/4" x 1/8" screws.

(Continued on page 20)

OTHER "AEGIS" KITS

Saving you lots of time and worry the Aegis kits are a sure way to successful radio set building. Every kit contains full instructions and is complete in every detail. Described in the May, 1946, issue was the "Metropolis 4," an all-electric mantel model in bakelite mantel model cabinet similar to the one used for the Rural 4 in this issue. This little set still stands as a thoroughly reliable kit with excellent all-round performance and a splendid proposition in every way.

Detailed in the June, 1947, issue was the "Voyager," a self-contained battery-operated portable of compact dimensions, yet fitted with full-size components and using batteries large enough to ensure long periods of service.

Both of the above sets are available in complete kit-set form, with cabinet and every item securely boxed and sealed.

FOUNDATION KITS

The Aegis Manufacturing Company also offers the "Connoisseur" range of foundation kits, consisting of steel chassis, coils, intermediate transformers, gang condenser and dial. These are available for a five-valve model, described in the September, 1946, issue and six and seven-valve models described in the February, 1947, issue. All are for a.c. operation.

Copies of the above back numbers of Australian Radio World are available at 1/- each, post free, by writing to Box 13, Mornington, Victoria.

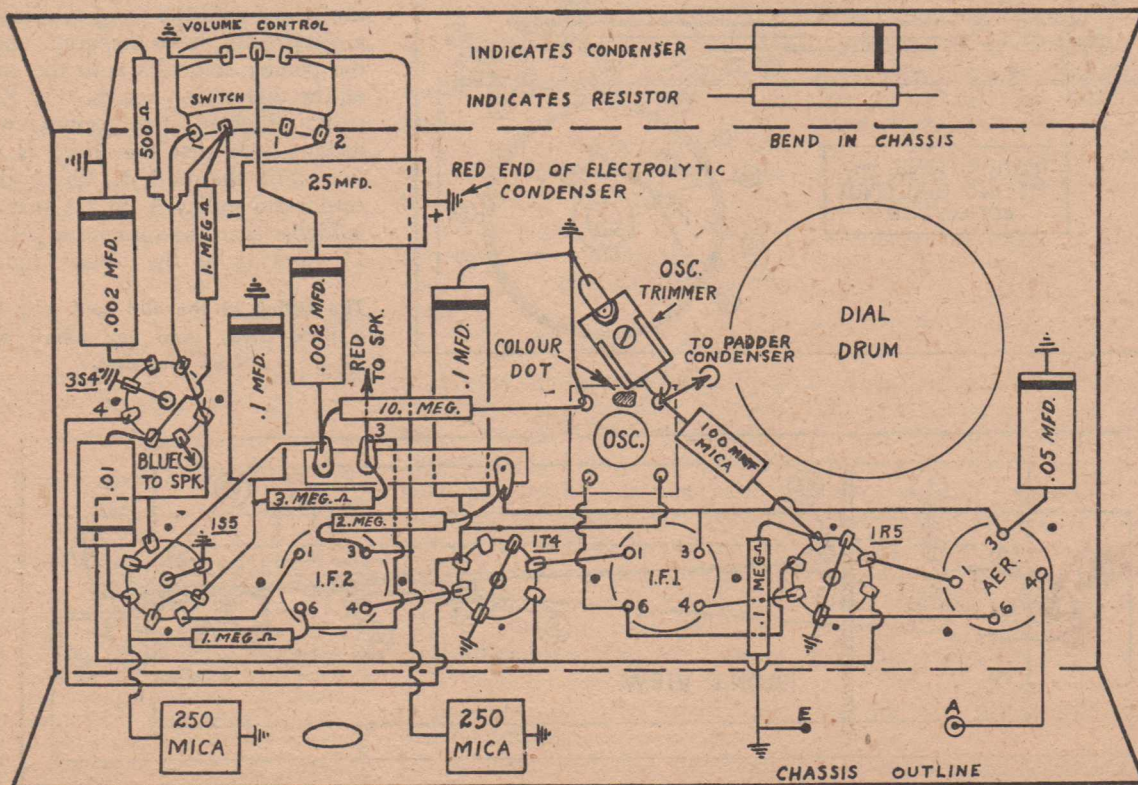

Use this picture diagram of the wiring in conjunction with the photograph opposite and you can't go wrong.

(Continued)

You will find that the holes for these screws are tapped in the chassis and nuts are unnecessary. The volume control mounts next and a 3/8" shake proof washer is placed over the threaded portion of the shaft first, before inserting it through the hole in the chassis and tightening the nut. With a 1/4" x 1/8" screw mount the aerial trimmer as shown on top of the tuning condenser. Next, slip the dial drum on the condenser shaft beneath the chassis, and follow up by mounting the aerial and earth terminals. Make certain the aerial terminal screw does not touch the chassis. The speaker and baffle board are left off until the radio is completely wired.

INSTRUCTIONS FOR FITTING THE DIAL CORD

Start with the pointer carriage and thread the dial cord through Hole 1, and out through Hole 9,

so that 24 inches of cord is left free from both Holes. With the gang condenser at maximum capacity, adjust the dial drum so that the cord slots are in the position shown. Pass the cord around pulley 2, then pulley 3, through the hole in the chassis 4, around the drum 5, through the slot 6, through the tension spring 7, and without tying any knots on the spring, attach the cord to a screw in the centre of drum 8, temporarily. Taking the rest of the cord, attached to the pointer carriage 9, put two turns around the tuning spindle 10, making sure to start from the front and top of the spindle. Then pass the cord around pulley 11, through the hole in the chassis 12, around the drum 13, through the slot 14, and pass through the tension spring 7, from the opposite side to the first cord. Free the first cord and holding one cord in each hand, tie a single overhand knot, as though tying a bootlace. Then by pulling with both cords,

GOOD AERIAL DESIRABLE

The use of an efficient aerial and a good earth connection is highly desirable with battery-operated receivers of all types. For an aerial use one at least fifty feet long, as high as possible, well clear of roofs, spouting and downpipes, and with a direct lead-in to the set. For an earth connection clamp to a water pipe which goes underground, or to a piece of piping driven at least three feet into the ground in a damp spot outside the house.

the tension can be increased until it is satisfactory, and the knot pulled tight at the same time. This knot will hold sufficiently to check the operation of the tuning mechanism and when it proves satisfactory a couple of extra knots can be tied and the surplus cut off.

SETTING THE DIAL

After attaching the dial glass loosen the grub-screws in the dial drum and with the gang condenser at maximum, move the drum until the pointer coincides with the end of the dial scale—not the 550 KC mark. Tighten the grub-screws, making sure that the drum is in line with the pulleys. Check the cord from pulley 3, to see that it is higher than the cord from pulley 11, looking at the chassis right-

The fitting of the dial cord may be a little tricky until you follow out these diagrams.

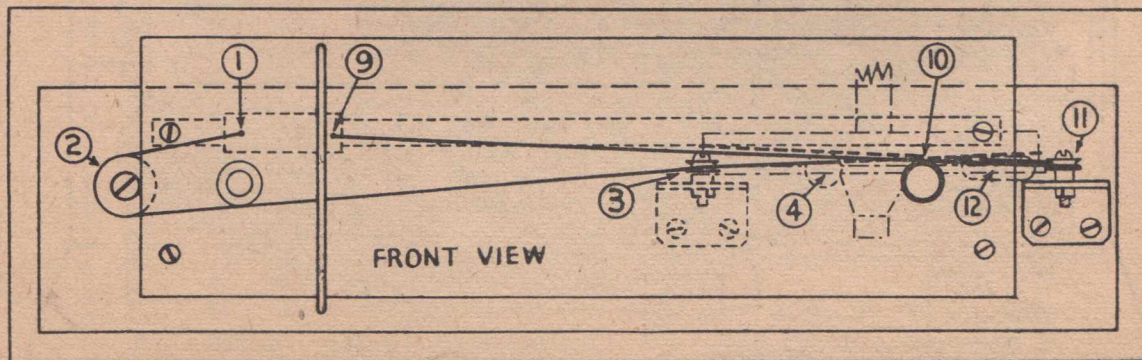
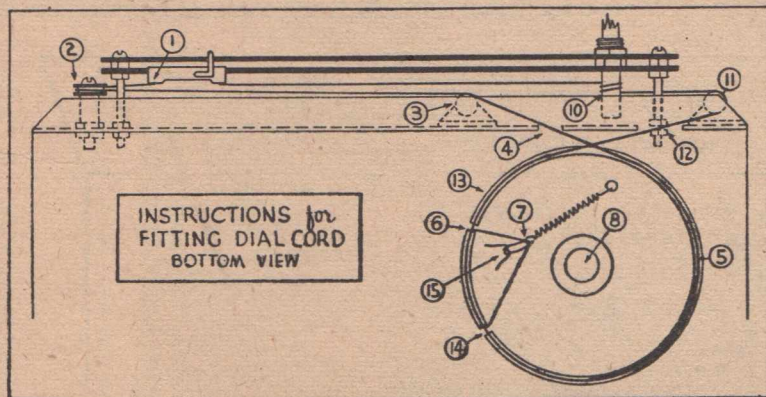

way up. If necessary, pack pulley 3, up slightly so that the cords do not rub together.

A drop of thin oil on the pulleys, slide and tuning spindle will improve the operation of the tuning mechanism, but make sure that no oil gets on the tuning spindle where the cord runs around it.

CIRCUIT AND WIRING

The circuit is essentially the same as the "Voyager," the differences being the use of a standard aerial coil in place of the loop antenna and the use of the tap on the "B" batteries to supply the 67.5 volts required for the screens instead of using a dropping resistor. This enables the 8 MFD. electrolytic condensers to be dispensed with as the impedance of the large "B" batteries is very low at audio frequencies; the only electrolytic that is required being a 25 MFD. across the back-bias resistor.

FOLLOW DIAGRAMS

The wiring of this receiver is so simple that there is little that can be said to facilitate it. Follow the wiring diagrams closely and place the condensers and resistors exactly as shown. A resistor colour code is given in the parts list. Number 20G tinned copper wire is used for earthing the valve socket terminals and for short, direct connections as between coils and grid or plate terminals on sockets.

IMPORTANT

Earthing the centre pins of the sockets is very important as they are provided as shields to prevent feed-back between valve pins.

BATTERY CABLE

Having completed all the main wiring, make up the battery cable

BEWARE

Even the best of valves are speedily ruined if the filaments come in contact with high tension voltage from the "B" battery. Take the greatest care to make sure you do not suffer a sad accident of this kind!

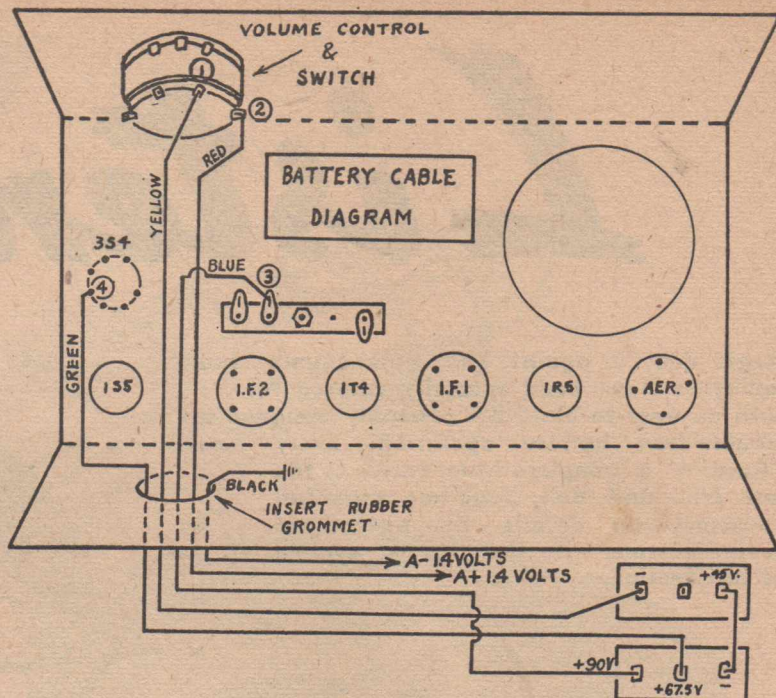

Incorrect connections to the battery can ruin the valves, so be careful to check connections with this diagram BEFORE you insert the valves.

from the six-foot lengths of different coloured rubber-covered wire. Twist or braid them together as you choose, then connect the various colours to points exactly as shown in the Battery Cable Diagram.

Now you are ready to mount and wire in the speaker and baffle board, using the four 5/32in. screws and nuts that are left; the two short screws mount the speaker and the two long ones mount the baffle.

FIRST TEST

Having finished the assembling and wiring it is desirable to check this, as battery valves are susceptible to being blown if the wrong volts get around. If you have a voltmeter, leave the valves out and connect in the batteries. Check the volts on the various points to see if they are correct. If you do not have a voltmeter, plug the valves in and connect the "A" battery only. Switch on and see if the filaments light up. After establishing that everything is in order the rest can be connected and the alignment carried out.

ALIGNMENT

A test oscillator, such as the one described in last month's issue is a great help to ensure perfect alignment, but don't be discouraged if you do not have an oscillator on hand. Excellent results can be obtained after alignment on the broadcasting stations if you do the job carefully.

With a test oscillator, align the I.F.T.'s to 455 kC. or if you do not have an oscillator, align the I.F.T.'s for maximum output on a station.

Then with the oscillator on 600 kC. or a station as near as possible to 600 kC., adjust the receiver oscillator iron core to bring it to its correct position on the dial.

Next, with a signal at 1400 kC. or a station as near as possible to it, adjust the oscillator trimmer to bring it to its correct position on the dial.

Repeat these two adjustments until both are correct, always making the final adjustment with the trimmer.

In aligning the aerial coil a test oscillator can be used with a

Listen to the

Aegis does it again! This time country radio hobbyists have been specially catered for . . . with an easy-to-build Kit assembly designed for trouble-free battery operation. Every Aegis "Rural 4" is complete from Valves to the last Nut and Bolt, together with full constructional details, all packed in sealed cartons with the "Aegis" symbol of satisfaction.

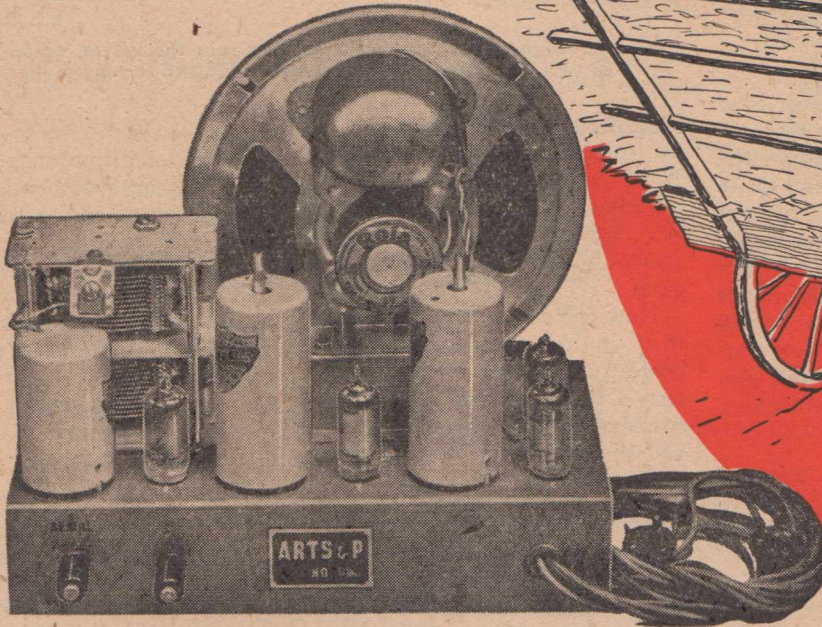

FEATURES OF THE RURAL FOUR

- Attractive Mottled Bakelite Cabinet.
- Button Valves for low drain with maximum gain—1S4, 1R5, 1T4, 3S4.

VICTORIA:
Replacement Parts Pty. Ltd.
J. H. Magrath & Co.
Lawrence & Hansen Elec. Pty. Ltd.
John Martin Radio and Elec. Pty. Ltd.

N.S.W.:
Geo. Brown Pty. Ltd.
John Martin Pty. Ltd.
W.A.:
Nicholsons Ltd.
Atkins (W.A.) Ltd.

(Price slight
variable Interstat
ATTRAC
A E
MANUFACTUR
A

This!

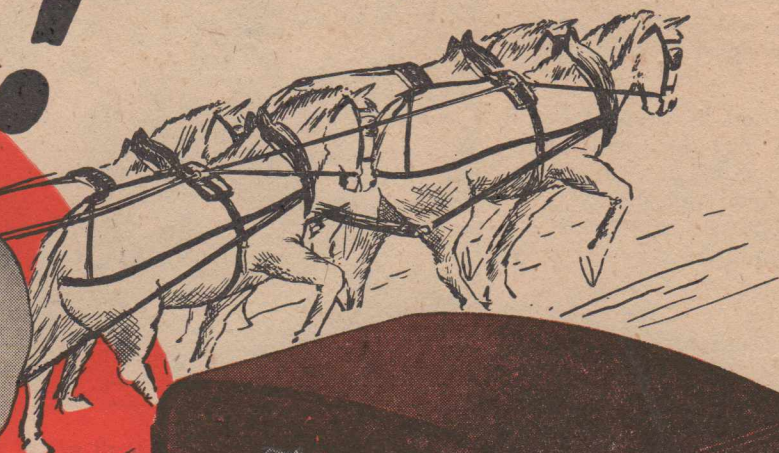
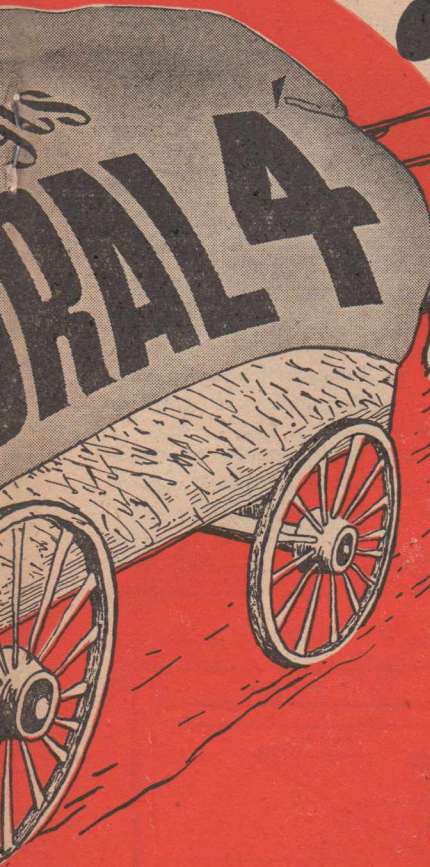

Lightly (rate) **£13/13/-** PLUS VALVES AND BATTERIES
ACTIVE DISCOUNT TO AMATEURS AND TRADE

AEGIS

TRADING COMPANY
PTY. LTD.
208 LIT. LONSDALE STREET
MELBOURNE

- "Aegis" Iron Core I.F.'s J9 and J10 specially designed for optimum gain.
- "Rola" 6-in. Permag Anisotropic Speaker with Isocore Transformer—highly important for Battery Sets.
- Chassis and all metal brackets cadmium-plated.
- W.S.T. Switch Potentiometer.

S.A.:
Healings Ltd.
Harris Scarfe Ltd.
Newton, McLaren Ltd.
QUEENSLAND:
Chandlers Pty. Ltd.

TASMANIA:
Lawrence and Hansen Elect. Pty. Ltd.
Hobart and Launceston

RURAL 4

(Continued)

dummy antenna, but we would suggest that final alignment be made using the aerial that will be used on the receiver, using weak stations near 600 kC. and 1400 kC. or a weak radiated signal from the test oscillator.

The aerial core is adjusted for maximum at 600 kC. and the aerial trimmer is adjusted at 1400 kC. These two adjustments are repeated until both are correct, making the last adjustment with the trimmer.

BATTERY LIFE

The receiver is now ready for operation and we feel that the performance that will be obtained from it will be exceptional. Reception of all States of Australia from Melbourne is an accomplished fact and battery drain (12-14 Milliampères) is such that at the rate of four hours' use per day, more than twelve months' service can be expected from the batteries

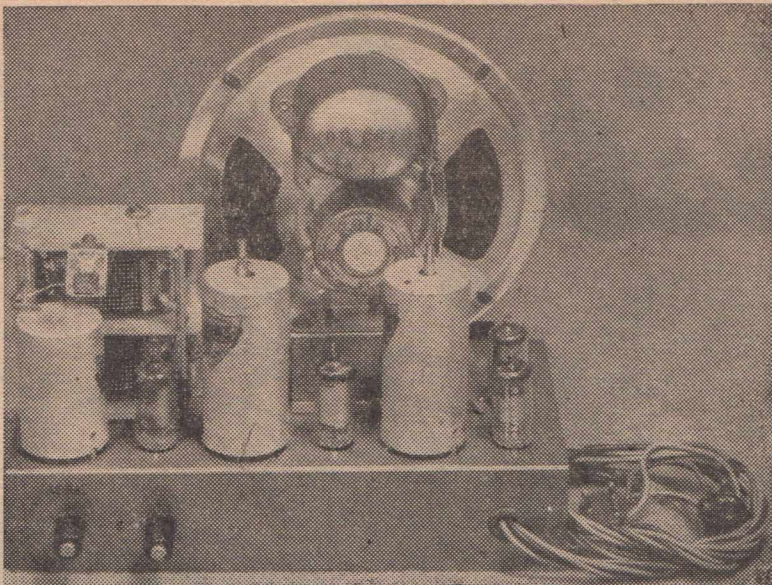

Rear view of chassis. Note the small size of the highly-efficient miniature valves.

without the necessity of charging worries.

We feel confident that you will be proud of your "Rural Four," having built it yourself, and with a good aerial and earth, shall en-

joy many happy hours of entertainment at a minimum of cost.

CONCLUSION

We welcome, at all times, your inquiries and constructive criticism.

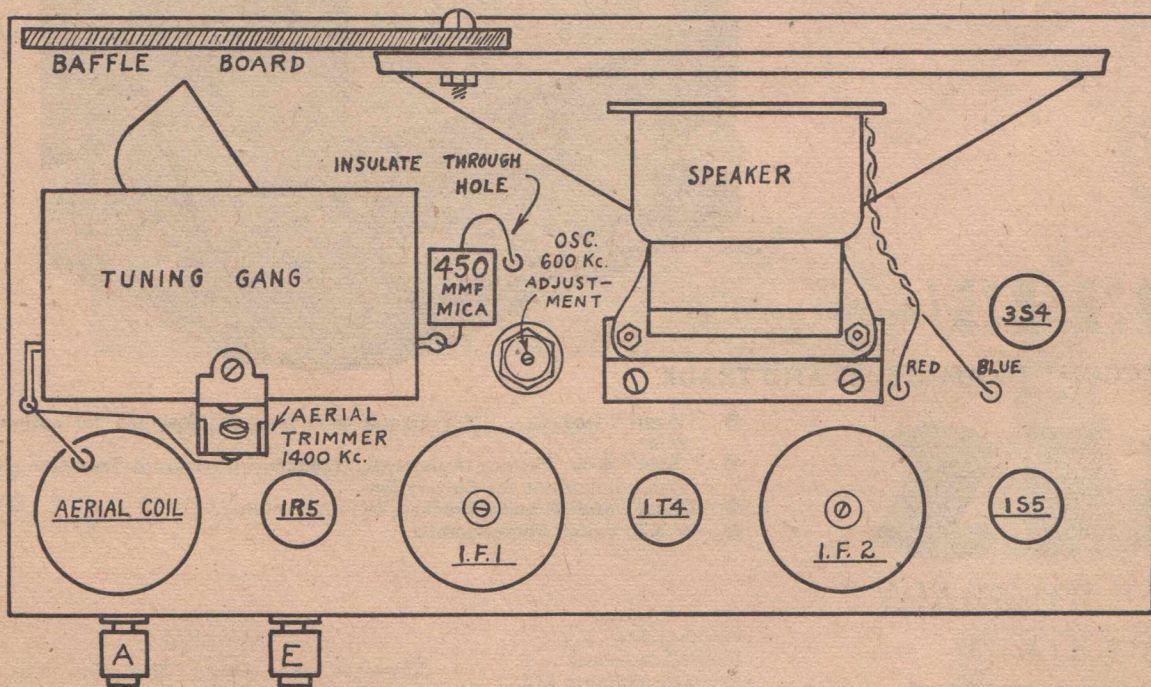

Plan of lay-out, showing positions of components and location of aerial trimmer adjustment.

The "Voyager"

THE design of the "Rural 4" is based on the circuit of the "Voyager" self-contained battery-operated portable receiver which was described in the June issue of Australasian Radio World. Not to be confused with the baby "personal" portables, the "Voyager" is not built to the smallest possible dimensions and uses many full-size standard components and batteries heavy enough to ensure long periods of use without replacement. A loop aerial is used, so that no external aerial or earth connections are required. The set is always ready for use by simply turning the volume control which is connected with the switch.

Copies of the June 1947 issue in which this set was described, are available at 1/- post free by writing to Australasian Radio World, Box 13, Mornington, Victoria.

The Voyager Portable. Below, the circuit diagram of the Voyager, which is in many respects similar to the Rural 4.

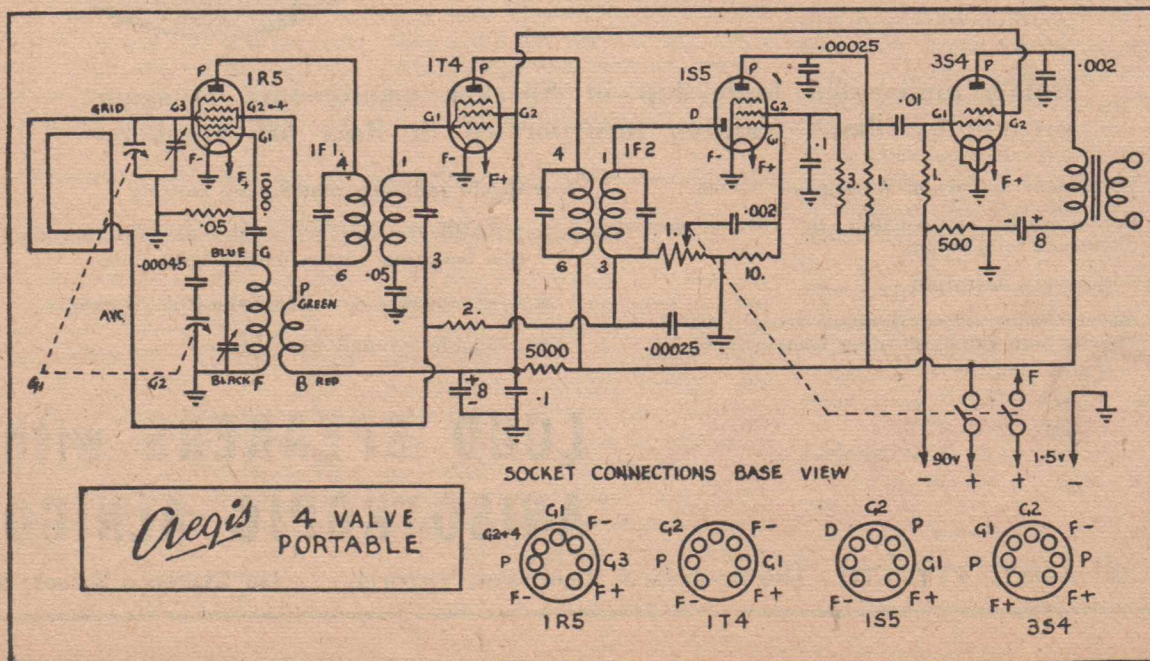
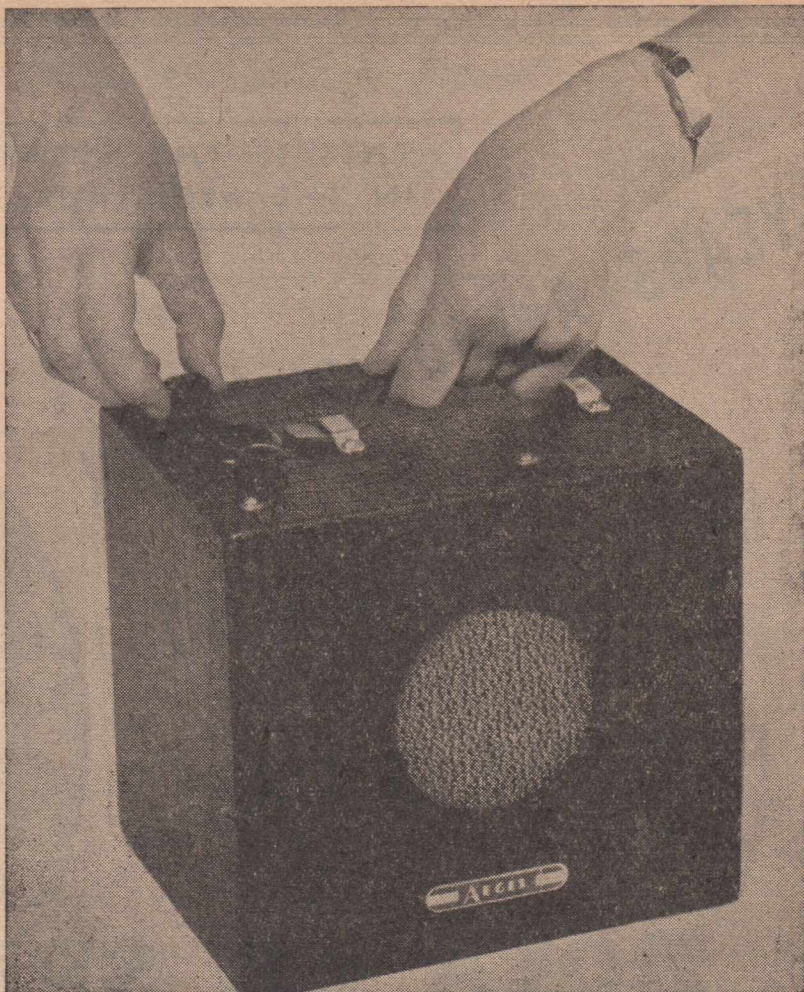

THIS IS THE SPEAKER
IN THE AEGIS RURAL 4

YEARS AHEAD IN DESIGN

HIGHEST IN QUALITY

FOREMOST IN VALUE

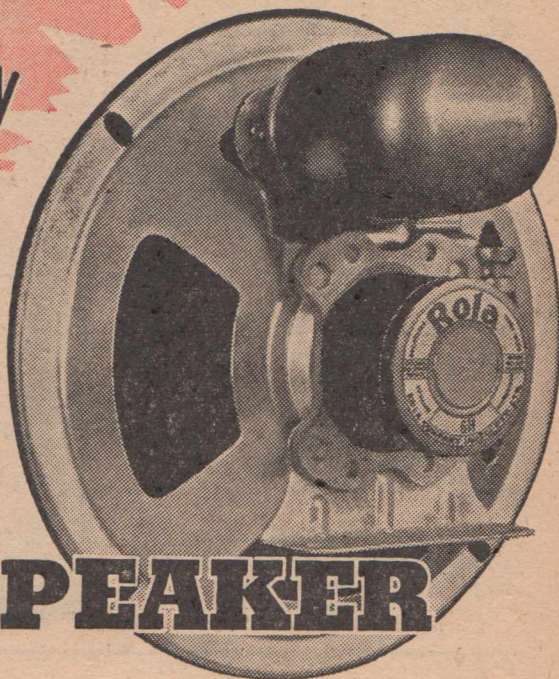

ROLA 6H SPEAKER

Rola's undisputed leadership in Speaker manufacture is again proven by these features incorporated in Rola 6H Speakers.

- ★ Permanent magnet of Anisotropic Alnico.
- ★ Bright cadmium plated cone housing.
- ★ Permacentric construction to ensure perfect diaphragm alignment.
- ★ Scientifically designed to give pleasing reproduction from sets with a limited baffle area.
- ★ Completely dustproof.
- ★ Every speaker covered by the Rola Warranty.
- ★ Isocore transformer immune from electrolysis, the common enemy of other transformers.
- ★ Available through trade houses.

ROLA

LOUD SPEAKERS with ANISOTROPIC ALNICO

ROLA CO. (AUST.) PTY. LTD., The Boulevard, Richmond, Victoria.

116 Clarence Street, Sydney

Adjusting the Inductive Dipole

Some hints from H. K. Love (VK3KV)

There's little new under the sun, and many radio applications of present-day practice can be found, basically, in embryo form at least, two decades or more back. Thus it is with the "Inductively-coupled" Dipole antenna, the principle of which can be seen in the early time "Pickard" . . . once a very popular idea with 56 mC. experimenters, and in the 1934 era . . . in the "Noise reducing transformer-coupled doublet antenna" as described in "Radio," U.S.A., by W9SU. The latter was essentially for receiving purposes, and used two transformers one at the centre of the antenna, and the other at the receiver—on twisted pair line. Each transformer had a static shield between antenna inductance and link coil, and my recollection of this antenna was that it turned out to be the most effective of all the noise-reducing systems. The idea might well be applied to transmission in modified form, as the Faraday type shield should be effective in providing a purely resistive load to the transmitter, which is just what is wanted.

Many VK's are finding the W9NLP scheme as described in "Q.S.T." recently very sure-fire and effective, and even without parasitic elements, it is quite a handy application for both transmission and

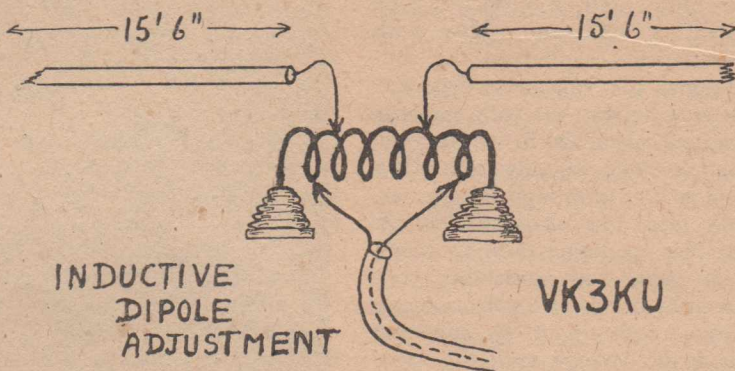

reception. Howard Love (VK3KV) is using a modified type in his multi-beam array for 14 mC. Of this he says: "Several fellows down here got them up on advance information from W9NLP, but the 8 turns 2-inch diameter plus 15 feet 6 inches for elements *just can't be right*. 35 feet is not the resonant length for the band, and 8 turns 2-inches in diameter is 4 feet in anybody's arithmetic. VK3EN got one up and found that he had to couple very tightly to make it draw. I suggested that he cut the 8 turns in the element to 4 turns and use 2 turns of coupling—the element is then just 33 feet long. This was done and it goes well. In my case, I took the view that there are two adjustments necessary: (a) the electrical length of the dipole for reson-

ance; and (b) the impedance match of the feed cable; so I made an 8 turn coil and provided *four* clips for adjustment of element length and feedline coupling respectively. Procedure was, first with 2 turns loosely around the coil and connected to the line, with R.F. on, the element clips are adjusted for maximum draw, i.e., the electrical length is thus established. Next, the coupling clips are adjusted until the load is completely "resistive," i.e., impedance is matched. This worked out in my case with 4 turns included between the element taps. As I use 120 ohm, twi-coaxial line the position was found on the line taps with 6 turns between. A 600 ohm line would doubtless use 8 turns, or possibly 10. Total result is that the element draws maximum current from the tank and the line is matched into the system at the right point. It will be obvious that 72 ohm or 50 ohm line will be somewhere about 2 or 3 turns, but this is a very accurate means of adjustment at the aerial end. All adjustments were made with the reflector and director in position so there is no further change in impedance by the presence of parasitic elements. All taps are then soldered firmly to the coil—this information may be of value to the gang."

Thanks, Howard, it is; and is hereby passed on accordingly.

—D.B.K.

OLD HANDS — NEW GEAR

On an August evening in Sydney, a number of old-timers foregathered at the home of Chas MacLurcan, VK2CM. Among them were VK's 3KU and 2NO. There was also present a sizeable collection of modern receiving equipment from 3KU's Melbourne factory. Included was the KCR/12, something unique in the way of Ferrotuned Amateur Band receivers, and having outstanding electrical and mechanical features;

a 50 mC/s Converter . . . also designed around iron-cored tuning units; and a "KS 9'er." There was also a neat midget "personal" B/C receiver, the "Walkie Talkie." All these things work as nicely as they look, and speak well for the ideas and efforts of the engineers concerned. Anyway, would one expect other than excellent Amateur gear from an Organisation's factory, when the M.D. is a very active 100 per cent. Ham himself?

(Continued)

ial types of valves designed for the ultra high frequencies, type 6AK5, a miniature valve with characteristics similar to the conventional 6.3 volt heater-type a.c. operated valves, but with specially designed elements to ensure low inter-electrode capacity and allow good gain at ultra high frequencies. Both grid and plate of this r.f. amplifier are tuned to allow maximum gain, with instability controlled by means of a potentiometer in the screen circuit. By adjusting this screen voltage until the valve is just on the verge of "spilling over" it is possible to get terrific gain with low noise level. From this r.f. amplifier the signal is fed to the grid of one of the latest Philips converter valves, the ECH 35. Plate circuit of the ECH35 is tuned to 10.7 megacycles, with a coupling coil to match the aerial primary of the receiver to which the converter is attached.

FERROTUNING

A most interesting feature of the converter is that the tuning is accomplished by iron slugs moving in and out of the coils. Referring again to the circuit diagram it will be noticed that we have indicated these three coils with the letter "A". They are all tuned by slugs, ganged together and operated from the main tuning control. They can be seen clearly in the photograph of the inside of the converter. This form of tuning gives a splendid "band-spread" effect, so that the whole sweep of the tuning dial is needed to cover from 50 to 54 megacycles, the full width of this ham band. As a result, the tuning is no more difficult than that of an ordinary broadcast receiver.

Power supply for the converter is taken from the receiver to which it is attached, three wires being provided, one the high tension lead,

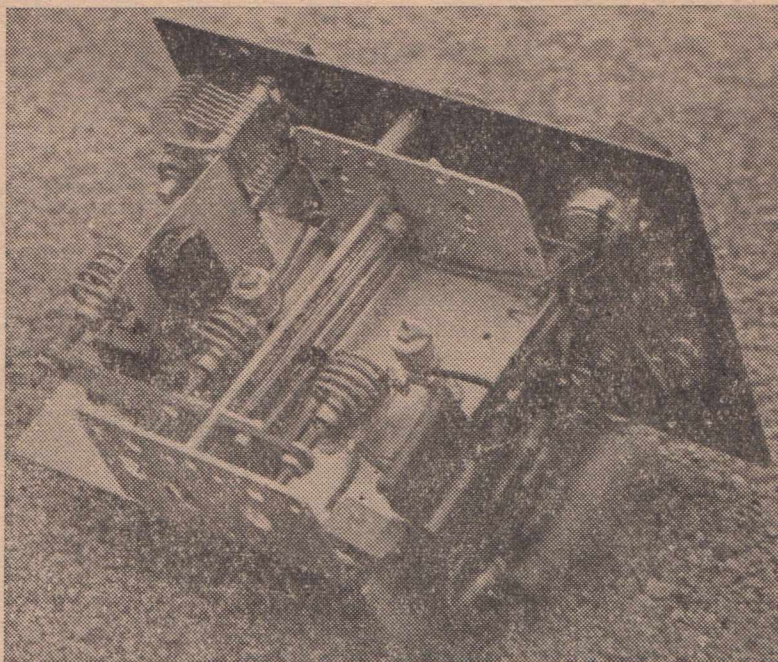

A photograph of the inside of the Kingsley converter showing the coils and their tuning slugs.

the other for the 6 volts a.c. and the third is a common return lead for high tension, heater current and earthing. Only a few milliamps of high tension current is drawn by the converter and this can be taken from almost any set without upsetting its performance in any way.

MODEST PRICE

At the moment the Kingsley converter is available at a modest price as a completely built up and tested unit in a neat crackle-finish box. It means that all and sundry can now tune the six-metre ham band with ease if they have a receiver which will tune to 10.7 mcs. Later it is possible that the Kingsley converter will be made available in kit form.

Another Kingsley unit which will be hitting the market about the same time as this story appears in print is a somewhat similar con-

verter, but to cover the ten-metre ham band and the many overseas stations which romp in under favorable conditions on that band. On the six-metre band, in case we haven't mentioned it, the normal range is only 20 or 30 miles, with DX reception coming in on rare occasions. As you will surely know if you have read Don Knock's pages over the past year or two, the incidence of DX reception on six-metres is most interesting, elusive, in fact exciting. With larger numbers of efficient six-metre converters in the hands of enthusiastic listeners there is every possibility that signals from the American mainland will be heard in Australia. If and when this happens the lucky listener will enjoy considerable fame. To all enthusiastic listeners who enjoy the thrill of the chase after elusive DX we can recommend the Kingsley converter as an item which should be alongside the prided receiver.

SERVICING BY SIGNAL TRACER

How to use Equipment detailed In Last Month's Issue

THIS article is written as a follow up on the Signal Tracer recently described, in the hopes that it will assist those contemplating building and using such an instrument, and maybe convert one or two of the diehards who insist that a Tube testing Multimeter will solve all problems—I used to belong to that frater-

By

JACK WEATHERILL

VK7PW

**141 George Street
Launceston, Tasmania**

nity myself until I was introduced to the Signal Tracer.

If I may be allowed to digress for a moment regarding the Signal Tracer itself, slight instability was encountered in the finished model. This was completely cured by decoupling the two IF plate supplies with 2,000 ohm resistors and .1 uF condensers and inserting a 400 ohm resistor in series with both IF cathodes between the individual cathode resistors and RF gain control to give a minimum bias of about 4 volts.

There are a number of different ways in which this article could be written. I propose to take an average five valve circuit, as shown, run through it with the tracer from input to output to give an idea of what to expect, then treat each valve and its associated circuits in detail, in order that the reader may get an idea of what to expect at each test point. It will then be obvious that if results are not up to expectations, something must be wrong. A quick check with an ohm meter or substitution of compon-

ents will then locate the trouble as a rule.

Firstly connect the chassis or common earth of the tracer to a similar point on the set under test. This is a most important point as otherwise the tracer and VTVM will not function properly. Connect an aerial to the set or feed in a signal from a modulated oscillator. Then tune the tracer to this frequency—say 1,000 KC—either by placing the RF probe on the oscillator output or holding in the hand and tuning in the B/C station.

Place the point of the RF probe on (1). A weak signal should be heard. Proceed to joint (2) the mixer input grid. Quite a respectable signal should be heard at this point, peaking at 1,000 KC on the receiver dial and diminishing on either side as the tuning gang is moved.

Now tune the tracer to the IF frequency—say 455KC. Place the RF probe on point (3). This signal should be much louder than (2) due to the conversion gain of the mixer. It will probably be necessary to adjust both RF and Audio gains as you approach the output end of the receiver.

From (3) we go to (4) the IF input. There should be a slight drop in signal strength between these points due to IF transformer loss. The RF probe may slightly detune these circuits, but as the probe capacity should only be a couple of picofarads at most, the effect should be hardly noticeable.

From (4) to (5) there will be a large gain due to valve amplification, and from (5) to (6) similar results as (3) to (4).

We now change over to the Audio Probe. At this point the RF gain may be screwed back to keep

out stray QRM which may get in via the probe, although the pickup on the probe itself is very small.

Adjust the audio gain to a convenient setting and place the audio probe on (7). The audio component at this point should be roughly the same as the RF signal at (6). Then proceed to (8). The signal should be about the same intensity as at (7). At point (9) the moving arm of the audio pot, the signal strength should be variable from that at point (8) to no signal. At (10), the input to the first audio stage, the signal should be similar to that at (9).

From (10) to (11) there will be a large gain. Wise use of the tracer audio gain control will prolong the life of its speaker and also keep the neighbours happy. At (12) the signal will be similar to that at (11). From (12) to (13) there will be considerable gain due to the amplifying action of the output valve, and quite a fair signal at (14), though there may be some drop due to the transformer losses.

A PRACTICAL EXAMPLE

And now, having seen what happens to the signal let us go back again and do the thing with a little more detail.

Firstly adjust the tracer to 1,000 KC and the VTVM to 500 volts. Switch on the set under test. Place the voltmeter-probe on (26), the input to the HT filter. The voltage will probably go up to about 500 then drop to around 350. About 10 to 20 volts either side would be a permissible variation. Anything under 200 volts would indicate a poor rectifier, high leakage in first reservoir electrolytic or heavy drain on the other side of the filter inductance. Place the voltmeter probe

(Continued on next page)

SIGNAL TRACER

(Continued)

on (27). It should read about 250 volts. Abnormally low voltage at this point would indicate excessive current drain, due to faulty filter condenser or short somewhere on the HT line. High voltage would point to low current drain, due to "worn out" output tube, or shorted turns in Speaker FC.

Presuming that the HT is OK, wind on some RF and audio gain and place the RF probe on (1). A weak signal should be heard. No signal points to shorted antenna or maybe open primary. Proceed to point (2) and rotate the receiver tuning condenser about 1,000 KC. The signal indicates shorted condenser plates, or faulty valve. Lift the grid clip off the valve, and check the signal again. If the grid winding peaks with the grid clip off, but not with it on, the valve could be at fault even though it tests OK in the Valve Checker. If the grid peaks at 1,100 or 900 KC

the trimmer probably needs adjustment. Switch the voltmeter to 25 volts, range and check the AVC at (2). Anything up to 20 volts may be expected, depending on the input signal.

Tune the tracer to 455 KC or whatever the IF happens to be. A strong signal should be apparent at (3). Check the voltages—250 (3), 100 (18), 3, or thereabouts (25), and between 10 and 20 at (28), the oscillator grid. Rotate the gang from the HF to the IF end of the dial. The grid volts will be fairly constant dropping off a bit towards the LF end. No volts, or a slightly positive voltage at this point means no oscillation. Point (19) should show between 100 and 200 volts. A quick check with the voltmeter between points (19), (29) and (20) will localise any troubles around this point. Turn off the audio gain and place the RF probe on points (28) and (19). Switch the voltmeter to the 125V range and the voltmeter selector to read the tracer AVC. Tune

the tracer to the receiver oscillator frequency, i.e. Signal plus IF—say 1455 kC/s. A negative swing of the voltmeter needle at this point will indicate if the oscillator is working at the correct frequency. Place the RF probe on point (24), and tune the tracer to the IF frequency. A loud signal at this point will indicate an open circuit AVC filter condenser.

Proceeding to the IF amplifier stage, place the RF probe on (4). There should be a slight drop between (3) and (4). A very large drop would indicate incorrect tuning of the IF transformer or faulty transformer due to electrolysis or faulty trimmer. Electrolysis is usually accompanied by a frying noise in the receiver speaker. Place the probe on point (15). No signal or only a weak signal should result. A loud signal will indicate open cathode bypass. Check voltages as for previous stage. Place the RF probe on point (18) of the IF screen. A loud signal will indicate open or faulty screen bypass. At point (5) there is a con-

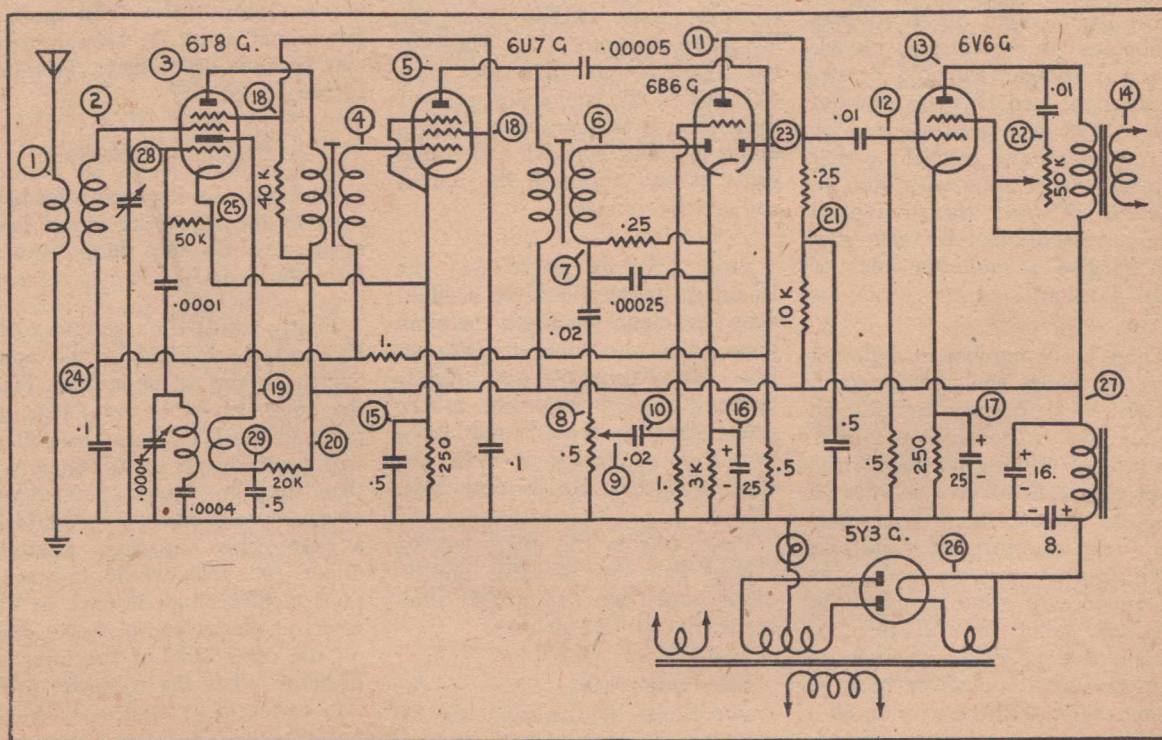

siderable increase in gain and at (6) a slight drop from (5). Check the signal at (23) the AVC diode, the signal strength will be as good as that at (6), possibly as loud as (5). Check the voltage at (23). It should vary up to about 20 volts, depending on the RF input to the set. The triode plate volts will read somewhere in the vicinity of 100 volts.

AUDIO TESTING

Now change over to the Audio Probe, and apply it to (7). An audio signal of about the same intensity as the IF signal at (6) should be heard. A signal at (6) and no signal at (7) could mean open circuit transformer secondary (the RF getting across by capacitive coupling), shorted diode load filter condenser or shorted diode load. Next place the probe on (8). The signal should be similar to (7). A large drop or fluctuating signal will indicate faulty coupling condenser, a far from uncommon fault. At (9) the signal should vary from zero to maximum as the receiver volume control is rotated. At (10) the signal should be similar to that at (9) if the coupling condenser is OK, and there are no shorts on the grid connection. Now place the probe on (16). There should be little or no signal. A large signal will indicate faulty 25 uF electrolytic. Check with the voltmeter to see if the bias is correct, one volt or so being average value.

Turn the gain back and go to (11). There should be a large increase in signal due to the amplifying action of the valve. Next place the probe on (21). The signal should be weak at this point, if any, and be devoid of high notes due to the bypass action of the .5 uF decoupling condenser. Check the voltage. It will probably be around the 200V mark.

Place the probe on (12). Signal will be similar to (11). A large drop will mean faulty coupling condenser, a fairly common fault. Set the voltmeter to 500V and place

the voltmeter probe on (12). Switch back towards the 5V range. Any reading in excess of half a volt means a leaky coupling condenser, since the output tube is using cathode bias. If back bias were being used, about 12 to 14 volts negative would show. Anything much less than this would indicate low HT current drain or leaking coupling condenser. Set the voltmeter to 25V, apply probe to 12 and turn receiver gain up. Any fluctuating negative voltage will indicate grid current. This may be due to insufficient bias (faulty output tube) or just plain overload. Check the cathode bias, about 12 to 14 volts for the 6V6. Apply the audio probe to (17). A load signal indicates faulty electrolytic bypass.

Now go to (13)—turn the gain back first. A large step up from (12) should be apparent. Next go to (22). The signal should vary

as the tone pot is rotated. Check the plate and screen volts, 230 volts plate about 250 screen depending on the resistance of the transformer primary. Lastly, check (14) the transformer voice coil winding. If you have a signal here and still no noise worth speaking of in the receiver speaker, the voice coil winding on the cone is probably open.

And that just about brings us to the conclusion of this discussion. There are probably some things I have omitted, and no doubt the reader will be able to think up other uses for the tracer. To those interested in a more detailed study of the subject, I would recommend that excellent text book by Rider. Anyway I hope you find the foregoing interesting and of help in using the versatile instrument previously described.

**SAVE MONEY
WITH A
SUBSCRIPTION**

Order Yours To-Day



Make sure you get every issue as soon as it is published. Place an order with your newsagent or send direct to us for a subscription.

**IT SAVES YOU MONEY!
IT SAVES YOU TIME!**

We guarantee that every subscriber has his copy posted the same day it comes off the press.

RATES

- ★ 6 issues 5/3
- ★ 12 issues 10/6
- ★ 24 issues 20/-

POST FREE

Enclosed please find remittance for 10/6 in payment for an annual subscription to the "Australasian Radio World," commencing with the..... issue.

NAME
STREET and NUMBER
CITY STATE

AUSTRALASIAN RADIO WORLD

Balcombe Street
Mornington



Calibration immediately pin-pointed

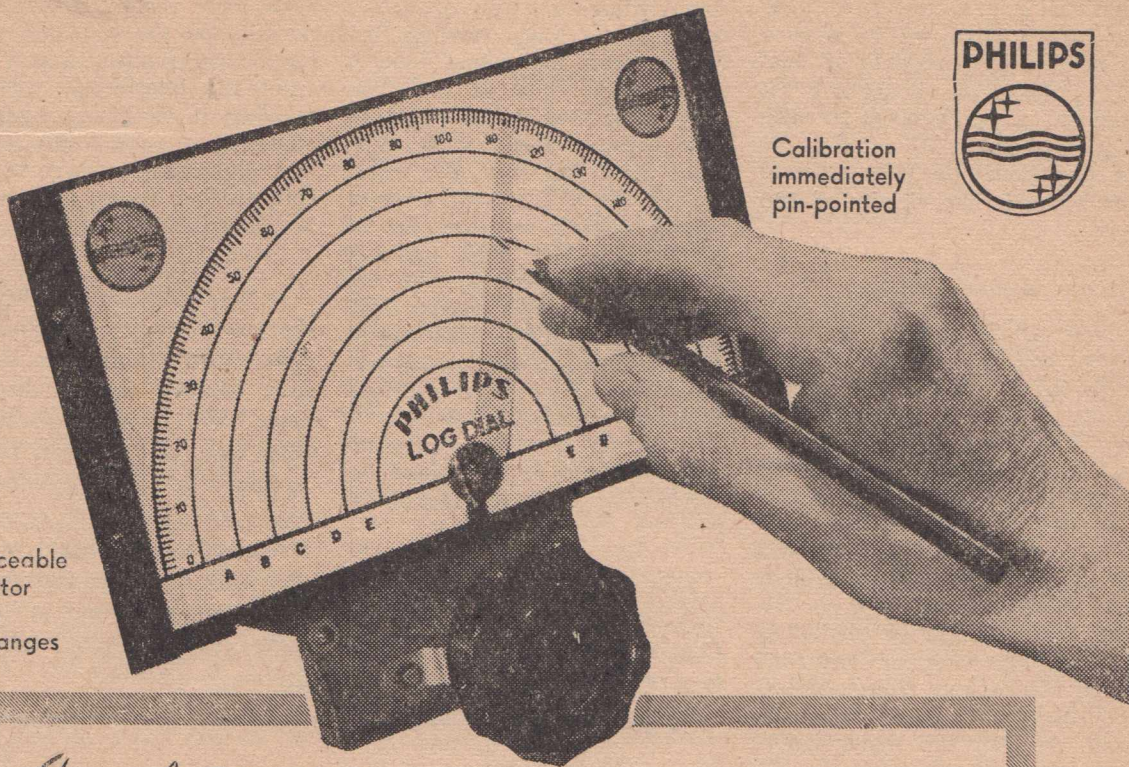

Replaceable Indicator Scale. Five ranges

Available NOW!

PHILIPS LOG DIAL

for easy, accurate, individual calibration

Specially designed for transmitting radio amateurs, short wave listeners and equipment engineers, the new Philips "Log-Dial" is the ideal control and indicator mechanism for VFO (Variable Frequency Oscillator) Transmitter application, Amateur Band HF Receiver bandsreading, VHF Receiver tuning, Frequency Meters, Monitors and for many other radio and electrical applications. The Philips "Log-Dial" mechanism provides positive, smooth running with no slip or backlash. It has an ample reduction ratio for

quick or slow tuning; calibration cannot be affected by mechanical troubles. The off-set Cursor provides instant logging without the need for scale reference or movement. The two colour scale is removable, two are included with each "Log-Dial", and replacements are available. It may be mounted on front of or behind instrument panel. The Philips "Log-Dial" is designed for $\frac{1}{4}$ inch shaft drive but is adaptable to larger sizes. It is finished in attractive Florentine Bronze.

25/-

● The "Log-Dial" is available now from your nearest Philips branch; the price is only 25/- with special reduction for licensed amateur radio transmitters.

Dimensions $8\frac{3}{4}'' \times 4\frac{7}{8}''$



PHILIPS ELECTRICAL INDUSTRIES OF AUSTRALIA PTY. LTD.

Sydney • Melbourne • Adelaide • Perth • Brisbane

CALLING CQ!

By Don Knock, VK2NO

ONE of the best Disposals "snaps" I have seen is that compact little A Mk 3 job. At around £13 it is a gift. In the space of a *small* attache case is contained a complete CW transmitter and receiver of no mean performance, with a frequency range of 3 to 9 mC/s, depending upon which crystals one applies. The TX has a Pierce oscillator driving a Tetrode PA, with RF output of the order of 4 watts to the antenna. The RX is an ingenious 3-valve superhet, reflexed and whatnot. No wonder Britain won her war with secret service people using such gadgets under the nose of Fritz and Co.

* * *

Verily OM's—the other morn I heard the original G9BF holding

forth at length, what time 14 mC/s was wide open for G's. If it wasn't him, it was his understudy, and if he wasn't talking to his crony MO1IFFI then it sounded very much like it. They were both modulating almost raw AC carriers and had lots of joeys either side. Don't you know who G9BF is? Ask G6FO or G6QB.

* * *

The days when 28 mC/s was a band to breed wonderment in the hearts of Hams has long since passed, and nowadays R Max phones from ZL's, W's and parts North, West, East and South are commonplace. There are old-timers who remember the job it was to get fellows to USE the band. Fifteen years ago the population VK there was very scant, but in the desert-

like silence of the band you would always find VK2YC, steadily plodding along.

One wonders if we shall ever think similarly of 50 mC/s. Population there will increase inevitably, as congestion on the other bands gets more acute. This scribe can show you articles written in 1927-8 *appealing* to the gang of that era to "come down and use 20" . . . Yes, there was a time when the 14 mC/s region was mostly receiver hiss and plaintive calls from one or two pioneers. When Chas Maclurcan (A2CM) paved the way to global DX on "twenty" by hooking up with E. Simmonds, late G2OD, it was 1925. The story now makes interesting reading in the "QST" of the period.

* * *

NO PROBATIONARY PERIOD NOW

That probationary period . . . it has gone overboard on the latest PMG edict. Whether or not it proves to be a good thing to abolish it remains to be seen. Most of us hate the very idea of restriction of any kind . . . especially after chafing through a nightmare war of controls on everything except bare essentials. A feeling persists, however, regarding the amateur licence erstwhile probationary period, that in a year or two's time the number and proficiency of amateur telegraphists will decline very considerably. Those who have, back of their mind, tucked away the idea that radio amateurs will again in some future emergency

provide a pool of ready-to-go brass-pounders had better revise their ideas. It will be the same old story—a mere handful—and the necessity for tortuous months of morse class training of those who should have been better equipped telegraphically. Phone is a fine business . . . speedy and satisfying, but this business of inviting the fledgling virtually to "throw his key away" seems a retrograde step. Not all can be good telegraphists, nor for that matter good telephony exponents . . . but there is need for both . . . and hasty scrapping of the probationary period seems not to be in the best national interests.

This scribe has referred to "VFO itis" as something that the hobby can do well without . . . the swish and swoop merchants, and those who try to pirate the other fellow's QSO's . . . but there is another evil that calls for comment. It is that of "Phoneticitis"—the overdone business of place-naming letters. "QR M for Mary" and "QR N for Nelly" are a bit jarring on otherwise steady nerves, Please, you G's, as P. P. Eckersley said so often in early BBC days: "Please don't do it!" W's are bad enough with that "Kay Please."

* * *

Listen to a brief story of what must be the world's No. 1 Ham station and location. Was talking

HAM NOTES

(Continued)

to W6RO on "20" and asked him where was old friend Don Wallace, W6AM. Dwight imparted the gen that Don moved from his old Long Beach QTH to Rolling Hills, Cal., where *he bought bolus bolus the Press Wireless war-time receiving centre*. It totals 103 acres and there are 30-odd 90-foot telephone poles for rhombics. One of W6AM's antennas of that ilk has 3000 feet of wire in it. Just imagine, if we could buy up La Perouse receiving centre—if we had the wherewithal. Meanwhile, pigs might fly!

* * *

Did you read in the daily Press about that Philips development—a revolutionary hot-gas engine? It was brained-up in the Eindhoven labs during the war, under the very noses of SS men! and Gestapo, the while they strutted and ordered. Briefly, it is an advanced form of those kiddie toys we of the Victorian child generation recall—hot-air engines—little gadgets that

buzzed merrily around with the only source of power a spirit flame. The Philips development can be turned out with power development of 200 h.p. or so. It is almost noiseless, has no crankshaft, runs from any kind of fuel that will give heat, and has obvious applications for small cars, watercraft, home lighting, and, by no means least, mobile and field radio equipment. Philips engineers have plenty up their sleeves in other directions.

* * *

Latest bit of bureaucracy—this time in New Zealand. For some weeks now cross-band phone QSO's have been occurring with ZL's on 3.5 and VK's on 7 mC/s (not that VK's can't use 3.5 if they wish to). Suddenly the N.Z. Post Office decreed that the practice must cease if the ZL doesn't have a permit to work on HF bands. Whether or not the ZL is a new hand or an OT—he can hear VK phones on 40 if he listens—the Lord knows. To make fish of one and fowl of the other in the matter of replies on 80 seems a bit steep and

GUIDE POSTS TO G DX

Those who may be constrained to get up in the early morn and go chasing G's on 14 Mc/s phone . . . may or may not be lucky, depending mainly upon the state of the band. It isn't the same two mornings runnings . . . being wide open on one day and like a dense fog the next. There are two prominent G stations that give ample clue to conditions through . . . and if signals from these two are weak, you may as well go back to bed and await another more favourable morning. G6XR, Harry Cook of Kearsley near Coventry, and G8PO. Lt/Cdr. Ted Ironmonger RN of Putney, London have the most consistently strong signal of all G stations. They use very effective antenna systems for the pupose, and if you can't hear them well . . . as I said . . . try again another day brother.

—D.B.K.

prompts the feeling that some of the ZL diehards on 80 may have been suffering pangs of jealousy or something. It is ZL's affair, but even in over-regulated VK the action would be considered high-handed.

* * *

That well-known, VK6 14 mC/s phone, Frank Lambert, VK6FL, had a bit of bad luck in the matter of aerials (who doesn't?). A laboriously tested and erected 2 element beam found itself faced suddenly with an 85 mph gale. Result was inevitable—old man Wind won, as he usually does. But Frank is back on the band with a nice signal in the East from some wire or other.

* * *

Country members of WIA N.S.W. Division have one up now on the poor "City Slicker" member in that the latter doesn't get his copy of "Radiotronics" and Philips Technical Communications posted

F.M. — and other things

Since Major Armstrong got really going with FM VHF broadcasting in experimental form in the early 30's, there have always been two camps . . . for and against. Because primarily for the reason that it discriminates against unwanted background noise, FM has certain advantages, not altogether realised until one experiences it in action. Nevertheless, there are authorities whose opinions command attention, and who consider FM in a rather cold light from some viewpoints. In Britain, engineers of the Pye Company say . . . "It has been customary to regard FM receivers as being generally more sensitive than AM, but equally sensitive AM receivers can be made without any difficulty. As an indictaion of what is now possible with AM, a receiver for frequenes between 80 and 100

Mc/s using only one RF amplifier has been designed with signal/noise ratios of 10db for 1.5 microvolt, and 20 db for 5 microvolts respectively.

The signal/noise ratio must of course, take into account receiver response to external noise fields, both impulsive and random. While FM gives very good suppression of impulsive noise, this can be reduced to such an extent in a noise-limited AM receiver that even very weak signals are not obscured by it. In practice, AM is little inferior to FM so far as signal readability is concerned, although AM has rather more background noise over a certain range of signal strength . . ." So there you are my friends . . . work it out for yourself. This scribe remains neutral at this stage.

any more. He collects them at the monthly General Meeting. If, for some reason such as business as against hobby affairs . . . it isn't possible for him to attend those meetings . . . he misses out for the time being on his copies. It is understood that copies will be kept and may be collected in bulk at later meetings. Which may or may not work out as well as it sounds. 2/6 annually is the fee that the concerns who produce the publications ask of subscribers . . . for posted copies. The concerns make quantities of copies available to WIA for distribution free to WIA members. It is fitting to ensure that members do get copies and that there is no possibility of casual treatment and wastage of valuable printed material.

* * *

Noticed lately that a wide variety of cards from G-land bear the imprint of the one printing concern. Despite the obviously individual ideas of the G's who use the cards, and the consequent difference in colour and design there seems to be no repetition . . . the cards are all different in every respect. That is certainly enterprise on the part of the printers concerned, and they obviously secure the business they deserve.

* * *

Despite the fact that in this modern era morse code telegraphy is surely but very slowly on the way out of fashion, there are lots of early morn VK DX exponents that miss plenty of good contacts with G's and Europeans for the reason that they ignore the CW DX and go all out for the peak period on phone. That is all nice and fine when the band is wide open or approaching that condition, but what of the other periods . . . the times when short skip prevails at the European end? G's can often be heard fairly well on phone at such times, but raising them through their short skip QRM is another matter. At such times the CW signal usually brings results. It is possible to work the CW men for 2 hours ahead of the phone

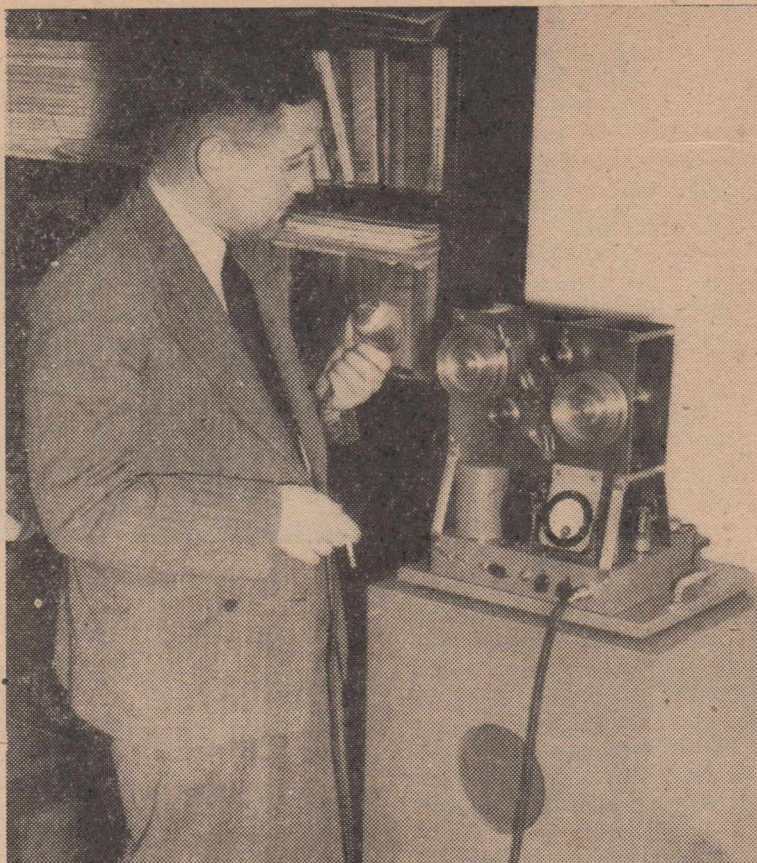

Shown here is Harry Fuller, VK3HF, with his excellent steel wire recorder. This is a home-engineered job, including all patterns for castings, etc. The recorder runs at 2 feet per second, and a spool of wire will record for 1½ hours. Drive is by a 1/60th h.p. synchronous motor with magnetic friction clutches to avoid straining or over-running the wire when stopping. There are three heads, record, erase, and play-back, with different air gaps in each case. Fidelity is good and compares with average Broadcast transcriptions. VK3HF is Manager and Chief Engineer of Station 3YB, Warrnambool, Vic.

men oft-times. But of course, if you are one of those lads who has "thrown his key away" . . . you can't do much about it can you?

* * *

This "Ham" business gets in the blood. And it is of little use the old hand at the game asserting "he has had DX" and is not particularly interested now in that phase of Amateur Radio. Sooner or later he will break away from whatever localised interest he has, and once more go out after DX. Perhaps it won't be the lure of "new" countries but there is a fair measure of attraction in finding one's self

in communication again with a very old friend of the far-off pioneer days of radio communication. Such OT's bob up quite unexpectedly at odd times. For example. I heard none other than Gerald Marcuse himself, the same old G2NM, battling out a nice CW clip on 14 mC/s. For the information of lads who have but recently broken in to this hobby of ours, G2NM ranks high in the history of the Radio Society of Great Britain. Apart from "Ham" radio, he started an Empire Broadcasting Service before the BBC realised that there was "something to the short waves after all."

INTERESTING ENGLISH LETTER

"MV. Chulmleigh,
Avonmouth,
Bristol.

FROM Eric Sherlock, ex-
VK2ANE/MM.

"Dear Don,—You will note from the above address that I am once more back at sea again and this time on another ship.

"Leave passed all too quickly and I didn't do many of the things intended. In fact, I didn't even get on the air, at least, with my own rig. At first I was held up for a power pack and when I ordered the transformers and choke they told me it would be seven-day delivery. Unfortunately Whit holidays came on, which added extra time to the delivery. Eventually I got cracking on building up the power pack. When I tried it on the TX, it functioned O.K. after all its travelling about, but there was a very big hum on the carrier and I didn't like to go on the air with it like that, so I added another section of smoothing choke. I was stuck for a choke but across the road from our shop there is a junk shop which had some Government surplus. I remembered seeing a power pack when I had previously looked over his stock. So I went to see him and he showed me around his back store. There was a radar consol, complete; it was an ex-RAF type and stood about five feet high and three feet square. This chap said 'There are some power supplies in that and if it's any use you can have it for fifteen pounds.' I examined the gear, which was brand new; the only snag was to find out what mains supply this consol was for, as I expected something like 100-volt 500-cycle. Anyway, it had 7 807's, various rectifiers, 24 EF50's and high-voltage condensers, etc. I bought the thing and later, when I took it adrift, found it had rack and sliding units. It was designed for 230/250-volt mains. On ex-

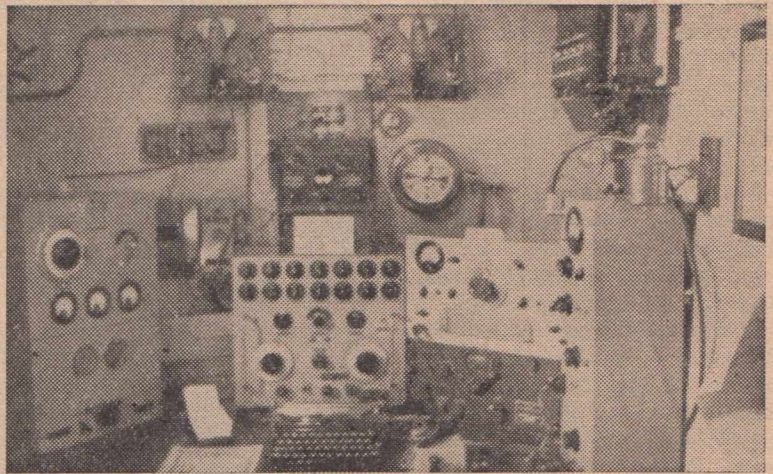

Radio Room of SS "Chertsey. GDLJ—VK2ANE/MM
Eric Sherlock is Now G3BQH.

aming two motors which were in it I found that it was for 50-cycle supply. I then got to work and discovered that I had five power packs, all heavy current types, i.e., 500-mill. efforts, and one a 1250-volt job, the rest being of the 450, 500 and 650-volt class. Also, besides the five power packs, there is one more which has a voltage output around the 5000-volt mark; I haven't had this one on as there is no point of messing around with that voltage for the fun of it. This bargain has altered all plans for my station; I can now go ahead and run power without any large extra cost. I guess I will get the 813 to work.

"The event of buying this radar consol held up my Ham activities, and I have been busy sorting it all out; anyway next time home, I should be able to get on the air rather more quickly.

"You might be interested to know that this chappie had some VHF rx's using magnatrons (tunable efforts) and he didn't know what they were or what they were worth. I think he was selling them for about £3 a set. It's amazing

the gear that is going cheap, if you know where to go for it.

"Well, Don, I suppose you will be interested to know a little about this ship and where we are going to. This ship was built in 1946, so it is quite new. I was very pleased to be appointed to it when I knew how modern she was. But when I went on board I was rather disappointed to find that she had no H.F. TX. But the RX is rather a good job; it's the CR/300/2, and of the new marine type; quite a breakaway from traditional marine gear. It is an eight-valve superhet. wave range continuous from 15 kC/s to 25 mC/s, in eight wave ranges. I haven't studied the circuit yet, but I know they employ two different I.F. frequencies, a high one and a very low one for the long waves. Also there is a very good stepped selectivity control in five steps and at the moment it seems to be better than a x'tal. Another refinement is a x'tal calibrator with a x'tal frequency that marks all the marine bands.

"Another good thing about the station is that the number of wet batteries has been done away with

to a minimum. For HT voltages for the gear they use a vibrator supply working from a 24-volt battery and this supply is in duplicate, so that the only batteries we have are two banks of heavy-duty 24-volt accums. That is a very big improvement. The rest of the gear is the same as the prewar ships. One thing more, the radio room is as big as the chart-room and wheel-house, for once, and each cabin has built-in extractor fans or blower fans, another improvement. Other details of the ship are that she is a Doxford motor job and a little over 5000 tons.

"This voyage is supposed to be carrying us to one of the American Gulf ports and we are to load flour for the Far East, either Hongkong, Shanghai or Singapore. From there we are due to go to Colombo and then back home. Whether this will work out like this I really don't know. I hope that when we get around the Far East that we have a run on your coast. If that happens, although I'll be happy about it, I shall also be a little mad, as I haven't brought any TX'ing gear with me.

"Enclosed are a couple of photos of the Mobile Marine station VK-2ANE. The one showing the tx alone was taken before the finishing touch was put on, i.e., marking of the controls, etc. The top section is the PA with meter switched to read all currents, the next section is the oscillator/doubler with provision for VFO, the next section is the relay panel with mic. input plug, and the bottom section is the mod. The other photo is a view of the radio cabin; on the left is the ships M/F TX; centre is the ship's main RX 15 kC/s to 25 mC/s in ten coil changes; on top of ship's rx is the walkie-talkie used as a VFO; above that is the aerial changeover switches (ship's TX aerials); the two RX on top of each other are the BC 348 r and the KCR11, both used with 2ANE. I think there's enough gen for you, Don."

An "S" Meter for the FS6

THE addition of an "S Meter" to the "FS6" was considered a worthwhile adjunct as the effect of fading can then be observed, also the sending Ham station will want to make experiments in variations of power and comparison of signal strength can always be observed.

Sometimes an amateur will say

By
H. R. FITZSIMMONS
Horsham, Victoria

that very little difference will be noticeable to the ear when he reduces power to a fraction of the original. The ear may record only a noticeable reduction in signal strength but the "S" meter tells a different story. The explanation is that the A.V.C. of the receiver tends to compensate for the signal strength variation.

I spent considerable time experimenting with the "S" meter idea and finally arrived at the following arrangement which gave me excellent results.

The meter used is a Hummalund "S" Meter of 2 inches diameter and calibrated 50-59 from left to right. It may be similar to those advertised for sometime from Disposals dealers. Mine requires 200 micro-amps to deflect to 59, but anything up to maximum deflection of 500 micro-amps. would serve, but probably will require different values for R1 and R2 of circuit.

A word of warning: It is useless to try to fit an "S" meter unless the FS6 receiver has been improved according to my recent article. It simply refuses to operate!

The watch-holder on receiver panel was removed and a hole cut to fit the meter, making sure that it also fits in amongst the components mounted behind. There is sufficient room behind the meter to take the resistors R1 and R2. It was found necessary to switch the meter in as required as a surge

passes through it when switching on receiver and would in time damage the meter. A relic from a "Set No. 22," the "Net" switch which has to be held in the "on" position, was found to be ideal and was mounted in the position occupied by the nameplate in left-hand top corner. The "Speech-CW" switch was transferred to under the phone jacks and correctly rewired. In its place, a small wire-wound potentiometer of 5,000 ohms R1, used as zero adjustment, was mounted under the meter. This arrangement keeps the "S" meter and controls over to the left-hand side and is, of course, a big advantage.

It is to be noted that both the plate and screen current variations, due to the AVC action on V2, are

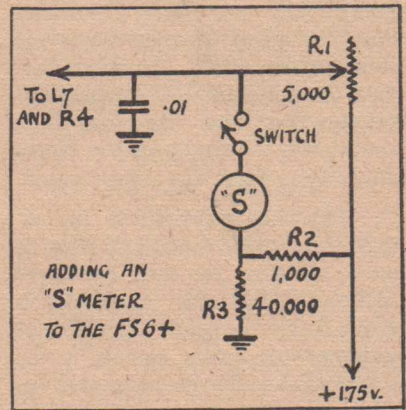

metered, and that the resistors in the network were either computed or found correct by experiment to suit this arrangement.

To operate, set meter on zero, with R1, on no signal, then tune to signal, then note reading; but don't expect very weak signals to do the impossible! If the meter follows signal variations too rapidly for your liking add more capacitance to the AVC line.

An error in the receiver circuit is repeatedly overlooked—the circuit shows socket pins 6 and 5 of V3 (1K7G) connected together; this should not be so.

Shortwave Review

CONDUCTED BY

L. J. KEAST

NOTES FROM MY DIARY—

HOW KEEN A LISTENER ARE YOU?

Under the title Keen Listener, a recent copy of London Calling makes reference to a visitor they had at Broadcasting House. Here is the article in full:

"The BBC recently received a visit from a bank clerk—a Mr. Walmesley—from Halifax, Nova Scotia, one of the most attentive listeners to the BBC's shortwave services we have ever met.

"He was shown round the studios in Oxford Street, and, on going into the Red Continuity Suite, he asked whether it was the studio of the North American Service. On going into the Purple Continuity Suite, he said that that, surely, was the studio of the North American afternoon transmission.

"Somewhat surprised at his remarks, his guide asked him how he knew all this. He then explained that, since listening at home in Nova Scotia, he knew the different transmissions by the sounds of the studio clocks. For instance, said he, the newsroom has a clock with a low dull beat, but the North American Service clock has a much lighter tick, and the North American afternoon transmissions, again, has a clock of a different sound.

"Mr. Walmesley is, indeed, a keen observer of the BBC's short-wave services!"

* * *

WATCH FOR IT

The Canadian Broadcasting Corporation's International Service will make important announcements regarding change in schedules on November 2.

PILLOW TYPE RADIO SETS

Sixty prominent Americans, headed by Jack Benny, recently announced plans to assist in the rehabilitation of wounded servicemen throughout the United States.

The project, which has been in process of formation for several months, will be known as the Hospitalised Veterans' National Foundation, a non-profit, non-sectarian, non-political association.

Immediate objective of the organisation is to provide bedside and pillow-type radio receiving sets to hospitalised servicemen and veterans.

With Jack Benny as president, the group comprises leading business men and public officials, bankers and such personalities as Eddie Cantor, Herbert Marshall, Perry Como, Joseph Cotton, Sophie Tucker, Art Linkletter, Larry Adler, Walter Pidgeon, Rudy Vallee, Louis Bromfield and Sammy Kaye. —WLW Radio News.

* * *

FROM THE SHAKY ISLES

Received the first issue of N.Z. DX-Tra, produced at Auckland. Very nicely typed, but one misses the old familiar names of the DX-ers.

NOTE CHANGE OF TIMES FOR PACIFIC SERVICE

As from Sunday, October 5, the Pacific service of the BBC will be on the air from 4—8 p.m. Listen at 4.10 p.m. on Sundays for programme summary and wave-length details. The service opens daily with the News and Radio News-reel is aired at 4.30. News is given again at 6 p.m. and for those who are lucky enough to be able to listen on Mondays at 5 p.m. they will find ITMA. Yes, it's that man again, Tommy Handley with his usual 30 minutes of fun.

* * *

MAESTRO BECOMES FIGHT FAN

Toscanini's memory for music and musicians is legend. Now the NBC maestro has mastered another category of names—prize fighters. Since he got his television set, Toscanini has become an avid fight fan.

* * *

VERIES IN A NEW FORM

Ed "Archie" Gardner, of NBC's "Duffy's Tavern," is prouder than ever of his famous autographed apron, which bears the personal signatures of hundreds of celebrated personalities. Latest signature acquired by the comedian is that of President Truman.

NEW STATIONS

—, Manila, 11.84 mc, 25.34 m: Rex Gillet reports this new Philippine station which opens at 7 p.m. with "Star Spangled Banner." The only announcements are made each hour on the hour, as follows: "This is the U.S.A. testing from Manila on a frequency of 11,840 kcs in the 25 metre band." The station is very powerful and is still on after midnight. Programme is entirely of

recorded music, it is spoilt by VLC-7 when the "Radio Australia" programme opens at 10 o'clock for North America (East Coast).

RADIO VIENNA, Austria, 9.57 mc, 31.35 m: This new outlet is reported by Arthur Cushen who says they open at 2.45 pm with devotional type programme and news in German is given at 3 o'clock.

SAYS WHO?

Here are some fine notes by air mail from "Radio News", Chicago.

Algiers. The 11.837 mc outlet appears to have changed skeds; heard signing off at 9 am.

Austria. Radio Wien, Vienna, sked.: Monday 11.789 mc, 6.155 mc, 2.55 pm—8.05 am and from 7.30—8.05 am also on 7.175 and 9.662. Rest of week is same except sign-on is at 2.45 pm.

Argentina. Letter in Spanish received by Sid Pearce, England, from Jefe Radioelectrica. Ushuai, Tierra del Fuego, states station L5PS is owned by La Administracion General de Correos y Telecomunicaciones and says frequencies are 14.850, 10.330, 7.425, 6.430 and 3.215 mc with 1 kw power.

Germany. Hamburg, 6.115 mc, 2 pm—8 am. Interval signal is melody from Mozart's *Zauberflute*.

Ireland. Radio Eireann, 9.595 mc again heard in North America with news at 7.10—7.30 am.

Northern Rhodesia. ZQP, Lusaka, now on proper frequency, 7.220 instead of 7.285 mc; error was due to faulty crystal, now replaced.

South Africa. South African Air Forces soon to operate from studios in Pretoria. Will use 5 kw on 7.40 mc.

Trinidad. VP4RD, Port-of-Spain now back on air; sked is 9—11 pm; 2 am—4 am; 6 am—1 pm on 9.625 mc. Call soon to be changed to a "Z" one. So far signals poor . . . carries many BBC relays.

(Many thanks, Ken.—L.J.K.)

* * *

Here is Arthur Cushen's list of loggings:

Batavia, 9.68 mc, with English news at 8.30 pm.

Far Eastern Broadcasting Service, Singapore, 9.69 mc, heard after GRX signs at 7 pm; Chinese at 7 pm; French at 8.30, relays the Purple Network.

Vienna, Austria on 11.78 and

9.57 mc, latter a new outlet, opens at 2.45 pm with devotional type programme. News at 3 pm in German.

Damascus, Syria, 500 watts 6.00 mc, good signal at 5.30 a.m. . . . French-Arabic programme.

Unidentified on 5.99 mc. German station . . . good signal . . . gives relay stations at 5.30 am.

BIAK, New Guinea heard calling Batavia at 9 p.m. on 7.20 mc . . . signs off at 9.30 p.m. with "End Of A Perfect Day." Schedule seems to be 8-9.30 p.m.

HC4EB, Manta, Ecuador. "Radio Manta" often announced. Is heard now on regular schedule on 6.87 mc; Has clock chiming twelve at 3 p.m.; signs at 3.05

TGQA, Quezaltenango formerly on 6.401 mc is now on 6.90 mc till 3.05 p.m.

CBLX, 15.09 mc gives news at 9 p.m.: Heard also signing off at 2 p.m. next day.

CHLS-CHOL, terrific in South Pacific service. I had cable last week asking for special monitoring report on Davis Cup transmissions.

The 13 metre band is active at 6 a.m. . . Best heard are WNRX 21.73 mc; GVS, 21.70 mc; GVR 21.67 mc; GRZ, 21.64 mc; WNRA, 21.60 mc; WGEA, 21.57 mc; GSJ, 21.53 mc and WOOW, 21.50 mc.

RADIO ROUMANIA LIBRE, very strong on 6.20 mc. English news at 5.30 a.m., then orchestral prog. from 5.40-6 a.m. when station signs in English. Location given as Aleca Zee2, Bucharest. Have reported this months ago no veri received.

RADIO ANDORRA, very good 7-7.15 a.m. in English on 5.98 mc.

XGOA, heard on a new channel, 9.452 mc at 9.30 p.m. . . . All Chinese.

* * * * *

Rex Gillett of Adelaide advises: LUXEMBOURG: The complete schedule of Radio Luxembourg's

tests are as follows: 2.10-3.10 p.m. on 15.35 mc; 3.10-3.30 p.m. on 6.09 mc; 8-8.40 p.m. on 15.35 mc; 8.40-9 p.m. on 9.527.5 mc; 3-3.40 a.m. on 15.35 mc; 3.40-4 a.m. on 9.527.5 mc and 5-7.30 a.m. on 6.09 mc. I have been able to tune the last three transmissions here. They consist of recorded music with announcements in French, German and English.

BELGIAN CONGO: Leopoldville is using 11.625 mc to sign off at 7.45 a.m. Programme is in English but call and frequency are wrongly quoted as OTC-5 on 17.770 kilocycles. Strength is very fine.

SPANISH MOROCCO: Radio Teheran has been heard to announce as "Radio Nacional de Espana" at 7 a.m. after what seemed to be rews, read by male and female. This is, no doubt, a relay from Madrid. Signals are quite good here now on 6.065 mc.

FRANCE: "Allo Brazzaville ici Paree" is announced at 3.30 a.m. on 15.35 mc. Luxembourg causes interference.

ROUMANIA: Bucharest heard closing one hour earlier. Sign off is now 4.30 a.m. after English broadcast.

ANGOLA, CR6RB is still being logged with fairly good signals on 9.165 mc until sign off time at 5 a.m., with the Portuguese National Anthem.

BECHUANALAND: ZNB is another station being heard again before it signs off at 5.30 a.m. with "God Save The King." Recorded music, with occasional announcements, constitutes the programme.

JAPAN: Tokio is being heard in the Home Service on 6.19 mc from about 7 p.m. The 6.005 mc channel is heard occasionally at 6 a.m. (Thanks Rex . . . that's a fine and interesting list.)

* * * * *

The Pacific Service from the "Happy Station" PCJ, Hilversum in Holland, now commences at

7 p.m. on Tuesdays, one hour later than previously. PCJ is local station volume from opening on 15.22 mc 19.71 met. Weaker signals may be tuned on 17.77 mc 16.88 m at the same time.—"Radio Call."

* * *

Miss Dorothy Sanderson sends fine list of loggings:-

U.S.A.: KCBF, 25.40, 11.81 mc, 6.0 p.m., news and music.

KCBA, 19.81, 15.15 mc, 6.15 p.m., musical programme.

KCBR, 19.81, 15.15 mc, 7.0 p.m., news.

WNRE, 19.63, 15.28 mc, 8.45 a.m., news.

KHRO, 19.67, 15.25 mc, 7.0 p.m., news and music.

KGEX, 25.57, 11.73 mc, 8.45 p.m., evolution of the printing machine, news.

WRUA, 19.53, 15.35 mc, 8.15 a.m., talk on Utah State, news.

KNBA, 13.87, 21.63 mc, 8.30 a.m., news and music.

WGEA, 19.61, 15.30 mc, 8.45 a.m., frequency details, music.

WCDA, 13.89, 21.57 mc, 11.45 a.m., programme to Latin America.

KWIX, 25.22, 11.89 mc, 7.0 p.m., news and music.

KGEI, 19.72, 15.21 mc, 7.45 p.m., news and music.

KWIX, 31.35, 9.57 mc, 6.15 p.m., variety programme and music, news.

KCBA, 30.79, 9.75 mc, 7.0 p.m., news and music.

KWID, 31.35, 9.57 mc, 10.0 p.m., Far Eastern Service, music and news.

KNBA, 13.88, 21.61 mc, 11.45 a.m., variety show and news.

AFN, 49.36, 6.08 mc, 7.0 p.m., musical programme.

WMI, 46.68, 6.47 mc, 9.5 p.m., weather reports on Great Lakes.

KNBA, 31.09, 9.65 mc, 7.0 p.m., news and review.

KNBI 25.57, 11.79 mc, 7.15 p.m., programme preview, and news.

WRUL, 25.57, 11.73 mc, 1.30

p.m., Latin American Service, news and music.

KWID, 25.21, 11.90 mc, 9.0 p.m., news and music, Kate Smith Show.

WRUL, 25.57, 11.73 mc, 7.30 a.m., United Nations programme, news and music.

KGEI, 19.83, 15.13 mc, 6.30 p.m., musical programme.

KNBX, 19.57, 15.33 mc, 4.30 p.m., music and news.

WNBI, 16.85, 17.80 mc, 2.45 p.m., Latin American Service, music and news.

WRUA/L, 19.53, 15.35 mc, 2.30 p.m., Latin American Service, news and music.

WGEA, 25.40, 11.81 mc, 8.15 a.m., American News Letter, music and news.

KCBF, 25.40, 11.81 mc, 2.30 p.m., music from America, news.

VONH, 50.55, 5.97 mc, 6.45 a.m., fair signal, musical programme.

OTC2, Leopoldville, 30.84, 9.74 mc, 9.15 a.m., news in French and English, music.

OTC5, Leopoldville, 25.60, 11.72 mc, 7.15 a.m. news in English and music. Announced as OTC5 on 11.72 mc.

FHE3, Dakar, 25.62, 11.71 mc, 7.15 a.m., news in French and music.

RADIO TETUAN, 49.49, 6.06 mc., 7.30 a.m., news in Spanish and music.

* * *

BBC PACIFIC SERVICE

At time of writing these notes I have not heard the frequencies announced for the change in schedule commencing on Sunday, October 5, but I hazard a guess they will most likely be:

FOR AUSTRALIA

GRX, 9.69 mc, 30.96 m: 4—8 pm.

GSN, 11.82 mc, 25.38 m: 4—8 pm.

GSP, 15.31 mc, 19.61 m: 4—8 pm.

GVS, 21.71 mc, 13.82 m: 4.45—8 pm.

N.Z. AND PACIFIC AREA

GVZ, 9.64 mc, 31.12 m: 4—8 pm.

GSN, 11.82 mc, 25.38 m: 4—8 pm.

GRD, 15.45 mc, 19.42 m: 4—8 pm.

GRQ, 18.025 mc, 16.64 m: 4—8 pm.

* * *

HELP WANTED

They're hard to catch if they stump Rex Gillett, but he sends a list of some that have him tricked. If you can identify them drop me a note.

Here they are:

A station on about 9.21 mc, 32.55 m was heard with a French (?) type of language and native music until it signed off at 4.30 am with an unknown march. I am wondering if this is OQ2RC. (Would it be YFA-4, Macau, Portuguese China? . . . they are on at that time on 9.23 mc, 32.48 m.—L.J.K.)

A native type programme has been logged on 12 mc until sign off at 6 am with an unusual anthem. A few weeks earlier, about 4.30 am, the programme seemed to be of a Spanish flavour on this spot.

Who, I wonder, is the station heard to sign off on 6.095 mc at 10 o'clock with a French type programme?

A Latin, heard on about 5.87 mc, has been giving organ numbers till 10.30 pm, when clock chimes similar to London's Big Ben were heard.

Another Latin on about 6.155 mc was heard with physical jerks from 11 pm. The gymnastics lasted for about half an hour.

Arthur Cushen is hearing a German station on about 5.99 mc at 5.30 am. Signal is good and it gives relay stations at 5.30 am. Can anybody help here? (Is this one of the many Russian outlets?—L.J.K.)

VERIFICATIONS

Here is Arthur Cushen's list:

The most interesting verification received here recently is RAIDO MONTE-CARLO, Monaco, 300 watts on 6.130 mc . . . will be going up to 25,000 watts on November 1. Veri. was by letter in French, two photos and an interesting booklet. Schedule is 5.30—6.30 pm, 10 pm—M/n. and 5—9.15 am. (This station was reported by Ern. Suffolk on September 6, '46—but I do not know if he got a verification.—L.J.K.)

LUXEMBOURG, 6.09 mc, veri. by letter, English period is: 5—7.30 am on Mondays . . . was testing recent Sunday evenings at 5 pm on 6.09 mc. Arne Skoog air mails news that Luxembourg is testing on 15.35 mc at 3.30 am.

YV5RU, Caracas (Venezuela) 4.86 mc, verified with an attractive card. Other recent verifications here are: HEU5, 15.315 mc; FBS, 7.22 mc, Jerusalem; XECC, 6.185 mc, 50 watts, veri by air mail; VUM-2, 4.92 mc; Kuala Lumpur; WLWR, 9.7 mc; WLWL, 17.995 mc; WRUW, 17.75 mc; WRUS, 15.13 mc; VLC, VLC9, VLA7, CKCS, CKRA.

Monte Carlo was my 99th country to be verified. (Very good, Arthur, and congrats.—L.J.K.)

* * *

Rex Gillet says: "Veries have been few and far between so far this month. The best ones received

NEW ZEALAND SHORT-WAVE STATIONS

In September issue I referred to ZL-2, Wellington being heard. Information has now reached me by medium of Tune in Radio Bulletin which says this of the broadcast.

* * *

"RADIO HISTORY.

The National Broadcasting Service short-wave stations ZL-2 (9540) and ZL-3 (11780) took the air for the first time on a Special transmission on Monday, August 11th, 1947, beamed to Australia, which was a relay of the John Charles Thomas concert in

Auckland. The two 7½ kw transmitters, using 31 and 25 metre aerials (19 is also up with 49 or possibly 16 to be erected) beamed on Sydney (285 degrees) took the relay. Another set of four aerials to be used for a regular service to the Pacific (beamed 15 degrees east of north) have yet to be erected, so this service will not be in operation for some time.

We point out that this was a SPECIAL transmission, and we have no information as to when the regular service is to commence, but will keep members posted when the information comes to hand."

being: Saigon, 6.165 mc; Dakar, 15.38 mc; ZQP, 7.285 mc; and 9.71 mc, and Siam 6.13 mc. Radio Saigon on 1050 kc stated mine was the first report from Australia.

* * *

THE CROSLY CORPORATION Shortwave Frequency Schedule Australian Eastern Standard Time

WLWK
3 a.m. — 8 a.m. — 15250 kc —
19.7 mt — Europe.
9 a.m. — 3 p.m. — 15250 kc —
19.7 mt — W. South America.

WLWO
3 a.m. — 8 a.m. — 17800 kc —
16.8 mt — Europe.
* 9 a.m. — 10 a.m. — 11790 kc —
25.4 mt — E. South America.

11 a.m. — 1 p.m. — 11790 kc —
25.4 mt — E. South America.

WLWR
3 a.m. — 8 a.m. — 15130 kc —
19.8 mt — Europe.

15130 kc —
19.8 mt — North Africa.
10 a.m. — 3 p.m. — 9700 kc —
30.9 mt — W. South America.

WLWS
3 a.m. — 8 a.m. — 21650 kc —
13.2 mt — Europe.
21650 kc —
13.2 mt — North Africa.
21650 kc —
13.2 mt — W. South America.
10 a.m. — 3 p.m. — 11710 kc —
25.6 mt — W. South America.
* Daily except Monday

GEORGE BROWN & CO. PTY. LTD.

267 CLARENCE STREET, SYDNEY. Phone: M 2544

DISTRIBUTORS TO THE TRADE FOR

ROLA SPEAKERS ● EVEREADY BATTERIES ● AEGIS
RADIO COMPONENTS ● ULTIMATE RADIOS ● MULLARD
VALVES ● I.R.C. RESISTORS

And All Brand Line Radio Components

★ AEGIS 4 VALVE AND 5 VALVE KIT SETS COMPLETE NOW AVAILABLE

Speedy Query Service

H.G.L. (Hamilton) finds that his "Personal Portable" runs the battery down quickly.

A.—We have no figures on the life of Australian-made "B" batteries, but the American figures for the Mini-max 467 indicate that it should run about 20 hours if the drain is 10 milliamps, and 11 hours if the drain is 15 milliamps. This reckoning presumes intermittent use of three or four hours per day. With the 467 listed at about 17/- you can expect your running costs to be more than 1/- per hour. If you fitted heavier batteries they should give you some hundreds of hours of running and reduce your cost to a fraction.

E.P. (Port Pirie) has a set which is giving trouble. He sends a copy of circuit and some voltage readings which he has made.

A.—The trouble seems to be that the converter valve is not oscillating. Make sure that the earthing of the gang and the associated by-pass condensers is efficient in every case. Make certain by connecting them all up with a piece of heavy gauge wire. Try fitting another .1 mfd. condenser in parallel with the by-pass condensers one by one and see if one of them is open circuited. Your voltage readings are not very helpful on account of the comparatively low internal resistance of the meter. The

A.—The values given were those used in the original chassis, and it would appear that the output valve does not work under the operating conditions normally specified by the valve manufacturers. This does not mean that anything is wrong, as there are alternative ways of operating valves, and those given in charts are usually merely a guide to optimum power output, distortion level and so on. It is possible to run the 2A3 under several different sets of conditions and still get completely satisfactory results. Bias can be anything from 40 to 60 volts, giving plate current of from 60 to 40 milliamps. It is always safest to operate valves as recommended in the valve charts, and so we suggest that you use a bias resistor of 2,500 ohms instead of the 4,000 shown, and the rest of the circuit should balance up O.K. It is always nice to have a voltmeter on hand when you are working on direct-coupled amplifiers.

PHILIPS
MANUAL OF RADIO
PRACTICE
 FOR SERVICEMEN

A MUST-HAVE FOR EVERY
Serviceman • Engineer
Amateur • Experimenter
Student

496 PAGES • 250 DIAGRAMS • 400 FORMULAE • 105 CHARTS AND TABLES • 122 VALVE CURVES

PRICE
22/6
 POSTAGE PAID



To Philips Electrical Industries of Australia Pty. Ltd., Box 2703C, G.P.O., Sydney.

Please forward post-free to the address below one copy of the Philips Manual of Radio Practice for which I enclose cheque/postal note for 22/6.

NAME _____

ADDRESS _____

A.R.W.3

OR OBTAINABLE FROM ALL LEADING BOOKSELLERS

G12

VADE MECUM

Readers who noticed our recent review of the Radio Tube Vade Mecum will be pleased to know that copies are now available from Angus and Robertsons, 89 Castlereagh St., Sydney, price 19/6. The book, which is published in Belgium, lists every type of valve in the world, including those used by the German and Russian armies in their war-time equipment.

voltage on the oscillator plate seems too low. Make sure that you have a feed resistor with a red body and an orange dot, not a yellow dot. If you have a yellow dot the resistor is 250,000 ohm, and this would explain the whole trouble. Try a piece of wire to short out this resistor, putting full h.t. on the oscillator plate for a moment or two to see if it then works. Don't run the converter for a long period in this condition, however. To be quite sure about whether the 6A8G is oscillating you can lift the 50,000 ohm grid leak off its "earth" and insert an 0 to 1 milliammeter in circuit. Grid current should be .4 of a milliamp if everything is in order.

B.C.P. (Albert Park) queries the resistors specified for the direct-coupled Ferrotune circuit recently published.

R.S. (Surrey Hills) wants a picture diagram for the wiring of the Ferrotune mantel model described in the November 1946 issue.

A.—Sorry, but we are unable to give you a picture diagram of the wiring of this set. The chassis has long since left our hands and it would not be possible for us to draw one up without referring to the original. However, it was a very simple set to wire, the coil unit being completely wired in itself, and we doubt if you could run into any trouble if you keep on eye on the photograph of the original chassis.

B.L. (Carrum) asks why many circuits show a .1 mfd. condenser in parallel with the second filter condenser from h.t. to earth.

A.—This condenser is added as a precaution to avoid instability, which may otherwise occur. The electrolytic condenser is not a good by-pass for r.f. Although the capacity is 8 microfarads as against .1 mfd. for the tubular condenser, the power factor of the electrolytic may be so poor that it will offer considerable impedance to r.f. Often enough the set will operate without the tubular condenser, but it is still good practice to leave it in circuit in case the characteristics of the electrolytic deteriorate later.

RED  LINE

EQUIPMENT

Precision in Design and Construction

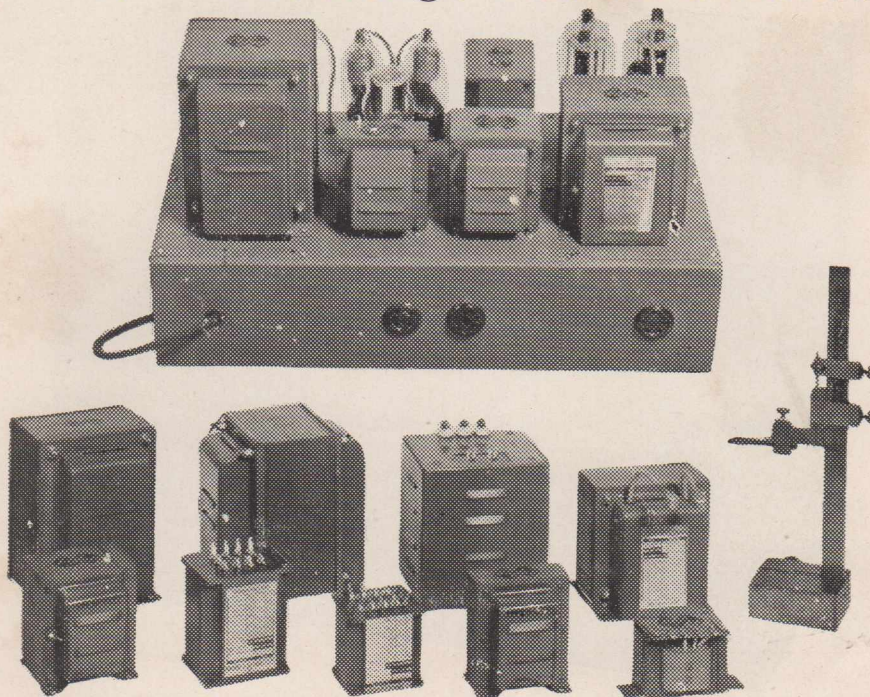

Red Line Equipment Includes:

- High Tension Plate Transformers
- Low Tension Filament Supplies*
- Class B Driver Transformers
- Multi Impedance Modulation Transformers
- Heavy Duty Power Supplies
- Swinging and Smoothing Chokes
- Wide Range Audio Equipment
- Frequency Dividing Networks
*(*Insulated up to 4000 volts if Required)*

SWALES & SWANN

Technical Service, Wholesale and
Manufacturers

A. T. SWALES, Gen. 4773
2 Coates Lane, Melbourne

A GUARANTEE



Trade Sales: Allen SWANN

MU 6895 (3 Lines)

157 Elizabeth Street, Melbourne

OF DEPENDABILITY

YOU WAITED FOR IT!
HERE IT IS! THE NEW

SIGNAL TRACER!

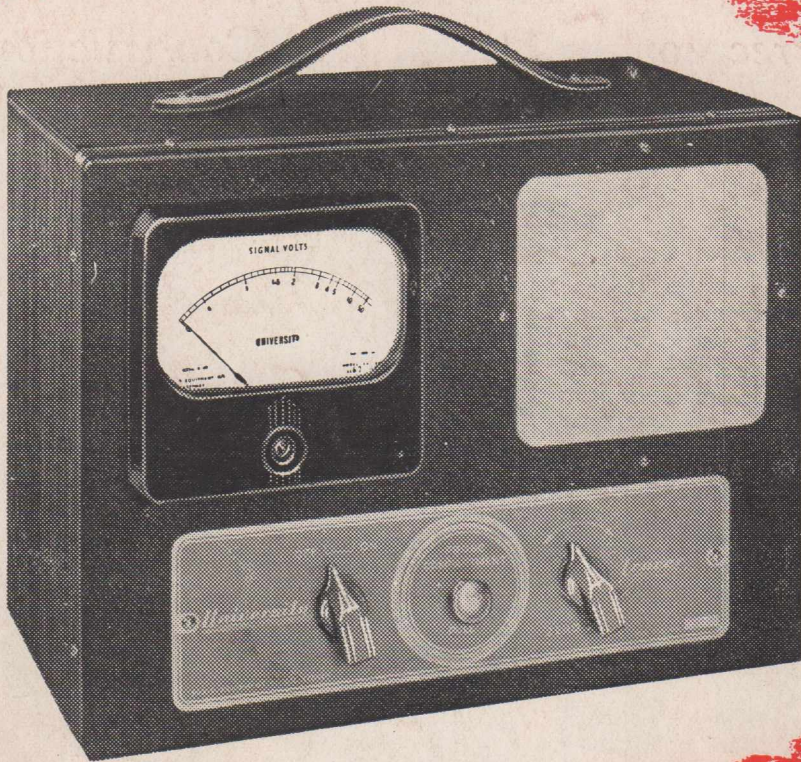

ANOTHER "FIRST" FROM *University*

WHAT IT IS . . .

It's a Signal Tracer—the most versatile and fool proof instrument that has ever been designed for speedy and economical radio service work and general fault finding. It is built into an attractive brocaded steel case with a leather carrying handle and all necessary tests leads and instructions are supplied. It embodies one of the famous "University" four inch square meters together with a new $3\frac{1}{2}$ " permanent speaker. Standard type easily replaceable batteries are built internally and a book of instructions explains the uses and shows how signal tracing is the latest up-to-date method of service work. You hear the signal in the speaker—and you see the signal on the meter.

WHAT IT DOES . . .

Spearhead of this most efficient instrument is the probe. This is a bakelite moulding into which is built one of the new spearhead bantam type valves. It actually traces the path of the signal RIGHT THROUGH the radio receiver from START TO FINISH. It can be used just as effectively on amplifiers or intercommunication systems and will give the same effectiveness and speedy service. When the probe strikes the faulty section, indications are given by the meter and speaker both. It will indicate clearly and easily faults in coils, condensers, intermediate frequency transformers, components as the signal is traced. This is the instrument you MUST have—a necessity in every place where radio work is being done. Ask for Model S.T.B. "University" Signal Tracer.

WHERE TO SEE IT . . .

N.S.W.: John Martin Pty. Ltd., George Brown & Co. Pty. Ltd., Fox & MacGillycuddy Ltd., Bloch & Gerber Ltd., Dominion Factors Pty. Ltd., Electronic Parts Pty. Ltd., VICTORIA: Veall's Electrical & Radio Pty. Ltd., Replacement Parts Pty. Ltd., Hartley's Ltd., John Martin Radio & Electrical, J. H. Magrath & Co., Arthur J. Veall Pty. Ltd. QUEENSLAND: Chandlers Pty. Ltd., Irvine Radio & Electrical Co., Trackson Bros. Pty. Ltd., A. E. Harrold. SOUTH AUSTRALIA: Gerard & Goodman Ltd., Radio Wholesalers Ltd., Unbehaun & Johnstone Ltd. WESTERN AUSTRALIA: Atkins (W.A.) Ltd. TASMANIA: W. & G. Genders Ltd. NEW ZEALAND: Allum Electrical Co. Ltd.

Price
£14.0.0
Plus Tax

Made by **RADIO EQUIPMENT PTY. LTD.**

5 NORTH YORK ST., SYDNEY
Phones: B 3678, B 1960, M 6391