

THE AUSTRALASIAN

J. Petrus

Registered at the G.P.O. Sydney, for transmission by post as a periodical.

Radio World

1/-

VOL. 11 NO. 7

DECEMBER 15, 1946

ANISOTROPIC ALNICO

OPENS UP ANOTHER NEW FIELD IN RADIO

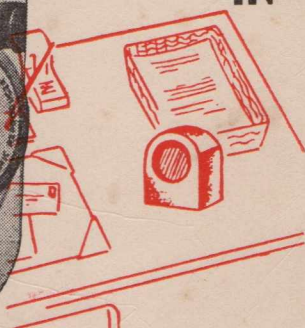
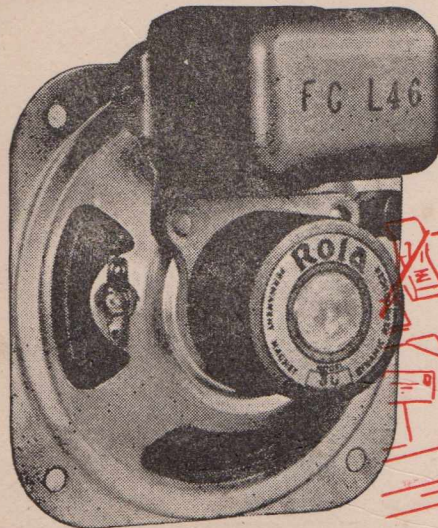

Here are the technical specifications of 3C
 Cone housing 3 9/16 in.
 Baffle opening 2 3/4 in.
 Depth of speaker (padding to rear plate) 1 1/2 in.
 Depth (including isocore transformer) 2 1/4 in.
 Voice coil impedance 3.7 ohms

AUSTRALIA'S SMALLEST LOUDSPEAKER

Made possible by the use of anisotropic alnico, the new Rola 3C Speaker is small enough to fit snugly into the palm of the hand. Weighing only 6 1/2 ozs., the 3C facilitates the design of the small portable receiver, and is ideal for

application to compact communication systems. Shortly to be released is 3C as illustrated. The entirely new isocore transformer, specially designed for small Rola speakers, completely eliminates the bogey of battery-operated receivers—electrolysis.

Your distributor will shortly have limited stocks

ROLA
3C

ROLA LOUD SPEAKERS with ANISOTROPIC ALNICO

ROLA CO. (AUST.) PTY. LTD., The Boulevard, Richmond, Victoria. 116 Clarence Street, Sydney.

Xmas again

... and it's been a busy year for us all in the Radio trade. We would like to get around to our many good friends in the trade to say "Cheerio," but as we can't manage this we take this opportunity of wishing you all a Merry Xmas and thanks a million for the many favours of 1946.

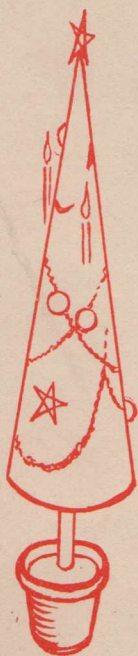

Crown



RADIO PRODUCTS PTY. LTD.

51-53 MURRAY ST.

PYRMONT, SYDNEY. TELEPHONE: MW 2628

THE AUSTRALASIAN RADIO WORLD

Devoted entirely to Technical Radio

and incorporating
ALL - WAVE ALL - WORLD DX NEWS

★ EDITOR
★ PUBLISHER
★ PROPRIETOR—
A. G. HULL
Balcombe St., Mornington,
Vic.

★ SHORT-WAVE EDITOR—
L. J. KEAST
6 Fitzgerald Road, Ermington,
N.S.W. Phone: WL1101

★ HAM NOTES By—
D. B. KNOCK (VK2NO)
43 Yanko Av., Waverley, N.S.W.

★ ADVERTISING
REPRESENTATIVE FOR VIC.—
W. J. LEWIS
20 Queen St., Melbourne
Phone: MU 5154

★ ADVERTISING
REPRESENTATIVE FOR N.S.W.—
**AMALGAMATED PUBLICATIONS
PTY. LTD.**
83 Pitt St., Sydney
Phone: B 1077

★ SUBSCRIPTION RATES—
6 issues 5/3
12 issues 10/6
24 issues £1
Post free to any address in
the world.

Address for all correspondence:
AUSTRALASIAN RADIO WORLD
Balcombe St.
Mornington
Victoria

VOL. 12. DECEMBER, 1946 No. 7

CONTENTS

CONSTRUCTIONAL—	
High Quality Multimeter	5
Build Yourself an F.F.R. Amplifier	75
TECHNICAL—	
Cracking the Oyster	11
Radiotron Applications Laboratory	26
Calling CQ	27
SHORTWAVE REVIEW—	
Notes From My Diary	38
THE SERVICE PAGES—	
Answers	34

EDITORIAL

How times have changed!

Before the war we used to run special Christmas issues, with many extra pages of editorial matter and dozens of extra advertisements, mostly directed at drawing in more business for Christmas.

This year the position is very different. Even some of our keenest supporters are asking us to leave out their advertisements because they already have more business than they can handle and they just don't know how they can possibly get through the Christmas rush.

Twelve months ago we were looking forward to all sorts of good things; we expected that communications-type receivers would be available in hundreds at reasonable prices; we hoped that everything would be back to normal within six months.

Now, as the year draws to a close, we look back and find that there have been many disappointments—the communications-type receivers have not materialised, even the old-style components have not come through in anything like sufficient quantities to meet demands. In our own particular line the paper situation showed signs of improving, and we managed to get hold of a little amount of paper of almost pre-war quality, but this is getting harder and harder to obtain and we may yet be forced to go back on to the poorer quality newsprint which we had to use during the war.

It all seems such a pity, for now is the ideal time to attain the millenium. If everybody who is capable of working would concentrate on doing something useful in the way of production, we could soon reach a state of affairs where everybody would be able to have everything they can think of: a new car, new home, new furniture, new radios. It only needs a successful production drive instead of strikes, go-slow policies and lack of initiative.

—A. G. HULL.

Build your own MULTIMETER!

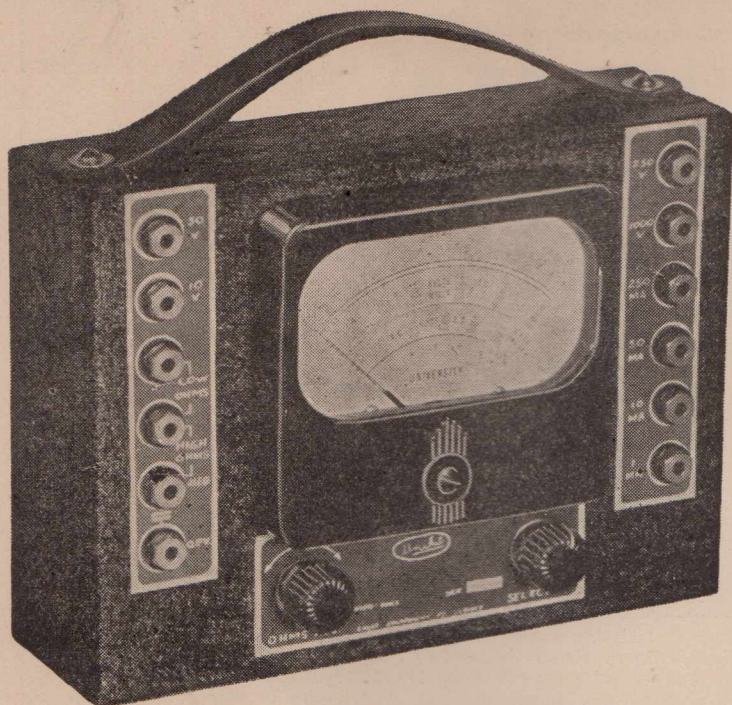

Easily constructed with a few simple tools, the new MK1 uses the popular four-inch square meter with clear multi-scale. Featuring extensive ranges, the finished instrument compares favorably with commercial models. Selected components ensure a high order of accuracy. It comes complete with full wiring and constructional details—circuit diagrams and photographs make assembly easy.

RADIO EQUIPMENT Pty. Ltd.

375 KENT ST., SYDNEY,
N.S.W.

Telephones: M 6391-2
Telegrams: "Raquip,"
Sydney.



DISTRIBUTED BY

N.S.W.: All leading Distributors.
Queensland: Irvine Radio; J. B. Chandler Pty. Ltd.; A. E. Harrold.
Victoria: Vealls Electrical & Radio Pty. Ltd.; Hartleys Ltd.;
Replacement Parts Pty. Ltd.

South Australia: Gerard & Goodman Ltd.; Radio Wholesalers Ltd.
Western Australia: Atkins (W.A.) Ltd.
Tasmania: W. & G. Genders Pty. Ltd.
New Zealand: Allum Electrical Company Ltd.

RANGES

DC volts: 0/10, 0/50, 0/250, 0/1000.
AC volts: 0/10, 0/50, 0/250, 0/1000.
Output volts: 0/10, 0/50, 0/250,
0/1000.
DC m.a.: 0/1, 0/10, 0/50, 0/250.
Ohms: 0/1000, 0/100,000.

Available from all leading distributors—
Write now for details.

NOW AVAILABLE

"University"

MULTIMETER KIT

MODEL MK1

Prices:

AC/DC Kit: £7 12s. 0d

D/C Kit: £6 0s. 0d.

Plus 10% Sales Tax

HOW TO BUILD A HIGH-QUALITY MULTIMETER

JUST recently released is a new Multimeter Kit, which will be very interesting to all enthusiasts. It is an accurate and comprehensive instrument which can be constructed with a few simple tools, and which will compare very favourably in performance with many of the more expensive instruments. One great fact that will be of assistance to home-builders is that all voltage multipliers, shunts, meter, etc., have been carefully pre-adjusted in the factory so that if assembly is carried out according to these instructions, accurate readings will be made with the Multimeter.

MOST UP-TO-DATE

The new kit has been pioneered and released by Radio Equipment Pty. Limited of Sydney. For many years past they have been pioneers in the construction of kits, and it is refreshing to see a modern and up-to-date instrument made available in kit form, particularly in view of the fact that shortages are so worrying these days. By carefully reading



Photograph of the finished multimeter.

these instructions, the instrument will give a great deal of profitable use and pleasure to the user.

First of all, here is a list of the parts contained in this kit; they are all in this kit, although some of the smaller parts will undoubtedly be assembled. For example, the four bolts for mounting the meter are

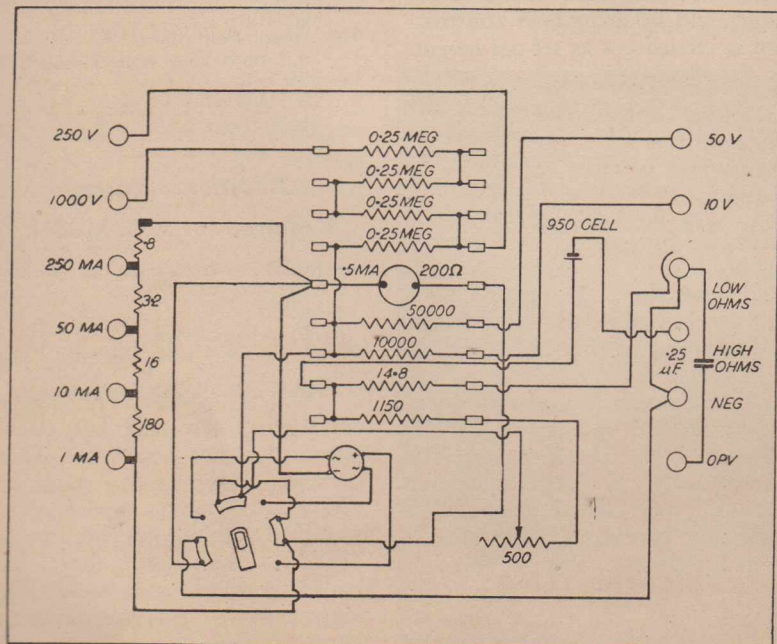

Schematic circuit for the multimeter.

By
THE ENGINEERING STAFF
RADIO EQUIPMENT PTY. LTD.
SYDNEY

already screwed into the back of the meter. Therefore, when checking the parts over, take into account that some parts are assembled on to others, and you will find everything complete.

(Continued on next page)

Radiokes

THE NAME TO KNOW IN RADIO!

Radiokes

RADIOKES D.W. UNITS. Highly selective with exceptional wide range. To match 'H' type gang condenser. Incorporates 4-in-1 padder. Solidly mounted with coils. Ask for type DWO-1

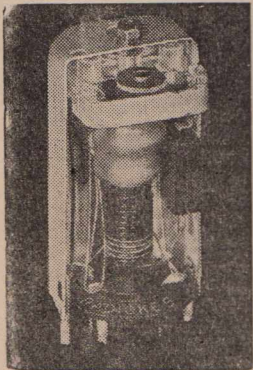

When buying radio parts and components, follow the lead of amateurs and experts alike — specify Radiokes — your guarantee of test-set performance, precision construction and technical excellence.

RADIOKES
PTY. LTD.
P.O. BOX 90
BROADWAY — SYDNEY

R-56

MULTIMETER

(Continued)

The details for building that follow will be for building the D.C. Multimeter. If you have purchased this kit for DC only, you need not read any further than the finish of the D.C. construction. On the other hand, if you have purchased the kit for the AC/DC model, you will have to build the DC portion, and then you can go on and read the AC section, and complete the whole building to make it an AC/DC Multimeter. For those who have purchased the DC Model only, it is suggested that you keep this instruction sheet, because if you desire to build the AC part later on, these few simple pieces can be purchased, and the instructions that apply to A.C. will help you to finish your Multimeter at any later date.

When completed, this Multimeter will have a number of ranges. The D.C. version will have the following ranges: 0/10, 0/50, 0/250 and 0/1000 volts D.C., 0/1, 0/10, 0/50 and 0/250 milliamperes D.C., 0/1000 and 0/100,000 ohms D.C. The A.C./D.C. version will have exactly the same ranges with the addition of the following: 0/10, 0/50, 0/250 and 0/1,000 volts A.C., 0/10, 0/50, 0/250 and 0/1000 output volts. All of these ranges will be accurate if construction is carried out as set out herein.

ASSEMBLY

The first step in constructing the Multimeter is to assemble those parts that are to be first wired. On opening up the kit, you will find that some parts have been partly assembled for you. The front panel has been partly assembled. The tip jack socket assemblies also hold the side labels against the front panel, and sufficient of these have already been assembled to achieve this, and at the same time, to enable you to copy a method of assembly for the balance of the tip jack sockets. The "Low Ohms" tip jack socket is a special double contact type, and to avoid any confusion it has already been assembled. Take the rest of the tip jack sockets complete with the nuts and lockwashers and assemble on to the panel in the holes that are in the labels. Make sure to

put the lockwashers and solder lugs underneath the tip jack socket nuts when you are screwing them on, and tighten these nuts well as they are likely to work loose unless you do so. A word of warning here—it is advisable to tighten the tip jack sockets from behind the front panel, and thereby avoid any danger of scratching the labels. If you wish you can hold the hexagonal-shaped heads on the front of the panels with a spanner, but do not use a pair of pliers. Tighten the

PARTS LIST D.C. MODEL

- 1—Metal case with lid.
- 2—socket labels.
- 1—knob.
- 1—N.P. brass stud with nut and washers for switch hole.
- 1—bakelite battery panel with clip.
- 1—50,000 ohm multiplier.
- 1—1,150 ohm wire wound resistor.
- 4—self-tapping screws
 - 1½ m.m. spaghetti.
 - 1—0/1 m.a. meter.
 - 1—control label.
- 12—tip jack sockets with nuts, lockwashers and solder lugs.
- 1—bakelite resistor panel with lugs.
- 1—10,000 ohm multiplier.
- 1—shunt.
- 1—leather handle with screws, washers, and lockwashers.
- 4—meter screws (on meter).
- 1—potentiometer with 3 washers.
- 2—bakelite tip jack socket insulating strips.
- 4—½ meg. multipliers.
- 1—14.8 ohm wire wound resistor.
- 1—950 cell.
- 18 SWG wire.
- Resin-cored solder.

Additional Parts

Required for A.C. Model

- 1—MCS1 1 m.a. rectifier with 6 B.A. screw.
- 1—switch.
- 1—.25 mfd. condenser.
- 1—round knob with indicating line.

nuts with a pair of pliers by all means, but not from the front panel.

When the tip jack sockets are assembled with the bakelite insulating strips underneath them, and the lockwashers and solder lugs underneath the nuts, you are ready to go on with the next piece of assembly. The main control label,

with the word, "Unikit" on it, should be held on with the potentiometer and the three insulating washers. The smaller washer fits in between the two larger. Take the small black knob that is supplied with the kit, and screw this on to the shaft of the potentiometer. Since the switch is not supplied with the DC kit, cover this hole with the nickel-plated brass stud supplied, which should be held on with the bolt and washer screwed in from the back.

Take the meter out of its carton, and you will find four screws loosely fitted into the meter on the four mounting holes. This meter is already adjusted so that all you have to do is to remove the four loose screws from the back of the meter, put the meter on the front of the panel, and the mounting holes should coincide with the holes in the metal case through which the mounting screws should go. First of all, put in the two screws on the left-hand side or the negative terminal side of the meter. Then take the panel which has the battery clip on it, put that on the right-hand side of the meter, and the two mounting screws will go through the holes in this panel into the meter. Then you can screw the four mounting screws tight, and you will have the meter and battery holder mounted.

Next comes the resistor panel, which is almost the final assembly. There is only one right way to mount this resistor panel. Take the panel, and you will notice that running all down the panel there are pairs of holes except at the very end, where there is one single hole by itself. This single hole is designed to hold the rectifier for the AC version. Place the panel over the meter terminals—first of all removing the loose nuts and lock-washers and solder lugs—so that this single rectifier hole is down at the bottom of the kit, very near the AC/DC switch. Refer to the back of panel photograph here, and you will see what is meant. When you have done this, put a washer over each of the meter terminals, followed by a solder lug, lock-

washer and finally a nut over each terminal. These will screw down tightly so that they hold the panel on firmly. Make sure that the lugs are pointing to each other for easy wiring. You will see what is meant by referring to the back of panel photograph.

WIRING

The next step in construction is the wiring of the instrument. This can best be done in stages, and the first stage is to wire all of the

resistors on to the main resistor panel which mounts on the meter.

Referring to the photograph and the drawing showing the wiring you will see that there are six resistors in moulded bakelite, these being the voltage multipliers. At the very top of the panel, farthest away from the potentiometer, solder on the four .25 megohm resistors. Make sure that your lugs are already tinned, and that the ends of

(Continued on page 9)

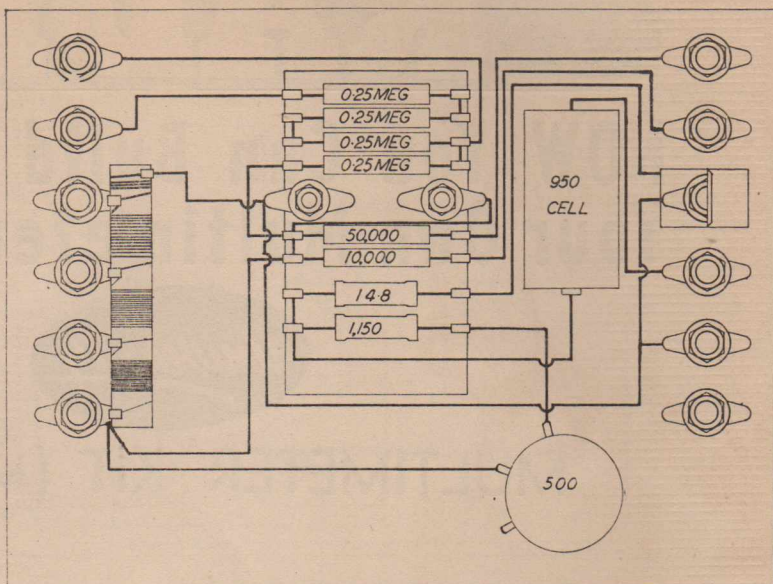

Picture diagram and photograph of the D.C. model.

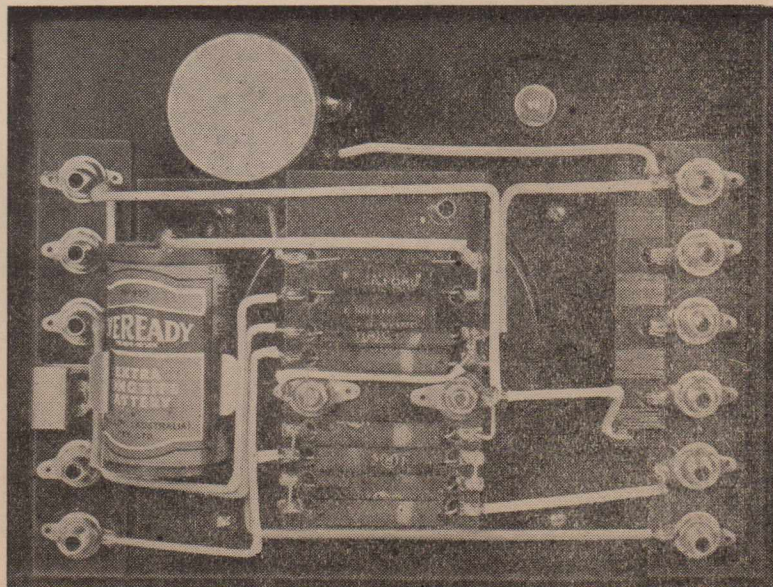

for **RepcO** **RADIO**

**NOW You Can Build
Your Own Multimeter With the**



MULTIMETER KIT (Model MKI)

IT'S HERE! A new release by Radio Equipment Pty. Ltd., and just what you have wanted for a long time . . . the **MULTIMETER KIT (UNI-KIT)** as illustrated.

It possesses all the parts necessary for the construction of an AC or AC-DC MULTIMETER, and its simplicity of construction is outstanding.

Special Features:

Unique circuit arrangement dispenses with the need for double circuit pin jacks (only one double circuit pin jack is used on the whole instrument); crackle finished case; etched panels; matched components; 4-in. square type meter with Multi-scale; overall dimensions of complete instrument—approx. 6-in. x 8-in. x 3-in.; leather carrying handle.

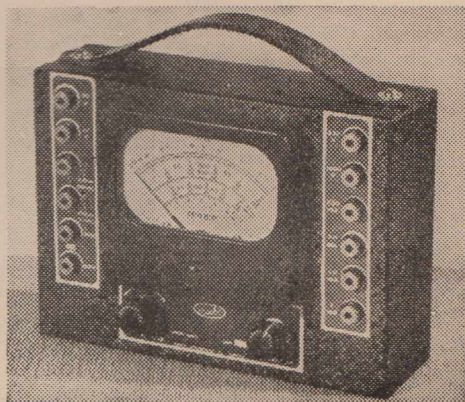

Wholesale Distributors in Victoria:

REPLACEMENT PARTS PTY. LTD.
(DIVISION OF REPCO LTD.)



618-640 ELIZABETH ST. MELB. C.1.

AND AT
HAMILTON-WARRNAMBOOL, VIC.

TELEPHONE: F0421 (23 Lines)

LAUNCESTON & BURNIE —
(Tas.)

MULTIMETER

(Continued)

the wires on the resistors are tinned so that soldering can be carried out quickly, thus applying the minimum heat to the resistor. Applying excessive heat to the end of the resistor may affect its accuracy, but if you solder quickly and make sure that the joints are clean, you will have no trouble. Immediately below the two meter terminals are two more resistors. In their order they are the 50,000-ohm resistor and then underneath it is the 10,000-ohm resistor. Immediately, below that again are two wire-wound resistors. One is a value of 14.8 ohms, and the other is a value of 1,150 ohms. Place these neatly with their wires straight, and then solder them on carefully. For the moment we are forgetting the AC instrument, so that completes the assembly and wiring of the resistors on to the main panel. Next, connect the resistors together where they have to be connected. For example, the .25 megohm resistors are connected in series. Refer to the circuit diagram here, as well as to the drawing showing the back of the panel wiring. You will find that the 14.8 ohm and 1,150 ohm resistors are connected together at one end. The 10,000-ohm and 50,000-ohm and one .25 meg. are all connected together at one end. The .25 meg. resistors are all then connected in series as shown on the drawing. Now, connect the solder lugs on the resistor panel to the various tip jacks and other parts of the circuit as shown on the back of panel drawing and the circuit diagram. This is quite easy to follow, and no detailed instructions are necessary here, except a warning that it is wise to tin the lugs first of all with a small amount of solder so that the actual wiring can be carried out effectively and neatly. When wiring, use the 18-gauge tinned copper wire which is supplied. Cut to suitable lengths, and cover with the Nylax or spaghetti tubing supplied. A hint that will

make your wiring appear neat is to stretch the full length of the 18-gauge tinned copper wire first of all.

You can do this by tying one end to a door knob or nail or putting it in a vice, and then pull the other end with a pair of pliers. You will find that the wire will stretch quite a few inches, and you will be left with a nice long length of perfectly straight wire. Cut up into convenient sizes, and then carry

out your wiring, making sure that all of your bends are made with a pair of pliers to get them neat.

Now, is the time for wiring in the milliampere shunt. You will find that one lug on the shunt has a red dot on it. Solder that lug directly on to the tip jack socket marked 250 milliamperes. The other lugs will solder directly on to the other milliampere tip jack sockets, except the extreme top end,

(Continued on page 30)

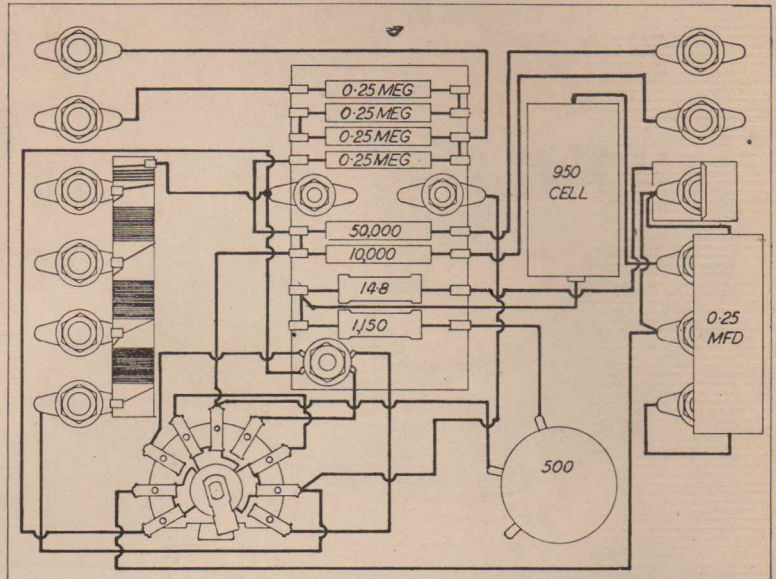

Picture diagram and photograph of the A.C./D.C. model.

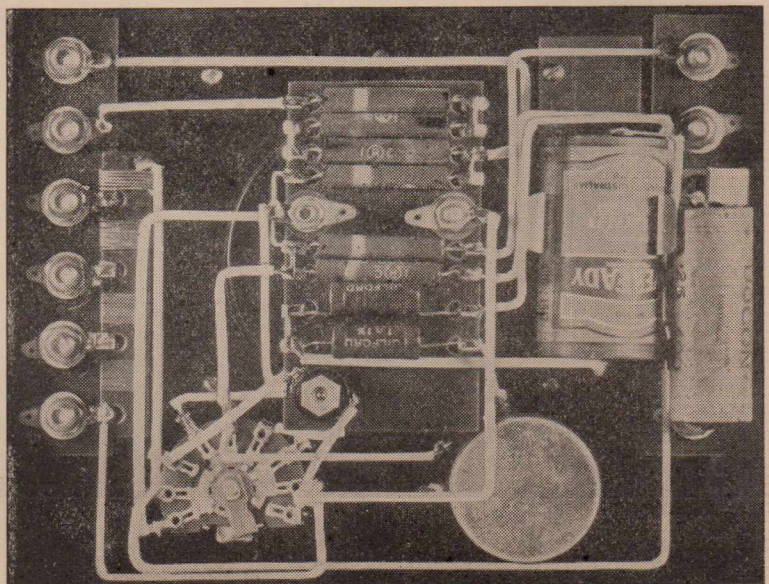

LOOP Aerial Portable COIL Kit...

42/-

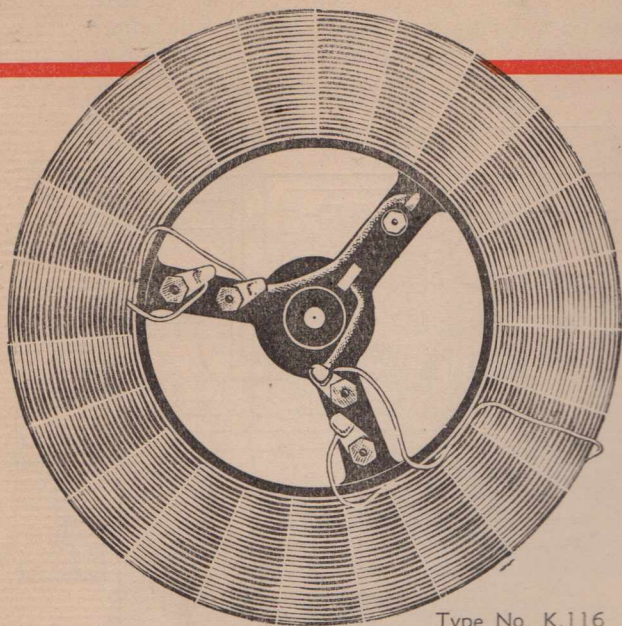

Type No. K.116

● This Special R.C.S. "LOOP AERIAL KIT" has been carefully engineered to give high performance with excellent stability, each component being designed to work efficiently in the complete kit, ensuring the elimination of alignment and tracking problems. This kit is prematched and tracked as a unit at the factory, on precision "Q" meters.



PERMATUNE
INTERMEDIATES
I.F. 162—
PERMEABILITY
tuned
I.F. 163—460 K.C.

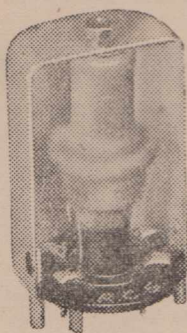

OSCILLATOR
COIL
TYPE E3.44

KIT comprises—

1—loop aerial coil, 2—permature intermediates, 1—oscillator coil, 1—padder and all are **GUARANTEED ONLY IF USED AS RECOMMENDED IN THE COMPLETED KIT.**

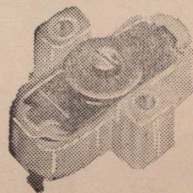

PADDER
TROLITUL BASE
TYPE P21.

● ORDER FROM YOUR USUAL RADIO RETAILER. NO DIRECT ORDERS ACCEPTED

R. C. S. RADIO PTY. LTD.

174 CANTERBURY ROAD, CANTERBURY

CRACKING THE OYSTER!

How to get going on the 166-170 Mc. Band

AFTER restoration of licences in January this year, many VK's made a mental reservation that 166-170 Mc/s might be handy for "short-haul" QSO's. In Sydney and Melbourne, pre-war 56 Mc/s enthusiasts lost no time in putting the new "Six-metre" band to work. With communication methods and equipment established there, the next band came in for attention, half-heartedly at first; but with increasing interest as preliminary obstacles were overcome. "One Sixty Six" proved to be a bit of a headache for a start—refractory receivers and uncertainty of lecher-line measurements pre-

sent hurdles for a few in "finding the band." Valves that functioned reasonably well at 112 Mc/s seemed stricken with paralysis at 166 Mc/s, both in transmitters and receivers. Aerials that were resonated carefully still didn't seem to turn the trick in pulling in or pepping signals clear across the city areas. But Sydney VK2's overcame these snags and now treat the band as a cherished possession. I believe that is now true also of Melbourne and Adelaide. It is evident to the few VHF enthusiasts in these cities that the 166 Mc/s band provides an excellent cross-city medium for relatively QRM-free communication provided something other than that willing horse, the "squegger" receiver, is employed.

tween two points is all required. It is not suitable for net working, as those who used certain armoured vehicle gear during the recent war well know. Experienced "hams" with pre-war VHF knowledge could have told the designer of that gear what would happen with
(Continued on page 12)

BY

DON B. KNOCK

VK2NO*

mented hurdles for a few in "finding the band." Valves that functioned reasonably well at 112 Mc/s seemed stricken with paralysis at 166 Mc/s, both in transmitters and receivers. Aerials that were resonated carefully still didn't seem to turn the trick in pulling in or pepping signals clear across the city areas. But Sydney VK2's overcame these snags and now treat the band as a cherished possession. I believe that is now true also of Melbourne and Adelaide. It is evident to the few VHF enthusiasts in these cities that the 166 Mc/s band provides an excellent cross-city medium for relatively QRM-free communication provided something other than that willing horse, the "squegger" receiver, is employed.

The super-regen. is a useful gadget, but minus an aerial coupling valve it can raise hob in a locality where a few stations are on the

* Experimental Radio Equipment Dept., Philips Electrical Industries of Australia Pty. Ltd.

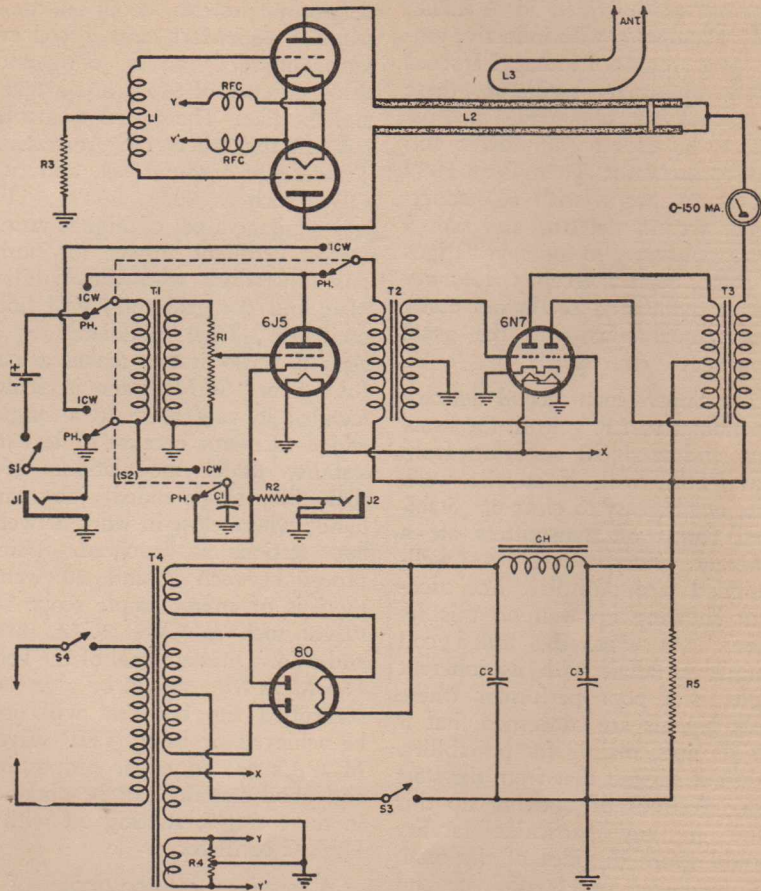

- R₁—500,000 ohm pot.
- R₂—1500 ohm, 1 w. res.
- R₃—5000 ohm, 10 w. wire-wound res.
- R₄—75 to 100 ohm, 1 w., c.t. res.
- R₅—25,000 ohm, 50 w. wire-wound res.
- C₁—10 μfd., 50 v. elec. cond.
- C₂, C₃—2 μfd., 600 v. cond.
- J₁—Single circuit midget jack
- J₂—Normally closed midget jack
- S₁, S₃, S₄—S.p.s.t. toggle sw.
- S₂—4-pole, d.t. rotary sw.

- T₁—Single button mike-to-grid trans.
- T₂—Class B driver trans. (3 to 1 stepdown ratio)
- T₃—Modulation trans. (10,000 ohm pri. to 5000, 6500, 8000 ohm load)
- T₄—Power trans., 500-0-500 v. @ 175 ma. 6.3 v. @ 3 amps, 6.3 v. @ 6 amps, 5 v. @ 2 amps.
- CH—15 hy, 175 ma. filter choke
- L₁, L₂, L₃—See text

Fig. 2. Circuit for an effective p.p. triode grid-coil plate-line transmitter for 166 megacycles with Class B modulation.

(Continued)

a squadron of tanks trying to use the "B" sender at once! Thus, non-radiating receivers are desirable, again a fair measure of selectivity is, as at lower frequencies, just as important. Three stations have tackled the problem here with good results. VK's 2WJ and 2LZ (60 miles from Sydney) both use the Jones Resistance I.F. Superhets and find that the 954 performs very well in the arrangement. VK2AZ, however, tackled the superhet from another angle. He made a receiver on the lines of the Super-regen-Superhet as described in A.R.R.L. 1946 Handbook, with inductive tuning, plus an extra I.F. stage! Instead of the 6J6 mixer/oscillator (these valves are not obtainable in Australia), he uses a 955 mixer and HY615 oscillator. There is an 1852 I.F. at 25 Mc/s, with 6J5 super-regen. second detector and 6V6G audio. Contrary to the expectations of some, such a receiver does *not* render modulated oscillators easily understandable as with the usual "squegger" receiver.

The Super-regen second detector contributes to I.F. gain in the usual way, and a signal suffering from heavy F.M. will, if on the weak side, not be easy to clear up. Stabilised forms of transmitters are a different story—even a well-designed push-pull-plate line oscillator showing up well on this receiver. As ever, the tuned coil transceiver affair with its inherent faults is a poor performer where weak signals are concerned, but it has its uses, mainly for portability. I do not suggest that from the start those desirous of opening up this band in any particular locality should spurn the idea of the mod. osc. squegger variety of gear and attempt more advanced receivers. If numbers of active stations are limited, much can be learned with such equipment, and its sheer simplicity is in itself quite fascinating.

COST A FACTOR

Unless the experimenter concerned is a rabid VHF man, he is not likely to lay out much cash at this stage, but a VHF triode or two

do not involve heavy expense. Such valves can be used also in push-pull oscillators at around 20 watts with excellent results. If you are one of the lucky fellows who caught things like 15E's in mid-air as they fell from Service trees, you possess, of course, an immediate 100-watt answer to the problem! Whichever way you look at it, the usual run of transmitting valves in unsuitable for 166 mc/s if you intend to use transmitters around the 100-watt mark. And don't get the idea that power doesn't count there—it does.

The ubiquitous 807, a willing performer to around 100 Mc/s, definitely protests about ill-treatment at 166 Mc/s, and if you are tetrode-minded you are obliged to think in terms of 815's, 832's, 829's and the like. The 815 is available, but not the others (in Australia). Triodes are a sound bet, and two valves such as 800's, 834's, 35T's and similar valves of higher rating are an excellent answer for push-pull operation, with the familiar plate and (or grid coil) grid lines oscillator. This, modulated by a class B audio system makes a useful rig for 166 Mc/s and is recommended in preference to a single-ended oscillator because of less instability under modulation. Not that the single-ended job isn't handy where close-in work between two stations is involved. Using power between 2 and 20 watts, there is of course ample scope for valves such as CV6, 2C22, 9072 and 6C4. Ultimate goal of the keen 166 Mc/s ham should be a crystal-controlled rig, but that will only be achieved by using VHF valves. MOPA's are an easier proposition and good stability can be obtained in three stages, starting off with a High-C oscillator.

A receiver can be more of a costly item than the transmitter;

BATTERY-OPERATED FERROTUNER

We hope to be able to describe
the above receiver in next
month's issue. Order now!

should you decide upon a superhet with two R.F. stages, mixer, and half a dozen broad-band I.F. amplifiers; but my contention is that such a receiver may not be considered worth the time and trouble, to say nothing of the expense, for use on a yet almost unoccupied band. There are other angles, including the resistance I.F. autodyne and Super-regen-Superhets both a goodly step from the squegger/modulated oscillator combination, but these will come into their own later. To make a start on the band, therefore, it is logical to use the simplest and least expensive gear.

SIMPLE SUPER-REG. RECEIVER

Fig. 1 is a circuit diagram of a self-quenching type of receiver similar to one in use for the time being at VK2NO. It gives excellent results within the capabilities of such receivers and is sensitive enough to respond to very weak signals. The legend of parts shows the values of resistors, etc., but some description of L3, L4 and C4 is called for. Quite a small capacity is all needed for the tuning condenser C4 (shown as 6 pfd) and here the ham will need to use his ingenuity. The condenser can easily be made up from a good grade of midget variable by spacing one rotor and one stator about one-eighth of an inch apart. If you rebuild a "moulded mud" type—albeit with a good bearing, etc., replace the poor insulating material by Polystyrene or Perspex. If you have been lucky enough to acquire a butterfly-type midget, as seen in many Service VHF receivers, you have the immediate answer.

One complete rotor and four stators will be suitable. C4 is used with stator and rotor both "hot," so is insulated from the chassis. Coil L3 consists of three turns of wire $\frac{1}{2}$ -inch in diameter and spaced out to occupy a space of 1 inch. Any gauge of wire stiff enough to be self-supporting will do, and the coil is soldered across the condenser stator and rotor by the shortest possible path. RFC3 is a VHF choke made by winding 25 turns of 20 enamelled copper wire on a

pencil and slipping the resultant coil off. RFC4 is important and is a multi-section RF choke of about 80MH. An RCS type 85 is just the thing. Object of this, with its filter C7, C8, is to keep the quench voltage from overloading the audio system. Adjustment of the regen. control R5 should put the detector into the super-regen condition with a *quiet*, not a noisy hiss level. The by-pass C6 across the detector heater is important and if there is any failure to oscillate, a useful tip is to include a VHF choke in series with the cathode to earth. The aerial coupling coil L4 should be variable in relation to L3 for best results as correct aerial loading can make all the difference between R9 and inaudibility. Method of doing it depends on individual ideas. My own receiver has two turns of 18 copper 1/2-inch diameter for L4, arranged to pivot on a strip of Polystyrene, adjacent to L3.

PUSH-PULL PLATE LINES TRANSMITTER

In the circuit of Fig. 2 is a suggestion for a fairly stable oscillator/transmitter for this band wherein many types of valves can be applied. Be warned, however, that you will be disappointed if you try to make out with standard based triodes, such as 210's, etc. VHF valves such as 800's or 834's are the answer, and if you have any "specials" so much the better. Two 15E's in the arrangement shown will easily handle 100 watts, so will 8025's—to say nothing of "micro-pups." The latter are unusable, however, without a cooling blast of 30 cu. feet of air per minute, owing to the filament requirements of 8 volts at 8 amperes per valve. But if you have a blower-fan—why not?

The filament chokes RFC are made of about 30 turns each of 14 enamelled copper wire 1/2-inch diameter, and self-supporting. Grid coil L1 has 4 turns of wire 3/8-inch diameter and has the grid clips soldered directly to the ends for clipping to the valves. The coil is spaced over a length of about two inches, which means that it is more of a wire spiral than a coil. Ex-

perimentation is needed here. The switching arrangements for this suggested transmitter show a two-position switch for phone and ICW. This is an excellent scheme—to include ICW for calling where communication may be poor on speech in difficult locations. J1 is for a carbon microphone and J2 for the noise key. The microphone transformer T1 is used to provide feedback in the first audio valve as an audio oscillator. Gain in speech and ICW is controlled by R1. The plate lines L2 consist of two 1/2-inch diameter copper tubes 12 inches long and spaced 1/2-inch apart. They are supported on Polystyrene blocks and provided with a shorting bar for frequency adjustment. This bar should be well-made and is worth constructing solidly from brass or

copper in two sections, plus a clamping screw. Much more can be written about even introductory gear for 166 Mc/s, involving aerial systems for best results, and frequency checking, but lack of space decrees that I do this in future issues. For the time being, the diagrams and brief references to the more important features of the simple equipment described will suffice to encourage those to whom 166 Mc/s is yet an "unopened oyster" to get in there and make a start. It's not so boring as you may think down there—sentiments echoed in Sydney and points West by VK's 2WJ, 2AZ, 2ABZ, 2AGL, 2KI, 2AFO, 2LZ, 2ADK, 2HK, 2YE and 2NO. There will be others.

—D.B.K.

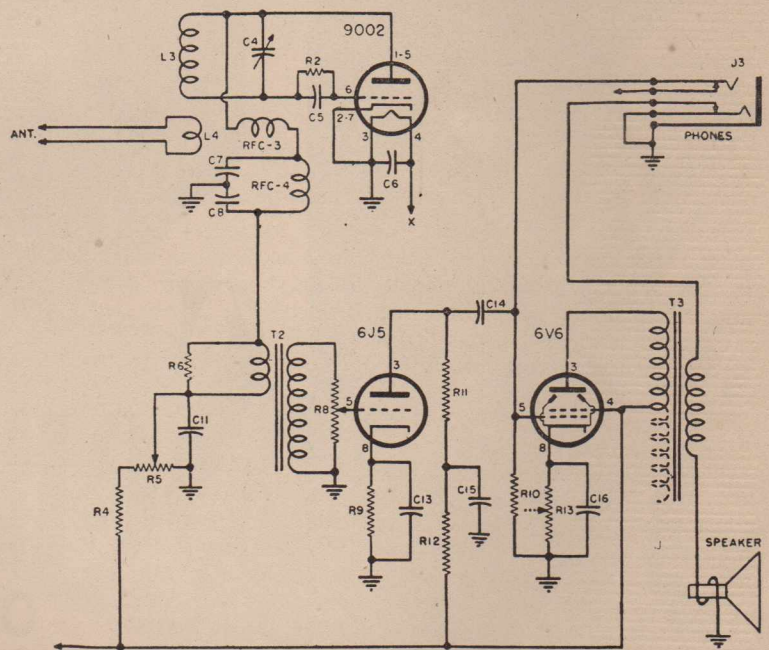

- R₁—10 meg., 1/4 w. res.
- R₂—250,000 ohm, 1 w. res.
- R₃—50,000 ohm, wire-wound pot.
- R₄—50,000 ohm, 1/2 w. res.
- R₅—500,000 ohm pot.
- R₆—2000 ohm, 1/2 w. res.
- R₁₀—500,000 ohm, 1/2 w. res.
- R₁₁—100,000 ohm, 1/2 w. res.
- R₁₂—25,000 ohm, 1/2 w. res.
- R₁₃—500 ohm, 10 w. adjustable wire-wound res.
- C₁—6 μfd. trimmer
- C₂—50 μfd. ceramic cond.
- C₃—300 μfd. mica cond.

- C₇—0.05 μfd. mica cond.
- C₈—0.01 μfd. mica cond.
- C₁₁—25 μfd., 400 v. paper cond.
- C₁₃, C₁₆—10 μfd., 25 v. elec. cond.
- C₁₄—0.3 μfd., 400 v. paper cond.
- C₁₅—10 μfd., 450 v. elec. cond.
- L₃, L₄—See text

- T₁—trans., mic. and single plate to grid
- T₂—Universal output p.p. plate-to-voice coil
- RFC₃—See text
- RFC₄—80 mh., r.f. choke
- J₂—2 pole, circuit opening jack

Fig. 1. A super-regen for 166 megas. A 955 acorn may be used in place of the 9002.



Sentinels OF BETTER RADIO

Whether you build radios by the thousand, service them by the hundred, or make sets as a hobby, Better Radio is very much your business. As a manufacturer, you are helping yourself to goodwill by fitting Philips valves in your sets. As a service man with an eye on the future, you find that Philips valves are your finest possible introductions to satisfied customers. If you are a "ham," you need Philips valves just as much as the factory executive or the dealer just around the corner.

There is a Philips Valve for every socket of any receiver.



PHILIPS VALVES

PHILIPS ELECTRICAL INDUSTRIES OF AUSTRALIA PTY. LTD.
SYDNEY — MELBOURNE — ADELAIDE — PERTH — BRISBANE

Why you should . . .

BUILD YOURSELF AN "F.F.R." AMPLIFIER

HAVING read all that has already appeared about this amplifier, you will undoubtedly start to wonder why we are so emphatic that every one of our readers who can afford to do so should make a point of building up one of these outfits.

We look upon it as the only true foundation on which to build up a radio gramophone or a powerful receiver. When you have a "Full-frequency Range" amplifier you know that at least you have a perfect amplifier. At the moment you may find it hard to get input of worthy quality, or a speaker capable of handling the fine output, but you will have the assurance that no matter how improved records may come along, better pick-ups to operate with them or high fidelity speakers, you will at least know that your amplifier is faultless and capable of handling anything you can give it.

FOR USE WITH F.M.

If high-fidelity transmissions are introduced with frequency modulated transmitters, you will be happy in the knowledge that your amplifier will be waiting, and will be capable of giving high-fidelity reproduction up to the standards laid down by the F.C.C. in America; in fact, with a considerable margin of performance to spare. All you will need will be the tuner and discriminator unit to go ahead of the amplifier.

Improvements in recordings, pick-ups and speakers are bound to come about in the course of time, but your amplifier will always be up-to-the-minute because there is no room for improvement.

For the moment performance of the amplifier is limited by the limitations of input and output, but even so it is still capable of giving exquisite music from good recordings and broadcasts. Many people believe that their present amplifiers are so good that they are good

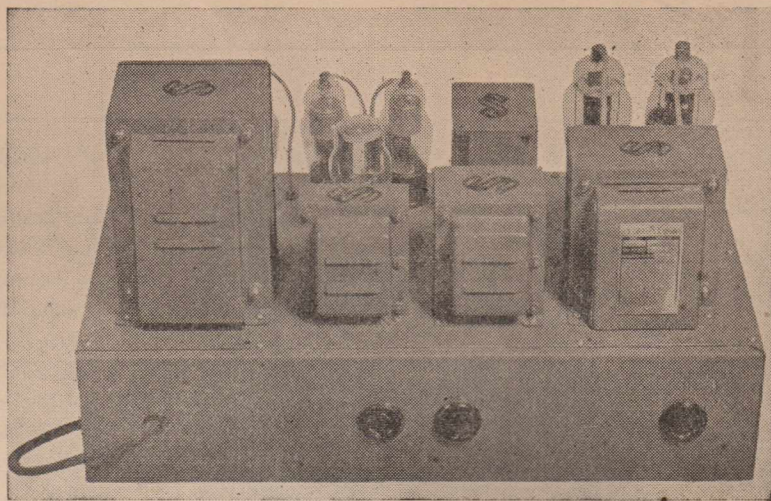

A photograph of the original "Full Frequency Range" amplifier.

enough to handle the quality available from ordinary records and broadcasts. This may be fairly true of the actual frequency response, but there are many other vital factors which must be considered, transient response, several types of distortion, linearity and the matter of phase in the output.

With all these so well covered in the "Full-frequency Range" amplifier, it is not surprising that the performance, judged by the ear under normal listening conditions, comes right up to the expectations based on the laboratory performance.

A WARNING

Many of our readers are adept at the practice of taking a given circuit as a basis on which to work, then modifying it to suit the components they have on hand, fiddling around as they go ahead with the building up of the job, probably finishing up with entirely different valve types and so on. Often enough this works out quite well, but is almost certain to be a complete failure with this particular amplifier. Under unfavourable circumstances, with plenty of para-

sitics and 730 volts romping around inside the 807's and some error in the biasing, as a typical example, and you have the perfect set-up for a heart-break. In fact, it would not be beyond expectations for the 807's to actually explode. On the other hand, if the amplifier is built up exactly to specifications with the special components which have been prepared for it, you are assured, not only of a completely satisfactory amplifier as regards performance but one which should give years of care-free service, in spite of the high voltages employed.

With many high-powered amplifiers the coupling condensers are kept constantly under the full strain of the high-tension, but in this particular design this matter has been taken care of by the use of the twin power transformer.

The high tension voltage of 730 is kept to the plate circuit of the output valves only, and is not fed back to the driver stages at all. The driver stages are all fed from the auxiliary high tension of only 330 volts, so that they cannot be subjected to overload. This isolation of the main high tension vol-

(Continued on page 17)

KKI

THIS IS THE FAMOUS FERROTUNE FOUNDATION KIT

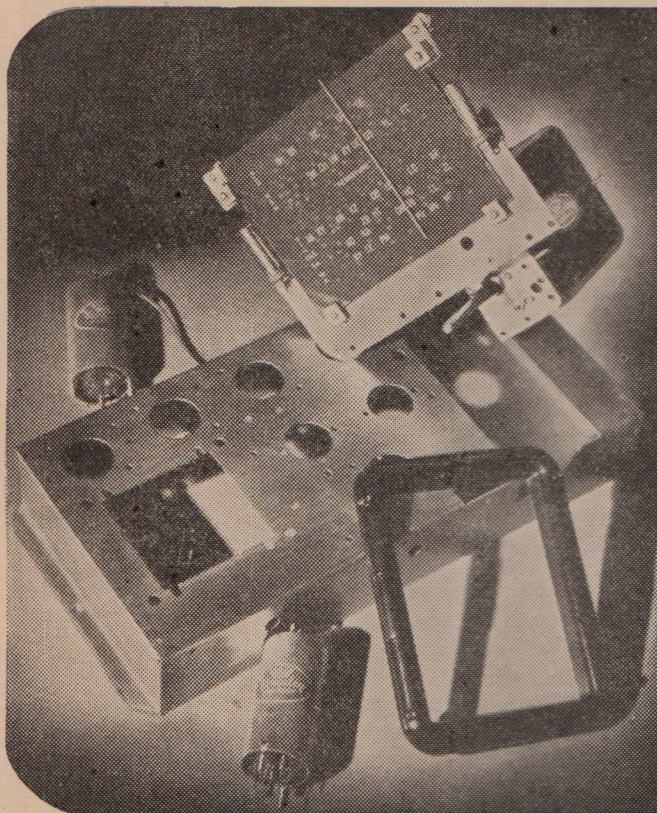

KINGSLEY RADIO brings all amateur set-builders a FOUNDATION KIT that makes any predecessors completely out-of-date. The FERROTUNE FOUNDATION KIT is based on the revolutionary IRON-CORE TUNING which KINGSLEY developed during the war years.

FERROTUNE brings you greater clarity of reception, faultless tuning of every broadcast frequency, increased coil I.F. gain and selectivity. Included in the FERROTUNE FOUNDATION KIT is . . .

1. The outstanding FERROTUNE ferromagnetic gangless tuning unit—it covers the broadcast band and includes tuning mechanism, straight line dial, padding and trimming, etc. It does not need further alignment.
2. Cadmium-plated steel chassis.
3. Two PERMACLAD I.F.'s which have exceptionally high "Q" ratings.
4. Complete attractive plastic escutcheon with glass window.

**OBTAINABLE FROM
AUTHORISED KINGSLEY DISTRIBUTORS**

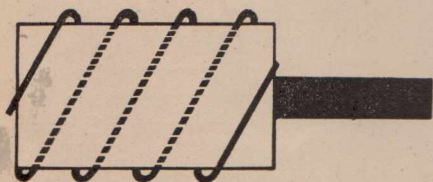

Ask your radio dealer for

F E R R O T U N E
FERRO-MAGNETIC IRON-CORE COILS, I.F.'s AND,
GANGLASS TUNING UNITS



KINGSLEY RADIO

K I N G S L E Y R A D I O P T Y . L T D .

380 St. Kilda Road, Melbourne, Victoria . Phones: MX 1159, MX 3653

AMPLIFIER

(Continued)

tage is a definite step in the right direction for long and trouble-free service.

Speaking of the high tension reminds us to mention that the caps of the 807's are the plates, and the plates are at full high tension in regard to the base, so the utmost care must be taken to see that the fingers do not come in contact with these caps. It is quite worth while considering the fitting of rubber spark plug covers over the caps of the 807's or wrapping them up in some way so that they cannot be touched readily. Another wise move is to fit the amplifier with one of the "meat-safe" type amplifier covers, as shown in the photographs. With the proper type of case, a cover over the top and a plate across the bottom the outfit becomes quite shock-proof, as it should be.

USING THE AMPLIFIER

The amplifier can be fed by input from a suitable pick-up. If one of the crystal type is used it will be found that the pick-up will give ample input to give you full output when the volume control is fully advanced.

There is nearly enough gain with many types of magnetic pick-ups, but if you want to use one of the low-output types, such as the moving coil type you will need to arrange a suitable pre-amplifier, with compensation if necessary.

Input can be had from a suitable tuner and detector unit, too. One preferred type is a superhet tuner, with r.f. stage, converter, then a single i.f. transformer of wide-band characteristics, feeding into an infinite impedance type detector. With this type of tuner, especially if a tertiary winding is used on the i.f. transformer, it is possible to get sufficient selectivity to separate the metropolitan stations, yet obtain truly amazing fidelity. It is surprising how improved some of the transmissions are these days, too. We hadn't realised it until we started to experiment with this amplifier.

Another tuner which is suitable consists of one or two stages of t.r.f. with an infinite impedance detector.

The matter of speaker equipment is a bit of a problem, but there are a couple of possibilities.

To handle the full 45 watts of power you will need at least four 12-inch auditorium type speakers in parallel, but with some considerable handling of the volume control it is still possible to use the amplifier for home use with a single 12-inch speaker and some restraint. Another way is to use twin speakers, such as a G12 and an 8/42 in parallel, with the G12 handling the lows and the 8/42 the highs. In order to achieve this calls for the use of a discriminating network, and these are being made available. Operated in this way, the two speakers should handle about 20 watts between them, so you won't need to exercise quite so much restraint.

But the ideal way for using the amplifier for home use is to fit actual damping resistors across the

voice coil or coils. This cuts down your power proportionately, but gives you many of the advantages usually claimed for inverse feedback, but without its drawbacks.

Used in this way with a single speaker and dissipating three-quarters of the power output in a suitable resistor, you can still have about ten watts to drive your speaker, and the quality is then truly magnificent.

Of course when damping the speaker in this way, it is necessary to re-arrange your matching of loads.

FOR PUBLIC WORK

The amplifier is so outstanding in its performance that it can be strongly recommended for use in halls, as a dance band amplifier, for a talkie installation or as a general demonstration amplifier. The performance is so far beyond that obtained with most existing talkie installations that there need be no hesitation in offering to install this amplifier alongside any other one for a comparison of performance.

SAVE MONEY WITH A SUBSCRIPTION!



Order Yours To-Day

Make sure you get every issue as soon as it is published. Place an order with your newsagent or send direct to us for a subscription.

**IT SAVES YOU TIME!
IT SAVES YOU MONEY!**

We guarantee that every subscriber has his copy posted the same day it comes off the press.

RATES		
* 6 issues	5/3	
* 12 issues	10/6	
* 24 issues	20/-	
POST FREE		

Enclosed please find remittance for 10/6 in payment for an annual subscription to the "Australasian Radio World," commencing with the issue.

NAME.....
STREET and NUMBER.....
CITY..... STATE.....

AUSTRALASIAN RADIO WORLD

Balcombe Street
Mornington

Next Aegis Success,

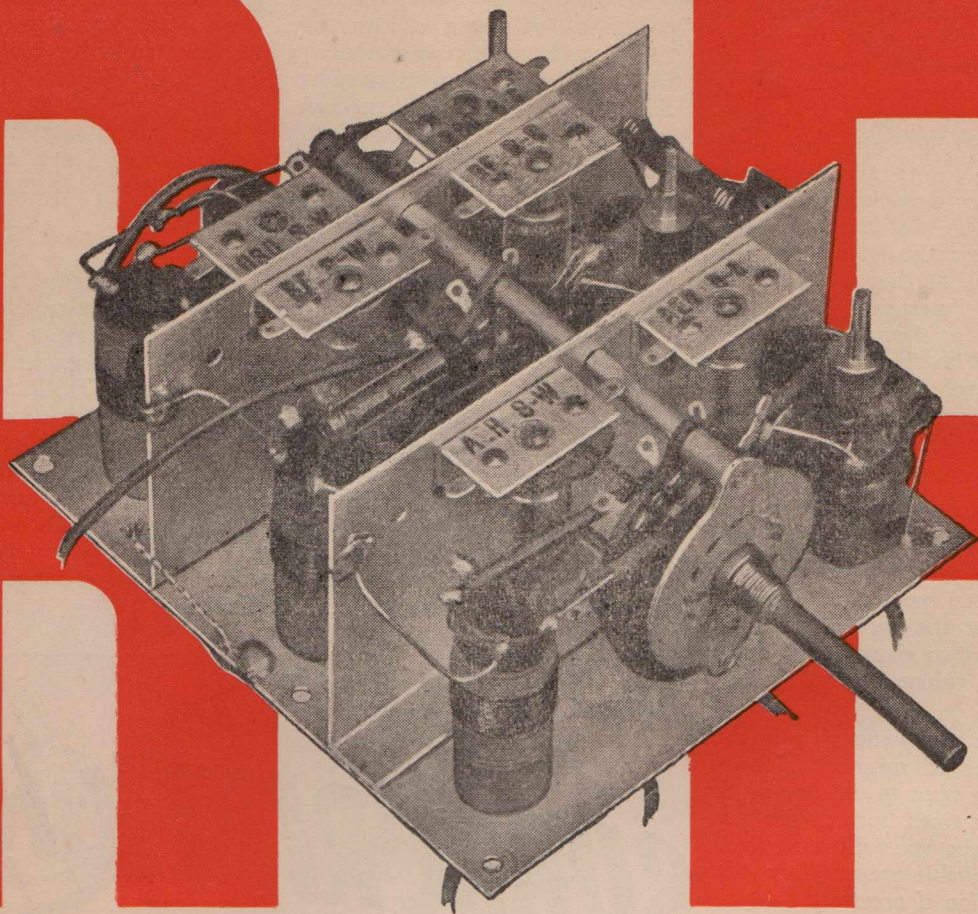

ATTRACTIVE DISCOUNT TO
LICENSED AMATEURS FROM
AEGIS DISTRIBUTORS IN
ALL STATES

KIT

AEGIS

MANUFACTURING COMPANY PTY. LTD.

208 LT. LONSDALE ST., MELB.

NOW AVAILABLE! This outstanding addition to the well-known Aegis range—a three stage R.F. Dual Wave Assembly. Look at these features—Permeability Iron-cored both B/C and S/W Coils, 7-22 meg. S/W, 550-1600 KC B/C band. Special cadmium sub-chassis. A.W.A. Air Trimmers. Fixed Mica B/C and S/W Padders fitted. All assemblies pre-aligned on special tester before leaving factory. All coils treated with trolitul and lo-loss wax. A.V.C. resistors and condensers, decoupling resistor in R.F. stage. Easy and comprehensive colour code and ligning instruction sheet supplied.

RETAIL PRICE 140/-

Full-Frequency Range Amplifier

HAVING agreed with us that you should build up one of these amplifiers, the first step is to get the kit of parts together, and so we must start by repeating the warnings given elsewhere that it is advisable to follow the original amplifier as closely as possible, and use the special components which have been developed for the amplifier.

For example, you may have a Ferranti AF5CC on hand, which is a mighty fine audio transformer. But it will not take the place of the Red-line AR2 in this particular amplifier. To use the AF5CC would completely alter the gain and performance of the amplifier. And so it goes. If you have a filter choke on hand and use it in this amplifier, there is no way for us to know whether it is exactly the same resistance as the one specified. If you can check it yourself, well and good, otherwise you will risk getting incorrect voltages. Even if the resistance is the same it is possible that its effect on the output of the rectifier will be different, especially in the case of the choke in the main high tension. Still another factor comes into this choke; as it takes the pulsating current from the rectifier the laminations will tend to hum unless special precautions have been taken with its mechanical construction. So you will see that even if ordinary components appear to be suitable, the only sure way of getting certain satisfaction is to use the special components which have been made available. There are only five of these special components, all the rest being just stock lines, readily available, and if you have suitable parts on hand they can be used without any need for worry.

THE LAYOUT

The layout shown has been chosen as a compromise between mechanical and electrical considerations. It would be possible to have

a possibly more efficient layout from an electrical point of view by keeping all the power equipment down to one end, keeping the output transformer down towards this end, and then running back step by step to the input, out in the clear at the other end. Although this would be ideal in some ways, it would introduce trouble through all the weighty components being bunched at one end of the base. The layout shown gives a nice balance of weighting and is O.K. electrically if you make sure you do what you can to keep the input circuit components clear of the rectifier sockets.

FILAMENT WIRING

The wiring of the heaters of the 807's needs to be kept well clear of the audio amplifier valves and so should not be run directly to the power transformer, but rather in a roundabout way, via the back of the base. This can be seen in the

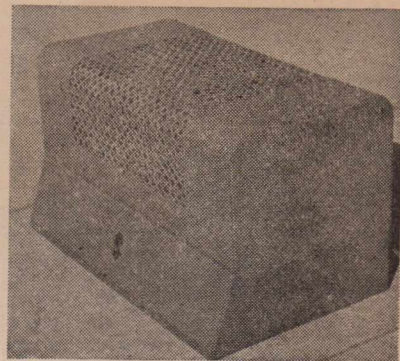

To finish off the amplifier, one of these "meat-safe" style covers can be fitted.

photographs of the original, and was one of the minor points which we proved to be of practical importance by actually building up a chassis with the wiring running down among the 6J7's and then having to re-wire in order to re-

(Continued on page 21)

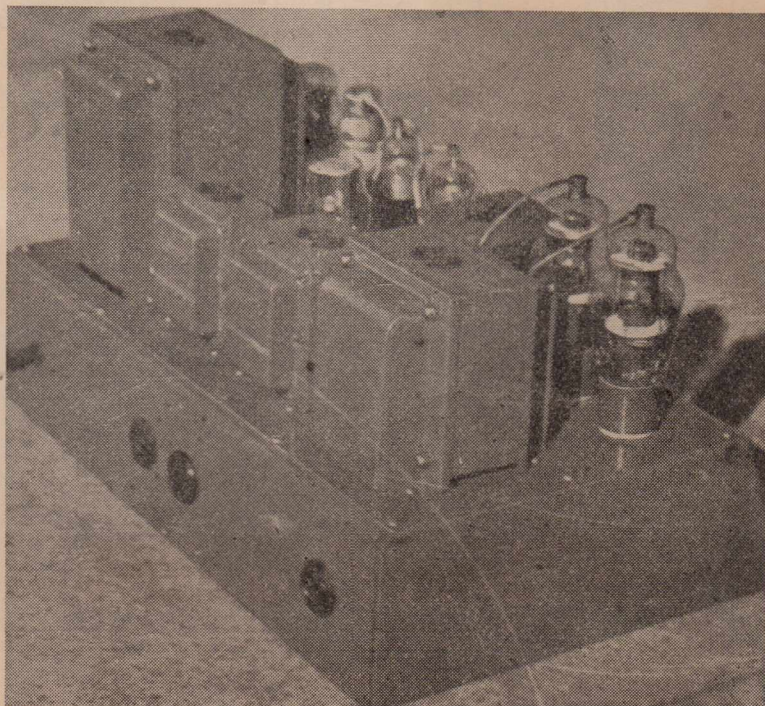

F.F.R. AMPLIFIER
(Continued)

move the last trace of hum.

EARTHING THE HEATERS

Some care is needed in the matter of earthing the heater circuits. The

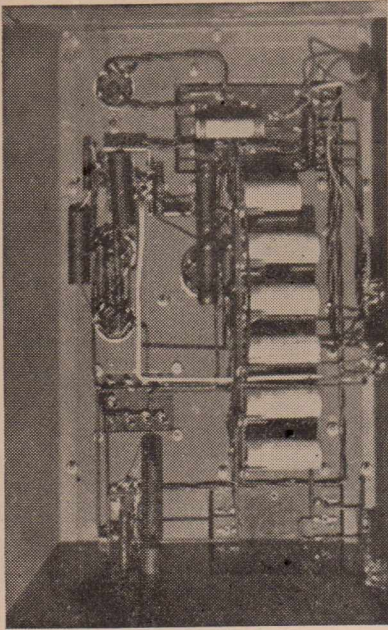

heater circuit of the 6J7G's is earthed through a 50-ohm centre-tapped resistor mounted right at the power transformer terminal board.

On the other hand, the heater circuit of the 807's is "earthed" by making a direct connection from one side of the heater, right at the socket, across to the centre-tap of the cathode stopper resistor. This keeps the heaters above earth at a potential close to that of the cathodes.

Another precaution which should be carefully followed in this amplifier, even if previous experience has shown that it is not essential with ordinary amplifiers, is in regard to the centre tapping of the 6J7G heater circuit.

A 50-ohm centre-tapped resistor should be used and it should be mounted right at the terminal board of the power transformer, the centre-tap then being "earthed" to a soldering lug mounted under one of the mounting screws of the power transformer. This earthing lug should be used exclusively for this centre-tapping.

Special Component 1
POWER TRANSFORMER

RED LINE, TYPE No. 5176
(Sub-panel Wiring)

Primary: 200-230-240 V. 50 c.p.s.
High Tension (1): 730/730 V. at 200 mA.
High Tension (2): 330/330 V. at 100 mA.
Rectifier (1): 5V. 3A.
Rectifier (2): 5V. 2A.
Heater (807): 6.3V. 2A.
Heater (Pre-Amp.): 6.3V. 3.6A.
Base Area: 5 $\frac{1}{2}$ " by 4 $\frac{1}{2}$ ".
Cut-out: 3" by 4 $\frac{3}{4}$ ".
Height: 6".
Weight: 15 $\frac{1}{2}$ lbs.
Price: £7/10/-.

This transformer was designed primarily to deliver all the voltages for the Full Frequency Range Amplifier, and fulfill regulation requirements within the strict limits decided upon.

The core is built of low W/loss per lb. electrical sheet, so that it is operated well below saturation at full load. One transformer was selected in preference to several, with a view to consumption economy and weight, as well as the load angle reducing effect of the heaters being useful in obtaining superior regulation of the high voltage after rectification.

The selection of a sufficiently large core, of high quality steel, allows a high turns per volt ratio at full load to reduce the quadrature current in this transformer to a minimum.

THE LINE VOLTAGE
The power transformer is fitted
(Continued on page 22)

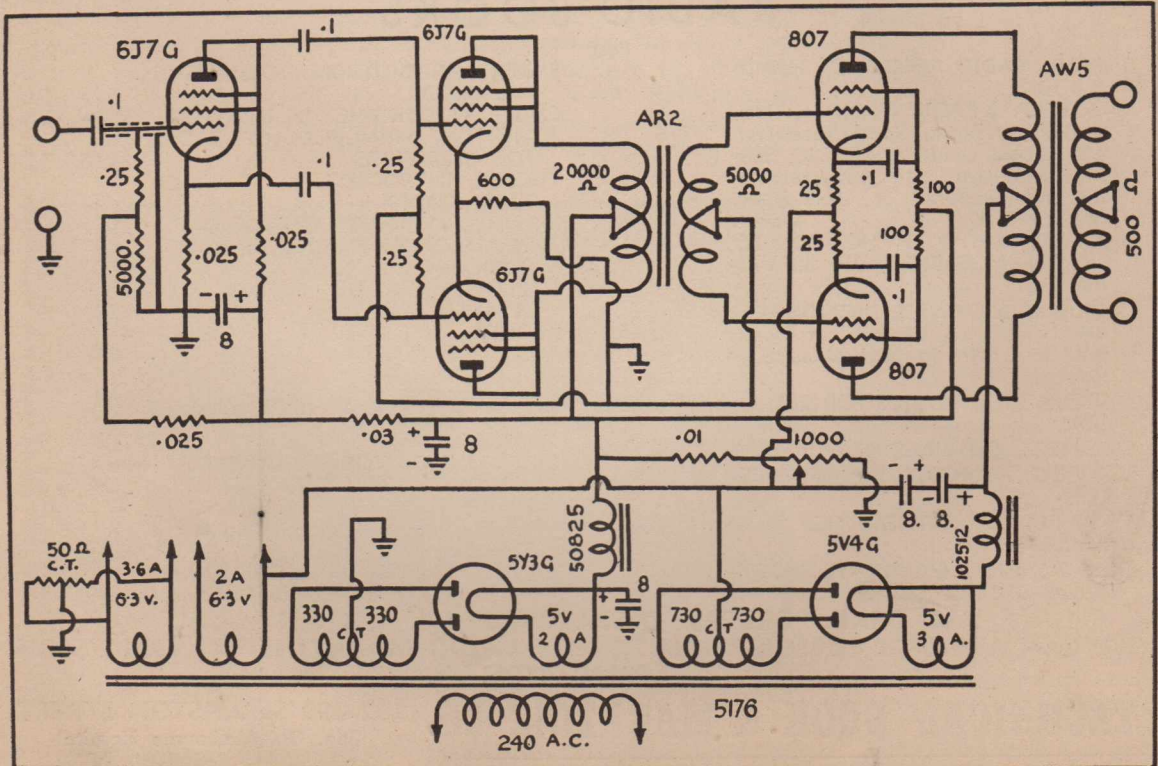

F.F.R. AMPLIFIER (Continued)

with a tapped primary and it is well worth while to find out exactly what the line voltage happens to be and use the right tapping. This will ensure that the high tension and heater voltages will be correct throughout the whole job.

It is seldom that the line voltages will be found to be as rated, the suburban line voltages being anything from 190 to 260 volts when rated at 240 volts.

The checking of the line voltage is just another reason why it is so highly desirable to borrow a meter to check voltages if you do not already have one available.

INPUT SHIELDING

The most likely source of hum trouble and hash is in regard to the input circuit, the tubular condenser there, the volume control, if fitted to the base, and the actual lead to the grid of the first 6J7G. It becomes even more important when using the 6SJ7GT valves which have the grid terminal down on the socket amongst the others.

When experimenting with one of these amplifiers we found, in one case, that a solid amount of hash in the output could be entirely eliminated by wrapping the .1 mfd. condenser in a piece of 18 gauge aluminium, mounted under a screw. With a normal receiver you wouldn't expect a piece of aluminium to be effective as a shield at audio frequencies, but it just shows how careful you have to be when you have an audio amplifier with such an extended frequency range as this one.

EARTHING PRECAUTIONS

With a normal amplifier the matter of earthing is not of much importance and it is usual to earth all condensers and resistors to lugs under the handiest screw. But when you are handling a wider band of frequencies such a rough and ready method is not permissible. It is essential to group the earthing to avoid the effects of eddy currents in the metal of the base, which can reach considerable proportions at certain frequencies.

Special Component 2 INPUT FILTER CHOKE

RED LINE. TYPE No. 102512

Max. Current: 250 mA.

Primary Inductance at 200 mA: 10 Henries.

Primary Inductance at 100 mA: 14 Henries.

Primary Inductance at 50 mA: 15 Henries.

D.C. Resistance: 100 Ohms.

Base Size: 3" x 3 3/4".

Height: 3 3/4".

Weight: 5 1/2 lbs.

Price: £1/14/-.

This unit is specifically designed for choke-input filter systems where large alternating voltages appear across the initial choke. While retaining compact form, it has ample smoothing inductance with 150 mA. direct current. Used in the Full Frequency Range Amplifier, the inductance change is less than one henry between stand-by and full output current conditions.

Mounting with the gap vertical minimises chassis induction currents, and rugged, cold-drawn covers, with six clamping bolts, resist mechanical vibration caused by magnetic repulsion at the gap.

To describe the grouping in detail would be a rather long-winded story, but we have shown the grouping on the picture diagram. We strongly advise every builder to watch the picture diagram carefully

RADIO BOOKS

	Post		Post
BABANI, RADIO REFERENCE HANDBOOK	16/9 6d.	SMITH: RADIOTRON DESIGNER'S HANDBOOK	6/- 6d.
EVERYBODY'S RADIO MANUAL (How to Build & Repair Radio Receivers)	7/6 9d.	CHUTE, ELECTRONICS IN INDUSTRY	35/- 1/-
AUSTRALIAN OFFICIAL RADIO SERVICE MANUALS: (4 Vols. covering Sets manufactured in 1937-38-39 and 1940-41) (each)	15/- 9d.	ATHERTON, PRINCIPLES OF RADIO FOR OPERATORS	23/6 9d.
GHIRARDI, RADIO PHYSICS COURSE	40/- 1/-	TUCKER, INTRODUCTION TO PRACTICAL RADIO	26/3 9d.
GHIRARDI, MODERN RADIO SERVING	40/- 1/-	MARCUS, ELEMENTS OF RADIO	28/- 1/-
COOKE, ELECTRONICS DICTIONARY (An Illustrated Glossary of Terms used in Electronics and Allied Subjects)	35/- 1/-	TERMAN, RADIO ENGINEER'S HANDBOOK	42/- 1/-
MARCUS, ELECTRONICS FOR ENGINEERS	42/- 1/-	HALLOWS, RADAR SIMPLY EXPLAINED	12/- 6d.
STRANGER, OUTLINES OF WIRELESS SCROGGIE, FOUNDATIONS OF WIRELESS	17/6 9d.	LADNER, SHORT-WAVE WIRELESS COMMUNICATION	54/3 1/-
STRANGER, MATHEMATICS OF WIRELESS	10/6 6d.	RIDER, FREQUENCY MODULATION	16/- 6d.
HOW TO BUILD & OPERATE SHORT-WAVE RECEIVERS	9/- 6d.	HIND, FREQUENCY MODULATION	28/- 1/-
	4/- 3d.	RIDER, SERVICING SUPERHETERODYNES	16/- 1/-
		RIDER, INSIDE THE VACUUM TUBE	36/- 1/-
		CAMERON, SERVICING SOUND EQUIPMENT: (Includes Sound Pictures, Public Address, Radio and Television)	68/- 1/3
		RADIO FOR THE MILLIONS: (Published by Popular Science Magazine)	10/6 9d.

ALL MAIL ORDERS DESPATCHED BY RETURN MAIL
WE CAN ARRANGE SUBSCRIPTION TO ANY RADIO MAGAZINE — PRICES ON APPLICATION

TECHNICAL BOOK & MAGAZINE CO. 297-299 SWANSTON STREET
Opp. Old Melbourne Hospital
CENT. 2041. MELBOURNE, C1.

F.F.R. AMPLIFIER PARTS LIST

RESISTORS:

- 2—50-ohm centre-tapped resistors.
- 2—100-ohm wire-wound resistors.
- 1—600-ohm 1-watt resistor.
- 1—Special 1,000-ohm 10-watt resistor with adj. clip.
- 1—5,000-ohm 1-watt resistor.
- 1—10,000-ohm extra heavy (20-watt) resistor.
- 3—25,000-ohm 1-watt resistors.
- 1—30,000-ohm 3-watt resistor.
- 3—250,000-ohm 1-watt resistors.

CONDENSERS:

- 5—.1 mfd. 400-volt.
- 5—8 mfd. 525v. electrolytics.

SPECIAL COMPONENTS:

- Power transformer type 5176.
- Filter choke type 102512.
- Smoothing choke type 50825.
- Audio transformer type AR2.
- Output transformer AW5.

VALVES:

- 3—6J7G (or 6SJ7GT).
- 2—807.
- 1—5V4G.
- 1—5Y3G (or 5Y3GT).

Suitable base, panel, cover, valve sockets, valve cans, power lead, screws, lugs, etc.



and be guided by it in regard to three most important matters; viz., the arrangement and shielding of the input circuit, the grouping of the earths and the fitting of resistors and condensers at the sockets of the 807's.

Getting back to the grouping of the earths, we may cite as an example the earthing of the grid resistors of the first two stages.

Check on the picture diagram and note how they are grouped, then earthed, not earthed indiscriminately as is often permissible with ordinary amplifiers or radio sets.

VALVE SHIELDS

It is most important to earth the No. 1 pins of the 6J7G sockets. Some people have an idea that as these valves are not metal-sprayed or anything like that, the matter of earthing the No. 1 pin is not important. With this amplifier it is important and should be carried out exactly as shown on the picture diagram.

If the 6J7G's are fitted with valve shields of the "Goat" type, care should be taken to see that the shields are earthed to the base and not the cathodes, as is sometimes arranged by the use of a valve shield which has a strip connecting to the cathode pin on the valve base. If these shields are used, the strip should be taken across to connect to the No. 1 valve pin, which is earthed at the socket terminal as previously mentioned.

INPUT ARRANGEMENTS

As shown in the picture diagram, the input from a pick-up or detector unit is fed through an octal plug in an octal socket. The No. 1 pin is the earth connection, with the input on pin No. 5. Pin No. 6 of the socket is used as a handy terminal for the neat mounting of the

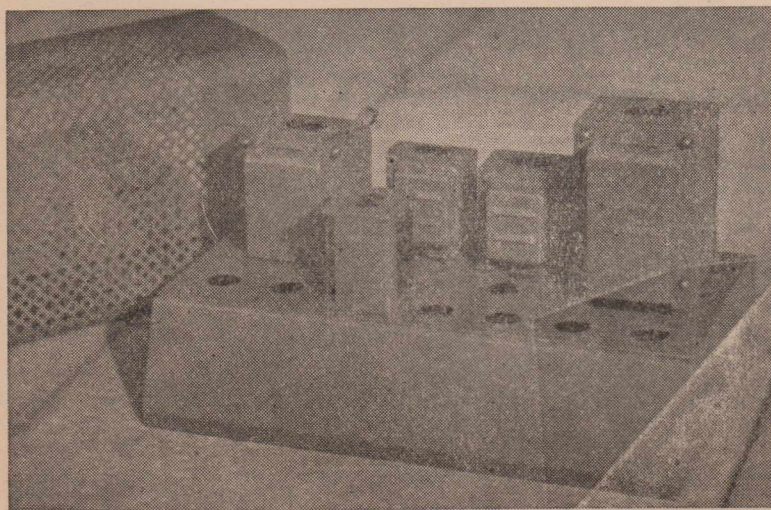

The special base and the specialised components which have been made available for this amplifier.

Special Component 3

SMOOTHING CHOKE

RED LINE. TYPE No. 50825

Primary Inductance at 80 mA: 20 Henries.

Primary Inductance at 30 mA: 24 Henries.

Primary Inductance at 20 mA: 30 Henries.

Maximum Current: 100 mA. D.C.

D.C. Resistance: 500 Ohms.

Base Area: 3" x 3".

Height: 2 3/4".

Weight: 2 1/2 lbs.

Price: £1/6/-.

This unit is specifically a smoothing choke designed for those applications where a large degree of smoothing is required in condenser input filter systems. Under these conditions the ripple voltage is not usually high and voltage regulation not a prime requisite.

The same mechanical features are included as in Type No. 102512.

.1 mfd. condenser. The octal plug is used with only two connections, earth and input, to pins 1 and 5, respectively.

THE BIAS ARRANGEMENTS

Fixed bias for the output valves is obtained by returning the 807 grids to earth, but keeping the cathode circuit at a positive voltage (about 27 volts) in respect of earth. This voltage is obtained from the voltage drop across portion of one of a pair of bleed resistors across the auxiliary high tension supply. It should be clearly noted that the whole of the plate current of the 807's keeps to its own circuit, returning to the centre-tapping of the 730 volt, and since it does not flow through the 1,000 ohm tapped resistor, it does not have any influence on the bias. It should be noted that the 10,000 ohm resistor carries a bleed current of about 30 milliamps, since it crosses about 300 volts. This means that it has to dissipate about 9 to 10 watts, so that a heavy-duty resistor is essential, in fact, one with a 20-watt rating is none too heavy, if you want trouble-free operation over extended periods.

THE OUTPUT TRANSFORMER

Possibly one of the most important of the special components is the output transformer. This item is designed to feed into a 500-ohm line, common practice in talkie and professional amplifier work, but probably not so well known in amateur amplifier circles.

(Continued on next page)

F.F.R. AMPLIFIER

(Continued)

The speaker needs to have an input transformer rated to suit the 500-ohm line. This means that the signal passes through two transformers before reaching the voice coil, which might appear to be inefficient.

It might be possible to operate the amplifier without the special O.P.T., simply feeding to a speaker with an input transformer rated 12,000 ohms plate-to-plate load, but this is not likely to give high fidelity at high power output unless the transformer is exceptional.

One of the secondary advantages of the 500-ohm line is that the line can be quite long, up to hundreds of feet, before it has any serious adverse effect on performance.

STOPPING PARASITICS

Possibly the most important thing about this amplifier is to keep it completely free from parasitics.

This can best be done by paying the greatest care to the mounting of the components which are connected to the sockets of the 807's.

Special Component 4

AUDIO TRANSFORMER

RED LINE. TYPE No. A.R. 2

(Sub-Panel Wiring)

Primary Impedance: 20,000 Ohms Plate to Plate.

Primary Inductance: 240 Henries measured at 10 V. A.C. with D.C. component balanced.

Secondary Impedance: 5,000 Ohms Grid to Grid. D.C. resistance, 840 Ohms.

Driver Tubes: Medium resistance tubes plate current will reduce Triodes, i.e., 6J7G(T).

20 per cent. unbalance of Driver primary inductance to 150 Henries.

Base area: 3" x 2½". Cut-out: 2" x 1½".

Weight: 2½ lbs.

Height: 3½".

Price: £4/11/-.

Transformers are usually dispensed with in A class amplifiers, if possible, in favour of a more economical resistance - capacity coupling, especially as a poorly designed unit seriously restricts the range and can be the cause of instability. However, rectification effects in the grid circuit of most high power output tubes are sufficient to cause departure from the desired condition, and excessive voltages are required for the

drivers to eliminate the introduction of distortion by them. Also, to obtain good low frequency response in a low impedance grid circuit, large condensers of high voltage rating and very low leakage are required, and their cost approaches that of a good transformer.

The A.R.2 unit has a 4:1 impedance step down to reduce the effects of capacity shunting in the grid circuit and to increase the regulation of the signal, as even in A class operation the grid load is non-linear. With this step down ratio the resonance of the primary with low-gain triode plates has been made to occur outside the audible band, and at a frequency well removed from the secondary resonance, so that a sharp high frequency rise is avoided. Terminated, it is within 0.25 db. from 25 c.p.s. to 15,000 c.p.s. and can transfer 55 volts grid to grid at 30 c.p.s. without running into iron distortion. This exceptional frequency characteristic is made possible by the use of high permeability nickel-iron alloy core material and careful application of high-frequency coupling technique. Semi-Toroid construction gives complete magnetic and astatic balance, thereby rendering the unit insensitive to magnetic interference or hum pick-up.

In every case the aim is to keep the wiring as short as possible, and with this end in view it is desirable to measure up the .1 condensers for pigtail length, bending the pigtails

until the condensers are mounted snugly down on the pins of the valves, then cut the pigtails and solder directly to the socket terminals so that the pigtail length

THERE'S 1,000,000,000,000,000,000 OHMS

RESISTANCE IN EVERY CENTIMETRE OF

"STYLON"

(Etholex Polystyrene)

3500 volts are required to rupture $\frac{1}{1000}$ thick "STYLON"

MOISTURE ABSORPTION IS ZERO

THE LOSS FACTOR IS MUCH LOWER THAN ANY OTHER KNOWN INSULATION. AVAILABLE IN SHEETS AND RODS—CRYSTAL CLEAR OR BLACK.

ETHOLEX PLASTICS

108 CHAPEL STREET, S1, MELBOURNE

When purchasing, ask for a copy of "How to Machine Stylon"

is not a sixteenth of an inch longer than absolutely necessary.

In the cathode circuit there are the two stopper resistors which should take the form of a single centre-tapped resistor, mounted in such a way that the leads from resistor to cathode socket terminals are not only as short as possible, but also evenly balanced.

The screen stopper resistors are to be soldered directly to the socket terminals, with pigtailed cut down to a quarter of an inch long, or shorter if possible.

VOLTAGE CHECKING

As soon as the amplifier is finished and put into commission, it is highly desirable to make a thorough check of the voltages. Starting with the A.C. voltages across the socket terminals of the valves, this should be the rated 6.3 volts to within a point of a volt.

Next check the bias voltage at its source, reading across the bleed resistor. This should be 27 volts exactly and not more than half a volt out at the most. Then check the screen voltage of the 807's, which is also critical. Reading from screen to cathode at the 807 sockets, this should be 300 volts, with a permissible tolerance of about 5 or 10 volts. Plate voltage of the 807's measured from plate to cathode, should be 600 volts, but this is not as critical as the screen voltage and can have a tolerance of plus or minus about 20 volts before it can be expected to affect results.

THE HIGH TENSION VOLTAGE

Just in case anyone feels inclined to query the high tension ratings, we would explain that, although the main high tension secondary of the power transformer has a rating of 730 volts, the actual high tension voltage, after filtering, is about 600 to 630 volts. This comes about by feeding the output of the rectifier directly into the special choke, without a filter condenser to accommodate the peaks, as with normal condenser-filter systems. This also explains why it is in order to use a 5V4G with such a high voltage rating. The inductance of the choke acts as a cushion

Special Component 5

OUTPUT TRANSFORMER

RED LINE. TYPE No. A.W. 5

Primary Impedance: 12,500 Ohms.

Primary Inductance: 100 Henries measured at 10 V. A.C. with D.C. component balanced.

Secondary Impedance: 500 Ohms transmission line. D.C. resistance —30 Ohms.

20 per cent. unbalance of power tubes plate current will reduce primary inductance to not less than 60 Henries.

Weight: 9 lbs.

Base Area: 4½" by 4½".

Cut-out: 4" by 2¾".

Height: 4½".

Price: £5.

It will be appreciated readily that of all the apparatus in a fidelity amplifier the one which is most culpable as regards restriction on quality is the output transformer.

Commercial units have been tested and sometimes found to be within their frequency response claims, and to be substantially

free of iron distortion at 400 c.p.s. up to the rated power capacity; but capable of less than 10 per cent of this capacity at 30 c.p.s. for even fair distortion percentages.

The A.W.5 unit was designed, therefore, to operate at low induction for full output at 25 c.p.s., yet with a high primary inductance, so that low frequency response may be maintained with a good plate circuit power factor.

Having fixed this end, the high frequency end had to be dealt with carefully, for in this region the compromise of high frequency attenuation versus insertion loss had to be struck.

Type No. A.W.5 has a frequency characteristic of plus or minus 1.5 db. from 25 c.p.s. to 15,000 c.p.s. and no detectable iron distortion in this range.

The insertion loss at full power was 0.9 db., and 0.7 db. at 2 Watts, corresponding to a loss of approximately 18 per cent. of the power input as against the usual 37 per cent. to 50 per cent. (2.0 to 3.0 db) losses normal with ordinary transformers.

to absorb some of the effect of the peaks of the pulsating current coming from the rectifier.

The only filter condenser across the main high tension is fitted after the choke and must run from high tension to the centre-tap of the high tension secondary winding. In order to get a satisfactory voltage rating it is necessary to use two 525-volt electrolytics in series, shunting each with a 50,000-ohm resistor if there is any doubt about their leakage currents being of considerable unbalance.

USING TWIN SPEAKERS

Those who want to get the best possible reproduction from locally-made speakers as available on the market at present should use a pair of speakers, one to handle the lows and the other the highs. Two suitable speakers are the Rola G12 for the lows and the Rola 8/42 or 8/21 for the highs.

Swales and Swann are making available a special frequency dividing network to suit these speakers, in the form of an assembly of chokes, condensers and transformers, to be fitted between the 500-ohm line and the voice coils of the speakers. Owing to the need for close tolerance in such matters as the capacity of the condensers and the inductance of the chokes, it is not considered advisable to

make the separate components available, but these units will be available in a complete and assembled form.

OUTDOOR WORK

For outdoor work the full 45 watts output can be put to good use by feeding it into a number of speakers, from about 6 to 12 speakers for preference, with due regard to matching of loads, of course, and fed from the 500-ohm line.

QUERY SERVICE

By the time this article appears in print we hope to have our new office-laboratory in full swing at the decentralised location, so if you want any further data on any point, just drop a line to Australasian Radio World, Balcombe Street, Mornington, Victoria.

Later articles will deal with the building of suitable tuners to feed the amplifier with signals from broadcasting, for mixers and pre-amplifiers, for tone compensating amplifiers, expanders and other associate equipment. In the meantime it is regretted that it will be beyond the scope of our query service to handle enquiries for special designs for these items for individual requirements.

RADIOTRON APPLICATIONS LABORATORY

We give below some views of the equipment used in the A.W.A. Applications Laboratory, which has now been fitted up on the first floor of 47 York Street, Sydney, to provide improved service and cope with the increasing demands made by manufacturers and others on the Radiotron Technical Resources, which are under the direct supervision of Mr. F. Langford-Smith, the Company's Applications Engineer.

The equipment so far installed includes the latest model A.W.A. Signal Generator, 5-inch Cathode Ray Oscillograph, Beat Frequency Oscillator, Output Meters, and subsidiary equipment, with two high-quality laboratory-type Multimeters.

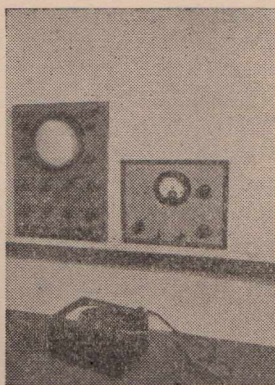

and a number of ordinary Voltmeters, Milliammeters and Microammeters. Distortion is measured by means of a General Radio Wave Analyser. Additional equipment is being built and purchased so as to extend the flexibility of the laboratory, this including v-h-f and F-M testing.

The equipment is grouped in two sections, one primarily covering radio frequencies, and the other audio frequencies, so that work on an audio frequency amplifier may be carried out simultaneously with that on a radio receiver.

A high-grade laboratory type valve tester is now being constructed and will be used in the testing of valve characteristics. This

will include laboratory type measuring instruments with provision for measuring all electrode currents and voltages including positive and negative grid currents, mutual conductance, amplification factor and plate resistance.

In cases where the equipment of this laboratory is insufficient to meet special requirements, arrangements have been made for the use of certain apparatus from the Company's laboratories at Ashfield.

The radio frequency and audio frequency equipment is installed in a screened room so as to be free from radio interference, and is capable of carrying out all normal tests on receivers and amplifiers. This equipment is used in the design of circuits published in Radiotronics

and is also available to assist receiver manufacturers in tracking down faults in receivers, particularly those concerned with valves.

VICTORIAN HEARD ON "SIX" IN N.S.W.

The week-ending November 30-December 1 was noteworthy in Eastern Australia for the protracted short-skip on the 14 and 28 Mc/s band. Throughout the days the 14 Mc/s band sounded like 7 Mc/s in behavior as one found oneself working with country stations around the 200 miles mark. The 28 Mc/s band was remarkable toward dusk for the great signal strength (in Sydney) from VK3's and 5's, with ZL's equally strong in between. It seemed inevitable that something should happen on the next band—"Six Metres," and a careful watch was kept, and calling periods undertaken at VK-2NO.

A schedule with VK2PN, Tumut, N.S.W., had produced negative results at 9 p.m. each night. On the Saturday at 6.45 p.m. Sydney time, a harmonic was noticed on the old "Five metre" band which didn't "feel" like a local . . . it was fading from R2
(Continued on page 34)

CALLING CQ!

By DON B. KNOCK

Activity on the recently-restored 80-metre band is fairly lively among VK's, but the amount of XL activity overshadows it considerably. Noticed a prominent New Zealand old-timer on the job recently in the shape of Dan Wilkinson, ZL2AB. Dan is one of New Zealand's radio pioneers . . . he was officially licensed in 1923. The first four licences in New Zealand, when they were Z's and not ZL's were: Z4AA, Frank D. Bell; Z2AB, Dan Wilkinson; Z3AA, Jack Orbell; and

Z1AA, N. Edwards. Dan Wilkinson's first DX QSO was with A3HL on 150 metres in 1924 . . . which reminds me . . . I spotted in "QST" for September a photograph of the Ham who gave me my own first DX QSO when I was G6XG. It was in 1924 . . . on "200 metres or thereabouts" . . . and the station was Finnish 2NM, Mr. K. Sainio. He is now chief engineer of the Finnish Broadcasting Service and, as the Hams in that country are not yet back on the

air, I imagine that friend Sainio is finding things a bit irksome. He was, and probably is, a keen dyed-in-the-wool Ham . . . he *must* be, or his likeness wouldn't be in a monthly like "QST."

* * *

"T.O.M." had nothing on my feelings the other night when I overheard one of the Genus Moderne VK on 80-metre phone talking to a ZL. Said the very new VK: "I'm going to try one of those antennas I saw in a magazine . . . QS . . . QS . . . QS . . . something or other . . . or some name like that . . . you might know which one I mean." Honestly, fellas, I wouldn't have believed it if I hadn't heard it myself . . . that anyone even remotely interested in Ham radio didn't know the Ham Bible by name better than that. "T.O.M." would tear his hair at such sacrilege! "T.O.M." means, young fella, QST's "Old Man"—who hated rotten operating and the like.

* * *

Have you, too, wondered what is the magic that lies behind the manner in which Johnny Rooks, VK Six "Dog Dog," over in Perth, W.A., bowls over the G's on Ten and Twenty? He uses only a single 807 in the final, but *how* he reaches out! Knowing the facility with which one can QSO Europe from W.A., compared to Eastern VK, I had an open mind about things. But I asked him how come, and got the answer. Merely a little matter of a whacking big rhombic . . . five hundred and fifty-five feet on each leg. And they tell me he is contemplating a rotary beam in lieu thereof. Comparison should be interesting.

(Continued on next page)

GROUND PLANE REACHES OUT ON "SIX"

Since VK2OC, of Wyong, N.S.W., discovered that the 50.4 Mc/s signal from VK2NO, at Waverley, Sydney, was arriving in fine style at his location, progress has been made toward improving the channel. It is now possible to hear and work other Sydney stations, such as VK2WJ and VK-2AZ, and weak signals have been heard from others. The carrier from VK2AFO, Katoomba, has also been heard by VK2OC. All this, be it understood, over a signal path where very heavy screening exists by reason of ranges of hills in between. When VK2NO was first heard in Wyong, reception was by means of any convenient long-wire antenna that happened to be handy. The picture changed from the moment VK2OC made up a ground-plane similar to that at VK2NO and erected it about 30 feet up. VK2NO's signal rose two S points, and VK2WJ came up from R3 to R5. VK2AZ is also workable on C.W. At the time of writing, communication is cross-band, with VK-2OC replying on 'phone on 3.58 Mc/s at 8 p.m. nightly, and the

contacts with VK2NO and 2WJ are duplex speech operation with no mistake about the solidity of the signal on the VHF channel. A puzzling feature of the circuit is why, so far, no Sydney 50 Mc/s transmissions are reported from Newcastle. It is known that there is one efficient receiving set-up at VK2CI, Merewether. Answer lies probably with the use of high-gain beams, and now that the circuit with Wyong is established, plans are under way for protracted tests with various types of arrays at VK-2NO. First to be tried will be a Sterba 4-element. If it does nothing else, the establishment of this VHF channel demonstrates to the F.M. and television interests of future days that intelligent application of ideas well-tried and proved by amateurs, will pay dividends in putting signals into seemingly impossible places. There are listeners to the Sydney 50 Mc/s stations who provide useful and interesting observations. Among these are Mr. Clive Bambury, Lidcombe, N.S.W., and Mr. Godsall, Palm Beach, N.S.W.

—D.B.K.

HAM NOTES

(Continued)

As new stations appear on 40, to say nothing of 20, the gang there are engaged in treading on each other's toes in the maddening, miserable fifty Kc/s so generously (?) provided by kind permission of some gold-laced Signals panjandrums in the seats of the mighty. It's high time something was done about it; the stupidly cramping treatment of Australian amateur radio is something that is quite intolerable when the United Kingdom, the rest of the British Empire, U.S.A., and *her* possessions, and even those who sat on the neutrality fence during the war, are on a different footing. There are no sound Service reasons why VK's should still be kept to that 50 Kc/s, and, as for the pirate broadcasters in the band! Average SWL turns to the 10 Mc/s region for his fare, not 7 Mc/s. Looks as if some day soon a QST editorial of years ago should be put into effect. It said: "We'll mow them down and blast them off." Or words to that effect. If a million or so Hams staged a

sit-down strike (sit on the key with raw A.C. or even *spark*)—perhaps some notice would be taken!

* * *

I wish to draw the attention of the gang to a little-known Philips type of valve with plenty of use around the shack. This is the PE04/15A. Briefly, it is a development of type EL3 in the way that the 807 was developed from the 6L6G. It is suitable for use as audio or RF amplifier. Two in push-pull will deliver 12 watts output at only 2.3 per cent. total distortion for an input of 6.9 volts. For single Class A service ratings are the same as for EL3N. Another useful application is as a Buffer Amplifier (Class B phone), following a VFO. 6.5 volts of grid drive will give 1.8 watts output with zero grid driving power. PE04/15A has a medium 5-pin base and top-cap anode connection.

* * *

Most vivid description I have yet seen of the din that can arise from one's speaker or phones, where a nearby station is putting out "splatter" or "monkey-chatter" on 'phone

is in an issue of G6FO's excellent "Short-wave Magazine." The scribe, my old friend, G6QB, says something about "his phones on the bench making an awful Donald Duck kind of noise." Which just about sums such things up!

* * *

Been hearing a few ZL calls on "40" lately, but as yet have no gen as to whether or not these are genuine. Suggestion has been made to me that they are VK pirates. At the risk of being accused of saying "told you so," I emphasise that I am not a bit surprised. The way complete ex-Service gear is selling in the cities at a few pounds per . . . what can we expect? I do, however, ask all who value Ham radio to boycott known pirates. Encouragement of piracy can lead only to trouble for Ham radio in general.

* * *

Did you see the "blue" in the Sydney leading daily . . . the grand announcement from Canberra that "19,000 to 30,000 Kc/s" is now available to licensed experimenters? Just a little matter of a figurative slip on somebody's part; but I have an observation to make. With all due respect to our regulating authorities . . . they couldn't protest overmuch if some *had* taken the news literally! When no individual communication reaches licences as was the case pre-war, reliance on the great dailies and the grape vine is not much of a show. There was a saying among Army Sigs officers about newspaper announcements "beating the official gun" . . . we called them "Part 3 Orders."

* * *

What *is* this unpleasant spirit that appears in some phases of amateur radio, similarly to life in general, in this post-war world? Give and take and tolerance are oft-times lacking in the simplest of things. The other night two Sydney VHF men were QSO a distant station. No less than four times they looked over the band to call in any other would-be participant. One was heard, calling CQ, and both of them answered the calls repeatedly, with no answer. An opinion by one of the stations that

"ONE-AND-THREE-QUARTER" SWALLOWS

Around the Sydney area there are a few enthusiasts who make regular use of "One and Three-quarters," but as with "Six" there have been birds of passage that have come and gone. One or two individuals arrived on the band and opined that they would use the right kind of gear and show the others how it is done. Which might have been all right, but efficient *reception* is something these wisecracks didn't reckon with. It is one thing to make 100 watts of R.F. perform with modern VHF tubes of suitable rating by merely push-pulling them in linear fashion and checking frequency. With any kind of a half-wave radiator the signal is likely to be heard in all places within line-of-sight. But to hear the modest fellow with his 5 watts of transceiver coming back is a horse of a very different colour, especially with badly-adjusted, aggressively hissing "Rush-boxes." So

the birds of passage have flown off with the wind, or something, and are to be heard grazing in other frequency pastures where DX stations are two a penny. The faithful stick to the band, however, and seldom a night passes in Sydney without signals from VK's 2WJ, 2AFO, 2LZ and 2ABZ on the band. The latter has raised his signal from a whisper to a full R Maximum by the simple expedient of a folded dipole, fed with the much-discussed P.V.C. (Nylex) wire. Despite the fact that 2ABZ uses the aerial horizontal, his signal is extremely strong at my location, and reception (and transmission) are done at VK2NO on a vertically polarised 4-element Sterba array. New stations on the band, and going great guns, are Neil Piermont (VK2NQ) and T. Kinsella (VK-2FK), in the Watson's Bay-Rose Bay area.

the CQ caller "must have a faulty receiver" resulted in a Ham with a distorted outlook on things in general attempting abuse over the land-line. Which, of course, resulted in one thing only . . . immediate abrupt termination of the affair by replacing the telephone receiver. One can hardly treat a nurser of imaginary grievances as the actions of a friend. Which is a pity . . . I like to think that most, if not all, fellow Hams are members of a fraternity.

* * *

Latest in the overseas world of amateur radio is at this period (4/11/46) news that the Americans have been given the whole of the pre-war 14 and 7 Mc/s bands. There is evidence that the F.C.C. there must have been busy clearing commercials out of the bands, for many familiar signals are now observed to be outside the 14 Mc/s band. Quite a relief to get rid of such overpowering signals as ZL03 and a few of the burbling teletypes.

Echo answers meanwhile any question about the broadcaster pirates inside the 7,000 to 7,300 Kc/s range . . . "Radio Australia" and the B.B.C., to say nothing of nondescript foreigners. The W's have a way about them, of getting things done, as they demonstrated so refreshingly in this part of the world when the outlook was grim. Maybe they can be instrumental in booting the broadcasters out of it . . . here's hoping. Which, of course, brings me to a vital question: when do VK's come into the wider band picture? Your guess is as good as mine, but everybody's gorge is rising about the 50 Kc/s on "Forty." We have just about "had it."

* * *

People in glass houses should not throw stones. Overheard a remark from a local phone on a popular band t'other night. I had just answered an interstate call and the local man opened up to call another local. An aside from a visitor at the local urged him to "burn my receiver up," which didn't work out for two reasons. One, the local was clear of the frequency I was interested in at the time; two, I

have a really effective crystal filter that permits complete rejection of unwanted signals to the tune of a handful of cycles. There is a third point: that those who think that being armed with a microphone and a few watts of R.F. gives them a priority on amateur radio may be in for a rude awakening. Where, oh where, is this mythical spirit of amateur radio that I have heard garrulous individuals prating of? It is no demonstration of that "spirit" to go on cluttering up the DX bands with aimless jabber over a few hundred yards distance when there are VHF bands going almost unused.

* * *

VK3NW reports a test schedule on Sundays with VK6, inspired by a report that VK6HM heard signals at 1 p.m. on Sunday, 29th September last. That *would* be something to achieve, and would run parallel with cross-continental working as done on a band fairly regularly in U.S.A. Again . . . all a matter of population. At the time VK6HM heard the signals, VK3NW was perched up in the ranges at Olinda, operating portable. Frequency quoted by the Westralian is 51.4 Mc/s, but Ken says that doesn't

AN OPPORTUNITY

Because of the design of a brand-new receiver for general amateur band purposes at my station, the original "VK2NO V Six" receiver is offered to any A.R.W. reader for purchase. Since the original description of the "V 6," it has been altered slightly to include an RL7 R.F. stage ahead of the ECH4 converter, and a cathode follower second detector. I.F. channel has been changed to 465 Kc/s. Reason for willingness to part with the receiver is simply because there isn't room for this and others on my operating table. No reasonable offer refused.

—D.B.K.

register with him, as VK3ANW (his portable call) was batting it out on 50.51 Mc/s.

PHILIPS JOIN THE MARCH OF TIME

During the dark days of the occupation of Europe, scientists in Philips Research Laboratories secretly continued their experiments with atomic force. Long before the war Philips had been interested in solving the secret of the atom. It was this firm that built the giant generator for the Cambridge laboratory of the late Lord Rutherford, who was a pioneer in the field of atomic disintegration.

These wartime Dutch scientists, having no means of contact with their overseas fellow physicists who were engaged on parallel studies, recorded part of their work in a short film called "Splitting the Atom." The film was made practically under the noses of the Ger-

man overseers. After the war the film was taken over to Philips' New York office, and a section of it has since been incorporated into the new March of Time film, "Atomic Power." Using special motion picture photography, this section gives a three-dimensional pictorial description of the elementary principles of atom splitting. It is further explained by an animated sequence.

Like previous issues of the March of Time, the new film should be excellent cinema journalism—authentic, impartial and dramatically presented—and of particular appeal to all who are interested in the atom . . . and these days that's just about everybody.

MULTIMETER

(Continued from page 9)

which connects to the nearest meter terminal. You can see how the potentiometer is connected up—one end being left free. When you have completed your wiring, you will find that you will have two wires with nothing connected. One will be a wire coming from the end of the 1,150 ohms resistor, and this will go to the positive side of the battery. The other will be a wire coming from the ohms terminal to the negative side of the battery. Place your battery in the battery clip provided, and solder your wires carefully on to the battery, thus completing the wiring. The whole instrument is now wired for use as a D.C. Multimeter, and before using you are wise to check over all your connections, making sure that the joints are perfectly well made, and that no mistakes have been made.

The D.C. version, when completely wired, will have one tip socket not connected. This is for the A.C. section later on. In the D.C. version the tip jack socket marked "O.P.V." is unwired, and no condenser is connected here. Actually, this is the only one that is completely unwired, but, of course, when you add the AC section other wires will come from the switches, tip jack sockets and so on.

If you have carried out all the wiring instructions correctly, you are now ready to use the Multimeter. The final job to be done is to attach the handle to the top of the case by means of the screws and washers provided—place the lid on to the case, and screw the four self-tapping screws into the holes provided, making sure that they are tight. You now have a complete Multimeter which compares favourably with any commercial job on the market.

For safety sake be careful in your first measurements. Measure a

known source of low voltage, say, a six-volt battery, starting off on the thousand-volt range, and, if there is a slight deflection, then it is O.K. Come down to the 250-volt range, and you should have a bigger deflection. Go on down the ranges until you are quite sure that you can use the instrument on the 10-volt range, then off you go. This is a good point in making all measurements of unknown value. Start off on the highest range and work down.

To test the ohms section, put the test prods provided in the appropriate tip jack sockets and touch the prods together. The needle should then swing over towards the zero end of the Ohms scale. Turning the potentiometer one way or the other should bring the meter needle directly on to the figure "0" on the ohms scale, and from then on you can measure resistance. Before measuring resistance, at all times, make sure that the potentiometer adjustment is made before measurements are taken.

ADDING THE A.C. SECTION

To add the A.C. section there are only four parts to consider. First of all screw the rectifier on to the hole provided on the main resistor panel. Next, put in the change-over switch in the position shown in the photograph, and after you tighten the nut on the switch, fit on the knob provided, which will be found to have a small white line. After you make sure that the switch is in the right position, and the lock nut tightened, turn the switch with a pair of pliers to the extreme right or D.C. side. Fit the knob so that the white mark on the knob points to the letters "D.C." on the front panel and then tighten it. By then turning the knob to the left hand side the white line should point to the letters "A.C.V."

The first step in the wiring is to take the .25 mfd. condenser and solder it on to the two appropriate tip jacks. One end of the condenser is soldered to the solder lug held on by the nut on the double circuit tip jack. Do not solder this condenser on the large contact on

this tip jack, but on to the little solder lug which is actually underneath the nut on this.

The other end of the condenser is then soldered on to the lug under the nut on the tip jack marked "O.P.V." A wire also comes from the lug on the double circuit tip jack round to the switch. At this point carefully study your back of panel wiring diagram for the A.C. section, and make sure that the condenser is connected to the appropriate contacts. Here we can only advise you to carefully study the wiring diagram of this switch and see that the wires come from the appropriate contacts to the places shown in the diagrams and photographs.

A word of warning about soldering to the rectifier. Excessive heat can severely damage rectifiers. You will notice that the rectifier has four wires coming from it. Two of these have little white blobs, and the other two have a black and a red blob. The black is obviously negative, the red is positive and the whites are A.C. Be careful that you solder at the extreme ends of the wires, and do not touch the rectifier at all. Take the connections to where they are shown in the wiring diagram, and this will complete the wiring of the A.C. section. Again test very carefully and look over your circuit for mistakes. Your multimeter is now ready for use.

With the A.C. section added, you can measure A.C. voltages from 1 or 2 volts up to 1,000 volts. More important still, you can use the instrument as an output meter when aligning an ordinary radio receiver or making measurements of output by inserting the test prods in the appropriate tip jacks and placing on the output of a receiver.

The whole instrument is completed as an A.C./D.C. Multimeter which is modern and up-to-date. It uses an improved circuit, and, with careful use and attention, will give you many years of successful and satisfactory performance.

Shottwave Review

CONDUCTED BY

L. J. KEAST

NOTES FROM MY DIARY

"MANY HAPPY RETURNS"

The Canadian Broadcasting Corporation celebrated their tenth birthday on 10th November and the BBC marked the occasion with a birthday present in the form of several programmes specially produced in London for broadcasting in Canada.

MOTORISTS PLEASE NOTE

How often have you been waiting for that call-sign when, just as the "foreigner" in broken English commences to give it, a motor car passes by? There is only one thing to do . . . wait till the same time tomorrow. But that would hardly do if it was Television that had your attention. Here is what the BBC have to say in "London Calling":

"Now that the BBC's Television Service is in full swing again in England, the owners of motor vehicles are co-operating by fitting suppressors on them so as to reduce interference with television reception.

"Suppression of ignition interference is a simple matter and, in most cases, merely calls for the insertion of a 15,000 ohms resistance in each sparking plug lead, and one of 5000 ohms in the main distributor lead, but it is important to 'viewers' who are apt to be infuriated when, say, the winning shot of a Wimbledon championship tennis match is blotted out by interference from a passing car."

THE 41-METRE BAND

Here is a cutting from "London Calling" of October 3rd: "The use for broadcasting of frequencies in the 7-megacycles-per-second (41 metre) band has been questioned in letters to the BBC by amateur radio experimenters in North and South America. They imply that, as this band was allotted exclusively to amateurs, broadcasters had no right to use frequencies within it.

"The complainants appear to have overlooked the revised allocations of frequencies made at Cairo in 1939. Under the Madrid regulations of 1932, the whole band from 7,000 Kc/s to 7,300 Kc/s was reserved exclusively for amateur use, but under the Cairo Conference regulations, which became effective on September 1, 1939, the band from 7,200-7,300 Kc/s was shared between amateurs and broadcasting.

"While, therefore, the BBC is justified in using these frequencies for its broadcasting services, it naturally does not wish to interfere with the activities of amateurs, and will always seek to avoid such interference by choosing frequencies in other broadcasting bands when these are suitable and available.

"As solar activity is now increasing, the BBC expects to be able to maintain its services to the Americas during the next few years without recourse to the 41-metre band, thus reducing to a minimum interference with amateur activity."

BBC QUIZ

No, this is not the usual type of quiz that carries a prize of £500 or so but the reward for joining in is quite worth while as it is from the answers received that better transmission is made possible:

"The BBC has a Listener Research Department, which regularly conducts scientific inquiries into the listening habits of the British public . . . what programmes are most popular, and why, when are the best times for broadcasting certain types of programme and so forth.

"Just imagine the surprise one of the Survey interviewers of Listener Research received when visiting a remote farm in Glamorganshire, Wales, he learnt that the farmer had no idea what BBC stood for . . . he had never seen or heard a wireless set and did not even know that wireless existed.

I.T.M.A.

Yes, it's that man again, and those fortunate enough to be able to tune to the BBC Pacific service can hear Tommy Handley every Monday at 4.45 p.m.

ALTERATIONS TO "RADIO AUSTRALIA"

VLA-9, Shepparton, 21.60mc, 13.89m, replaces VLA-6 from noon-2 p.m. in programme to Forces in Pacific, Japan and Asia.

VLG-7, Lyndhurst, 15.16mc, 19.79m: Is heard on Saturdays only from noon till 5.20 p.m. to above.

VLB-2, Shepparton, 9.68mc, 30.99m: Replaces VLB-6 on Saturdays only from 2.45-3.45 p.m. to North America (West).

VLA-4, Shepparton, 11.77mc, 25.49m: Here is an additional transmitter used on Saturdays only from 5-6.15 p.m. to British Isles.

VLC-10, Shepparton, 21.68mc, 13.84m: Same remarks apply as to VLA-4.

VLA-6, Shepparton, 15.20mc, 19.74m: Replaces VLG-5 from 6.45-9.30 p.m. to Forces in Pacific, Japan and Asia.

VLG-10, Lyndhurst, 11.76mc, 25.51m: Replaces VLG-5 from 8-10 p.m. in programme to Asia.

VLG-9, Lyndhurst, 11.90mc, 25.21m: Replaces VLG-5 from 10-11 p.m. in programme to Asia and Forces.

VLG-10, Lyndhurst, 11.76mc, 25.51m: Replaces VLG from 2 a.m.-3 a.m. in programme to North America (West) and South Africa.

* * *

SAYS WHO?

JODK, Seoul, Korea, 2.51mc, 119.1m, has English identification each half hour.—Cushen.

13-metre band has had some attention . . . great reception . . . VLB-8 at night has been a surprise, the best reception of any Radio Australia on 13-band.—Gaden.

The CBC stations, CKS, 15.320 mc, 19.58m, and CKRA, 11.76mc, 25.51m, commence broadcasting at

9.25 a.m. For the first five minutes programme particulars are given and then a news service. Reception is fair on opening but by 11.30 is difficult to follow.—Suffolk.

Rex Gillett thinks he has been hearing ZNB, Bechuanaland. This is what he says: "A station on about 5.90mc, 50.85m, seems it may be ZNB, Mafeking. Recorded music was heard from 4.30-5.30 a.m., then 'God Save the King.' Signals were fair but I could not positively identify the station."

KWS-1, Vienna, 9.833mc, 30.51 m, is now putting in a splendid signal at 6.30 a.m. and can be copied without trouble, although COBL, Havana, is almost on an identical frequency.—Suffolk.

Mr. E. A. Anderson, of 99 Hanbury Street, Kalgoorlie, W.A., writes: "It is with much interest that I follow your short-wave loggings in 'A.R.W.' I received my October issue today (4th November) and read where Mr. Frank Brockbank of Auburn and yourself are enquiring about the BBC outlet GVS, 21.71mc. I have followed this BBC station of GVS for about three weeks regularly each day and it is steadily increasing in carrier strength and at present of good standard. I am an engineer on 6KG and for the last four nights find it of A1 strength to use for rebroadcasting the 7 p.m. (W.A. Time) news. Tonight (6.30 W.A. Time) GVS is crystal clear and is now free from sun spots static.

"The BBC transmitter has been carefully watched by me for the last 14 months and between the months of September and February this year . . . the BBC on 13 metres was excellent and appears it will be good in 3 or 4 weeks' time. GVS will be under my eye from now on and I will be only too pleased to notify you of any changes of this BBC outlet during the season if you require same. GVS is first audible about 8 p.m. and fades completely by 2 a.m."

(Thank you, Mr. Anderson. Am sure the BBC would be pleased to hear direct from you and, as they

now verify, you will be repaid for your trouble.—L.J.K.)

And here is a fine budget of news from Rex Gillett of Adelaide: "Have been very fortunate with veries, five new countries having been added in the past month, bringing the total to 66, an increase of 38 in the last 12 months. The new countries are Albania, Siam, Belgium, Marshall Islands and Poland. Radio Tirana verified by means of a letter in French. Address is: Republique Populaire d'Albanie, Direction Centrale de la Radiodiffusion d'Albanie, Rue Conference de Peza 3, Tirana, Albanie. Belgium verified by letter in English their 17.845mc outlet after a period of 10 months. Schedule for this station operated from Ruysselede is as follows: 5-5.30 p.m.; 9-10.30 p.m.; 2-3 a.m. and 5-7.30 a.m.

"This transmitter is a 5KW S.W. telecommunications job. Identification is given at the start of transmission as 'Allo Leopoldville, Allo Leopoldville, ici le service Mondial de l' I.N.R.'

"Poland verified by air mail my report for October. I received same together with photo of station on November 1st . . . very good time, you will agree. Another fine verie was that of H58PD (note official call), Bangkok, Siam. This very colourful card with a yellow background has a map of Siam and below the map the sky line of Bangkok, both being on white. Down the left-hand side are stripes of red, white and blue, the stripes being broken into at the top left-hand corner to take an insignia. This card is a worthy addition to any collection. The card had Thailand printed on the map and has SIAM inked in over it, so I am tipping this is their old card."

(Well, Rex, that's a fine bunch of veries. I have some old programmes of the Bangkok station about my den somewhere. If I can lay my hands on them, will forward one or two, as it will help you with the language.—L.J.K.)

Miss Sandersonn, of Malvern, Victoria, also sends some interest-

ing information: "Conditions have been pretty good, but quite a bit of noise and morse. I have been concentrating on South and Central Americans and have heard several at very good strength and clarity. Panama stations have a very good signal and interesting programmes. HP5A opens at 10 p.m. with the national hymn in a good clear channel, for the BBC seems to close before the Panama station opens.

"AFRS stations in China have been heard at fair strength with the usual variety programmes, notably XRRA, Peiping, and XUPB, in Amoy, but conditions have to be good to hear these programmes as there is a fair bit of noise on this band. COKG is in the clear at 9.30 p.m. and is good listening.

"XEHH, on 25.56, and XEYU, on 31.21m, are heard at good strength, the latter announcing as Radio Universal Nacional. The usual Spanish programmes are given with the interval signals of gongs between announcements.

"I received a verie from Radio Andorra, together with a schedule of programmes. Prague is heard in an English session at 6.30 a.m. and is very good listening; is easily identified by the notes of the French horn.

"I am very pleased with 'Universalite' and find it very useful. I have sent a report to Mr. Howe."

A verie received in Adelaide from Radio Leipzig gives the address of Mitteldeutscher Rundfunk Sender Leipzig, Leipzig N.22, Springerstrasse 24, Leipzig, Germany. Berlin operates on 6.07mc, it is stated, whilst Leipzig is on 9.73mc. Both are Russian controlled.

Here is a fine bunch of notes from Rogge Legge, of Binghampton, U.S.A.: "HIG, Ciudad Trujillo, 6.115mc, 49.06m: Heard till sign off at 1.30 p.m. YSF, San Salvador, 9.25mc, 32.44m: 'Radio Vanguardia' heard from 11 a.m. till 1 p.m. (This station was reported by Arthur Cushen on 4th October and apparently replaces

YSR "La Voz de El Salvador" on the same frequency.—L.J.K.)

"Referee Airways,' Galapagos Islands, 4.22mc, 71.09m: Heard around 1 p.m. contacting other airways stations. Verified promptly. Address is 153 AACS Sqd. APO 662, c/- P.M., New Orleans, La. (Mr. Legge asks: 'Do any of the Dx-ers down there listen on 4.22 mc? There is ACS network on this frequency with stations all over the world, including many of the rare Pacific Islands that should be audible in Australia. I heard mostly Atlantic area stations, such as

Greenland, Antigua, St. Lucia, Trinidad, Casablanca, etc.)'

"TGLA, Guatemala, 6.295mc, 47.68m: 'La Voz de Centro America,' heard till sign off at 1.30 p.m. TGRA, Guatemala City, 6.255mc, 47.96m: 'La Voz de la Guardia Civil' heard till sign off at 1 p.m. (This station replaces TGNA, 'La Voz de Libertad.'—L.J.K.) HOB, Panama City, 6.175mc, 48.48m: 'Radio Panamericana' heard 11 a.m.-1 p.m. ZMB6, Apia, 7.70mc, 39.15m: This Western Samoan station was heard with test broadcasts 3.05-4.05 p.m., but seems to be off now."

that closed at 7 a.m. with "God Save the King." I tried for many mornings but could not catch the call-sign even if it was given. After about a week I rang my good friends, George Muller and Ray Simpson. The latter finally "caught" them although for a few mornings he could not hear them at Concord, although the signal at Randwick (where I then lived) was quite good. And for his report of 1st Dec., '39, he received a verification dated 2nd Jan., '40. However, the verification stated station was on 7.20mc, but this was wrong . . . it was definitely on 7.31mc. Since then it has moved to 6.00mc, or and 3.658mc, so apparently Ern has logged the oldtimer on a new frequency. Congrats, Enr.—L.J.K.)

NEW STATIONS

VUD, Delhi, 21.51mc, 13.95m: Dr. Gaden reports hearing this station at night. Announcement at 11 p.m. gives frequency and mentions station is directed to Africa and Asia. Unfortunately no call-sign is given but the programme can also be heard on two frequencies in the 19-metre band, 15.19 and 15.16mc and also on 11.87mc in the 25-metre band. Whilst the 13-metre signal is not as loud as the other three mentioned, it is freer from static and consequently makes good listening. (This station is also heard around 4 p.m.—L.J.K.)

—, Salisbury, 3.66mc, 81.96m: Ern. Suffolk, of Lobethal, South Australia, reports this Southern Rhodesian station. He logged them first at 5.30 a.m. when a programme of variety music was in progress. At 6.35 a female announcer said: "You are tuned to Salisbury." Station then closed with "God Save the King."

(Salisbury is also listed as follows: ZEA, 7.60mc; ZEB, 6.14mc; ZEC, 5.80mc. Address is: G.P.O. Box 792. I also recall that away back in 1939 I was hearing every morning a station on about 7.31mc

SEAC, Colombo, 7.185mc, 41.75 m: Here is a new frequency for Ceylon. Ray Simpson rang me re this one, which he has been hearing around 5.45 a.m. on Monday mornings with a special session for England. Station appears to close at 6.30.

EPB, Teheran, 15.10mc, 19.87m: This is not actually a new station; it was first reported by Wally Young in 1944, but it is being heard at a new hour, namely, 9.30 p.m. At this time, providing morse permits, news in English can be heard. French follows at 9.45 and then at 10 o'clock Russian. Music is given at 10.15 and station closes at 10.30. Reporter is Rex Gillett.



Sole Australian Concessionaires:

GEORGE BROWN & CO. PTY. LTD.
267 Clarence Street, Sydney

Victorian Distributors: J. H. MAGRATH PTY. LTD., 208 Little Lonsdale Street
Melbourne

The Ultimate factory has made the changeover from wartime production. Designs for the new models are now completed and production is about to commence.

These models should be available soon — they will be worth waiting for. Watch for further announcements.

SERVICE: Servicing of all kinds of radio sets, amplifiers and Rola speakers will continue to be available.

Speedy Query Service

VICTORIAN HEARD ON "6"

(Continued from page 26)

D.N. (Kelvin Grove, Q.) is a subscriber who writes to request that his issue be posted earlier this month.

A.—All subscribers copies are posted as soon as they come off the press. The trouble is that they don't come off the printing press early in the month, and the reasons for this are many and varied. You can rest assured, however, that no matter what the date on the cover, or the date you actually receive your issue, you get the latest and most up-to-date news just as quickly as we can get it to you under prevailing circumstances. It would be simple enough for us to print "December" on the front cover of the issue which we get out in November, but it wouldn't make your news any fresher. Some American magazines have their "December" issues on sale by the end of October, but it doesn't actually make them any more worthy on that account.

Eventually things in general may get back to normal, when we will again be able to get our issues on sale by the 15th day of each month, but at present they seem to run a few days late, there being always some unexpected problem which arises in production.

HEADPHONES

Brand New! Just Released!

**S.T.C. &
STROMBERG CARLSON**

Original cost, £2/10/- pr.

130 Ohms, 10/- pair
2,000 Ohms, 25/- pair

(Postage 1/6 pr. extra)

Can supply in quantity.

DEITCH BROS.
210A GEORGE STREET
SYDNEY

Phone BW 7637

F.E. (Hawthorn) complains that he cannot get attention on our phone.

A.—Sorry, but we are unable to handle technical queries on the telephone, which is one of the reasons why we don't show the telephone number in our issues, or have it listed in the telephone book. We can only suggest that you write your query and submit it by post.

* * *

F.D. (Sydney) wants to know how to measure the voice coil impedance of a speaker.

A.—Quite frankly, we don't know any easy way of measuring voice coil impedances. The simplest way is to enquire from the makers! There is not necessarily any relation between the impedance at a certain frequency, which is what we are after, and the d.c. resistance of the voice coil winding, as can be measured by an ohmmeter.

The old Amplion speakers had low voice coil impedance, the rating for the "03" being 1.25 ohms, if we remember correctly.

* * *

H.H. (Warragul) asks about the Victorian Amplifier Championship.

A.—Yes, the Championship was held again this year, but there was something lacking in the publicity liaison, for, apart from the initial announcement and an appeal for a prize, we did not hear anything about the contest until it was almost over, and so we did not get any editorial matter for publication. So far we have not been informed of the winner's name or any details regarding the final, but if anything comes to hand we will give it due prominence in future issues.

* * *

S.A. (Ashfield) enquires about speaker transformers.

A.—The input transformer to the speaker is probably the weakest link when you start to consider high-fidelity amplifiers working with an output of about ten to fifteen watts and feeding into a G12 or similar speaker. The input transformer as fitted by the makers is all right for ordinary commercial work, but not for full-frequency range at high power.

to R6. This turned out to be either VK3VO or 3VR . . . that last letter is uncertain, on his fundamental on "Twenty" and "calling CQ New ealand"! Approximate frequency of this harmonic was 58 Mc/s. Reason indicated that if a harmonic from VK3 could reach Sydney on 58 Mc/s, a direct transmission on 50 Mc/s certainly should. A message was sent via "Twenty" to Melbourne to start things moving, but nothing further happened that day.

STOP PRESS

History was made December 5 when VK2ND and VK3MJ made first undoubted interstate contact on six-meter band.

On the Sunday, December 1, short-skip conditions were even more pronounced on the DX bands. Much time was spent on "Six" calling and listening. At about 7 p.m. that night, whilst VK2NO was in telephony QSO with VK-2LS, VK2WJ, Maroubra, called on the landline to say that VK3HK on CW had suddenly appeared at R8 plus just alongside VK2LS and had faded out after about four minutes. A few minutes later, VK2NO, keeping the usual evening schedule with VK2OC, was informed by Owen Chapman there in Wyong, that he also had heard VK3HK at terrific strength . . . reaching 20 Db over S9 on his Hallicrafters receiver S meter. The "lifting of the veil" was so speedy that there was no opportunity to do anything about a QSO at either 2WJ or 2NO. An interesting feature about the reception was that 2OC didn't hear the signal until about seven minutes later than 2WJ, and it had faded out at Maroubra by then. This seems to indicate the movement of an ionised cloud or body acting as the reflecting medium. Such periods will occur with increasing frequency in the next 12 months. To take advantage of them an organised calling and listening plan should bring results.

—D.B.K.

RED



LINE

TRANSFORMERS and CHOKES

PRECISION IN DESIGN

Type No. AR2



Type No.
5176



Type No.
50825



Type No.
102512



Type No.
A.W.5

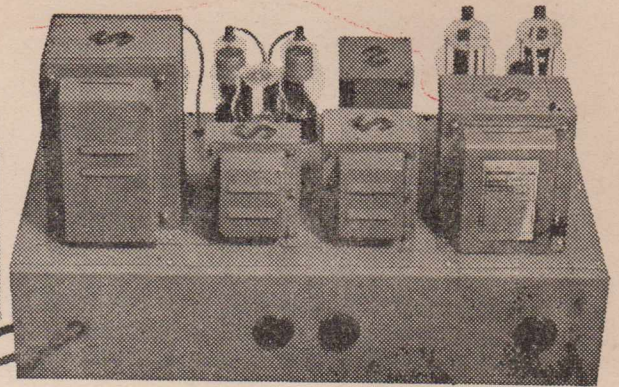

PRECISION IN CRAFTSMANSHIP

SWALES & SWANN

Your Transformer problem will be transformed from a headache to that craftsman-built component which you desire but cannot quite figure out. Swales and Swann specialise in Audio Frequency Transformers up to Frequency Modulation Standards; Power Transformers up to 2 K.W. rating;

BUT

See Swales and Swann for Transformers of ANY specification, whether they are required for Industrial Applications, Electronic Controls, Broadcasting, Amateur Transmitting or Public Address Systems.

Technical Service, Wholesale
and Manufacturers

A. T. SWALES. Central 4773
2 Coates Lane, Melbourne



Trade Sales: Allen SWANN

MU 6895 (3 lines)

157 Elizabeth St., Melbourne

A GUARANTEE

OF DEPENDABILITY

AUSTRALIA SPENDS MORE THAN

£ 8,000,000

**ANNUALLY ON RADIO
RECEIVERS AND PARTS**



This is the last pre-war estimate and it's not hard to realise how even this colossal figure must jump in the post-war period. Incidentally, in the figure quoted, over £1,000,000 is made up of valves, service and parts replacement!

**Huge Waiting Radio Market Means
BIG MONEY For Trained Men!**

**RADIO IS STILL A NEW INDUSTRY
GROWING FAST!**

Today Radio is not only the fastest-growing of Australia's secondary industries, but promises the brightest future. Its needs for trained men are tremendous and are growing every week.

We are entering now a Radio age, an age which has a place for YOU. Radio, a young industry which has made remarkable progress in the past few years, will require trained men to fill vital positions. If you want security, prosperity, and a recognised status in the community, start training NOW.

YOU CAN START RIGHT AWAY
Frequently openings in Radio are greater than the number of men available to fill them. Here are two good reasons, moreover, why A.R.C. Radio Training most interest you so vitally:

- (1) You will enter today's most progressive industry.
- (2) You will have a splendid career ahead of you now that the war is over.

TRAIN AT HOME, OR AT OUR BENCHES

A.R.C. offers ambitious men a sound proven course in Radio Engineering. Sound, because it is the result of many years' successful

operation; proven because hundreds of ex-students owe their present success to the College. You can learn with equal facility at home (by means of our correspondence course).

EARN GOOD MONEY WHILST LEARNING

You don't have to wait a year, or even six months before you are ready to begin "cashing in." We will show you how to earn extra money almost from the word "go." Many students make £4, and up to £8, per week, in their spare time whilst studying.

PREVIOUS KNOWLEDGE UNNECESSARY

You don't need a knowledge of Radio or Electricity—we'll give you all you need of both, in a simple, practical manner, that makes learning easy; presented, too, in such a way that you remember what you're taught and how to put that knowledge to practical use.

COSTS LITTLE

Think of this—for a few pence per day—actually less than many fellows spend on tobacco—you can prepare yourself for a man-sized job in Radio NOW.



£8,000,000 was estimated prewar sales of radio receivers and Parts. The next few years should see these figures doubled.

Pre-war Radio Set output reached an estimated 280,000. All records are expected to be broken in near future.

Even a 25 per cent increase in set sales will mean openings for perhaps 1,000 more Radio dealers—

Over 130 Australian Radio Stations employ a vast number of skilled personnel—a team of specialists which would probably be tripled with the advent of F.M. transmission.

GET THIS BIG FREE BOOK NOW!

**AUSTRALIAN
RADIO COLLEGE
PTY. LTD.**

**Cnr. Broadway and City
Roads, Sydney.**

Phones: M 6391, M 6392



To Mr. L. B. GRAHAM, Principal,
Australian Radio College Pty. Ltd.,
Broadway, Sydney. Phone M 6391-2.

Dear Sir,—I am interested in Radio. Please send me, without obligation on my part, the free book, "Careers in Radio and Television."

NAME

ADDRESS