



RADIO SERVICE NEWS

VOLUME XIV, No. 5

RCA TUBE DEPARTMENT, HARRISON, NEW JERSEY

Nov.-Dec., 1949

RCA-VS036 RADIO "A" BATTERY NOW AT NEW LOW PRICE

Answers Consumer Demand for 10-Cent "Sealed-in-Steel" Radio "A" Battery-Special Profit Package Available

RCA's famous "Sealed-in-Steel" VS036 Radio "A" Battery now costs you no more than ordinary flashlight batteries. The new reduced price is the answer to consumer demand for a ten-cent steel-jacketed Radio "A" Battery.

Merchandising-wise—the RCA-VS036 is tops in value and quality. Steel, top, bottom, and sides, protects the battery against corrosion, leakage, and swelling, and keeps the battery fresh for years, thereby eliminating shelf-life or dating problems. Customers, too, prefer RCA "Sealed-in-Steel" Batteries, because they stay FRESH when not in use and contain a special radio mix which insures continuous receiver operation for long periods.

To help increase your sales, RCA-VS036s are available in standard counter-merchandisers of 24 cells. You can also get them, without additional charge, in the unique RCA CARRY KIT of 8 cells. If you
(Continued on Page 6, Column 3)

RCA ANNOUNCES 15-INCH HI-FI DUO-CONE SPEAKER

**New Unit Acclaimed By
Critical Listeners**

Real high fidelity audio reproduction at a new low price is available now, for the first time, in the new RCA-515S1 15-inch Duo-Cone Speaker. The RCA Duo-Cone is the product of extensive loudspeaker research and development by Dr. Harry F. Olson, one of the world's foremost authorities on acoustics, of RCA Laboratories at Princeton, N. J. It was designed for high-quality radios and television sets, broadcast station monitoring applications, and low-distortion reproducing systems in which high-fidelity response is a major requirement.
(Continued on Page 6, Column 4)

Copyright 1949, Radio Corporation of America

NEW RCA PICT-O-GUIDE—VOLUME II

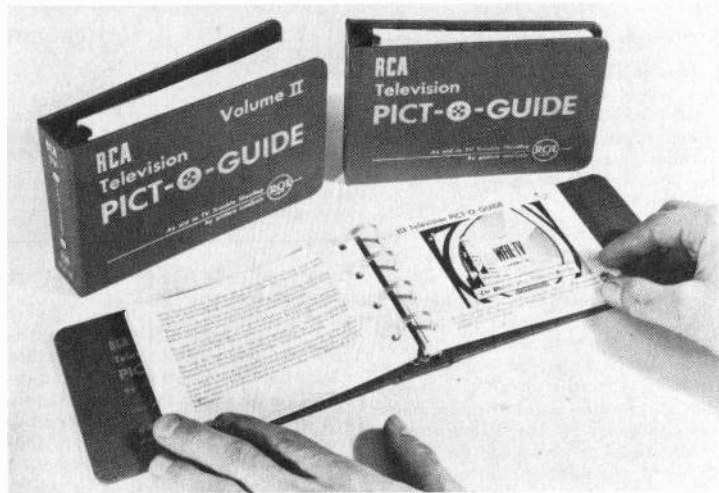

Here are two essential aids to better, more rapid, television servicing—Volumes I and II of the famous RCA Pict-O-Guide. Volume II has twice as many pages as the first volume, and over 20,000 words of practical text. It is available only through your local Distributor without charge when you purchase RCA, RCA Victor or Cunningham tubes.

RCA PICT-O-GUIDE—VOLUME II NOW READY FOR TV SERVICEMEN

John Meagher Prepares Second in Series

In response to the tremendous demand for additional authoritative television servicing information, RCA presents Volume II of the Pict-O-Guide. It's bigger and even better in every way!

Bound for easy handling, in the same distinctive style and color as Volume I, it is an essential addition to your technical library. Volume II contains more than twice as many pages as Volume I and over 20,000 words of text.

The first RCA Pict-O-Guide Volume made a smash hit with servicemen everywhere. Over 20,000 copies of this time-saving profit-building publication have already been distributed, with orders still coming in.

Volume II provides new practical information on alignment, interlacing, focusing, blanking, sync, and interference—essential information applicable to all TV receivers. TV trouble can almost always be isolated to a specific circuit section in a receiver, making the final trouble-shooting job a relatively simple matter of checking a very few components. The RCA Pict-O-Guide helps you to isolate the trouble and identify it by the visual symptoms. Through compari-

son of the TV receiver screen and photos in the Pict-O-Guide, plus the descriptive text accompanying the photos, time spent in diagnosing receiver faults is materially reduced.

Now—here's how you can get your copy of this valuable book. **DO NOT** write RCA or RADIO SERVICE NEWS—copies are not available there. Neither is the RCA Pict-O-Guide Volume II for sale. You can get them, at no extra charge, from your Distributor when you purchase RCA, Cunningham, or RCA Victor Tubes. See your Distributor today—find out how you can get your copies of the RCA Pict-O-Guide, both Volume I and Volume II—have him reserve your copies while the supply is plentiful.

There is still a limited quantity of Volume I of the RCA Pict-O-Guide available. If you have not already obtained your copy of this TV "must," see your Distributor. For more rapid, profitable TV servicing you'll want to have both volumes of the Pict-O-Guide.

RCA RADIO TUNE-UP CAMPAIGN WINS WIDE TRADE ENDORSEMENT

**New Promotional Program
Drawing Tremendous
Trade Interest**

The RCA Radio Repair Tune-Up Campaign, announced in the last issue of RADIO SERVICE NEWS, has moved rapidly into the spotlight as the year's outstanding promotional program. Planned especially for Service-Dealers, backed by Distributors, and praised by Servicemen's organizations, the program offers an outstanding opportunity to cash-in on additional service business.

Thousands of receivers in poor working order, or shelved when they went bad, are being uncovered for "Radio Tune-Up" service.

If You Act Fast . . .

There's still time for you to cash in on this powerful program. If you haven't launched your own "Radio Repair Tune-Up Campaign," we suggest you do so at once. Your RCA, Cunningham or RCA Victor Distributor can supply all the details and arrange for your participation. Let him show you samples of the promotional materials and an outline of the program.

Join the RCA Radio Repair Tune-Up Campaign today through your local RCA, Cunningham or RCA Victor Distributor, and enjoy added profits.

NEW TV ANTENNA IN RCA'S LINE

Rounding out RCA's TV antenna line, the new 214A1 dipole and reflector combination features broadband characteristics and easy mounting. It is designed for use with 300-ohm transmission line and on receivers having an input impedance of 300-ohms. Under such conditions, the RCA-214A1 requires no matching transformers or matching stubs.

Made of tempered aluminum, the antenna features sturdy construction for dependable service.

Suggested list price of the RCA-214A1 is \$9.75. See your RCA Distributor today.

Photolithographed in U. S. A.

RCA TV ANTENNA SELECTION GUIDE SIMPLIFIES INSTALLATION PROBLEMS

This guide has been prepared to aid television technicians in selecting the right antenna for a given location. It attempts to evaluate such factors as signal strength at a given location, distance of the installation from the station, and other important considerations in the choice of an antenna. The television technician is usually acquainted with the relative signal strengths of the stations that can be received in his area and he applies this knowledge in selecting an antenna.

For example, if one station is much weaker than the others, it is advisable to select an antenna that will favor the weaker station. The tabulation on this page shows the recommended RCA antennas for various conditions which include the strength of the signals, the number of stations, station frequencies, and direction of the stations from the receiver. The explanatory notes that accompany the table will prove helpful to many technicians.

How to use the table:

As an example, assume that the following conditions apply in a particular location:

1. All stations are received with medium signal strength.
2. All stations are in the low band, none in the high band.
3. All stations are in the same general direction from the receiver.

These conditions are found in the second horizontal line from the top of the table. The recommended antenna, listed in the first column, is the 204A1.

Note 1. Plain dipole vs. folded dipole. A folded dipole and a plain dipole, cut for the same frequency, intercept the same amount of signal and, when correctly matched, deliver the same amount of power at the resonant frequency.

A folded dipole, connected to a 300-ohm load, delivers more power than a plain dipole connected to a 300 ohm load, at the resonant frequency. On channels higher than the resonant frequency, a plain dipole connected to a 300-ohm load delivers more than a folded dipole.

This is the reason why RCA recommends a plain dipole for wide-band coverage, yet recommends a folded dipole cut to the particular channel when only one channel in the low-frequency band is to be received.

The presence of a reflector cuts the antenna response sharply on the low frequency end. When an antenna and reflector are used to cover several channels in the low band, or several in the high band, it is definitely desirable to select an antenna for the lowest channel, that is, channel 2 for the low band, and channel 7 for the high band. As an example of some of the factors involved consider an antenna with reflector, designed for channel 3. If it is used to receive channel 2, the "reflector" is less than a half-wave long and acts as a director, with the result that reception is weaker toward the front than toward the rear.

A tremendous amount of design knowledge, based on experimental verification and vast field experience is embodied in every RCA television antenna.

Note 2. RCA recommends a folded dipole (205A1) for the high-band antenna because the high-band (7-13) occupies a much smaller percentage of bandwidth than the low band (2-6): The impedance and other characteristics of a correctly-designed high-band antenna do not change greatly throughout the high band.

Note 3. Reflections on stations in different directions. In areas where reflections are prevalent and there are several stations in different directions, the technician has the

	IN SAME DIRECTION	IN DIFFERENT DIRECTIONS	IN OPPOSITE DIRECTIONS
STATIONS IN BOTH HIGH AND LOW BANDS	Combinations of 206A1, 204A1, 208A1, 205A1	Two-204A1+ Two-205A1	212A1 (Note 5)
STATIONS IN LOW BAND ONLY†	204A1+ 208A1	Two-204A1 Two-208A1	212A1 (Note 5)
STATIONS IN HIGH BAND ONLY	Two-205A1	Two or more 205A1	Two or more 205A1

**In strong signal areas where outside antennas cannot be installed, Indoor Television Antenna 202A1 is recommended.*

†In areas with a single station in the low band, one or more folded dipole/reflector antennas cut to frequency is recommended, depending on signal strength.

choice of the following antenna arrangements:—

A. Use a high-low combination (205A1 plus 204A1) in locations where the low band stations and one or more of the high-band stations are located in a different direction from other high band stations. Phasing between the two antennas is important in minimizing reflections. Follow the phasing instructions furnished with the antenna.

B. Use the high-low array 206A1 in locations where the high-frequency stations are in a different direction from the low-frequency stations.

C. Use a high-low antenna (204A1, or 206A1 or 204A1 plus 205A1) in conjunction with a suitable antenna rotating motor.

D. Use a separate antenna and transmission line for each station, with a switch at the receiver to select the desired antenna. Position and orient each antenna for least reflections. Space the transmission lines at least six inches from each other to minimize intercoupling.

When reflections are coming from the rear, the antenna should have good front-to-back ratio to minimize the reflections. The front-to-back ratio of a plain or folded dipole and reflector is best at the resonant frequency and becomes worse at frequencies above resonance. For example, an antenna and reflector cut for channel 2 may have a front-to-back voltage ratio of 4 to 1 on channel 2, but only 1 to 1 on channel 6. On high-band antennas, cut for channel 7, the front-to-back ratio remains nearly constant because the percentage of frequency increase from channel 7 to 13 is only about 23%, compared with 60% from channel 2 to 6.

To minimize rear reflections on a single low-band channel, use an antenna and reflector resonant at the picture-carrier frequency of the particular channel.

Note 4. Low-band stations or high band stations in different directions. In areas where reflections are prev-

alent and there are several low-band or several high-band stations in different directions, it may be necessary to use a suitable antenna rotating motor, or else a separate antenna and transmission line for each station.

Note 5. RCA-212A1 reversible beam antenna array for use between two TV areas has high front-to-back ratio on all channels. The RCA-212A1 is designed primarily for locations between two cities where reception may be obtained from the TV stations in both cities. The 212A1 has high front-to-back ratio to minimize interference from opposite stations transmitting on the same or adjacent channels, and to reduce reflections.

The 212A1 has lobe switching: The receiving lobe may be shifted 180 degrees by means of the switch of the diplexer which is mounted on the rear of the TV receiver. The diplexer is furnished with the antenna.

The 212A1, developed by RCA Laboratories in Princeton, N. J., gives excellent performance in those areas for which it was designed. For example, in Princeton, which is between New York and Philadelphia, it is possible with the 212A1 to receive all of the New York stations, all of the Philadelphia stations, and some of the stations in Baltimore and Washington, with complete freedom from "window-wiper" and "venetian blind" interference normally produced by stations on the same or adjacent channels in two different TV areas.

In locations where stations are in opposite directions, but where there is no need for high front-to-back ratio, two separate antennas may be used. Orient the antennas in opposite directions and use separate transmission lines with a selector switch at the receiver. Or use one antenna with a suitable antenna rotating motor. Select appropriate types of antennas from the accompanying table.

(Continued on Page 7, Column 3)

STRONG AND MEDIUM SIGNALS*

	IN SAME DIRECTION	IN DIFFERENT DIRECTIONS	IN OPPOSITE DIRECTIONS
STATIONS IN BOTH HIGH AND LOW BANDS	204A1 (Note 1)	206A1 or 204A1+ 205A1 (Note 3)	206A1 or 204A1+205A1 or 212A1 (Note 5)
STATIONS IN LOW BAND ONLY†	204A1 (Note 1)	204A1 (Note 4)	Two-204A1 or 212A1 (Note 5)
STATIONS IN HIGH BAND ONLY	205A1 (Note 2)	Two-205A1 (Note 4)	Two-205A1

SNUG-FIT CARTON PROTECTS RCA's ONE-HIGH QUALITY

**New Packaging Technique Protects The
Tube From Factory to User**

One of the most important tube-packaging developments in recent years—the “snug-fit” carton—has been announced by RCA. Affording greater protection for the tube, new ease of identification, and more attractive overall appearance, the new carton is rapidly being adapted for all RCA, Cunningham, and RCA Victor receiving tubes.

Most important feature of the new “snug-fit” carton is the conical-shaped sleeve into which the tube is inserted by hand, thus assuring a firm snug fit unobtainable with other methods.

As an additional feature, the new carton features large, highly-readable type numbers printed on a large white panel on the end of the carton to aid distributors and dealers in selecting desired tube types at a glance.

Shake the new “snug-fit” carton! Compare it! You'll notice the difference. RCA packages are of the same

quality as the merchandise they box. It is your assurance that RCA's One High Quality, so carefully built into every tube at the factory, remains there to serve your customer. It means you can install an RCA, Cunningham, or RCA Victor in a receiver with full confidence of customer satisfaction.

Miniature and GT tube types will be the first to be packed in the new carton. Other types will be so packed as soon as deliveries permit. Watch for RCA, Cunningham, and RCA Victor tubes in their distinctive new snug-fit cartons.



WHAT IS A ? CUSTOMER

A customer is the most important person ever in this office—in person or by mail.

A customer is not dependent on us—we are dependent on him.

A customer is not an interruption of our work—he is the purpose of it. We are not doing him a favor by serving him—he is doing us a favor by giving us the opportunity to do so.

A customer is a person who brings us his wants. It is our job to handle them profitably to him and to ourselves.

A customer is not an outsider to our business—he is a part of it.

A customer is not a cold statistic—he is a flesh-and-blood human being with feelings and emotions like your own, and with biases and prejudices.

A customer is not someone to argue or match wits with. Nobody ever won an argument with a customer.

— PAUL T. BABSON

From "The Scratch Pad," Sales Management Magazine

TRY THIS UNIQUE PROMOTION YOURSELF!

FOR FINER REPRODUCTION OF MUSIC

CALL _____

OR 3-2689

W. STUEDEMAN

1 NO. HARRISON ST., EAST ORANGE

Here is the novel change card devised by W. Stuedeman of East Orange, New Jersey. A few of these cards filled with change for a dime or a quarter, and kept in the cash register, have turned a burden to a boon for this service dealer.

"CHANGE STATION" COMBINES SERVICE AND PROMOTION

In this modern day and age hardly a city or suburban area is without a parking toll meter for the automobile. Time and again, merchants along these routes have been hounded by motorists seeking change to feed these hungry machines. Here is how an East Orange, New Jersey radio service dealer turned his burden into a real business aid.

Devised by Mr. W. Stuedeman, who operates a radio and electronic service store at 1 North Harrison Street, in East Orange, it consists only of a simple business-type card with slots cut in it for the insertion of nickels and dimes. Whenever a frustrated shopper dashes in for change in an effort to beat the return of the local constabulary, Mr. Stuedeman has a ready answer and a smile. He simply dips into his cash register for a card bearing a dime or a quarter in change as the case requires. Naturally the card contains a brief message promoting Stuedeman sales and service.

To back up this novel scheme, a small card has been placed in front of his window announcing the fact that this is a "Parking Meter Change Station." Curiosity aroused by such a sign has often brought even passing shoppers in for change. These cards have paid off in added business.

RCA DIRECTORY OF TV COMPONENTS

**New Folder Now Available
At Your Local RCA Distributor**

Time saved is profit made! The popular RCA Component Directory for television receivers booklet, Form No. SP-1006, places right at your finger tips the major component replacements for 214 television sets of 38 manufacturers. It quickly directs you to the quality-built RCA part you need.

Components are grouped according to receiver make and model number. Each component is listed in alphabetical sequence with its stock or part number and the corresponding RCA type number. From this cross reference choose the RCA components from your stock and be assured of a service job done with quality parts.

RCA's Component Directory is a sure way to cut down on your servicing stock of TV Components. Keep this reference handy and concentrate your stock on RCA's famous line of original television components.

SUGGESTED LIST PRICES OF RCA KINESCOPES

The following suggested list prices on RCA Kinescopes reflect recent price revisions. Substantial reductions have been made possible by improved production methods and techniques, and, in line with RCA's policy, these savings are passed on to the service dealer and his customers.

Tube Type	Suggested List
3KP4	\$18.00
5BP4*	27.50
5TP4	54.60†
7DP4	29.75
7JP4	22.50
9AP4*	72.00
10BP4	34.75†
12AP4*	82.50
12LP4	43.00†
16AP4	74.50

*Pre-war Types

†Recent Price Revision

TELEVISION SERVICE

By John R. Meagher
Television Specialist, RCA Renewal Sales

PART VIII Vertical Oscillator Troubles

In a previous article dealing with vertical deflection troubles, it was pointed out that when the vertical oscillator fails to operate there is no vertical deflection. It was shown that this trouble is evidenced by a single bright horizontal line on the kinescope.

When the output of the vertical oscillator is weak it may be impossible to obtain sufficient height with good vertical linearity. The activity of the vertical oscillator can be checked quickly and easily by measuring, with an RCA Volt-Ohmyst*, the developed negative bias on the grid of the oscillator tube. The use of an electronic voltmeter such as the Volt-Ohmyst is necessary because it does not affect the operation of the oscillator circuit. In a circuit such as that given in Fig. 1, the developed bias can be measured between the grid of the oscillator tube and the junction of the vertical-hold control and the 2.2-megohm resistor.

A further trouble in the vertical oscillator is incorrect frequency. The impossibility, by careful adjustment of the vertical hold control, of getting one (and only one) complete picture from top to bottom, is a reasonably definite indication that the frequency, or blocking rate, of the vertical oscillator is either too high or too low. The correct frequency is 60 cycles per second.

Effects of various incorrect frequencies are shown in the accom-

panying photographs. In each of the cases pictured here, the vertical hold control was adjusted to obtain a stationary pattern. At other settings of the vertical hold control, the picture rolls up or down.

There is frequently confusion as to whether troubles such as those illustrated here are due to faulty sync, or to incorrect frequency of the vertical oscillator. A decision can be made quickly by "killing" the sync and "free-wheeling" the vertical oscillator, as follows:

1. Remove the sync input to the vertical oscillator. One way to do this is to open the coupling capacitor from the sync section. This capacitor, as shown in Fig. 1 at left side is 0.01 uf in value.
2. Slowly adjust the vertical hold control. If at some critical setting it is possible to obtain one (and only one) complete picture from top to bottom, and hold it almost stationary by careful adjustment of the control, it is a definite indication that the frequency of the vertical oscillator can be adjusted correctly. Naturally, the hold control in this case should not be too near the extreme end of its range because there may not



Fig. 2—The presence of two complete pictures indicates that the electron beam in the kinescope is being deflected from top to bottom in 1/30th second, or that the frequency or blocking rate of the vertical oscillator is 30 instead of 60 cycles per second. This condition was produced by increasing the value of the 1.5-megohm resistor in the oscillator grid circuit to 3 megohms, and by adjusting the vertical hold control to obtain a stationary picture. This effect is accompanied by flicker and lack of interlace.



Fig. 3—The presence of three complete pictures indicates that the electron beam in the kinescope is being deflected from top to bottom in 1/20th second, or that the frequency or blocking rate of the vertical oscillator is 20 instead of 60 cycles per second. This condition was produced by increasing the value of the 1.5-megohm resistor in the oscillator grid circuit to approximately 6 megohms and by adjusting the vertical hold control to obtain a stationary picture. This effect is accompanied by flicker and lack of interlace.

be enough range of adjustment when sync is again applied.

3. If it is not possible to obtain one complete picture at any setting of the vertical hold control, it is a definite indication that the frequency of the vertical oscillator cannot be adjusted to the correct rate of 60 cycles per second. If the reader studies the accompanying photographs and explanations he should have no difficulty in recognizing and understanding the symptoms of incorrect vertical frequency.

Once more we wish to remind the reader that an exclusive collection of photographs, representing a cross-section of television troubles, is available in the RCA "Pict-O-Guide," Volume I and Volume II. These photographs are printed on high-gloss stock for utmost clarity, and are bound in a durable and attractive pocket-size ring binder. The Pict-O-Guide is available only through RCA, RCA-Victor or Cunningham distributors, without extra charge, with purchase of RCA, Cunningham or RCA Victor tubes. Many thousands of these books are already giving practical aid to television technicians. The Pict-O-Guide is widely acclaimed as the clearest, simplest, most effective, and useful educational device that has ever been offered to television technicians.

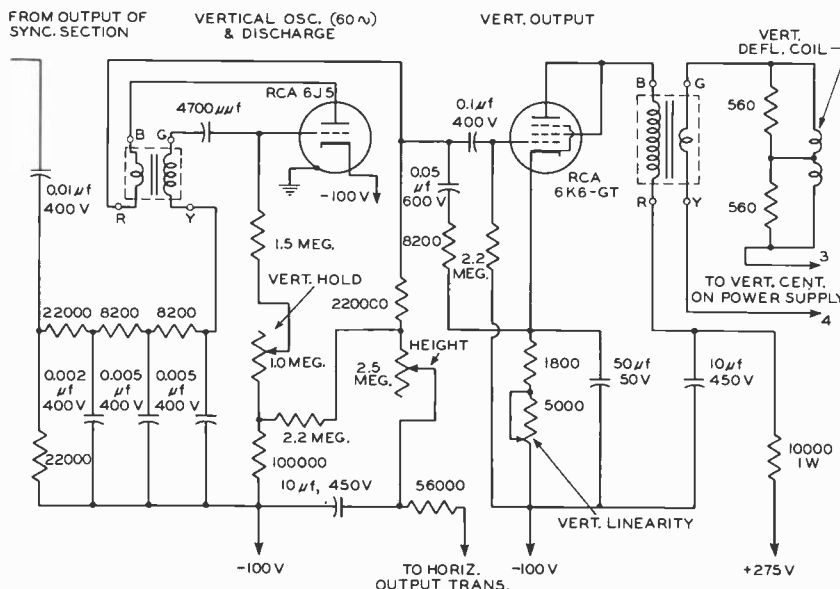

Fig. 1—Vertical oscillator and vertical deflection section of the television receiver used in producing the troubles shown in accompanying photographs. The frequency or blocking rate of the vertical oscillator is largely dependent on the RC time constant in the grid circuit. The value of resistance in the grid circuit is adjustable by means of the vertical hold control. The correct free-running blocking rate is slightly less than 60 cycles per second. Incoming vertical sync pulses serve to trigger the vertical oscillator, keeping it in step or in sync with the vertical deflection of the TV transmitter.

*Trade Mark Reg. U. S. Pat. Off.



Fig. 4—The presence of two superimposed half-pictures indicates that the electron beam in the kinescope is being deflected from top to bottom in 1/120th second, or that the frequency or blocking rate of the vertical oscillator is 120 instead of 60 cycles per second. This condition was produced by a short circuit across the 1.5-megohm resistor in the oscillator grid circuit and by adjusting the hold control for a stationary picture.

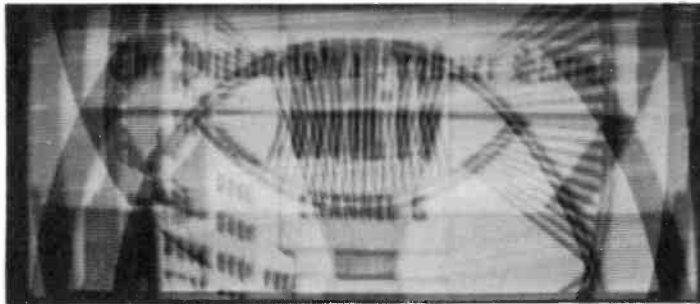

Fig. 5—Same trouble as in Fig. 4, but with the hold control readjusted for a different blocking rate. When the frequency of the vertical oscillator is either too high or too low, the effect that is seen on the kinescope varies with adjustment of the vertical hold control. Usually, the picture appears to rotate vertically except at one or more definite settings of the vertical hold control. Under some conditions of trouble, the picture cannot be held stationary at any setting of the hold control.

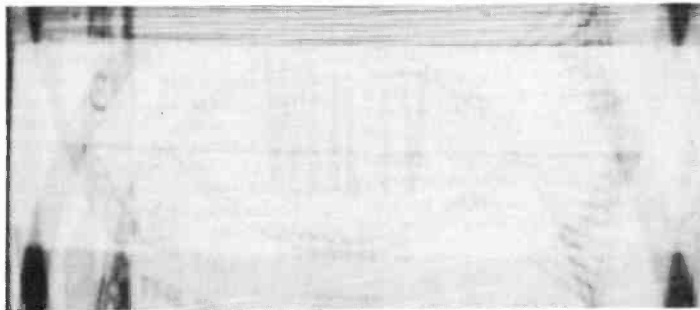

Fig. 6—Effect similar to Fig. 4 and 5, but produced by opening the 100,000-ohm resistor which is connected between the vertical hold control and the minus 100-volt bus. The effects shown in Fig. 4, 5, and 6 can be duplicated by leakage across the grid capacitor of the vertical oscillator, by a low-value grid capacitor, and by other troubles in the vertical oscillator circuit. Fortunately, the vertical oscillator and discharge circuit contains only a few components which can be checked quickly with a VoltOhmyst to locate the faulty unit.

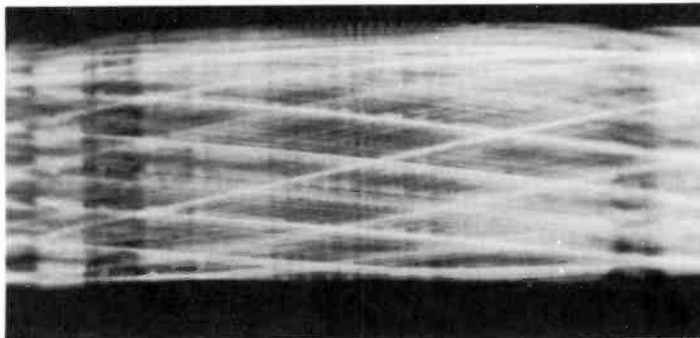

Fig. 7—The effect shown above was produced by opening either the 0.05-uf capacitor or the 8200-ohm series resistor in the plate circuit of the vertical oscillator and discharge tube. In normal operation, the saw-tooth voltage for the vertical output tube is generated across this capacitor. When the capacitor is open, the voltage on the plate of the discharge tube rises very rapidly instead of gradually. This rapid rise, and the normal rapid discharge, produces rapid vertical deflection of the electron beam in the kinescope, even if the blocking rate is correct. As a result, all of the scanning lines, which should be nearly horizontal, have a decided slope.

SALES *and* SERVICE TIPS

Once again you can win a handsome RCA Resistor-Code Pencil by sending tips to RCA Radio Service News, Harrison, New Jersey . . . All tips become the property of RCA to be used as it sees fit . . . Service Tips are our readers' ideas, not ours. While we believe they are worthwhile, we cannot be responsible for them.

APPEARANCE IS BIG SALESMAN

As important as the capability of the repair man servicing the radio, is the appearance of the set when returned. A sparkling dial and glass plus new RCA dial lamps never fails to make an impression on the housewife's eye—and helps keep me first on her list for future servicing.

H. O. Haunfelder
903 W. Eula Court
Milwaukee 12, Wis.

EXTRA SERVICE ON AC-DC RECEIVERS

Every ac/dc set coming through our shop receives an extra check for operation on dc voltage. A selenium rectifier is wired to provide 110 volts dc, enabling the set to be checked at this rating. Varying this dc voltage with an RCA Isotap reveals whether the receiver operates at maximum and minimum dc ratings.

Ben Wolf
Tremont Electrical Supply Co.
347 Tremont Street
Boston 16, Mass.

COIL DOPE PROTECTS WAXED CAPACITORS

In many small sets and television receivers, confined heat frequently melts the wax ends of tubular capacitors. Covering each end with a coating of coil dope helps keep this wax from messing up the sets and also retains the insulating properties of the wax.

J. Goldstein
151-09 34th Ave.
Flushing, L. I., N. Y.

HOT TUBES REMOVED WITHOUT BURNING HANDS

In order to remove hot tubes without the danger of burned fingers, I use a rubber sleeve taken from inside an old vibrator. The average size sleeve will fit all metal and GT types and will stretch over most larger sizes.

Don Ptomey
Rader's Appliance
2814 Jay Street
Sacramento, Calif.

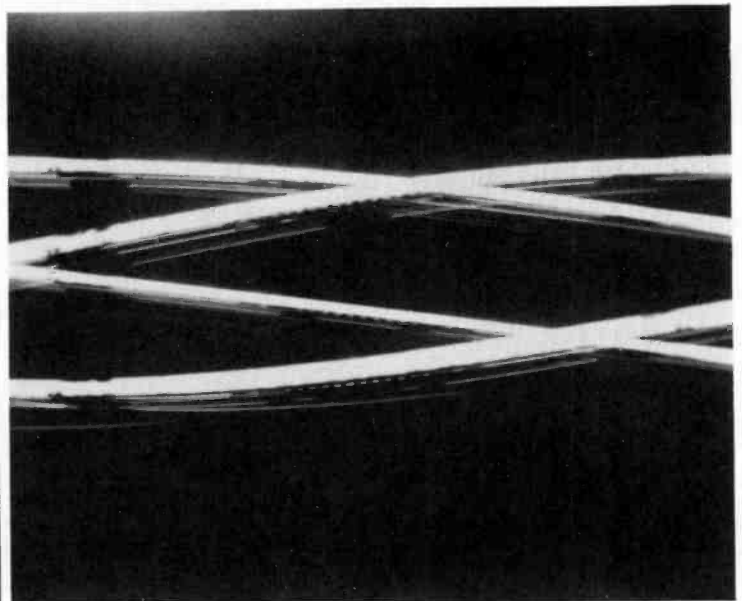

Fig. 8—Same trouble as in Fig. 7 but with a different setting of the vertical hold control. It is suggested that the reader duplicate the troubles shown in these photographs, and study the resulting symptoms displayed on the kinescope, particularly noting the wide variety of effects that are produced by adjusting the vertical hold control in each case. For classroom or other instructional purposes, the hold control and the 1.5-megohm series resistor may be replaced with a 10-megohm potentiometer to permit changing the vertical oscillator frequency over a wide range.

KINESCOPE ADJUSTMENT PROCEDURE ANNOUNCED

Faster service and an assurance of fair adjustments to the consumer result from new and more convenient kinescope procedure announced to distributors.

Here's how it works: The distributor will be supplied with an adjustment guide and a supply of tube tags. When a kinescope is returned, the distributor will fill in a tag with information supplied by the service-dealer. Part of this tag will be attached to the tube, the remainder retained for the record. To insure fast operation of this plan, it will be necessary for the service-dealer to supply this information accurately *at the time of return*. It is suggested that all concerned check with their distributor as soon as

possible, inspect this tag, and familiarize themselves with the data required.

This new procedure is another of many RCA programs designed to aid service-dealers in conducting their business operations smoothly and efficiently. Profit through this program by being in a position to render a greater service to your customers. See your RCA Distributor today. (The kinescope return tag is reproduced below—your distributor has them now).

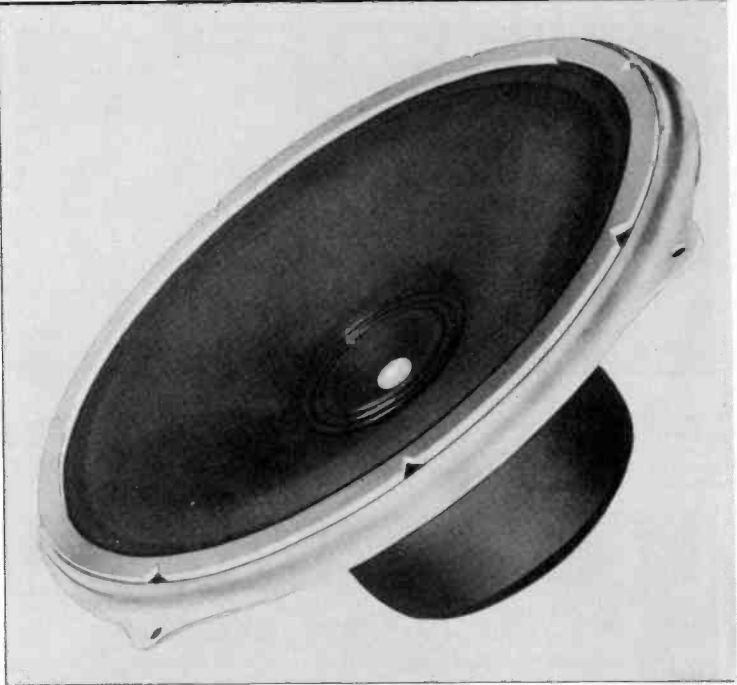

RCA KINESCOPE ADJUSTMENT REQUEST AR# 8722: RCA

TO TUBE	TUBE TYPE	SERIAL No.	BASE CODE	TUBE TYP
	DATE TUBE INSTALLED	DATE FAILED	SER-VICE	DATE TUE INSTALLE
DESCRIBE FAILURE	MONTH DAY YEAR	MONTH DAY YEAR	MO.	DESCRIBE
	I CERTIFY THAT THE ABOVE INFORMATION IS CORRECT.			DEALER
MAKE OF TELEVISION	MODEL	SIGNATURE	DATE	SIGNATU
	(FOR SERVICE DEALER)			MONTH DAY YEAR
FOR DISTRIBUTOR USE ONLY	DISTRIBUTOR	FOR DISTRIBUTOR USE ONLY		SHIPPED
	ADDRESS	CREDIT <input type="checkbox"/> REPLACEMENT <input type="checkbox"/>		ADDRESS
CITY-STATE	SHOW ADJUSTMENT DESIRED:		ADJUSTM	
	FOR RCA USE ONLY 1 2 3 4 %			

Part of the new Kinescope adjustment tag.



The RCA Battery Magic Motion Display—a real eye-catcher for your window or counter.

RCA BATTERIES (Continued from Page 1)

haven't used the RCA CARRY KIT to sell your customer spare batteries—you're missing a good bet. These Carry Kits—complete with carrying handle—sell batteries like soda pop. Your distributor has them.

To further boost sales and establish you as a supplier of RCA Batteries a special Profit Package is available through your distributor for a limited time only! Through the purchase of a new "Magic Motion" Display and \$10.13 worth of RCA Batteries, you get 38 RCA-VS036s—NO CHARGE! You recover the cost of the "Magic Motion" display—and you make your regular profit on the purchased batteries as well. Your RCA Battery distributor has complete details.

Use the RCA-VS036 as your Battery sales leader. Sell the complete RCA line. Remember, all RCA Battery Sales are directed primarily to Radio Dealers and Servicemen. Because you do not compete with non-radio outlets—repeat sales stay with you. You build your business.

GOLDEN OPPORTUNITIES

An increasingly important market is developing and promises new profits to servicemen. Consider FCC Commissioner George Sterling's recent comments on Taxi Radio. His prediction was that "within from three to five years 90 per cent of all taxicabs will be equipped with radio. The radioless cab will be as much of a rarity as the surrey with the fringe on top."

Someone is going to be called on to maintain these units. Why not you?

15-INCH SPEAKER (Continued from page 1)

Of coaxial design, the new speaker produces wide angle radiation of all frequencies from a single plane. The 515S1 has a 25-watt power-handling capability with low, non-linear distortion, and a wide frequency response of from 40 to 12,000 cycles-per-second. Its rugged mechanical design features a 2-pound Alnico V magnet.

The RCA 515S1 consists of high- and low-frequency units mounted coaxially. Over the range of crossover frequencies which is centered at 2,000 CPS, the two cone sections vibrate as a single cone, thus eliminating cross-over interference characteristics usually found in high-low combinations.

As a result, the usual elaborate crossover electrical network is not needed. In fact, only an isolating capacitor is used to prevent the high-frequency voice coil from receiving too much low-frequency energy.

For custom-built installations, or as a replacement speaker in the consoles of music-lovers, you can't beat the RCA 515S1. Hear one at your RCA Distributor's today, or ask for your copy of the folder describing this top speaker (3F620). Suggested list price of the RCA 515S1 Duo-Cone Speaker is \$52.50.

ARE YOU AN AMATEUR RADIO ENTHUSIAST?

If so, you'll want to keep up with the latest in the Ham World via RCA HAM TIPS. This popular publication is available bi-monthly from your RCA Distributor—ask him to save a copy for you.

What's New in Tubes?

NEW ADDITIONS TO THE RCA TUBE LINE

Recent additions to RCA's family of receiving tube types maintain its undisputed leadership as the trade's outstanding line. Latest listings include:

Tube Type	Suggested List
6AB4*	\$2.00
6AH6*	3.90
6BD6*	2.00
12BD6*	2.00
50C6G	2.90
50Y7GT	2.00

*Miniature Types.

These recently added types are now available at most RCA Cunningham or RCA Victor Distributors. Visit the one nearest you and be assured of Radio's Leading Line.

PRICE REVISION

The following suggested list prices reflect recent changes. Be sure to note these on your price card.

Tube Type	New Suggested List
1B3GT	\$2.65
5W4	1.65

CHANGES IN FOUR TYPE DESIGNATIONS

Four recent type designation changes are recorded here for your information and guidance. Future

price-card listing and tube data will bear only the new designation instead of the double branding. These are:

Old Type No.	New Type No.
OA3/VR75	OA3
OC3/VR105	OC3
OD3/VR150	OD3
6U5/6G5	6U5

RCA SUBMINIATURES

Four new subminiature tubes, providing a complete tube complement for very compact lightweight, portable AM receivers, have recently been announced. They are:

RCA-1AC5	Power Pentode
RCA-1AD5	Sharp-Cutoff Pentode
RCA-1E8	Pentagrid Converter
RCA-1T6	Diode-Pentode

Suggested List Price on all types is \$2.40 each.

12-INCH KINESCOPE

A twelve-inch all-glass kinescope, the 12LP4, is in mass production at RCA's plant in Lancaster, Pennsylvania. The same "One High Quality" found in all RCA Kinescopes is a prime feature of the new RCA-12LP4.

Suggested list price of the RCA-12LP4 is \$43.00.

TV ANTENNA GUIDE

(Continued from Page 2)

Note 6. Weak signal areas. In weak signal areas, one of the best methods of increasing signal strength is by stacking antennas; that is, by using two or more antennas with correct spacing, phasing, and matching—under suitable conditions two antennas provide a power gain of 2 or a voltage gain of 1.4 compared with a single antenna of the same type. A stack of 4 antennas can provide a power gain of 4 or a voltage gain of 2, etc.

In locations where the high-band stations are weak, it is advisable to stack two or more of the high-band antennas. In locations where the low-band stations are weak, it is advisable to stack two or more of the low-band antennas. The RCA-204A1, RCA-206A1, and the RCA-208A1 antennas due to their light weight, compactness, and low cost, are ideally suited for stacking.

Height of the antenna is important. With horizontal polarization, the field strength increases directly with height. Raising an antenna from 30 feet above the effective ground plane to 60 feet doubles the developed voltage in most cases.

Transmission-line losses are extremely important. Use the lowest-loss 300-ohm line, such as RCA Bright Picture Line, RCA 201A1. Many of the lower-priced imitations have appreciably higher loss. Coax, contrary to some opinions, is not a cure-all for local electrical interference in average residential installations. The higher loss in coax may far outweigh any slight improvement in reducing noise pickup.

directivity pattern. This pattern is changed to a single forward lobe by the addition of a high-frequency reflector of correct length and spacing. The long low-frequency reflector provides a forward lobe on the low-band channels.

The over-all effect of the "V" attachments and of the high-frequency reflector is to produce a single forward lobe on the high bands. The antenna, therefore, has best pickup in the forward direction on both the low and high bands.

Special harness isolates antennas in 206A1 Hi-Lo combination. A special harness of 300-ohm line cut to specific lengths is furnished with the RCA-206A1 antenna for coupling the low-frequency and high-frequency antennas to the transmission line. This harness effectively isolates the two antennas so that either one may be rotated without appreciably affecting pickup on the other. This is an important feature when it is necessary to orient each antenna separately for minimum reflections.

Under certain conditions the short open-stub section of the harness may be omitted to provide some interaction between the antennas for balancing out reflections.

Reinforcing studs in antenna elements for extra strength. In many TV antennas, the antenna elements are flattened out and drilled for attachment to the cross arm or insulator. The aluminum tubing is weakened at these points and is prone to bend and break under wind pressure and ice loading.

In RCA antennas each of the low-band elements is reinforced by a long solid stud which is used for fastening the element to the cross arm.

Straight-grain impregnated ash insulators provide strength and durability. The RCA 204A1 and 208A1 antennas have straight-grain ash insulators. Selected ash of this type has been used in hundreds of thousands of RCA television antennas. Many of the original RCA antennas, with ash cross-arms, erected during the initial RCA TV field tests in 1936 are still in excellent condition after more than a decade of exposure to the elements. Plastic type insulators are subject to cracking, breaking and deterioration under the effect of heat, cold, wind stress, and ultra-violet rays from the sun.

A full reprint of this valuable TV Antenna Selection Guide, including a detailed map of your local TV area, is now available at your local RCA Distributor. On it are also pictured the various RCA antennas referred to in the text. You'll want a copy of this Antenna Guide to aid you in your installation work—ask your distributor for a copy today.

Facts that you should know about RCA Television Antennas

"V" attachments and high-frequency reflector provide forward directivity on high band.

A dipole antenna that is 1/2-wave long at 50 Mc is 2 full waves long at 200 Mc. The directional properties of a half-wave dipole at the resonant frequency is shaped like a figure eight. The directivity pattern of the same antenna at 4 times the frequency is shaped like a 4-leaf clover, with each receiving lobe pointing about 40 degrees away from the antenna. As a result, the best pickup angle is not the same on the low and high bands. This is a disadvantage, particularly when all of the stations are in the same general direction.

The "V" attachments (short rods that jut out at an angle) on the RCA-204A1 and 208A1 antennas serve to isolate the outer ends of the antenna when a high-band station is being received. The center section, between the V's, is approximately 1/2-wave length on the high channels and has a figure eight

The Unseen Audience : : : : : By WEBSTER



Reproduced by permission of the New York Herald Tribune, Inc.

POSTMASTER: If undeliverable for any reason, notify sender, stating reason, on Form 3547, postage for which is guaranteed.

From

TO:

RADIO SERVICE NEWS

RCA RADIO SERVICE NEWS is published by the RCA Tube Department in the interest of radio servicemen and dealers everywhere. It is distributed free of charge to members of the radio-service fraternity through the courtesy of RCA and its tube, battery, test equipment and parts distributors.

T. A. 'PAT' PATTERSON --- Editor

OUT FRONT... at a new low price

10¢

SUGGESTED LIST PRICE

Sell 'em like soda pop... in the easy-to-sell, handy-to-have Carry Kit.



NOW... chalk up new selling records with the best "A" battery money can buy!

Here's selling history in the making!... RCA's famous VS036 "Sealed-in-Steel" A Battery with the special "Radio Mix" now costs no more than an ordinary flashlight cell!

Stop and think of this in terms of turnover and extra profits—and you'll agree that the RCA VS036 is today's best buy in batteries by far. Customers are quick to note the

extra listening hours they get from RCA-VS036s... actually 25 per cent more than from ordinary flashlight batteries in high-drain portables! That brings 'em back for more!

Remember, too, that you can stock up on VS036s with no need to worry about shelf life. *The RCA-VS036 stays fresh for years.*

Get sales action with the RCA "Magic Motion" illuminated display. See your RCA Battery Distributor today about the new RCA "Magic Motion" Illuminated Display expressly designed to help you sell more VS036 A batteries at the new low price. See the display in action, and you'll want one or more immediately for your window or counter.