

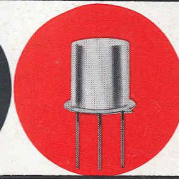

RADIO AND TELEVISION

Service News

A PUBLICATION OF RCA ELECTRONIC COMPONENTS AND DEVICES

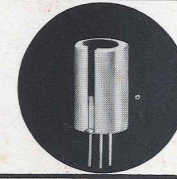
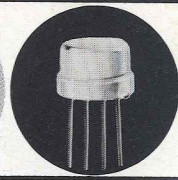
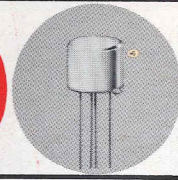
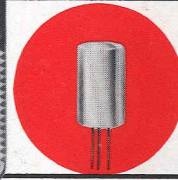
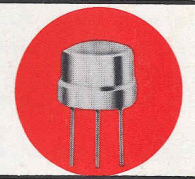
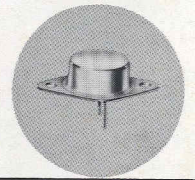

FALL
1967

Vol. 32, No. 1

RCA's New transistor tester

WT-501A Accurately Tests Transistors In-Circuit Or Out-of-Circuit at Rated Current Levels Up to One Ampere (Pages 8 and 12)

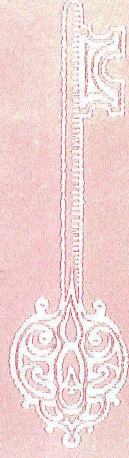

RCA's
"Gift-Time Special"
Certificates
Open Up a World
Of Great Premiums
For Holiday Gift Giving



20-546

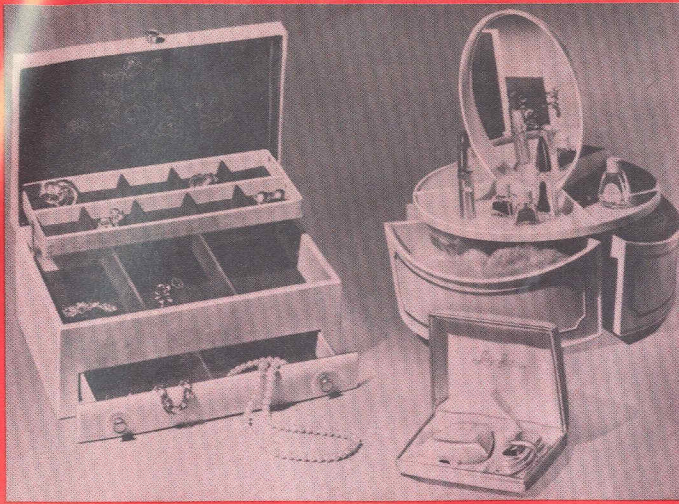

49-56

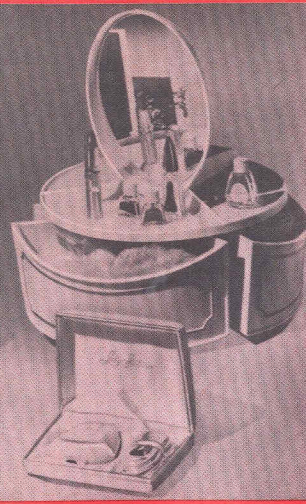

50-25

21-93

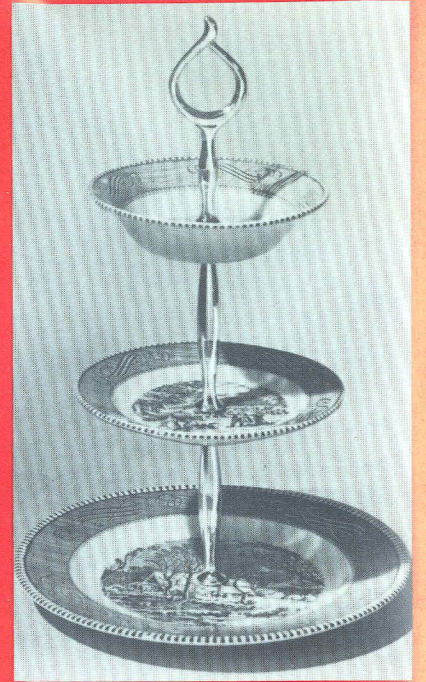

23-255



35-170



52-25

52-45

52-46

52-26

52-75

52-97

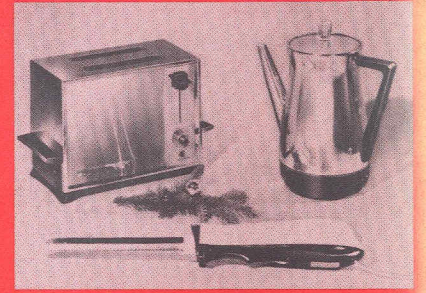

35-80

35-141

35-73

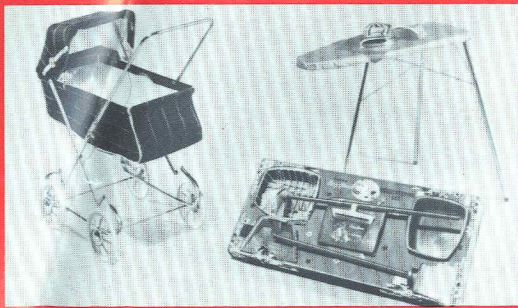

47-53

48-184

48-52

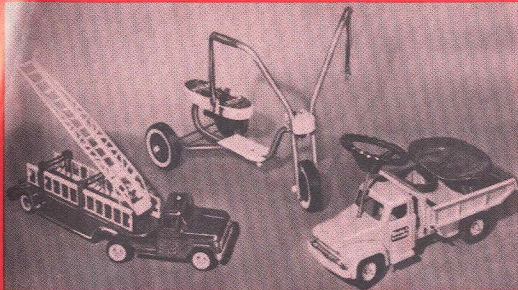

48-90

47-51

48-207

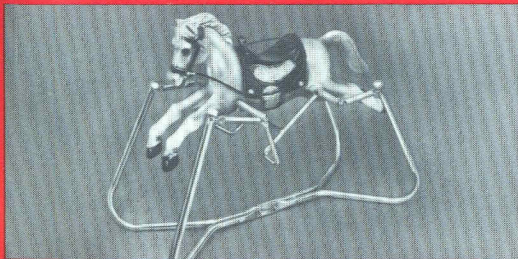

48-119



53-80

53-11

20-765



49-149

49-147

53-65

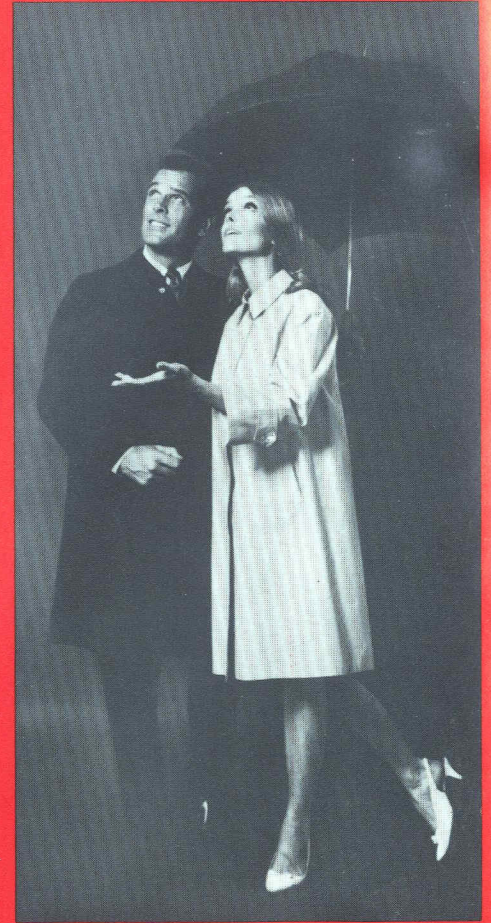

20-568

20-571

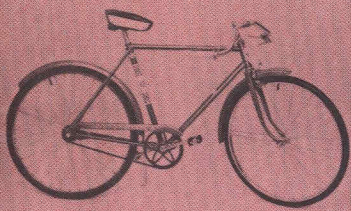

47-45

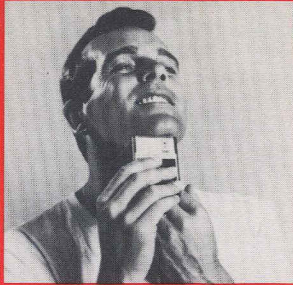

50-32



32-289-293

51-10

Any of These Exciting Premiums Can Be Yours With RCA "Gift-Time Special" Certificates

- 49-147 Lady's Twin-Pearl Ring. 39 Cert.
- 49-149 Lady's Linde Star Ring. 105 Cert.
- 53-65 Hamilton "Loralie" Lady's Watch. 133 Cert.
- 53-80 Man's Elgin "Armada" 17-jewel Watch. 61 Cert.
- 53-11 Longine-Wittnauer Man's Watch. 146 Cert.
- 20-765 Hickok Man's Alligator Belt. 36 Cert.
- 49-56 Lady's Buxton Jewel Box. 19 Cert.
- 21-93 Rubbermaid Vanity Susan. 20 Cert.
- 50-25 Lady Sunbeam Shaver. 27 Cert.
- 49-175 Marvella Simulated Jade/Pearl Bracelet. 21 Cert.
- 49-174 Marvella "Dynasty" Simulated Jade/Pearl Pin. 11 Cert.
- 49-176 Marvella Simulated Jade Earrings. 7 Cert.
- 20-412 Altman Lady's 100% Cashmere Cardigan. 61 Cert.
- 20-614 Catalina Lady's 100% Wool Jacquard Cardigan Sweater. 40 Cert.
- 20-545 Rubin Grais Lady's Hooded Corduroy Car Coat. 82 Cert.
- 35-170 Dominion Portable Hair Dryer. 40 Cert.
- 20-410 McGregor Wool Blazer. 97 Cert.
- 43-185 Underarm Portfolio. 16 Cert.
- 20-546 Rubin Grais Man's Corduroy Car Coat. 82 Cert.
- 20-319 Man's Soft Leather Slippers. 15 Cert.
- 50-32 Remington Selectro Shaver. 74 Cert.
- 20-568 Man's Alligator Raincoat. 103 Cert.
- 20-571 Lady's Alligator Raincoat. 103 Cert.
- 52-25 Sterling Silver Candlesticks. 15 Cert.
- 52-45 Star Rogers and Bros. Silverplate "Starlight" by The International Silver Company. 37 Cert.
- 52-46 Oneida 4 Pc. "Paul Revere" Coffee Service. 81 Cert.
- 52-26 Sterling Silver Salt and Pepper Shakers. 15 Cert.
- 52-75 Sterling Silver and Crystal Cake Plate. 17 Cert.
- 52-96 Reed & Barton Color-Glazed "Paul Revere" Bowl. Blue. 29 Cert.
- 52-97 Reed & Barton Color-Glazed "Paul Revere" Bowl. Red. 29 Cert.
- 52-30 Duchin Hurricane Lamps. 24 Cert.
- 29-87 "Black Forest" Cuckoo Clock. 39 Cert.
- 44-125 Twin-Candle Lamp. 25 Cert.
- 29-92 Lafayette Mantel Clock. 34 Cert.
- 52-37 Mahogany Silverware Chest. 19 Cert.

- 23-188 Pair of Wear-Ever Gas-Lite Butane Candles. 26 Cert.
- 23-255 Three-Tier Tidbit Tray. 10 Cert.
- 35-80 Toastmaster "Sovereign" Automatic Toaster. 51 Cert.
- 35-141 Rival Slimline Electric Knife. 33 Cert.
- 35-73 West Bend 8-Cup Automatic Aluminum Percolator. 27 Cert.
- 23-190 Cherrywood Salt and Pepper Mill Set. 9 Cert.
- 23-104 Deluxe Steak Platter. 9 Cert.
- 23-249 Corning Pyrex Chip and Dip Set. 11 Cert.
- 33-223 Franciscan "Apple" Earthenware Set. 63 Cert.
- 48-90 "Buddy L" Aerial Ladder Fire Engine. 18 Cert.
- 47-51 Toddler's "Tiger Trike". 16 Cert.
- 48-207 "Buddy L" Sit N Ride Truck. 19 Cert.
- 48-175 Play School Clothes Pin Dairy Wagon. 10 Cert.
- 48-159 Fisher Price School Bus. 11 Cert.
- 48-178 Hubley Transportation Set. 14 Cert.
- 47-53 Welsh Folding Doll Carriage. 18 Cert.
- 48-184 Electric Iron With Board and Pad. 12 Cert.
- 48-52 "Susy Goose" Housekeeping Set. 8 Cert.
- 48-146 Strombecker Road Race Set. 55 Cert.
- 48-200 Bossy Cow with Bell. 12 Cert.
- 48-186 Plush Teddy Bear. 8 Cert.
- 48-117 Speed King Roller Skates. 10 Cert.
- 48-192 Scrabble For Juniors. 8 Cert.
- 48-176 Brumberger Princess Phones with Push Buttons. 22 Cert.
- 47-50 Murray Boat on Wheels. 50 Cert.
- 48-137 "Kiss Me" Doll. 13 Cert.
- 48-43 Cosco Doll High Chair. 10 Cert.
- 48-139 "Drink and Wet" Doll and Cradle. 13 Cert.
- 47-20 Murray 10" Velocipede. 27 Cert.
- 48-119 Palomino Steeple-Chaser. 44 Cert.
- 47-45 "Huffy" Boy's 26" English Type Bicycle. 144 Cert.
- 47-46 "Huffy" Girl's 26" Bike. 144 Cert.
- 51-126 Argus Electromatic Slide Viewer. 43 Cert.
- 51-170 Polaroid 215 Color-Pack Camera. 155 Cert.
- 51-174 Polaroid Flash Gun Attachment. 22 Cert.
- Ebonite "Tornado" Bowling Ball.
- 32-289 a. Lady's 12-Lb. Ball. 52 Cert.
- 32-290 b. Lady's 14-Lb. Ball. 52 Cert.
- 32-292 c. Man's 15-Lb. Ball. 52 Cert.
- 32-293 d. Man's 16-Lb. Ball. 52 Cert.
- 51-10 Wide-Angle Binoculars. 102 Cert.

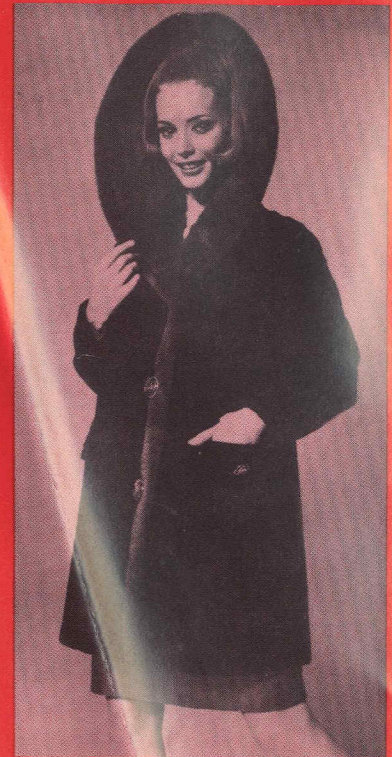

20-545

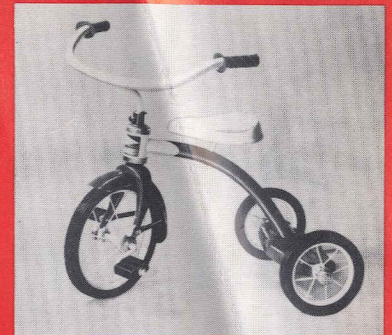

47-20



51-126 51-174 51-170



29-92

44-125

Get on Board



Valuable Certificates With Purchases Of RCA Entertainment-Receiving Tubes
From Participating RCA Distributors Entitle You to Choice
Of More Than 70 Exciting New Premiums



With the rapidly approaching holidays signaling a new round of last-minute rush and indecision for many shoppers, what better relief for your own gift-giving needs than a ready-made selection of quality items from RCA — *FREE from participating RCA distributors with your purchases of RCA entertainment-receiving tubes!*

Here — for your convenience and economy — are more than 70 useful and attractive premiums, all featured in special gift categories that excite immediate interest and appeal for every family member. These categories include men's and ladies' jewelry and accessories; men's and ladies' wearing apparel; fashionable tableware and furnishings for the home; children's toys; and items for hobbyists.

All come your way aboard "RCA's Gift-Time Special" — a dynamic new premium program now being extensively promoted by RCA and its participating distributors from coast to coast.

The complete story of this appealing offer is told in a 12-page flyer (1A1675) specially prepared to present you with a full description and illustration of each item in vivid, true-to-life color. If you haven't had the opportunity to examine this flyer, ask your local participating RCA tube distributor for a copy as soon as possible.

Your "reservations" aboard "RCA's Gift-Time Special" are quickly confirmed through the free "Gift-Time Special" certificates which you receive with your purchases of RCA entertainment-receiving tubes. Check the flyer

for the number of certificates required for the gifts you wish to earn. When you have acquired the necessary number, fill out the order form on the inside back cover of the flyer and mail with the certificates to the address shown in the form. The premiums of your choice will then be shipped directly to you.

RCA's "Gift-Time Special" certificates are valid for redemption until midnight of June 30, 1968, and valid for use only in the U.S.A. (except where prohibited, taxed, or restricted).

For new horizons in practical gift-giving and holiday enjoyment, contact your local participating RCA tube distributor for the details of this exciting premium program at your earliest opportunity.

With Your Purchases of RCA 21-Inch Color-TV Picture Tubes...

LIFE Science Library

SPECIAL OFFER ON



COLOR PICTURE TUBES

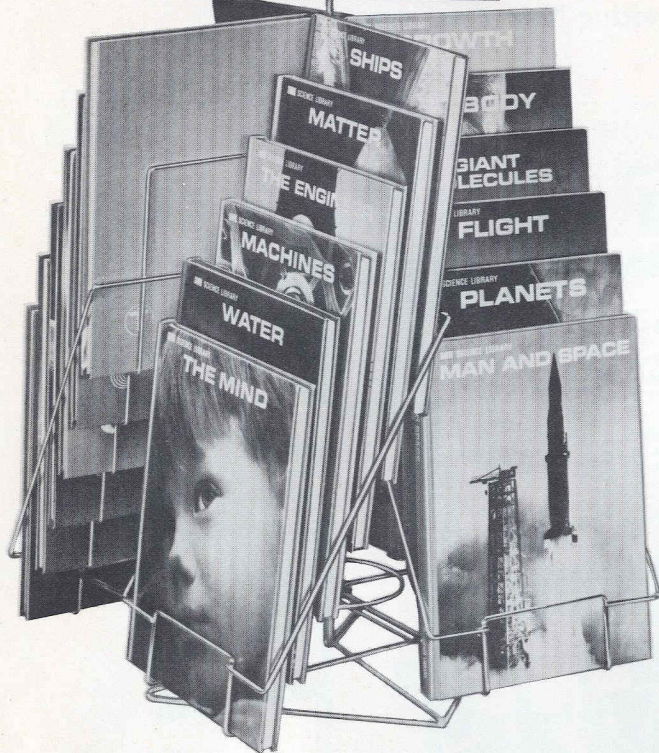

'Volumes of Value'

Select This...

Fascinating Reading
For You and Your Family
Through the Famous
LIFE Science Library

Or This!

Your Choice From
The Entire Catalog
Of Van Heusen®
Permanent-Press Shirts
For Men and Ladies

**The
Best of
Van Heusen®**
Vanopress™ Collection



Here's a dealer's choice that gives you a winning hand any way you play it!

Exciting journeys into the worlds of Science and Fashion are yours for family enjoyment through "Volumes of Value" — RCA's featured premium program for replacement-type color-TV picture tubes.

Your purchase of any RCA 21-inch color picture tube (other than color test tubes) entitles you to receive — *at no added charge* — either one of the following premiums:

- Two selections from the LIFE Science Library
- One gift certificate redeemable for any item in the "Best of Van Heusen" shirt catalog.

Choose Any of These
Great Books Featured in
The LIFE Science Library

Matter	Man and Space
Energy	The Scientist
Water	Health and Disease
Drugs	The Physician
Flight	The Engineer
Ships	Food and Nutrition
Time	Sound and Hearing
Growth	The Planets
Wheels	Giant Molecules
Weather	Mathematics
Machines	The Body
The Cell	The Mind

Naturally, there's no limit to the number of times you can earn either premium. Any purchase of an eligible 21-inch color-TV picture tube from a participating RCA tube distributor up to the closing date of January 31, 1968 immediately opens the door to these outstanding gifts.

LIFE Science Library
Enhances Family Education
And Reading Enjoyment

With today's science-oriented education placing such stringent demands on children and adults alike, RCA feels it both timely and appropriate to offer you an opportunity to own any or every volume in the famous LIFE Science Library.

Widely acclaimed by educators and eagerly absorbed by readers of all age groups, this 24-volume collection explaining the marvels of modern science has been compiled and organized to simplify and dramatize the fascinating story of Man and his environment.

Here are prized educational works so interesting and readable as to make the process of learning a recreational pastime. Each hardbound book comprises about 200 pages — 35,000 words of text — and hundreds of drawings, photographs, charts, and diagrams — many in full color. Beautifully matched to provide an attractive, readily available source of concise information on virtually every scientific subject, these volumes cover a total of 24 fascinating fields.

Whether you earn only two books or accumulate the entire Library, you'll be receiving a gift that will become a valued family possession.



The Life Science Library comprises 24 volumes such as the one pictured here. In these volumes, the complex world of Science is made thoroughly understandable and enjoyable for readers of any age group who have an interest in the subjects covered. Adults, as well as children, can profit from having these exceptional books readily available.

**Van Heusen "Vanopress"
Shirtwear Styled
For Elegant Living**

Permanently pressed the day they are made, *Vanopress*™ shirts *never need pressing again!*

Here — in the 20-page "Best of Van Heusen" catalog — is an entire collection of quality men's and ladies' styles for every occasion. You can choose from among long- and short-sleeve dress shirts; long- and short-sleeve sports shirts; and knit shirts — all offered in a vast variety of design, cloth, and color to meet every special need and taste. And for the ladies, a vast assemblage of styles from the famed "Lady Van Heusen" collection — in a multitude of smart styles and colors.

If you haven't had the opportunity to examine the "Best of Van Heusen" catalog for yourself, ask your RCA tube distributor for a copy as soon as possible. Once you see the tremendous array of styles to choose from, you'll realize what a real value this offer brings you.

**Here's All You Do to Order
Your Valuable Premiums**

Until the termination of this special premium offer on January 31, 1968 — every carton containing an RCA 21-inch color picture tube will include a

"Volumes of Value" coupon along with the customary Warranty Registration Card.

Complete the registration postcard section of the Warranty Card, as you normally would, and fill out the "Volumes of Value" coupon specifying your choice of premium. Mail *both* the card and coupon to the address shown on the Warranty Card.

If you prefer the two-book selection from the LIFE Science Library, be certain to clearly check off the volumes you wish to receive, and print your address plainly. This portion of the coupon will become the shipping label for the books you ordered. Allow three weeks for fulfillment of your request.

If you prefer Van Heusen shirtwear, you will receive from RCA a special gift certificate which entitles you to make a selection of any shirt in the catalog. You then complete the order section of this certificate and mail it directly to Van Heusen. The Van Heusen Company will forward your shirt promptly upon receipt of the order.

That's all there is to it. Here is not one but *two* exciting premium offers joined together for handy use during the forthcoming holiday gift-giving season. Remember — there's no limit to the number of gifts you can earn, so each time one of your service customers needs a replacement color-TV picture tube — *think RCA!*

Announcing Two Important New Test Instruments For Service, Industrial, and Lab Applications

In-Circuit/ Out-of-Circuit TRANSISTOR TESTER WT-501A

New convenience and efficiency in the testing and troubleshooting of transistor circuitry is introduced in the RCA WT-501A — a battery-operated, completely portable transistor tester that can measure “beta” at the current level appropriate to a particular transistor.

The RCA WT-501A is designed to test transistors accurately both in-circuit and out-of-circuit. Applications ranging from a quick check of DC beta to an extensive analysis of transistor performance make this versatile instru-



ment valuable for use in the service shop, factory, or laboratory.

The WT-501A tests transistors out of circuit for DC beta — from 1 to 1,000 — collector-to-base leakage (I_{CBO}) as low as 1.0 microampere, and collector-to-emitter leakage (I_{CEO})

from 20 microamperes to 1 ampere. Reliable in-circuit testing of transistor-current gain is made possible by special low-resistance circuitry.

The collector current (I_C) is continuously adjustable — from 10 microamperes to 1 ampere — so that both low-power and high-power transistors can be tested. If desired, a complete DC Forward Current Transfer Ratio Curve (beta vs. collector current) can be plotted. The front-to-back ratio of diodes can also be checked at various current levels.

Two sockets are provided on the panel: one socket for NPN transistors and the other for PNP transistors. This feature permits convenient transistor matching for complementary symmetry applications. Three color-coded test leads are provided for in-circuit testing, or for use with transistors that do not fit the panel socket.

Additional features include color-coded panel for simplified operation and mirror-scale meter to eliminate inaccurate reading due to parallax.

All-Solid-State Battery-Operated VOLTOHMYST® WV-500A

A long-standing reputation as one of the most popular VTVM's on the market has made the exclusive RCA VoltOhmyst® a familiar byword with technicians everywhere. Now — taking another giant step forward — this famous instrument “goes all-solid-state” in a brand new version designated the WV-500A.

If you're the impatient type when it comes to instrument warm-up time — or you find that the “zero-shift” you've encountered in tube-operated voltmeters gets on your nerves — then the time is ripe for you to consider the battery-operated, completely portable WV-500A as a “must” item on your equipment list.

The RCA WV-500A VoltOhmyst measures DC voltages from 0.01 to 1,500 volts; AC (rms) voltages from

0.2 to 1,500 volts; AC peak-to-peak voltages from 0.5 to 4,200 volts; and resistance values from 0.2 ohm to 1,000 megohms.

Seven overlapping ranges are provided for AC rms and resistance measurements, and eight ranges are provided for DC measurement — including a 0-to-0.5-volt range. Accuracy for the DC and AC rms functions is $\pm 3\%$ (of full scale reading).

An input resistance of 11 megohms on all DC ranges prevents overloading the circuit under test. The 11-megohm input resistance has the advantage of not being so high as to impair the stability of the instrument. In short, it does everything the world-famous Senior VoltOhmyst does.

Special solid-state circuitry is used in the WV-500A to assure stable, drift-free operation with minimum effect due to temperature variation. Advantages of solid-state construction include the elimination of warm-up time, and a reduction in zero-shift that can occur in tube-operated voltmeters.

The meter movement of the WV-500A is electrically protected against burnout. Provisions for zero-centering of the meter pointer contribute a useful feature for applications such as check-

ing for discriminator alignment. Circuit design permits measurement of the AC component of a DC voltage or the DC component of an AC signal. In addition, there is no DC loading effect when the instrument is used to measure AC voltages.

All measurements on the WV-500A are made with the WG-410A single-unit probe with shielded cable, which is furnished with the WV-500A along with four batteries. This probe is quickly adapted to either DC measurement or AC and resistance measurement by a convenient built-in switch.

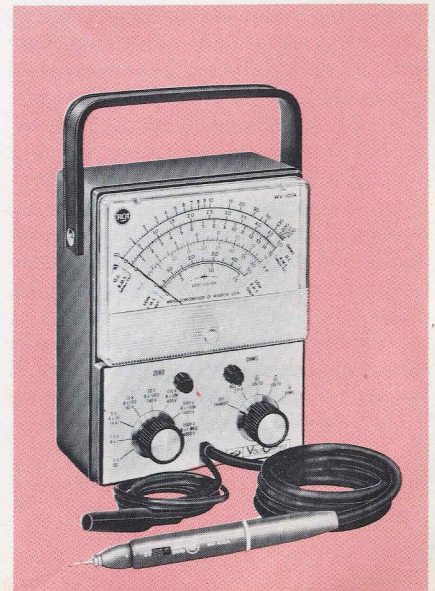

High Stability and Low Distortion Featured in RCA's New All-Solid-State Sine/Square Wave Audio Generator



The same outstanding performance characteristics which achieved such wide popularity for the RCA WA-44C Audio Signal Generator are increased to even higher capability in a new, all-solid-state version designated the WA-504A Sine/Square Wave Audio Generator. This instrument joins the WA-44C to offer the service technician broader choice in his selection of equipment for impedance and frequency-response measurements.

New solid-state circuit design of the WA-504A employs two diodes and six transistors — including an MOS transistor — to produce a stable signal with an amplitude variation not exceeding ± 1.5 db. Total harmonic distortion of the sine wave is less than $\frac{1}{4}$ of 1%.

The instrument provides a tunable sine or square wave audio-frequency

signal ideally suited for service, industrial, and educational applications. The frequency range extends from 20 Hz to 200,000 Hz. Among the principal uses of the WA-504A are the direct measurement of frequency response characteristics of audio amplifiers; testing speakers and enclosures; and determining the impedance of LC combinations.

Operation of the WA-504A is straightforward. The frequency is selected with the Frequency Range switch and the convenient single-scale tuning dial. The type of output, sine wave or square wave, and the range of output level are selected with the Output Switch. The output level can be further adjusted with the Output Level Control. The instrument has an attached shielded output cable.

RCA Power-Line Monitor Now Available in 200-280 Volt Version

The importance of knowing power-line voltage during all phases of TV servicing, test instrument calibration, and operation of electronic equipment has been vividly demonstrated by the wide use and demand for the RCA WV-120A Power-Line Monitor.



To extend the serviceability of this type instrument into the realm of higher AC line voltages, RCA now announces the WV-503A, which will provide coverage in the range of 200 to 280 volts, 25 to 400 cycles.

The new RCA WV-503A Power-Line Monitor provides a continuous, accurate indication of AC line voltage at a glance, without the inconvenience of handling probes and switches or the necessity of selecting one of several scales to determine the proper meter reading.

Used in conjunction with a variable isolation transformer, the WV-503A is a valuable aid in selecting line voltages for any equipment that requires a known line-voltage supply. It can be used on AC power-line sources with

frequency of 25 cps, 50 cps, 60 cps, or 400 cps. The instrument features accuracy of $\pm 2\%$ at 240 volts and $\pm 3\%$ at 200 volts and 280 volts when operated in temperatures from 50 to 75 degrees Fahrenheit.

The meter movement in the WV-503A is a *moving-vane* type. This type of meter indicates rms values even when the waveform of the power-sup-

ply voltage is distorted. Because meter movement is only slightly damped, resultant fast response permits the meter to indicate the presence of line-voltage "bounce" or fluctuations. Meter legibility is exceptional, with expanded scale and large voltage designations — as well as a wide pointer — enabling readings to be made at a considerable distance from the instrument.

New High-Voltage Slip-On Probe Designed for Easy Use With WG-410A or WG-299D AC/DC Ohms Probes

The RCA WG-411A Slip-On
High-Voltage Probe



Extends DC Voltage Range
Of VoltOhmysts to 50,000
Volts When Used With
WG-206 Multiplier-Resistor

New RCA Literature for Service Technicians

Time is money — and the total time you save by having the right product or service information at hand when you need it can represent an important source of profit.

Service-oriented literature from RCA, pinpointed to your practical needs, is designed to provide you with fast, accurate answers to your work problems — thereby increasing your own self-assurance as well as customer confidence in your technical ability.

Here are three recently announced RCA product guides that add another rich source of timely data to your reference files.

- **RCA HI-LITE Color Picture Tube Brochure (1D1304).** Are you up to date on the latest developments that have made *HI-LITE* RCA's *brightest color tube ever*? Have you learned about the brightness benefit of RCA's new rare-earth red phosphor . . . the efficiency of "Unity Current Ratios" . . . the operating advantages of *Perma-Chrome* shadow-mask assembly?

All of these advancements are tremendously important to you as a service technician and businessman, for they can help you explain to your customers why RCA HI-LITE is the tube that offers unmatched dependability for television viewing.

The complete story of these new de-

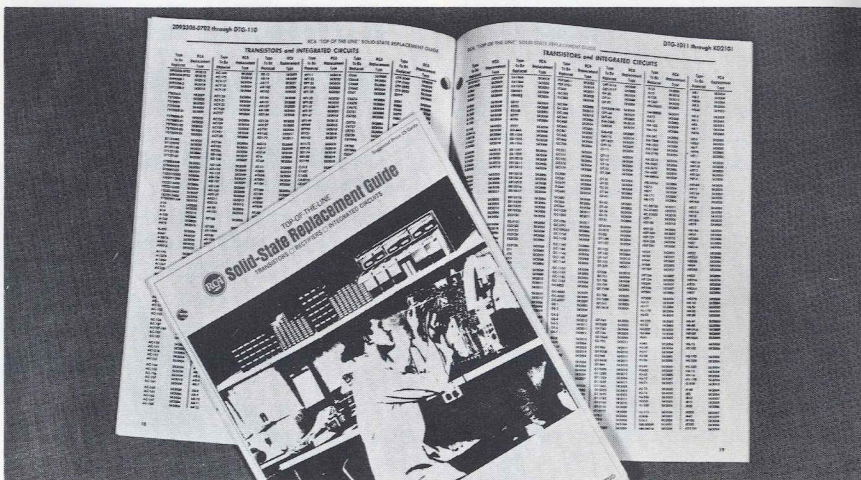
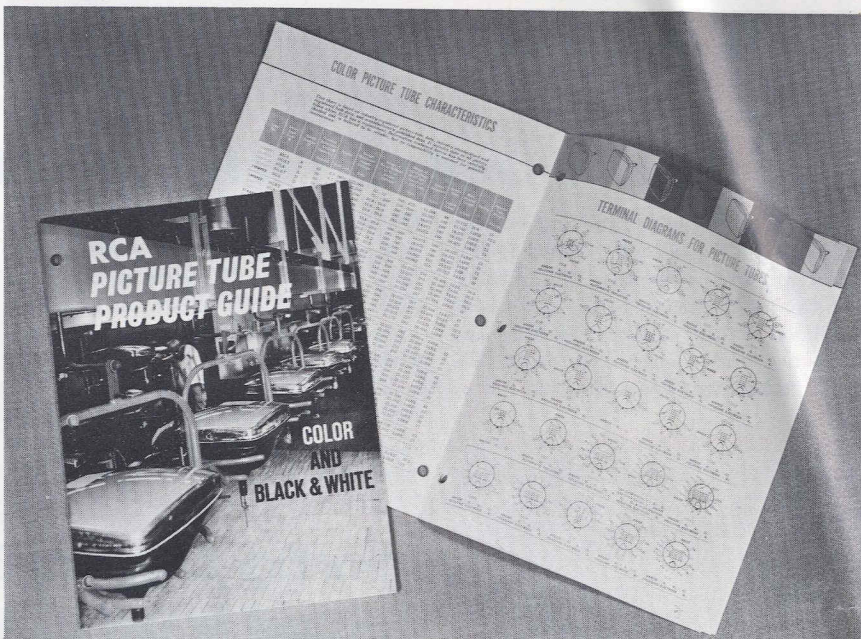
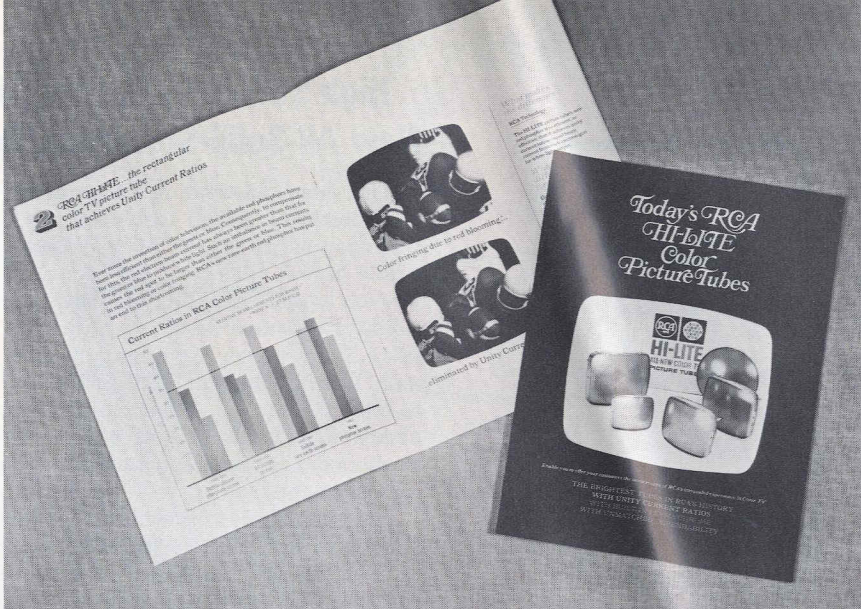

velopments has been assembled in a handsome 12-page brochure that includes detailed diagrams, charts, and illustrations in full color. This brochure tells how RCA experience, investment,

and engineering skills have resulted in the new HI-LITE tube surpassing all previous RCA color tubes by 40% in red-field brightness; 20% in the brightness of picture-tube whites; and 38%

in highlight brightness. Here, also, is the story of how RCA's new rare-earth red phosphor has put an end to color fringing due to "red blooming" – and how RCA temperature-compensating shadow-mask construction eliminates the detrimental effects of movement due to thermal expansion, and locks-in the register of the electron beams and phosphor dot trios from the moment of "picture on."

If you haven't already obtained your copy of this fascinating brochure, or would like an extra copy to carry in your tube caddy, contact your RCA picture tube distributor for the particulars.

• **RCA Picture Tube Product Guide (PIX-300B).** In this attractive new 24-page product guide is detailed RCA's complete line of color and black-and-white TV picture tubes. Here is up-to-the-minute technical information every service-dealer needs to know about RCA picture tubes – all in a single, convenient source.

A comprehensive "Characteristics Chart" covers all industry types for which RCA offers a replacement – some 563 types in all. A separate chart covers "Industry Replacement and Interchangeability" information on this same number of tube types.

Of special interest is the pictorial diagrams depicting the various types of safety features used in picture tube construction. This newly added section makes the PIX-300B of extra value to the technician at the service bench as well as to all outside service technicians.

Additional features of the new Product Guide include "Terminal Diagrams for Picture Tubes" and important facts about each of the three product families making up RCA's picture tube line.

• **"Top-of-the-Line" Solid-State Replacement Guide (SPG-202D).** You can "keep on top" of the solid-state replacements situation with RCA "Top-of-the-Line" SK-Series devices. In this handful of types – 17 transistors, 2 rectifiers, and 2 integrated circuits – are the equivalent of almost 9,000 solid-state replacements in entertainment-type equipment, including line- and battery-operated radios, phonographs, tape recorders, TV receivers, AF amplifiers, and automobile radios.

In the new RCA Solid-State Replacement Guide, the RCA SK-Series transistors and rectifiers – and the approximately 9,000 types they replace – are conveniently cross-referenced for quick reference. The 32-page Guide also includes "Dimensional Outlines & Terminal Diagrams" and an 8-page section

covering applications, operating considerations, and typical performance data for the RCA devices. Listed in the Replacement section are industry standard EIA types, foreign types, and those identified only by device manu-

facturers' or equipment manufacturers' parts numbers.

Make it a point to pick up a copy of this handy booklet on your next visit to your RCA Semiconductor Distributor.

Despite the increasing use of transistors and integrated circuits in home-entertainment products, the future for both the service technician and receiving-tube replacement market continues strong. Some reasons for this encouraging picture are contained in the following passages of a talk by Lysle O. Shanafelt, Manager, Sales Coordination, Distributor Sales, RCA Electronic Components and Devices. Mr. Shanafelt spoke before the 1967 Radio-TV-Electronics Service Industry (NATESA) Convention in Chicago.

"Technologically Speaking..."



L. O. Shanafelt

... The service end of the consumer electronics industry will run around \$1.65 billion this year – reflecting an increase of 10 per cent over 1966. It is estimated that another 10-per cent increase next year will boost the 1968 volume to about \$1.8 billion.

... I'm sure you remember back a few years ago. The transistor was invented and a coffin was being built to bury the receiving-tube business. Well, it isn't dead yet, and with manufacturers pumping out television sets at the present rate – especially color sets using an average of 23 tubes each – there's plenty of life in the old bulb yet.

... Color television is now your big and growing market. The 45 million color sets predicted to be in use by 1970 – when added to the black-and-white sets in use – means a renewal market of over 100 million tubes per year well into the next decade. And remember that the average price of the receiving tube used in color is higher than that used in black-and-white. And – lest we forget – there is that big-ticket color picture tube replacement market.

... I don't want you to think that RCA doesn't recognize transistors – in fact, we make them. The transistor is never expected to develop a replacement market equal to tubes, but it is – and has been – responsible for the development and sales of a vast array of home-entertainment devices in the last few years. I recently saw a figure indicating that over 500 million transistors are presently in use in this country in home-entertainment instruments alone. And get this – the 500 million does not include any imported transistors. With this many sockets, the failure rate doesn't have to be very high to develop into a respectable renewal market.

... Speaking of opportunity – how many motors do you have in your home? You'll be amazed if you count them when you get home. And in each case, there's a speed or time function involved that makes that motor or appliance subject to electronic control."

ABC's of Transistor Testing

by Rhys Samuel

Electronic Instruments Operations
RCA Electronic Components and Devices

If your daily troubleshooting involves transistorized circuits, you may have wondered whether a transistor tester is a worthwhile investment.

A shorted or open transistor can be detected by VOM or VTVM resistance measurements. But the two most important transistor characteristics — beta and leakage — can be determined only through use of a transistor tester.

Both the troubleshooting procedure and transistor replacement can require measurement of beta and leakage. Because there is no efficient substitute way of determining these characteristics, a transistor tester is a worthwhile and necessary instrument for troubleshooting.

But the value of a transistor tester for such work depends on its design and how it is used. To accurately cover the wide range of transistor types now in use, the tester must incorporate several specific design features. In addition, the user must know a few facts about in-circuit and out-of-circuit transistor testing, as follows.

"Beta" Measurements

"Beta," or common-emitter forward current-transfer ratio (h_{fe}), expresses the gain characteristic, and it can be determined either through an AC or DC voltage. Here are some points about beta measurements to keep in mind when troubleshooting transistorized circuits:

1. *The collector current level has a direct effect upon beta* — whether the transistor is tested in or out of circuit. Shown in Figure 1 is a beta curve for the RCA-2N2475 transistor. This curve illustrates how beta for this transistor type can vary from approximately 53 to 28 as the collector current is adjusted from 1 to 100 milliamperes. The published data for most transistors denotes the "DC beta" for specific conditions of DC voltage and temperature. The practical significance this characteristic has to troubleshooting is this: a single level of collector current will not provide an adequate beta measurement for all types of transistors. Therefore, a transistor tester which provides for setting the collector current over a wide range of values will be better able to test diverse transistor types, such as small-signal RF and high-power audio transistors.

2. *AC beta is a function of frequency.* Shown in Figure 2 are the frequency limits for the AC beta of a transistor. The gain-bandwidth product is the frequency at which the beta is equal to unity, and indicates the approximate useful frequency range of the device. The frequency-cutoff point is the frequency at which the alpha (common-base forward current-transfer ratio) drops to 0.707 times its 1-kHz value. These cutoff points vary widely with transistor types. In many consumer applications, transistors are now operating at frequencies up to 1,000 MHz. Significant tests of the frequency characteristics require elaborate RF measuring facilities. Consequently, it is not practical to include them in service-type transistor testers. It is apparent that an AC-beta tester which uses only a 60- or 1,000-Hz test signal cannot provide a significant indication of transistor performance at RF, VHF, or UHF frequencies.

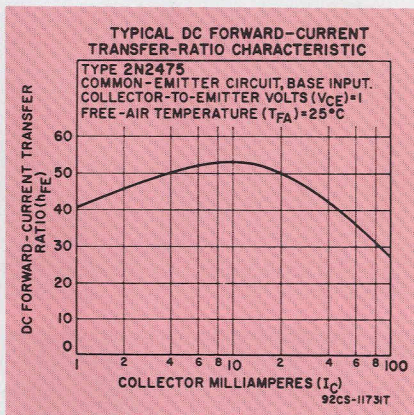

Figure 1: DC beta curve for the RCA-2N2475 silicon n-p-n epitaxial planar transistor. Note how beta varies with level of collector current.

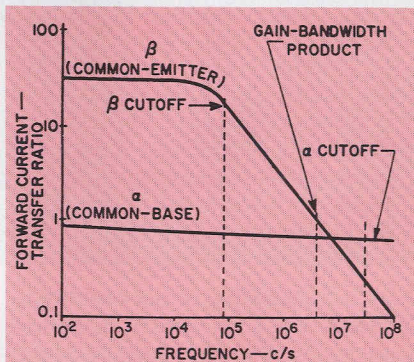
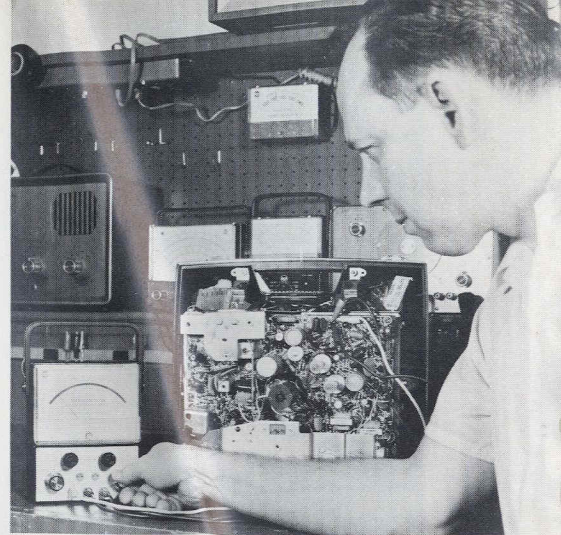

Figure 2: Forward current-transfer ratio as a function of frequency.



3. *The transistor beta specified by manufacturers for most transistors is a DC beta.* AC beta figures are usually reserved for RF and higher-frequency types. In many of the latter cases, the DC beta is likewise specified.

4. *If a transistor has insufficient current gain, its condition will be disclosed by either a DC- or an AC-beta test.* Unlike electron tubes, transistors do not exhibit gain slumps due to materials depletion. In addition, beta does not normally change as the transistor ages. A defective transistor can be readily detected because it will have little or no beta; will give a shorted or open indication; or will have excessive leakage — a topic discussed further on in this article.

5. *In-circuit beta readings may be lower than out-of-circuit readings for the same transistor.* Variations will depend on the circuit resistance. In most cases, these differences will not be substantial. In some in-circuit tests, however, meaningful beta readings cannot be obtained because of low circuit resistances. The horizontal-deflection-output stage of a TV receiver is a good example. In such situations, it will be necessary to test the transistor out of circuit.

6. *In most applications, a reference beta figure for an in-circuit or out-of-circuit transistor may not be available for several reasons:*

- "Good" transistors of any one type may display a very wide spread in betas and still be acceptable for use in a specific circuit.
- In-circuit beta may be affected by circuit configuration and operating parameters.
- The beta figure published by manufacturers is usually the average, or design center, of a very large number of tested devices.
- Equipment service notes do not specify reference beta figures for in-circuit measurements for the reasons given above. In spite of these factors,

interpretation of beta measurements and their significance is not a guessing game. A defective transistor will have little or no beta; will cause the pointer to slam against the meter stop of the tester; or make it impossible to calibrate the tester prior to beta measurements. It would appear, then, that discrete beta values have little significance in service work. This is not true. In most applications, a minimum gain characteristic is needed, and it is often necessary to "pair up" transistors for complementary-symmetry circuits in various types of equipment, including the audio amplifiers of radio and TV receivers.

7. A transistor with low beta (or excess leakage) may be satisfactory for use in noncritical circuits. It is necessary, therefore, to consider test results in terms of the application. For example, a transistor having low beta may be satisfactory in some audio-

2. A transistor having a given amount of leakage may be useable in some applications and not in others.

3. Silicon transistors generally have much lower leakage than have germanium types.

4. I_{CBO} of most small-signal silicon transistors will be less than one microampere.

5. Some acceptable silicon power transistors may have an I_{CBO} as high as 50 microamperes.

6. The I_{CBO} of most germanium transistors will be less than 100 microamperes.

7. Germanium power transistors often have an acceptable I_{CBO} of several milliamperes.

8. Leakage measurements can be made only with the transistor out of circuit.

Choosing a Transistor Tester

The beta- and leakage-measurement considerations discussed above indicate that a transistor tester must include several specific features to be a reliable measurement device. Among the more important considerations are these:

- The capability to measure beta at the collector-current level best suited to the transistor type or its application. This capability should extend to the handling of devices ranging from small-

signal RF and IF transistors — with nominal collector currents of a few milliamperes — to high-power types having ratings up to one ampere.

- The facility to provide beta readings with an accuracy of $\pm 5\%$ both in and out of circuit. (Remember, however, that beta is directly affected by the collector current.)

- An adjustment which permits leakage current to be "bucked out" before the beta measurement is made; otherwise, the beta reading may be upset by the leakage current. In the case of high-leakage germanium power transistors, the resultant beta reading may be significantly inaccurate. This rule applies to both in-circuit and out-of-circuit tests.

- The means for calibrating the beta test for each transistor tested.

- A facility for reading leakage current directly in values as low as one microampere.

* * *

These are the primary requirements of a good transistor tester. Other features are desirable, of course, to make the tester completely reliable and easy to use.

All of the necessary and desirable features have been included in the new RCA WT-501A Transistor Tester — a measurement instrument that combines service speed and simplicity with laboratory-measurement qualities.



Figure 3: In-circuit beta readings may be lower than out-of-circuit readings for the same transistor.

amplifier circuits but not be useable in a small-signal RF circuit. A transistor having high leakage may be acceptable in an audio stage but be useless in a high-frequency circuit.

Leakage Measurements

Collector-to-base leakage (I_{CBO}), measured with the emitter open, is the critical leakage of both germanium and silicon transistors. But these two basic types can display wide differences in their leakage values and in levels of acceptability.

A transistor tester should measure leakage directly in milliamperes or microamperes. Here are some factors to keep in mind when interpreting measurement results and levels of I_{CBO} acceptability:

1. I_{CBO} limits for any particular transistor type are usually specified in general data or in equipment service notes.

Dave Gives You Full Support On Nationwide TV!

Dave Garroway is your spokesman — and he's delivering an important message to television viewers from coast to coast.

It's the message of RCA HI-LITE color picture tubes for the replacement market — *the story of RCA quality* — vividly told through a full-minute commercial, naturally in color.

This message is now being presented to millions of viewers of the Walt Disney "Wonderful World of Color" over the NBC-TV network. It's also being relayed to millions of

sports viewers tuned in to the AFL Football colorcasts. Here is A-1 coverage at its best — during the exciting Fall TV season when viewing audiences are gauged at an all-time high.

RCA'S unmatched experience in color and the Dave Garroway color commercial make up a powerful sales combination — a real "action team" that should sell more customers on RCA quality . . . spell more business for you in RCA HI-LITE, the industry's finest replacement color picture tube.

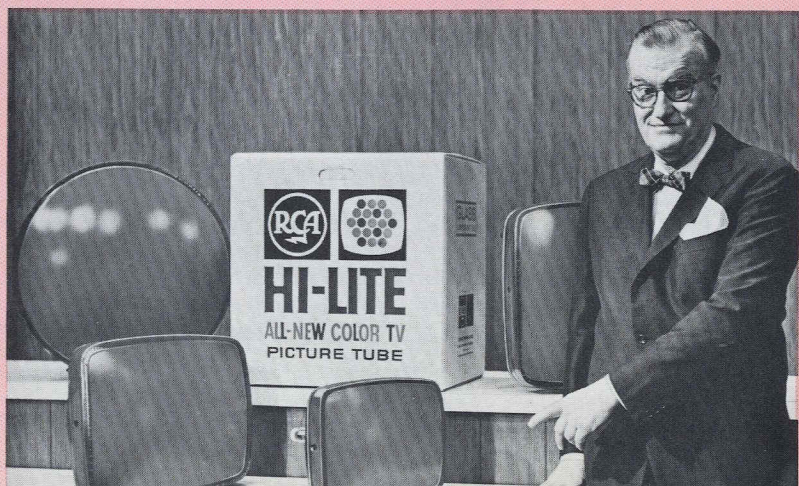

Across the Bench

By 'Doc'



Every few months, I try to clear out the stack of magazines I've been saving in the shop. The result is always the same. I end up reading so much I never get to the bottom of the pile.

Take today, for instance. I got sidetracked on articles and advertisements on 'scopes. Sometimes I think the guys who write that stuff never had to fix a TV set.

I've owned half a dozen 'scopes — good and bad — since I started in this business, and I've gotten my mileage out of each one. If you haven't gone the route like I have, let me tell you a few things about these instruments you won't find in magazines.

First, I'd say that no 'scope is completely worthless — even if it's 30 years old. I'm thinking of an old 3-inch model I just gave to the kid who cleans my windows. That 'scope had only 200-kHz bandpass and couldn't even show a decent sync pulse. But it was fine for sweep alignment.

You don't need a wide-band 'scope for sweep work — even if you're aligning tuners or 40-MHz IF strips. The 60-Hz sweep signal you take out of the TV set is already demodulated. All you need to display it is some gain and response at 60 cycles. That covers a lot of antiques!

Old 'scopes are almost impossible to modernize. You can add voltage calibration, but you can't increase the gain or bandpass without a complete redesign from front end to power supply.

But don't be too quick to throw out your narrow-band 'scope. If it has decent gain and a bandpass of a megahertz or so, you can get a lot of use from it in black-and-white and color work. True, you can't use it for checking color signals, but you can still use it in most other parts of a TV set.

I'm not saying you don't need a good wide-band 'scope. If you service color sets, you can't get to first base without one.

You can buy a "wide-band color 'scope" for any price from \$130 to \$300. On paper, they're all marvels. If you use them, however, you'll soon find some sharp differences in performance. Here are some of the less-ballyhooed features I check on a new 'scope:

For example, one of the most important check points is the input attenuator or "V" range switch. I count the number of positions it has. This switch acts the same as a range switch on a VTVM.

But did you ever see a 3-position range switch on a VTVM? Of course not! But you'll find some 'scopes with only three input ranges to take you from a few millivolts up to 500 or 600 volts. My 'scope has six ranges, which give me a 3-to-1 attenuation ratio — just like a good VTVM.

I also check trace stability. If there's anything that gets me talking to myself, it's a 'scope trace that moves around the screen. Drift, trace jumping, and off-screen deflection are common to some 'scopes — especially those having direct-coupled amplifiers.

DC amplifiers can be indispensable in some applications. But you don't need them in TV work. I settle for a solid, AC-coupled 'scope for stability. It will do anything I want it to for TV troubleshooting.

But an AC 'scope can suffer from "line-bounce." If you've got a power line with poor load regulation, it will cause the 'scope trace to bounce up and down each time a load is switched.

There are two ways to get rid of bounce in a 'scope. One is to regulate the internal 'scope voltages. That's expensive. The other is to decrease the value of the interstage coupling capacitors in the 'scope. But that can give the 'scope poor low-frequency response.

I'd rather live with an occasional line bounce and know that my 'scope has good low-frequency response. It's really needed when you're checking hi-fi systems or squinting at a horizontal sync pulse.

Along with a stable trace, I want a clean trace. To get it, a 'scope must have good external and internal shielding. I look first at the probe and cable. They have to be shielded. I also make sure that the 'scope has some kind of shielded input connector — not a pair of open-air binding posts. When you're operating a 'scope at high gain, you don't want the input leads and connectors picking up unwanted hum, hash, and deflection pulses. All of it will show up on the trace.

The greatest weakness of some high-

gain 'scopes, I've found, is internal hum. It's easy to design a high-gain amplifier, but it takes talent to make it clean. Here's how to check a 'scope for hum:

Turn the input controls up full, and connect the probe and cable. Short the probe tip to ground. Then, switch the sweep-range control to the low range. If the 'scope is hum-free, the horizontal line will be flat and of even intensity. If it has uneven intensity, or if it is not a straight line, the 'scope has hum.

Any 'scope worth its salt shouldn't have any internal hum — even at maximum gain. My 5-inch 'scope can pass this test without straining — and it has 18-mV-per-inch sensitivity.

Sync-circuit design, too, has a lot to do with waveform stability. But there's no way you can judge sync stability other than by running a 'scope through its paces. Two different 'scopes can have identical front-panel sync facilities but vary widely in performance.

For TV work, solid sync action is needed at the vertical and horizontal frequencies because these are what you use in 90 per cent of your 'scope work. My 'scope has preset sync positions for both these frequencies — a real convenience when you're jumping a probe around a chassis.

The best sync feature I've seen in any service 'scope, though, is a sync separator circuit just like that used in a TV receiver. This circuit takes the composite signal, such as you get from the receiver picture detector, and separates out the "V" and "H" sync pulses. Then, the 'scope uses these pulses for locking in the signal.

This system is great for locking in on pulses or on the composite waveform — video and all. It really makes for stable sync — a hard-to-get feature on some 'scopes.

The points I mentioned are just a few of the things I look for in a 'scope. As I said earlier, you don't find them all spelled out in the magazines. And they're not the things you usually hear about — like sensitivity, bandpass, and price. But they are some of the qualities I insist on when some guy tries to sell me a razzle-dazzle 'scope that will do everything at half the price.

If you're looking at a new 'scope and don't have time to check all the features mentioned, try this fast, two-second test for quality: just pick up the 'scope.

The one I use weighs 30 pounds. And it has all the good qualities I've been talking about — plus more.

It's the RCA-WO-91B.

PLAIN TALK

AND

Technical Tips

RCA KCS-153 Solid-State TV Chassis

Transistorized AGC Circuits

Since radio and television signals will vary greatly in signal strength from station to station and from one locality to another, it is important that some provisions be made in the receiver circuits to "level off" these variations.

Automatic Gain Control (AGC) circuits are employed to accomplish this purpose. In tube-type circuitry, the "remote cut-off" type tubes permit the use of a bias voltage (derived from the incoming signal) to vary the over-all gain of the receiver.

In solid-state circuitry, this becomes more difficult since the transistor is basically a "sharp cut-off" device. Many radio receivers use the *overload diode* to accomplish a measure of "AGC."

In this circuit, an increased incoming signal causes an increase in voltage drop on R12 (Figure 1), which causes the overload diode to conduct. This produces a "shunting" effect on the primary of T3 which *reduces* the gain of the system.

The transistorized television chassis of the RCA KCS-153 employs a special AGC circuit which controls the gain of the RF amplifier and the 1st IF amplifier to achieve AGC action.

The system consists of a closed loop made up of the AGC gate, the RF amplifier, IF amplifier, 1st video amplifier, and back to the AGC gate. The circuit maintains a constant voltage at the emitter of the first video amplifier over a wide range of signal inputs.

It is a "gated" or keyed AGC system in which an AGC voltage is developed at horizontal sync time and sustains for the duration of the horizontal scan time. Sync tips only are utilized to produce the control voltage; the system is noise immune and not affected by scene variations.

input signal to the "AGC gate." The AGC gate is rendered operative at horizontal sync time by a 30-volt negative pulse from the HV transformer which is applied to the collector of the AGC gate. At that time, the AGC gate amplifies the sync signal which is simultaneously occurring at the base. A positive AGC voltage is then developed, and is retained during scan time by the long time-constant of the AGC bus. In order to prevent the collector-to-base junction of the AGC transistor from becoming forward biased by this developed AGC voltage, a diode is inserted between the AGC gate collector and the AGC bus. The positive AGC voltage so formed is then applied as forward bias on the RF amplifier transistor. This reduces the gain of the RF stage.

The RF amplifier then serves a "dual" role. In addition to its function as an RF amplifier, it amplifies and inverts the AGC voltage variation, delivering

(Continued on next page)

Operation of the AGC circuits is as follows: As signal increases at the antenna, the output of the first video amplifier tends to increase. The increased video level is applied as an

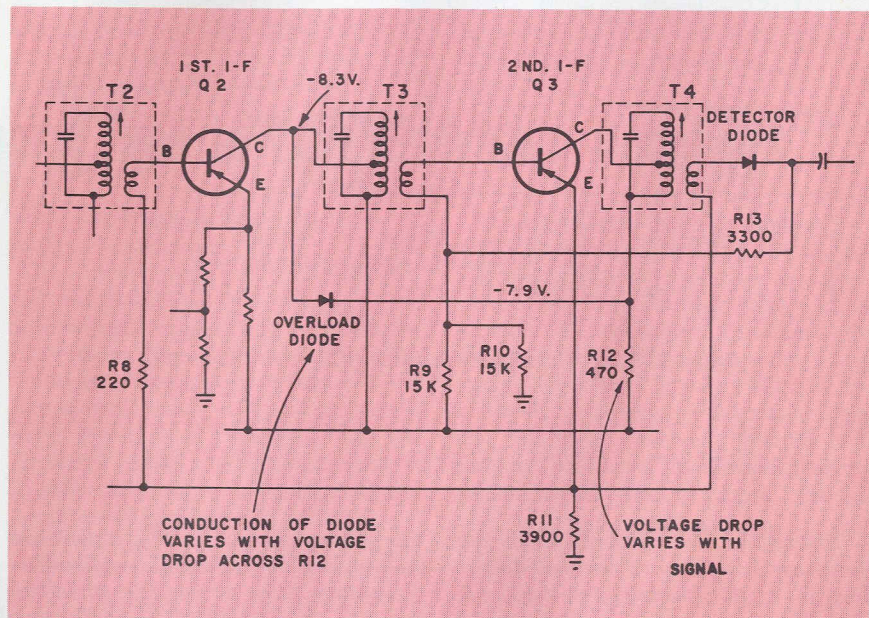

Figure 1: The overload diode.

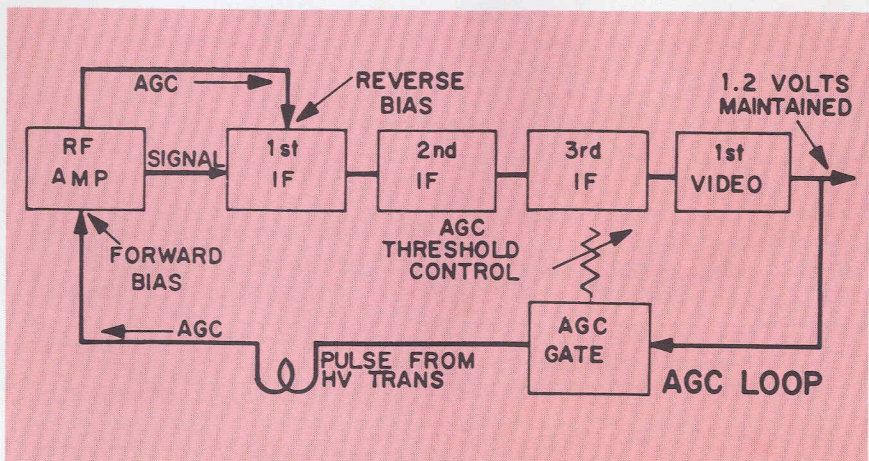

Figure 2: The KCS-153 AGC System.

Plain Talk and Technical Tips

(Continued from preceding page)

it to the base of the first IF amplifier as reverse bias. This reduces the gain of the first IF amplifier.

It should be noted that either reverse bias or forward bias will cause a reduction of gain in a transistor amplifier.

In one case, the cutoff characteristic of the transistor is utilized, and in the other the saturation characteristic is utilized.

In this manner, both the RF amplifier and the first IF amplifier act to reduce the gain of the system.

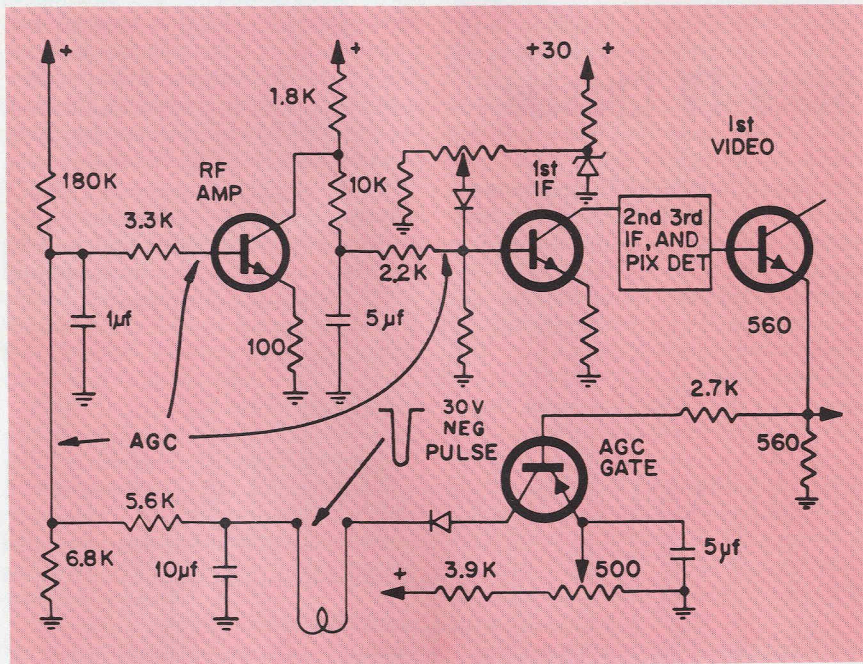

Figure 3: Simplified schematic of the KCS-153 AGC circuit.

Transistorized Vertical Deflection Circuits in the KCS-153

Transistors now perform all of the necessary functions of vertical deflection in a transistorized television set since the frequency of operation and

the power required in this circuit are well within the capabilities of modern transistors. Most of the circuit refinements in a practical transistor television

vertical circuit are concerned with obtaining a high degree of stability and good linearity.

The vertical circuits of the KCS-153 chassis consist of a vertical oscillator (synchronized with incoming vertical sync pulses), a "pre-driver" stage, a "driver" stage, and a vertical-output stage.

The oscillator and output transistors work as a feedback system and are grounded emitter circuits. The pre-driver stages are DC amplifiers which are "emitter followers" or common collector circuits. A very linear rise in current through the vertical-deflection yoke windings is accomplished by this vertical-deflection system.

The vertical oscillator can be considered as a "switch" which is CLOSED at retrace time and OPEN during vertical scan time.

Oscillation is sustained by positive feedback from the yoke to the base circuit of the vertical oscillator.

OFF time, or that time during which the oscillator transistor is open, is controlled by the large time constant in the base circuit of the oscillator. This corresponds to sweep time. ON time of the oscillator occurs when the voltage on the base of the vertical oscillator becomes lower than the emitter. This happens quickly, and lasts for a very short duration. This is vertical retrace time.

The switching action is utilized at the collector of the vertical oscillator to quickly connect the sweep capacitor to +30 V at retrace time and permit a linear decrease in voltage on this capacitor during SCAN time or while the oscillator transistor is OFF.

The pre-driver and driver stages perform the function of isolating the vertical-output stage from the sweep-capacitor charging circuit.

The sweep capacitor during retrace time is discharged rapidly due to the 130-volt flyback pulse. During scan time, the capacitor starts a gradual exponential buildup, however, this buildup is "linearized" by the feedback from the output transistor, which tends to keep the charging current constant. This produces a very linear voltage rise.

The output transistor then drives an impedance-matching auto-transformer to feed the deflection yoke through a DC blocking capacitor.

Other circuit features of the KCS-153 vertical circuit include a VDR across the output transistor which protects it from the large flyback pulse. A VDR is also used to stabilize the bias voltage of the oscillator transistor.

The over-all performance of the vertical circuits of the KCS-153 chassis

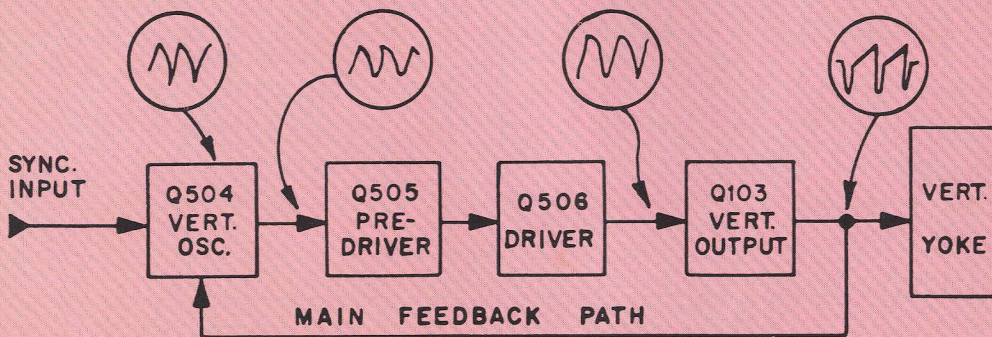

Figure 4: Block diagram of the KCS-153 Vertical.

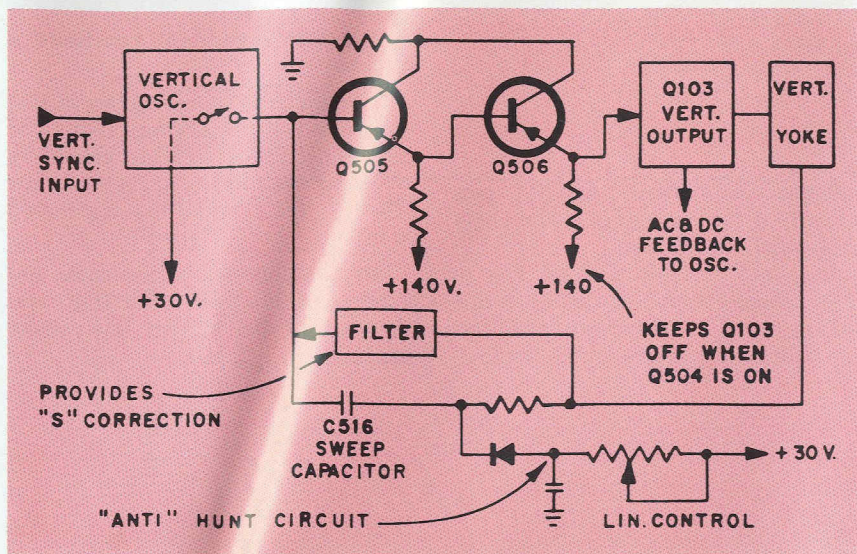

Figure 5: Simplified schematic of the driver stages.

delivers a linear, stable vertical scan. Circuit refinements insure good noise immunity, freedom from line-voltage variations, independence from varying transistor characteristics, and full control of the vertical-sweep waveform

with the usual height, linearity, and hold controls.

Service can be performed on transistor vertical-deflection circuits by using signal injection. The circuit can be treated as a 60-cycle amplifier, and

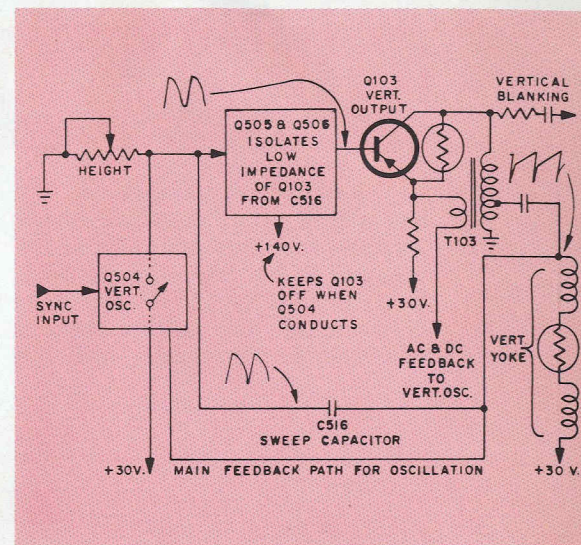

Figure 6: Simplified schematic of the vertical output.

when 6.3-volts AC is fed through a blocking capacitor ($5 \mu\text{f}$ to $10 \mu\text{f}$) to various points, an isolation to a particular stage can be made. Voltage and resistance readings are then used to further isolate a component.

Transformer Primary Taps in RCA Television Receivers

RCA Victor transformer-powered black-and-white and color television receivers are now equipped with a 120-volt and a 128-volt primary winding on the power transformer. The 120-volt tap is used for normal line voltages (instruments are shipped with the 120-volt tap in use), and the 128-volt tap is used when higher than normal line voltages are encountered. A simple disconnection of one lead and a reconnection of the other lead (tapping the un-

used lead) is all that is required to make a changeover.

For many years, 110 volts was considered as nominal line voltage. Later, line voltages from 115 to 117 volts became more prevalent. Present-day line voltages average around the 120-volt figure, with many areas encountering even higher line voltages. With the choice of either a 120-volt primary or a 128-volt primary, most line-voltage conditions can be accommodated.

The service technician can use several checks to determine which line tap should be in use. One is actual measurement of the line voltage using a good AC voltmeter. Another is to examine the width of the picture and noting whether it appears extra wide. It should be remembered that, in modern television receivers, picture size may be "regulated" by special circuitry which would tend to "mask" the re-

(Continued on next page)

Free Tube Replacement Program Now in Effect:

RCA-1829P22
19-Inch, 90-Degree
Color Test Tube
Replaced by
RCA-1830P22
Featuring Laminated
Safety Window

The RCA-1829P22 (19-inch, 90-degree) color test tube has been replaced by the RCA-1830P22 (19-inch, 90-degree) color test tube featuring an integral laminated safety window. Special laminating resin and bonding techniques are employed in the new RCA test tube to provide added protection against the potential hazard of picture tube implosion.

It has been reported that the RCA-1829P22 test tube was being used by some technicians in TV test jigs that do not employ separate implosion safety windows. Service technicians are reminded that this

tube type should be employed only when adequate external protection is provided.

If you're presently using an RCA-1829P22, and your TV test jig doesn't include—or cannot be modified to include—a protective window, you'll be interested to know that you may obtain the RCA-1830P22 in exchange for your operative RCA-1829P22 at no added cost. For complete information on this special test tube exchange, contact the RCA tube distributor from whom you purchased your RCA-1829P22.

Plain Talk and Technical Tips

(Continued from preceding page)

relationship of picture size to line voltage. Another check is measurement of B+ voltages. If B+ is consistently high, then the use of the 128-volt tap would be suggested. Still another check is tube failures. Consistently high line

voltages can shorten tube life, particularly if the line tap is in the lower (120-volt) connection.

It should be kept in mind that in cases where extreme *variations* in line voltage occur, or where *extremely low* line voltages are encountered, the line-

voltage tap would not constitute a remedy.

A simple rule to remember is that when line voltages average above 125 volts, the 128-volt line tap should be used, and when line voltages are below 125 volts, the 120-volt line tap should be used.

Improved over-all performance and longer tube life will result from employment of the correct line-voltage tap.

Checking Horizontal-Output Circuitry In the RCA CTC-24 Color Chassis

The basic five-step procedure outlined below is a recommended guide for testing horizontal-output circuits in modern color chassis. The method is fully adaptable to other color chassis by reference to the appropriate service data.

Nominal voltage and current readings shown in the Figure-2 schematic (in this instance, a CTC-24 chassis) reflect conditions with input line voltage adjusted to 120 volts.

Check Drive Waveform

1. Check Drive Waveform. Proper drive waveform to the grid of the output tube is necessary for efficient and safe operation of the horizontal output tube. Normal pulse amplitude is 220 to 235 volts P-P. Correct waveform indicates normal operation of the horizontal oscillator stage. *Minimum* P-P drive acceptable here is approximately

220 volts; a lower reading indicates trouble in the oscillator tube or associated components. For example, the possible causes might include:

a. Weak horizontal oscillator tube (6FQ7) does not discharge timing networks properly, decreasing the amplitude of the drive signal.

b. Defective component in timing network, most likely a shorted C260, or off-value C262. Changed values for R276, R278, or R279 can also affect the drive.

Check Grid Bias Voltage

2. Check grid bias voltage. Normal DC bias on grid is approximately -56 volts, determined by the grid-drive signal and hold-down bias network R759-R277 — the latter circuit functions to keep high voltage from rising above 33 kV if the regulator tube fails.

Low grid bias (less negative) can be

caused by the following conditions:

- Improper drive signal
- Low value of R277
- Faulty 6JE6A

High grid bias (more negative) can be caused by:

- Faulty 6JE6A horizontal output tube
- Higher-than-normal negative voltage at blanker grid (Blanker voltage can be checked by disconnecting R759; disconnecting R277 from 140-volt B+, and connecting it to chassis ground. Normal grid bias of -56 volts should be developed under these conditions.)

Check Cathode Current

3. Check cathode current. Nominal cathode current is 225 mA (for 25-inch-type chassis) with properly adjusted horizontal oscillator, efficiency

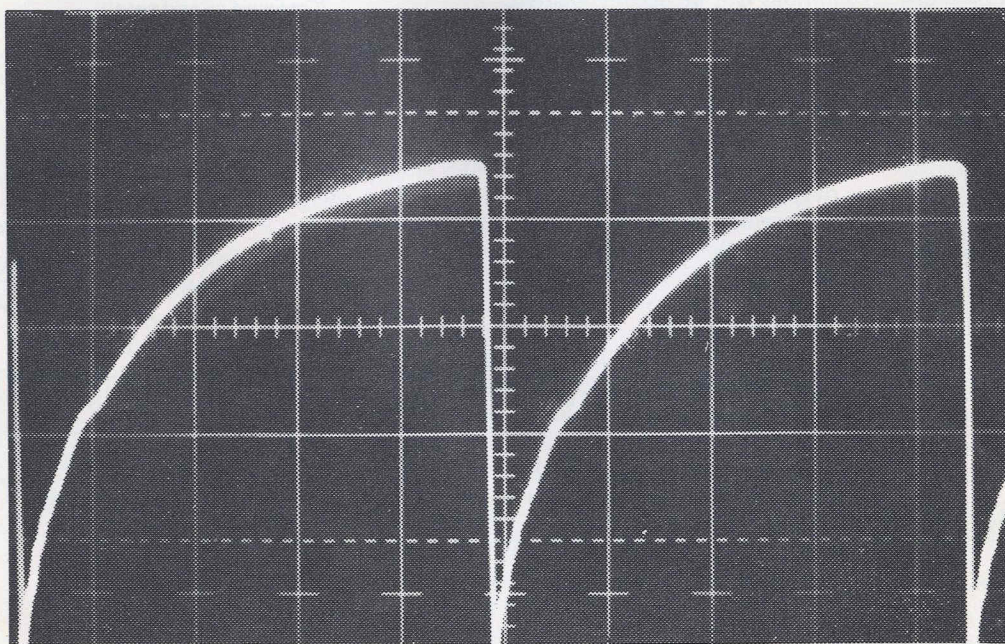

Figure 1: Drive Waveform. Proper drive waveform to the grid of the output tube is necessary for efficient and safe operation of the horizontal output tube. Normal pulse amplitude is 220 to 235 volts P-P.

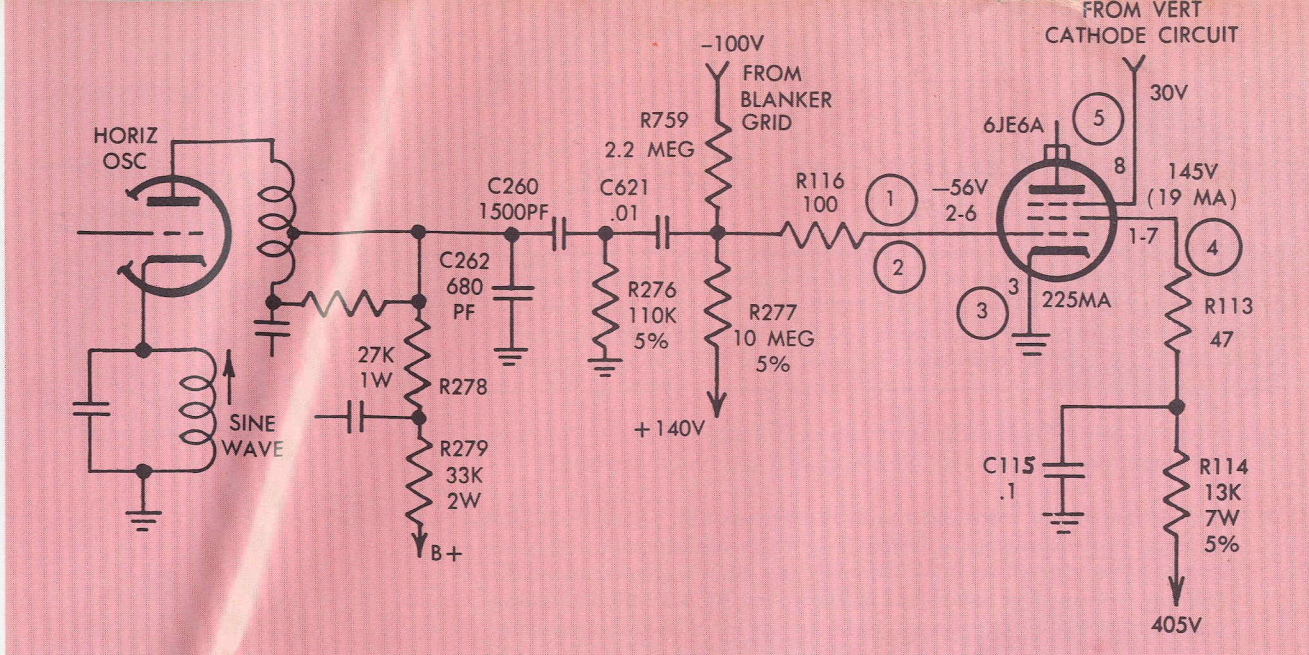

Figure 2: RCA CTC-24 Color Chassis horizontal output.

coil, and high-voltage controls. Maximum safe current is 235 mA. Total current depends on input drive, output load, efficiency-coil adjustment, and screen-grid operation. If current is near maximum safe limits, perform a monitor check as follows:

- Operate the set for 5 minutes; perform HV adjustments; and check current.
- Recheck current "dip" and (re-set) after 30 minutes of operation.
- Permit set to cool. Perform Test Number 2. Excessive current can be caused by a bad horizontal output tube (6JE6A); low drive signal; screen-grid load; misadjusted or defective efficiency

coil; or overload from the flyback system.

Check Screen Voltage

4. Check screen voltage. The screen grid is an important check point of 6JE6A operation. Normal screen voltage in this circuit is 145 volts with 405 B+ source. Normal screen current under these conditions is 19 mA. Excessive screen current, leading to shorter-life 6JE6A, is normally caused by:

- Decrease in screen load resistor values
- High B+ voltage

- Improper load on horizontal output by flyback system
- Defective tube

Check Suppressor Grid

5. Check the suppressor grid. Voltage on the suppressor grid should be 20 to 40 volts, obtained from the voltage divider in the cathode circuit of the vertical output tube. Positive voltage improves the operating characteristics of the 6JE6A. A wrong voltage that could change tube operation would be evident by an upset in the vertical sweep on the screen of the picture tube. Suppressor-grid bias is derived from the cathode of the vertical output tube.

Acoustic Feedback or "Howl"

Acoustic feedback, or "howl," in an audio system normally results in some form of distortion being emitted from the loudspeaker. It may take any form ranging from a low-frequency hum (similar to a defective power supply filter) to a high-pitched shriek. It is normally caused by mechanical vibrations from the loudspeaker inducing similar vibrations in some component that reconverts the vibrations into electrical signals. These undesired signals perpetuate themselves until stopped by an electrical or mechanical barrier.

Acoustic feedback can occur in any type of sound-producing instrument. A sensitive part in an RF tuner can cause trouble in the sound of a television receiver or a loose assembly in a

record changer can generate acoustic feedback.

The possibility of acoustic feedback in a phonograph is always of great concern. Record-changer hold-down screws that are not loosened or not loosened sufficiently is one of the major causes. These screws should be loosened sufficiently so that they allow the changer to "float" on the mounting springs. The screws should be free in the holes.

Another possible cause of feedback in a record changer may be found in its electrical cables. In some cases they are drawn too tight and in other cases they are looped between the changer and the sub-board. In either of the

above cases, the free-floating shock barrier of the changer is destroyed by the wire tension and a mechanical path is set up that will transmit vibrations. The pickup and motor cables from the changer should drop freely through their respective holes.

In cases where a chassis or component is shock-mounted on grommets — such as a tuning gang — see that the grommets are not cut through. Such a condition may allow the chassis to touch the mounting stud and set up acoustic-feedback conditions.

These are just a few of the ways that acoustic feedback can be developed, and are by no means all the possible causes.

"Next Question, Please"

Here are answers to some of the questions radio/TV/hi-fi technicians frequently ask about RCA test instruments or the troubleshooting and servicing of equipment in general. You may find this information of particular interest or application to your own field of operations.

Q — I have a WV-97A VoltOhmyst® which I bought in 1951. Recently the power transformer burned out. Can I get a replacement?

A — Yes. Although this instrument is over 15 years old, you can still get an exact replacement part. Order it by RCA replacement-part stock number (see instruction book) through any RCA test-equipment distributor. You may be interested to know that RCA maintains a long-range replacement-parts inventory for nearly all of its test equipment.

Q — When I short the test leads on the "R x 1" range of my WV-38A VOM, the meter pointer won't go to zero — even with the ohms adjust control turned all the way over. What is the matter?

A — Make sure the test-lead points are clean. If so, change the 1.5-volt battery. A weak or exhausted ohms battery is indicated by the condition you describe. It should be added that this symptom is also common to VTVM's which have weak ohms batteries.

Q — In testing hi-fi equipment, it is often necessary to measure AC input signals down to .001 volt or so. I have two VTVM's, but neither can measure that low. Do you make an amplifier I can use for my VTVM?

A — No. But you can use a simple resistance divider to get the desired voltage, as follows:

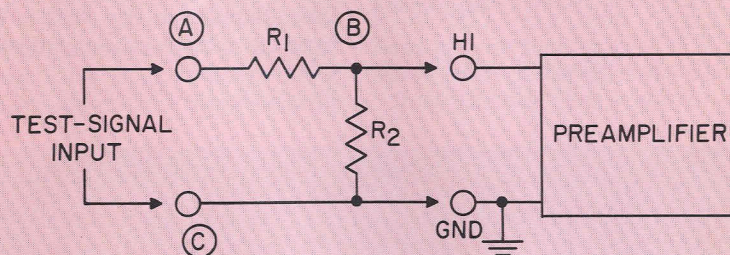

R1 should have a high ratio to R2, such as 100-to-1. To get 0.005-volt input to the preamp, then, it is necessary to apply 0.5 volt between terminals "A" and "C". Most VTVM's can measure 0.5-volt AC without difficulty.

There is also an easier way: use an AC VTVM, such as the RCA WV-76A. With this high-impedance instrument, you can measure directly down to 200 microvolts from 20 Hz to 1 MHz. The WV-76A can also be used as a flat-response preamplifier having 38 dB of gain.

Q — As most of the new TV sets have built-in degaussing coils, do I need a separate degaussing coil for servicing sets?

A — Yes. The built-in coil will not degauss cabinets and other metal parts external to the picture tube. And, you still have to degauss older sets which don't have built-in degaussing.

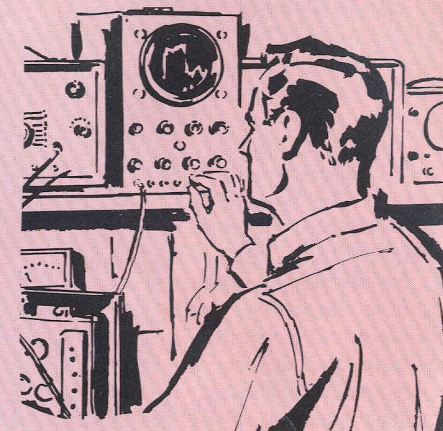
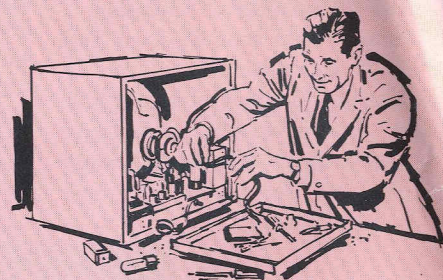
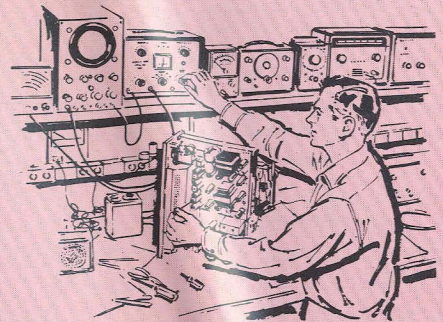

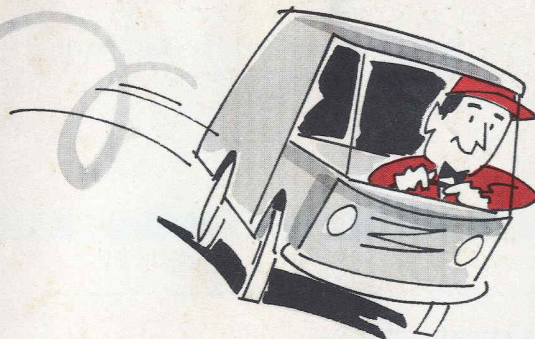

WEAK COLOR?

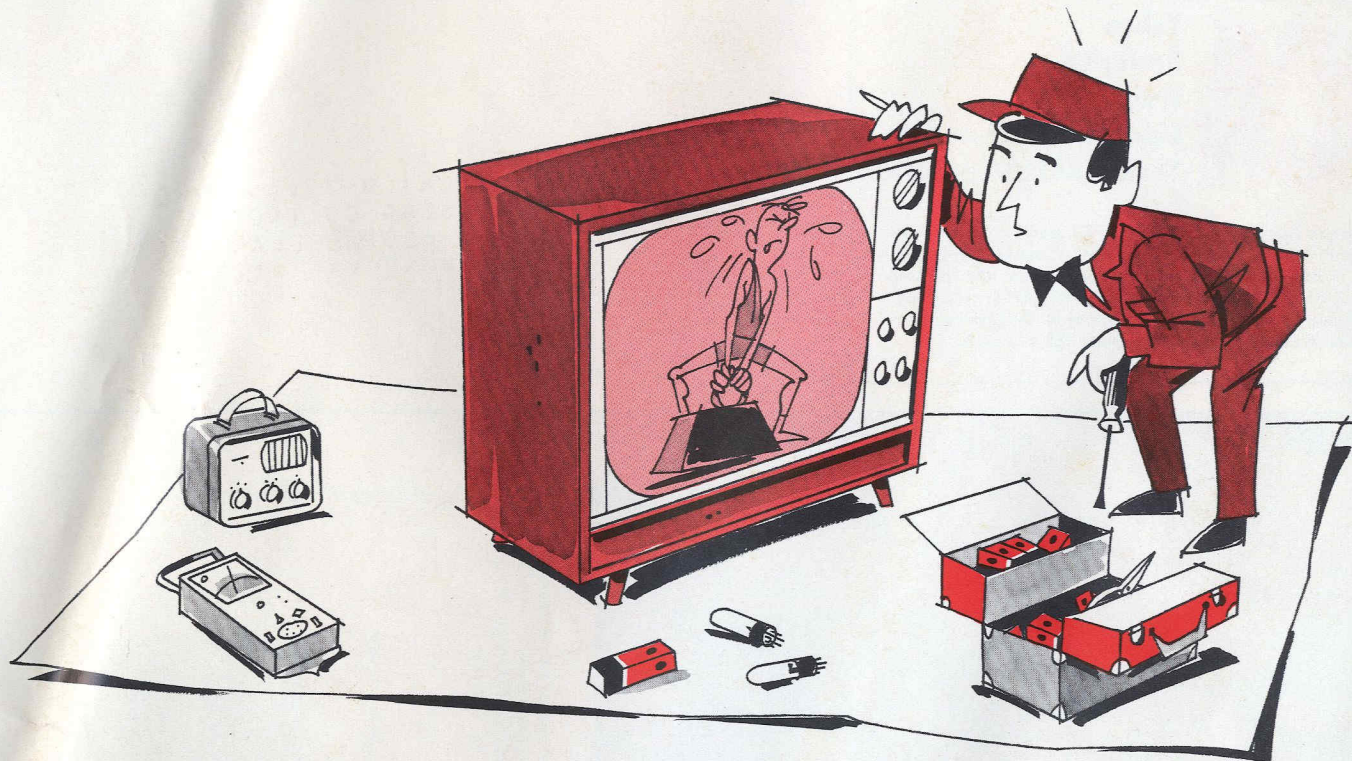

Follow these steps to isolate the trouble area...

If colors lack full saturation, make sure that fine-tuning, brightness and color controls are set correctly. Then determine the receiver section in which signal is attenuated as follows:

1. Apply an rf color-bar signal at the antenna terminals.
2. Connect a scope at the video detector. Check amplitude of the color-bar pulses and sync pulses. They should be approximately the same. If color-bar pulses are attenuated, check for trouble, including poor bandpass, between the antenna terminals and the video detector.
3. If amplitudes are correct, look for trouble in the chroma section, as follows:
 - a. Check bar-pulse amplitude at input and output of bandpass amplifier.
 - b. Check bar signal at input and output of demodulators and color amplifiers. Note: Trouble in only one of these stages will produce a *shift* in colors, which will show up in the color-bar pattern. Loss of color saturation in the demodulators or color amplifiers, therefore, indicates trouble in a circuit common to the demodulators or color amplifiers.
4. Once the defective stage or section has been found, use voltage or resistance measurements to pinpoint the circuit defect.

This is another in RCA's continuing series of color TV service hints, to help make your job easier. Your RCA tube distributor can also make your job easier, because he's your best source for quality RCA receiving tubes for color TV, as well as for black-and-white TV, radio and hi-fi. You enjoy more customer confidence and satisfaction when you replace with RCA receiving tubes,

RCA ELECTRONIC COMPONENTS AND DEVICES, HARRISON, N. J.



The Most Trusted Name in Electronics



The Most Trusted Name in Electronics
RADIO CORPORATION OF AMERICA

Compliments of Your
Local RCA Distributor

Headquarters for:

RCA
Tubes
Batteries
Transistors
Electronic Instruments
Technical Publications

Information furnished by the Radio Corporation of America is believed to be accurate and reliable. However, no responsibility is assumed by RCA for its use; nor for any infringements of patents or other rights of third parties which may result from its use. No license is granted by implication or otherwise under any patent or patent rights of RCA.

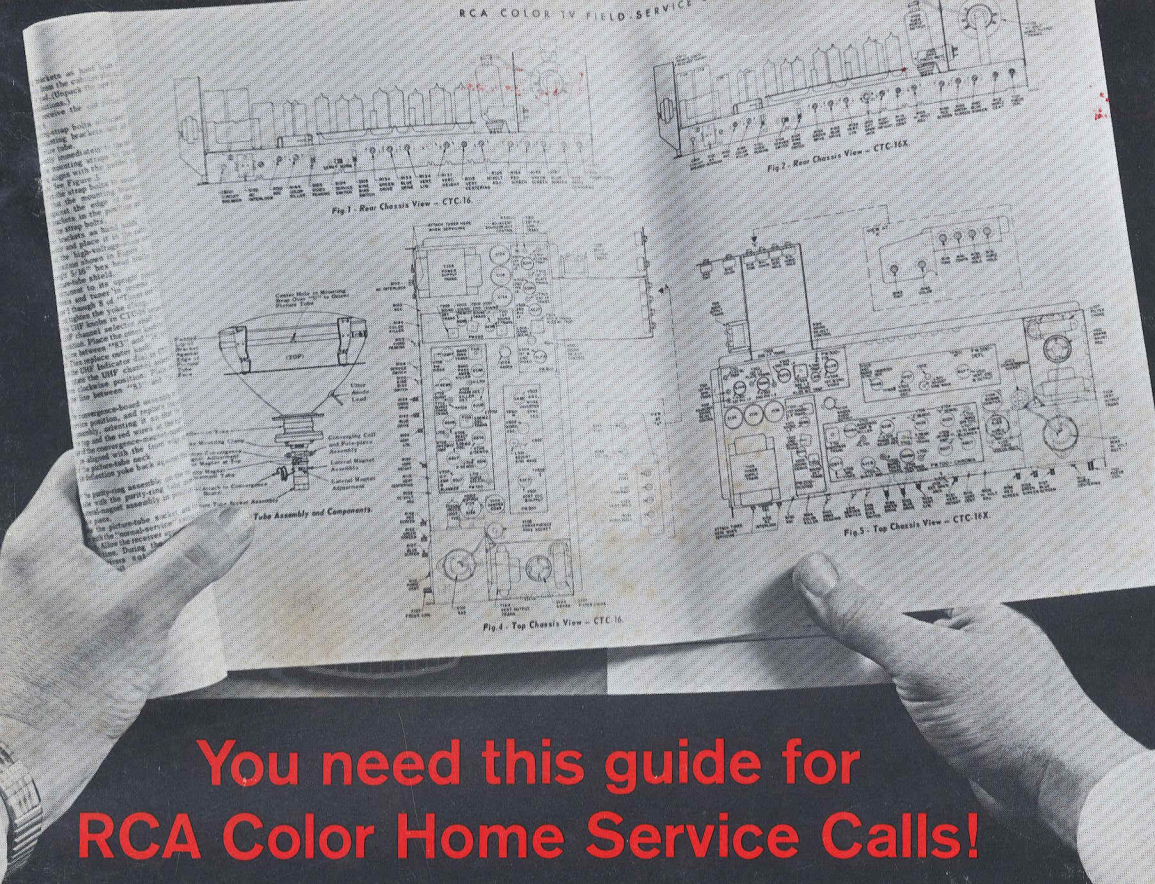

You need this guide for RCA Color Home Service Calls!

RCA'S NEW FIELD SERVICE GUIDE, ERT-200 helps you make all adjustments on all RCA color sets from 1955 to 1966 that can be performed in the home... including step-by-step procedure for replacing a color picture tube.

Three part index lets you look up the set you are working on by model number, name or chassis number. You'll find the ERT-200 Field Service Guide indispensable. There's nothing like it on house calls for RCA color sets.

WHAT THIS GUIDE CONTAINS:

- Schematics on all RCA color sets from 1955 to 1966
- Field service adjustments (AGC, linearity, centering, etc.)
- Convergence, purity and black and white setup adjustments
- Parts lists
- Wave forms keyed to test points for majority of chassis
- Top and rear chassis views
- Photos of typical receivers
- Index of models from CTC2 through CTC20
- Separate section on tuner schematics
- Separate section on remote tuner schematics

FIELD-SERVICE GUIDE

RCA COLOR-TV RECEIVERS

1955-1966

FEATURES

- Field Service Adjustments - 1955-1966
- AGC in Storage - CTC-10A
- Top and Rear Chassis Views
- Substrate Diagrams
- Voltage Waveforms Keyed to Test Points
- Isometric Section on Tester Schematics
- Parts Lists
- Comprehensive Index of Model Number, Model Name, and Chassis Number

See your RCA Tube Distributor today and arrange to get your copy.

RCA Electronic Components and Devices, Harrison, N.J. 07029



The Most Trusted Name in Electronics



5-13 33 H
MR DONALD D VAN DYKE
GOLDBERG CO INC
1905 WESTMORELAND ST
RICHMOND VA 23230

RCA Victor presents
 FRANK CONROY'S
 HOLIDAY SPECIAL
 NOV. 27 - NOV. 30

HARRISON, N.J.
 POSTAGE PAID
 PERMIT NO. 301475
 06