

GOOD NEWS

APRIL



VOLUME 2

MARCH

NUMBER 1

The secret of marvelous radio tone?

Insist on the radio tubes used by over 200 of the leading broadcasting stations



Phil Cook, the Quaker Man... you can't catch his flashy changes or the marvelous shades of his voice when you have worn-out tubes in your set. Replace them tonight with new RCA Radiotrons!

WORN-OUT TUBE

RCA RADIOTRON UY 227

Beware of Worn-out Tubes!

Even a single worn-out tube in a set of new ones can cause hum, distortion and poor tone! Remember—the eye can't tell the difference between a good tube and a worn-out tube. So tonight . . . take the tubes out of your set and have your radio dealer test them. They are as easy to remove as MAZDA lamps.

You can trust the leading broadcasting stations to use the best radio tubes. *They have to!* They dare not allow their radio programs to be marred by inferior tubes. And so over 200 of America's leading broadcasting stations use RCA Radiotrons, the radio tubes which leading radio manufacturers have recommended for years. When you buy a radio . . . be sure the tubes are RCA Radiotrons. And whenever you renew your tubes be sure to look for the RCA trade-mark . . . and the red and black carton.

RCA RADIOTRON CO., Inc.
Harrison, New Jersey,
A Radio Corporation of America Subsidiary

Tune in on the new RCA Radiotron Varieties on N. B. C. coast-to-coast network every Wednesday and Saturday night at 8:15 p. m., Eastern Standard Time.



RCA RADIOTRONS

The heart of your radio



This advertisement appeared in The Literary Digest, February 14; in Collier's, February 28 and will appear in the Saturday Evening Post, March 7, and in Liberty, March 14

GOOD NEWS

About RCA Radiotrons

C O N T E N T S F O R M A R C H 1 9 3 1

VOLUME 2 **25 Cents a Copy \$2.00 a Year** **NUMBER 1**

<p>The Enemy Attacks 2 By T. J. BERNARD, An Interview with COLONEL ARTHUR S. COWAN, Signal Corps, U. S. Army</p> <p>Free Tube Test Swells Sales Sixfold 4 By C. R. KLINGER, Pacific Sales Division, RCA Radiotron Company, Inc.</p> <p>The Big Noise Behind the Mike 6</p> <p>A Headliner's Merchandising Program 8 By T. F. JOYCE, Sales Promotion Dept., RCA Radiotron Company, Inc.</p> <p>Tuning In with J. W. McIver 10</p> <p>Keep Your Eye on Your Customer 11 By MILT GROSS</p> <p>Tube Testers—Assets or Liabilities? 12 By AARON KIPP, Commercial Engineering Dept., RCA Radiotron Company, Inc.</p> <p>Too Many Brands Spoil the Sale 14</p>	<p>2</p> <p>4</p> <p>6</p> <p>8</p> <p>10</p> <p>11</p> <p>12</p> <p>14</p>	<p>These Dealers Know It Pays 16</p> <p>Service Slants that Build Sales: Notes on Super-Heterodynes 18 By E. C. HUGHES, JR., Sales Promotion Dept., RCA Radiotron Company, Inc.</p> <p>The Road to Profit 20 By H. R. RUSK, Sales Promotion Dept., RCA Radiotron Company, Inc.</p> <p>Radio Tonics 22 By T. A. JOLLOFF and G. GERARD CLARK, Sales Promotion Dept., RCA Radiotron Company, Inc.</p> <p>Radio Tube Characteristics 24 By L. G. LESSIG, Commercial Engineering Dept., RCA Radiotron Company, Inc.</p> <p>A Little Imagination + a Little Effort = Windows that Sell 26</p> <p>Headliner Material 28</p>
---	---	---

WISDOM

KNOWLEDGE of the factors that contribute to the success of a profitable item is an indispensable tool in the mental work bag of every prosperous retailer. It is, in reality, the measure of his retailing wisdom.

In choosing the brand on which he is to concentrate—for merchants everywhere are confining their attention to one profit-making brand—the wise radio tube merchant takes into consideration such factors as margin of profit, customer demand, rate of turnover, consistency of sales and the character and aggressiveness of the manufacturer.

The testimonial of Ritter's Brunswick Shop, in Chicago—typical of many we receive daily—is a case in point. Their decision to concentrate on RCA Radiotrons is based on long experience with many brands. This type of letter, we submit, bespeaks not only the trend of the trade, but its inestimable good sense.

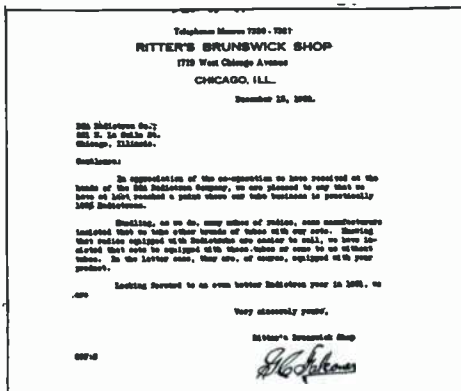

T. F. JOYCE Manager	T. J. BERNARD Editor	H. M. RUNDLE Art Editor	R. S. BURNAP Engineering Editor	W. W. CONE Circulation Manager	
EDITORIAL ADVISORY BOARD					
J. W. McIVER, Chairman	G. C. OSBORN	MEADE BRUNET	W. T. L. COGGER	W. H. THOMPSON	F. B. WANSELOW

A magazine of radio merchandising counsel to help distributors and dealers of RCA Radiotrons make more profit.
Published Monthly by RCA Radiotron Company, Inc., Harrison, New Jersey
Permission to reprint articles in this issue is cheerfully extended, provided proper credit is given. Copyright, 1931, by RCA Radiotron Co., Inc.



Colonel Arthur S. Cowan, the Commandant, the Army Signal School, and Commanding Officer, Fort Monmouth, N. J.

"SUPPOSE New York were attacked tomorrow," I said to Colonel Arthur S. Cowan, Commanding Officer, Fort Monmouth, New Jersey, "and your Signal Corps troops were called upon to furnish combat communication for the defenders; would radio play a vital part in that defense?"

"Under any conditions, we would be seriously handicapped without radio," declared the Colonel, "but its importance in such an emergency depends upon a number of factors.

"Any land action in which the Signal Corps would be actively employed assumes that the enemy had effected a successful landing, and in such a contingency, radio would be invaluable."

"How?" I asked.

Co-ordinating the Defense

"As a means of co-ordinating defense operations. Radio in the army is used as a means of communication between all combat units down to and including front line battalions and individual airplanes. In order that such communication might follow the proper channels of command, radio stations would be grouped into nets. A net is composed of a radio station of a higher unit, a station at each of the next subordinate units, and a station of any supporting unit. Each net has its own wavelength. If we were to visualize the passage of a

THE Enemy Attacks!

*Without Radio the Army Might Be Helpless
to Repulse an Invader*

By T. J. Bernard

An Interview with
COLONEL ARTHUR S. COWAN, Signal Corps, U. S. Army

message from Corps headquarters to Battalion radio stations, we would see it branch out in the manner of a family tree, as it was relayed from each higher to each lower unit."

"And the airplanes?" I asked.

"Plane to ground communication would be vitally essential if we were to maintain contact with and direct the fire of our artillery units," replied Colonel Cowan.

"That's radio telephone, isn't it?"

Telephone vs. Telegraph

"Yes. Telegraphy is not practicable in an airplane any more than it is in

ony has been highly perfected and is coming more and more into use."

"You mentioned tanks. Can radio be used effectively in them?"

The Colonel smiled. "Most assuredly. We developed the equipment for doing it right here in our laboratories. Ever ride in a tank?"

I admitted I had not.

"The clatter is terrific, especially in modern tanks, which develop a speed of up to twenty miles an hour. You can't make yourself heard to a man seated right beside you."

"That doesn't sound favorable to telephone conversation," I suggested



With hundreds of death-dealing enemy planes swarming overhead, the radio would do yeoman service in co-ordinating defense operations

a tank. We still use radio telegraphy almost exclusively, however, in our infantry and cavalry units, although in our more recent sets radio teleph-

doubtedly. "How do you do it?"

"Well," said Colonel Cowan, "it was a problem. Some said it couldn't be done. The trouble, of course, is

at the transmitting end—keeping the noise from drowning out the voice of the speaker. We got around that by using a microphone which would not vibrate below a certain frequency. The rumble of a tank in action, therefore, doesn't interfere with a normal speaking voice, which is of a higher pitch."



Signal Corps soldiers operating the SCR-77B field radio set, which is used for communication between front line battalions and their regimental headquarters

"How about an aerial?"

"We developed that, too. We use a flexible metal rod about 12 feet long that projects straight up from the top of the tank. A pair of counteracting springs at the base keep it from swinging like a pendulum after an obstacle has bent it over and it has snapped back into position. The set can transmit successfully up to nine miles.

Advantages of Radio

"We recognize the distinct advantages that radio enjoys and that situations arise in which it proves indispensable. It is practically instantaneous communication over long distances. It is independent of road conditions or traffic. Any enemy's command of intervening ground does not interrupt or prevent the establishment of radio communication. These are only a few of the reasons why we consider it of the highest importance, and why we give thorough instruction in radio to our students while in training at the Signal School here.

"The principal disadvantage of radio communication is that it is not secret. This necessitates the habitual use of cryptograms in transmitting dis-

patches. The enemy also is able, through its goniometric service, to determine the approximate number, types, and locations of our radio stations, and from this information and a knowledge of our radio organization, the enemy can estimate the organization and distribution of our forces.

The enemy can also deliberately interfere with our radio communication.

"Radio is also used by the Signal Corps for special purposes, other than communication. In a modern army such as would be used in the defense of New York, the Signal Corps would be charged with the goniometric location of enemy radio

stations and enemy airplanes, with the interception of hostile radio messages and with the interception of friendly radio messages for supervision purposes. Ours would be the responsibility of sending out press reports,

instrument that would have fitted into a cigar box with ease.

"Here's a little transmitter that is worth its weight in gold," he said, "It consists of a complete sending apparatus, including radio tube and flashlight battery. The whole thing weighs only 17 ounces. As it is carried upward by a cluster of small hydrogen-filled balloons, a radio direction finder is employed to tell the direction and velocity of the winds at various altitudes above the earth's surface. The information thus gained is of inestimable value to the Air Corps and to the Artillery.

Army Amateur System

"And while we're talking of any emergency, I might mention that we are mighty proud of the Army Amateur Radio System, which originated at Fort Monmouth. The key station is now in Washington, D. C. Sub-key stations are located in the nine Army Corps Areas. One night each week the amateurs are mobilized for duty; they communicate with the sub-key stations. When the amateurs have demonstrated their ability and reliability in keeping schedules they are given certificates showing they belong to



Destroyers laying down a smoke screen, a spectacular and effective feature of modern warfare

time signals, and meteorological information."

Colonel Cowan reached into a desk drawer and drew out a small

the army network. These 250 amateur experts thus in reality form a reserve corps which can be called upon in any emergency, military or otherwise."

Free Tube Test Swells

Sherman-Clay Draws Crowds with Plan for Promoting New Service

By C. R. Klinger, Pacific Sales Division, RCA Radiotron Company, Inc.

SHERMAN, Clay & Company, operators of one of the largest chains of radio-music stores on the Pacific Coast, have long enjoyed an enviable amount of tube renewal business. But neither Mr. Marsh, Radio Manager of the chain, nor Mr. Harold Rehmke, Radio Manager of the San Francisco store at Sutter and Kearny Streets, was satisfied. Their knowledge of the market and sound business sense told them it should be larger.

This year it was decided to make it larger. After a thorough study of all the present methods of selling tubes, a plan was adopted, and the Sutter and Kearny store, largest of the chain, was selected as the proving ground. The plan quickly graduated from the experiment class. In less than two months, it had multiplied RCA Radiotron sales by six!

As a first step, the company purchased a visual tube testing device that is large and impressive in appearance—an important point, according to Mr. Rehmke, since the entire plan was to be built around this testing instrument.

Next, a large quantity of pasteboard boxes, with an interior arrangement similar to egg containers, were made up—each one designed to hold eight tubes. On the top of each were printed complete instructions for removing tubes from the radio set.

The plan was now ready for trial. To introduce it, the tube tester was placed in



H. R. Rehmke, Radio Manager of the Sherman, Clay & Company store at Sutter and Kearny Streets, San Francisco, where the free tube testing plan was tried out

the store's largest and most prominent window, which was strikingly, yet tastefully, decorated with RCA Radiotron display material. A loudspeaker was installed above the window and connected to a microphone on top of the tube tester, to enable the operator in the window to explain each test to the people on the sidewalk.

In the course of his talk, the operator pointed out the fact that 70 per cent of

all radio troubles may be traced to old, worn out tubes. He urged the onlookers to replace their old tubes with new RCA Radiotrons, and invited them to take advantage of this new tube testing service—which was absolutely free. As an additional incentive, he offered each one a tube carrying carton and explained its advantages.

Sherman, Clay & Company have had a number of original window exhibitions—including marathon piano players—which packed the passers-by in front of the store. But seldom, if ever, have they been able so completely to stop the show. A typical crowd is shown in the illustration. Hundreds of persons who had never been in the store before were brought in to get one of the free cartons. Many returned to have their tubes tested.

The new service was also announced during the regular daily broadcast over a local radio station and by means of special post cards sent out to several hundred select customers, whose names were taken from the radio service files.

After a week in the window, where RCA Radiotrons are constantly displayed, the tube tester was moved to its permanent location in the new radio tube department on the first floor. The excellent arrangement of this department is shown in another photograph. In the glass case behind the counter is displayed the stock of several hundred RCA Radiotrons, which exercises



A typical crowd in front of the demonstration window

Sales Sixfold

a strong suggestive force while impressing the customer with the size and completeness of the tube stock.

Tubes brought in for testing are listed on a special slip and tested in front of the customer. On tubes that pass the test satisfactorily is placed a red sticker, giving the date and test reading. Every new tube sold receives a blue sticker. If the customer feels that his old set is not worth new tubes, he is immediately turned over to a salesman as a prospect for a new radio set.

In his energetic campaign to secure more renewal business, Mr. Rehmke has been ably assisted by his service department—the largest in San Francisco and one of the most up-to-date in the country. This corps of twenty experts not only knows its stuff, mechanically and electrically speaking,

but it possesses the aggressiveness and merchandising ability to account for a large percentage of the store's

of us have been getting our share of this highly desirable and profitable business. We have no one to blame but ourselves."

Mr. Rehmke has set about rectifying this condition in earnest, at least as far as he is concerned. "We have enlarged our exclusive RCA Radiotron department and are attempting to really merchandise RCA Radiotrons. In addition to window and store demonstrations, we use newspaper advertising, direct mail and the



The RCA Radiotron window in which the tube tester was demonstrated

profitable RCA Radiotron sales.

Years of experience have enabled Mr. Rehmke to form some definite conclusions with regard to the radio tube business. He believes in handling only one brand of radio tubes, for the simple reason that it prevents duplication of inventory and speeds turnover. His choice is RCA Radiotrons because his own experience has proven their quality and because public acceptance and demand for them is greater than for any other radio tube.

Mr. Rehmke is a firm believer in the possibilities of the tube renewal market; otherwise he would not have undertaken his latest—and highly successful—project. Says he: "The radio-music dealer of today who is not availing himself of this opportunity is overlooking one of the most promising developments of the radio industry. I will venture to say that entirely too few

telephone to tell people that we actually have something to offer—a service that is immensely valuable to every set owner. By rendering this super service we feel that we are building good will and creating confidence in the public mind. Results speak for themselves: we are selling six times the number of tubes we did before."



New radio tube department, on first floor, showing tube tester permanently located



Detail of window above. Note tubes tucked under right arms of Super Selling Fools

The Big Noise Behind



N. Ray Kelly, Sound Technician, NBC

WHEN out of the night and your loudspeaker comes the screaming whistle of fire apparatus, the rumble of distant thunder, the roar of the wind, the crackling of a fire, the chirp of a canary, the blare of a taxi horn, the heavy drum of a cloudburst, or the sound of waves gently breaking on a sandy beach, you know the genius of N. Ray Kelly, sound technician for the National Broadcasting Company, is at work.

Penthouse Magic

Kelly has invented and developed many machines for the reproduction of sound effects, and a few hours in his penthouse laboratory will soon have you believing that you have been in the yards of a great railroad or that you have just weathered a blustering storm.

The newest of Kelly's long list of sound effects is a simple wooden box, approximately three feet square. It contains a conglomeration of apparatus calculated to reproduce accurately the noises coincident with modern railroad operation. It is called the "one man railroad," and if all goes well, Kelly expects to have his latest "gadget" on the air during railroad programs within a very short time.

There are scores of sound effect devices in use on NBC programs, most

N. Ray Kelly, NBC's Sound Technician, is Past Master at Art of Deceiving Our Ears

of them invented by Kelly. But this versatile engineer admits that the "one man railroad" intrigues him most of all. It is his brain child, the favorite of a large and successful family.

Long Study Necessary

To capture accurately the chugs, the puffs, the hiss of steam exhausts, the clickety-click of rail heads, the shriek of whistles, the grinding of brakes, the clank of driving rods and other associated rail racket, Kelly spent hours at the Sunnyside, Long Island, yards of the Pennsylvania Railroad. The business of developing realistic sound effects for a nation-wide and critical audience is no haphazard job for this conscientious craftsman. Work, study, and experiment are necessary to success in this very interesting vocation.

While at the Long Island yards Kelly listened raptly to "booster" engines, Pullman cars, gondolas and other rolling stock. He stored away a knowledge of the conglomerate noises, he memorized the shriek of brakes and the scream of whistles. He timed the puffs of the locomotives and studied the clank of shifting switches. Not one detail of sound escaped his listening ears.

Array of "Gadgets"

But the "one man railroad" is only one of Kelly's developments. He points with pride to sound apparatus that clutters his lofty workshop. With a wave of the hand he will indicate an entire "garage" on a wooden board two feet square, to which are nailed a great variety of automobile horns, including the hair-raising fire department siren. By pressing a few buttons he can reproduce a fleet of taxis, the mad rush of fire apparatus, or the blaring horns of a New York theatre-hour traffic tie-up.

The bewildered visitor scarcely has time to make the acquaintance of the "garage" before Kelly blandly comments "Gosh, it sounds like a thunder storm outside," and sure enough, *whango!* goes the roar and rumble of celestial artillery. The visitor has just come in from the sunny, snow covered streets and his amazement is relieved only when Kelly shows him the big "thunder drum," a four-foot frame across which heavy parchment is tightly stretched.

More Revelations

Kelly next pulls a cord running through the skin-covered bottom of a pail, giving a very terrifying imitation of a lion's roar; whistles blow in realistic imitation of a dozen different birds; a threshing machine bangs and rattles as



A locomotive gets under way

a bit of intricate machinery and a baby's rattle are agitated.

Sometimes Kelly conducts his visitor to a vacant studio, arranges a microphone and escorts his guest into the glass windowed monitor room. Returning to the studio microphone, Kelly

the Mike

crumples some stiff paper before the open end of the "mike" and the visitor is surprised to feel himself transported to the side of a crackling fire.

Still standing before the microphone



Rifles crack and pistols bark

Kelly taps his head with a padded stick and the onlooker is ready to swear he has heard a dog thumping his tail. In fact many people do swear it. We hear rifle or pistol shots. But it is only

Kelly striking a padded board with a flat stick, as he explains quite seriously that shell explosions and the actual use of machine guns might completely wreck expensive studio equipment.

Wild Sounds Domesticated

The creaking of a porch swing is reproduced by gently rocking back and forth in an old rusty swivel chair placed before the "mike." Animals are heard crashing through the underbrush when Kelly squeezes the straws of a household broom, and steady rain sounds when excelsior is rubbed against the microphone face. A torrential downpour is effected by pouring salt on wax paper held before the "mike."

Many Sound Effects Produced by Accident

"Many sound effects are obtained by sheer accident," Kelly explains. And to carry out this statement he cites that particular occasion when an announcer stood absent-mindedly rubbing his fingers across the teeth of his pocket comb and developed the mournful notes of a tree toad.

The gentle washing of lazy waves along the ocean front is reproduced by a circular wheel with an eight-inch hollow rim covered by copper screening, inside of which rolls a handful of

one. It is merely a battered wash boiler filled with assorted junk and equipped with a small electric motor, to the shaft of which are attached several pieces of leather strap. As the motor runs, the boiler is shaken by hand and the leather straps beat against the debris. It really sounds like a 1913 Ford trying to come down the street.



An airplane's distinctive drone



NBC Sound Laboratory. In the rear, the "Thunder Drum"

hard-dried peas. As the wheel is turned the peas swish against the screening. Rapid turning of the wheel, interrupted by sudden stops, simulates pounding breakers.

The wind machine is probably the best known device. It consists of a canvas sheet laid over a paddle wheel winch. As the winch handle is turned the paddles beat against the canvas. At high speed the sound is like that of a howling gale; at low speed, perhaps a gentle summer breeze. Winds in all degrees of velocity are reproduced on this machine and storms have been created that have put nature to shame.

Kelly has a broken-down automobile in the NBC laboratory. It is not a real

at varying speeds ranging from the slow, uncertain sputter of warming motors to the high-pitched drone of the take-off.

Many modern programs must have their airplanes. Consequently, another use of straps is to reproduce the hum of airplane engines. An electric motor whirls leather straps against drum heads

Master of Singular Profession

Ray Kelly declines to estimate the amount of sound effect apparatus operated by NBC, explaining that the tendency is to continually improve the devices and lay aside obsolete equipment. He constantly endeavors to bring different sound effect developments to a "one man operation" basis, rather than employ several men for a single effect.

Truly, Kelly is a master of a singular profession—part naturalist, part musician and part engineer.

A Headliner's Merchandising Program

Store Organization and Operation

By T. F. Joyce

Sales Promotion Dept., RCA Radiotron Co., Inc.

A FEW weeks ago I had the opportunity of studying the business of a radio retailer who in 1930 did more than \$100,000 worth of business, yet lost almost \$10,000. Certainly, a dealer doing that volume of business has no excuse for losing money.

This case was interesting to me. Here was a man who was losing money not because he wasn't selling enough merchandise, not because he wasn't carrying the right kind of merchandise, not because his gross margin wasn't sufficiently large to cover normal operating expenses, but because he lacked organization and proper control over store operations and expenses.

An analysis of all retail failures shows that approximately 42 per cent are due to causes which can be directly attributed to poor management. In addition, 35 per cent of all retail failures are chargeable against lack of capital which, indirectly, is a sign of poor management. The successful retail store makes money because it is organized and operated with that end in view. Merchandise, equipment and personnel are organized and directed toward the accomplishment of that objective.

Most retail organizations are "one man" organizations. The owner or manager tries to do everything himself. He accepts the responsibility for everything from keeping the sidewalk clean to closing a \$500.00 sale. Organization is necessary even where only one person is involved. In that case, however, it is organization of the work to be done, and not of individuals.

Where two or more people are

involved, organization of work as well as personnel, is essential for purposes of efficiency and accomplishment. Prob-

expected and should be made. If the organization is smaller than that diagrammed, the work can be assigned to those who are in a position to take it over.

The organization of the retail store activities involves:

1. *Maintenance of store and equipment.* On the type of store in which the business is conducted depends, to a degree, the success of the business. It must be kept in good condition, the surroundings both inside and out should be pleasant and conducive to making sales. Store equipment, fixtures, delivery services, etc. must be kept up-to-date and in working order.

2. *Receiving merchandise.* Merchandise is received from wholesalers and manufacturers. Before being accepted it should be checked against bills of lading, express and truck receipts, etc. Merchandise should be checked for quantity, quality, damage, etc. If profit leaks are to be stopped—the first place to stop them is at the receiving door. Don't let them get into your store.

3. *Store supplies.* To conduct a retail business certain supplies are necessary, such as: wrapping paper, boxes, price tags, service department tags, etc. While the total expenditure for this material is not large, yet it is of sufficient importance to be segregated from other operations and set up accordingly in the store budget. Both the purchase and use of this material should be carefully watched, for every nickel saved here represents that much more in the net profit column.

4. *Protection of merchandise and equipment.* Radio merchandise is valu-

A Headliner's Merchandising Program

Below is an outline of the articles which will appear on this subject. The General Outline appeared in the February issue.

1. General Outline
2. Store Organization and Operation
3. Sales Quotas, Stock Limits and Merchandise Lines
4. Buying
5. Selling
 - a. Retail Salesmanship
 - b. Outside Selling
 - c. Display Selling
 - d. Advertising and Store Promotion
6. Service Department—Organization and Operation
7. Accounting and Control
8. Operating Expenses
9. Salaries, Wages and Commissions
10. Financing Set Sales

ably in no other line of business is organization more vital than in radio retailing. Radio retailing operation involves many different functions, each of which is highly specialized and requires trained services for maximum results.

What are the various divisions of work in a radio retail store? What are the various tasks which can be assigned to different individuals and for which they can be held responsible? In connection with this article we have prepared a chart, for an average radio store, adapted from a small store organization chart made by the National Cash Register Company. This shows the divisions of work which can be

able. Dishonest customers and employees must be watched, particularly when handling radio tubes. It seems to be taken for granted that it's no crime to steal a radio tube. A system to protect the store against such losses is important.

5. *Employees.* Most of the problems in connection with the operation of any business enterprise are those which concern the employees. The store personnel must be properly trained and know what is expected of it, if the store is to function smoothly. People must be fitted to their work and work to the people.

6. *Buying.* Merchandise and supplies must be purchased. Buying is one of the most important functions of the store management.

7. *Selling.* Merchandise must be sold, for no matter how well a store may be organized, sales must be made if it is to continue to operate. All other functions are subordinate to this one.

8. *Advertising.* In modern retailing advertising plays an important part. Money spent for advertising without a knowledge of how to use advertising, is just so much money thrown away. It would be better not to advertise.

9. *Service.* In no business is service of more importance than in radio. A radio set is still, and probably always will be, a highly technical and

complicated piece of apparatus about which the average person knows little or nothing. The ultimate satisfaction of the customer depends upon the store's having a good service department, rendering efficient service to customers.

10. *Finance, accounting and control.* Money is needed to operate any business, including radio retailing. It is absolutely essential that the manager know where he stands from day to day, week to week and month to month. This is impossible without a good accounting system.

11. *Office routine.* A certain amount of office work is necessary in a retail business. This includes the handling of correspondence, mailing lists, etc. Proper office organization can be helpful in the conduct of the store and particularly in increasing its operating efficiency.

Results of Organization

With proper organization, nothing capable of human accomplishment is impossible. Organization results in a specialization of effort. People do best those tasks which they like to do and which they know how to do. The more specialized an individual becomes in one type of work, the more efficient he or she becomes at it.

In radio, a good service man is seldom a good salesman. The outlook

and views of a salesman are entirely different than those of a service man. To be certain, one can help the other, but neither can supplant the other.

Organization makes possible the assigning of work to individuals and holding them responsible for it. Most people shun responsibility, but once they are taught to assume responsibility, they become more valuable employees. Then, they think as well as work. They, too, become vitally interested in the question of store expenses, sales and profits.

Proper organization results in better training of the store personnel, closer supervision and a co-ordination of effort.

Organization assures the future growth of a store. With organization the store does not have to depend upon one individual. The organization goes on. This gives to the store a factor of permanence which it would not otherwise possess.

With right organization and a diversification of responsibility, it becomes possible for the owner or manager to devote his time to the larger and more important aspects of his business. Then he has time to expand and develop his business, to adequately supervise his employees and encourage them in their work. Everybody is happier and everything runs smoother.

RADIO STORE ORGANIZATION

Manager or Owner	Head Salesperson	Second Salesperson	Outside Salesman	Service Manager	Service Man	Bookkeeper
Supervise buying selling displays advertising service credits delivery office	Sell merchandise	Sell goods	Arrange calls	Keep service equipment in proper condition	Make proper installations	Keep accounts
Watch departments	Supervise and train salesmen	Look after stock arrangement	Keep live prospect list	Route service men	Restore sets to original operating conditions	Receive bills
Analyze check records	Assist in buying	Report slow moving merchandise	Sell sets	Train service men	Build good will for store	Issue bills
Watch for leaks	Watch credits	Report stock shortages	Sell tubes	Inspect new sets	Furnish leads for set sales	Pay bills
Control expenses	Plan advertising	Check invoices received	Arrange for demonstrations	Check set installations	Make collections	Receive cash
Plan business ahead	Check up price changes	Check outgoing merchandise	Make collections	Back stop for service man	Sell sets	Deposit cash
Cultivate trade	Look after window and interior displays	Keep store, stock and shelves clean	Check to see if customer is satisfied	Advise on buying	Sell tubes	Keep pay roll
Sell merchandise	Turn leads over to outside salesman	Keep price tags clean		Sell sets	Report complaints	Keep records
Study competition	Demonstrate sets	Put up rush orders		Sell tubes		Answer telephone
		Keep up stock		Turn in prospects		Handle correspondence
						Prepare balance sheet
						Prepare profit and loss statement
						Supervise taking of inventory

TUNING IN

With J. W. McIver

Manager, Sales Promotion Department

THE causes of most sales resistance (assuming a good value) are poverty and ignorance; ignorance on the part of the buyer.

You wouldn't expect a savage to understand why he would be expected to pay more for an article marked "Sterling" than for an article of similar appearance which was plated. He wouldn't pay more for caviar than for shad roe. They would be just a lot of fish eggs to him. Nor would he be suffused with ripples of appreciation if he found himself surrounded with broccoli, rather than spinach. The values would have to be established.

We wouldn't expect him to demand RCA Radiotrons. But, we would expect to teach him the value of a quality product, familiarize him with the mark that would identify that product and keep him reminded that he should buy it.

TRADE marks and trade names originated in human vanity. Men of exceptional ability have always liked to put their names on their creations. Trade marks are old. Saucers and bowls 4000 years old, bearing the marks of the proud potters, have been found.

These symbols or marks, frequently drawn because the gifted maker couldn't write, soon grew to have commercial value. Customers found that articles bearing certain marks had a pleasing consistency of superlative workmanship. While trade marks and trade

names still mean that the makers are proud of the products, their greatest importance, today, is in providing an immediate standard of value to the public.

More and more the public depends upon a few names, a few words for guidance in buying. All I want is the quickest, simplest means of identifying the product and the merchant which I have found to be satisfactory. I haven't time, the hours are too crowded, to assay and measure every single article I purchase or every merchant I meet.

Every business dealing should be conducted toward the objective of bringing that customer back again. It can be illustrated easily.

RECENTLY I was making a purchase in a drug store when I saw a razor blade display. I asked for Gillette blades. The druggist appeared to dive for them but came up with a strange package. He asked me if I had ever tried the Jingo blade. I promptly told him that I had not, had never heard of them and wanted, at once, a package of Gillette blades. Simply that, nothing more. The druggist ignored me and whirled into his story of why he recommended this strange blade.

He told me that he used them. That he recommended them, that he sold a lot of them, that he—but why go on?

I told him to forget the

blades, to wrap up my other purchases, that I would buy the Gillette blades somewhere else, where they would let me have what I knew and wanted.

"Wait a minute," he cried. "I have them here. (He had them hidden in his hand). I merely wanted you to try these other blades. You don't know anything about them."

"Oh, yes, I do," said I. "I know all about those unknown blades. They are long on discounts and short on shaves."

He watched me with surprise as I left the store. He didn't know it, but, deluded by the fanciful and imaginary extra discount, he had lost other sales, had convinced me that I shouldn't return there again, had wasted a lot of valuable time for both of us, had kept others waiting and had seriously damaged the reputation of his store. He was working for a theoretical pay, doing the work the manufacturer should have done for him.

A GOOD name is a priceless thing. It takes time, care and money to build. Everything we do should be done with the idea of obtaining a firm foundation for future building. The actions of today should be the support for the good things of tomorrow.

Every merchant knows what he should do to build up a successful business. The bed rock is a good name. The only value a good name can have is the value it has when it grows to represent good value.

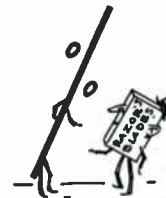

Keep Your Eye on Your Customer—

By MILT GROSS

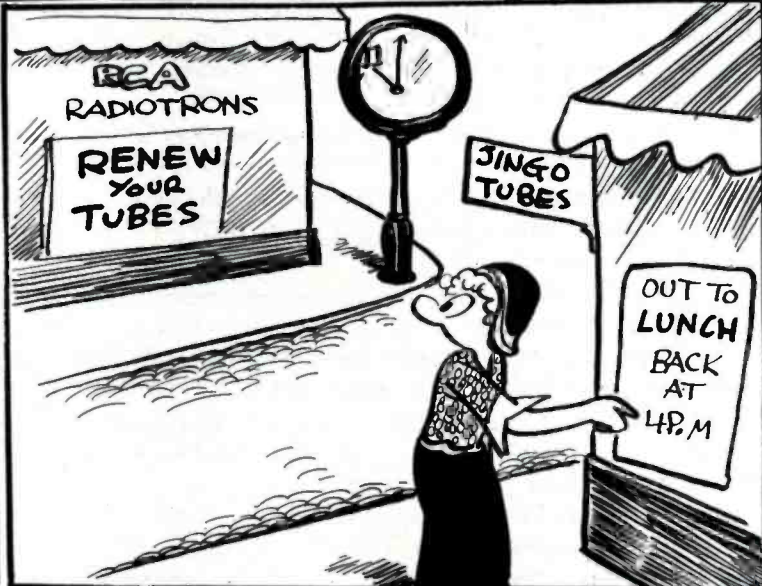
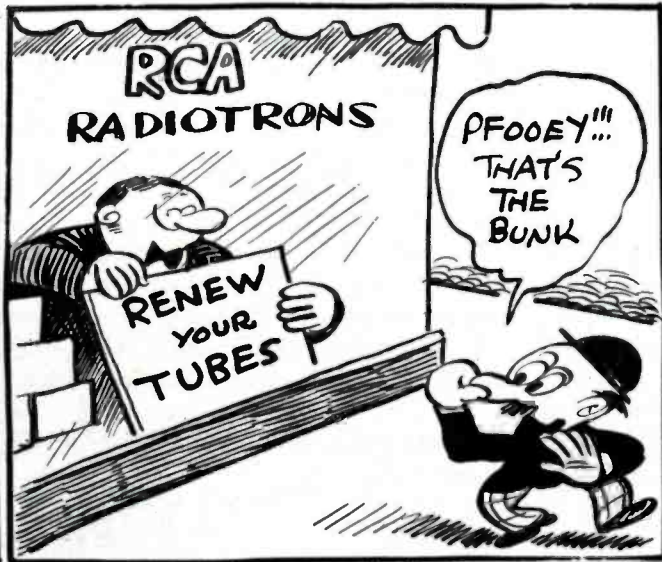

Tube Testers— *Assets or Liabilities?*

By Aaron Kipp

Commercial Engineering Dept., RCA Radiotron Co., Inc.

EVERY wide-awake radio dealer now has some form of tube tester, because of the business-getting ability of an instrument of this kind. It is a well known fact that, of two dealers selling similar merchandise, the one with the better service facilities for his customers will have the larger income tax to pay.

The purpose of any tube tester is, obviously, to determine if a given tube will operate satisfactorily in a radio set. Tube testers, at best, merely approximate the operating conditions within a radio set. The closer the tester approximates set conditions, the more valuable the test. In other words, testing a UX-245 with the rated 250 volts on the plate and the correct bias will be a more accurate test than when only 90 or 100 volts on the plate are available from the tube tester.

Only One or Two Factors Checked

Commercial testers must necessarily be simple to operate so that there is little danger of non-technical persons using them incorrectly. They must be moderately priced if a large market is to be developed. Because of these factors, most testers now available to dealers check only one, or at most two, operating factors. One of the most important single factors in determining whether a tube will operate satisfactorily in a radio set is its mutual conductance value. Hence, the latest tube checkers make some form of mutual conductance check on the tube under test.

Some light on the real meaning and worth of mutual conductance values is not out of place at this time. Mutual conductance, theoretically, is equal to the amplification factor divided by the

tube, up to a certain value where the sensitivity and volume output are unsatisfactory for normal operation. When this value is reached, the tubes should be replaced with new RCA

Radiotrons. It is clear, therefore, that RCA Radiotrons must be manufactured within definite limits of mutual conductance in order to give satisfaction. If the mutual conductance is higher than the limits used by the designer, the radio receiver will probably oscillate and give unstable and unsatisfactory results generally. If, on the

other hand, the mutual conductance becomes lower during life than that for which the set has been designed, insensitivity and falling off of volume will be noticed.

Direct Reading Method

Most of the leading set manufacturers design their receivers to RCA Radiotron standards. Tubes with a higher mutual conductance value than corresponding Radiotron types, when used in receivers designed for Radiotrons, may give unstable operation and oscillation of the set, even though a mutual conductance tester indicated superior results.

There are two general types of mutual conductance tube testers now on the market which operate from a 110 volt A. C. source. Some employ a rectifier system, using a UX-280, to supply D. C. voltages to the plate and grids of the tube. The filaments are heated with the correct value of A. C. voltage and an A. C. signal voltage, corre-

What A Good Tube Tester Will Do.

1. Pick out worn-out or "low" tubes.
2. Indicate "shorted" or "burned-out" tubes.
3. Build up confidence of the customer.
4. Save time in service work.
5. Make money for you.

What A Good Tube Tester Will NOT Do

1. Pick out small variations in tube merit.
2. Indicate a noisy or "humming" tube.
3. Determine actual time that a tube has been in service.
4. Replace the service man.

plate impedance or A. C. resistance of the tube. The two terms that go to make up mutual conductance are, in turn, governed by such things as the spacing and size of the elements within the tube, the degree of exhaust, the kind of materials of the parts, and the voltage conditions under which the tube is to be operated. The mutual conductance value of a tube, therefore, varies with the design and purpose of the tube. For a given type of RCA Radiotron designed for a specific use, mutual conductance values are a satisfactory indicator of merit.

Designers Must Know Characteristics

If radio receivers are to be satisfactory and efficient, the designers of such equipment must know the standard characteristics of the tubes to be used in the set. When these characteristics are known, provision can be made in the receiver design for the gradual falling of the mutual conductance characteristic, due to use of the

sponding to the radio signal voltage in a receiver, is impressed on the grid of the tube. A special meter in the plate circuit then indicates the power output of the tube under test. This meter may be calibrated to read directly mutual conductance in micromhos. These values may be confusing to the dealer, who ordinarily does not know that they do not necessarily correspond to published values of mutual conductance except when the tester voltages on the filament, plate, and grid are exactly the same as those under which the published mutual conductance values of Radiotrons were obtained. When this distinction is appreciated, this general type of tester has considerable merit for comparative results.

Grid Shift Method

The other general method is usually referred to as the grid shift method. This consists of applying the correct A. C. voltage to the filament, line voltage to the plate, and two different values of voltages to the grid which are at the control of the operator. A meter in the plate circuit indicates the self-rectified plate current of the tube under test. This meter is read at the two different grid voltage conditions and the difference noted. This difference in plate current is the mutual conductance indication and can be considered as the

merit indication of the tube. This type of tester, where a fixed value of grid shift voltage is applied and where the meter scale is properly chosen, has been found to give reasonably accurate indications of tube performance.

Some Meters Misleading

Some tube testers make use of large meters with fine divisions in order to suggest accuracy to the dealer or the customer. This is misleading and gives a false accuracy to the instrument. It has been found from months of testing tube checkers that only moderate accuracy is incorporated in the best of such equipment. That is, tubes of 10-20 per cent difference in their real mutual conductance values may not show an appreciable difference in readings on the checker. On the other hand, tubes of the same real mutual conductance may show 10-20 per cent shift in the tester indication. Only when differences of 30-50 per cent in the real value occur does the tube checker indicate significant difference in tube performance.

It is obvious, therefore, that a tube checker has little value in comparing new tubes and should ordinarily not be used for this purpose.

Some testers attempt to grade tubes into a number of classes. Due to the practical limitations of most testers,

this grading is subject to serious errors. Our experience indicates that the limits proposed for different tubes are usually too stringent. Through general receiver experience and from a knowledge of the kind of receivers in his district, a dealer frequently can set limits fairer to everyone concerned.

RCA Radiotron dealers are writing us for suggestions as to the type of instrument they should buy for their testing equipment. After months of investigation in testing commercial equipment, the following requirements for a practical tube checker have been established:

Requirements for Practical Checker

1. Some form of mutual conductance test.
 - (a) Direct reading.
 - (b) Variation of fixed grid bias values.
2. Easily readable scale deflections for all tubes.
3. Adjustment for line voltage variations.
4. Rugged construction.

When used with the proper choice of rejection limits, tube testers which meet the above requirements are a real aid to the dealer.

Additional articles on the subject of tube testers will appear in later issues of Good News.

Can These Be Compared?

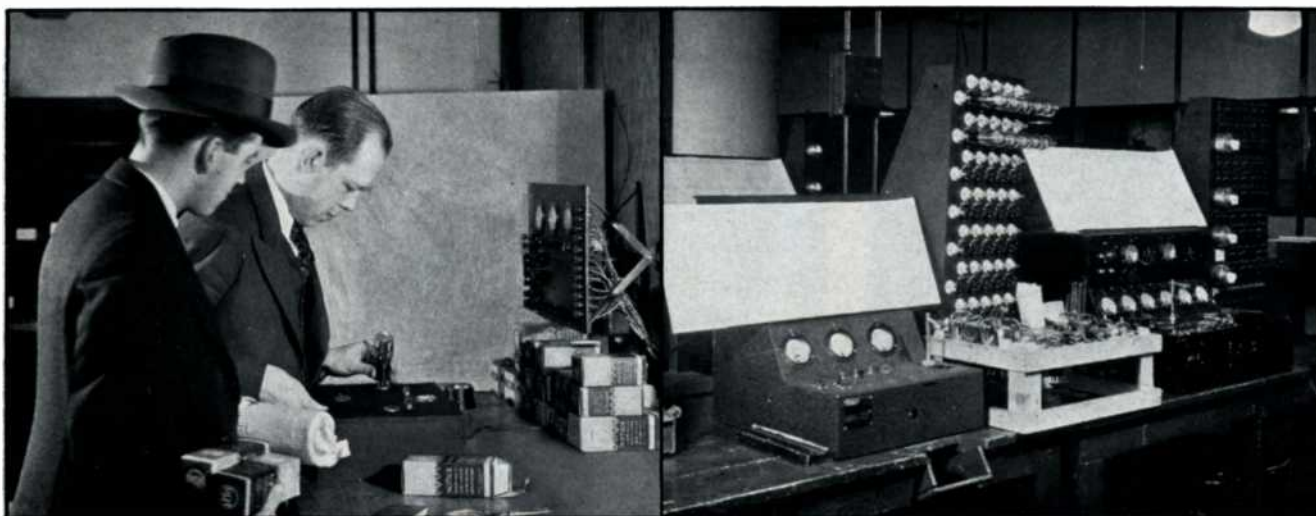

This type of tube tester is in common use among dealers. Dependable as far as it goes, it provides only one check on the merit of the tube. Cost, less than \$100

Actual equipment used in RCA Radiotron Service Stations for testing returned tubes. Provides over nine different checks for each tube. Cost, over \$3,000

Too Many Brands



1. This retailer has a large number of brands to handle. He must divide his attention among all of them



2. If the retailer is unable to distinguish between various brands, how can he expect the customer to have confidence in his judgment?



3. A conclusion that one is apt to arrive at if the question is not given serious consideration. Can you discover the fallacy?



7. The dealer who pushes an unknown tube is wasting his own valuable time as well as that of the customer



8. Time spent trying to sell unknown products can be more wisely and profitably invested in other directions



9. The line of least sales resistance is always the quickest road to profit



13. Thanks to RCA Radiotron advertising, the customer is already in the desired frame of mind. The salesman carefully fosters it



14. With the Socket Layout Guide always at hand, he is able to tell her instantly the tubes used in her set



15. Points out the benefit the customer can expect by changing all tubes

s Spoil the Sale



4. The individual who resents having his statements challenged is usually not in a position to back them up with facts



5. The customer has probably seen RCA Radiotron advertising. The one-brand salesman would know how to take his cue



6. But this salesman, who has many brands to push, foolishly goes off on another tack, thus jeopardizing the sale



10. Trying to sell the customer what she doesn't want usually results in lost sales



11. An attractive window featuring just the product she wants is particularly appealing to the customer



12. The successful retailer senses a prospect and immediately paves the way for a complete renewal sale



16. Showing the customer her patronage is appreciated. A word of thanks and an RCA Radiotron Broadcast Station Directory



17. This dealer's knowledge of retailing and his intelligent, tactful handling of customers brings its own reward



18. The whole story in a nut shell

These Dealers

*By Supplementing RCA Radiotron Sales Aids with
at the Goal of Every Wide-awake*

RCA Radiotrons Help Sell Sets

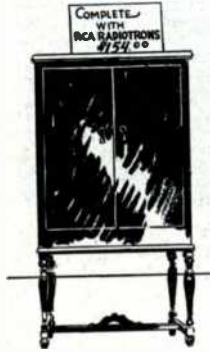

The Good Housekeeping Shops in Detroit are actively merchandising RCA Radiotrons and as one feature of their work they advertise in the newspapers that their sets are delivered equipped with them. Mr. Ryall, the Radio Department Manager, says this is done because of customer acceptance and demand. As an example he cites the case of a person who bought a set from a competitor. When the set was delivered it was not equipped with RCA Radiotrons so the customer immediately sent the set back and ordered one from a Good Housekeeping Shop because she knew it would come with RCA Radiotrons.

65% Increase

Cluett and Sons, dealer in Albany, New York, started specializing on RCA Radiotrons on January 19. In two weeks RCA Radiotron sales had increased 65 per cent.

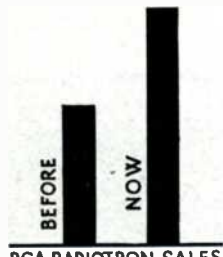

Here is their plan of action: On alternate weeks they give RCA Radiotrons an exclusive window. When not in an exclusive window RCA Radiotrons are made a part of a set window. One man has been given the job of checking all sets that have been in customers' homes for a year or longer. All salesmen receive a 5 per cent commission on RCA Radiotron sales. In actual practice most of the selling by these salesmen is over the

telephone. They call a customer and ask if the radio is working satisfactorily. If it is not, a service man calls and checks the tubes.

Service

Appleton, Wisconsin, is blessed with a real, live wire, efficient radio service organization. It's the Central Radio Service, owned and managed by F. J. Harriman.

HARRIMAN RADIO NEWS
Published by HARRIMAN RADIO SERVICE
Phone 665-4 413 N. Clark Street, Appleton, Wis.

Radio Tube Headquarters Tube Testing

RADIO BROADCAST EVENTS

<p>No Advertising On The Air in England</p> <p>The B.B.C. of the British Broadcasting Corporation is to make its 114-piece orchestra the finest in the world, to serve as a world-wide advertisement on the air. It will not be long before listeners in San Francisco or the Far East will say "I cannot miss hearing the British Orchestra." More than \$400,000 will be spent on this orchestra in 1931, according to The Daily Mail. The British Broadcasting Corporation plans to spend approximately \$6,000,000 on broadcasts this year.</p> <p style="text-align: center;">Radio Tube Headquarters HARRIMAN RADIO SERVICE 413 N. Clark St. Phone 665-4</p>	<p>Television Made More Life-like With New Improvements</p> <p>Several new developments in electrical research have pushed television one step nearer to the talking motion picture in clarity and simplicity. Each improvement moves the camera toward the home.</p> <p>The cumbersome electric arc light heretofore employed in most television systems has been abandoned. It has been replaced by a powerful incandescent lamp. An another marked improvement is the new lamp, instead of casting a pale orange glow, now throws a powerful beam of light which instantly paints the image or scene on the screen. And the use of the whirling disk has been fitted with sensitive two camera lenses that concentrate the beam's light to give the moving picture greater contrast. No longer are the scene rays scattered and feeble. These advances enable the engineers to build a television set of half the former size. Talk with your dealer about the experts call "definition."</p>
---	---

Mr. Harriman's activities reach out to dealers for a radius of 60 miles around Appleton. It is said that this organization does radio service work for more dealers than any other organization of its kind.

Of course, the growth and prosperity of the Central Radio Service is built upon good service to dealers and to the dealers' customers. One very good idea used by Mr. Harriman is free individual stickers, for every dealer served. Whether tubes are tested for the Clement Radio Company, Rimmel & Rimmel, the Leader Hardware or Carl Hassel each tube receives a sticker with the name of the dealer and shows whether the tube is satisfactory or

should be renewed.

Another novel stunt used by this wide-awake service organization is the printing of a small four page sheet which is full of radio news and merchandising information. For example, in one of the last issues of the *Harriman Radio News* is a short story regarding the purchase of a Radiola by John D. Rockefeller.

With such aggressive methods it is little wonder that the Central Radio service and F. J. Harriman are prosperous.

Insuring Future Business

Mr. Philip Werlein of New Orleans thinks so well of the RCA Radiotron brass set name plate that he is inaugurating the following plan in each of his five retail stores:

A service man, or inspector, will call at the home in the evening after a new radio has been delivered. This inspector will ask the owner, preferably the lady of the house, if the set is operating satisfactorily. If so, he will then produce the brass set name plate, give the owner a short talk on the advisability of changing tubes at least once a year, and tack the name plate in the set, in the presence of the owner, with instructions to watch the date carefully.

Remind Them to Buy

Some time ago a customer walked into the Plattner Electric Company in Toledo and asked for a flashlight lamp. She noticed a Selling Fool on the counter and, picking it up, began asking questions. She remembered that she needed a new tube for her radio. Mr. Plattner pointed out that "all at



Know it Pays—

*Ideas and Plans of Their Own They have Arrived
Merchant More Profits*

once is the best way" to change tubes. The customer agreed and asked for a service man to call the next day. Mr. Plattner then pointed out that it is very easy to change the tubes in a radio, so the lady purchased her complete renewal on the spot.

Potent Advertising

According to S. B. Curren, salesman for the Klaus Radio and Electric Company, Peoria, Illinois, Quaker Products Company in Galesburg, is getting remarkable results from newspaper advertising. A single insertion of the advertisement shown here resulted in the sales of 243 tubes and five sets.

Mr. Linstrom is running the ad once every two weeks.

Easy to Sell—And They Stay Sold

Escorad Inc., one of Chicago's oldest and largest service organizations, says, "From time to time numerous radio tube salesmen have asked us why we buy and use only RCA Radiotrons, when there are so many other tubes on the market that can be purchased cheaper. Our answer is: 'RCA Radiotrons do not need long explanations. They sell themselves!'"

This is Selling!

Cohen's Department store in Jacksonville, Florida, is fortunate in having an aggressive sales lady in its radio and record department. This young lady, Miss Aldredge, talks complete renewals to every customer who comes into the department.

One of the reasons for her success is that she always suggests a complete renewal of RCA Radiotrons and not just a renewal of tubes.



The RCA Radiotron business of this store has prospered so well that regular window displays are now being used. Selling Fools are constantly at work in the windows and inside the store. RCA Radiotron transfer strips decorate the RCA Radiotron show case. Newspaper advertising tells customers to bring in their tubes for free testing and receive an RCA Radiotron

A NEW
**Radio Inspection
Service**

AGAIN THIS WEEK we will call at your home and test all your radio tubes, voltages and make a general inspection of your entire radio and aerial system for—

50c

GALESBURG'S OLDEST RADIOLA DEALER

offers you this service for a limited time only on radios of all makes and types. No doubt, as you sit and listen to your radio, you have often wondered whether or not you had a weak tube or if indeed that the tone wasn't quite what it used to be. It's worth 50 cents to know. Years of experience, expert knowledge of radio circuits, and up to date equipment make it possible for us to analyze your entire radio system quickly.

PHONE US NOW

Get your call in immediately. Under the satisfaction of dealing with a concern that really knows radio, specializes in it and has modern equipment. Remember a phone call brings no charge.

QUAKER PRODUCTS CO.

GEO. C. LINDSTROM
Phone 5326 Main 220 E. Main

Broadcast Directory. RCA Radiotron price lists are included in every package leaving the store. Mr. Bibb, the radio manager, has many other ideas which he plans to put into operation in the near future.

RCA Radiotrons—The Leader

The manager of the Georgia Power Company store in Hapeville, Georgia, attributes the sale of a new radio and a refrigerator to the RCA Radiotron sign "Bring In Your Tubes and Have Them Tested Free." A customer brought in his tubes for testing and the manager took this opportunity to demonstrate a new set. A sale resulted. The manager then demonstrated a refrigerator. This resulted in a sale for Spring delivery.

Barber Shopping

The Jamison Radio Shop in Sandusky, Ohio, is trying out a novel scheme. This dealer is placing RCA Radiotrons on consignment in barber shops. It has been suggested that the ceiling of the shops be used for reminder advertising.



A Real Lesson in Merchandising

A certain prosperous hardware store in Detroit had been handling RCA Radiotrons and other nationally known and recognized products. Then the store changed hands and the new owner, deceived by the mirage of the long discount, discontinued RCA Radiotrons and other well known lines. As a result sales began to decrease and now it has been necessary for the original owner to take the store back. This present owner is a business man and a merchant. He has signed as a Headliner Dealer and is going back to nationally advertised merchandise in an effort to rebuild his once prosperous business.

Promotion to the Point

Last fall the Williams Bennett Company of Greensboro, North Carolina, obtained permission to demonstrate a new radio set in the public schools. At each demonstration, RCA Radiotron pencils were given to the pupils. The theory behind the gift was that the children would take the pencils home where many potential customers would have their attention directed to RCA Radiotrons.



Service Slants that Build Sales . . .

Notes on Super-Heterodynes

By E. C. Hughes, Jr.

Sales Promotion Dept., RCA Radiotron Co., Inc.

WITH the advent of the super-heterodyne circuit into general use by radio set manufacturers, the service man will be called upon, more and more frequently, to service this type of receiver.

Due to the fact that the adjustments on super-heterodynes are somewhat different from those on tuned radio frequency receivers, it is desirable that some of the differences be pointed out to the service man. The sensitivity and selectivity of the super-heterodyne can be obtained only when the receiver is properly adjusted.

Service Methods Vary

It is not the purpose of this article, however, to give specific details on the method of servicing super-heterodynes, since methods will vary with different manufacturers. It is intended to point out to the service man things which should be carefully watched and the importance of following closely the service instructions of the manufacturer.

Altogether too little attention is given to the manufacturer's service notes. Too often, the service man never sees them. This is unfortunate because manufacturers supply service notes with a view toward helpfulness and accuracy. Familiarity with them not only saves time and effort, but is essential to good work.

To many service men, the word super-heterodyne signifies extreme sen-

sitivity and selectivity, but some do not understand why. A brief discussion of super-heterodyne operation and the circuit's advantages is, therefore, not out of place.

In general, radio frequency amplification can be employed more efficiently and successfully at fre-

the outgrowth of the need for a method of amplification that would get around these difficulties.

Intermediate Frequency Detected

In the super-heterodyne circuit we have an oscillator tube which generates a signal of different radio frequency from that of the signal we wish to receive. This signal is combined with the incoming signal to produce a third frequency which is equal to the difference between the two. The formation of this third, or intermediate frequency, as it is known, is due to the phenomenon of "beating." The intermediate frequency is then detected by the first detector tube and fed into intermediate frequency amplifier stages. Thus, we obtain for further amplification a lower frequency than that of the incoming radio signal. Since the intermediate frequency is fixed, the design of a circuit to give higher amplification is comparatively easy.

In some receivers, the incoming signal is passed through one or more stages of radio frequency amplification before it is fed to the first detector.

The Second Detector

After the intermediate frequency has been amplified by as many stages as desired, it is fed to the second detector. The resultant audio frequency is then amplified in the usual manner.

In addition, the intermediate stage



Always use the manufacturer's service notes

quencies above 500 kilocycles (wavelengths above 600 meters). At higher frequencies (lower wavelengths), many problems due to the difficulty of controlling the high frequencies are encountered. Capacity coupling and feed back are more troublesome. Vacuum tubes cause problems due to the relatively high inter-electrode capacities. The super-heterodyne circuit was

transformers are usually made "band pass," so that they will pass the required band of audio frequencies, eliminating all others. This gives the receiver high selectivity. It is the high amplification and the inherent selectivity due to tuned intermediate frequency couplers that have caused the super-heterodyne circuit to become very popular.

There are several important points to be watched in the servicing of super-heterodynes. To begin with, the pick-up of a properly adjusted receiver is so great that excessive trouble from outside noises may be encountered. Usually a careful study of the antenna system and reference to the service notes of the manufacturer will enable the service man to reduce or eliminate objectionable noises due to local electrical interference. No unusual trouble should be encountered if this is the case.

Usual Tests

When a set is found to be entirely inoperative, the usual tests should be applied. The tubes should be carefully tested; the plate, grid, cathode, or filament voltages should be read to see that they are normal. Check the loudspeaker unit, and so on, making sure that all connections are clean and tight. If reproduction is still unsatisfactory after the set has been restored to operating conditions, it will be necessary to make one or more of the following adjustments.

Distortion or oscillation may be caused by a number of things. A defective tube may sometimes cause a stage to oscillate. Open by-pass condensers will allow enough high frequency to be

fed back to cause oscillation. By consulting the service notes you will be given a definite plan of procedure on

tors on the market at the present time, should the service man wish to buy one.

It may be found necessary to adjust the radio frequency line-up condensers or the oscillator trimming condensers. To do this, use the high frequency oscillator, taking great care that it is accurately calibrated. The service notes should again be consulted to determine the proper procedure and the location of the adjusting condensers.

Another important adjustment is the tuning of the intermediate stage transformers. Again it will be necessary to use an oscillator and the manufacturer's service notes. Read the instructions very carefully before proceeding.

The Final Adjustment

The final adjustment for distorted reproduction (assuming, of course, that the loudspeaker is working properly) is the alignment of the gang tuning condensers, including those for the local oscillator and the radio frequency stages. The entire scale should be checked using a high frequency oscillator, and following the procedure outlined in the service notes.

The importance of using the manufacturer's service notes is again emphasized.

Satisfactory work can not be done until the service man is thoroughly familiar with the construction and location of adjustments on the various types of receivers. Unless properly adjusted, the super-heterodyne will not deliver its maximum in sensitivity and selectivity. Properly adjusted, it will give the kind of reception it is noted for.

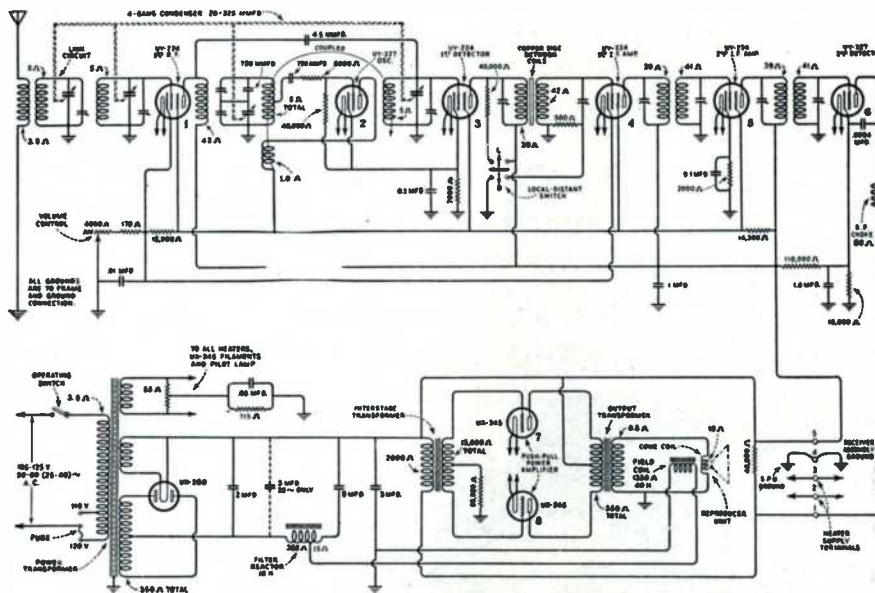

Super-heterodyne circuit employed in RCA Radiolas 80, 82, and 86

how to correct these faults.

In making these adjustments, it will be necessary to use a high frequency oscillator that will give a relatively low frequency signal (usually about 130, 175, or 180 kilocycles). Very often, the manufacturer's service notes contain data on the construction of such an oscillator. The high frequency oscillator described in the September and

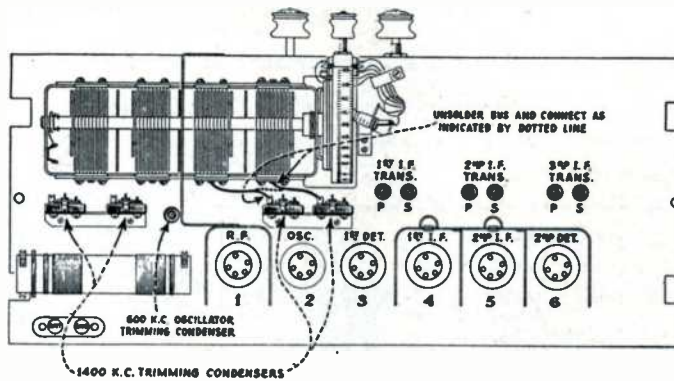

Location of trimming condensers in RCA Radiola super-heterodynes

October issues of Good News is not satisfactory for this work unless the inductance is changed, so that it will tune down to the required frequencies. While this change can be made, it is not desirable because difficulty will be encountered in accurately calibrating at these frequencies. There are several satisfactory makes of oscilla-

The Road to Profit

*Without Adequate Merchandising Turnover, Retailing
Success is Next to Impossible*

By H. R. Rusk

Sales Promotion Dept., RCA Radiotron Co., Inc.

AFTER a twenty year wait," reports the *New York Evening Post*, "Martin Chiatovich has found a buyer for his automobile."

A museum, the Smithsonian Institute of Washington, paid \$1500 for it. Mr. Chiatovich held out for his price and he got it. Brave man, Chiatovich, asking for a price and sticking to it. But let's see what it cost him to "get his price."

Figuring that he wanted \$1500 for it originally, if Mr. Chiatovich had sold his car for \$1000 and banked the money at 4½ per cent interest compounded quarterly he would have today approximately \$2500.



One Key to Success

Turnover is one key to successful retailing. Without turnover, you cannot possibly hope to make a good profit.

The dealer who holds any item of merchandise more than six months—just to get his price—is as foolish as Mr. Chiatovich. Now is the time to rid your stock of slow-moving items if good profits are to be made in your business during 1931.

The principle of turnover is simple. In the first place, a store does not make a profit until it makes a sale.

Secondly, the faster these sales are made, the faster profits come in. This is just another way of saying that the more rapid the turnover of merchandise, the more rapidly profits are

made. Quality merchandise which enjoys universal acceptance and continued demand, has a greater ultimate

yield than inferior merchandise, or even unadvertised quality merchandise, offering a larger theoretical gross profit. No matter how large the discount on radio tubes of unknown quality, there can be no profit if they are not sold.

causes of slow-selling goods. Radio tubes, as well as other products, must be sold before a fair profit can be maintained. In the past, many radio dealers considered the radio tube as an article to be stocked merely for the convenience of their set customers. The inevitable result was large, unbalanced stocks of tubes, of many different brands—which only confused the prospective purchasers. They bought reluctantly, without faith in the superiority of one brand over another. Needless to say, the brands which did sell quickly could not make up for the losses on the slow-moving stock, and the result was plainly reflected in the dealer's profits.

An accumulated stock of slow-moving merchandise presents a very

complex problem to the merchant. Aside from the invested capital, which is yielding no return, he is faced with the possibility of the deterioration of his merchandise. Of course, the electrical characteristics of the radio tubes do not generally vary with age, but the carton becomes shop-worn and loses much of its original attractiveness.

All too often, the prospective buyer, ignorant of the technical values of a radio tube, judges quality by the appearance of the wrapper. A well-kept display of radio tubes is of great value as a sales stimulus. In

Type	List	Dealer's Cost	Type of Dealer					
			Large		Average		Small	
			Quantity	Net	Quantity	Net	Quantity	Net
UX-226	\$ 1.75	\$1.05	50	\$52.50	12	\$12.60	6	\$ 6.30
UY-227	2.20	1.32	75	99.00	20	26.40	12	15.84
UX-245	2.00	1.20	75	90.00	20	24.00	12	14.40
UX-201A	1.25	.75	0	37.50	25	18.75	10	7.50
UY-224	3.30	1.98	75	148.50	20	39.60	12	23.76
UX-280	1.90	1.14	40	45.60	15	17.10	8	9.12
UX-171A	2.25	1.35	12	16.20	12	16.20		
UX-199	2.50	1.50	12	18.00	12	18.00		
UX-112A	2.25	1.35	12	16.20	12	16.20		
UV-199	2.75	1.65	12	19.80	6	9.90		
UX-281	7.25	4.35	6	26.10	3	13.05		
UX-222	4.50	2.70	6	16.20				
UX-250	11.00	6.60	6	39.60				
UX-240	3.00	1.80	4	7.20				
Total.....				\$632.40		\$211.80		\$76.92

Why Goods Move Slowly

Consumer demand alone, however, cannot insure a satisfactory turnover on merchandise. Poor salesmanship, poor advertising, and poor display are

addition, it has a good psychological effect on your sales force. Certainly, the feeling that, "Here is something new," is more likely to encourage enthusiasm in the clerk than, "Here is something we are trying to get rid of."

Progress in the radio industry is rapid. Constant new developments greatly reduce the values of old stocks, while revolutionary changes may render them entirely obsolete. To carry a large stock of slow-moving tubes is obviously a dangerous policy.

A Lesson in Retailing

One merchandise manager said that the most logical way to reduce slow-selling merchandise was not to buy it. Suppose a dealer wishes to invest \$200 in radio tubes. His first problem is to decide which brands he will stock. RCA Radiotrons have a discount of 40 per cent off list; other brands may offer "50 and 5" per cent or more. The old, familiar temptation of the longer discount asserts itself, and the dealer invests \$100 in each brand. But he finds that, during the year, it is necessary to order RCA Radiotrons ten times to supply the demand, while the other brand requires only one or two re-orders with a lot of pushing. This dealer should not have to have

counts make up profits for the slow movers." It must be remembered that some of these "slow movers" may never be sold, and it is these "stickers" in the stock which are pulling down the profits on the tubes that are sold. You may buy a gross of tubes and sell eleven dozen. These eleven dozen bring you enough money to pay for all the tubes and the overhead cost of selling them. But where is the net profit? It is in the one dozen you do not sell. Furthermore, as long as the unsold tubes remain in stock, they are accumulating more than their normal share of carrying charges. The best method is to stick to one fast moving brand, and this applies whether that brand is RCA Radiotrons or not.

Don't Overdo It

There is, of course, a point beyond which it is impossible to reduce your stock and still make a profit. In their zeal to promote turnover, many mer-

It should be remembered that every set owner is a prospect for an entire new set of RCA Radiotrons. A call for any one type of tube will usually indicate that the other tubes in the set are also old and worn out.

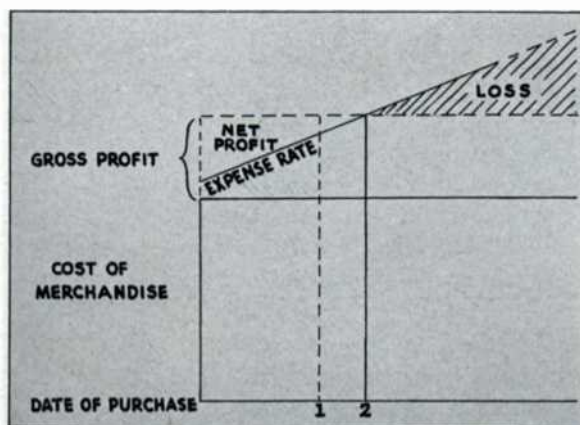

ADAPTED FROM "DOMESTIC COMMERCE"

Figure 1 indicates end of period normally required for sale of merchandise at anticipated profit. Figure 2 shows how accumulated carrying charges wipe out profit when turnover is not maintained

A shortage in any of the types will result in the loss of a complete renewal sale. We may conclude, therefore, that the only sound method of increasing turnover on RCA Radiotrons is to maintain a normal inventory to meet your customers' requirements; then exert every effort to increase the volume of your sales.

The Modern Spirit

This is the spirit with which progressive dealers are conducting their radio tube business today. They are concentrating on one brand, RCA Radiotrons, for increased sales. Why? Because RCA Radiotrons are backed by the most extensive advertising campaign in the history of the radio tube industry. Through magazines, newspapers, and radio, the message of RCA Radiotron superiority and the necessity for replacing old, worn-out tubes with new RCA Radiotrons is being put before millions of consumers. And, in addition to all that, the RCA Radiotron Company is—through the Headliner Plan—giving valuable help to its dealers in order to assist them in taking advantage of this fast growing demand. The combination is one which cannot be beaten. It spells certain prosperity for 1931.



the advantages of turnover explained to him further.

On the other hand, we may hear it argued that, "Some brands move faster than others, but additional dis-

chants do not buy enough. This is an example of carrying a perfectly sound idea too far, rather than an indication of any inherent fallacy in the turnover principle.

RADIO TONICS

By G. Gerard Clark and T. A. Joloff

Sales Promotion Department, RCA Radiotron Company, Inc.

IN THIS month's windows we have attempted to visualize, to dramatize, the vastly important function of the radio tube in the operation of a radio set, and to show how the presence of one bad tube is reflected in reception.

It is all very well to tell people to renew their tubes and to list the reasons why they should, but most of them will fail to grasp the idea, to understand the effect, unless that idea is presented to them in visual form.

That is why, in all RCA Radiotron magazine and newspaper advertising, the "Renew Your Tubes" copy is invariably accompanied by a vivid illustration. This illustration—two radio tubes side by side, one (an RCA Radiotron) containing a clear-cut musical note and the other (labelled "worn-out tube") containing a wavering, indistinct note—is very simple; yet the comparison is inescapable.

Every dealer can add his bit to this education of the public to the renewal idea—can, in fact, lay the strongest kind of a claim to the renewal business in his territory—by using his windows to drive home the "Renew Your Tubes" message.

Two suggested windows, with instructions, are presented herewith.

Window Number One

1. Since this window is built around a radio set, the latter should be placed in the center, against the back board. A Super Selling Fool on top, holding the display card which reads—"Equipped with RCA Radiotrons," is an effective touch.

2. Arrange RCA Radiotron cartons in semi-circular fashion around the set to resemble the walls of a fort. The exact pattern will, of course, depend upon the size and shape of the window space.

3. A touch of realism is obtained with a toy cannon at each corner. Cannons such as these can be pur-

chased cheaply at any department store.

4. As we place Super Selling Fools behind the ramparts, the scene begins to take on action. In our window

GOOD NEWS Posters Available

A small quantity of unmounted, poster-size reproductions of the GOOD NEWS covers for April and September, 1930, have been placed in the RCA Radiotron District Warehouses. The posters are the same as those used in the WD-1 and WD-2 displays, except that they are not mounted on cardboard and contain no advertising matter whatsoever. Colorful and attractive, they are well suited for framing or other decorative purposes.

Headliner and Star Dealers may obtain copies of these, without cost, by writing to their nearest Warehouse. Order by number—WDS-1 or WDS-2.

each of the guns is manned by a Super Selling Fool.

5. The enemies—"Weak Signals" "Hum," "Distortion," and "Static"—represented by lettered placards, are next placed in position just inside the glass. The cards in this window are three inches high and fifteen inches long. They are kept upright by empty cartons placed behind them.

6. Attach a white crepe paper streamer to each of the "enemy" cards and carry it to one of the Super Selling Fools standing in front of the set. The other arms of this pair are used to support the placard reading "Fortify Your Set Against . . ."

7. The two side cards in the rear, lettered as shown, are supported by Super Selling Fools on blocks of empty cartons.

8. No fort is complete without

flags. Our RCA Radiotron pennants to the right and left, are simply cut from the red signature strip that appears at the bottom of our magazine ads. The flagstaves are white cardboard, stuck in the top carton of a ten-carton pyramid.

9. Place several RCA Radiotrons on top of the wall of the fort.

Window Number Two

1. In this window, the back of the radio set is turned toward the glass to give a clear view of one or more tubes in position.

2. The important feature is the streak of lightning, which is suspended by a fine wire attached to the center. One end should touch the upper corner of the window and the other a tube in the radio set. The "flash" is made of composition board covered with silver paper or foil. Materials may be purchased at any hardware store at little cost. In this window, which is quite large, the "flash" is 80 inches long.

3. Triangular units made of cartons pinned together and placed on either side, as shown, make an attractive setting for the cabinet. An RCA Radiotron is placed on each "step."

4. Place cartons in the foreground, as shown.

5. Construct the simple but effective circular center piece of seven cartons and an RCA Radiotron.

6. Put side cards, lettered as in the illustration, in place. These are supported from behind by cartons, as well as being framed by rows of cartons below and on either side of them.

7. A humorous, yet none the less effective, touch is added by having a Super Selling Fool peering from above at the defective tube.

Note: Lettering on all cards in both windows is black, except those letters which appear in the photograph to be of a lighter tint. These are red.

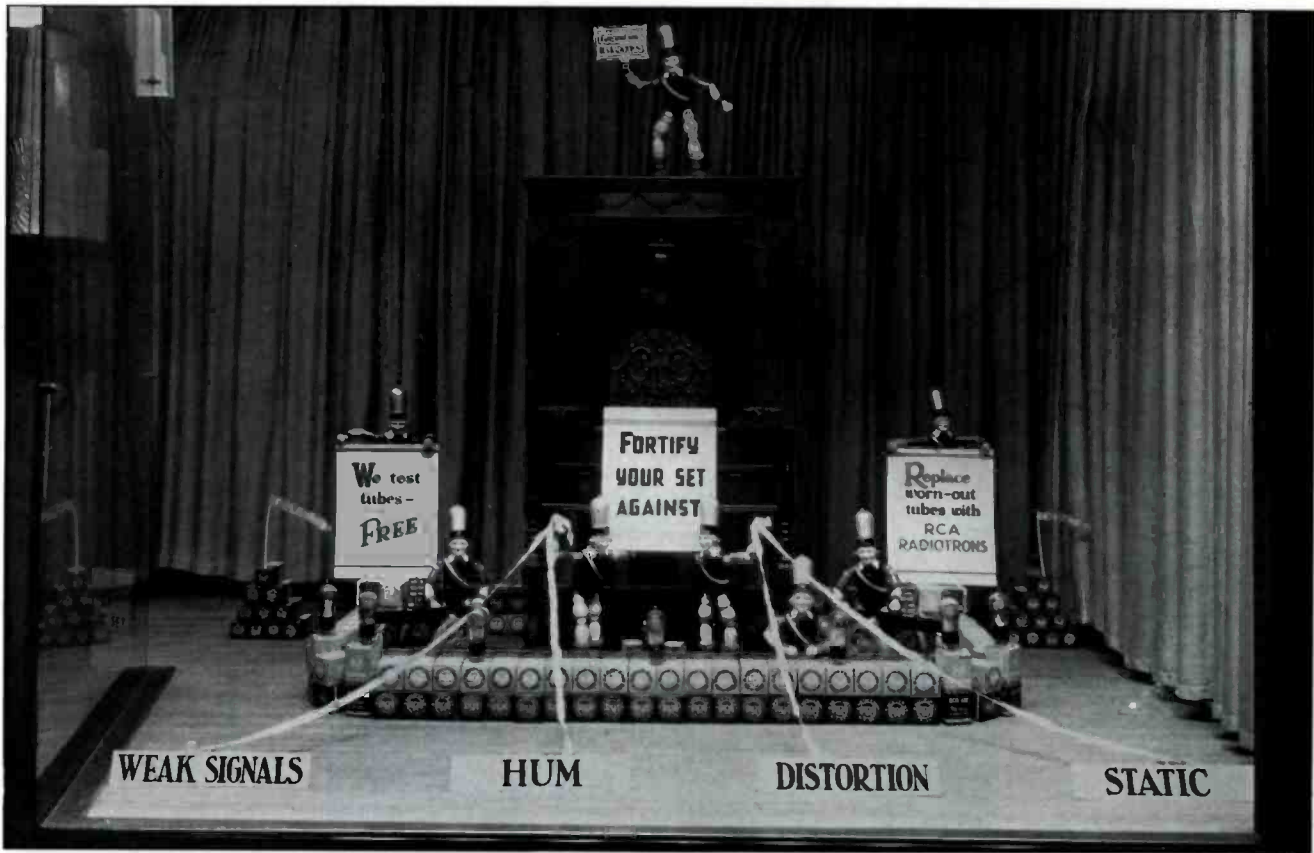

1. An attention-commanding window that carries a very concrete message



2. This display dramatizes the fact that new tubes put new life in a radio set

Radio Tube Characteristics—

The Yardsticks of Tube Performance

By L. G. Lessig

Commercial Engineering Dept., RCA Radiotron Co., Inc.

THE progress of civilization has changed the "Jack of All Trades" to a "Master of One." The radio tube is an outstanding example of this change. It is a specialist in its trade. The job for which it is best fitted depends on its grid, plate, and screen (if any) voltages, the distance between electrodes and the area of each, and many other factors.

It has been shown how filament or cathode temperature affects plate current and how, under ordinary conditions, the cathode is operated "saturated"—that is, at temperatures beyond which there is little benefit from increase in electron emission. The filament voltage for any individual tube should remain fixed. The plate current, however, still depends upon two variable quantities, the grid and plate voltages. In a screen grid tube the screen voltage must also be considered. The manner in which these variables affect the plate current determines the tube's characteristics, which in turn identify its functions.

Amplification Factor

The ratio between the plate voltage change necessary to produce a certain plate current change and the grid voltage change required to produce the same change in plate current is known as the *amplification factor*. It may be expressed thus:

$$\text{amplification factor} = \frac{\text{plate voltage change to produce a given plate current change}}{\text{grid voltage change to produce the same plate current change}}$$

or

$$\mu = \frac{dE_p}{dE_g}$$

(d in an equation is variable indicating an extremely small change.)

If, for example, the amplification



Testing RCA Radiotrons for amplification factor, plate resistance and other characteristics

factor of a tube is 6, adding 30 volts to the plate will increase the plate current a certain amount. The same increase, on the other hand, can be effected by adding only 5 volts (positive) to the grid. Conversely, higher negative grid bias voltage will reduce plate current and allow greater plate voltages, within limits. In other words, any voltage placed on the grid of such a tube has the same effect as a voltage in the plate circuit multiplied—or amplified—by the amplification factor of the tube.

The amplification factor for a given tube generally does not vary much under the conditions for which the tube is ordinarily used. It is controlled largely by the mechanical construction of the tube. Amplification factor increases with increasing distance between grid and plate.

Plate Resistance

When a plate current flows between the plate and the filament of a radio

tube, a resistance is offered to the flow. The radio vacuum tube operates with pulsating and not constant values of grid voltage, plate voltage, or plate current. Such a pulsating current is considered to be a combination of direct current and alternating current. The resistance of the tube to alternating current differs from the resistance to direct current. We will consider here only the resistance offered to the flow of alternating current. It is known as plate impedance, or plate resistance. It is the ratio of the change in plate voltage to the change in plate cur-

rent, and may be expressed in the following relation:

$$\text{Plate resistance} = \frac{\text{change in plate voltage}}{\text{change in plate current}}$$

or

$$r_p = \frac{dE_p}{dI_p}$$

The plate resistance is a measure of the effect of the plate voltage alone upon the plate current. At low values of plate current in three-electrode tubes, the plate resistance is relatively high. As the plate voltage is raised, the plate resistance first decreases rapidly, and then more slowly, as the normal operating voltage is reached. If the applied voltage is very high, the plate resistance may again increase. This critical value indicates that the emission saturation point is being reached; that is, practically the full emission current is flowing. In general, the case is different with screen grid tubes, since other factors affect the plate resistance.

If the filament emission at high plate voltages limits the plate current, the plate resistance will increase. This decreases the efficiency of a vacuum tube as an amplifier. The available emission of a UX-199 is approximately three times the value of the plate current (2.5 milliamperes) when the negative grid voltage is 4.5 volts and the plate voltage is 90 volts. With no grid bias, the plate current becomes about 5.75 milliamperes, which is close to the value of the emission current. It is at once obvious that a grid bias should be used with all tubes at high plate voltages.

Plate resistance not only depends upon operating voltages, but also upon the dimension and shape of the elements of the tube. The best value of plate resistance to be incorporated as a design factor of a tube depends upon the service for which the tube is intended and the power which is available to supply the filament and plate currents.

Mutual Conductance

Both the plate resistance and the amplification factor of a vacuum tube affect its performance as an amplifier. When comparing the merits of tubes, it is convenient to use a term called *mutual conductance*, which takes both of these factors into consideration. Mutual conductance is the ratio of amplification factor to the plate resistance. It is expressed as follows:

$$\text{Mutual Conductance} = \frac{\text{Amplification Factor}}{\text{Plate Resistance}}$$

or $G_m = \frac{\mu}{r_p}$ which becomes $\frac{dI_p}{dE_g}$

Thus, mutual conductance may be expressed as the ratio of a small change in plate current to a change in grid voltage to produce this change in plate current.

In comparing tubes of the same type which are to be used for the same purpose, the mutual conductance is the best measure of efficiency—but it must not be worked too hard. The unit of mutual conductance is the micromho.

Thus, the UX-112-A has an average mutual conductance of 1700 micromhos at a plate voltage of 180 volts, and the UX-171-A has mutual conductance of

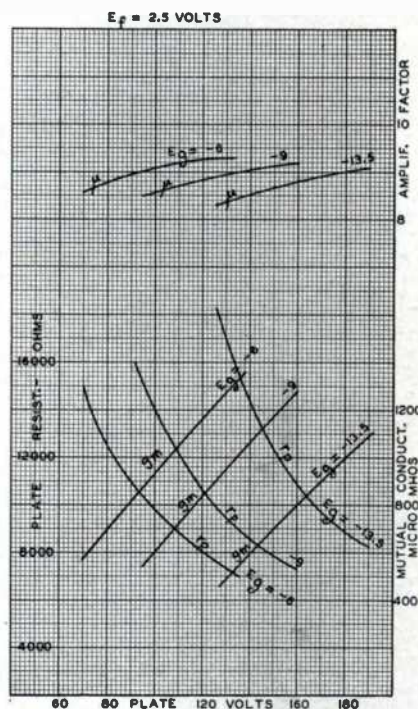

Average characteristics of a typical three-electrode radio tube, the UY-227. The curves represent plate resistance, mutual conductance, and amplification factor. It can be seen that a variation in any one will cause variation in the others

about 1620 micromhos at the same plate voltage. The UX-171-A can supply approximately three times more

radio or an audio-frequency amplifier. A tube with excessively high mutual conductance will cause a radio-frequency and audio-frequency amplifier not designed for such tubes to oscillate. This is often the effect when the battery type Radiotrons RCA-230, RCA-231, and RCA-232 are substituted for types UX-199, UX-120 and UX-222 in receivers designed for the latter.

Proper Care of Tubes

Filaments and heaters of radio tubes are operated at definite temperatures. These temperatures depend upon the voltages applied to the filaments and heaters. Less than rated voltages result in loss of temperature and reduced emission. More than the rated voltage causes excessive temperature, which may rapidly deteriorate the filament or cathode. It can thus be seen that filaments and cathodes should always be operated at their rated voltages.

Likewise, it is essential that plate current be kept at the rated value. Some receiver manufacturers in the past have used general purpose tubes without proper grid bias voltage, with the result that the plate current was excessively high and tube performance was impaired.

Construction

A radio tube is not merely an assembly of glass, wire, and insulating material, which can be thrown together in a hurried, haphazard manner. Rather it may be likened to a fine, many-jewelled watch, which represents the very best that money can buy. It is, in reality, a small electrical machine which may be put to many intricate uses. For this reason alone,

only the very finest materials and most careful workmanship can be used in its construction.

In a future issue, these pages will be devoted to the manufacture of RCA Radiotrons.

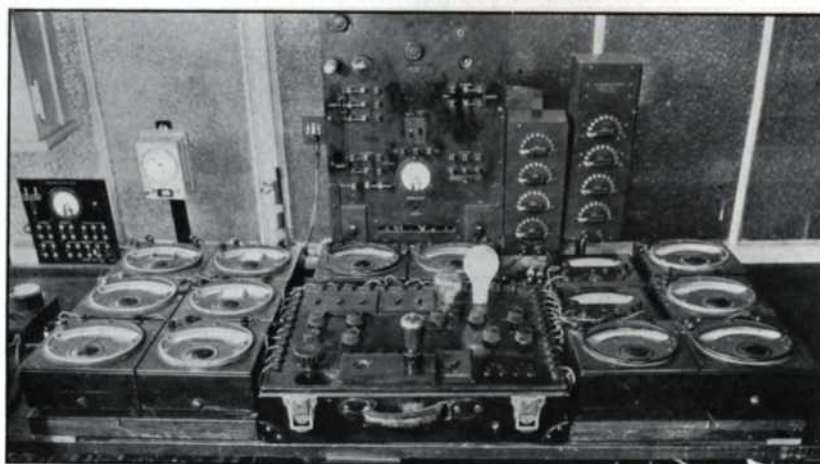

Test equipment used by RCA Radiotron Service Stations

undistorted output than the UX-112-A when input voltage is available and the load is properly adjusted. The tube with the higher mutual conductance and high amplification factor will give greater signal strength in either a

A Little Imagination + a Little



The Henry G. Trent Furniture Company, Knoxville, Tennessee, gives tone to a large window by this ingenious arrangement of RCA Radiotron cartons

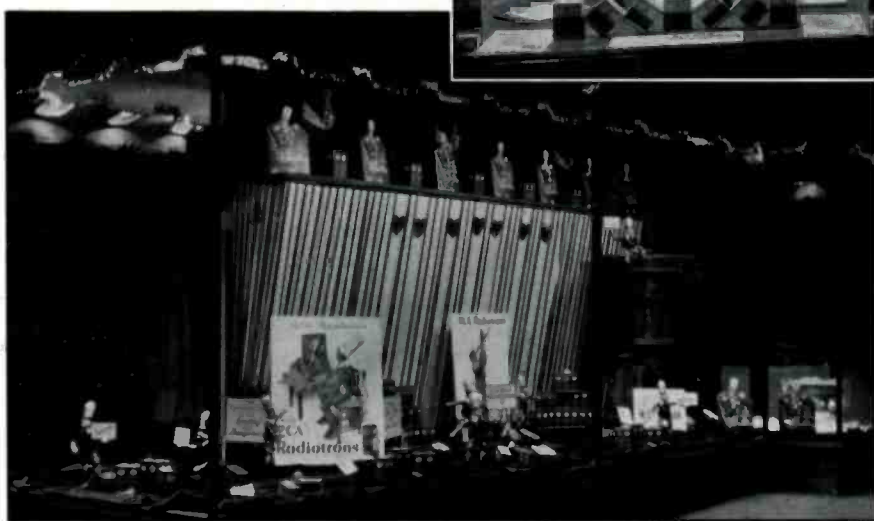

A handsome Valentine Day window in Easton, Pa., conceived and installed by the Electric League of Easton and Phillipsburg



The Thanksgiving window of the Radio Salon, Inc., Brooklyn, N. Y.—three of whose highly effective displays are reproduced on these pages



Another Radio Salon window, giving evidence of an unusual degree of imagination and inventiveness

Effort = Windows That Sell



Demonstrating that originality does not necessarily imply intricacy. A simple, yet interesting, window of the J. R. Reed Music Company, Austin, Texas



Sensing the Super Selling Fool's flair for comic delineation, the Iowa-Nebraska Power and Light Company's decorator has given us a hula-hula dance



A realistic football game that drew attention to Philadelphia Victor Distributors' window in Harrisburg, Pa. "Result—A Perfect Match"

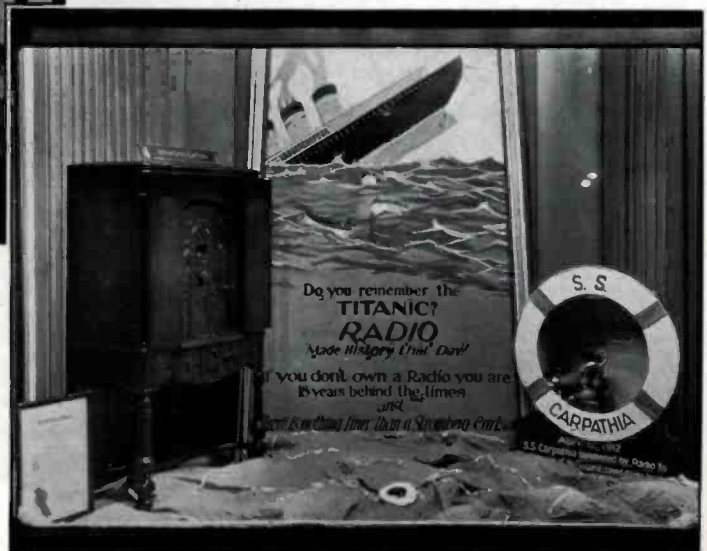

Radio Salon, Inc., draws from history to dramatize a sales point. Note Selling Fool as radio operator in insert

Headliner Material + + +

NOTE—A full description of most of this material, with illustrations, is contained in January GOOD NEWS.

Displays

DECALCOMANIA—Silver tube, green lightning, red slogan. Size, 10" by 12 1/2". Free. Order from Warehouse.

FOOTLIGHT SIGN—A combination floodlight and sign made of bronze. Lettering "RCA Radiotrons" silhouetted on glass. Size, 10" high, 22" long, and 5" deep. Price, \$5 each, including 10-foot cord and plug. Order from Harrison.

WINDOW DISPLAY No. WD-1—

"For Better Radio Reception" features boy putting up aerial. Lithographed in full color. Size 24" by 31 1/2", for center panel. Two side cards 11" by 14", "Bring in your tubes and have them tested free" and "RCA Radiotrons plus our service insure satisfaction." Sixty dummy cartons included. No charge. Order from Warehouse.

WINDOW DISPLAY No. WD-2—

"Life-like Reproduction." Boy masquerading as Selling Fool. Lithographed in full color.

Size, 24" by 31 1/2" for center panel. Two side cards 14" by 9 3/4" with folding flanges. Flange at top folds back and holds three tubes. Free. Order from Warehouse.

SPRING DISPLAY—An unusual and effective display that is bound to appeal to anyone even remotely interested in broadcasting. Now in production. Ready for distribution about May 1. Free.

FALL DISPLAY—Dramatizes reasons set owners should change their tubes once a year. In production. No charge.

No. 4 DISPLAY—RCA Radiotron man cutout is used as carton holder. Lithographed in six colors. 15" by 8 3/8". No charge. Order from Warehouse.

* Indicates material available to Headliner Star Dealers only.

MODERNISTIC DISPLAY—Hand made, imported display, four colors, 12 1/2" wide, 19 3/4" high, 3 1/4" deep. Silver tube. Red and green cutout lettering. Red lightning. Glossy, washable finish. Price, \$1.50. Order from Warehouse.

SUPER SELLING FOOL—Red feet, yellow legs, red and yellow arms, black body, natural tinted features, hat in shape of silver tube, black base. Made from molded wood turnings. Flexible. Held together by elastics and springs. Slotted feet and hands to hold cards. Ring in hat for suspension. 15" high.

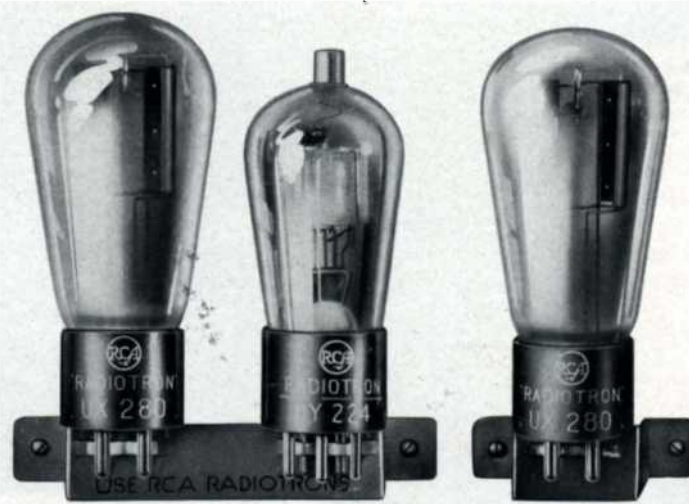

Screwed inside every set sold or serviced, the spare tube clip will invalidate the chief argument against buying "extra" tubes—"no place to put them"

\$5 for four, including 14 two-color display cards. Order from Warehouse.

TRANSFER STRIP—Lithographed red and black, easily applied. Slogan: "RCA Radiotrons—The Heart of Your Radio." Carton and tube reproduction. 10 3/4" by 1 7/8". Free. Order from Warehouse.

GIANT TUBE—Tri-dimensional papier mâché model of RCA Radiotron UY-224. Black base, silver tube. 24" high. Price, \$4. Order from Warehouse.

Utility Material

ADDRESS LABELS—3 1/2" by 5 3/4", lithographed in red and black. Supplied un gummed, with your imprint. No charge. Order from Harrison.

SET PRICE SIGNS—Made of pol-

ished celluloid and lithographed in two colors. Size, 3" by 4". Slot in back for the insertion of price card. Price, 10 for \$1. Order from Warehouse.

SET SIGN—Polished celluloid. Red and black. Copy—"This set is equipped with RCA Radiotrons." Size, 5" by 1 3/4". Price, 12 for \$1. Order from Warehouse.

TAPE MACHINE—Made of cast iron and steel. 10" by 2 1/2" by 4 1/2". \$4.25 each, including 10 rolls of tape. Order from Warehouse.

TAPE ROLL—Two colors with the slogan: "RCA Radiotrons—The Heart

of Your Radio." Five hundred feet, one inch wide. Price, 10 for \$2, unimprinted. Order from Warehouse.

***CLOTH BANNER**—Weatherproof, durable drill cloth; size 48" by 29"; lithographed in five colors; metal grommet in each corner for attaching purposes. Packed and shipped individually. Used on your truck, inside your store, and on the window. No charge. Order from Warehouse.

SPARE TUBE CLIPS—Polished nickel steel. Hold

tubes with either four or five prongs. 1 1/2" clearance for tubes. Length over all, single tube clip, 3"; 2-tube clip, 5". Price, including necessary wood screws, single tube clip, \$1.50 per 100; 2-tube clip, \$2 per 100. Order from Warehouse.

Sales Promotion Material

REMEMBRANCE ADVERTISING—Key Container, Note Books, Shopping List, Erasers, Book Matches, Pencils, Celluloid Tape Measure. For descriptions and prices see page 45, January GOOD NEWS. All should be ordered from Harrison.

CATALOG AND PRICE LIST—Description of each RCA Radiotron, list and net prices, standard package quantities and RCA Radiotron char-

acteristics chart. No charge. Order from Warehouse. One per dealer.

BUSINESS BUILDING SALES LETTERS—Twelve suggested letters to build tube renewal business and three reply cards. No charge. Warehouse.

BLOTTERS—Featuring popular Good News covers. Four designs in four colors. Size $3\frac{1}{4}$ " by 6". Price, 40 cents per 100 with your imprint; minimum order 300. Harrison.

BROADCAST DIRECTORIES—American, Canadian, Mexican, and U. S. possession stations; pictures and biographies of 21 leading announcers. Studio slang, messages to customers, and catalog of RCA Radiotrons. Price, \$2.50 per 100; in lots of 1000, \$2.25 per 100; in lots of 2500 or more, \$2 per 100. These prices are with or without imprint. Harrison.

BROADCAST DIRECTORY POST CARD—Invites customers to call for copy of Directory, explaining its advantages. Printed black and red on manila stock. Unimprinted, no charge. Imprinted, 40 cents per 100. Minimum order, 100. Stamped, 1 cent per card extra. Order from Harrison by number, P-15.

***POST CARDS**—Set of four. Red and black on manila post card stock. Unimprinted, no charge; maximum order, 500 sets. Imprinted, 40 cents per 100; minimum order, 300, not less than 100 of any design. Stamped, 1 cent per

card extra. Order from Harrison by number, P-10, P-11, P-12, and P-13.

NEW PRICE LIST—Attractive four-page folder, containing complete list of prices on RCA Radiotrons and two interesting messages to consumers. Used as envelope enclosures, package inserts, etc. Size, $3\frac{9}{16}$ " by $6\frac{3}{16}$ ". Un-



Mailed out to prospective customers periodically, these cards are bound to prove a potent stimulus to the renewal business

imprinted, no charge. Imprinted, 40 cents per 100; minimum order, 300. Order unimprinted from Warehouse, imprinted from Harrison.

PRICE REFERENCE CARD— $4\frac{1}{4}$ " by $8\frac{1}{2}$ "; for reference only. No charge. One per dealer. Warehouse.

LANTERN SLIDES—Six hand-colored, with three-line imprint. No charge. For local theatre advertising. Order from Harrison.

SET NAMEPLATE—Brass, gold lettering on black background. Size 4" by 2". Fastened by gummed back or small brads. Space to write date tubes should be renewed. Your imprint at bottom, black on gold; 3 lines or less, no more than 28 letters to a line. Imprinted, \$3 per 100. Harrison.

TECHNICAL BULLETINS—Technical information on all RCA Radiotrons. Free. Address requests to Commercial Engineering Dept., Harrison.

RCA RADIOTRON REFERENCE BOOK—Red leather cover, name in gold letters. Size, $2\frac{1}{8}$ " by $5\frac{3}{4}$ ". Sixty pages radio definitions, symbols, engineering data, merchandising tables, tube characteristics lists, service rules, etc. One already sent to each Headliner Dealer and 2 to each Headliner Star Dealer. Additional copies, \$1 each. Warehouse.

SOCKET LAYOUT GUIDE—For all standard sets. Shows what tubes each model uses. Engineering data, etc. One already sent to each Headliner and Headliner Star Dealer. Additional copies 50 cents each. Warehouse.

NEWSPAPER MATS—For insertion in local newspapers. Tie in with national RCA Radiotron advertising. Free. Warehouse.

***SERVICE DEPARTMENT PLAN**—Complete, for merchandising your Service Department. Includes placard for window, post card and folder, all featuring service. Maximum order 500 sets. Warehouse.

***"RENEW YOUR TUBES" BOOKLETS**—Series of six booklets, two colors. Used as envelope or package enclosures. Unimprinted, free; maximum order 500 sets. Imprinted, 40 cents per 100, any quantity. Harrison.

Where and How to Order

[[Print—do not write—imprint instructions. Check or money order must accompany all orders for those sales aids for which there is a charge, unless ordered through your distributor.]]

Eastern District

Order from Sales Promotion Department, RCA Radiotron Company, Inc., Harrison, N. J.

District includes: Connecticut, Delaware, District of Columbia, Maine, Massachusetts, New Jersey, New Hampshire, Rhode Island, Vermont, Virginia, Maryland—except Allegany and Garrett Counties; New York—except Niagara, Orleans, Monroe, Genesee, Erie, Wyoming, Livingston, Chautauqua, Cattaraugus, and Allegany Counties; Pennsylvania—eastern part bounded by Tioga, Lycoming, Union, Mifflin, Juniata, and Franklin Counties.

Lake Erie District

Order from Mr. L. E. Mitchell, RCA Radiotron Company, Inc., 1133 East 152nd Street, Cleveland, Ohio.

District includes: Ohio, West Virginia, Kentucky—east of and including Hancock,

Butler, Ohio, and Logan Counties; Maryland—Garrett and Allegany Counties only; Michigan—except those counties adjacent to Wisconsin; New York—in counties mentioned above as not included in the Eastern District; Pennsylvania—counties bounded by western county boundaries mentioned in the Eastern District.

Southern District

Order from Mr. E. E. Jordan, RCA Radiotron Company, Inc., 498 Spring Street, N. W., Atlanta, Ga.

District includes: Alabama, Florida, Georgia, Mississippi, North Carolina, South Carolina, Tennessee, Louisiana—east of the Mississippi.

Central District

Order from Mr. W. J. Flannelly, RCA Radiotron Company, Inc., 589 E. Illinois Street, Chicago, Ill.

District includes: Colorado, Illinois, Indiana, Iowa, Kansas, Minnesota, Missouri, Nebraska, North Dakota, South Dakota, Wisconsin, Michigan—part bounded by Lake Michigan on South and Lake Superior on North; Kentucky—southwestern part.

Southwestern District

Order from Mr. W. A. Magevney, RCA Radiotron Co., Inc., 2200 Griffin Street, Dallas, Texas.

District includes: Arkansas, New Mexico, Oklahoma, Texas, Louisiana—west of the Mississippi.

Pacific District

Order from Mr. H. G. Cunningham, RCA Radiotron Company, Inc., 325 Ninth Street, San Francisco, California.

District includes: Arizona, California, Idaho, Montana, Nevada, Oregon, Utah, Washington, Wyoming.



Why Make Set Selling Harder?

RCA Radiotrons help to sell even the finest receiver—
You don't have to apologize or explain! » » » » » » » » » »



Every Wed. and Sat. night the Radiotron Varieties, through its popular announcer John S. Young, sends this message to set owners from Coast to Coast:

"Why gamble with your radio enjoyment? When you buy one of the marvelous new sets now being offered, be sure to look inside the cabinet and make certain the set is equipped with RCA Radiotrons. RCA Radiotrons cost no more than ordinary tubes."

TODAY radio purchasers expect value for their money—and are making certain that they get it.

Wise radio set buyers are looking inside the cabinet to make certain that the tubes are Radiotrons. When they find unknown tubes an element of doubt enters their minds, throwing up a sales barrier. This barrier not only makes set selling harder, but results in lost sales and profits.

At a time when most tube manufacturers are curtailing advertising expenses, the RCA Radiotron Company is giving its dealers increased sales support. Twice-weekly broadcasting programs, a weekly schedule in national magazines, newspaper advertising twice a week—these and many more activities are increasing the already existing public demand for Radiotrons—the fastest selling radio tubes.

Give your customers what they want. Insist that your distributor deliver your sets with Radiotrons.



RCA RADIOTRON COMPANY, INC. » » » HARRISON, N. J.

A Radio Corporation of America Subsidiary

RCA Radiotrons

THE HEART OF YOUR RADIO

Printed by
 THE MAQUA COMPANY
 Schenectady, N. Y.