

May-June, 1969 • Volume 12/No. 5-6

Automatic Chroma Control

Essentially, the automatic chroma-control (ACC) circuit associated with the chroma-bandpass amplifiers performs about the same function as the automatic gain control (AGC) performs in the receiver IF and RF system. In this latter system, the AGC samples the amplitude of each horizontal-sync pulse and automatically adjusts the gain of the tuner and IF strip to maintain a constant amplitude of sync pulse at the output of the video detector. The AGC system **does not** directly control the amplitude of video, but since sync and video are transmitted with a definite ratio of amplitudes (black level is about 66% of sync-tip level), the AGC circuit **indirectly** controls the video level at the video-detector output.

Superficially, there appears to be no need for ACC, since the AGC circuit controls the video level, and both burst and chrominance information are a part of the composite video. While this is true, a number of factors may make it desirable to automatically control the chrominance level.

In the ACC system, the amplitude of each burst is sampled and the gain of the chroma-bandpass amplifier is automatically adjusted to cause the level of **burst** at the output of the stage under ACC control to remain constant over a wide range of burst amplitudes at the video-detector output. The amplitude of chroma signal for any specific hue and saturation (100% saturated red, for example) always has the same amplitude in relation to burst; therefore, the ACC system **indirectly** controls the chrominance level.

Broadcasting specifications require that the peak-to-peak amplitude of burst be the same as the amplitude of the horizontal-sync pulse measured from blanking pedestal to sync tip. This is shown in Figure 1. However, the tolerance is $\pm 10\%$, making it possible for burst from one station to be 20% less than burst from another station in the same area.

Another factor which may affect the ratio of sync and burst amplitudes is the receiving antenna. A "suck-out" near the burst frequency on one chan-

nel may seriously attenuate the amplitude of burst and chroma in relation to the sync pulse. Of course, if the alignment of the receiver is incorrect, the amplitude of burst may be too high or too low and ACC will help to compensate for this. This **does not** imply that ACC should be relied upon to correct misalignment; it will eliminate the effects of the slight, within-tolerance changes in response which normally exist from one channel to another.

It is worth noting that ACC **will not** correct chroma-level problems which result if the transmitting station does not maintain the proper ratio between burst level and chrominance level. By the same token, AGC will not correct a "washed out" picture which is the result of insufficient video modulation at the transmitter.

Two basic systems of ACC are used in current instruments. Figure 2 shows, in simplified form, the ACC circuit of the CTC 38. In the next issue, a simplified schematic shows the circuit used in the CTC 40.

Referring to Figure 2, the first bandpass amplifier, V701B, amplifies the color burst and chrominance information, but not luminance video (the center frequency of L701 is about 4 MHz), and delivers two outputs, one to the color control and the other to the burst amplifier. It is the function of the burst amplifier, V702, to separate the burst from the

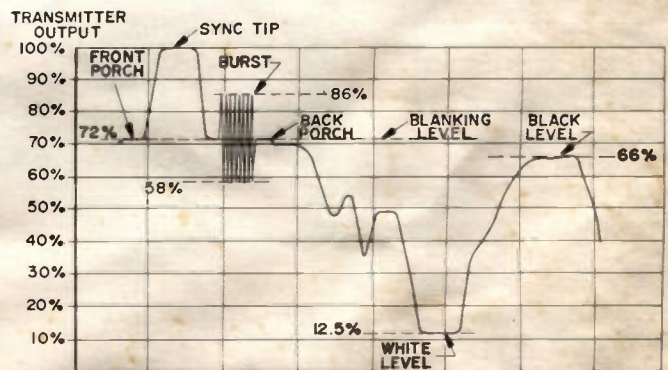

Figure 1 — Amplitude Relationships in Broadcast Signal



chrominance information and, subsequently, to amplify the burst.

The burst amplifier is essentially a coincidence gate—its two inputs must coincide in time or there will be no output. In the absence of signal from V701B, there is but one input to V702, a positive retrace pulse from the horizontal-output transformer. This pulse drives the tube into conduction, producing a voltage drop of about 45 volts across R732, the cathode resistor. Since the time constant of R732 and C725 is more than 40 times the interval between retrace pulses, the voltage on the cathode remains at about 45 volts from one pulse to the next, keeping the tube in cutoff at all times when the pulse is not present.

Since V702 is normally cut off, signals fed to it from V701B can be amplified only if the retrace pulse also is present. Since the color burst from V701B and the retrace pulse from the horizontal output transformer do arrive at the grid of V702 at the same time, they can be amplified by the tube. However, the plate load of V702 is a resonant circuit which is tuned to burst frequency and has very little impedance at the frequency of the retrace pulse. Since gain is roughly proportional to plate-load impedance, the stage amplifies the burst but not the retrace pulse, thereby separating the two. Because of this action, the amplitude of the burst at the output of T701 is **relatively inde-**

pendent of the amplitude of the retrace pulse. It is dependent on the amplitude of the burst pulse from V701B.

The burst energy is fed through Y101 to the grid of V703B, the reference oscillator, locking the oscillator in phase with burst. An increase in burst amplitude increases the oscillator grid drive, causing the grid self-bias to become more negative. Therefore, the voltage on the grid of V703B is a true indication of burst amplitude.

Note that this is similar to the action of the AGC keyer. In the AGC system, the received sync pulse is separated from the other video by the AGC keyer tube, which also is a coincidence gate. The keyer tube amplifies the sync pulse and converts it to a filtered, negative voltage which is proportional to the sync-tip amplitude.

The negative grid voltage of V703B, filtered by C719, controls the collector current of Q702 and, ultimately, the voltage at the junction of R727 and R170. Since Q702 is a common-base amplifier, there is no signal inversion. As the grid voltage of the oscillator, V703B, swings more negative (due to an increase in burst amplitude), the output of Q702 also swings negative, reducing the gain of V701B. This, of course, has the desired effect of maintaining the amplitude of burst at the output of V701B substantially constant, even if there are fairly large changes in the magnitude of the input.

(To be continued)

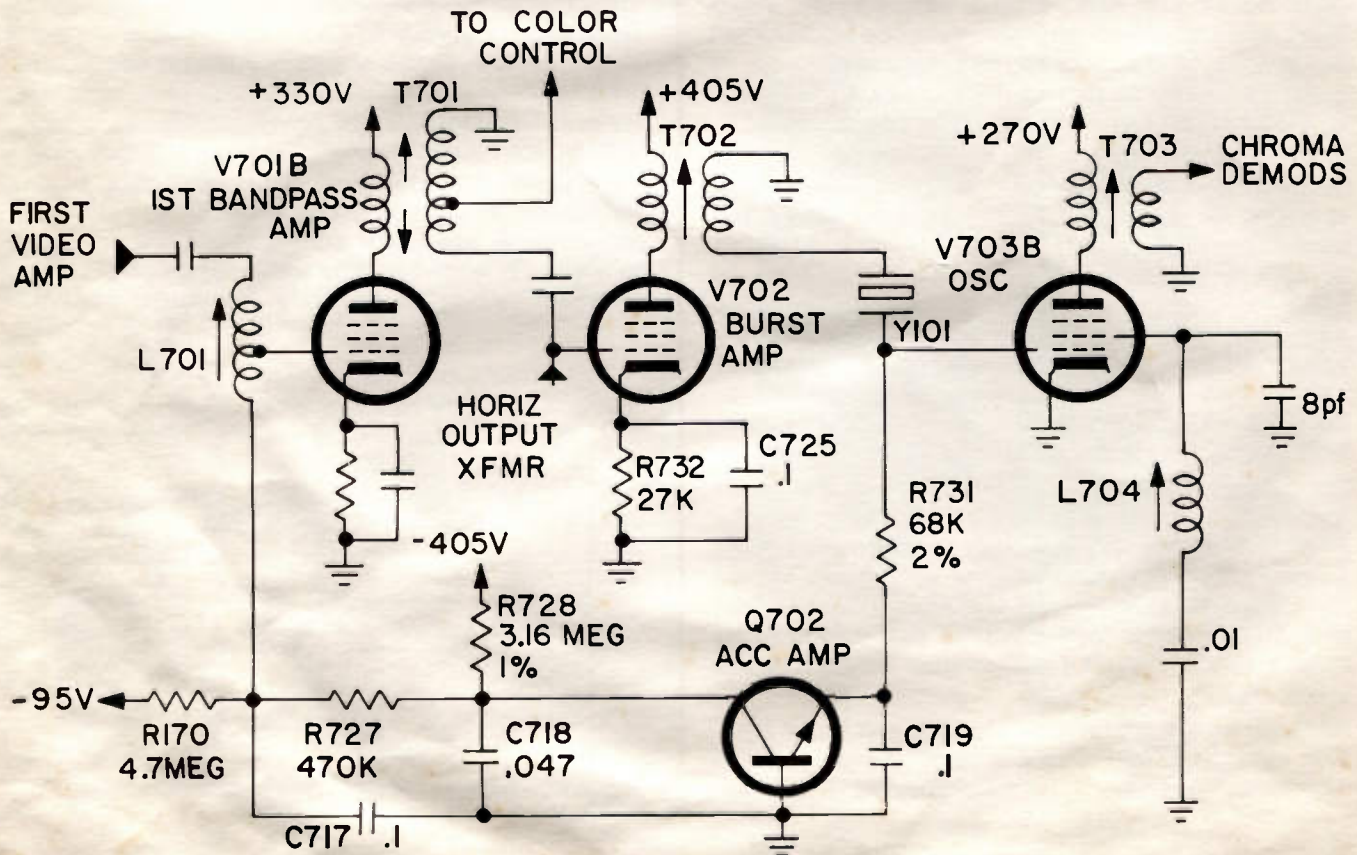

Figure 2 — Simplified ACC for CTC-38



Solid-State Horizontal Deflection PART TWO

In Part I, the general features of the deflection system and the details of the retrace circuit were discussed. In this concluding part, the operation of the circuit during scanning time and the method of high-voltage regulation are discussed.

At the end of retrace, the yoke current is 4 amperes, but the circuit through the retrace switch is open. However, there is a circuit path available through diode CR 1 of the trace switch, as shown in Figure 3. The complete path is from the top of the yoke, down through CR 1 to ground, and up through C1 to the yoke. This circuit is resonant at the correct frequency for trace operation.

At the center of trace, yoke current has decayed to zero (because of resonance); however, if a path is available, current is ready to increase in the opposite direction. During the first half of trace, a positive voltage is obtained from the circuit which supplies energy to the deflection system, and this voltage is supplied to the gate of SCR 1. Therefore, when the yoke current reverses at mid-trace, SCR 1 is ready to conduct and current flows in the circuit consisting of SCR 1, the yoke, and C1. This current increases to about 4 amperes at the end of trace, at which time SCR 2 is caused to conduct and the entire cycle of operation is repeated.

It may be correctly inferred from the foregoing discussion that energy to the yoke is supplied from C2 during retrace. Also during retrace, energy from this same source is supplied to the high-voltage transformer, since it is parallel with the

yoke. However, the transfer of energy from the power supply to C2 remains to be explained.

The basic circuit which supplies energy to C2 is shown in Figure 4. During retrace, the retrace switch is closed, isolating T1 and T2 from the rest of the deflection circuit. Thus, there can be no transfer of energy from the power supply to C2 during this time. (It should be noted that B+ is returned to ground via T1, T2, and either SCR 2 or CR 2 during retrace, but the current through an inductor must rise slowly and the "short" is removed before the current in either T1 or T2 becomes appreciable.)

During the much longer trace interval, the retrace switch is open and the trace switch is closed, completing the charging path for C2. Because the circuit is resonant at the proper frequency, the voltage across C2 reaches the crest of a sinusoidal rise just before the initiation of the next retrace. The voltage across C2 has begun to decrease from this peak value by the time retrace is initiated and it is typically somewhat less than 300 volts. The energy stored in the capacitor at this moment then is transferred to the yoke and the high-voltage transformer.

The current which flows through T1 during trace induces a positive voltage in the secondary winding. This positive voltage is supplied to the gate of SCR 1 in the trace switch, allowing it to conduct during the second half of trace.

High-voltage regulation is achieved by controlling the resonant frequency of the charging circuit of

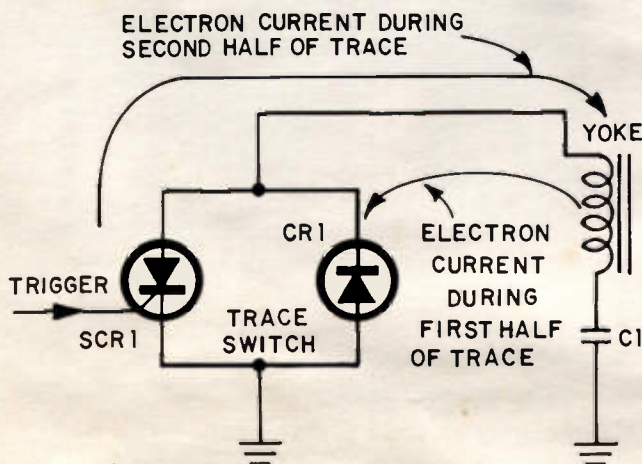

Figure 3 — Basic Trace Circuit

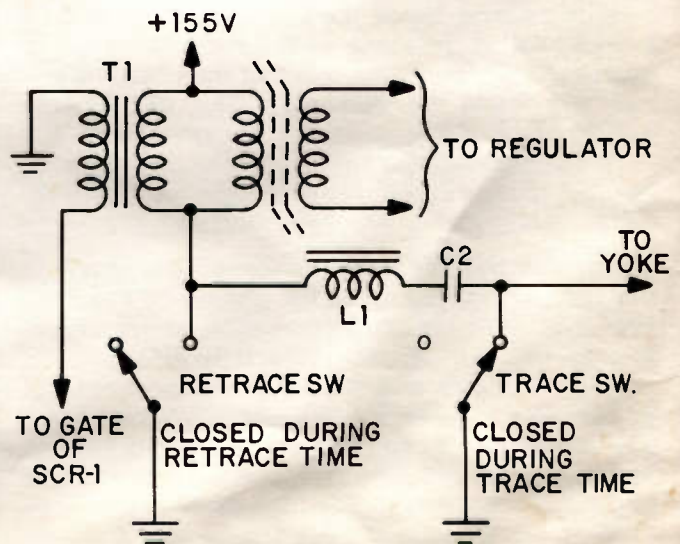

Figure 4 — Charging Circuit for C2

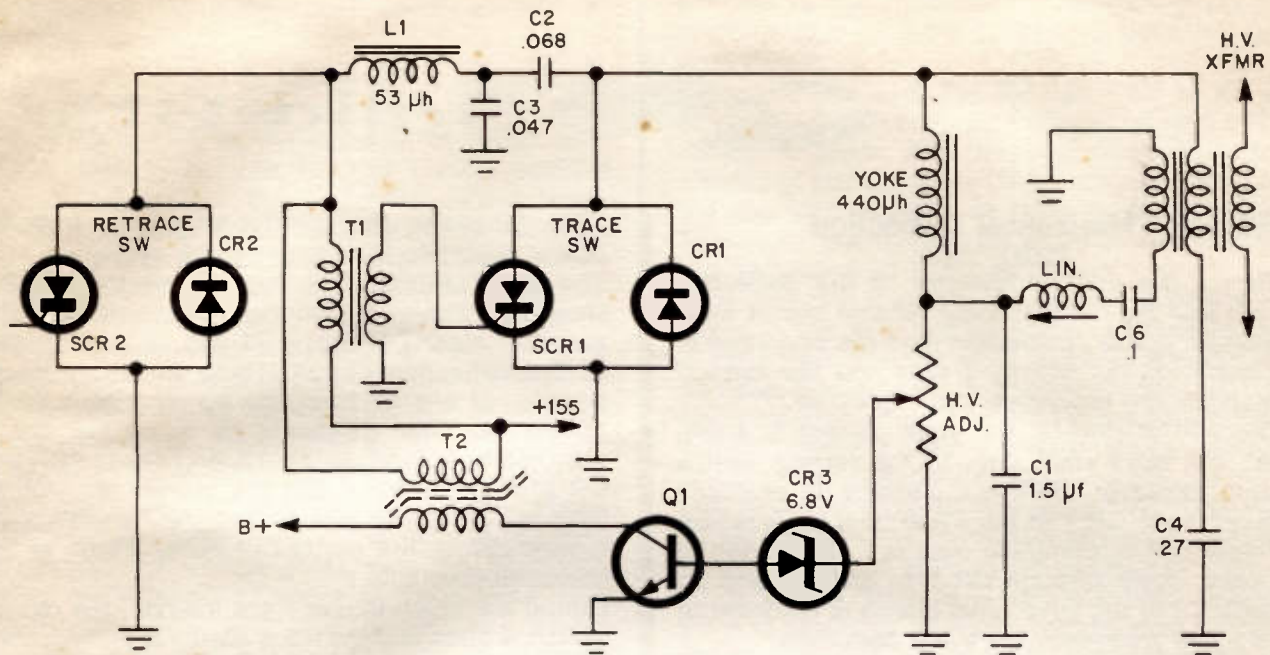

Figure 5 — Simplified Horizontal-Deflection Circuit

C2. If the resonant frequency is increased, the voltage across C2 will reach its crest more rapidly and, of course, it will decay to a lower value before the initiation of the next retrace. Conversely, if the frequency is lowered the voltage crest will occur later and the voltage across C2 will be greater when the next retrace is initiated.

Referring to Figure 5, assume that a comparatively dark scene is being transmitted, causing beam current to diminish and high voltage to rise. This causes a corresponding rise in the positive voltage present on C1 during the latter part of the trace period, and this, in turn, causes collector conduction of Q1 to increase.

T2 is a saturable reactor; i.e., increasing the current through the control winding (connected to the collector of Q1) decreases the inductance of the primary winding. Since the primaries of T1 and T2 are parallel, a decrease in the inductance of T2 decreases the total inductance of the charging circuit and **raises** the frequency. This causes less energy to be available in C2 for transfer to the yoke and high-voltage transformer during the subsequent retrace cycle, and therefore the high-voltage is stabilized.

Although it has not been mentioned previously in this discussion, capacitor C3 (Figure 5) has considerable influence on the operation of the deflection circuit. During trace time it is effectively in parallel with C2 and receives energy from the power supply. During retrace time, C3 makes available two additional currents paths (besides the one shown previously). One of these circuits consists of C3, C2, the yoke, and C1; the other circuit consists of C3, L1, and the retrace switch. Calculation of the instantaneous currents in these three circuits is a very complex process which is be-

yond the scope of this discussion. The effect of incorporating C3 in the circuit is three-fold. It provides additional energy to the yoke; it increases the resonant frequency of the yoke circuit during retrace, thus decreasing retrace time; and it improves the switching action of SCR 2 and CR 2.

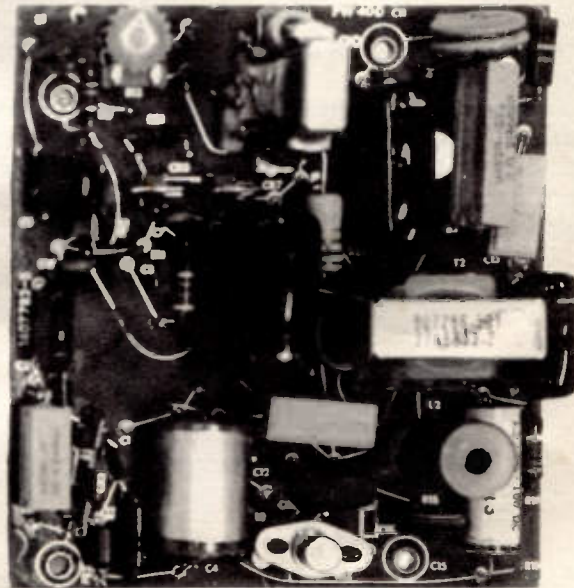

Figure 6 — Horizontal Deflection Board of CTC 40

RCA Sales Corporation

A Subsidiary of RCA Corporation
 Product Performance—Technical Training
 600 North Sherman Drive
 Indianapolis, Indiana 46201