

# PLAIN TALK

RCA RCA VICTOR 

## AND *Technical Tips*

VOL. **8**  
NO. **5**  
MAY 1965

a monthly publication for the service industry prepared by:

PRODUCT PERFORMANCE  
RCA SALES CORPORATION

### NEW SOLID STATE AMPLIFIERS

The wide selection of Solid State audio amplifiers offered by RCA includes the continuing RS-211B, a new version of the RS-209 and two new stereophonic amplifier chassis, the RS-216 and the RS-219.

The RS-209B power amplifier is a continued chassis that has undergone several revisions. The power supply has been changed to a full-wave center-tap bridge rectifier circuit. This circuit configuration supplies a positive and a negative voltage to the stacked output stage in each channel, thus placing the audio take-off point at zero volts potential which permits direct coupling to the speaker. The chassis layout has been revised to accommodate the new circuitry. Refinements have been added such as power transistor sockets and larger filter capacitors. A permanently attached line cord is now used.

The RS-216 chassis is a new dual channel solid state phono amplifier designed for use in stereophonic portable instruments. The chassis is transformer powered and utilizes a solid copper board, 10 transistors, and 2 silicon rectifiers.

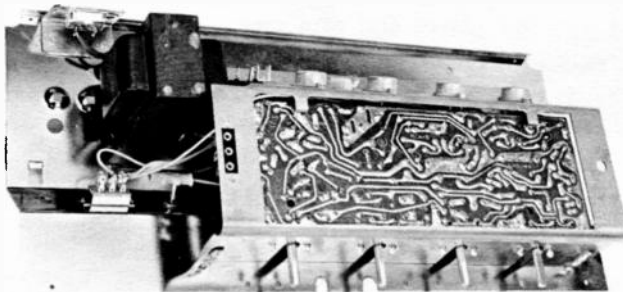

Figure 1—The RS 216 Amplifier

The circuit consists of a full wave power supply, two AF amplifier stages, two driver stages, and two stacked class B output stages. The printed wiring board is mounted to a metal frame on which the output transistors and power transformers are also mounted. The RS-216 has four chassis controls for loudness, bass, treble, and balance.

The RS-219 chassis is electrically similar to the RS-216. The chassis is designed for use in stereophonic console instruments.

(Continued on Page 2)

### RC-1223/RS-215 CHASSIS SERIES

A new AM/FM tuner and audio amplifier assembly was recently announced by RCA. This all solid state system will have broad applications in many Radio/"Victrola" and Television combination instruments.

There are four separate versions of RCA's new RC-1223/RS-215 combination chassis used in the 1966 instrument line. Each of these four versions employ a specific RC-1223 tuner chassis, and a specific RS-215 amplifier chassis. Various versions of this tuner and amplifier chassis are combined (physically and electrically (to form one integral assembly. When used in conjunction with a specific RK-314 power supply chassis, this assembly makes a complete receiving system.

#### Tuner Chassis

There are two versions of the RC-1223 tuner chassis. The "A" version is an AM/FM tuner containing 7 transistors and 4 diodes. The "B" version is an AM/FM/FM-Stereo tuner, using 11 transistors and 10 diodes; the "B" version has multiplex circuitry for the reception of FM-Stereo. These all-transistor tuner chassis have all components mounted on a single solid copper circuit board; the board is mounted to a metal frame which contains the tuning mechanism and slide rule dial. This frame is designed to always be, in turn, mounted to an amplifier chassis (RS-215) to make a single unit for installation in an instrument.

(Continued on page 2)

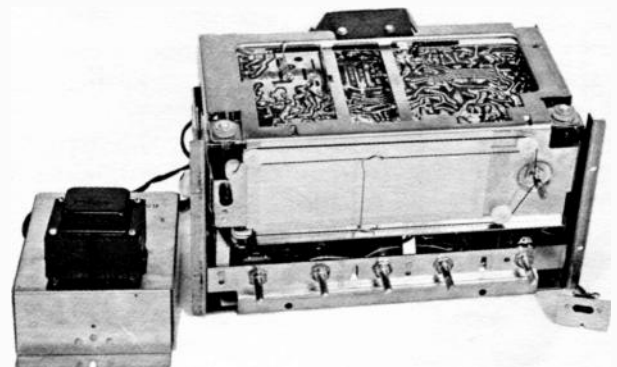

Figure 2—The RC 1223/RS 215/RK 314

## NEW SOLID STATE AMPLIFIERS

(Continued from page 1)

The mounting frame for this chassis is formed in the shape of a "U". The chassis made in two pieces which are fastened together. The piece that has the

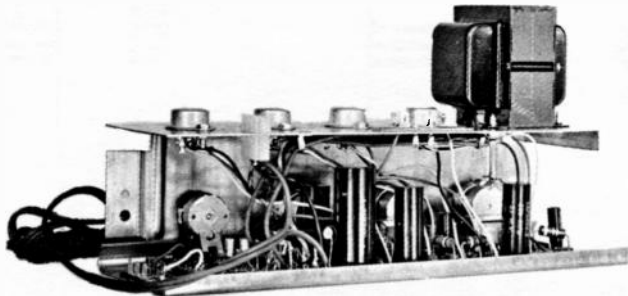

Figure 3—The RS 219

output transistors mounted on it may be unfastened from the circuit board frame for easier servicing on this chassis.

## PERSONAL AND TABLE RADIOS

A full selection of personal and table radios are included in the 1966 product line. With the exception of four table model radios, all chassis use Solid State design.

The RC-1220 is a completely new, line operated, transistor AM/FM radio chassis used in certain table model instruments. The chassis utilizes 11 transistors and 6 diodes (including rectifiers). A ferrite rod antenna is provided for AM reception, a line cord type antenna for FM reception.

The RC-1221 is a new addition to the radio line. Circuitry of this personal AM receiver includes 8 transistors and 1 diode. The receiver is powered by 4 "C" cells, and is equipped with an earphone jack.

The RC-1222 is an 8 transistor and 1 diode AM pocket radio. A 9 volt (VS323 or equivalent) battery is used to power this chassis.

The RC-1224 is a new 6 transistor and 2 diode (including rectifier) AM radio chassis. This power transformerless chassis is designed for use in certain table radios and clock radios.

Model RGM 19 is a "pocket" type, 9 transistor AM/FM radio receiver designed to operate on a 9-volt dry cell (RCA VS323 or equivalent).

Model RGM 29 is a portable-type AM/FM radio receiver powered by four 1.5 volt "AA" size dry cell batteries. A total of 9 transistors and 5 diodes are used.

The Model RGM 39 is a 10 transistor, pocket AM/FM radio receiver. Power is supplied by four "AA" cells.

Model RGM 49 is an AM/FM portable type radio receiver utilizing 10 transistors and 6 diodes. The chassis is powered by four 1.5 volt "C" cells.

All of the RGM series feature a telescopic rod antenna for FM reception.

## RC-1223/RS-215 CHASSIS SERIES

(Continued from page 1)

Each version has separate RF amplifier and converter stages for AM and FM, three IF amplifier stages (two used for AM, three for FM), and separate demodulation stages for AM and FM. A ferrite antenna is used for AM pickup and folded dipole is used for FM pickup. Outside FM antenna terminals are available on the rear.

### Amplifier Chassis

The RS-215 is a new 10 transistor, dual channel amplifier chassis, contained on a "Solid Copper Circuit" wiring board. This board is mounted to a metal frame which is designed to be mounted to the frame of the RC-1223 tuner to make a single unit.

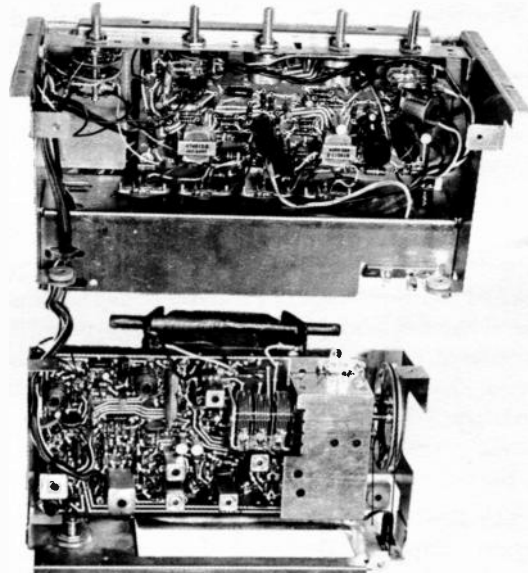

Figure 4—The RC 1223 and RS 215

The audio and driver stages are contained on the board; the output transistors are mounted on the metal frame. Jacks are provided for the connection of a record player and of a tape recorder.

One of four versions of the new RS-215 amplifier chassis will be used with one of the "1223" radio chassis to form a tuner-amplifier unit.

## NEW CERAMIC CARTRIDGE

RCA's newly engineered ceramic pickup permits easier service of the stylus and/or pickup. Removal of the stylus is a simple operation. All that is necessary to remove the stylus is to grasp the flipover lever, and pull the stylus up and out. Re-insertion of the stylus is also a simple operation: merely slip it under the metal retainer (again utilizing the flipover lever) and press the assembly inward toward the cartridge. A definite snap-in action will ensure that the stylus is properly seated. It is no longer necessary to remove the pressure pad to replace the stylus.

RCA Victor Radio/"Victrola" products employ solid state devices in almost every instrument. Some examples of the extended use of semiconductors and transistors are illustrated in this month's solid state article.

**RC-1223 FM-Stereo**

In the RC-1223B multiplex circuits, both monophonic FM and stereophonic FM is fed directly to the base circuit of the first 19 KC amplifier. This stage functions as an emitter follower, providing good impedance matching for both monophonic and stereo FM signals. From the emitter, mono FM passes through the de-emphasis network, through the signal switches, and to the audio amplifiers. The composite FM-Stereo audio available at the emitter is coupled into the left and right demodulator circuits.

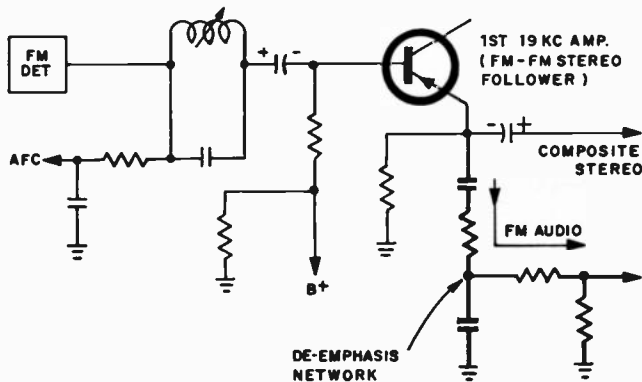

Figure 5—RC 1223—1st 19kc Amplifier

The 19 KC pilot signal is processed by the first and second amplifier stages, doubled to 38 KC, and fed to the 38 KC amplifier. The synchronous detectors for the left and right FM-Stereo signals and the operation of the stereo switch stage is similar to that used in RCA's previous RC-1218 tuner. After demodulation, the left and right FM audio signals are fed to their respective channels via the function switch.

**Output Transistor Sockets**

A new power output transistor socket assembly is used in many Radio Victrola products which use power output transistors. The sockets have self-aligning shoulders on the mounting holes which center the assembly in the holes in the chassis. This mounting method ensures correct orientation of the transistor in the socket and eliminates the possibility of the base or emitter pins of the transistor making contact with the chassis.

Mica spacers and silicone grease are used to insulate the transistor body from the chassis while providing good heat transfer. The socket arrangement makes for a neat, serviceable mount for output transistors.

Whenever a power transistor is removed for service, be sure to reinstall the mica spacer with a silicone grease coating on both sides.

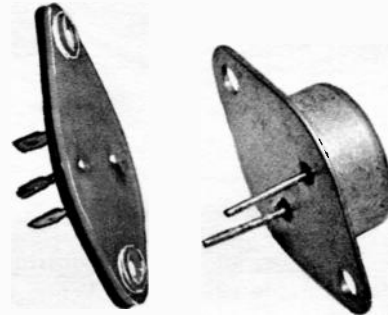

Figure 6—Output Transistor Socket

**RK-314 Power Supply Chassis**

The RK-314 power supply chassis is designed to be used with the RC-1223/RS-215 tuner/amplifier unit. There are three versions of this chassis.

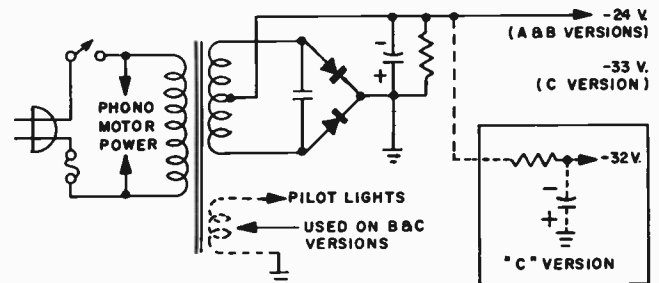

Figure 7—RK 314 Power Supply

The schematic for the supply circuit illustrated here is representative of the RK-314A, B and C series. Two silicon rectifiers, in a full-wave supply circuit, develop a —24 volt supply for the A and B versions. There are three different power transformers used in the RK-314 series: The "A" version has no provisions for a pilot light; the transformer in the "B" version has provisions for a pilot light, although the output voltage (—24 volts) remains the same; the power transformer used in the "C" version has provisions for pilot light power, and voltage windings to develop a higher output voltage (approximately 33 volts). Inter-connecting plug and sockets are used to connect the power supply to the tuner/amplifier chassis. Protection for the power supply and complete receiver system is provided by a 2-amp line fuse located on the power supply chassis.

## NEW STUDIO STROBE CHANGER

The RP-218C-12S "Studio Strobe" record changer is used in several top-of-the-line models. In addition to all of the features of the RP-218 changers, this changer is equipped with a stroboscopic indicator, and a variable speed motor.



Figure 8—Studio Strobe Changer

The Strobe Window, and Strobe Control knob are located on the turntable base plate. When the Strobe Control knob is depressed, a light in the Strobe Window illuminates four rows of dots, each row of dots corresponding to a speed indicated by the Speed

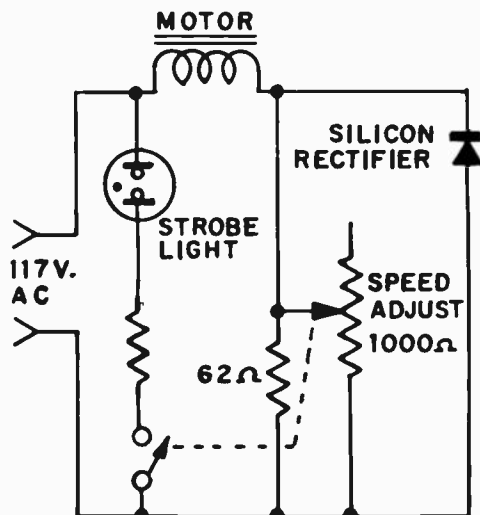

Figure 9—Studio Strobe Circuit

Selector knob. The row of dots corresponding to a particular speed will be visible as distinct dots at that speed, and the other rows will be blurred. The distinct dots may seem to drift slightly (either forward or backward) and may be "stopped" as follows: Depress Strobe knob until it clicks, and hold in this position; then adjust Strobe knob in the direction required until dots appear to be motionless. The turntable speed will now be correct.

The motor circuit includes a rheostat, silicon rectifier, and shunt resistor. The motor speed is varied by the ratio of AC to DC voltage. The DC com-

ponent obtained from the rectifier circuit has effect of changing the efficiency of the motor, and thus, the speed. The strobe indicator is a neon bulb, with a series resistor. The indicator switch is spring loaded to the off position. The components associated with the motor circuit are located under the turntable.

## RECORD CHANGERS

A new look in record changers for 1966 is accomplished by new styling and the use of new pickup arms and stabilizer arms. New cartridges are used in many models. All changers are four speed types, and are capable of playing intermixed records of all sizes."

The changers used in high-end instruments employ a completely new ceramic pickup using a flipover stylus. RCA's new ceramic pickup features smooth frequency response, high compliance, and low stylus tracking force.

Three versions of the RP-217 series and RP-218 series are employed in consoles and top-of-the-line portables. The RP-218C-12S "Studio Strobe" is a new changer, equipped with a stroboscopic indicator and a variable speed motor circuit.

Several of the RP-219 changers will use a crystal pickup; both the stereo and mono versions will use a single, multi-purpose sapphire stylus. Two of the RP-219 series changers have operating controls mounted on a panel separate from the changer.

## RCA SALES CORPORATION

600 NORTH SHERMAN DRIVE  
 INDIANAPOLIS, INDIANA 46201  
 A RADIO CORPORATION OF AMERICA SUBSIDIARY  
 Tmks. © Reg. U. S. Pat. Off.