

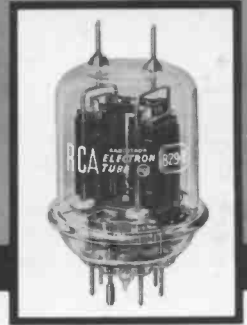

# HAM TIPS



A PUBLICATION OF THE RCA ELECTRON TUBE DIVISION

VOL. 22, NO. 2

©1962, RADIO CORPORATION OF AMERICA

SUMMER, 1962

## A 120-WATT 50-MC TRANSMITTER

By George D. Hanchett, W2YM

RCA Semiconductor and Materials Division.

Somerville, N. J.

Although an active ham for more than three decades, the author had never tried transmission on six meters—until this year. Preparatory steps involved the usual search around the shack for parts suitable for a low-powered rig. W2YM decided that only the rf unit and antenna had to be built. Power supplies and the modulator were borrowed from a two-meter transmitter. The available power supplies limited the rig to a power level of about 100 watts. Because the author's location is in a Channel-2 area, the 120-watt 50-megacycle transmitter—well shielded throughout—is of proved straightforward design.

### Tube Locations and Circuit Considerations

Initial step in planning the 120-watt 50-megacycle transmitter was to lay out a three-stage rf section having a VFO-driven multiplier or crystal oscillator as the first stage and an RCA-829B as the final stage (see Figure 1).

An RCA-12BY7A oscillator-tripler was arranged so that it operates as a grid-plate oscillator in the crystal-control position. This oscillator uses 8-megacycle crystals and its output is tuned to the third harmonic. In the VFO position, the 12BY7A stage can be either an amplifier or a multiplier, and can be driven by a VFO with 8-, 12-, or 25-Mc output.

The oscillator-multiplier is capacitively coupled to an RCA-2E26 doubler which has a 50-Mc output. The 2E26 is link-coupled to the grids of the 829B. Link coupling was used because it facilitates coupling of a single-ended stage to push-pull grids.

In addition, the use of the double-tuned circuit provides extra selectivity in the grid circuit of the 829B amplifier and, thereby, reduces the possibility of harmonic interference to FM and TV reception.



Front view of W2YM's 120-watt 50-megacycle transmitter. [Note the air-intake holes on the side of the blower (or bottom) chassis. They each measure 3/8 inch in diameter.]

The 829B final-amplifier plate circuit is tuned by a butterfly capacitor. The rotor section of this capacitor is ungrounded to improve balance. The antenna is link-coupled to the final tank circuit and is equipped with a 50-micromicrofarad capacitor which tunes out the inductance of the link winding.

Metering of different circuits is accomplished by use of a 0-1 milliampere meter. Suitable meter shunts are used in order to meter oscillator plate current (30 milliamperes full scale), doubler-grid current (2 ma full scale), doubler plate current (100 ma full scale), final grid current (30 ma full scale), final screen-grid current (100 ma full scale), and final plate current (300 ma full scale). A tuning switch is incorporated because it not only aids in the tune-up procedure, but also saves tubes and prevents possible damage to other components.

### Construction

Completely contained in a 12- by 7- by 6-inch aluminum utility box, the 50-megacycle

Top view of inside of utility box shows details of grid and plate circuit for the 829B. Also note that a portion of the utility-box flanges have been removed to allow for insertion of subchassis.

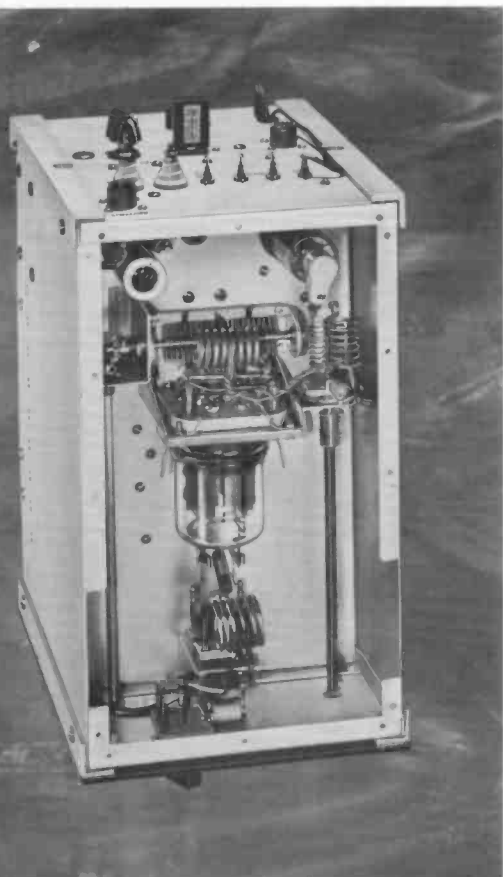

transmitter is fitted with an aluminum subchassis. This subchassis has small, 1/2-inch lips which are bent on the long sides of the chassis to provide stiffness.

Half-inch tabs—bent on the front and rear of the chassis—serve as mounting brackets. One set of these tabs is bent up, the other down. Without this feature it would be impossible to insert the subchassis into the utility box.

For the same reason, two slots are cut in the top flanges of the utility box. These slots are visible in the photograph at left, which shows a top view of the transmitter.

A rectangular cutout at the rear of the subchassis fits around the power-lead filters which are mounted on the rear wall of the utility box. All leads entering or leaving the utility box are brought out through low-pass filters.

When complete, the utility box is mounted on a 12- by 7- by 3-inch aluminum chassis that serves as a bottom cover as well as a housing for the cooling fan and filament transformer. (The schematic for the bottom chassis is shown in Figure 2.)

A right-angle drive for the final-amplifier grid capacitor was made from two brass-beveled gears manufactured by the Boston Gear Works. These gears (stock item No. G462Y) have a 3/16-inch shaft hole which must be enlarged to accommodate 1/4-inch shafts. (The use of a lathe is recommended for this machining. If you do not have access to a lathe, a machine shop will do it for you at a nominal fee.) Each gear is secured on its shaft with two Allen-set screws spaced 90 degrees apart.

As shown in the sketch of the grid assembly (see Figure 3), the socket, grid coil, and neutralizing capacitors for the 829B are mounted on an aluminum bracket. The two top-mounting screws of the socket, together with a polyethylene strip, are used as feed-through connections.

The holes in the brackets must be enlarged so that the neutralizing capacitors do not short to ground. In the Figure 3 sketch, these holes are enlarged to 3/8 inch.

Note that, during construction, the grid leads of the 829B are criss-crossed. The neutralizing capacitors are small pieces of No. 12 wire which are close to the plate region of the 829B. Neutralization is accomplished by adjustment of the length of these wires, as described below.

The heater, screen-grid, and control-grid by-pass capacitors (as well as the output capacitor of the low-pass filters for the meter

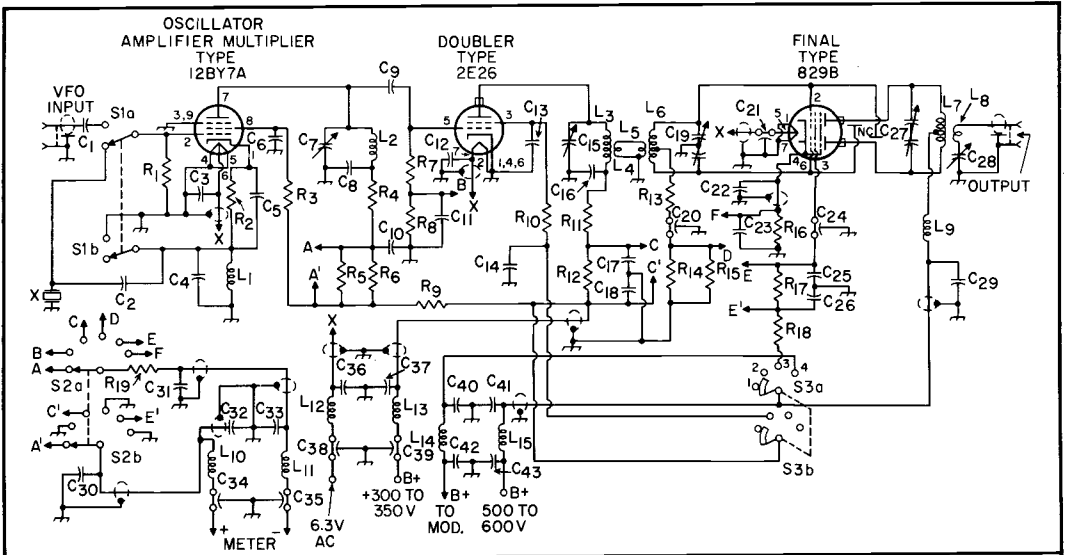

- C<sub>1</sub>—220 pf, mica, 500 volts
- C<sub>2</sub>—10 pf, mica, 500 volts
- C<sub>3</sub>, C<sub>5</sub>, C<sub>6</sub>, C<sub>8</sub>, C<sub>10</sub>, C<sub>11</sub>, C<sub>12</sub>, C<sub>13</sub>, C<sub>14</sub>, C<sub>16</sub>, C<sub>17</sub>, C<sub>18</sub>, C<sub>22</sub>, C<sub>23</sub>, C<sub>25</sub>, C<sub>26</sub>, C<sub>30</sub>, C<sub>31</sub>, C<sub>32</sub>, C<sub>33</sub>, C<sub>36</sub>, C<sub>37</sub>—1,000 pf, disc ceramic, 1,000 volts
- C<sub>4</sub>—100 pf, mica, 500 volts
- C<sub>7</sub>, C<sub>28</sub>—3.7-52 pf, variable, air gap 0.015 inch (Hammarlund HF-50 or equiv.)
- C<sub>9</sub>—47 pf, mica, 500 volts
- C<sub>15</sub>—5.2-30 pf, variable, air gap 0.045 inch (Hammarlund HF 30-X or equiv.)
- C<sub>19</sub>—5.0-28.5 pf double-section variable, air gap 0.045 inch (Hammarlund HFD 30-X or equiv.)
- C<sub>20</sub>, C<sub>21</sub>, C<sub>24</sub>, C<sub>34</sub>, C<sub>35</sub>, C<sub>38</sub>, C<sub>39</sub>—1,000 pf, feed-through, ceramic, 500 volts
- C<sub>27</sub>—4.8-27.3 pf, butterfly, variable, air gap 0.030 inch (Hammarlund BFC-25 or equiv.)
- C<sub>29</sub>, C<sub>40</sub>, C<sub>41</sub>, C<sub>42</sub>, C<sub>43</sub>—1,000 pf, disc ceramic, 3,000 volts
- L<sub>1</sub>—RF choke, 1 mh
- L<sub>2</sub>—10 turns of No. 20 tinned on ½-inch diameter form, winding length ¾ inch

- L<sub>3</sub>—5½ turns of No. 10 solid on ⅝-inch diameter, winding length 1 inch
- L<sub>4</sub>, L<sub>5</sub>—2 turns of No. 20 plastic covered on ½-inch diameter
- L<sub>6</sub>—8 turns of No. 10 solid on ⅝-inch diameter, winding length 1½ inches
- L<sub>7</sub>—6 turns of No. 10 solid on ⅝-inch diameter, winding length 1 inch
- L<sub>8</sub>—2 turns on No. 14 Enam. covered with insulation tubing on ⅝-inch diameter
- L<sub>9</sub>, L<sub>10</sub>, L<sub>11</sub>, L<sub>13</sub>, L<sub>14</sub>, L<sub>15</sub>—RF choke, 7 μh, 1,000 ma (Ohmite Z-50 or equiv.)
- L<sub>12</sub>—RF choke, 25 turns of No. 16 Enam. close-wound on ¼-inch diameter
- NC—Neutralizing capacitors: No. 12, tinned wire (½-inch length placed in proximity of 829B plates); see text
- R<sub>1</sub>—100,000 ohms, 0.5 watt
- R<sub>2</sub>—120 ohms, 0.5 watt
- R<sub>3</sub>—33,000 ohms, 0.5 watt
- R<sub>4</sub>, R<sub>8</sub>, R<sub>11</sub>, R<sub>19</sub>—1,000 ohms, 0.5 watt
- R<sub>5</sub>, R<sub>14</sub>—47 ohms, 0.5 watt
- R<sub>6</sub>, R<sub>15</sub>—130 ohms, 0.5 watt
- R<sub>7</sub>—47,000 ohms, 1 watt

- R<sub>9</sub>—3,300 ohms, 1 watt
- R<sub>10</sub>—10,000 ohms, 2 watts
- R<sub>12</sub>—10 ohms, 0.5 watt
- R<sub>13</sub>—56,000 ohms, 2 watts
- R<sub>16</sub>—3.3 ohms, 0.5 watt
- R<sub>17</sub>—33 ohms, 0.5 watt
- R<sub>18</sub>—15,000 ohms, 10 watts, wire wound
- S<sub>1</sub>—Crystal-VFO Switch; two-pole, two-position, wafer, non-shorting, rotary
- S<sub>2</sub>—Meter Switch; two-pole, six-position, wafer, non-shorting, rotary
- S<sub>3</sub>—Tuning Switch; 60-degree indexing (Centralab PA-304 or equiv.); two progressively shorting 30-degree wafers (Centralab PA-12 or equiv.), using every second contact
- Miscellaneous—One crystal socket; one 829B socket; one octal socket; one 9-pin min. socket and shield; one 6- x 7- x 12-inch utility box; one 7- x 12- x 3-inch chassis; two ceramic feed-through insulators; two beveled gears, 90 degrees; one pilot light (green); one fuse; one cord set; one insulated plate cap (Millen or equiv.); two coaxial connectors (Amphenol or equiv.) **Note:** All resistors have 10% tolerance.

Figure 1: Schematic diagram and parts list of the rf section of W2YM's 50-megacycle transmitter.

leads, heaters, and 350-volt B+) are 0.001 μf FT feed-throughs. The high-voltage and modulator power-lead feed-throughs are ceramic units which are externally by-passed.

The tuning switch is constructed from a Centralab 60-degree detent assembly and two PA-12 progressively shorting wafers. In the first position, the screen-grid voltage is re-

moved from both the 2E26 and the 829B, as well as the plate voltage to the external modulator. Advancing the switch in a clockwise manner activates each stage in turn until, in the fourth position, the complete transmitter is in operating condition.

As previously mentioned, the filament transformer and cooling fan are mounted in

Bottom views of both utility box and blower chassis before assembly as combined unit. Note blower fan in the blower chassis. Also note that the 12 holes in the subchassis underneath the 829B allow for free flow of air around the tube.

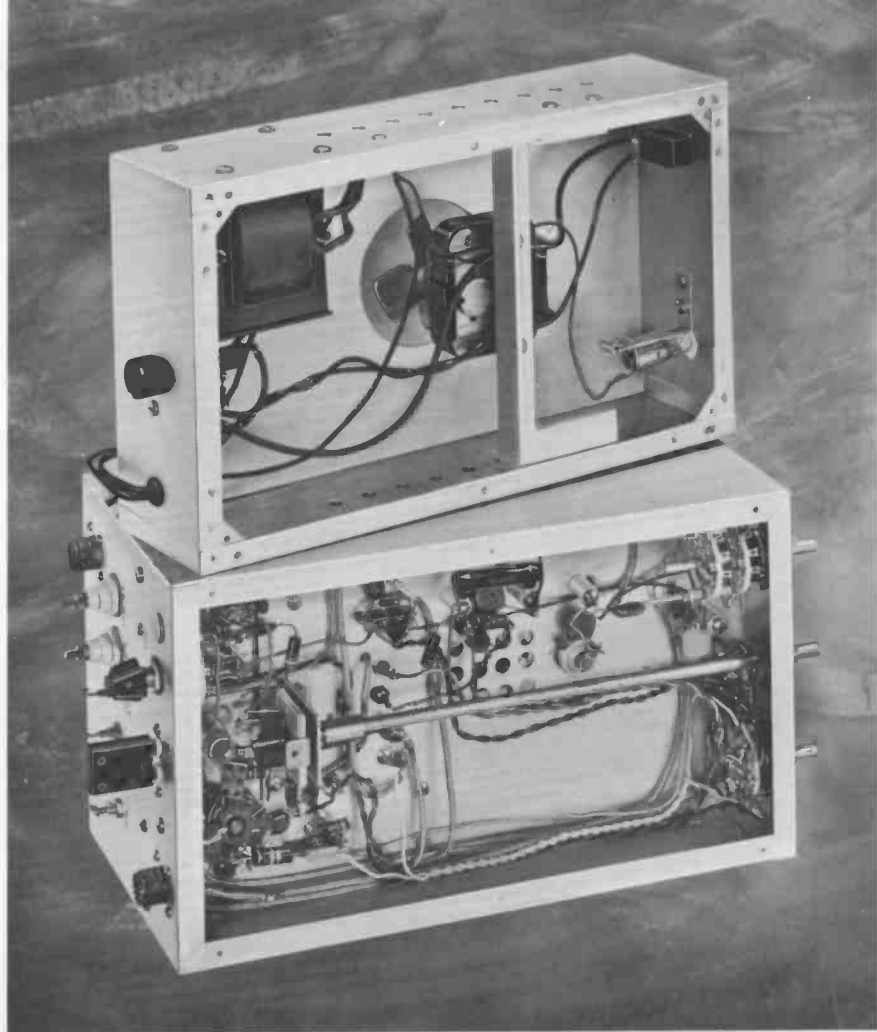

the blower (or bottom) chassis (Figure 2). The cooling-fan blade is positioned in a  $2\frac{3}{4}$ -inch hole in the blower chassis. Holes drilled in the sides of this chassis provide an air inlet for the fan. As a result, air is freely circulated around the 829B.

Although the bottom cover is one of the original utility box covers, the top cover is a piece of perforated aluminum. The utility box and the blower chassis are held together by four  $\frac{3}{4}$ -inch angles which can be made from "do-it-yourself aluminum." The front panel is cut from  $\frac{1}{8}$ -inch aluminum stock and fastened to the front aluminum angles of the transmitter. The panel may then be painted and lettered with decals.

In the transmitter, the 0-1 milliamperemeter is not included because it is an integral part of the power supply unit used. Figures 4 and 5 show the power supplies that have been successfully used with this transmitter.

#### Transmitter Adjustments

With the top and bottom covers removed and the utility box detached from the blower

chassis, make temporary connections to the heater circuit and ground the utility box to the blower chassis. Then, after checking all wiring, turn on the ac power to the fan and heater-filament transformer.

See that all tubes are properly lit. With the tuning switch in position No. 1, temporarily connect the 300-volt B+ to its proper terminal. Turn on the power and adjust  $C_7$  for the maximum grid current of the 2E26 (approximately 1.0 to 1.2 milliamperes). Turn the meter switch so that the oscillator plate current can be read. (This value should be between 12 and 18 milliamperes.) With a wave meter or grid-dip meter in the diode position, check that the plate circuit of the 12BY7A is three times the crystal frequency.

Shut off the plate supply and advance the tuning switch to position No. 2. Reapply the 300-volt B+ and quickly adjust  $C_{15}$  and  $C_{19}$  for maximum 829B grid current. Adjust the link coupling so that a grid current of approximately 10 milliamperes is flowing to the 829B grid. In making adjustments of the link coupling, be sure you turn off the B+

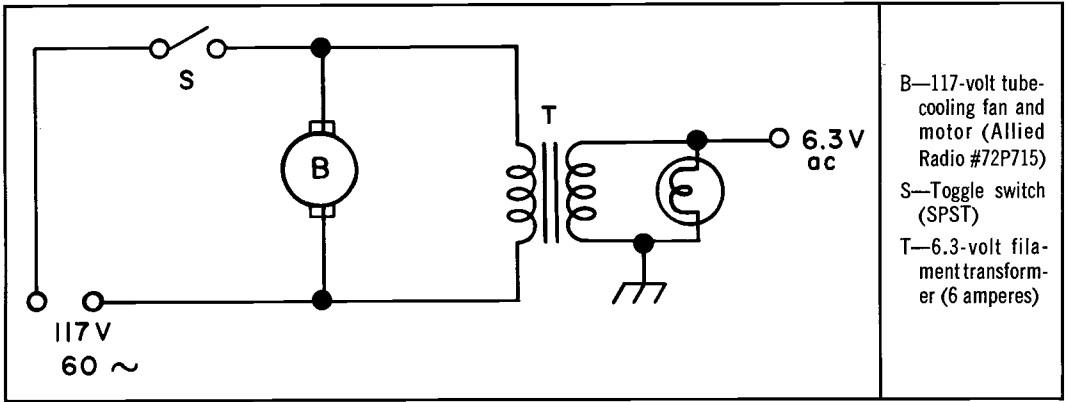

Figure 2: Schematic diagram and parts list of 50-megacycle transmitter's bottom chassis.

voltage because 300 volts is exposed at the 2E26 plate coil. At this point, by using a wave meter or grid-dip meter, check again that these circuits are on 50 megacycles.

If a dip in the grid-current occurs with excitation while  $C_{27}$  is tuned, the 829B neutralization must be adjusted by cutting  $\frac{1}{8}$ -inch lengths from the neutralizing wires

until there is no noticeable change in the grid current as  $C_{27}$  is tuned through resonance.

Next, connect a load to the antenna connector of the transmitter. (If you do not have a non-inductive 50- or 75-ohm load, a 100-watt light bulb can be substituted.)

Temporarily attach the 600-volt high-voltage lead to its proper terminal. With the tun-

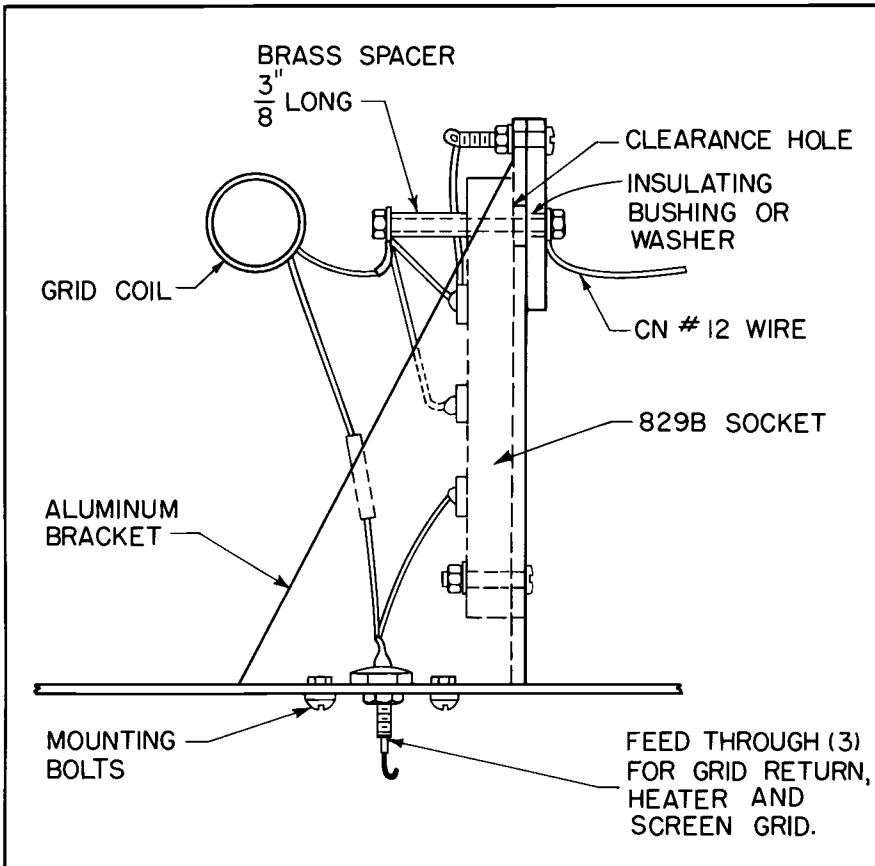

Figure 3: Sketch of grid assembly shows details of grid coil mounting and neutralizing capacitors.

ing switch in position No. 3 and the meter switch in the 829B cathode-current position, turn on the plate supplies. Quickly rotate the plate tank capacitor  $C_{27}$  for minimum dip. Now load the amplifier by adjusting  $L_8$  and  $C_{28}$  until the total cathode current is approximately 200 milliamperes.

Return the meter to the 829B grid position and adjust the link coupling between the 2E26 and the 829B until the grid current is 15 milliamperes. Again return the meter switch to the cathode-current position and adjust the loading until the cathode current is approximately 240 milliamperes.

The 829B screen-grid current should now be between 25 and 30 milliamperes. If the screen-grid current is above 30 milliamperes, the screen-grid dropping resistor must be increased; if below 25 milliamperes, it must be decreased. It is unlikely, however, that you will require any adjustment of this dropping resistor.

The utility box now can be assembled to the blower chassis. The bottom cover, as well as the top perforated cover, also can be permanently attached. The transmitter and modulator leads can be connected permanently, too. What else? Connect a six-meter antenna and you are ready to go on the air.

**A few words of precaution:** Never attempt to modulate this transmitter unless the 829B is completely loaded. If the transmitter is not loaded, flash-over will occur, since the butterfly capacitor voltage breakdown ratings will be exceeded. An output in the order of 75 to 85 watts should be attained.

### Tube Selection

Potential builders of this 120-watt 50-megacycle transmitter may be interested in knowing why particular tube types were selected. Here are the more important reasons:

- This writer was interested in attaining high reliability consistent with a moderate

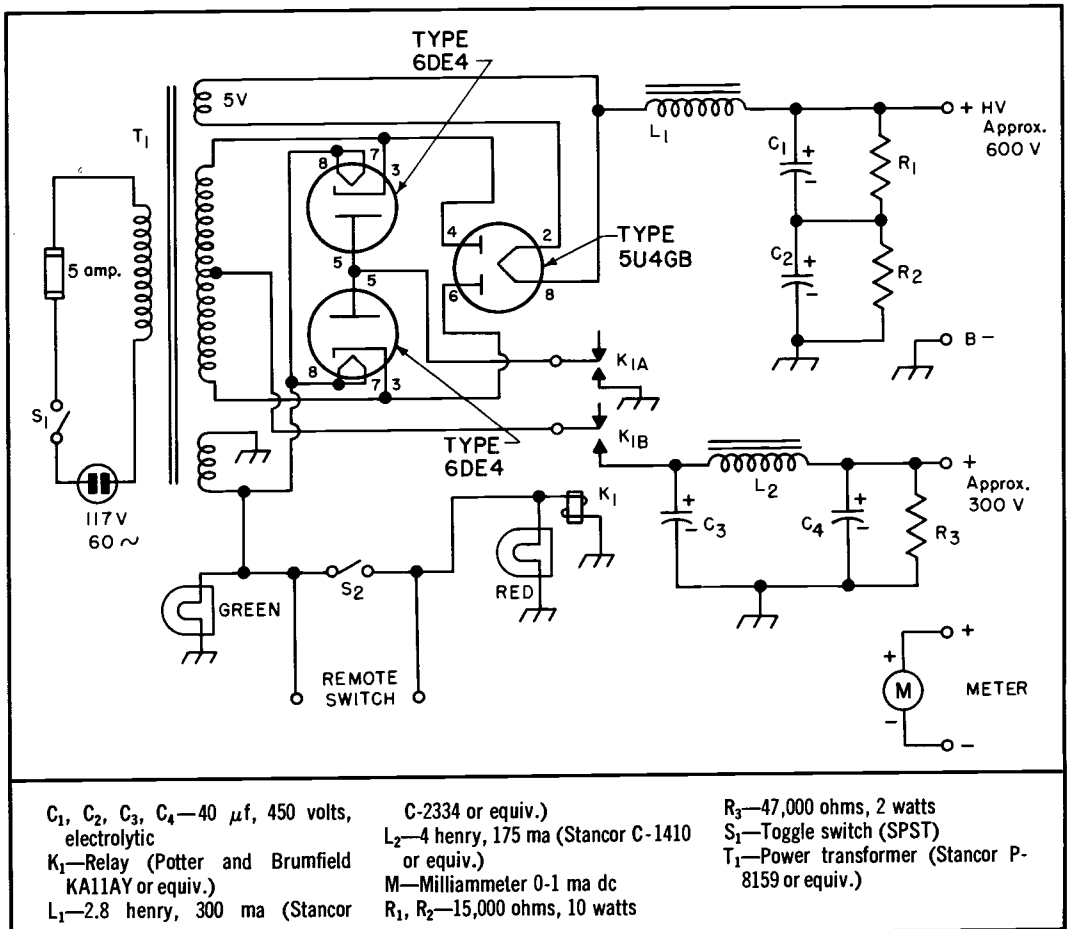

Figure 4: Schematic diagram and parts list of suggested power supply circuit using vacuum rectifier tubes.

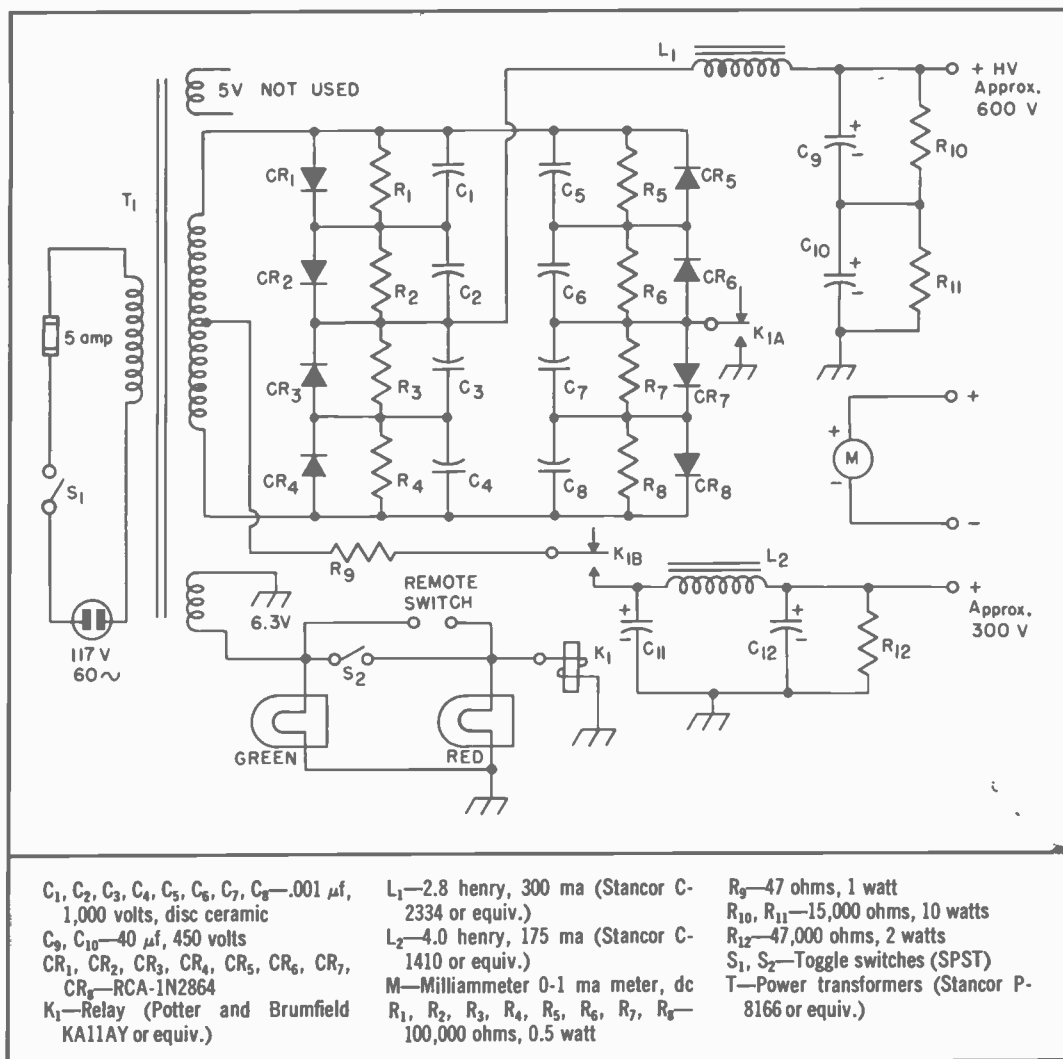

Figure 5: Schematic diagram and parts list of suggested power supply circuit using silicon rectifiers.

cost. The tubes chosen have been in production for many years and have demonstrated excellent life characteristics.

- Instead of the 829B, two 6146's could have been used for the final stage. However, the spacing and construction would have been much more difficult. In addition, while the 6146 would have cost less, the difference in price between this tube and the one used was not great enough to justify the extra mechanical problems that would have been brought about as a result.

- By replacement of the 2E26 with its 12-volt version (the 6893), and by rewiring of the 12BY7A and 829B, the transmitter can be used—with 12-volt heaters—in mobile installations.

All in all, the tube line-up selected appears to provide the best balance of power, cost, and reliability.



**NEW RC-21  
RCA RECEIVING  
TUBE MANUAL**

480 pages of current information on over 900 receiving types...plus basic electron tube theory, installation and application, 26 circuits using latest tubes. A completely revised receiving-tube "bible" for only \$1.00\* ... from your RCA Tube Distributor.

\*Optional list price



From your local RCA distributor, headquarters for RCA receiving and power tubes.

RCA HAM TIPS is published by the RCA Electron Tube Division, Harrison, N. J. It is available free of charge from RCA distributors.

Harvey Slovik, Editor

IF IT'S ELECTRONICS,  
CALL BARBEY'S FIRST

GEORGE D. BARBEY CO., INC.  
Reading Pottstown  
Lancaster Lebanon

BLK. RT.



Information furnished by the Radio Corporation of America is believed to be accurate and reliable. However, no responsibility is assumed by RCA for its use; nor for any in-

fringements of patents or other rights of third parties which may result from its use. No license is granted by implication or otherwise under any patent or patent rights of RCA.

TUBES SHOWN ACTUAL SIZE

**QRO**  
*plus!*

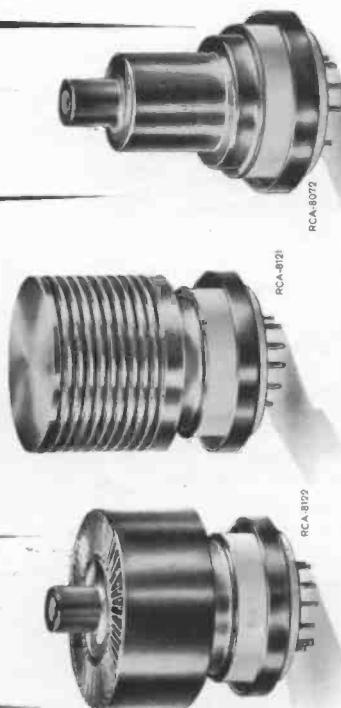

**RCA Announces three Ceramic-Metal Beam Power Tubes for Higher-Efficiency Operation on Amateur UHF**

You are looking at three of the most remarkable beam power tubes ever offered for amateur high-band operation. Ceramic-Metal construction makes them the toughest you can get for mobile service ... provides increased heat-handling capacity—reduces tube size for compact UHF transmitter designs. High-perveance design enables you to achieve UHF power output at relatively low plate voltages. RCA-8072, RCA-8121, and RCA-8122 are manufactured with the RCA exclusive grid-making technique for precision grid alignment and exceptional structural stability. Each tube features a 13.5-volt heater. See chart at right for plate voltages, useful power outputs, and operating frequencies for typical CW operation.

When you build or buy for high-band operation—SSB, AM, or CW—you'll get top results with an RCA Ceramic-Metal beam power tube. See your RCA Industrial Tube Distributor for the types you need.

NEW RCA CERAMIC-METAL TUBES FOR AMATEUR USE					
RCA No.	Type of Cooling	Plate Volts	Eff. %	Useful Power Output	Watts
8072	Conduction	700	50 175	50 105	110 105
8121	Forced-Air	1500	470	85	235
8122	Forced-Air	2000	500	up to	300
			500	up to	500

For a technical bulletin on RCA-8072, RCA-8121, or RCA-8122, please contact Commercial Engineering, RCA Electron Tube Division, Harrison, N. J.



THE MOST TRUSTED NAME IN ELECTRONICS