

HAM TIPS

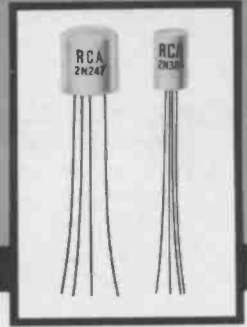

A PUBLICATION OF THE RCA ELECTRON TUBE DIVISION

VOL. XVIII, No. 2

© 1958, RADIO CORPORATION OF AMERICA

APRIL, 1958

A TRANSISTORIZED GRID-DIP METER

By Clarence A. West, W21YG

RCA Electron Tube Division, Harrison, N. J.

Like the VTVM, the grid-dip meter has become an important instrument, actually a necessity, for all serious-minded designers and builders of multiband communications equipment. In view of the fact that valuable tubes in a power amplifier can be ruined by operation of the amplifier with a plate tank circuit incapable of resonance, a grid-dip meter is inexpensive insurance. Because this instrument can also be used for other applications such as a wavemeter, signal generator, or field strength meter,

an up-to-date amateur station can hardly afford to be without one.

Part I of W21YG's two-part article, beginning in this issue, contains a description of the grid-dip meter designed and constructed by the author, along with details of its construction. A schematic diagram and parts list, as well as close-up views of the instrument, are also featured.

Instructions on the operation and use of this grid-dip meter will be given in Part II.



The transistORIZED grid-dip meter described in this article measures only $2\frac{1}{4}$ by 3 by $5\frac{1}{4}$ inches. It can be held and operated with one hand.

Basically, a grid-dip meter consists of an rf oscillator capable of being tuned over a wide frequency range, a visual indicator to show when energy is being absorbed from the oscillator tank circuit, and a source of power. Practically all grid-dip meters utilize an electron tube in the oscillator circuit with a low-range milliammeter or microammeter connected to read grid current. Their most common use is to determine the resonant frequency of de-energized tuned circuits. The grid-dip meter described in this article utilizes a high-frequency drift transistor (RCA type 2N247 or 2N384) in the oscillator circuit, a semiconductor diode (RCA type 1N34-A) and microammeter as an rf indicator, and a $1\frac{1}{2}$ volt miniature battery, such as the RCA-VS304, as the source of power. Oscillation in the common-base oscillator circuit is sustained by the feedback capacitor C_3 (see Figure 1). Rf voltage in the emitter-base circuit is capacitively coupled through C_1 to a semiconductor diode, and the rectified output can be read on the dc microammeter M. When power is absorbed from

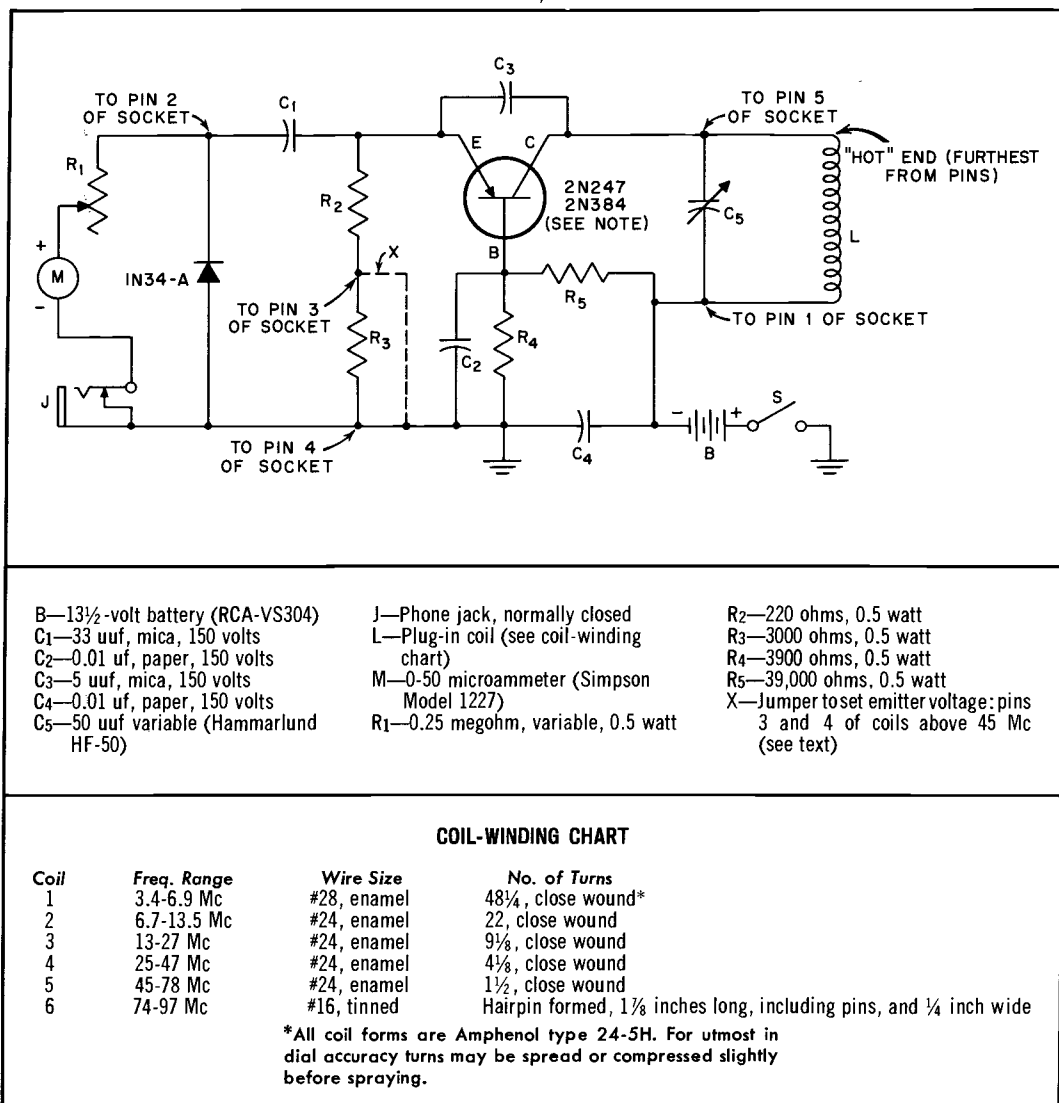

Figure 1: Schematic diagram, parts list, and coil table. Note that the 2N384 is for use at frequencies up through 100 Mc; the 2N247 for use at frequencies up through 50 Mc (including 6-meter band). The interlead shield is grounded.

the tuned circuit, L and C₅, rf feedback to the emitter is reduced and the microammeter shows a decreased reading. Some damping of the indicator circuit is provided by the emitter resistors R₂ and R₃.

Three desirable features for such an instrument are compactness, portability, and a self-contained power source. The low power drain and small size of the transistor used has enabled the instrument described in this article to have all of these features.

Measuring only 2⅞ by 3 by 5¼ inches, this grid-dip meter can be held and operated with one hand. It is compact and, therefore, capable of being closely coupled to tuned

circuits in compactly designed equipment. It is completely portable and, being battery-operated, can be used anywhere. Because there is no heater to warm up, the instrument is instant-starting. Also due to the absence of heat, its frequency stability is excellent. Total power consumption is about 25 milliwatts! The instrument is relatively shock-resistant, and requires little maintenance. The transistor itself may never require replacement. The battery drain is so small that, with normal use, battery life for all practical purposes is "shelf life." Equally important, the instrument is very sensitive and accurate.

The RCA drift transistors, 2N247 and

2N384, are ideal for use in this instrument because they are designed specially for high-frequency applications. The 2N384 produces useful output in the circuit shown in Figure 1 at frequencies up through 100 megacycles. The 2N247 produces useful output in this same circuit at frequencies up through 50 Mc. These transistors may be used interchangeably in this instrument without circuit changes of any kind. The dial calibration remains accurate for either transistor.

Construction

The entire instrument is housed in a "Flexi-Mount" case measuring $2\frac{1}{2}$ by 3 by $5\frac{1}{4}$ inches. All parts are mounted in the upper section of the case as shown in the photographs, Figures 2 and 3. It is suggested that the case be drilled and cut in the following steps to insure proper fitting of the parts. Cut the meter mounting hole first. A $2\frac{3}{8}$ -inch square meter, such as the Simpson Model No. 1227, is recommended. The meter hole should be cut $\frac{1}{8}$ inch in from one end of the case and the meter temporarily mounted. Cut a piece of $\frac{3}{16}$ -inch polystyrene about $1\frac{1}{8}$ inches wide and $2\frac{1}{4}$ inches long and drill two $\frac{1}{4}$ -inch holes at one end to fit over the meter binding posts. This strip will serve as a mounting board for the tuning capacitor and other small parts. Next, cut two discs from $\frac{1}{16}$ -inch-thick polystyrene for the dial. Sandwich the printed dial, shown at right, between the discs, and fasten the discs by means of two small screws to a bushing having a $\frac{1}{4}$ -inch diameter hole. Drill and tap the bushing to receive these screws. Make two cuts in the front right-hand side of the case far enough apart to allow the tuning dial to protrude about $\frac{1}{4}$ inch. Bend the cut-out piece under and lay the dial in place. A similar cutout is also required for the cover section of the case. Bolt the tuning capacitor to its mounting strip so that its shaft engages the dial bushing, as shown in Figure 3. Next, cut a window in the top of the case for use in viewing the dial. A piece of thin wire may be fastened across the dial window to provide a hairline.

Mount the coil socket so that the rotor connection of the tuning capacitor contacts pin No. 1 of the socket, as shown in Figure 3. The meter control, phone jack, and switch are mounted at the rear of the case. Bend a $\frac{3}{4}$ -inch-wide strip of metal to hold the battery as shown in Figure 2. Fasten one end of this strip to the front of the case and the other end to one of the meter mounting screws. A portion of the capacitor mounting strip should be cut away to make room for the battery. A folded strip of metal at the front of the case serves as a spring to hold the battery in place. The cover section of the "Flexi-Mount" box helps to secure the battery when the case is sealed.

Check to see that all parts fit into place and that the dial moves freely. Some minor

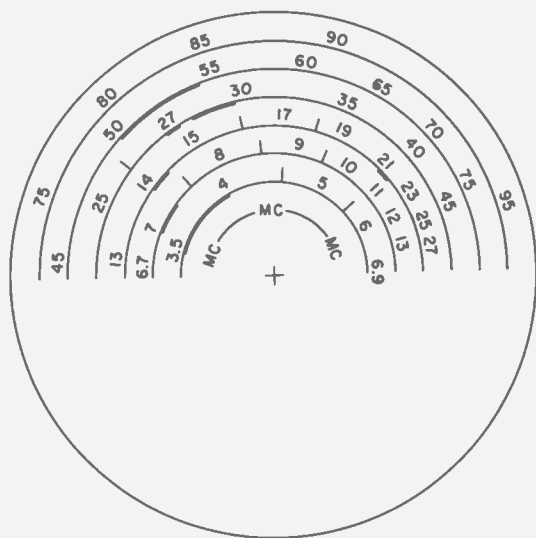

Here is the dial referred to in the text at left. Trim along the outer circumference of this dial and sandwich it between two plastic discs of the same diameter.

adjustments may be required. Use of washers and some judicious filing to alter the positions of the parts may be helpful.

Wiring: The instrument is now ready for wiring. It is suggested that parts be located as shown in the photographs. Wiring is not critical; however, for dial accuracy, the two heavy leads connecting the tuning capacitor and coil socket should be kept short, as shown in the photographs. The polystyrene strip supporting the tuning capacitor may be used as a mounting board and drilled to accept leads from small parts including those of the transistor.

Coils: Coils are constructed according to the table shown in Figure 1. Pins No. 3 and No. 4 on each of the two high-frequency coils

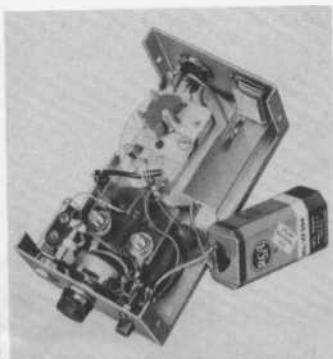

Figure 2: Bottom oblique right inside view of grid-dip meter showing parts layout. Battery has been removed to show battery mounting platform.

(45 to 78 and 74 to 97 Mc) should be connected with a jumper to short out resistor R_3 . This connection automatically sets the emitter voltage at the proper value when either of the high-frequency coils is used. Pin No. 5 of the coil form should be used for the end of the coil furthest from the pins. This arrangement puts the "hot" end of the coil in the best operation position. Following initial tests and adjustments, the coils should be sprayed lightly with a clear plastic spray. A dot of paint at the end of each coil form, with matching dots on the case next to the dial window, provides color coding to indicate frequency range of the coil in use.

Initial Tests and Adjustments: Check the wiring carefully before installing the 13½-volt battery. Two small pins like those on the coil forms may be used for making connection with the battery plug-in terminals. Insert one of the plug-in coils, switch the instrument on, and adjust the meter control for a mid-scale meter reading. The meter should indicate a sharp dip when the end of the coil is touched.

To set the dial, tune the instrument to one of the amateur bands and zero-beat its signal in the receiver. Loosen the set-screw on the tuning dial and adjust the dial to the receiver

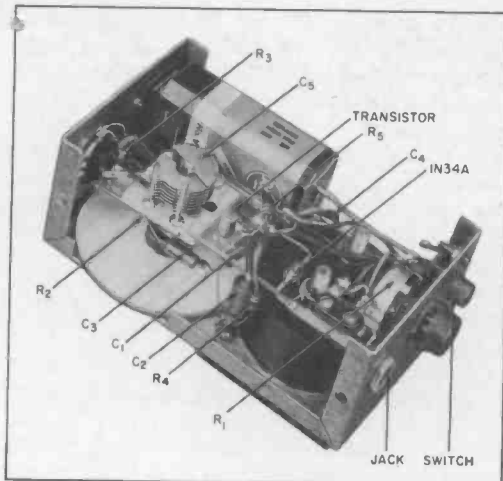

Figure 3: Bottom oblique left inside view of grid-dip meter showing parts layout and tuning capacitor mounting. Note cutout necessary to clear tuning dial.

frequency. Tighten the set screw and check the other coils for accuracy. Increased dial accuracy may be obtained by spreading or compressing the turns on the coils. If the coils have been properly wound and the tuning capacitor mounted as described previously, dial accuracy approaches $\pm 2\%$.

Devices and arrangements shown or described herein may use patents of RCA or others. Information contained herein is furnished without responsibility by RCA for its use and without prejudice to RCA's patent rights.



IF IT'S ELECTRONICS
CALL BARBEY'S FIRST

5/29/66 P.L.S.R.



From your local
RCA distributor,
headquarters for
RCA receiving
and power tubes.

RCA HAM TIPS
is published by the
RCA Electron Tube
Division, Harrison,
N. J. It is available
free of charge from
RCA distributors.

GEORGE D. BARBEY CO., INC.
Reading
Lancaster
Pottstown
Lebanon



Harvey Slovik, Editor
Robert Leedy, W2PMP
Technical Editor

FORM 3547 REQUESTED