

RCA ENGINEER



RCA

Vol. 13 - No. 5 Feb. - Mar. 1966

Staff

W. O. HadlockEditor
J. C. PhillipsAssistant Editor
Miss M. V. DalyEditorial Secretary
J. L. ParvinArt Director

Consulting Editors

C. A. Meyer, Technical Publications
Administrator,
Electronic Components and Devices
C. W. Sall, Technical Publications
Administrator, RCA Laboratories
G. Smoliar, Technical Publications
Administrator, Electronic Data Processing
F. D. Whitmore, Technical Publications
Administrator, Communications Systems
Division

Editorial Advisory Board

A. D. Beard, Chief Engineer
Electronic Data Processing
E. D. Becken, Vice President and
Chief Engineer, RCA Communications, Inc.
J. J. Brant, Staff Vice President,
Personnel Administration
C. C. Foster, Mgr., RCA REVIEW
M. G. Gander, Mgr., Consumer Product
Administration, RCA Service Co.
Dr. A. M. Glover, Division Vice President
Technical Programs,
Electronic Components and Devices
C. A. Gunther, Division Vice President,
Technical Programs, DEP and EDP
E. C. Hughes, Administrator, Technical
Committee Liaison,
Electronic Components and Devices
W. R. Isom, Chief Engineer,
RCA Victor Record Division
E. O. Johnson, Mgr., Engineering,
Technical Programs,
Electronic Components and Devices
G. A. Kiessling, Manager Product Engineering
Professional Development
L. R. Kirkwood, Chief Engineer,
RCA Victor Home Instruments Division
W. C. Morrison, Staff Vice President,
Product Engineering
D. Shore, Chief Defense Engineering,
DEP Defense Engineering
J. L. Wilson, Director, Engineering
National Broadcasting Co., Inc.

OUR COVER

An engineering laboratory provides the background for this cover; the engineers are (left to right) W. Culp, N. Mortensen, F. Papouschek, D. Garris, E. Mahland, and R. Short—all of Broadcast and Communications Products Division Engineering, Meadow Lands, Pa. Arranged on both the front and back covers are a few of the hundreds of products produced by this division. On the front cover (clockwise from upper left) are the TR-70 TV tape recorder, the PK-330 studio vidicon camera, the super-fleetfone two-way radio, and the EMU-4 electron microscope. On the workbench in front of Messrs. Mahland and Short is the RCA-1600 16-mm projector. On the back cover (clockwise from top) are the AR-8714C fixed-loop radio direction finder, the TK-42 color TV camera, and the CW-60 microwave antenna.

Market Influence on Product Design

In the last decade, technical concepts have broadened rapidly; new components have proliferated; and product sophistication has increased immeasurably.

New requirements generate a response of new products or added complexities of design. New opportunities provide markets for more new products and services. The spiral appears to ever widen and always to accelerate. But through all this runs the economics of the market place: cost, cost effectiveness, reliability, availability, quality of performance, serviceability, and that great stimulus of our free enterprise system—*Competition!* Are there any who have not felt its threat or redoubled efforts to meet its challenge? Or on occasions felt the bitter sting of defeat produce the desire to surpass?

Viewed broadly our Company has the resources, the market coverage, the distribution system, and the customer recognition requisite for continuing success. Much then, depends on the product design; its cost, timeliness, flexibility, reliability, state of the art technology, and technical integrity. To a great extent all of these factors rest with the engineers—a heavy responsibility indeed, but one in which success is crowned with a great sense of personal achievement.

*Barton Kreuzer, Division Vice President and General Manager,
Broadcast and Communications Products Division*



Contents

	The Engineer and the Corporation: Task-Oriented Value Engineering—Key to Systematic Value Control	K. M. Stoll	2
	Communication with Man on the Move	G. S. Kaplan	6
	The World's Most Powerful Television Transmitter	D. R. Musson	10
	Mobile Communications Base Stations	F. Papouschek, A. N. Mortensen	16
	Single-Sideband Equipment Design—Developing the STR-150 and SBA-1K	E. W. Mahland	20
	Planning 13-GHz TV Relay Systems	E. J. Forbes	26
	TVM-6/13 Microwave Relay Equipment	J. B. Bullock	30
	Improving Automatic Sensitivity Performance in Color TV Film Cameras	R. R. Brooks	35
	RCA's TA-19 Video Processor	L. J. Baun	38
PAPERS	Spectrum Analysis of Magnetic Video Recorder FM System	K. Sadashige, J. B. Van Anda	42
	Correction of Hue and Saturation Errors in TV Tape Recording	J. R. West	47
	Advanced TV Program Switching Equipment	J. M. Walter, F. D. Rando, C. R. Monroe	52
	Audio Distribution by Carrier Methods	R. W. Jorgenson	57
	New Television Audio Console	H. Krochmal	60
	Automatic Audio Signal Processing	R. F. Abt	63
	The RCA-1600: An Improved 16-MM Sound Motion Picture Projector	L. J. Anderson, R. D. Short	68
	Planning for Communications Satellite Research and Development	S. W. Spaulding	71
	A Novel Interchangeable Magazine TV Slide Projector	W. F. Fisher, B. F. Floden	74
	Spot Navigation Satellite System	J. Breckman, J. D. Barnla	79
	A Simplified Method of Conducting A Dual Random Vibration Integrated System Test	J. G. Colt	84
	NOTES	An Analysis of Economic System Subdivision	R. J. Treadwell
Pulse Amplification and Shaping with the Versatile IC—CA3035		W. R. Walters	87
DEPARTMENTS	Reprints of RCA Engineer Articles		88
	Pen and Podium—A Subject-Author Index to Recent RCA Technical Papers		89
	Patents Granted		92
	Professional Activities—Dates and Deadlines		92
	Engineering News and Highlights		93

A technical journal published by RCA Product Engineering 2-8, Camden, N. J.

- To disseminate to RCA engineers technical information of professional value
- To publish in an appropriate manner important technical developments at RCA, and the role of the engineer
- To serve as a medium of interchange of technical information between various groups at RCA
- To create a community of engineering interest within the company by stressing the interrelated nature of all technical contributions
- To help publicize engineering achievements in a manner that will promote the interests and reputation of RCA in the engineering field
- To provide a convenient means by which the RCA engineer may review his professional work before associates and engineering management
- To announce outstanding and unusual achievements of RCA engineers in a manner most likely to enhance their prestige and professional status.

This paper defines a task-oriented application of value engineering that has been actively practiced in an environment of system complexity, stringent schedules, and customized production. Its effectiveness in individual-task value improvement led to investigation of a wider application to the full spectrum of program tasks. The concept of systematic value control that grew out of this effort has been applied at successive stages of a major space program with worthwhile results. Improved performance, reflecting the benefits of this effort, is demonstrated. Guidelines to successful application are given, including attention to significant program-management practices, skill-center motivation, effective promotion, and recommended organizational relationships.

The Engineer and the Corporation

TASK-ORIENTED

VALUE ENGINEERING

Key to Systematic Value Control

K. M. STOLL

*Value Systems and Control
Astro-Electronics Division, Princeton, N.J.*

PEOPLE were concerned about value long before value engineering. Value improvement is performed directly or indirectly by every discipline in an industrial organization, as necessity demands. Value engineering is a practice for advancing that function (the improving of value) from the level of random effort to that of organized method. The present practices are not, however, a universal approach that can be used indiscriminately with equal effectiveness.

The principal obstacle in promoting value engineering is the wide divergence of opinion that has developed around the subject. There are enthusiastic "cultists" who consider it an industrial panacea and equally determined skeptics who see it as a "gimmick" program. Actually, its success is by no means a measure of value engineering's real capabilities, and unsuccessful experience has not necessarily established its limitations. It must be remembered that value engineering is a tool, and as such is fully effective only when used correctly. Maximum results will be obtained only when value engineering effort is correctly oriented for each unique environment.

THE CONVENTIONAL APPROACH

Design-Oriented

The value engineering customarily practiced is design-oriented. Its origin as an engineering discipline was in an environment of high-volume product-lines. Its more significant contributions in aerospace companies have also been associated with substantial unit quantities of a design or device. The basic questions upon which the conventional job plan is based are design-oriented:

Final manuscript received January 17, 1967.

VALUE ENGINEERING IS A TOOL

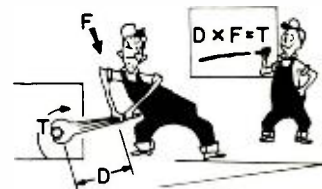

Value engineering is a tool, and as such is fully effective only when used correctly.

CORRECT USAGE IS IMPORTANT

*What does it do? (What is the function?)
What does it cost?
What else would do?
What would that cost?*

This is the widely accepted methodology for exploring the function/cost relationships in electrical or mechanical designs. Functions are defined for each design element, all direct or related costs are identified for each, the unnecessary functions (and their costs) are eliminated, and creative measures are devised with which to accomplish the necessary functions at lowest cost.

Limitations

Design-oriented value engineering has been particularly frustrating for most aerospace companies. It is a second-look technique, and complex military or aerospace systems programs afford very few opportunities for a planned "second-look" at design entities at any level. More often than not, by the time that designs are defined sufficiently to permit value improvement measures, program schedules simply cannot accommodate either the value engineering effort or the changes that may result. Obviously, both the customer and the contractor would like to improve value. Unless offsetting schedule advantages are clearly discernible, however, they cannot afford to stop program operations for the necessary investigation and implementation.

System complexity is an equally real constraint. It is usually easy to define part functions, identify final costs, and weigh the comparative merits of possible improvements for standard product-lines. A complex systems program, however, is a totally different ball-game. For example, the practical difficulties in identifying the impact of discrete black-box functions on system requirements will be readily apparent. Similar difficulty is experienced in assessing the many related cost effects. This complexity makes conventional value engineering so costly and time-consuming that it may be warranted on some systems programs only where potential improvements are very great, and only if schedules will allow.

RE-ORIENTING THE APPROACH

A re-oriented approach has been found that is effective in overcoming the foregoing limitations (and in disclosing wholly new horizons). The new approach applies value engineering directly to program tasks. Systems programs are inherently task-oriented. The structure of a typical aerospace or military systems program defines a multiplicity of program tasks to be performed in developing and/or producing a limited number

of contract end-items. The cost structure of such programs identifies the known or estimated cost of individual task performance. The following are representative program tasks:

Subsystem Tasks (each subsystem)

- Design
- Prototype fabrication and assembly
- Prototype qualification
- Flight fabrication and assembly
- Flight acceptance test

System Tasks

- Design
- Integration and test mechanical/electrical and prototype/flight

Management Tasks

- Cost and schedule control
- Configuration control
- Project management

Support Tasks

- Reliability engineering
- Material quality control
- Product quality control
- Publications

Depending on the nature of the program, work authorizations (shop orders) may be assigned at these levels, or at such lower (black-box, subassembly) levels as are necessary.

Similar Job Plan

The new approach employs the same basic job plan, substituting task scope for part function. The significant difference is in the directness of application. In the conventional, design-oriented value engineering exploration of function/cost relationships, active consideration of alternatives ("what else would do?") always demands an answer to the more basic "what is required?" Task-oriented value engineering addresses itself directly to that requirement/cost relationship. The basic job-plan questions, which are task-oriented, can be expanded as follows:

What is the scope of the task?

- What are the elements of the task (What is to be done)?
- Which elements are contractual?
- Which elements are based on:
 - Past practices—How valid are they for this program?
 - Internal standards—How valid are they for this program?
 - Assumptions—Can they be substantiated?
 - Understandings—From whom?

What will it cost?

- Known—From what source?
- Estimates—How related to scope?

What else would do?

- What is required contractually, or to satisfy minimum company standards for reliable performance?

What would that cost?

- What is unnecessary?
- What can be done otherwise (to meet requirements at lowest cost)?

Each of these questions can be rephrased and directed to suit the specific task under scrutiny. In all cases, the objective is a searching inquiry into what is to be done—the understandings, interpretations, or assumptions that define the task and substantiate the costs. Program requirements may be defined contractually, invoked by document references, or they may represent application of company standards or practices. Task-oriented value engineering ferrets out the facts of these requirements, so that appropriate action can be taken to produce value improvement.

The validity of applying value improvement effort directly to the requirement/cost relationships that have already been

defined by the proposal and the negotiations is inescapable. Improvement of those relationships is an iterative process that spans the full period from inception of the proposal to completion of contract performance. Task-oriented value engineering is ideally suited to that process, with significant advantages over the conventional approach.

Comprehensive Coverage

Foremost among the many advantages of the new approach is the comprehensive program coverage it affords. Design-oriented techniques have always had a limited effect, since there are many requirements in any systems program that are not design-related. In a program calling for delivery of as few as four systems, with a contract value of several million dollars, there will often be no more than 20 to 25% of program cost related to actual hardware, and little of that amount will be in an easily defined, direct relationship. If by some combination of fortunate circumstances every design area could be the subject of value engineering, from 75 to 80% of the program costs would still be outside the scope of the effort. Such programs will, on the other hand, usually define as many as 150 separate program tasks, each of which can benefit from task-oriented value engineering. This is an extremely significant advantage. The 75 to 80% of the costs in a typical systems program that are not design-related are as fertile a field for value improvement as any design area. Moreover, it has been demonstrated that substantial design improvements can be instigated through value engineering of other than design areas. Testing tasks, in particular, have been such an area. Value engineering examination of testing tasks has drawn attention to potential design improvements that easily could have eluded design-oriented scrutiny.

Flexibility

Possibly the most evident advantage of the task-oriented approach is greater flexibility. Defining part functions and determining the total cost for each is a time-consuming aspect of design-related value engineering. It entails participation of the full inter-discipline group in information search and in preparation for the brainstorming that will be used to develop possible alternatives. Most of this information must be developed individually for each design entity.

A task-oriented effort does not require the involvement of the entire inter-discipline group during all stages. Because the basis for the task-oriented approach is the requirements/cost definition which already exists, much of the preparation for the creative effort can be performed in advance by the value engineering activity. The larger group need not become involved until the creative stage. There is a wide commonality of program requirements that affects every task. Once these requirements have been well defined it becomes increasingly easy to uncover the limited number of requirements unique to specific tasks. Many tasks can be fully prepared

Fig. 1—The task-element "hidden baseline".

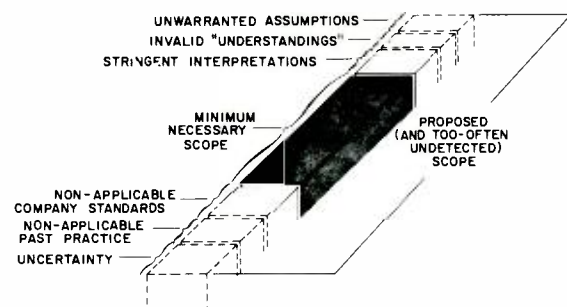

for quick action by the larger group, with the degree of involvement determined by the improvement potential revealed during the initial preparation.

SYSTEMATIC VALUE CONTROL

There are far wider implications in the task-oriented approach than may be evident in the advantages discussed above. The objective of value engineering—to eliminate or modify anything (in the task under scrutiny) contributing to cost but not necessary for meeting requirements—is also the management objective for any program as a whole. The inference that can be drawn is that systematic control of value could be accomplished by planned use of value engineering on every program task. In effect, this is true. Program value can be regulated—the unnecessary costs removed and improvements developed—through planned use of this type of value engineering.

The important fact to recognize in planning the use of value engineering is that there is only a single program stage at which fully effective value control can be initiated. Control can be lost at any point and a degree of control can, with additional effort, be reestablished at various stages. The only stage, however, at which to define the baselines from which to bring value under control is during the generating of the program proposal.

Proposal Stage Value Engineering

The generally recognized baselines of a proposal are the contract end-items that are defined, the estimated costs of producing them in accord with specified customer requirements, and the program schedules for delivery. The proposal, actually, is a composite of these baselines and the many others that for all practical purposes remain hidden. Value control is possible only when these hidden baselines (Fig. 1) are carefully identified as frames of reference for subsequent program actions.

Uncertainties in interpretation of customer requirements are frequently compounded by poor communication to different levels of the proposal effort. As a result, the proposal usually includes not only that which was required but much that was assumed to be wanted. Necessary items are often overlooked. Practices followed on a developmental contract are often perpetuated in follow-on proposals even though not actually required. Cost estimates reflect “understandings” that are in fact assumptions, and internal standards intended for specific application are referenced where no valid need exists. Somewhere in this welter of confusion (far more the rule than the exception in the pressure of systems program proposal effort) lies the scope on which the cost proposal was based. Control must begin here.

The value engineering activity can fill two functions at this stage. The most essential function is to track the proposal effort. Nothing will aid proposal management more than the elimination of proposal uncertainties. The cost-effectiveness of a proposal can be influenced in large degree by establishing the validity of the proposed scopes of work at this stage. With this degree of spade-work accomplished, a proposal represents not just *what we propose to build for a specified amount*, but a clear understanding of the *specific tasks required with valid costs* estimated for each. The cost effectiveness of a proposal, however, depends on more than can be provided by this primary effort. If a company is to be competitive in today's aerospace environment, ingenuity and inventiveness must be brought to bear on its proposals. Ways must be found to accomplish the required scope of work at lowest cost.

Another important function of value activity comes into

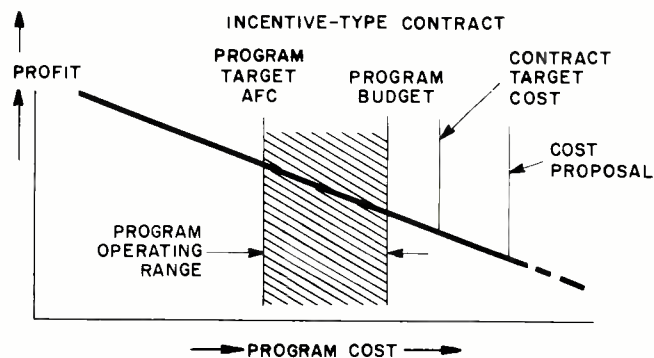

Fig. 2—It has been demonstrated that an improved profit position such as this is attainable with systematic value control.

play at the proposal stage. The investigations for weeding out unnecessary costs will have highlighted areas of significant potential improvement. The selective use of value engineering task-groups to explore these areas can contribute strongly to lower cost proposals.

Negotiation Support

Significant enhancement of value control can result from use of the value engineering activity, before and during contract negotiations. The requirement that the proposal be fully responsive does not preclude consideration of alternatives. More often than not, customer budget constraints will make this a negotiation necessity. Selective use of value engineering in the pre-negotiation period can provide the negotiators with specific details (and assessment of the cost and schedule impact) of possible task scope changes.

Using pre-negotiation value engineering to develop possible scope changes has a special importance. The Department of Defense is asking its contractors to submit Value Engineering Change Proposals (VECP's) to tell them where value could be improved by changes in their requirements. They ask this help and include a contractual clause for sharing the benefits with the contractor. There is nothing in negotiated government-agency contracting, however, that would limit doing the spadework for VECP's well in advance of contract award. In fact, in the customer's concept of control of value, this is expected. His objective is to eliminate unnecessary costs. The negotiating table is where he intends to identify and eliminate some; the incentive sharing clause in the contract is where he hopes to come upon others. Value engineering effort prior to negotiations is a logical preparation for both stages.

There is another feature of pre-negotiations value control that should not be overlooked. As in the proposal stage, it is beneficial to follow the requirements/cost changes. If the baselines initially identified are carefully updated, through the prenegotiation period and again upon completion of negotiations, program management is in a favorable position for rapid authorization of tasks and determination of budgets.

Contract Performance

Value control activity in the period of contract performance is governed by the degree of control initiated originally and the extent to which it has been maintained. Cost and requirement baselines that have not been adequately defined in the proposal effort, or not updated through later stages, are difficult to re-establish after award. Task-oriented value engineering can and often must be used to *reestablish* value control, but it is a difficult application.

Value engineering for *maintenance* of value control, on the other hand, is the ideal application, as all baselines will have been well-defined with a clear history of successive change. Tasks can be re-examined—brainstormed anew and new influences brought to bear to tap additional resources of in-

ventiveness. There may be any of a number of goals at this stage: to overcome a negotiation loss, to provide for program operations contingencies, to take full advantage of a cost incentive provision in the contract, to improve schedules, or to exploit the VECP potential of the program to the full. In any event, the objectives are all profit-related and the way to them will have been made easy by the value controls previously established.

GUIDELINES TO SUCCESSFUL PRACTICE

Promotion

Whether value engineering is being initially introduced into an organization or a re-introduction is taking place, careful planning of the promotional effort is extremely important. Value engineering must not risk falling victim to its own promotional practices. An aura of gimmickry can result from the widespread use of contrived situations as training examples, and a superficial indoctrination of many people can foster a considerable misunderstanding of the discipline. The most important guideline is that a value-conscious organization is attained by first developing adequate knowledge and understanding of the discipline among those most directly interested in its benefits—i.e., among management. There is no necessity to exhort all and sundry to general use of a technique that is intended for carefully selected application as a part of program management strategy. The most useful promotion possible is a quiet campaign to persuade program (or product-line) managers of the importance of a planned use of task-oriented value engineering.

Formal training in value engineering methodology, except for those who staff the activity, is less useful than active participation in value engineering task-groups dealing with actual problems. [The term, value engineering task-group, is applied to the inter-discipline group that is assembled to perform the value engineering effort. These are the people who gather requirements/cost information and use it to develop value improvements in the specific task under scrutiny.] Task-group effort of this nature amounts to a form of on-the-job training, and once the program gets under way, it consists of little more than introducing task-group newcomers to the methodology. The indirect benefits are also considerably greater than for conventional workshop training, because these actual-practice applications can be related to other current problems.

Reporting Practices

Another aspect of value engineering practice that is closely related to promotion is the reporting of value engineering activity. Similar criteria apply here. There is no reason for reporting value engineering activity except in quarters where the report serves a purpose. The results of value engineering task-group effort are recommendations and data on which management decisions can be based. In the production of complex systems, there will be constraints unique to each program. It can be useful, and in some instances absolutely necessary, for task-group findings to be reported only to program management until decisions have been reached or possibly even until they are implemented. The value engineering activity must look upon program management as an "employer" who directs the distribution of such information for his purposes.

When final results of task-group effort have been verified by program management, the final report should be shared with the task-group participants and whomever else program management designates. Summary reports of value engineering accomplishment for any period should include only verified results, and distribution should be determined by the management functions requesting the report.

Motivation

Motivating the principals—the skill-group people whose creative and inventive talents provide the improvements—is a subject that requires separate treatment for adequate coverage. [The term skill-group identifies the group authorized to perform a task, i.e., those supplying program management with the specific skills, as Design Engineering (of various types), Fabrication and Assembly, Environmental Test, Materials Quality Control, etc.] For the purposes of this discussion, however, one important aspect of motivation will be presented.

When skill-group people are asked to develop improvements for a task, the budget reductions that result may include their own. Under certain workloads this may be palatable, but, in general, people do not enter into such an effort with great eagerness.

An effective solution is demonstrated by Fig. 2. This shows a typical incentive contract in which reduction of program cost yields increased profits to the contractor. The target AFC (anticipated final cost) position is the total of the success-schedule, fail-free estimates asked of the skill-groups for the respective tasks. The larger budget position includes their estimate of task contingency requirements. Task performance at any point below the budget position represents a skill-group contribution of that amount to added company profit.

This practice of defining a targeted underrun for each task makes it possible to give recognition for good task performance. At the same time, it provides program management with an early-warning line (the target AFC) by which to identify incipient cost problems. As a motivational tool for skill-groups, it has proven highly successful. On programs where this approach has been used, it has become a real point of pride to perform within the targeted underrun, i.e., below task budget.

CONCLUSION

The value engineering concept presented is innovative. It builds on the foundation of already proven methodology and reorients the discipline for the aerospace producers' unique environment. More importantly, it significantly widens the horizons of program management. With planned use of value engineering at successive program stages, the principles of baseline management can be implemented at the far more significant task-element level. With this approach integrated into management strategy, the advance is from random solution of value problems to systematic control of value.

K. M. STOLL has had 30 years of industrial experience, including 20 years in electro-mechanical design and process mechanization. He holds six U.S. patents for electronic products and production equipment. He joined RCA in 1960 as Standardization Specialist with the (then) Industrial Electronics Products, where he developed a comprehensive program of mechanical component and manufacturing workmanship standards. He was transferred to the Astro-Electronics Division in 1963 as a member of its Technical Advisory Staff. In 1964, his assignment was broadened to include the development of a methodized value improvement capability within the division. Under his direction, value engineering task-groups have achieved significant results in improving the cost of performance on major systems contracts. In September 1965, he was named Administrator, Value Systems and Control. Professional activities include membership in the Society of American Value Engineers, the Standards Engineers Society and the American Society of Tool and Manufacturing Engineers.



COMMUNICATION WITH MAN ON THE MOVE

A woman stranded alone in a disabled automobile on a stormy night; a man noticing three suspicious characters following him along a city street; and a police officer at the scene of a potential riot all share one common characteristic. They are apprehensive yes, but even more, they all have need of a personal communication system. Of course, the necessity of a personal communication system is certainly not restricted to those who are endangered. This need also extends to many other, perhaps less dramatic but nevertheless important applications. For many doctors or busy executives, a personal communication system is not a luxury but a necessity. Those who might consider such a communication capability a luxury at the present should be reminded that the luxuries of the present are the necessities of the future. This article will present some ideas concerning the present and future necessity—communication, by and with, man on the move.

GERALD S. KAPLAN

*Communications Research Laboratory
RCA Laboratories, Princeton, N. J.*

FOR THIS ARTICLE the term, "man on the move," essentially refers to man not fixed in a given location (home or office). This includes man while traveling in conventional transit facilities such as car or train but is also extended to include even such outmoded means of transportation as walking.

One of the first questions to be answered in providing the additional communications capability required by man on the move is what band of frequencies can be used for this service? Initial investigation quickly reveals that the frequency bands presently allocated for mobile communication service are marginally adequate, and in many situations inadequate, for the needs of *present* mobile communications requirements. The Federal Communication Commission (FCC) has divided the frequency bands allocated to mobile radio into channels 15 kHz, 30 kHz, or 50 kHz wide (depending upon frequency). In urban areas especially, these channels are utilized to saturation and beyond. Over a thousand police or taxi transmitters may be assigned to a single channel in large urban areas such as New York or Los Angeles. Since less than 5 percent of U.S. cars are equipped with radio transmitters, and given the natural increase in the (car and

people) population, presently used mobile frequencies will be inadequate for the task of providing future communication capability with every man on the move.

More efficient use of the spectrum (such as narrower channels) or quasi-orthogonal signalling schemes (such as Random Access Discrete Address) would, if adopted, perhaps accommodate some additional users but the bulk of the additional information bandwidth required will have to be achieved at frequencies other than those presently used.

Man has constantly gazed upward towards the heavens for consolation and solution to his many earthly problems. For our problem of finding available spectrum it is not inappropriate to gaze upward in the frequency spectrum. Of course if we gaze too high, we may wind up with a stiff neck but there are recent research laboratory discoveries, such as the Gunn effect or Avalanche Transit Time diodes, which promise to soothe these aches.

Accordingly we necessarily turn our attention to portions of the spectrum not previously considered useful for mobile radio systems in hopes of finding the necessary bandwidth to satisfy the needs of communication with man on the move. Frequencies above 10 GHz have two

very important features which make them extremely promising for providing the communication capability in an urban area. First of all large bandwidths are more easily achieved at these higher frequencies and, perhaps even more important, these frequencies are still relatively uncongested.

The next section discusses how one might provide a mobile communications capability when the ever increasing demands for such a service have exhausted the presently usable portion of the radio spectrum.

A MOBILE COMMUNICATIONS NETWORK

The initial discussion is restricted to providing such a capability within the traditional urban center such as New York, San Francisco, etc. So given the above environment, how do we communicate with man on the move? This ubiquitous man is found everywhere and anywhere within the city. Since the frequencies we are forced to consider will not penetrate inside buildings (where a telephone can serve as an adequate communication aid), the system we now examine is further restricted to providing mobile communication where it is really necessary—on the streets and highways of the city.

At operating frequencies above 10 GHz, communication is generally restricted to line of sight and so a mobile receiver should be in view of a transmitter and vice versa.

One way of accomplishing this in a large city is shown in Fig. 1. A grid or net is "placed" over the city with fixed transmitters-receivers mounted on buildings or traffic lights or utility poles, etc. in such a way that the city streets would be completely illuminated with RF energy. The mobile transmitter-receivers are mounted in automobiles, trucks, taxis or they could even be hand-held. Notice that the maximum distance between the fixed units is a function of geometry of the city (since line of sight must be maintained) and may not be limited by power consideration.

The fixed transmitter units must now be connected with a relay net which can transfer information from one part of the city to another. The actual interconnecting links of the relay net could be cables such as those used in CATV systems, or a radio system utilizing millimeter or optical frequencies, or possibly a combination of different methods. However, we must have a relay net for operation of this, or any other system employing line-of-sight frequencies.

An additional requirement to make the system operative is a communications control center which would handle rout-

Fig. 1—Streets are illuminated with RF energy.

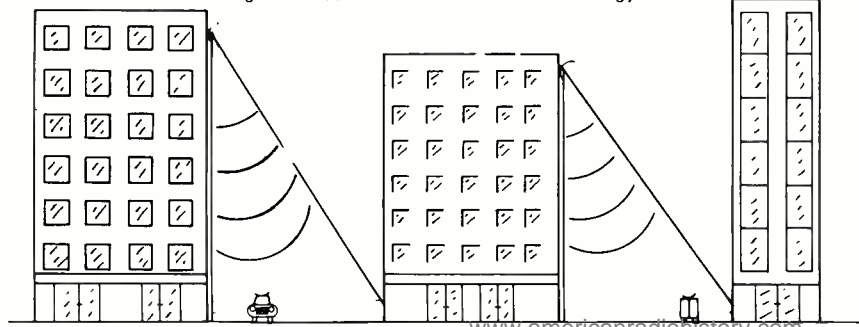

ing of the signals to the proper destination. To compensate for signal attenuation in the relay net, repeaters must be used with the gain of the repeaters just compensating for the loss in the relay net. Too much gain will saturate the system after a few repeater stages while too little gain will result in the relayed signal falling below detectable levels.

For many reasons (reliability, economy, noise immunity, etc.) it is desirable to keep the total number of repeaters through which a signal must pass as small as possible. Obviously we would not want to connect all the fixed transmitter-receivers in series since the total path length will be very long. On the other hand, providing a direct connection from each fixed transmitter unit to the communications center would require an excessive amount of cable. But by having a net consisting of a main part (trunk line) which routes the signal to a general area and a secondary part (branch line) which delivers the signal to its final destination, the number of repeaters that compose a given path is greatly reduced and the overall system is more efficient. Fig. 2 illustrates how the relay net might be set up.

Assume a dispatcher of a fleet of taxis wants to communicate with one of his drivers. The dispatcher first contacts his communications center either by regular phone lines, or since he requires use of the communication system quite often, a special line could be installed from his location directly to the communications central. The central automatically switches the message into the relay net, and after passing through the trunk and branch lines, the message is broadcast from the fixed building or pole-mounted transmitter-receiver units into the streets of the city, where the driver receives his message. For communication from the driver to the dispatcher, the system works in reverse. The driver broadcasts his reply, it is received by the building mounted units, appropriately processed and placed on the net. The returning signal, which does not have to go through the entire net, is sent directly back to the communications center. At the center the signal is then sent directly to the taxi dispatcher.

There are many questions which must be answered before a practical system can be implemented. Questions as to power required in the individual transmitters, the type of modulation to be used for the communications link between relay net and the mobile unit in the street, the actual topology of the net, modulation employed to transmit signals along the relay net, etc. are all interrelated in a complex manner and before an op-

timum choice is made, systems analysis and cost tradeoffs must be performed.

There are other, non-technical but equally important, questions which must be given consideration:

Who will control and be responsible for the communication system?

Should the city government actually be the owner of the system and use it primarily for its own needs with private companies and individuals also allowed use of the communications system?

After all, the relay net will be placed along city streets and property. However, the public utilities, which are privately owned and operated, although regulated by government agencies, also make use of city streets and property for cables, pipelines, etc. The formation of a new utility, a mobile communications utility, might be a means of insuring proper operation of the new system. Or the city may grant a franchise to a private company to install and operate such a communication system. These alternate possibilities should be explored more fully before any final decision can be reached. Once the relay net is constructed, information other than mobile communication could be transmitted and the cost of the relay net could be spread over many more users.

RAILROAD COMMUNICATIONS SYSTEM

Another application where a mobile communications capability is required is for a high speed railway linking urban areas such as Boston and Washington. Since the broadcast frequencies must not interfere with existing channels and because of limited spectrum availability, the relatively unoccupied frequencies well above 10 GHz must be given primary consideration (as was discussed for the urban communication system.) The relay net for the railway communications system is somewhat simpler than for the urban case since the topology of the relay net now is primarily one dimensional (along the tracks) instead of two-dimensional. Line-of-sight communication, at frequencies above 10 GHz, must be maintained by the broadcast link coupling information between the relay net and the train. One possible approach is to place a transmission network along the railway route with transmitter-receiver units mounted on poles or other supporting structures with pole spacing and antenna patterns adjusted so that the tracks would

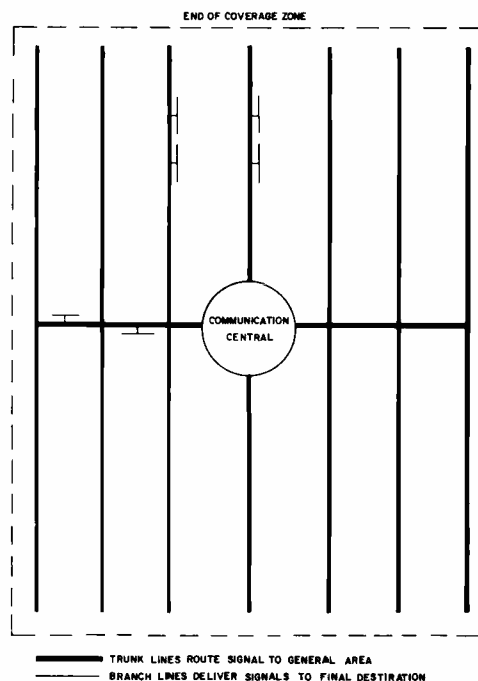

Fig. 2—Topology of relay net.

be completely illuminated by the array of transmitters (see Fig. 3). The antenna for the train could be mounted on the roof or one side. The fixed antennas along the train bed are necessarily broad-beam and therefore of relatively low gain although the train's antenna can have substantial gain.

With the above system, the signals could, for example, be relayed along a cable at baseband frequency. Other relaying techniques such as a low loss waveguide or transmission line as well as a millimeter or optical wave relay may turn out to be more appropriate. The suggestion of using cable is for descriptive purposes only. Furthermore, the cable may be in the form of either one wideband cable or several narrower-band cables.

As mentioned earlier, the link for coupling information between the (cable) relay net and the train is at a frequency well above 10 GHz. An estimate of the transmitted power required may be derived from the well known equation

$$P_r = P_t G_t G_r (\lambda/4\pi R)^2 e^{-\alpha R} \quad (1)$$

where P_r is the power received by a matched receiver; P_t is the power transmitted; G_t is the transmitting antenna

Fig. 3—Tracks are illuminated with RF energy.

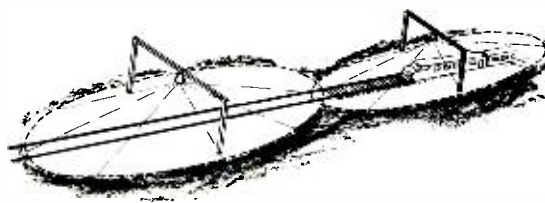



GERALD S. KAPLAN received the bachelors degree (cum laude) in electrical engineering from City College of New York in June 1962. He received the masters degree from Princeton University in 1964. Currently, he is attending the Polytechnic Institute of Brooklyn. He joined the staff of RCA Laboratories in 1962, and while on the research training program, participated in studies concerning evaporated thin-film diodes and cryogenic devices. Since becoming a member of the Communications Research Laboratory in 1963, Mr. Kaplan has performed basic studies such as an analysis of the effects of high altitude nuclear explosions on communication systems and research into the ultimate limitations on underwater reception of electromagnetic signals. More recently, he has been concerned with mobile communication systems. Mr. Kaplan is a member of Tau Beta Pi, Eta Kappa Nu, and the IEEE.

gain; G_r is the receiving antenna gain; λ is the wavelength; R is the propagation distance; and α is the attenuation coefficient (atmospheric absorption due to rain, water vapor, etc.).

The fixed antennas along the train bed would probably have gains of approximately 6 dB while the train's antenna could have a much higher gain—perhaps 40 dB. If λ is 2.5 cm (12 GHz) and R is

300 meters, the free space loss $\left(\frac{4\pi R}{\lambda}\right)^2$ is

103.6 dB. At 12 GHz, atmospheric attenuation over a 300-meter path is negligible and the total loss becomes 103.6 - 40 - 6 = 57.6 dB. Therefore

$$P_r = P_t - 57.6 \text{ dB.} \quad (2)$$

The power required at the receiver depends on the modulation method, the receiver noise figure, information bandwidth, and the signal-to-noise ratio required. To give feel for the power involved, the following calculation is presented.

An information bandwidth of 50 MHz to the trains was assumed together with an initial "guestimate" of a receiver noise figure of 13 dB and FM modulation with a peak deviation of 150 MHz. Most of the bandwidth is used for passenger service such as telephone or phonovision channels with a small fraction used for com-

mand and control information. If CCIR standard preemphasis signal-shaping characteristics are used, the FM processing gain becomes 20 dB for the above parameters. The noise power in the resulting 400 MHz IF bandwidth for a 13 dB receiver noise figure is -150 dBW. To provide a channel s/n of 40 dB, the carrier-to-noise ratio should be 20 dB; thus, the power required at the receiver is -150 + 20 = -85 dBW. From Eq. 2, the transmitter power required is -27.4 dBW or approximately 2 milliwatts. Therefore a power source having 10 to 100 mW capabilities should be adequate for wide-band communication at a 300-meter distance. The 300-meter range indicated in the above calculation suggests that the radio coupling links along the relay net should have a spacing of approximately 600 meters. Higher frequencies could also be considered for use in the radio link. At approximately 40 GHz, the effect of atmospheric attenuation due to rain is less than a few dB on a 300-meter path length. However, the free-space spreading loss $(4\pi R/\lambda)^2$ is about 11 dB higher at 40 GHz than at 12 GHz. This additional attenuation may partly be compensated for by the higher antenna gains which are more readily achievable at the higher frequency.

The above factors indicate that the power required at 40 GHz should be under 100 mW and possibly less than 10 mW. Inexpensive solid state power sources at the above mentioned frequencies and having the adequate power are expected to be available in the next several years.

The above factors indicate that the above system would operate as follows. Information from a communication center would be sent to the relay via appropriate connecting links. The net relays the message down the line, and at each of the fixed pole mounted units, the baseband information is modulated and broadcast to the train. While speeding along, the train receives the RF signal, demodulates it and recovers the baseband information. Return signals from the train, at a frequency different from that received, are received by the pole-mounted units and then relayed back to the communications center.

There are some potentially serious problems that can arise from this implementation. Perhaps the most crucial may be termed the "hand over" problem, which has two major aspects:

- 1) Multipath fading which can arise when two signals, out of phase, but of comparable strength are received by the same antenna.
- 2) Time delay which is a result of the two transmitters being separated, in time, by the time delay involved in traversing the 600-meter interval between transmitters.

Multipath fading may cause a reduction of the wanted signal below threshold, leading to errors and loss of information. For the railway communication system, this situation may arise when the train's antenna is located approximately midway between two of the fixed transmitters (Fig. 4). In this situation, interference can occur when transmitter A "hands over" to transmitter B the function of transmitting information to the train.

This potential problem can be overcome by using a novel angular diversity technique. Assume that the train has a fairly high gain antenna pattern (in the 40 dB range) whose axis of symmetry and maximum gain is along the horizontal. Assume further that the antenna gain is constant from the axis to an angle θ_0 from the axis (where θ_0 is of the order of a few degrees) and then falls off as $\csc^2\theta$ from $\theta = \theta_0$ to $\theta = \pi/2$. Beyond $\pi/2$ the gain should be as low as can be achieved. Such a pattern is indicated by the solid curve in Fig. 5. There is also a second antenna whose pattern is the mirror image of the first as indicated by the dotted curve in the same figure.

Operation would proceed as follows (Fig. 5). While the train is within 300 meters of transmitter B, the dominant signals come from this transmitter. Reception on the forward-looking antenna occurs when the train is moving towards transmitter B while reception on the backward-looking antenna occurs when the train is moving away from transmitter B. As the train approaches transmitter B, the received signal strength will remain constant since the $\csc^2\theta$ pattern compensates for the changing propagation distance. However, as the train passes transmitter B (θ becomes greater than $\pi/2$) the received signal starts to decrease (due to low gain for $\theta > \pi/2$) and increasing separation between transmitter B and the antenna on the train) and an automatic switch to the backward-looking mode of reception occurs. When the train has passed transmitter B and is approximately midway between transmitters B and C, the received signal from B begins to decrease and a switch (hand over) is made to the forward-looking antenna now views transmitter C only and the cycle begins again. Note that signals from B and C do not interfere with each other due to the discrimination

Fig. 4—Signals from transmitters A and B are comparable, leading to a potential fading problem.

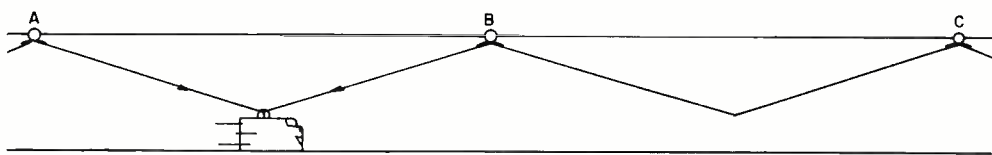

possible with the chosen antenna pattern. The antenna could be a single array capable of having its pattern electronically switched or actually two separate antennas which could alternately be switched into the receiver.

The time-delay part of the hand-over problem arises because the signals from the fixed transmitters are separated, in time, by the time delay involved in traversing the (600 meter) interval between the transmitters. This time delay may be of the order of 3 microseconds. The angular diversity technique described above eliminates the fading or mutual interference problem but does not obviate the problem of a sudden change in phase of the received signal. The seriousness of this problem is dependent on the type of information being sent. For instance, voice telephone channels are almost certainly unaffected since the information rate is quite low and the natural redundancy in normal speech serves as a built-in error corrector. Command and control channels can be safeguarded against this possible information loss by providing error-correction coding into the message structure. There is a potential problem, however, with the reception of television signals which may necessitate the use of a driven sync receiver so only a single line at most might be lost. An alternative is to confine the switching to the vertical sync interval. This would insure that picture "tearing" would be restricted to the top of the picture and would be concealed. Electronic circuits on board for such individual switching would process the received signals to insure the proper switching procedure.

As with the urban communication system, adequate consideration must be given to the topology of the relay net (i.e. trunking and branching networks) to insure that the signal passes through the minimum number of repeaters. The use of redundancy in equipments to prevent "blackout" of the communication system due to catastrophic failure of one major element in the relay net (such as a repeater) should also be employed.

As indicated above, there are many factors to be considered in determining the configuration for a future railway communication system. The above discussion just touched on some of the highlights. There are some situations which require only one way communication. An attempt to communicate by man on the move, which has a more immediate application than some of the other systems mentioned earlier, is considered next.

AID FOR MOTORIST

The Vehicular Traffic Systems Division

of RCA is presently marketing a system whereby a stranded motorist walks to a highway call box and, by selecting the proper button, can send one of four radio messages to summon different types of aid such as Police, Service, Fire, or Ambulance. The call boxes are placed approximately one mile apart (1/2 mile on some installations) necessitating a walk of possibly 1/2 mile by the motorist. This service, which allows man on the move to communicate his (one of four) woes to the proper authorities, is very much needed on many roads and highways. However, it is not always desirable to leave the car, especially late at night, in unfavorable weather, or in case of a serious accident. Therefore, some consideration was given to the possibility of implementing an "extension" from the motorist's car to the nearest call box. It was felt that the very low data rate required (only one button need be "pushed") as well as the low utilization rate of the channel by a given user (once every few months or possibly much longer) would allow existing mobile radio channels to be used without interference taking place. The two most important technical problems facing the motorist extension system are:

- 1) The receiver to be placed in the present highway call box must consume a minimal amount of power since the power for the call box is supplied by a battery which is recharged by solar cells.
- 2) Provision must be made to insure that the motorist does not activate too many of the highway call boxes since a) this hampers location of the motorist and b) the radio signals from the various call boxes can interfere with each other at the receiving station and the message may be lost.

The first problem is essentially one of proper circuit design and is not discussed here. The problem of turning on too many call boxes arises because of uncertainties in received field strength at the call box as well as uncertainties in the required field strength to trigger the call box. These uncertainties arise from a multitude of causes: the transmitter power may have varied from its nominal value; the terrain of each highway or even sections of the same highway may vary greatly; the distance from the car to the nearest call box is not fixed since the automobile may be anywhere between two call boxes; or the call box receiver,

being outdoors and subject to various weather conditions, may have its characteristics altered resulting in a changed threshold input signal. Therefore it is very difficult to transmit just the proper amount of power to trigger the nearest call box only and not any others. A possible solution to this problem could be to use a technique which is termed "power stepping." This involves sending the message to the call box at a low power level at first and then at increased power levels until a call box is triggered. The triggering of the call box sends a message to the base station at Police Headquarters, and this same signal may be used to stop the power stepping process at the automobile. At the same time that power stepping is stopped, an indication could be given to the motorist that his message was transmitted to the authorities and he can relax and stop pressing the "help" button.

CONCLUSIONS

The demand for communications with man on the move is ever increasing because more people are on the move than ever before, coupled with a need and desire for communications capability. Limited-spectrum availability precludes the use of presently utilized mobile frequencies to satisfy this growing demand and dictates the consideration of the higher and relatively uncongested frequencies. Many advances in the ability to generate, modulate, transmit, and receive electromagnetic signals at centimeter, millimeter, and optical wavelengths have occurred in the past and, no doubt, will continue to occur in the future. Low power devices operating at the above frequencies and utilized in conjunction with a relay network will be able to provide the capabilities necessary for future communication with man on the move.

ACKNOWLEDGEMENTS

The author thanks Dr. Harold Staras for his encouragement and extremely valuable advice during the preparation of this paper. Discussions with Dr. Gordon Fredendall concerning the possible deleterious effects on television signals due to the "hand-over" problem were very helpful. Many interesting discussions were also held with Irving Kalet, now at Columbia University.

Fig. 5—Angular diversity technique for improved signal reception.

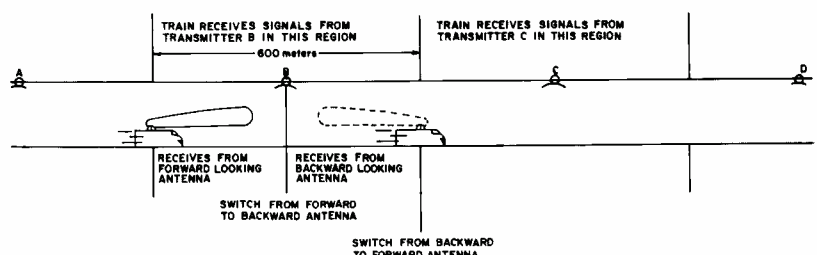

THE WORLD'S MOST POWERFUL TELEVISION TRANSMITTER

RCA's TTU-110A television transmitter, the world's most powerful TV transmitter, uses two broadbanded 55-kW klystrons to provide 110 kW of output power. This unit is the premiere model in RCA's "new look" line of UHF transmitters and is designed to provide its rated output on any TV channel in the 470- to 890-MHz frequency range. The five-cavity klystron designed especially for the TTU-110A and its vapor-phase cooling system are discussed, along with the exciter-modulator and the transmitter power supply.

D. R. MUSSON, Mgr.

*UHF TV Transmitter and Auxiliary Equipment Engineering
Broadcast and Communication Products Division,
Meadow Lands, Pa.*

Fig. 1—View of the main RF and control cabinets for the TTU-110A transmitter.



THE world's most powerful television transmitter, shown in Fig. 1, is part of RCA's growing family of UHF television transmitter products. This article describes the development of the RCA TTU-110A television transmitter, the culmination of the design effort required to produce a complete line of high-powered television transmitters.

The RCA "new look" line of UHF transmitters was introduced nearly four years ago. The first three transmitter types were introduced simultaneously. The first, the TTU-2A, is a 2-kW, air-cooled transmitter using high-power (RCA 8501) UHF tetrodes as the final

Final manuscript received November 1, 1967.

amplifiers and traveling-wave tubes as driving amplifiers. The second, the TTU-10A transmitter, employs a 10-kW amplifier consisting of two RCA 8501 UHF tetrodes in parallel, driven by the TTU-2A. The third transmitter, the 30-kW TTU-30A, was the first to employ a vapor-cooled, integral, four-cavity klystron amplifier designed solely for television service.

The first group of these television units was installed and placed into service in the United States in 1964. In 1965, 55-kW, TTU-50B, transmitters, employing single 55-kW visual klystrons, were placed into service. The following year these units were converted

to parallel 30-kW amplifiers, and the resulting equipment was denoted the TTU-50C. A variant, the TTU-50C1, was added to the line to provide custom installation flexibility and the optimum reliability of redundant systems. More than 50 RCA "new look" UHF-TV transmitters are now in use; the majority of these are high-power units based on the TTU-30A.

Early in 1968, the first TTU-110A, 110-kW transmitter, will be placed into service on Channel 17, WPHL-TV, Philadelphia. This transmitter uses Varian VA953, 5-cavity, 55-kW television klystrons. It is vapor cooled, and designed for remote control and one-man operation. This article describes the design philosophy employed in this "top-of-the-line" unit.

EXCITER-MODULATOR

Fig. 2 is a view of the exciter-modulator used with the TTU-110A transmitter. The unit delivers a visual-modulated signal of 1 to 2 watts on any 6- to 8-MHz channel between 470 MHz and 890 MHz. The aural output delivered by the unit is a high-quality frequency modulated signal on a frequency 4.5, 5.5 or 6 MHz above the visual carrier frequency, depending upon which television system is being employed. (There are twelve recognized systems throughout the world, the U.S. system¹ is designated CCIR system *M*.² The UHF exciter-modulator will also operate on CCIR systems *G*, *H*, & *I*, and can, with some modification, be employed on other systems.)

A signal flow diagram for the exciter-modulator is shown in Fig. 3. RF energy with a frequency between 8 and 12 MHz is generated in the master crystal oscillator. The output of this stage is multiplied (typically by a factor of 48) to a frequency approximately 40 MHz below the desired channel frequency. This signal is then heterodyned with the fourth harmonic of the oscillator output to obtain the desired carrier frequency. The plate cavity of the visual mixer-amplifier is tuned to the sum frequency of the mixed pair. In the case of visual service, the stage is grid modulated with the video information and the output cavity is broadbanded to accommodate the visual-sideband information.

The multiple use of this pencil-triode output stage, as mixer and modulated amplifier, is accomplished as follows: the video (dc to 6 MHz) and the 40-MHz fourth harmonic of the crystal frequency are impressed upon the grid, and the UHF-drive frequency (40 MHz below the final carrier frequency) is impressed on the cathode. The grid bypass capacitor causes the stage to operate grounded

grid at the UHF-drive frequency. Because each frequency is separated from the others by a decade, there is a minimum of interaction among the input circuits supplying the different inputs.

Several advantages are gained by using the single-frequency (master-oscillator) generation and mixing approach to achieve final carrier frequencies. First, a "new look" FM exciter is used to generate the aural-modulated carrier that is heterodyned with the UHF-drive frequency in the aural mixer to produce the final aural-output frequency. This assures optimum FM quality and standardization with the FM transmitter line. Second, the aural-to-visual frequency separation is governed, for all practical purposes, by the frequency stability of the FM exciter. Thus, the requirement of $F_{V-A} = 4500 \pm 0.5$ kHz is met with equal ease on all channels. Furthermore, any incidental frequency modulation induced mechanically in the UHF-multiplier chain appears equally in aural and visual carriers. Since inter-carrier sound demodulation is employed in the receivers, even substantial modulation of this type which might be present goes undetected.

The video-amplifier section is similar to that employed in earlier VHF and UHF television modulators. In addition to amplifying the video information to the level necessary for modulating the visual mixer, this section provides pre-emphasis of amplitude and phase linearity to offset the inherent phase and gain nonlinearities experienced in the modulated stage and final amplifier. The phase and gain characteristics of the klystron amplifier will be analyzed later.

The power source for the UHF exciter-modulator is a completely solid-state power supply with precise regulation on the B+ outputs. The DC level of the RF visual-modulated carrier is maintained by a clamp-pulse-type DC-restoration circuit. DC references in the linearity correctors are also derived from the clamp-pulse stages. The clamp pulses are formed from synchronization pulses stripped from the input video. It is possible to disable the restoration circuits for AC-sweep testing of the transmitter.

The exciter-modulator is employed in similar manner in the TTU-30A, TTU-50C and TTU-110A transmitters. The description of the general use in the system applies to all three transmitters.

INTERMEDIATE POWER AMPLIFIERS

The outputs of the exciter-modulator, both aural and visual, are amplified in a similar manner. The modulated RF signals feed through variable UHF attenuators which are drive controls for

the final amplifiers. The outputs of the variable attenuators are fed through diode detectors that drive DC meters used to indicate the relative drive levels to the intermediate power amplifiers. The IPA's in both the aural and visual transmitters are grounded-grid triodes. The tube employed is a 7289-A planar triode, with a plate dissipation of 100 watts. The input line to the cathode circuit is a quarter-wave coaxial network on the lower channels, below 650 MHz, and a three-quarter-wave network on all other channels. The plate cavity is a quarter-wave cavity on all channels and has an adjustable output coupling capacitor feeding the 50-ohm output line. In the visual side, the amplifier is coupled into a ferrite isolator to provide an optimum load and to isolate the amplifier from the highly mismatched load presented by the first klystron cavity. A similar circuit is in the aural side of the transmitter. The TTU-110A requires 2.5 watts of drive to produce more than 110 kW of peak visual power; the driver complex easily meets this requirement.

In the parallel amplifier transmitters, the RF drive from the visual driver feeds through a 3-dB directional coupler that is broadbanded for the entire UHF-TV frequency range. The output of the coupler is split to provide two signals at approximately equal power levels. One of these signals is fed to each of the two individual amplifiers through the ferrite isolators. The isolators provide an optimum load to the directional coupler and to the driver amplifier on the visual side. An RF coaxial patch panel, located in the second visual amplifier cabinet, allows patching of the input signals to the various klystrons or to test loads for setup as required. The RF line from one output of the 3-dB coupler feeds through a constant impedance line-stretcher which

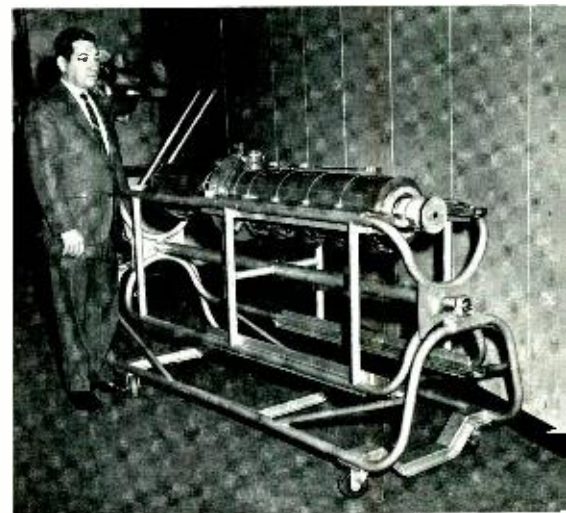

Fig. 4—55-kW klystron in carriage.

allows the selection of the electrical length of the cabling to the visual No. 2 klystron. By selecting the appropriate cable length, two klystron outputs are fed to the input of a bridged diplexer in phase quadrature. The line-stretcher length is adjusted to minimize the diplexer reject power when the two klystrons are set for equal outputs.

KLYSTRON AMPLIFIERS

The use of klystrons in television transmitters was started in 1952, when a 3-cavity tube was tested and placed into service. A more modern tube was made available in 1961. This device, an external cavity design, was employed in a modern klystron transmitter in 1963. A new family of klystrons, conceived solely for television service, was introduced in 1963, and first placed into service in 1965 in the RCA TTU-30A. The latter two tubes were evaluated in an extensive study of modern klystrons which culminated in the choice of the integral cavity tube for use in this family of transmitters. From the onset,

Fig. 2—UHF-TV Exciter-Modulator MI-560382A/B. Fig. 3—Block diagram of the exciter-modulator.

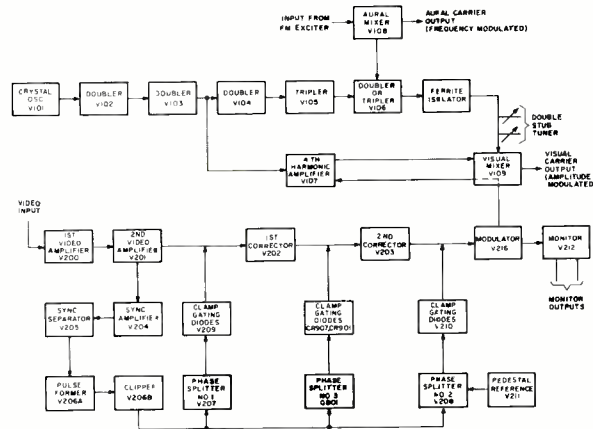
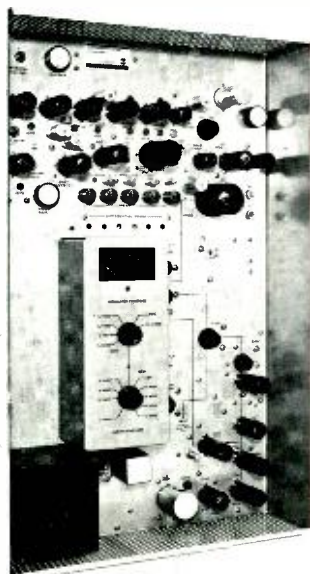



D. R. MUSSON received the BSEE from Michigan State University in 1956. Upon graduation, he joined AT&T Long Lines Division. Following completion of two years active duty with the US Army Ordnance Corps, as engineer in charge of the OTAC Lighting Laboratory, he assumed the position of director of technical operations for Gross Telecasting, Inc. (WJIM-TV) Lansing, Michigan. In December, 1958, he joined RCA in the Broadcast Transmitter Engineering Section in Camden. He served as project engineer on various transmitters, including the BTA-50H Ampliphase AM Broadcast Transmitter, the BTA-10J AM Transmitter, the new look TTU-30A, TTU-50B and TTU-50C high power UHF Television Transmitters. He was appointed Leader of the UHF Television Transmitter group in 1965. In 1966, he was appointed Manager of the UHF Television Transmitter and Auxiliary Equipment Engineering group. In this capacity, he directs the engineering effort of the RCA UHF Transmitter and TV Transmitter test, monitoring and video equalization equipment. Mr. Musson is a Member of Tau Beta Pi, Eta Kappa Nu, Phi Kappa Phi, IEEE and AFCEA.

the concept was to have a tube body that would be capable of either 30- or 55-kW operation, with only a change of the collector dissipation capability, and incidental changes in output circuit geometry required to reach the higher power level.

This scheme was carried out in 1965 with a four cavity 55-kW tube, but due to certain instabilities, the design plan was not carried to completion until 1967. At that time, the search for a better gain-bandwidth product, in addition to more uniform phase linearity and sideband characteristics gave impetus to the design of a 5-cavity 55-kW tube. This tube (Fig. 4) was first employed in the TTU-110A. It has, however, created much interest in several

foreign manufacturing companies engaged in production of broadcast equipment. The high gain and optimum phase linearity and frequency response, coupled with advantageous mechanical and electrical features, make it an ideal klystron for television amplifiers.

The klystron as a television amplifier is comparable to a stagger-tuned cascaded amplifier. The general characteristics for an essentially flat response in staggered quadruples or staggered quintuples are also pertinent to the design of a klystron amplifier. In the four cavity tube, two circuit poles are broadband (cavities 1 and 4), and two are high Q (cavities 2 and 3). The addition of a fifth cavity (low Q) significantly improves the operation as an essentially flat broadband amplifier.

Fig. 5 depicts the cavity tuning for the 4-cavity television klystron and indicates how the broadband response is obtained. The characteristics of the 4-cavity tube are such that the output cavity is one of the broadband poles because that cavity is loaded by the output transmission line. It is purposely tuned to the visual-carrier frequency in order to achieve the highest operating efficiency. Cavity No. 1, loaded by the input transmission line, is the second broadband cavity and is staggered to the high frequency side of the characteristic. Cavities 2 and 3 are the outside high- Q pair. Typical gain at mid-characteristic (approximately 50% voltage level) is 42 dB, while the saturated gain is 38 dB. Adding the fifth cavity results in a saturated gain of 46 dB, and a mid-characteristic gain of 50 dB.

The use of the klystron as a television amplifier is most impressive from the standpoint of its gain-bandwidth product. Not so desirable are several other characteristics such as the sensitivity of RF phase to beam-supply variations, and the less-than-linear transfer characteristic. Fig. 6 shows the typical transfer characteristics of the tube. As the

bunching increases in the beam, greater repulsion of the electrons in the bunch provides a nonlinear characteristic. At maximum bunching (highest power) the linearity is the worst. The characteristic can best be described as that of a Bessel function of the first kind and order one, i.e., $y = J_1(x)$. The fundamental energy is amplified according to the transfer curve described by the equation. The incremental linearity can be obtained by using the recurrence formulas to take the first derivative

$$dJ_1(x)/dx = [J_0(x) - J_2(x)]/2.$$

The incremental linearity of the klystron amplifier is tabulated in Table I over the standard staircase increment of the video signal in which there are ten steps from black to reference white. The compression of the amplifier relative to the mid-characteristic level (step five) is also shown in Table I. Linearity in the black region is of particular concern in that the maximum amount of pre-emphasis of the drive signal is required at this point. Since relatively high pre-emphasis components exist in the black region, particular care in the transmission system is taken to assure their faithful reproduction at the input of the klystron, so that the maximum system linearity can be realized at its output. Synchronization pulses must be expanded by at least 6 dB to achieve a reasonable efficiency at the output of the tube. The fact that the klystron has a constant DC input, irrespective of its RF output level, is a considerable price to pay in using it as an amplifier. Trying to reduce the dynamic range to provide maximum signal linearity and thus reducing pre-emphasis requirements, makes the efficiency even more unreasonable. During the development of the TTU-30A, a study was made to determine the pre-distortion of the video signal that could be tolerated on the overall system while achieving adequate linearity and best efficiency. The result is the system de-

Fig. 5—Pictorial representation of cavity tuning.

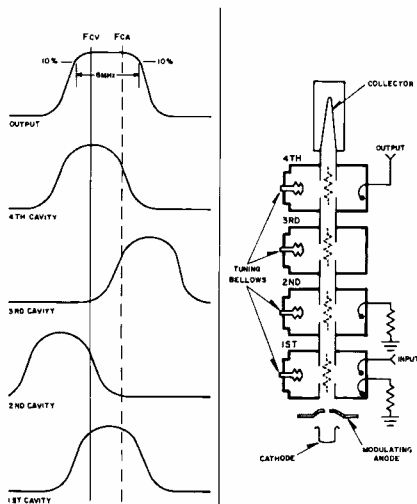
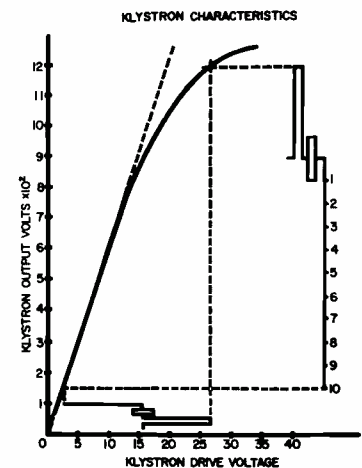

Fig. 6—Klystron transfer characteristic (amplitude).

TABLE I—Bessel Solution of Klystron Characteristics

Video Level (envelope)	Argument (x)	$dy/dx (J_0 J_1)/2$	Compression y_1/y_5	(dBs)
0	0.971	0.337	0.75	2.5
1	0.861	0.367	0.81	1.8
2	0.767	0.394	0.87	1.2
3	0.684	0.415	0.92	0.7
4	0.596	0.435	0.96	0.3
5	0.515	0.451	1.00	0
6	0.439	0.464	1.03	-0.3
7	0.363	0.475	1.05	-0.5
8	0.288	0.485	1.07	-0.6
9	0.215	0.491	1.08	-0.7
10	0.142	0.497	1.09	-0.8
11	0.072	0.499	1.1	-0.9
12	0.000	0.500	1.1	-0.9
-1	1.074	0.300	0.67	3.6
-2	1.175	0.265	0.59	4.6
-3	1.360	0.196	0.43	7.2
-4	1.600	0.099	0.22	13.1



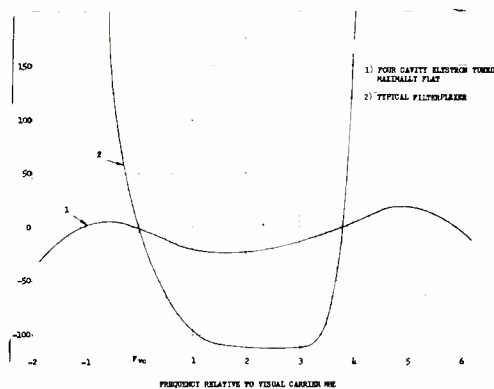

Fig. 7—Envelope delay before correction.

fined in the table and which uses the klystron to within 3 or 4 kilowatts of its absolute saturation power.

A second problem in this velocity-modulated amplifier tube, is that of beam retardation as the power is extracted at the output section of the tube. Slowing of the beam is caused by the extraction of kinetic energy from the electrons passing the output gap. Since the output energy at peak-power output is approximately one-third that of the dc energy in the beam, the average beam energy is reduced by one-third. At white level, or very low RF output, little beam retardation occurs, but at black level, the retardation is considerable. The change of RF phase between these two levels is approximately 15 to 20 degrees.

It is important in color transmission that the phase of the color subcarrier, located 3.58 MHz or 4.43 MHz above the visual carrier, be the same as that at the input, independent of the monochrome output level. Therefore, the envelope phase shift introduced by the slowing of the beam must be minimal or must be corrected by pre-emphasis in an earlier stage (exciter-modulator). It would appear, on the surface, that the slowing of the beam causes untenable phase distortions. However, since the carrier and the 3.58-MHz sideband energy are simultaneously retarded by

similar amounts, the *differential* phase shift between the carrier and the upper sideband (envelope phase shift) is approximately equal to the percentage bandwidth between the two energies.

Since all modern television receivers use intercarrier sound or the beat frequency between visual and aural carriers (4.5 MHz in U.S. standard) to generate the IF frequency, the beam slowing of the visual does impose FM sidebands on the aural IF carrier, but these are relatively low in magnitude and the frequencies generally high. Therefore, they do not interfere with the audio intelligence carried on the FM carrier.

To assure minimal FM generation due to beam-supply variation, the transmitter purposely receives its beam energy from a supply common to both the aural and visual tube. Any variation in dc level changes the phase of both the aural and visual carriers simultaneously, and by approximately the same number of degrees, differing only by the percentage frequency between aural and visual carriers. This avoids the necessity of having to phase, carefully, the ripple component of two independent beam supplies.

The only tuning element in each cavity of the klystron is a capacitor tuner, which comes in from the front side of the tube. It closes very near to the drift-tube gap when tuned to the low-frequency end. The geometry of the cavities, tuners, and coupling mechanisms was chosen to provide uniform operation from the low to the high-frequency end in each tube. The proof of the excellence of design in this area is represented by the minimal variation of efficiency with respect to output frequency. (The typical change of efficiency is about 2% from one end of the UHF-TV spectrum to the other.)

The phase linearity of the klystron amplifier is of primary importance because, in a television system, it is es-

sential that all the frequencies transmitted arrive at the received location in proper timing. If information on the sideband extremes is delayed unnecessarily due to phase nonlinearity in the amplifier, the relative timing of the detected signal in the home receiver is impaired and visible distortion results. The color subcarrier frequency, which generates the chrominance information in the receiver is particularly sensitive in this respect. Timing errors at the high-frequency end of the passband will result in misregistration of the color information over the monochrome, causing a condition similar to registration errors in multi-color newspaper printing.

To achieve optimum timing of the signal, the phase linearity of the amplifier must be maintained, or the resulting delays must be corrected. Fig. 7 represents the typical envelope delay ($d\phi/d\omega$) characteristics for a multiple-cavity, stagger-tuned klystron. The envelope delay of the klystron in the region of the visual carrier is particularly important if low-frequency smear and overshoot are to be avoided in the reproduced signal.

Other circuits in the transmitter also contribute to envelope delay. The most severe delay is introduced by the RF filter located at the output of the visual transmitter and used to limit the bandwidth of the signal to the confines of the channel. As shown in Fig. 7, this delay is considerably greater than that introduced by the klystron. In order to ensure a constant delay in the system, video equalizers are placed in the system ahead of the transmitter input. These equalizers pre-emphasize the signal timing in complementary form to the envelope delays introduced into the transmitter signal. Because it is not economical to manufacture a constant delay IF in a color television receiver, the resultant signal is purposely pre-emphasized on the high frequency side of the passband to counteract the delay inherent in home receivers.

Fig. 8—Unitized 250 kW beam rectifiers.

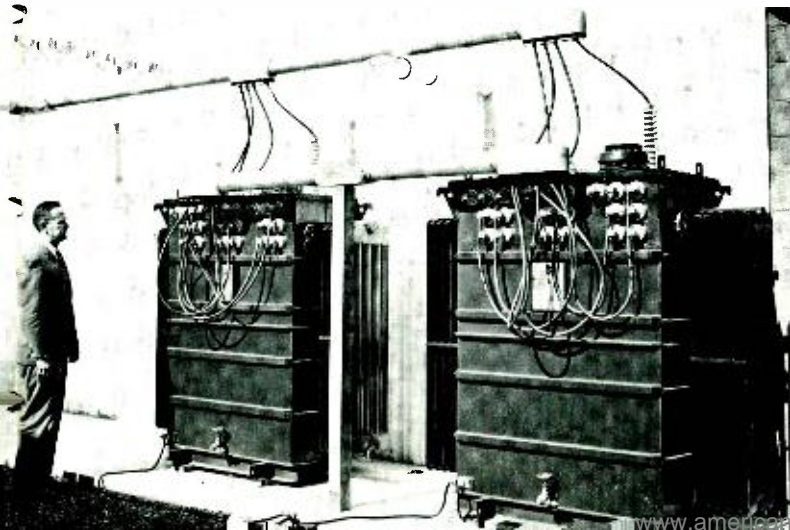
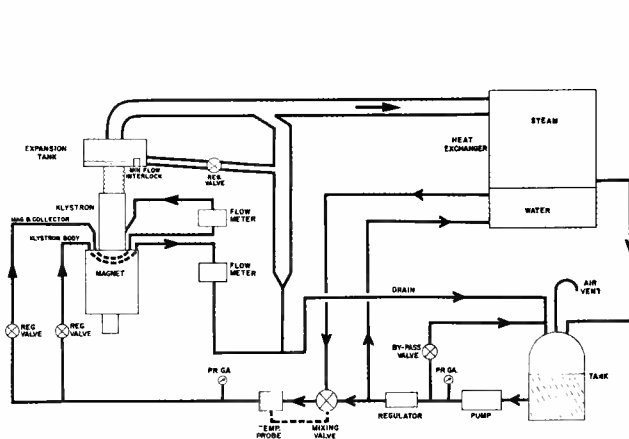

Fig. 9—Diagram of cooling system for TTU-110A transmitter.



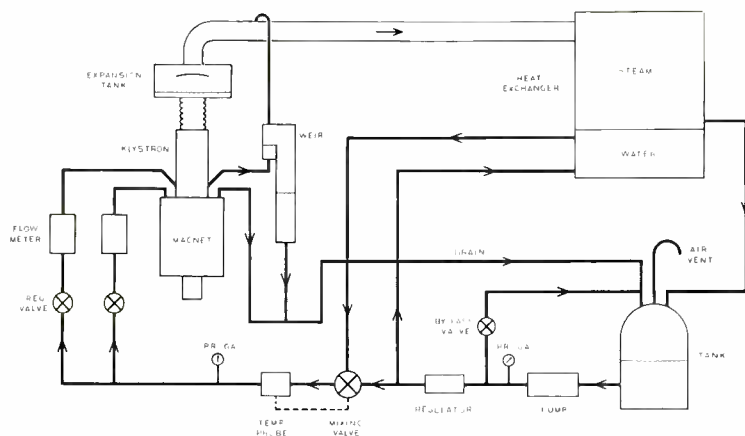

Fig. 10—Diagram of vapor cooling system for TTU-30A/50C transmitters.

Beam Supply

The dc beam supply in the TTU-110A comprises two all-solid-state, unitized-rectifier power supplies (Fig. 8). The transformer, rectifiers, rc snubbing networks, and reactors are all located within the oil tanks. One supply uses a wye connected secondary, the other, a delta secondary. The two supplies are paralleled to form a twelve-phase rectifier feeding a common filter capacitor. The primary ripple frequency is 720 Hz. Careful control of the transformer windings assures optimum phase-to-phase balance and minimizes the lower-frequency, 120-Hz, ripple. This configuration was chosen to minimize the size of the filter capacitor necessary to smooth the output ripple. The use of the smaller capacitor minimizes the stored energy available for catastrophic shorts internal to the tube, thereby minimizing any possibility of damage due to an arc. The design was chosen not only for its higher ripple frequency, but also for its capability for providing emergency operation. Should a fault occur in one of the unitized supplies, operation can be continued with the good unit, at 1/2 normal load, by disabling the AC input and DC output of the defective unit. The interphase reactor, normally required for balancing the output, is shorted in each supply to minimize the buildup of induced 360-Hz voltages.

Because the design of the electron optics in the klystron produces a nearly uniform beam, ripple on the output from

the dc supply has little effect on the video intelligence from the klystron. (With an imperfect beam that varied in diameter as a function of length, a variation in dc supply voltage could cause a variation of coupling at the output gap, and thus, an amplitude disturbance on the transmitted picture information.) Sync-tip ripple and carrier-phase modulation result from slight variations in saturation level and changes in the electrical length (due to changes in beam velocity) of the tube. However, as pointed out previously, relatively high values of phase modulation can be tolerated as long as both the aural and visual tubes are affected similarly.

Vapor Cooling System

The unused energy from the klystron is dissipated in a copper mass at the upper end of the tube. This collector is grooved to increase the surface area in contact with water. The water is turned into steam and carries away its heat of vaporization through the steam system to the steam condenser (refer to Fig. 9). The system is very efficient. The required 180-kW dissipation capability can be realized with a 1.25 gallon-per-minute flow of water into the klystron. In the TTU-110A, the cooling input water is controlled in temperature and flows through the magnet into the collector. In cooling the magnet, the temperature of the water is elevated to ahead of the tube, a temperature probe approximately 80°C, the temperature

at which it enters the klystron boiler. The water continues to rise in temperature and changes into steam at the rate of 0.7 gallon-per-minute for every 100 kW of power being dissipated. Additional temperature-controlled water enters the cavity cooling circuit to hold the body of the tube to a uniform temperature. The upper tuners are cooled to maintain their mechanical stability. The overall result yields a high degree of gain and phase stability throughout the tube. In practice, two tubes in parallel yield no more than 100 watts variation of diplexer (combiner) reject power from the cold to the warm condition over the various power levels encountered in the television signal.

The cooling system of the TTU-30A and TTU-50C employ an external weir to establish the water level in the klystron boiler. The differences between this system, and that used in the 110-kW transmitter can be determined by comparison of the flow diagrams (Figs. 9 and 10). The higher power tube, the 55-kW VA-953 employed in the TTU-110A, uses a controlled-overflow system in which a small amount of 100°C water flows along the base of the steam line into a reservoir, where it is collected and returned to the tank. This assures a positive height of boiling medium above the collector.

A unique water-level indicator in the steam separator, located at the top of the klystron cabinet, senses the presence of the boiling medium. If the medium is absent for a period of 15 to 20 seconds, the float within the indicator will drop, shutting off the dc beam supply. In addition, the flow into the magnet and collector is metered and interlocked for a specified minimum rate. The body cooling water is also interlocked in a flow-meter system. To maintain uniform input temperature of the water to the klystron cavity, a certain amount of water is pumped out from the reservoir and routed either directly to the tube or through the heat exchanger. The water is then recombined and sent to the tube. In the piping senses the water temperature and, in

Fig. 11—Removal and installation of klystron using handling fixture.



conjunction with a motorized valve, regulates the distribution of the water. This maintains the water temperature to within 2°C of a predetermined value.

The vapor cooling scheme allows the efficient transfer of large amounts of heat while requiring only a minimum of ac power for driving the heat exchanger system and pump. A major advantage of the system lies in the inherent efficiency of the steam condenser.

Mechanical Characteristics

The mechanical design of the transmitter facilitates installation and removal of klystrons, and a unique tube-handling scheme has been developed that is essentially the same for all of the "new look" transmitters. Fig. 11 depicts the scheme for the four-cavity tube. The tube body contains stainless-steel rollers which engage tracks inside the electromagnet. The tube and magnet are tilted to the horizontal position allowing the tube to be pulled out on its rollers to a waiting handling carriage. This carriage is on wheels and has positions for two klystrons. The spare tube is housed in the bottom position, and the tube being extracted from the transmitter is inserted into the top position. When the two tubes are in position, the carriage is indexed about its horizontal axis, lowering the used tube to the bottom of the cradle and raising the spare tube to the top-loading position. When the spare tube is locked in the upper position, it can be loaded into the electromagnet. The lower pole piece of the klystron mates with the lower pole piece and the lower surface of the magnet. When vertical, the tube actually rests on the lower pole piece, providing optimum field geometry in the gun region where it is most critical.

In addition to the RF connections to the tube, two other connections are required: the inlet-water and the steamboot connection, which is a flexible fitting for vibration isolation, and the slight electrical insulation for the collector. The klystron dc-connection plug contains a set of thermocouple wires which lead to a thermocouple imbedded in the collector. If the various water interlocks fail, the thermocouple provides a final level of protection for the tube. The thermocouple detects the rise of collector temperature and, by means of a meter-relay, turns off the dc supply, generally before the tube has a chance to outgas sufficiently to cause an internal arc. The meter-relay is red-lined at a temperature slightly above that of boiling water so that it will detect collector thermal-runaway before damage is done.

SUMMARY

The primary operating characteristics of the TTU-110A are listed in Table II. The levels of performance for the 30-kW and 55-kW transmitters are essentially better than those listed, as attested in the factory tuning facility before the transmitter leaves for the customer's

TABLE II—Specifications

Type of emission:	
Visual	A5
Aural	F3
Frequency range	470-804 MHz (Ch. 14-70)
Rated power output:	
Visual ¹	110 kW
Aural ²	12 to 24 kW
Carrier frequency stability:	
Visual ³	± 500 Hz
Aural ⁴	± 500 Hz
Audio frequency distortion	1% Max. 30 Hz to 15 kHz
Amplitude variation over one picture frame	Less than 3% of the peak of sync level
Regulation of output	3% max.
Subcarrier amplitude	± 10%
Linearity (differential gain) ⁵	1.5 dB max.
Subcarrier phase versus brightness ⁶	± 7° max.
Harmonic attenuation, ratio of any single harmonic to peak visual fundamental	-60 dB, minimum
AC line input:	440/460/480 V, 3-phase, 60 Hz
Slow line voltage variations ⁷	± 5% max.
Power consumption	Depends upon channel and aural ratio
Power factor (approx.)	90%

¹Measured at the output of the filterplexer.

²Measured at the input to the filterplexer.

³Maximum variation for a period of 10 days without circuit adjustment over an ambient temperature range of +10° C to +45° C. (Meets FCC specifications over an ambient range of +1° C to +45° C.)

⁴Maximum variation with respect to separation between aural and visual carriers.

⁵Maximum variation of amplitude of the sine-wave modulation frequency when superimposed on staircase or ramp modulation which is adjusted for brightness excursion stated. Modulation depth of the sine wave to be 20% peak to peak. CCR Linearity is 0.85 at 0.2 MHz, 1.5 MHz and 4.43 MHz with a Brightness excursion 65% to 17% at 0.2 and 1.5 MHz, and 75% to 17% at 4.43 MHz.

⁶Maximum phase difference with respect to burst, measured after sideband filter for any brightness level between 75% and 15% of the sync peak using 10% (peak-to-peak) modulation. This is equivalent to 5% (p-p) as indicated by a conventional diode demodulator. In addition, the total differential phase between any two levels shall not exceed 10 degrees.

⁷Each phase independently regulated (balanced). Regulator correction capability is ± 10%.

TABLE III—Remote Control Functions, TTU-110A

Function	Control	Metering
1	Spare	Calibrate
2	Transmitter ON/OFF	Fil. voltage
3	H.V. ON/OFF	Collector voltage
4	O.L. Reset	Collector current (vis.)
5	Spare	Collector current (aur.)
6	Vis. excitation RAISE/LOWER	Output (vis.)
7	Aur. excitation RAISE/LOWER	Output (aur.)
8	—	Spare
9	Blanking level RAISE/LOWER	Output (vis.)
10	Video gain RAISE/LOWER	Output (vis.)
11	—	Frequency dev. (vis.)
12	Spare	Frequency dev. (aur.)
13	Tower lights ON/OFF	Tower light current
14	Spare	Modulation (aur.)
15-19	Spares	Spares
20	Home	Spare

site. The overall stability of the system is very good. The precise control of dc levels in the exciter-modulator, and the overall line-voltage regulation aids in obtaining dc and RF stability.

Because a television station measures the off-air time in terms of hundreds of dollars, the overall reliability of the unit must be high. When a difficulty does arise, it must be circumvented quickly. For many serious problems, emergency modes of operation are provided in the TTU-110A. Spare exciters are offered as an optional feature. Reliability is enhanced by the use of redundancy in the dc-beam supply as well as in the magnet supplies. Each magnet supply in the TTU-110A transmitter is capable of driving two out of three tubes and there are two supplies provided. Thus, even if one supply is lost, the station can continue in operation with one visual tube and the aural tube in service.

If it is absolutely necessary, multiplex operation can be implemented where reduced aural drive is fed into the visual amplifier and the visual signal reduced to approximately 50% of normal power level. Under these circumstances, the station can remain in operation with a single klystron, while the output filter is bypassed and the FCC notified of the low-power emergency operation.

The TTU-110A is designed for complete, unattended remote-control operation. Several of the TTU-30A and TTU-50C transmitters are presently being successfully operated from remote distances with no personnel present at the transmitters. The information that is remoted is listed in Table III. The number of read-outs is kept at a minimum so that an accurate, simple log can be kept at the studio-control location.

In addition to the UHF transmitters described in this article, a complete line of UHF television transmitter test equipment is available from RCA. A UHF sideband response analyzer, BWU-5C, is offered which accurately determines the frequency response of the sidebands for set-up of the transmitters. For accurate detection of the transmitted signal by a vestigial sideband demodulator, the RCA BWU-4C is available as a "standard" receiver and monitor. In addition, linearity correction equipment, video delay equalizer equipment and measuring sets are available in the broadcast transmitter product line.

REFERENCES

1. FCC Rules and Regulations Part 73.
2. International Radio Consultation Committee, International Telecommunication Union.
3. L. S. Lappin, D. R. Musson, E. R. Hill, "Remote Operation of UHF Television Transmitters", *Broadcast News*, Vol. No. 131, pp. 40-45; December, 1966.

MOBILE COMMUNICATIONS BASE STATIONS

The demands of flexibility for low-, medium-, and high-power mobile communication equipments for indoor, outdoor, remote control, local control, and relay repeater installations resulted in the circuit designs described in this paper. Two basic designs—the super basefone and the super controlfone—satisfy these demands.

F. PAPOUSCHEK and A. N. MORTENSEN

*Mobile Communications Engineering Broadcast and
Communications Products Division
Meadow Lands, Pa.*

THE RAPID and continuous growth of mobile communications has created the need for effective, reliable, and versatile base stations capable of continuous operation. A high degree of frequency stability, particularly for the recently adopted UHF split-channel operation is required. Any practical design must be flexible enough to provide for the many possible system applications including repeaters, local and remote controls, mobile relays, and repeater-operated base stations, with a minimum of modifications.

TWO BASIC SYSTEM DESIGNS

With these requirements of application flexibility in mind, two basic base-station communication systems have been designed: the *super basefone* and the *super controlfone*.

These communication systems operate primarily on the 25 to 54 MHz, 148 to 174 MHz, and 450 to 470 MHz frequency bands with channel spacings of 20 kHz, 30 kHz, and 25 kHz, respectively. Phase modulation is used with the maximum frequency deviation limited to ± 5 kHz and the audio frequency range limited from 300 Hz to 3000 Hz. The RF output power of base stations ranges from 15 to 370 watts. The frequency, frequency stability, and power of base stations for mobile communications must comply with FCC regulations.

MODES OF OPERATION

A base-station system consists of a transmitter and a receiver, both working normally at the same frequency. This system contains an antenna relay to switch the antenna to the transmitter during the *transmit* period and switch to the receiver in the *receive* condition. The receiver is muted in the *on* condition. In the latest design, the transmitter is keyed by the push-to-talk switch which controls the drive by a solid-state switching device. In a repeater or mobile relay system, the transmitter and receiver operate on different fre-

quencies, but are operating simultaneously. The presence of a carrier (in the receiver) keys the transmitter by a carrier-operated relay or a tone-operated relay while the receiver audio output is used to modulate the transmitter.

Local Control

A standard base station can be controlled locally with a local control unit which is connected to the base station by a multiconductor cable. This control unit provides frequency selection, volume control, squelch control, and includes a standby light, a transmit light, a loudspeaker, and terminals for connecting a local microphone with its P-T-T switch.

Remote Control

The base station can also be remotely controlled from a remote control unit over a telephone line which terminates in the line-termination panel at the base station. This allows keying and modulation of the transmitter with optional frequency selection, quiet-channel disable, and remote squelch adjustment. Combinations such as repeaters with remote control and/or local-control override are possible.

SUPER BASEFONE TECHNICAL FEATURES

The basic design characteristics of the super basefone are:

- 1) Excellent frequency stability
- 2) Versatility of application
- 3) Wide range of available power output
- 4) Continuous duty rating

The frequency stability of ± 1 ppm, particularly important for the UHF split channels, is achieved by an oven-controlled crystal oscillator. The frequency remains well within ± 1 ppm over the temperature range of -30°C to $+60^{\circ}\text{C}$. Long-term stability is achieved by the use of pre-aged glass-enclosed crystals.

VERSATILITY

Since a base station may be used in any of the numerous system configurations, a high degree of versatility must be available. To provide this versatility, the

super basefone is built up of individual panels, each one designed to perform a specific function.

The panels are of standard size, 19 inches wide, accessible from the front and rear. Shield covers, hinged and equipped with captive screws, provide easy access for tuning and servicing. Each panel is equipped with 52 terminals on a rear terminal board, making all required connecting and servicing points accessible.

To save space, the terminal rear board is spaced several inches from the unit and hinged to provide ready access to the circuitry. It is not necessary to remove panels from the rack for tuning, servicing, or replacement of components. Slide-out modules are used for optimum accessibility. A basic cable is common for all systems, including local- and remote-control units, repeaters, and mobile relays. Many special systems can be obtained by reconnecting basic cable wires to appropriate terminals or by adding new wires to the system.

DESIGN DESCRIPTION OF THE SUPER BASEFONE SYSTEM

A typical base-station system (Fig. 1) has six main panels: transmitter, transmitter power supply, exciter, antenna panel, receiver, and power panel. Optional accessories such as quiet channel, or carrier-operated relay, are mounted in an accessory panel. For convenience of testing, an optional meter panel can be added.

100-watts Power Output

The transmitters (Figs. 2 and 3) deliver up to 100 watts of RF power continuously in the low (25 to 54 MHz) band and high (148 to 174 MHz) band, and up to 70 watts of continuous power in the UHF (450 to 470 MHz) band. The output from the exciter panel is fed to the first multiplier at the crystal frequency. Three stages of frequency multiplication are provided to raise the crystal frequency to the carrier frequency. The amount of multiplication depends on the band in which the transmitter is operating. In the low band from 25 to 36 MHz, the multiplication is 12; from 36 to 54 MHz, the multiplication is 18. The multiplier output is fed to the power amplifier.

A conduction-cooled long-life power tube, type 8072, is used in the power output stage. As required to comply with FCC limitations, lower power outputs may be obtained by using a lower plate voltage available at the transmitter terminal board. A small temperature controlled fan is used to cool the transmitter allowing continuous operation at $+60^{\circ}\text{C}$ ambient. The RF output of the transmitter panel is fed to the antenna relay panel which contains the coaxial

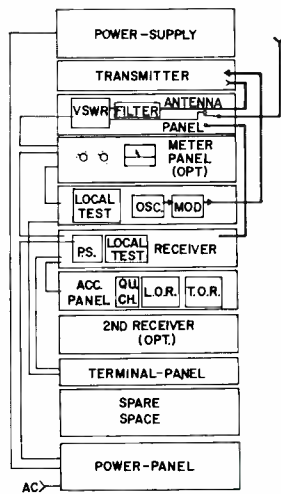

Fig. 1—A typical base-station communication system might consist of the units shown here.

antenna relay and, for some transmitter units, the low-pass filter which serves to attenuate the undesired harmonics.

Exciter Unit

The oscillator, modulator, and local test facilities are contained in the exciter panel (Fig. 4). The oscillators are contained in a thermostatically controlled oven maintained at a constant temperature of 65°C. Special cut crystals provide a frequency stability within ± 0.0001 percent. Multiple frequency operation up to four channels is available. Frequency selection can either be made locally at the exciter panel or at a remotely located control unit.

Exciter Modulator

Voice modulation is applied to the audio amplifier by a dynamic microphone, which contains a pre-amplifier. The audio amplifier in the exciter contains a limiter to prevent excess frequency deviation; maximum deviation is adjustable. An audio roll-off filter limits the upper audio frequency to 3000 Hz. The oscillator output and audio limiter output are fed to the phase modulator. The output of the modulator is applied to a buffer amplifier and then to the output amplifier. Mounting facilities for a three-minute, time-out timer used in repeater operations are also contained in this panel. The power is obtained from the transmitter power supply. A voltage regulator is incorporated in the exciter panel.

Transmitter Power Supply

The transmitter power supply provides all operating voltages both AC and DC for the system, except the receiver which contains its own power supply. The input to the power supply is 117-volts 50/60-Hz single-phase AC. Transformer taps are provided for 115-, 117-, and 125-volts inputs to compensate for variations in line voltages.

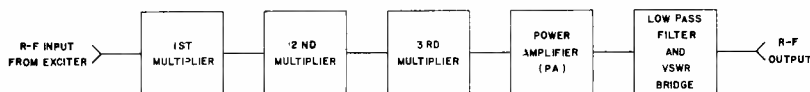

Fig. 2—Basic stages of the high-band transmitter.

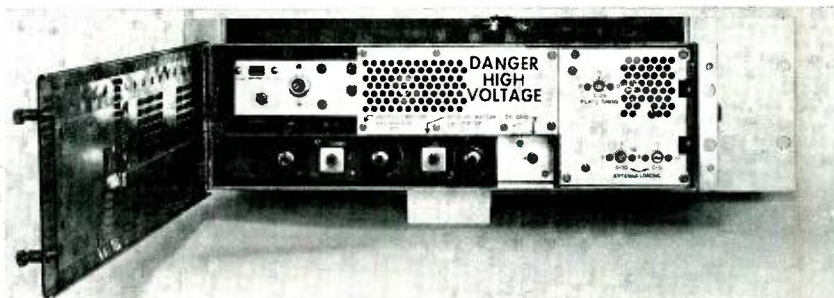

Fig. 3—Front view of a transmitter panel with covers swung open.

Receiver Unit

The receiver is a self-contained unit; it is provided with its own power supply and audio power amplifier. A mode-selector switch determines whether frequency selection, squelch adjustment, and audio monitoring are made locally at the receiver or at a remotely located control unit. A line amplifier (used to supply modulation to the transmitter in repeater applications) can also be mounted in the receiver.

The receiver (Fig. 5) employs dual conversion with crystal-controlled oscillators providing the first and second injection frequencies. The frequency of the first oscillator is 31.72 to 47.30 MHz

for the low-band and the high-band receivers, and 54.4 to 56.9 MHz for the UHF receiver; frequencies are multiplied four times to the first injection frequency. Four oscillators provide four-frequency operation. The high IF signal of 6.7-MHz is heterodyned with the second-injection frequency of 7.155 MHz to provide the low IF frequency of 455 kHz. A discriminator acts as the FM demodulator. The audio stages produce an output of 5 watts. A squelch circuit is provided which, in the absence of a carrier, allows the audio channel to be quieted. The squelch threshold or gating level is adjusted by the squelch control. Noise appearing at the output of the discrimi-

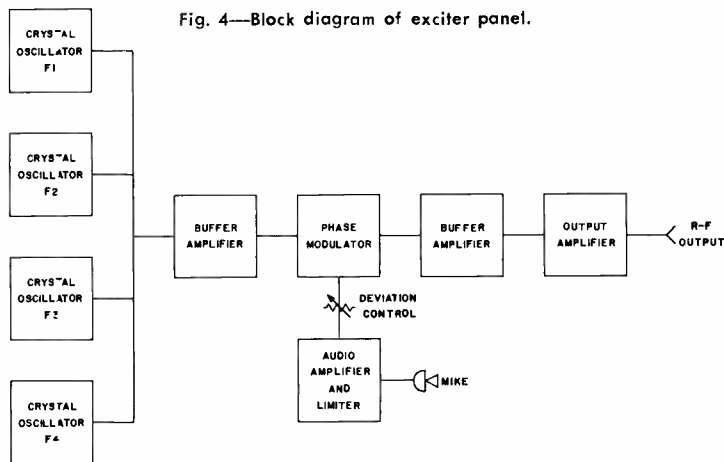

Fig. 4—Block diagram of exciter panel.

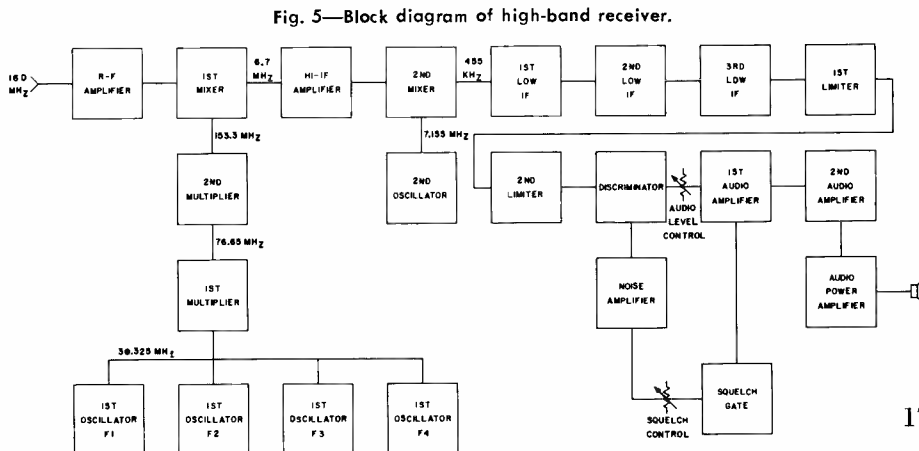

Fig. 5—Block diagram of high-band receiver.



FRANZ PAPOUSCHEK received his diploma for his Engineering Degree (MEE) at the Prague University, Czechoslovakia. He took post-graduate courses in Mathematics at the University of Berlin, and post-graduate courses in electronics at the McGill University in Montreal, Canada. He has been associated with the development of Communications and Broadcast Equipment since 1930. He joined RCA Victor Ltd., Montreal in 1951 as a project and development engineer in commercial and military communications projects, including communications receivers, VHF transmitters, SSB equipment, FM multiplexing receivers, airborne and marine equipment, and systems engineering. He was granted several patents in the field of frequency synthe-



sizers, communications circuitry, and mechanical devices. He is a member of the IEEE.

A. NORMAN MORTENSEN received his BSEE degree from the Kansas State University in 1962. He joined RCA in 1962, on a specialized training program. In July 1962, he was assigned to the Audio Communications Group, Surface Communications Division, Cambridge, Ohio, where he worked on test facilities for the AN/WIC communications equipment. He joined the Mobile Communications Group, Meadow Lands, Pa., in January 1964. Mr. Mortensen is concerned with the development of regulated power supplies, solid-state switching circuits; and communications circuitry for mobile base stations. He is a member of the IEEE.

nator is amplified and rectified; the rectified noise voltage is used to cut off the audio channel.

Fig. 6 shows the receiver with the hinged front cover opened, exposing the actual receiver module. At the left side is the audio amplifier panel with the test loudspeaker and local test and monitoring facilities. This panel can easily be removed for servicing. The power supply is mounted on the rear of the panel.

APPLICATION FLEXIBILITY

Accessory Panel

For example, an accessory panel contains facilities for mounting several valuable accessory circuits available with the super basefone; these include a continuous tone-controlled squelch system known as *quiet channel*, a carrier-operated relay, and a tone-operated relay.

The quiet-channel circuit is used in areas where more than one user may be assigned to the same carrier frequency; this unit provides tone-selective communication. A low-frequency tone is generated for modulating the transmitter. The audio amplifiers of the system receivers are normally gated off. Reception of the proper tone from a system transmitter at the tone decoder in a receiver allows a switching circuit to gate on the audio channel. Receivers in other systems on the same carrier frequency will not be affected by the tone if they are assigned different tone frequencies. A switch is provided to disable the quiet channel for monitoring the channel before transmitting.

A carrier-operated relay recognizes the presence of a carrier in the receiver and may be used to key on a transmitter. The tone-operated relay operates in the same manner as the quiet-channel unit except that a relay is substituted for the

audio-channel switching circuit. The relay may be used for various switching functions such as keying a transmitter. The accessory panel is so designed that other special function options may readily be adapted for use with the super basefone.

All these options are equipped with push-on connections and more than 260 connector pins are provided on the accessory panel to interconnect these units with the system. Several of these accessories can be powered from the receiver power supply. However, when more power is required, a receiver power supply module can be mounted directly on the accessory panel.

Terminal Panels

All connections for external control of the base station except for antenna and line-voltage connections are made to 52 terminals at the rear of the terminal panel. For base station systems designed to be operated from a remote point over a telephone line, a line-termination panel replaces the terminal panel. The internal cable connections to the line-termination panel are the same as for the terminal panel except that provision is made for connecting a telephone line to a 600-ohm line transformer. A handset is supplied which allows monitoring of the channel at the base station. The handset may also be used to transmit directly from the base station or for intercommunication between the base station and the remote-control point. A two-frequency kit and low-voltage relay kit for quiet-channel disable are also mounted on this panel.

Power Panel

Power-line connections to the base station are made at the power panel. Normal input is 117 volts, 50/60 Hz, single-phase; however, 240-volts, 50/60 Hz,

single-phase power may be applied through the use of auto-transformers available with the power panel. Overload protection for the system is provided by magnetic circuit breakers which also function as on-off power switches.

Internal Meter Panel

An internal meter panel is provided as an optional item. Complete metering of the transmitter and receiver, including monitoring of the RF output, is possible with this panel. Provision is also made for measuring the power line voltage and the line level on a 600-ohm telephone line when used. An *R1-R2* switch provides for metering of a second receiver.

A Complete Rack-Mounted Facility

A complete base station including receiver and accessories can be accommodated in a standard rack cabinet (Fig. 7). At the bottom of the rack is the power panel; above the power panel, a space is reserved for special or optional equipment covered by a blank panel. The third panel from the bottom is the line-termination panel as used for remote control. The fourth and sixth spaces are taken by receivers; the fifth panel is an accessory panel.

Above the first receiver is the exciter panel with the handset in the receptacle, followed by the internal meter panel and the antenna panel. The transmitter power supply is mounted above the transmitter, behind the external meter panel. The cooling air, moved by the transmitter blower, passes through filters mounted on the front and rear doors.

High-Power Systems

In addition to the medium-power systems described, high-power systems (Fig. 8) are also available. These systems are designed to provide 350 watts of continuous RF power in the low band and high band and 250 watts in the UHF band. In addition to an RF Amplifier and a high-voltage power supply, the same panels used in the medium-power systems are employed.

The RF amplifier is driven by a medium-power transmitter operating at reduced output power. The grid bias voltage supply and a regulated DC filament supply are contained in the amplifier. The high-voltage power supply provides 2000 volts DC, for the RF plate and a regulated DC voltage for the screen.

SUPER CONTROLFONE

The super controlfone is a compact base station designed for office use on, or beside, the desk and in any such application where space is at a premium. Its basic operation is similar to the super basefone, although it is more limited in scope. A typical system consists of a transmitter, receiver/exciter, terminal

panel or line termination panel, and power supply.

The transmitters (Fig. 9) are completely solid state except for an antenna switching relay in the UHF unit. RF power outputs range from 15 watts for the UHF transmitter and 30 watts in the high-band unit to 50 watts for the low-band unit. The multipliers raise the crystal frequency to the carrier frequency. The amplifiers provide power gain to the power amplifier which consists of three transistors connected in parallel. The low-band and high-band units utilize a solid-state antenna switch. Upon application of RF power from the transmitter, two diodes in the antenna switch provide automatic switching of the antenna from the receiver input to the transmitter output. An output filter for suppression of unwanted harmonics and a vswr bridge, to monitor the RF output, are incorporated in the transmitter. The UHF transmitter differs from the high-band transmitter mainly by the addition of a varactor multiplier stage.

In the super controlfone, the receiver, and the exciter are contained in the same panel. The oscillators and the modulator circuits are similar to the super basefone version. Plug-in connectors interconnect all units; the interconnecting cable with the plug is part of the terminal panel.

The super controlfone can also take advantage of the accessory circuits for

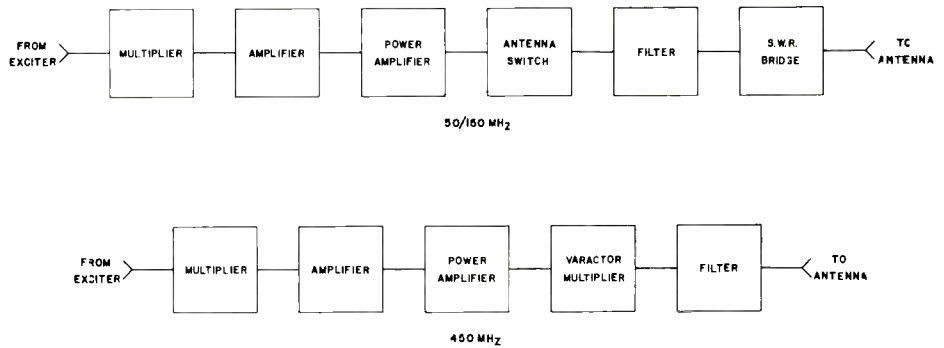

Fig. 9—Super controlfone transmitters.

the special applications previously described. Facilities are available for mounting various accessories, such as a three-minute time-out timer, quiet-channel unit, carrier-operated relay, or tone-operated relay, and also a line amplifier for feeding a repeater.

For installations, where the local-control unit (Fig. 10) is external to the super controlfone, a local test panel can be provided with the terminal panel. For remote control, the line-termination panel replaces the terminal panel. The operation of the line-termination panel is identical to that of the super basefone including local test facilities. It is equipped with the same cable and the same plugs as the terminal panel.

The power-supply panel contains the transmitter supply, the receiver supply, and an audio amplifier. The transmitter

supply delivers a regulated dc voltage to the transmitter. Current limiting provides circuit protection of the transmitter due to antenna mismatches. The receiver supply furnishes a regulated dc voltage to the receiver and to the audio-power amplifier as well as to the various accessories. The audio amplifier is capable of delivering 5 watts of audio power in the loudspeaker.

Fig. 11 shows a super controlfone with an integrated local-control unit.

CONCLUSIONS

The super basefone and super controlfone mobile communication systems provide effective, reliable and flexible service especially for UHF split-channel operation. Both systems lend themselves to the numerous modes of operation described in this paper.

Fig. 8—Front view of a high-power rack mounted system.

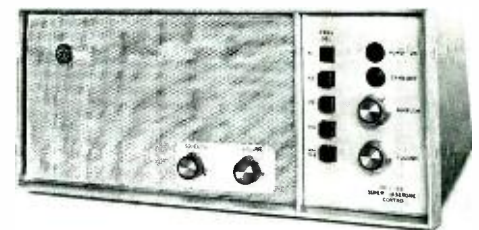
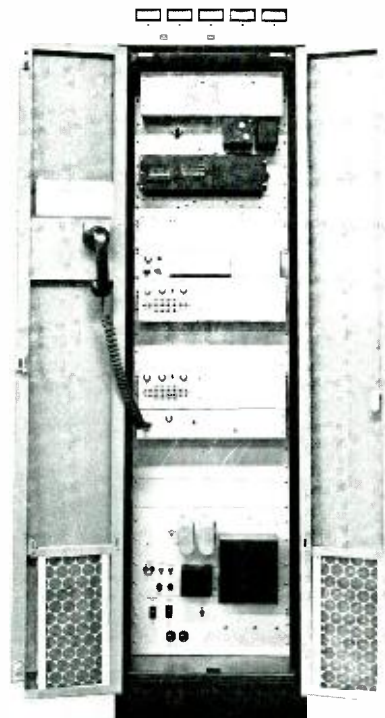

Fig. 10—Local control unit.

Fig. 11—Typical controlfone equipment in outdoor type cabinet housing.



SINGLE-SIDEBAND EQUIPMENT DESIGN—

Developing the STR-150 and SBA-1K

The design and development of STR-150 and SBA-1K equipments evolved from previous experience in single-sideband transceivers to provide modern modularized and solid-state circuitry. Advances made in passive and active electronic components have made possible the practical design of these equipments. This paper highlights the advantages of single-sideband and describes some earlier single-sideband equipments that preceded the STR-150 and SBA-1K. In addition, the design of the later equipments is covered in some detail. The Radiomarine and High-Frequency Engineering Design activity has been active in the design and development of single-sideband equipment since the early 1950's.

E. W. MAHLAND, Ldr.

*High Frequency and Radiomarine Communication Engineering
Broadcast and Communications Products Division, Meadow Lands, Pa.*

SINGLE-SIDEBAND COMMUNICATIONS began in 1914 when a controversy existed about the actual existence of the sidebands. In 1915, H. Arnold, of the U.S. Naval Radio Station, Arlington, Va., was able to pass one sideband and attenuate the other by properly adjusting and coupling to an antenna circuit. Concurrently, based on experimentation with AM, J. R. Carson of the American Telephone and Telegraph Company concluded the following:

- 1) Both sidebands are mirror images of each other.
- 2) The carrier contains no useful intelligence and is a reference for the sidebands.
- 3) The greatest amount of power was radiated by the carrier leaving the sidebands, containing the intelligence with considerably less power.

From these early experiments have grown the technical advantages and expanded use of single-sideband transmission.

EARLY SSB DEVELOPMENT

The necessity for long-distance telephone circuits furnished the incentive for rapid development of ssb carrier systems for wire transmission. Since 1918, ssb modulation has been almost universally applied to the carrier telephone systems. In 1923, probably the first high-powered ssb transmitter was placed in experimental service operating at 55 kHz¹. Frequency stability of the transmitter and receiver at this low frequency permitted operation with fully suppressed carrier.

Operation in the high-frequency band

Final manuscript received December 4, 1967.

(3 to 30 MHz) has presented a stability problem for narrow-band AFS (Audio Frequency Shift) necessitating the transmission of a pilot carrier.

Only recently, through the use of highly stable oven-controlled crystal oscillators and frequency synthesizers, has it been possible to eliminate the pilot carrier. Development of equipment of this type is limited due to high cost and small market (mainly military).

Use of the 3- to 30-MHz band results in lower atmospheric static and man-made radio noise; also, relatively small and inexpensive antennas can be used.

A single transmitter such as that used in the broadcast band which furnishes signals to a large number of receivers could not be replaced by a single-sideband transmitter due to the added complexity of single-sideband receivers. Obsolescence of existing receivers would also prohibit the use of ssb for this type of service as the state of the art exists today.

FCC REQUIREMENTS

Regulatory agencies have recently added

to their rules certain requirements pertaining to single-sideband equipment. In the United States, the Federal Communications Commission specifically limits the use of single-sideband to certain types of service (maritime-mobile, maritime-fixed, and a few other services).

The FCC also limits the frequencies within these services that may use ssb. In addition to the normal FCC requirements for AM, ssb equipment must also meet the following requirements for type acceptance:

- 1) A more stringent frequency stability;
- 2) Control the level of carrier suppression;
- 3) Capable of compatible AM transmission in the 2- to 3.5-MHz band;
- 4) Provide automatic limiting of power to a rated PEP level; and
- 5) Control intermodulation distortion.

Foreign countries have agencies similar to the FCC, but they tend to follow the CCIR (International Radio Consultative Committee) regulations which

Fig. 1—Peak effective voltage of AM transmitter signal.

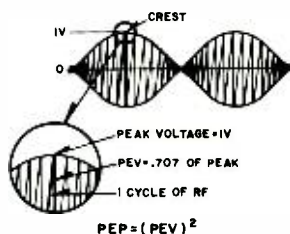
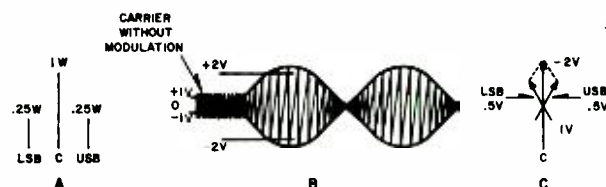

Fig. 2—Voltage analysis of an AM signal.



are, in general, similar to the FCC Rules and Regulations.

TECHNICAL ADVANTAGES OF SINGLE SIDEBAND

The two sidebands (upper and lower) contain identical information; and the same quality of intelligence can be obtained from either sideband, thus saving the power of one sideband. Since the carrier does not contain any intelligence and is used as a reference signal for receiver demodulation, it is possible to generate a carrier reference signal in the receiver. This eliminates the need for transmitting a carrier and, in turn, saves the carrier power.

To compare the relative performance of a single-sideband system to an amplitude-modulated system, the transmitter power ratings of the two systems should be considered first. SSB transmitters are rated in peak-effective-power (PEP) or as sometime phrased, peak-envelope-power. The AM transmitter is normally rated by mean carrier power (RMS). To have a basis of comparison, the AM transmitter mean-carrier-power rating can be converted to the SSB transmitter PEP power rating.

PEP is defined as the RMS power developed at the crest of the modulation envelope. For example, if the modulated output of an AM transmitter (Fig. 1) developed a peak voltage of 1 volt at the crest of the modulation envelope, the peak-effective-voltage (PEV) rating would be 0.707 volt and the PEP is 0.5 watt, assuming a resistance (R) of 1 ohm, ($PEP = \frac{(PEV)^2}{R}$); in other words, PEP and PEV are RMS values.

An AM transmitter rated at a carrier power of 1 watt (Fig. 2a) has a carrier power of 1 watt and 0.25 watt in each of the sidebands at 100% single-tone modulation; the composite-voltage envelope for this signal is shown in Fig. 2b. For simplicity a resistance of 1 ohm will be assumed for this analysis. Therefore, the 1-volt carrier produces 1 watt of carrier power. At 100% modulation the carrier and the sideband voltages add up to 2 volts (RMS).

EDWARD W. MAHLAND joined the Engineering Department of the Radiomarine Corporation in October 1945. Previous to his 3-year enlistment in the U.S. Navy he worked for the Sperry Gyroscope Company in their Bombsight Division. Mr. Mahland graduated from Bliss Electrical School in 1943 and Capitol Radio Engineering Institute in 1951. He completed the Alexander Hamilton Institute Executive Training Course in August of 1965. He has worked mainly in the design of receivers, direction finders, single-sideband diversity systems, facsimile and miscellaneous transistorized equipments. In 1961 he was appointed leader of the Radiomarine Communications Engineering group. Mr. Mahland is a senior member of the IEEE.

Each of the sidebands (Fig. 2c) produces 0.5 volt or 0.25 watts of power in each sideband ($0.25 = \frac{(0.5)^2}{1}$). Since there are 2 volts at the RMS high point on the modulation envelope, the PEP at this point is 4 watts ($4 = 2^2/1$). We can then state that for every watt of carrier power in the 100% modulated transmission there is 4 watts of PEP.

It is now possible to convert the carrier-power rating of an AM transmitter to a PEP rating, thus permitting a comparison to be made between SSB and AM transmitters. For example, if a SSB transmitter is rated at 4 watts PEP, it is capable of supplying 4 watts of RMS power. In the case of single-tone modulation, the transmitted SSB signal would have a PEV of 2 volts or 4 watts (Fig. 3a) assuming a resistance of 1 ohm. Fig. 3b compares the equivalent rated AM signal with the SSB signal; the AM and SSB signals both have the same PEV and PEP ratings. However, because of the distribution of power in the AM signal, the sideband power of the SSB signal is 8 times greater than the sideband power of the AM signal (Fig. 3c). In the case of the SSB signal, all of the power (4 watts) is contained in one sideband; and in the AM signal only 0.5 watts is contained in the sidebands (0.25 watts in each sideband).

A further comparison can be made by analyzing the overall effectiveness of the SSB and AM systems at the receivers. The inputs to the SSB and AM receivers are theoretically the same as that transmitted (Figs. 3a and 3b). It is also assumed that a gain of unity exists for the RF and IF stages of each receiver; the input to the demodulator of the AM receiver and the input to the last mixing stage of the SSB receiver are, again, theoretically the same as that transmitted. For SSB, after detection, the PEV is twice that of the AM case (Fig. 4). It can now be stated an SSB system produces a receiver audio output twice that of an AM system with an equivalent power rating. In addition, consider the signal-to-noise ratio of each receiver; it can be assumed that the thermal noise of each receiver is expressed by the following equation:

$$E^2 = 4 RKT\Delta H$$

where R is the equivalent noise resistance; K is Boltzmann's constant (1.38×10^{-23} joules per degrees Kelvin); T is absolute temperature in degrees Kelvin; ΔH is bandwidth in Hz; and E is RMS (root mean-square) noise voltage.

From the above formula, the noise equation for AM receivers is as follows:

$$E^2 = 4 RKT 6kHz$$

and the noise equation for SSB receivers is as follows:

$$E^2 = 4 RKT 3kHz$$

the SSB and AM systems at the receivers. The inputs to the SSB and AM receivers are theoretically the same as that transmitted (Figs. 3a and 3b).

It is also assumed that a gain of unity exists for the RF and IF stages of each receiver; the input to the demodulator of the AM receiver and the input to the last mixing stage of the SSB receiver are, again, theoretically the same as that transmitted.

For SSB, after detection, the PEV is twice that of the AM case (Fig. 4). It can now be stated an SSB system produces a receiver audio output twice that of an AM system with an equivalent power rating. In addition, consider the signal-to-noise ratio of each receiver; it can be assumed that the thermal noise of each receiver is expressed by the following equation:

Fig. 4—Single sideband detection (4a), and AM detection (4b).

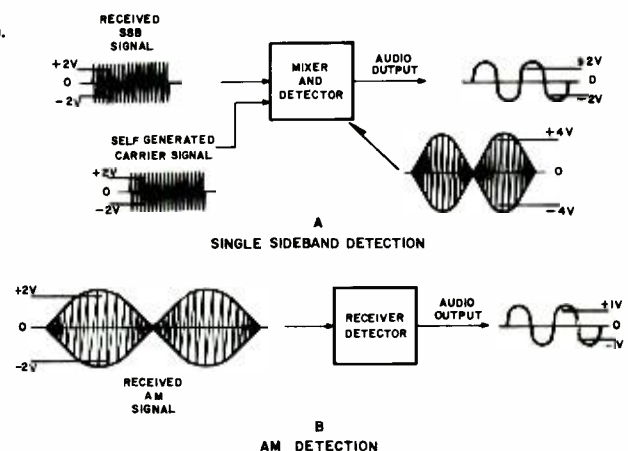
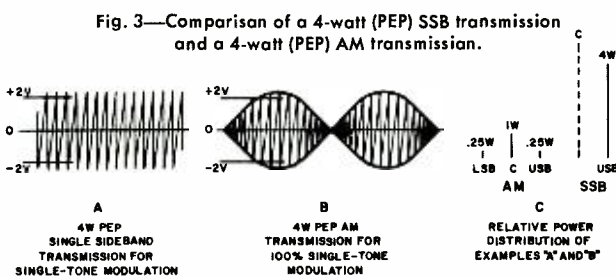

The noise ratio of AM to SSB noise can be expressed as follows:

$$\frac{\text{AM noise}}{\text{SSB noise}} = \left[\frac{4 RKT \text{ 6kHz}}{4 RKT \text{ 3kHz}} \right]^{1/2} = 1.414:1$$

The AM receiver has been shown to have 1.414 times greater noise than the SSB receiver because of the difference in bandwidths (6kHz vs. 3kHz). This advantage (1.414:1) and the audio output advantage (2:1) are equal to a total of 2.828. This equals a total gain of 9 dB or a power gain of 8 to 1 for the SSB system.

Numerous other factors enter into the technical advantages of single-sideband systems and have been summarized in a previous article.²

RCA'S EARLY SSB EQUIPMENTS

Basic operating principles of the STR-150 differ electrically from early equipments in the use of solid-state circuitry, and the use of novel methods developed to apply the basic principles of generating and detecting single-sideband signals.

SSB-1

The most important preliminary development for determining the best method of generating the SSB signal occurred on the first single-sideband equipment (SSB-1). There are two common methods to accomplish this objective—the filter method or the phasing method. Either method provides excellent performance when properly adjusted. The filter method, although more costly initially, is more stable in operation and is used almost exclusively in commercial equipment. The phasing method finds its greatest application among the radio amateurs. The SSB-1 radiotelephone circuitry and design details are discussed thoroughly in previous articles.^{3,4}

Fig. 5—Comparison of a 4-watt (PEP) AM transmission and a 4-watt (PEP) compatible AM Transmission.

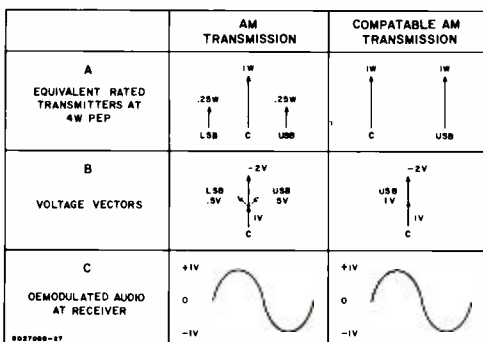

SSB-30M

The SSB-30M single-sideband mobile transmitter-receiver was developed next to satisfy the needs of the vehicular market; this 30-watt equipment was used in conjunction with the SSB-1 base station unit. The design and development of the SSB-30M are discussed in a previous article.⁵

SSB-1, Mark IIA

The second fixed-station SSB Radiotelephone developed by High-Frequency and Radiomarine Engineering was the SSB-1 Mark IIA. This unit has a higher output power (100 watts compared to 60 watts for the SSB-1), selectable upper or lower sidebands, improved frequency stability, lower intermodulation distortion, selective automatic-gain control, adjustable noise-limiter, and squelch circuits.

SSB-5

To provide greater flexibility, the SSB-5, a more compact and inexpensive unit was designed.² The SSB-5 provides mobile- or fixed-station operation with an output of 125 watts.

To supplement the SSB market, the SSB-5A was conceived to provide an accessory package for the SSB-5. These accessories consist of an electronic telephone coupler, voice-operated keyer, squelch, meter/VSWR indicator, AGC, and remote desk set selector. These early SSB equipments, discussed thus far, are all four-channel radiotelephones covering the frequency range of 3 to 15 MHz, in two bands: 3.0 to 6.7 MHz and 6.7 to 15 MHz.

ET-8063A

To provide higher power transmission to meet shipboard and point-to-point applications, the ET-8063A independent sideband transmitter was designed. It provides a high order of telephone or telegraph service with as many as 50 precisely controlled frequencies in five bands covering frequencies of 2 to 30 MHz.

IST-5K

A 5-kw transmitter (the IST-5K) was designed to satisfy the requirements of point-to-point communications for foreign and world-wide applications. The IST-5K provides remote control and other unique features making it suitable for commercial or government services. Reference can be made to a previous article⁶ for a comprehensive description of this equipment.

SSB-T3 & SSB-R3

Another SSB equipment built by the High Frequency and Radiomarine operation includes the SSB-T3 transmitter⁷

providing 20 kw of power from 4 to 30 MHz. This transmitter is normally used for inter-continental communications and provides single-sideband, double-sideband, or independent-sideband operation. The SSB-R3 single-sideband dual-diversity receiver⁷ provides the optimum in the reception of radio signals. This receiver covers 2 to 28 MHz, receives suppressed carrier, double sideband AM or PM, SSB telephone or telegraph, independent sideband telephone, and many other signal combinations.

THE STR-150 RADIOTELEPHONE

The STR-150 single-sideband transmitter was designed to satisfy the requirements of the foreign and domestic markets for many years to come; it provides compatible reception and transmission of AM signals in addition to its main function as a single-sideband transmitter. This feature permits use of the STR-150 in many areas equipped with AM radiotelephones. When these areas gradually convert to single-sideband, the STR-150 will be capable of supplying adequate communications in the future.

The equivalent transmission effectiveness of the STR-150 (150-watt PEP) equals that of a 1200-watt PEP AM system. For compatible AM transmission, half of the available power is contained in the carrier and the other half in the sideband. The compatible AM signal can be received with a conventional AM receiver, and it is a simple process to compare the compatible AM transmitter to the conventional AM transmitter (Fig. 5); note that both signals have the same PEP of 2 volts and, therefore, produce the same audio output voltage at the receiver. Assuming the same receiver audio outputs and signal-to-noise ratios (in the case when both signals are received in an AM receiver) both

Fig. 6—The STR-150 shown atop the SBA-1K linear power amplifier is also convenient for desk or table-top mounting.

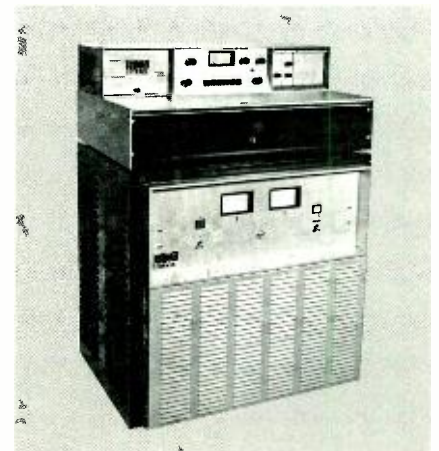

signals will have the same system effectiveness.

The STR-150 is packaged in a rugged, modernistic cabinet for desk or table-top mounting (shown atop the SBA-1K amplifier in Fig. 6). Special hardware is provided for greater security when mounted in a vessel or mobile carrier. Basically, the STR-150 is divided into five sections: the transmitter RF section, the transmitter receiver module section, the power supply section, the accessory section, and the control panel section.

All normal operational adjustments can be programmed for each of the six channels to provide maximum operating convenience previously unavailable in equipment of this class. After programming, the operator need only to depress the selected channel pushbutton, and the STR-150 does the rest automatically. The transmitting level, mode of transmission (full or suppressed carrier), simplex, or two-frequency simplex (transmit and receive on different frequencies) operation can be selected. Each channel can be programmed differently; and when required, the programming can be easily overridden.

The low-level circuitry for both the receiver and transmitter is readily accessible for test and adjustment via the unique swing-up modular design (Fig. 7). Individual circuit boards are glass epoxy for maximum reliability and are individually shielded to prevent interaction between critical circuits. For greater communications versatility, the STR-150 can be supplied with a wide range of modularized system accessories that fit into the basic cabinet.

When technical demands or building layout dictates, the STR-150 can be installed in any location and operated by its remote control unit (Fig. 8). It provides complete control, including

accessory operation, from any location up to 500 feet from the STR-150. Separate antennas can be supplied for each channel; antenna tuners are also available to properly couple to a 35-ft whip or wire antennas covering the frequencies of the STR-150 from 2 to 18.6 MHz.

STR-150 SYSTEM OPERATION

The transmitter (Fig. 9) is keyed manually or by the voice-operated-keying accessory; this transfers the antenna from receiver to transmitter through the antenna-relay contacts. The audio output from the handset microphone is applied to the compressor/sideband generator module. A novel compressor circuit utilizes a transistor as a shunt limiter to provide dynamic speech compression to maintain a ± 2 -dB output over a 14-dB input variation. A twin-diode balanced-modulator combines the 455-kHz oscillator module signal with the audio signal.

The resultant output, a double-sideband signal, with the 455-kHz carrier reduced greater than 30 dB is applied to the filter switching module. One upper and one lower mechanical sideband filter, plus an AM mechanical filter, are contained in this module. The sideband filters remove one sideband and reduce the carrier an additional 20 dB.

To provide compatible AM transmission, either sideband filter can be utilized and the carrier reinserted later at the proper level. The AM filter is required only in the receiver for the reception of AM signals.

The output of the filter switching module is amplified in the transmitter IF module for high-band or low-band operation. The carrier is also reinserted here for compatible AM transmission. Low-band operation is for channel frequencies between 2 and 8 MHz, and high-

band operation is for channel frequencies 8 to 18.6 MHz.

The use of a 2-MHz IF is necessary to provide the required separation between the channel oscillator and the output frequency to prevent spurious emissions. Frequencies above 8 MHz require a second balanced modulator to convert the low-frequency IF (455 kHz) to the high-frequency IF (2 MHz). The output of the 1545-kHz oscillator module is mixed with the 455-kHz IF signal to produce this 2-MHz IF signal.

A third balanced modulator in the low-level RF amplifier assembly converts either the 455-kHz IF or the 2.0-MHz IF signal to the desired transmitter channel frequency when mixed with the high-frequency oscillator signal.

The second and third balanced modulator circuits contain transistors, so connected to provide signal-ended inputs and outputs. This feature eliminates the necessity of complicated balanced circuitry and, in addition, provides a higher signal level than can be obtained from a diode type of modulator.

The high-frequency oscillator contains separate oscillator modules for each of the six channel frequencies. For low-band operation (2 to 8 MHz) the output is 455 kHz above the channel frequency, and for high-band operation (8 to 18.6 MHz) the output from the oscillator is 2 MHz above the channel frequency.

The intermediate-power amplifier tube increases the signal to the proper level to drive the final linear power amplifier tube for a power output of 150 watts PEP. Tubes were used at the time due to the unavailability of economically-priced transistors. In these two circuits, transistors were also incapable of meeting the intermodulation distortion specifications of the equipment at the required power output level. A π -section tuning and coupling network, for antenna matching, consists of a coil with taps, tuning, and loading capacitors which are switchable for each of the six channels; this network is contained in the power amplifier assembly.

The receiver is connected to the antenna through the antenna-relay contacts when the transmitting mode is completed. The received signal is amplified by one of the six RF amplifier modules. The signal is converted in the first mixer to 455 kHz or 2.0 MHz, depending on low- or high-band operation (2 to 8 MHz or 8 to 18.6 MHz) by mixing with the high-frequency oscillator output. In low-band operation, the 455-kHz IF is switched directly to the filter, and in high-band operation to a second mixer. The 1545-kHz oscillator is injected into

Fig. 7—Transmitter-receiver module section.

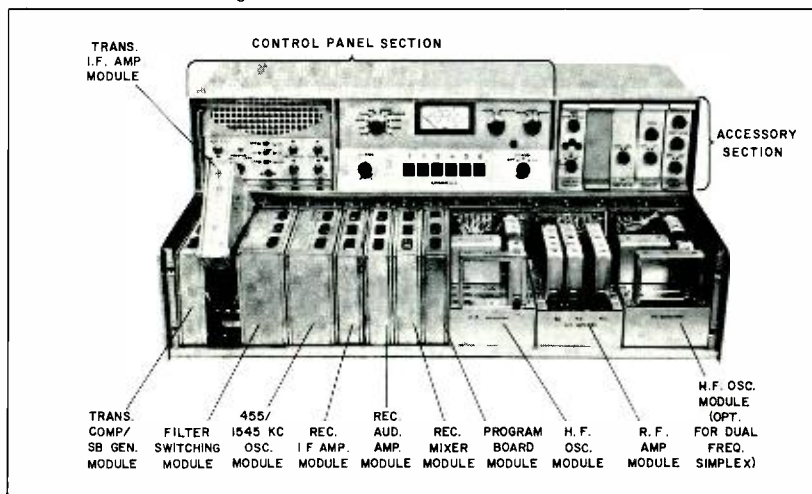

a second mixer and converts the 2.0-MHz IF signal to 455 kHz for injection into the filter module. The 2.0-MHz conversion is required to realize a minimum image rejection of 50 dB in the 8- to 18.6-MHz band.

The receiver IF signal to the filter switching module is properly routed through the desired filter. At the detector in the receiver IF amplifier module, a 455-kHz re-inserted signal is mixed with the IF signal to provide the proper carrier reference for demodulation. For an AM signal, the carrier "re-insert" signal is not necessary and is automatically disabled. The detected audio for AM or SSB is amplified in the receiver audio-amplifier module and applied to the handset ear-piece or speaker. The required switching functions are mainly accomplished by the use of solid-state devices controlled by the program board module. This results in the elimination of complicated and costly mechanical linkages and enhances the dependability of the system.

For two-frequency simplex a second crystal-controlled high-frequency oscillator, to accommodate six modules, can be added for the transmitter to permit transmission and reception on different frequencies.

Up to six channels can be accommodated to provide coverage on any six preselected frequencies in the 2- to 18.6-MHz range. The frequency range is covered in five bands (2 to 3 MHz, 3 to 5 MHz, 5 to 8 MHz, 8 to 13.2 MHz and 13.2 to 18.6 MHz). For any given frequency, modules are required for the transmitter, receiver and oscillator. With this arrangement maximum flexibility is provided, allowing all six channels to be in one band or any combination of bands to satisfy the required frequency coverage.

The primary operating controls provided are power switch, meter switch, channel-selection pushbuttons, receiver audio-volume control, ringer/speaker/handset switch and local/remote switch.

STR-150 ACCESSORIES

To satisfy the many requirements of the world-wide market, the following accessories were designed to complement the STR-150; all accessories can be normally mounted in the basic or remote control units:

- 1) Desk set selector for remote desk sets: permits transceiver operation from three remote-desk set extensions; it also provides intercom and monitoring capability for the equipment operator.
- 2) Squelch control: quiets receiver by a variable threshold squelch circuit.

- 3) CW modulator and keyer: permits connection of a telegraph key to the STR-150 for CW (A2J) communications.

- 4) Electronic telephone coupler: provides 2-wire connection of the STR-150 to normal telephone circuits.

- 5) Voice operated keyer: automatically energizes the STR-150 with voice signals.

Accessories not included in the basic STR-150 and providing further expansion of the SSB system are:

- 1) Remote control unit: provides complete operation of the STR-150 from a remote location permitting the STR-150 to be installed in the most desirable location.

- 2) AAT-150 automatic antenna tuner: provides a constant impedance match between the output of the STR-150 transmitter and a single dipole antenna for six pre-set channels.

- 3) CRM-X42B antenna coupler: permits the use of a 35-foot vertical antenna with the STR-150.

- 4) EDC-5A directional coupler: the EDC-5A is used to measure the VSWR of the transmitter and is connected in the coaxial line between the STR-150 and antenna coupler.

- 5) SRU-27B selective ringer: the selective ringer is connected to the ringer socket on the rear of the STR-150 unit and provides operating convenience similar to a land-line dial telephone system.

In many initial installations of the STR-150, the full complement of accessories and the use of all six channels will not be required. The simple *wire-in* feature of the channel modules and accessories permits the operator to expand facilities to meet future requirements.

The use of solid-state circuitry for the active circuits in the STR-150 greatly increases the dependability of the equipment. Maintenance and preventive maintenance time have also been greatly reduced.

THE SBA-1K LINEAR AMPLIFIER

The SBA-1K linear amplifier is capable of producing up to 1000 watts (PEP) output with a nominal input power drive of 100 watts (PEP).

The SBA-1K contains six channels covering the frequency range of 2 to 24 MHz. Each channel may be preset to the desired frequency without any limitations other than that of arranging the channels in ascending order. The same variable components are used to tune each channel by means of a solid-state servo circuit, thus conserving space and cost.

The SBA-1K linear amplifier is comprised of a large slide-type chassis for ease in channel setup and servicing. The high-voltage power supply chassis and the servo system circuits are located below the slide-type chassis. The circuitry is contained in a modern cabinet, matching the styling of the STR-150 (Fig. 6).

The 1000-watt (PEP) output is obtained from two parallel-connected grounded-grid triode amplifier tubes (8163's) operated at zero bias. This type of circuit configuration simplifies the design by eliminating the necessity of a bias supply and neutralization. The input presents a nominal 50-ohm impedance to the driver, requiring no input tuning over the 2- to 24-MHz frequency range.

The output tuning network is a π -L configuration to match an impedance of 50 ohms. This π -L network, plus a harmonic filter network, provides the necessary attenuation of harmonics and spurious to meet FCC requirements.

The high-voltage power circuitry supplies +2500 volts DC to the triodes from a solid-state compact rectifier connected in a bridge configuration. The low-voltage power transformer is required for

Fig. 8—Remote control unit.



filament voltage to the triodes; a second winding on this transformer supplies 24 volts AC, 24 volts DC, and a zener-regulated 22 volts DC for the servo system's sensing potentiometers, relays, and amplifiers.

Safety interlocks are provided to prevent exposure to high voltage when the cabinet is opened. A high-voltage overload relay is also provided to protect the triodes and power supply when nominal plate current is exceeded. Primary fuses are also provided for protection of other critical circuitry.

The π - and L-coil taps are changed by a motor-driven switch.

The solid-state servo system properly positions the servo motor-driven plate tuning and antenna coupling capacitors for the six channels. With this arrangement the six channels share the same two capacitors, reducing the need of 12 separate capacitors to only two for the six channels. The servo system operation is shown with the aid of the servo system block diagram (Fig. 10); three sensors are shown for simplicity. One senses the output position of the servo motor shaft; one senses the input position (mechanically set for a desired output sensor position); and another senses the difference (or error) between input and output positions. The input and output sensors convert the mechanical positions to electrical outputs. These two outputs are applied to the error sensor and compared for error. The error represents a voltage polarity and is applied to the control amplifier.

The control amplifier drives the servo motor in the desired direction until the output shaft is positioned to the desired manual setting of the input sensor. At this point, no error signal is generated, and the servo motor stops. Each of the six channels has its own sensor to position the tuning capacitor. The coupling

capacitor has an identical servo system.

A front-panel multimeter and switch are provided to monitor the voltages and currents. In addition, an RF ammeter is mounted, adjacent to the multimeter to simplify antenna matching and tuning.

SBA-1K COMPATIBILITY

The SBA-1K was designed mainly to be driven by the STR-150. The necessary circuitry is contained in these equipments for proper on/off control, channel selection and keying. A coaxial relay in the SBA-1K allows direct connection of the STR-150 to the antenna circuit for reduced power operation.

Modification kits are also supplied to connect other drivers, such as the SSB-5A, to control the SBA-1K, and to increase system power. With this level of output, short- or long-haul communications are made possible from fixed- or mobile-carrier locations.

An accessory item, the CRM-X45A automatic antenna tuner, can be used with the SBA-1K to automatically match any of six channels to a 35-ft vertical or long-wire antenna.

CONCLUSION

The majority of single-sideband equipment cover commercial and government markets both domestically and in foreign countries. The use of SSB is even expanding into the fixed and mobile services to provide more channels and dependable communications in the overcrowded HF radio spectrum.

The use of single sideband in the VHF and UHF bands presents a serious problem in obtaining adequate and inexpensive frequency stability in the order of 10^{-6} and 10^{-9} . A slight frequency change in the order of 50 Hz can make a single-sideband signal sound unnatural and, in many cases, unintelligible. An additional consideration in these bands is compati-

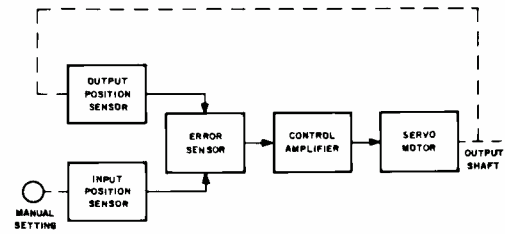

Fig. 10—Servo system block diagram.

ble operation with existing equipment using FM emission.

The STR-150 modular construction provided for expansion into more advanced equipment by repackaging the basic circuitry. The expansion of channel oscillator modules would permit operation in narrow-band frequency increments ($\sim 1\%$) as used for high-seas radiotelephone service.

Independent sideband operation could also be realized by the addition of separate audio channels. Two separate audio channels for the transmitter; one before the upper sideband filter, the other before the lower sideband filter would be required. The receiver would require separate audio channels after the upper and lower sideband filters.

ACKNOWLEDGEMENTS

The author wishes to acknowledge the efforts of R. T. Brankley and J. H. Peirce in the finalization of the design of the STR-150, and the efforts of B. Autry and R. Stevens for basic mechanical design and circuit development. Credit to R. P. McDonough and J. E. Rice for the successful completion of the SBA-1K and to R. G. Berge and C. E. Schneider for the initial design concepts.

REFERENCES

1. R. A. Heising, "Production of Single Sideband for Transatlantic Radio Telephony," *Proc. IRE* (Jun 1925) pp. 291-312.
2. E. W. Mahland and C. E. Schneider, "SSB Transceiver for Fixed or Mobile Applications," *RCA ENGINEER*, Vol. 7, No. 5, (Feb-Mar 1962) p. 15.
3. L. A. Laport and K. L. Neumann, "A New Low Power Single-Sideband Communications System," *RCA Review*, Vol. XVI, No. 4, (Dec 1955) p. 635.
4. N. L. Barlow, "The Design of Single-Sideband Radio Communications Equipment," *RCA ENGINEER*, Vol. 1, No. 6, (Apr-May 1956) p. 14.
5. C. E. Schneider, "The SSB-30M Single Sideband Transmitter-Receiver," *RCA ENGINEER*, Vol. 4, No. 1, (Jun-Jul 1958) p. 42.
6. B. Autry and L. Canto, "New 5-kW Transmitter Provides Versatile Communications," *RCA ENGINEER*, Vol. 7, No. 5, (Feb-Mar 1962) p. 12.
7. H. E. Goldstine, G. E. Hansell and R. E. Schock, "SSB Receiving and Transmitting Equipment for Point-to-Point Service on HF Radio Circuits," *Proc. IRE* (Dec 1956) pp. 1789-1794.

Fig. 9—Simplified block diagram of STR-150.

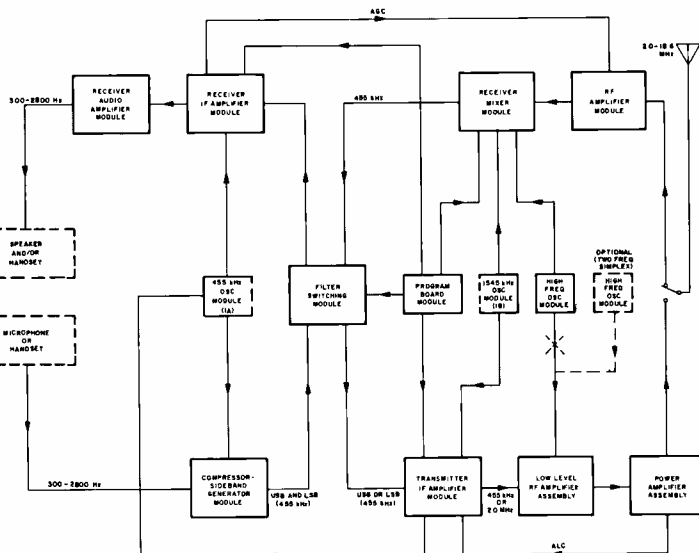

PLANNING 13-GHz TV RELAY SYSTEMS

In planning a microwave relay system, the user must consider propagation path characteristics as well as total system gain. This paper will review the criteria of system analysis and present the radio link designer with practical estimating tools. The user with his specific performance, reliability and cost goals may plan his system, confident of success.

E. J. FORBES, Ldr.

*Microwave and ITV Engineering
Broadcast and Communications Products Division
Camden, N. J.*

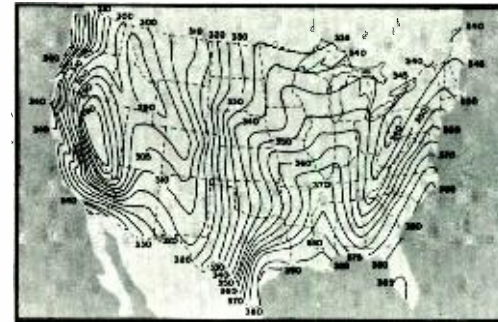

Fig. 1—Sea level refractivity typical for August (central radio propagation laboratory).

PROGRESSIVE CONGESTION is evident in the 6- to 7-GHz band where microwave transmission services are generally available. The broadcaster, educator, and community antenna relay operator must now find their places in the 12-GHz region. A review of the construction permits issued over recent years verifies this growth pattern. Fortunately, in the 10- to 13-GHz portion of the microwave spectrum, a series of bands are allocated by the FCC for varied types of transmission and service. They are:

Private Mobile	10.55 to 10.68 GHz
Common Carrier, Fixed	10.7 to 11.7 GHz
Common Carrier, Mobile	11.7 to 12.2 GHz
Operational Fixed	12.2 to 12.7 GHz
STL & Remote Pickup & Intercity	12.7 to 13.25 GHz
Community Antenna Relay	12.7 to 12.95 GHz

For some time, the operator has been hesitant to install a system in the 10- to 13-GHz band due to rain loss, and low effective system gain of available microwave relay equipment. These fears are no longer necessary. Propagation research in recent years indicates some doubt of previous precipitation estimates. To further enhance the picture, higher power klystrons are now commercially available along with receivers with low noise figures, with further reductions promised from tunnel-diode amplifier options. Solid-state equipment has evolved with superior operational reliability and low operating costs.

MICROWAVE PATH PLANNING FACTORS

The important factors which the system designer must consider in planning a microwave path are considered in the following text. Although these parameters are applicable to any of the microwave bands, the numerical values will be directed to the 10.5- to 13.5-GHz portion

Final manuscript received August 30, 1967.

of the spectrum. The literature is well stocked with authoritative papers on microwave transmission theory, and the reader seeking a comprehensive analysis may refer to some of the notable references.^{1,2,3,4} This paper is aimed at practical application of path planning.

Path Clearance

One of the major factors that the designer of the 12-GHz system must evaluate is path clearance. To predict the basic path transmission loss, it is necessary that the line-of-sight path have adequate clearance over terrain and structures both on true-path bearing and in its immediate vicinity. This clearance is generally assumed to be 60% of the first Fresnel zone (this is the imaginary ellipsoidal boundary which surrounds the ray between the transmitting and receiving antennas.) However, this is further complicated by the fact that, as the radio ray passes through the earth's atmosphere, it is refracted in a slight downward direction. To cope with this factor it is generally accepted practice to use straight radio rays and compensate for the refractive index of the atmosphere by using an "effective earth's radius." These principal factors are examined here in greater detail.

The effective earth's radius, K_r , is computed from:

$$K_r = \frac{1}{1 + r \, dn/dh}$$

where: dn/dh is the gradient of the refractive index with height, and r is the true earth radius (3960 miles).

The gradient can be computed from radio-meteorological charts. However, this has been reduced to a practical graphical process,⁵ using a sheet of linear graph paper and U.S.G.S. contour maps of the region. The procedure is to plot the path profile accounting for tree growth and man-made obstacles. With

the aid of such charts, the effect of the earth's bulge may be predicted for critical points on the path. A K factor frequently used to approximate the effective earth's bulge is $4/3$. However, Figs. 1 and 2 simplify this approach and yield an accurate estimate of the expected K value.

The lesser of the K factors is normally employed to arrive at the worst-case bulge condition. The bulge, B (in feet), is calculated from:

$$B = \frac{2/3 \, d_1 (D - d_1)}{K}$$

where d_1 is the distance to point in question (miles); D is the path length (miles); and K is the effective earth's radius factor.

As mentioned earlier, the antenna elevation must be raised further to allow for 0.6 first Fresnel zone clearance; this is a frequency sensitive factor and is given (in feet) by:

$$H_{0.6F} = 0.6 \sqrt{\frac{d_1 \lambda (D - d_1)}{D}} \text{ ft.}$$

where λ is the free space wavelength (ft); d_1 is the distance to point in question (ft); and D is the path length (ft).

To assist the designer, this too has been reproduced from the literature (Fig. 3). Although the analysis thus far has only established tower heights for the antennas, a system calculation employing these charts is considered later. The antenna size is as yet unknown; thus, the factors which influence it are examined.

Precipitation

Rainfall has been a prime consideration in microwave transmission in the 10- to 13-GHz band for a number of years. A new insight has been gained from the work of some authorities in the propagation study field and a number of elegant papers are available.^{6,7,8,9} An im-

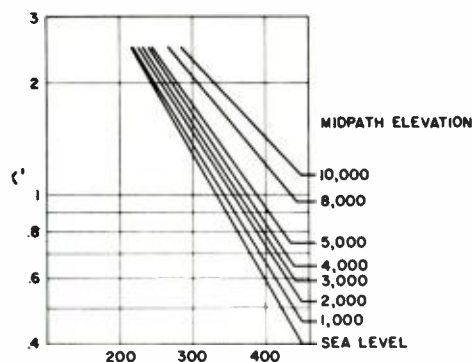

Fig. 2—Variation of K factor with refractivity and midpath elevation.

portant conclusion of Easterbrook and Turner is their recognition of the validity of Ryde's theoretical work.¹⁰

Measurements supported the maximum loss estimates in the very light-to-moderate rainfall rates (0.05 to 0.3 in./hr.). Data corresponding to intense storms (1 in./hr.) however, supported the minimum theoretical predictions. Thus, it can be concluded that the estimates of Hathaway & Evans, which used Ryde's work, deserve continued use. Furthermore their estimates may have a safety factor at the highest rain rates, where it is most needed.

An important extension of these contributions to the prediction of rain-outage time would be a series of distribution curves of excess rain loss for the various geographical regions of the USA. At the time of preparation of this paper, the statistical rainfall rates are not available in a readily useable form.

In general the principal considerations of 12-GHz transmission loss due to rainfall are the rate of fall (i.e., in./hr), the frequency of occurrence of intense storms, and the geographical area of the storm relative to the path. Since normal propagation variations (e.g., fading) are unlikely during such weather disturbances, the designer usually allows the total fade margin to be available for rain attenuation. It is however advisable, due to the attenuation of fog droplets, for the designer to allow about 1/4 dB margin

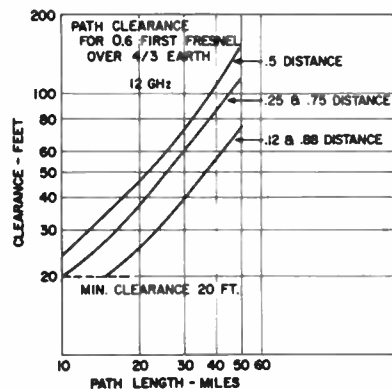

Fig. 3—Path clearance in feet versus length in miles.

per mile of path, if the path is subjected to severe fog (i.e., visibility 100 ft or less). Experience on a 12-GHz system with path lengths up to 48 miles, substantiates this loss effect. Furthermore, extreme fog condition concurrent to a severe rain storm (whose diameter is a large fraction of the path length) results in abnormal 'fades'. Consequently, in planning any system in this band, it is important to understand the meteorological characteristics of the area, as well as the usual topographical features. Appropriate margins may then realistically be allowed.

The effects of falling snow or hail attenuation are generally disregarded at 12 GHz; rain loss is the predominant factor. This is not the case of accumulation of ice or snow on antenna structures or feed horns which will be discussed later.

The work of Hathaway and Evans for prediction of rain attenuation at 11 GHz is considered accurate (although slightly pessimistic) for the meteorological data on which it was based, and this information has been presented in a useful and practical form. For these reasons the data is repeated in Fig. 4. Noting the geographical location of the system on the map of Fig. 4a, an alphabetical category of precipitation outage time is chosen for a fade margin of 40 dB. That category will select a curve in Fig. 4b. For the path length in question, depen-

dent upon the operating frequency, the curve will read out the outage time in hours for an 8700 hour year for a 40 dB fade margin. Note that the 0.01% outage time has been indexed. For fade margins other than 40 dB, Fig. 4c provides a multiplying factor to estimate the final outage time, hence the reliability.

It is apparent from Fig. 4 in general that paths in the Gulf Coast region should be limited to about 12 miles in the 11 GHz band, while approximately 8 miles at 13 GHz would be the maximum path length for 99.99% propagation reliability due to rain with 40 dB margin. These paths could be stretched to 37 to 27 miles, respectively, in the Pacific Northwest, in the 11- and 13-GHz bands, for the same performance. It is evident also that these path lengths may be significantly increased where the type of service rendered does not warrant such high reliability. For instance, an educator may be satisfied with 99.9%, having studied meteorological records over previous years, finding the predominance of storms occurring after dusk.

Fading

In almost any transmission system, an overall propagation reliability objective usually ranges from 99.9 to 99.99%. For moderate path lengths of 10 to 25 miles, a 40-dB fade margin and adherence to the clearance rules mentioned earlier would provide outage time of less than 1/2 hr per 8700-hr year, exclusive of precipitation. A guide for estimating path reliability is presented in Fig. 5. The longer adjacent paths would tend to have uncorrelated fading; hence, the outage time would accumulate. More seriously, a rain storm is much like a traveling cell, perhaps a few miles in diameter; consequently, the precipitation outage for a multiple-hop system must be treated as an accumulation of outages on the individual paths.

Therefore with a long-system objective of 99.95% reliability, the individual links (if there are more than five) must be designed with care. For instance, a 26-mile, 11-GHz path in Kansas is planned as part of a multi-repeater system. In this system design, 0.01%-outage-time/year would be assigned to

Fig. 4a—Contours of precipitation outage time for given path length (40-dB fade margin).

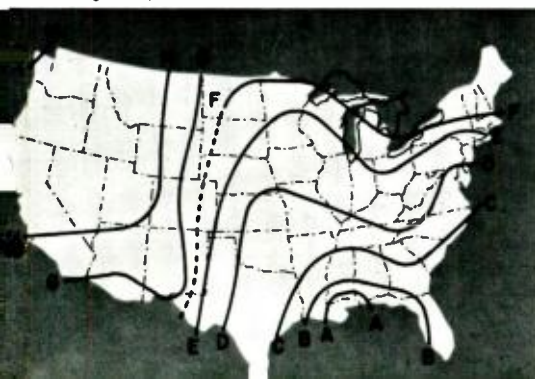

Fig. 4b—Expected precipitation outage time versus path length.

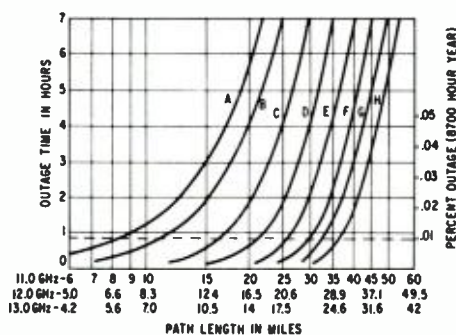
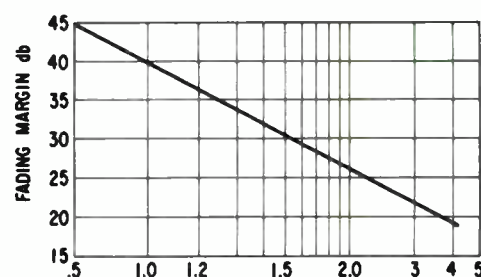

Fig. 4c—Outage time multiplier factor for fade margins other than 40 dB.



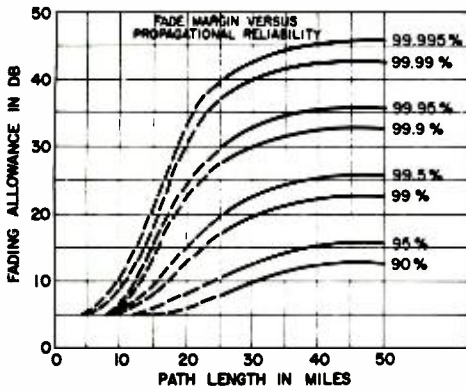

Fig. 5—Fading allowance versus path length in miles.

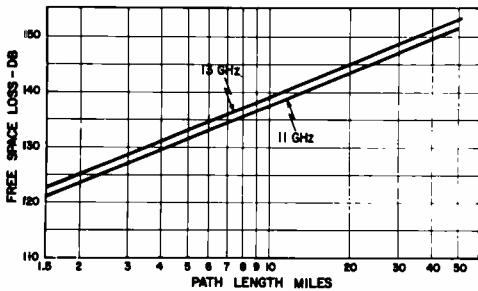

Fig. 6—Free space loss.

BAND GHz	GAIN-DB (RELATIVE TO ISOTROPIC)				
	DIAMETER (FEET)				
	2'	4'	6'	8'	10'
10.7 - 11.7	34.4	40.4	44	46	47.7
11.7 - 12.2	35.2	41.1	44.7	47	48
12.2 - 13.2	37.7	41.7	45.2	47.4	48.6

Fig. 7—Typical parabolic antenna gain.

that path to achieve an overall system goal of 99.95% due to rain. However, from the information developed, this one path at 26 miles would consume the entire system allocation. It is therefore necessary to go to two tandem paths; having done that, the total outage accrued by both would be predicted at 0.2 hr in 1 year—or a reliability of 99.99%.

Free-Space Loss

For the median free-space loss (in dB) between isotropic antennas, a graphical aid is provided in Fig. 6, calculated from

$$d = 37 + 20 \log f + 20 \log D$$

in which f is the carrier frequency (MHz), and D is the path length (miles).

Outside Plant

The various manufacturers of linearly polarized antennas quote typical gains of parabolic structures summarized in Fig. 7. The feeder loss ranges from 5.0 to 3.7 dB/100 ft for OFHC copper (WR75 feeder) in the 10- to 13-GHz spectrum and 3.5 to 4.4 dB/100 ft for equivalent material of elliptical cross-section.

It is not unusual to employ a periscope antenna system with a ground-mounted antenna and a plane reflector. A guide for the effective gain of various combinations of reflector and antenna sizes and separation is shown in Fig. 8. Such installation normally requires a radome on the antenna. This is principally to shed rain and protect the feedhorn against falling ice. The dry loss of antenna performance is typically 1 dB. The loss through a layer of water on a radome has been studied by Blevis.¹¹ For a rate of 3mm/hr, which would be experienced about 1% of the year, the water surface loss would be about 2 to 3 dB for a vertically aimed surface of typical aperture in still air. This will reduce with wind velocity, permitting us to ignore the effect. Radomes are also supplied with optional heating wires suitably oriented to the radiation plane.

There is some question of the desirability of melting dry snow accumulated

on such a radome; the loss through dry snow is not appreciable. Wet snow however has been reported to be significant, 4 to 16 dB/in. in this part of the spectrum.^{12,13} There is a danger that with the air temperature substantially below 30°F, the snow melts away from the radome surface forming a crown of wet snow with supporting top ice-crust. The principal advantage therefore is the shedding of rime or glaze ice. In any case, the choice of "heat" or "no heat" will depend on the region of the country and weather experience; heat is considered where ice storms are prevalent and there is a predominance of wet sticking snow.

Periscope Multipath

In choosing the antenna/reflector separation for a system, the designer must be cautious not to provide excessive clearance. Consider a *diminished* earth's radius—e.g. $\frac{2}{3}R$, with arbitrarily large path clearance done purely to have both-way facing reflectors at the same elevation at a repeater illustrated in Fig. 9. It is conceivable that under conditions of $\frac{2}{3}R$ the effective clearance will have increased and the ground-mounted antenna may have a less than grazing path to the distant reflector or tower-mounted antenna. This would present echo-distortion effects limited only by the directional characteristics of the ground antenna at 90° off-axis. This may be as low as 35 to 40 dB and would be intolerable in most systems.

System Design Example

We have now accumulated the tools for path evaluation and system design. We will consider a hypothetical path and verify transmission reliability. The radio equipment performance parameters are from the new RCA TVM-13 tv relay described in a companion paper.¹⁴ It is assumed that the system is located somewhere in Kansas; it is necessary that this path exhibit a reliability of 99.99% (outage 0.01%) since it is part of a long system.

First, a check is made for possible

Fig. 8—Periscope antenna gain.

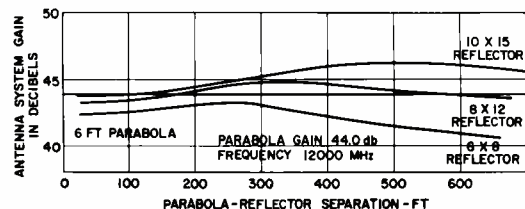
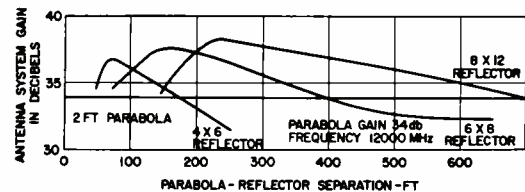
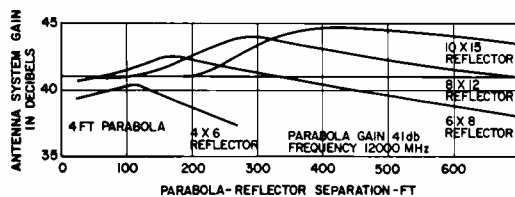



E. J. FORBES received the BSc(EE) from the University of Manitoba, Winnipeg, Canada in 1950. He then joined the Canadian General Electric Co. Ltd. in Toronto where he worked on various microwave equipments. In 1953, he joined RCA and became engaged in Advanced Development of Microwave Communication Circuits, 6000-MHz TWT application in particular. From 1954 to 1956, he was responsible for instrumentation, test link operation, and data analysis on an UHF and SHF troposcatter study. Since 1961 he has been responsible for the development of commercial microwave radio products with their auxiliary switching and supervisory equipments. Among the products were the RCA MM600-6, CW-60, CW-62 and TVM-6 and TVM-13. His project assignments included the Western Union Transcontinental System and most recently the Archdiocese of New York Instructional Television System.

fade margin control at the desired reliability. Curve D would be selected from Fig. 4a. A 17-mile path at 13 GHz would have a predicted outage of 0.02% with a fade margin of 40 dB. We are allowed 1/2 of that. Using the extrapolation to a 0.5 factor on Fig. 4c, a fade margin of at least 45 dB would be required.

Fig. 10 is a presentation of the path profile. Note that there is a tree growth on the prominent ridge near mid path. From the expression:

$$B = \frac{2/3 d_1 (D - d_1)}{K} \quad \text{feet}$$

using d_1 of 9.5 mi, D of 16 mi, and K of 1/3 and 0.86 (The 0.86 factor is found from the worst-case Kansas refractivity-contour of 360 (Fig. 1) and by entering this value into Fig. 2 for 1000 ft elevation.) We calculated

$$B_{0.86} = 48 \text{ feet.}$$

$$B_{1/3} = 32 \text{ feet.}$$

At 13 GHz, we find from Fig. 3, for 0.6 first Fresnel zone clearance:

$$H_{0.12D} = H_{0.8-D} = 20 \text{ ft}$$

$$H_{0.25D} = H_{0.75D} = 30 \text{ ft}$$

$$H_{0.5D} = 36 \text{ ft}$$

interpolating to 9.5 mi., $H_{0.5} = 34 \text{ ft}$.

These have been plotted on Fig. 10. The tower heights at A and B are chosen from the best graphical curve fit for an effective earth's radius K of 0.86. The heights are chosen to be equal and are 230 feet. (There may be a good reason to make them different e.g., local zoning, airport minimum clearance, and existing plants.)

The median path loss between A and B at 13 GHz from Fig. 6 is 143 dB. From Fig. 5, this requires a fade margin of 25 dB. We will use 45 dB, since precipitation is a controlling factor.

The principal parameters of the TVM-13 are:

Transmitter flange output	+30 dBm
Receiver threshold	-78 dBm
T + R branching loss in example	1 dB (total).
Permissible net path loss for 45 dB fade margin	-45 + 30 - (-78) - 1 = 62 dB
Net antenna gain (i.e., less feeder loss)	143 - 62 = 81 dB.

Assuming that WR75 feeder was used with tower mounted antenna and allowing an additional 25 feet at each end, the total feeder loss would be $(230 + 230 + 50) 3.7/100 = 19 \text{ dB}$. This would require $= (81 + 19) 2 = 50 \text{ dB}$ antenna—or each at least 12 ft in diameter, from Fig. 7.

Further, assuming that a periscope system is used and that the equivalent of 35 feet of feeder is required at each end to interface the radio equipment with the ground-mounted antennas (and account for flexible waveguide), the feeder loss would be:

$$(70) 3.7/100 = 2.6 \text{ dB}$$

Assuming that radomes at 1-dB loss each were planned, each antenna system would require:

$$(81 + 2 + 2.6) / 2 = 43 \text{ dB}$$

From Fig. 8, the 8x12 ft passives and the 4-foot diameter dishes would be selected.

From the standpoint of minimal tower loading and overall installed plant cost, the periscope system would be the choice of the designer.

CONCLUSION

Efforts of propagation analysts have substantiated the early precipitation loss predictions of Ryde and Hathaway and Evans. In this paper we have coupled and extended those estimates with a set of basic guides for 13-GHz path planning. With these rules and the recent relay equipment developments to higher system gain, the educator, business user, and CATV operator can confidently plan their systems in these bands. However, experience has indicated that ultimate performance satisfaction in the frequency range requires more than simple map knowledge. The terrain must be understood, including the history of localized intense rain storms and/or fog-trapping characteristics.

REFERENCES

1. *Point to Point Radio Relay Systems* published by RCA Service Co., Inc.
2. K. W. Pearson, "Method for the Prediction of the Fading Performance of a Multisection Microwave Link," *Proc. IEE*, Vol. 112, Number 7 (Jul. 1965).
3. Fagot & Magne, *Frequency Modulation Theory*, Pergamon Press.
4. K. Bullington, "Radio Propagation Fundamentals" *BSTJ* (May 1957).
5. "Tower Height Work Sheet for Microwave Systems" RCA form 3J4757.
6. S. D. Hathaway and H. W. Evans, "Radio Attenuation at 11 KMc and Implications Affecting Relay System Engineering," *BSTJ*, Vol. 38 (Jan. 1959).
7. D. Turner, B. J. Easterbrook, J. E. Golding, "Experimental Investigation into Radio Propagation at 11.0-11.5 Gc/s," *Proc. IEE*, Vol. 113, No. 9 (Sep. 1965).
8. G. E. Niebel and H. O. Dressel, "Propagation Studies in Millimeter-Wave Link Systems," *proc. IEEE*, Vol. 55, No. 4 (Apr. 1967).
9. B. J. Easterbrook and D. Turner, "Prediction of Attenuation by Rainfall in the 10.7-11.7 GHz Communication Band," *Proc. IEE*, Vol. 114, No. 5 (May 1967).
10. "The Attenuation and Radar Echoes Produced at Centimeter Wavelengths by Various Meteorological Phenomena" in *Meteorological Factor in Radiowave Propagation*; report of a Conference held April 8, 1946 at Royal Institution, London, pp. 169-188.
11. Dr. B. C. Blevis, "Rain Effects on Radomes and Antenna Reflectors", Conference on Large Steerable Aerials 1966, *Proc. IEEE*.
12. Y. Asami, "Microwave Propagation in Snowy Districts," The Research Institute of Applied Electricity, Hokkaido University, Sapporo, Japan.
13. Dr. B. C. Blevis, et al., "Measurements of Rainfall Attenuation at 8 and 15 GHz", *IEEE Transactions on Antennas and Propagation*, Vol. AP-15, No. 3, May 1967.
14. J. B. Bullock, "TVM-6/13 Microwave Relay Equipment," this issue.

Fig. 9—Periscope antenna system echo interference.

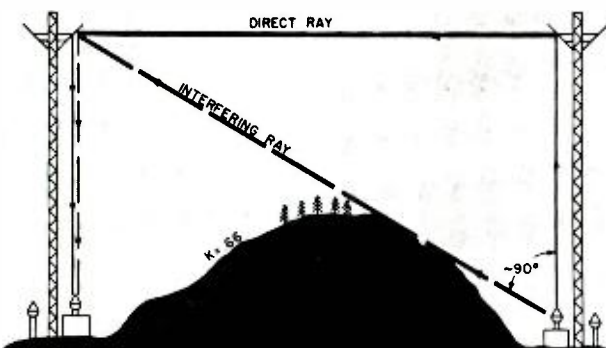
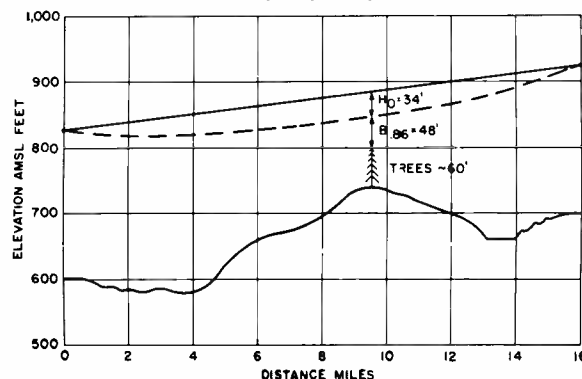

Fig. 10—Sample system profile.



TVM-6/13 MICROWAVE RELAY EQUIPMENT

The TVM is designed to provide point-to-point television relay service in the 5,925 to 7,425 GHz range under the nomenclature TVM-6A, and in the 10.5-13.25 GHz range under the nomenclature TVM-13A. Except for this frequency coverage and the required waveguide components, the TVM-6A and TVM-13A equipments are identical. EIA type WR-137 waveguide is used in the TVM-6A, and type WR-75 is used in the TVM-13A. The frequency coverage is detailed in Fig. 1.

J. B. BULLOCK

Microwave and TV Engineering

Broadcast and Communications Products Division, Camden, N.J.



Fig. 2—Transmitter control nest and RF chassis.

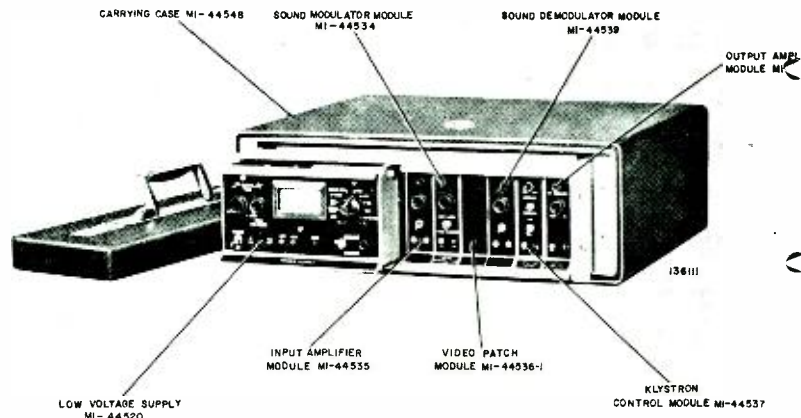
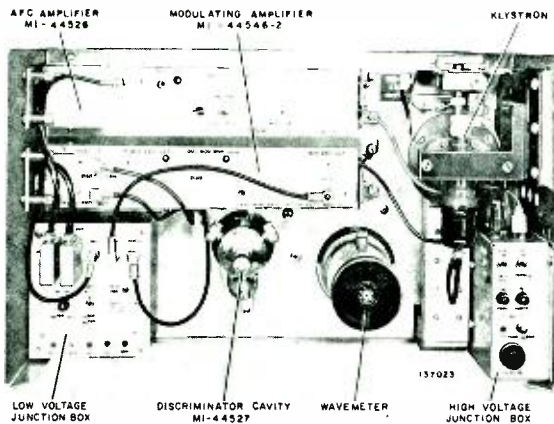

ALLOCATIONS	FREQUENCY BANDS			
	50	TO	50	50
COMMON CARRIER, FIXED & MOBILE	5.925	6.985		
COMMON CARRIER, FIXED & MOBILE	6.985	7.425		
STL, TV INTER CITY, TV REMOTE	6.985	7.425	11.25	13.25
BUSINESS RADIO	6.985	7.425		
COMMUNITY ANTENNA RELAY	6.985	7.425		
TVM-6 COVERAGE				
TRANSMITTER	5.925	7.425		
KLYSTRONS	5.925	7.425		
RECEIVER	5.925	7.425		
L.O. SOURCES	5.925	7.425		
TUNNEL DIODE AMP & MOUNT	5.925	7.425		
WR-137 WAVEGUIDE	5.925	7.425		
FILTERS	5.925	7.425		
BRANCHING CIRCULATOR	5.925	7.425		
TVM-13 COVERAGE				
TRANSMITTER			10.5	13.25
KLYSTRONS			10.5	13.25
RECEIVER			10.5	13.25
L.O. SOURCES			10.5	13.25
TUNNEL DIODE AMP & MOUNT			10.5	13.25
WR-75 WAVEGUIDE			10.5	13.25
FILTERS			10.5	13.25
BRANCHING CIRCULATOR			10.5	13.25

Fig. 1—TVM-6/13 frequency coverage.

THE TVM EQUIPMENT has been carefully planned to provide for several methods of mounting; internal subdivisions allow easy addition of accessory items not required in every installation but essential to others; and circuitry is designed to provide desirable controls and test points at convenient locations where they are needed.

PACKAGING

The TVM transmitter consists of a control nest and an RF chassis (Fig. 2). The control nest occupies 5¼ inches of rack space and provides a mounting for seven slide-in modules. The modules provide low voltage supply and metering, video, alarm, and sound-channel circuitry. Several are pictured in Fig. 3. The RF chassis occupies 10½ inches of rack space and is generally mounted directly above the control nest. This chassis houses the RF portion of the transmitter together with four removable subchassis. The subchassis provide klystron modulation and monitoring, AFC and high-voltage power supply circuitry. A typical subchassis is pictured in Fig. 4.

Final manuscript received August 30, 1967.



Fig. 3—Slide-in modules used in transmitter and receiver nests.

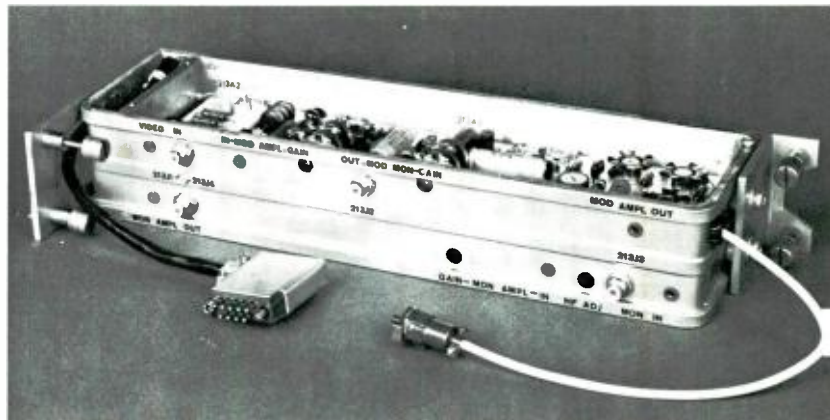

Fig. 4—Modulating amplifier.

The TVM receiver also consists of a control nest and an RF chassis (Fig. 5). Rack space and mounting of these units is identical to their counterparts in the transmitter. The seven slide-in modules (Fig. 3) in the nest provide for low-voltage supply and metering, video, alarm, and sound-channel circuitry. The RF chassis houses the RF portion of the receiver plus three subchassis containing IF, video and AFC circuitry.

In both the transmitter and receiver a control cable between the RF chassis and control nest carries power, metering, and intercom. Video is carried in a separate 75-ohm coax cable.

Portable Use

The TVM is readily adaptable to fixed-portable field use by mounting each of the four major chassis mentioned above in a field enclosure (Fig. 6). In such installations; the RF chassis are mounted on their respective antennas and longer cables are employed to connect each to its control nest. The design permits cable lengths up to 500 ft. The control nest in each case is kept at a sheltered location where all level controls and other operating adjustments are acces-

sible. The RF chassis enclosures are completely weather proof.

Another method is to rack-mount the control nest, while its associated RF chassis, in a field enclosure, is mounted on the antenna. This mounting is often favored in mobile vans or where an otherwise long run of waveguide to the antenna must be avoided.

TRANSMITTER

The transmitter obtains its RF power output from a reflex klystron, the only vacuum tube used in the entire equipment. The TVM-6A uses the VA-259 series of klystrons while the TVM-13A uses the VA-287 series. Both provide a nominal 1.5 watt RF output, are conduction cooled, and are operated with their beam electrode (which is the klystron body) at ground potential. The VA-259 klystron is shown in Fig. 2. A tuning motor on the RF chassis enables the klystron to be tuned remotely from a slide-in module in the transmitter control nest. Klystron-repeller voltage is also adjustable from the control nest tuning control.

The video signal to be relayed is brought in through the transmitter con-

trol nest to the input amplifier module slot, loops through the sound modulator slots, and is fed up the 75-ohm interconnecting coax cable to the modulating amplifier in the transmitter RF chassis (Fig. 7).

The input amplifier provides video gain, makes available an alternate 124-ohm balanced input, equalization for the interconnecting cable, a sawtooth test signal, input video-level metering, and an optional low-pass filter which is required if sound channels are to be transmitted.

The sound modulators provide for transmitting up to three program sound channels by FM subcarriers. The output of each sound modulator is simply bridged onto the video line. Both the frequency deviation and level of subcarrier from each sound modulator (s/m) are metered.

If only one sound modulator is used, the other two s/m slots may be used for a low-power indicator and a video-presence indicator. These units provide a warning of low RF power output and of low video level on either the input or monitor video lines. Note that the mon-

Fig. 5—TVM-6/13 receiver control nest and RF chassis.

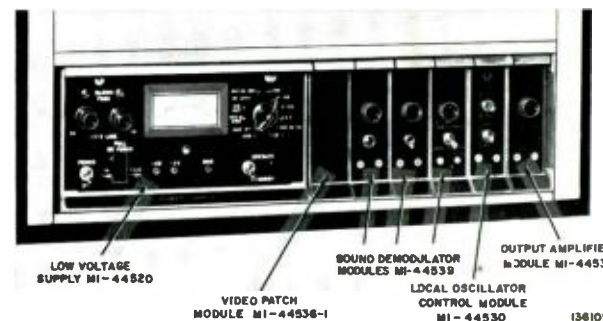
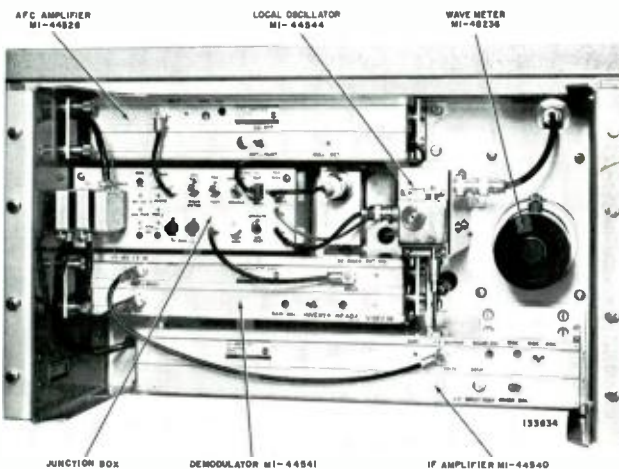



JOHN B. BULLOCK received the BSEE degree from North Carolina State College. Following wartime service in the U.S. Army Signal Corps, he worked at the Allen D. Cardwell Co. in Plainville, Connecticut on the design of VHF receivers and signal generators. He joined RCA in 1952 and assisted in the development of the TVM-1A microwave relay equipment and in the conversion of the TTR relay equipment for transmission of color television. He was the principal author of a systems concept for the TVM-1B, TVM-1C, and TVM-3. The TVM-3 was RCA's first TV relay equipment for use at 13 GHz. Most recently, he has been project engineer on the TVM-6 television relay equipment, and this effort has provided a solid-state equivalent to the TVM-1 system. Mr. Bullock has acquired graduate credits at Yale University and the University of Pennsylvania and is a licensed Professional Engineer in the State of New Jersey.

itor line also loops through the sound modulator slots (Fig. 7).

Still another alternate for any unused sound modulator slot is to use it for a sound demodulator bridging the video monitor line and thus providing a live monitor of the outgoing audio signal. This alternate is pictured in Fig. 2. Unused slots must be filled by a video patch module to complete continuity.

The modulating amplifier (Fig. 4) provides pre-emphasis and amplifies the video signal to a nominal 20-V p-p level, sufficient to modulate the klystron. A 75-ohm modulation monitoring point follows the last stage in the amplifier.

The pre-emphasis network included in the modulating amplifier is employed in accordance with Recommendation 405 of the CCIR for 525-line television. This

network reduces low-frequency amplitudes by 10 dB while allowing a 3.4-dB increase at high frequencies. Its use provides a minimum 3-to-1 improvement in differential phase and gain together with a 3.4-dB improvement in video signal-to-noise ratio, still keeping the transmitters p-p deviation within its rated 8 MHz.

The output of the modulating amplifier is fed to the klystron repeller through a video-test switch so that either video or a 60-Hz test signal may be selected for modulation of the klystron. The test voltage is normally set to produce a p-p frequency deviation of 8 MHz. In setting transmitter deviation, the switch is moved to the video position and the resulting level at the receiver or transmitter "off-air" monitor output should drop by 10 dB (3 to 1). The drop in

level is caused by the pre- and de-emphasis networks.

Alternatively the test modulation may be increased to produce about 50 MHz of p-p deviation, and at this level the RF and IF responses are "swept" and may be observed at various points throughout the transmitter and receiver.

The waveguide line following the klystron provides a *linearizer*, an RF power monitor, and a tunable *waveguide discriminator*. The linearizer is similar to a slide-screw tuner, and alters the RF loading on the klystron to improve modulation linearity. The RF power monitor provides a metered DC indication of power output and permits the use of an absorption wavemeter for measuring output frequency and deviation. The DC output of the discriminator is also metered, providing a means for its initial tuning. Final tuning optimizes linearity.

The DC output of the discriminator provides an input error voltage for the transmitter AFC. The AFC utilizes a stabilized DC amplifier whose output is connected to the klystron repeller and thus locks the klystron frequency to the discriminator.

The video output from the discriminator, after de-emphasis and amplification provides the "off-air" monitoring output and is fed down an interconnecting cable to the transmitter control nest. The output of the modulation monitor (Fig. 7) may be substituted for the discriminator output to provide a comparison of before and after modulation signals.

Following the discriminator in the transmitter output waveguide line is a ferrite isolator which protects the klystron load from poor external terminations, a bandpass filter used only in conjunction with RF multiplexing, and an RF switch. The RF switch is a solenoid-operated vane which in the "off" position inserts a minimum 50 dB attenuation and thus provides a "hot" standby ability. This reflective switch permits use of a circulator for main and standby connections to an antenna.

RECEIVER

The receiver employs a balanced waveguide mixer to minimize noise figure and assist in suppression of local oscillator radiation. Where RF multiplexing or image rejection are required, the signal input to the mixer is through a waveguide bandpass filter and isolator as the block diagram (Fig. 8) indicates. The filter is nominally 35 MHz wide at 3-dB points and provides over 80 dB of rejection at the image frequency.

Alternatively, the tunnel diode amplifier (TDA) may be mounted in the receiver front end to provide improvement in noise figure from 11 dB to below 7

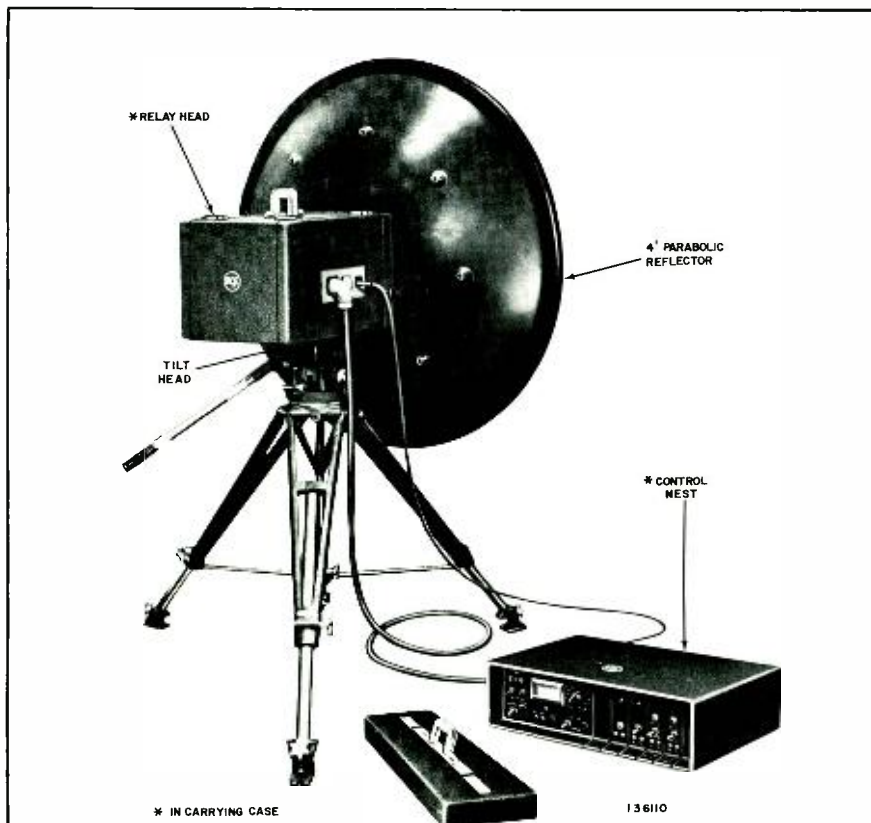

Fig. 6—TVM-6/13 receiver in portable mounting.

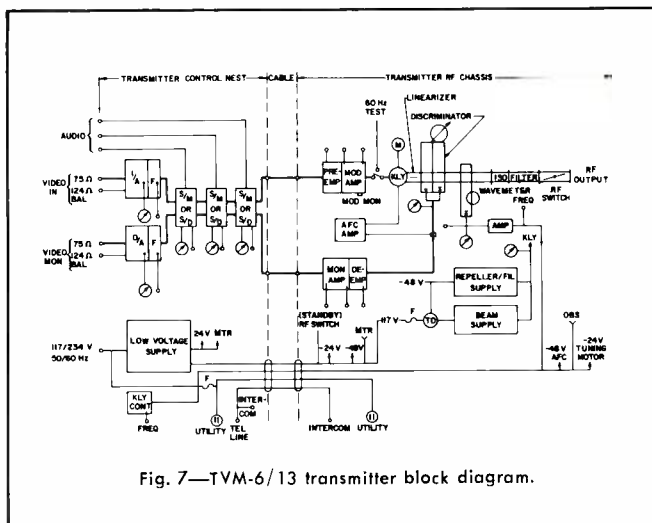

Fig. 7—TVM-6/13 transmitter block diagram.

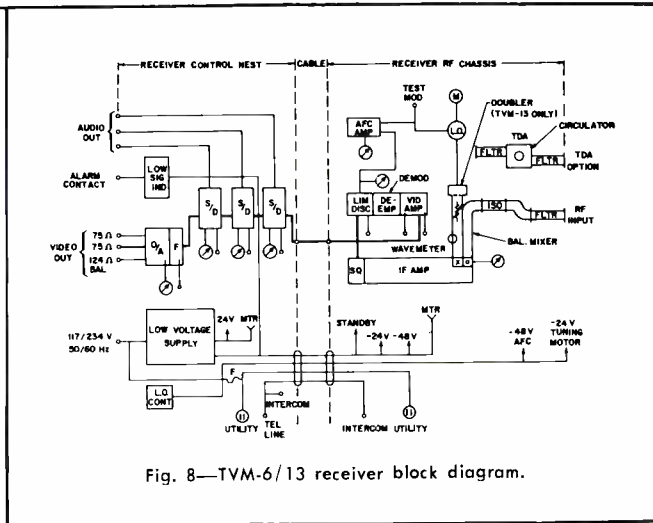

Fig. 8—TVM-6/13 receiver block diagram.

dB; or the mixer input may be a direct waveguide connection from the antenna.

The local oscillator signal, normally 70 MHz below the incoming signal frequency is fed to the mixer through a level-setting attenuator and a wavemeter mount. These items, actually part of the mixer plumbing, permit proper adjustment of oscillator level and frequency. The dc from the mixer crystals is metered to provide level and frequency indication and a check on crystal balance. Oscillator level at the mixer is 1 mW.

The local oscillator source in both the TVM-6A and TVM-13A receivers consists of a transistorized 1000-MHz oscillator followed by an X6 varactor multiplier. The oscillator is a cavity type with two modulating varactors and the multiplier mounted in the same package. Thus the 1-GHz signal is stepped up to a 6-GHz output capable of AFC and modulation. The oscillator frequency is adjusted manually by a tuning screw at the RF chassis or motor tuned remotely from the local oscillator module in the control nest.

Provision is made on the RF chassis for applying video-test modulation to the local oscillator by one varactor. When test modulation is applied, the incoming transmitter signal is not modulated but provides the beating oscillator, so that a resulting 70-MHz signal is furnished to the IF. In this way, video signals normally fed to the transmitter—multiburst, window, \sin^2 , etc.—may be applied to the receiver for test purposes.

The local oscillator is the only area of difference in the basic designs of the TVM-6A and TVM-13A receivers (Fig. 8). In the former, coverage of the 5.925- to 7.425-GHz band is provided by a family of three local-oscillator sources (Fig. 1); each supplies a nominal 5 mW by 50-ohm coaxial cable to the mixer. In the TVM-13A, the output of the local

oscillator source, again at 6 GHz, is taken by 50-ohm cable to a varactor frequency doubler. The doubler mounts on the mixer plumbing and provides the local oscillator signal in the required 12-GHz band. Local oscillator source output is 20 mW at 6 GHz and coverage of the 10.5 to 13.25 GHz band is provided by a family of three sources (Fig. 1). The doubler unit covers the full RF band of the receiver.

The 70-MHz IF amplifier mounts directly on the RF chassis mixer plumbing. This facilitates RF shielding and minimizes the possibility of pickup. This shielding is important since the receiver must operate at tv transmitter locations where potentially interfering signals will be quite strong. (Channel 3 is 60 to 66 MHz, channel 4 is 66 to 72 MHz, and channel 5 is 76 to 82 MHz.) The IF amplifier provides a maximum gain of about 90 dB. Operated with AGC, the amplifier provides a 75-ohm output of 0.8V RMS ± 1 dB for RF input levels ranging from -56 dBW to -106 dBW. An adjustable squelch circuit provides for reduction of the amplifier output to virtual zero (actually 65 dB) when incoming levels fall to about 6 dB above receiver threshold or lower. Receiver AGC is metered.

Following the IF amplifier, the signal is fed to the demodulator chassis, which contains limiter-discriminator, de-emphasis, and video amplifier boards. The output of the discriminator at a nominal 600-ohm video-impedance level is directly connected through the de-emphasis network to the video amplifier. The discriminator also provides a dc error voltage for the AFC amplifier.

The AFC amplifier is identical to the unit used in the transmitter. Its output is fed to a varactor in the local oscillator source and thus maintains the IF at discriminator center frequency.

In the typical case, the local oscillator frequency can be moved about ± 11

MHz by varactor bias changes. This is a good self-imposed limitation since it allows the local oscillator adequate range to hold any probable transmitter plus local oscillator drift, but does not allow enough movement for the AFC to lock onto an adjacent channel—normally 25 MHz away.

The video output of the demodulator is fed by 75-ohm coaxial cable to the control nest. There it is looped through the sound demodulator slots to the output amplifier slot. If these slots are not to be occupied, the video from the demodulator may be taken directly to the load.

Each sound demodulator module is nominally a TRF-FM receiver whose front end is tuned to its intended sound subcarrier. The unit contains several stages of amplification and limiting, a Schmidt trigger and pulse-counting discriminator, audio de-emphasis, and amplification. The audio output level is adjustable and is metered as is the received subcarrier level.

Finally, the output amplifier, which may also be used on the monitor line in the transmitter, provides two 75-ohm video outputs, one 124-ohm balanced output, equalization for the cable from the demodulator, video-output metering, and an optional filter to block sound subcarriers from the video outputs.

LOW-VOLTAGE SUPPLY

The low voltage supply is the major slide-in module used in both transmitter and receiver control nests. It provides a regulated -24 volts which powers all other nest-mounted modules, and a regulated -48 volts which powers most of the items mounted on the RF chassis. Sensing of the -48 volts is remoted to the RF chassis.

The low-voltage supply also provides for metering of equipment; all points noted earlier as being metered are wired

to a selector switch preceding the panel meter in this unit. The meter carries a dB scale to assist in audio-level setting, and all readings are calibrated to fall within one of two "green" areas when operation is normal. Line voltage, the -24V and -48V outputs, and AFC setup nulls are metered in both transmitter and receiver, in addition to the points listed earlier.

PERFORMANCE

Many operational features have already been indicated such as the transmitter sawtooth and sinewave test-modulation facilities (including the ability of the latter to provide an RF sweep), the signal-tracing test points, the metering, the before and after (off-air) klystron transmitter monitoring points, transmitter hot standby, the transmitter and receiver remote tuning, cable equalization, receiver preselection, tunnel-diode preamplifier, receiver squelch, receiver local-oscillator test modulation, and the local-oscillator drift limitation.

Field adjustment of the cable equalization in the transmitter's input amplifier is provided for by the observe (OBS) jack on the RF chassis (Fig. 7). This jack is brought down by a shielded lead to the frequency test point on the klystron control module. When the RF chassis and control nest are separated by some distance, the equalizer adjustment is made by applying a video sweep generator to the nest input terminals and connecting a video detector and termination at the RF-chassis end of the video cable. The detector output may be observed on a CRO at the nest, where the input amplifier is located, via this connection.

Another important feature is the provision for easy movement of the receiver local oscillator from its normal setting (70 MHz below the incoming signal) to a setting 70 MHz above the incoming

signal to avoid image interference. In the normal situation, the image frequency is 140 MHz below the desired signal, and a signal at such frequency will be as well received (if there is no preselection) as will the desired signal. If the local oscillator is shifted to 70 MHz above the desired signal, the image channel will now be 140 MHz above the desired signal, avoiding any lower interfering signal. Moving the local oscillator will, however, invert both the video signal and the AFC error. These can now immediately be righted by use of the INVERT switch on the demodulator and the reversal of the AFC output plug. If an interfering signal is also found on the upper image, RF preselection must be used. The ability to invert video and AFC separately also means that the receiver can be made compatible with the microwave transmission of competitive transmitters. An added stage in modulation would have inverted video without affecting AFC polarity. It is necessary to match video pre- and de-emphasis.

Still another characteristic of interest (Fig. 10) is the video signal-to-noise ratio at the receiver output. The RF level where the carrier power equals the receiver's own noise level (κ TBF) is indicated in Fig. 10, as is the level 10 dB above this. This latter point is designated as the receiver FM threshold. An FM receiver is rarely used below its threshold because of the rapid degradation in s/n which takes place with further decrease in RF input.

The weighted signal-to-noise ratio of 33 dB designated by EIA standard (RS-250A) as "outage" is below the FM threshold in the TVM-6/13 system. This means that with the TVM equipment a useful video signal is obtained during fading periods all the way down to the receiver threshold. Fade margins figured to threshold actually have an approxi-

mate 3.5 dB surplus (Fig. 10). If the TDA is used, the curves of Fig. 10 are raised by 4 dB and the receiver κ TBF and threshold levels are moved to the left by 4 dB. A plot of these effects would show the 33 dB s/n point to still lie below the new threshold, thus verifying the increased fade margin provided by the TDA.

RF Multiplexing

Provision has been made in the design of the TVM equipment for mounting up to four transmitters and/or receivers in a single rack with some space left for accessory equipment. These transmitters or receivers may then be multiplexed onto a common antenna or two antennas as required, using ferrite circulators (Fig. 9). All multiplexing elements are located within the transmitter or receiver concerned except for the circulator, and the entire assembly is kept within the confines of the cabinet rack.

CONCLUSIONS

The TVM microwave relay equipments possess many operational features, are capable of many system configurations, and provide performance in accord with today's most demanding requirements. System flexibility and performance achieved at 6 GHz with the TVM-6A are attained at 13 GHz with the TVM-13A. These facts reduce the choice of operating microwave channels to one of RF system engineering: choosing antenna gains, waveguide losses, and RF path losses. The choice of mountings provided will assist in locating transmitters and receivers advantageously so as to minimize waveguide losses and to take advantage of higher gain antenna configuration. Proper system engineering can thus provide excellent TV relay service at either 6 or 13 GHz.

Fig. 9—Waveguide assembly for a two-channel repeater.

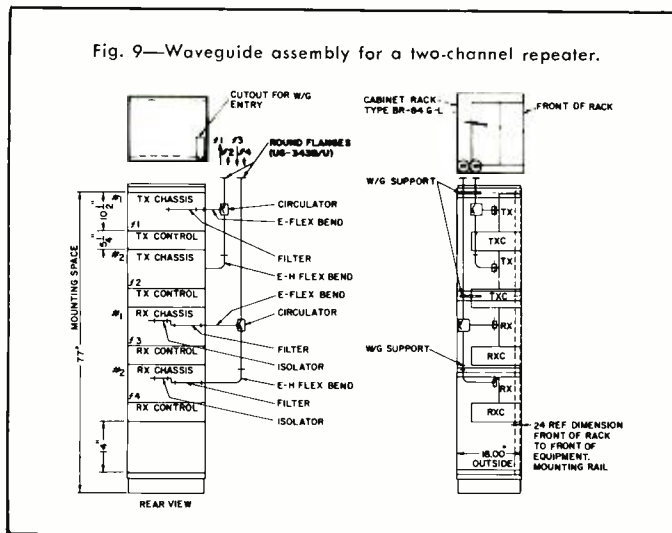
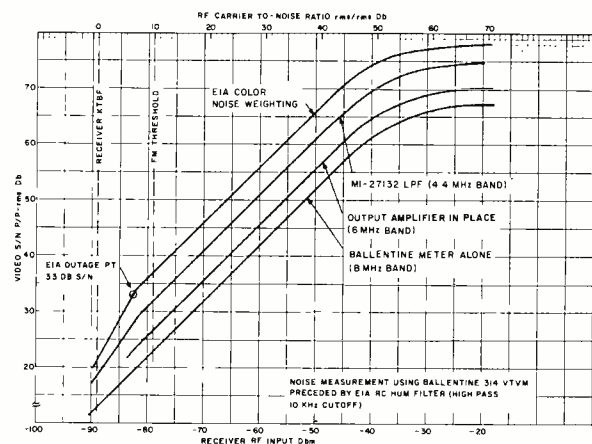

Fig. 10—Video signal-to-noise versus receiver RF power input.



IMPROVING AUTOMATIC SENSITIVITY PERFORMANCE IN COLOR TV FILM CAMERAS

Television film cameras which utilize vidicon pickup tubes have, for many years, included provisions for controlling camera sensitivity by adjustable target voltages. Attempts have been made to set up a closed-loop, automatic-control system by measuring the output video level and feeding back to the vidicon target a control signal which is developed from slight deviations from the desired output level. Performance of these simple systems has been less than satisfactory for several reasons. These problems are reviewed, and an updated solution is presented, which is proving to be more acceptable in current broadcast service.

ROBERT R. BROOKS

*Camera Engineering,
Broadcast and Communications Products Division,
Camden, N.J.*

AUTOMATIC CONTROL of video levels in television cameras has been accomplished with a degree of success for a number of years. The purpose of this paper is to describe a technique for improving camera performance when handling changes in average picture level and high- to low-density film transitions.

INTERPRETATION OF CHANGING SCENES

A film camera operator is charged with the responsibility of maintaining the best picture and preventing system overload without making his presence detectable to the viewer. Perfectly processed and exposed film is obviously the ideal—but seldom realizable—situation.

Final manuscript received April 11, 1967.

A skillful, alert operator can listen to the sound track and interpret scenes based on the script using the total of his life's experience. To do this automatically would obviously require a very large computer. The automatic control system, therefore, must be compared with an operator that has not previewed the film, and has been given very rudimentary instructions. Despite these limitations, a system has been devised that operates quite satisfactorily for most conditions of program material dynamics. The system was optimized by subjectively evaluating the picture as the final criterion, rather than establishing arbitrary speed of response and recovery times.

PREVIOUS SOLUTIONS TO THE PROBLEM

A skillful operator, interpreting scenes may elect not to increase the level of a particular scene. In so doing, he may avoid being caught by an overlevel signal. The automatic system, with its limited knowledge can act slowly to the reduced level signal and quickly to the overload condition, thereby simulating the least experienced operator. This has been accomplished in the past using automatic light control, automatic sensitivity, and automatic gain control. For any of these methods of control, program dynamics or the characteristics of the changing light image is of principle concern.

Consider a scene as reconstructed by the scanning system of the camera. Static information pertaining to the scene at a particular instant is available from one frame. Dynamic information, that of motion whether recurrent or random, must be obtained by observing several frames.

The dynamic information may be motion within the scene or a variation in intensity and area of illumination. It is the latter that causes the most consternation for the automatic control system. Since the area illuminated from scene to scene may be a random variable and at the same time the peak level may or may not change, the peak detector is the device that stores this information best for the automatic system. The peak detector in performance approaches what is sometimes called a "sample and hold" device.



R. R. BROOKS graduated from Hampton Institute in Virginia in 1952 receiving a BS in Industrial Arts and an ROTC commission. This was followed by two years of military service as an Army Artillery Communications Officer. He received the BSEE from Howard University in 1959 and as a participant on RCA's Graduate Study Program received an MSEE in 1964 from the University of Pennsylvania. In 1959, he joined the Industrial Electronics Products Division as a design and development engineer on the Optical Paper Flow Detector. Subsequent assignments included work in the Communication Systems Division where he was granted two patents for work on a digital synthesizer for the AN/ARC-104. Mr. Brooks has been associated with BCD camera engineering since 1964. His contributions since then have resulted in three patents for work on an encoder for color cameras and the system configuration discussed in this paper. He is now employed in developing electronically selective aperture equalization for color TV cameras.

A model of the peak detector commonly used is shown in Fig. 1. Switch S_1 is opened or closed depending on the previous value of E_c . The response to a positive input pulse E_a is an exponential with its rise time determined by R_1C if the new excitation is larger than the previous level. The response to a negative step is an exponential with a decay rate determined by R_2C .

The disadvantage that becomes obvious here is that if E_a drops suddenly after being at a particular high value, an error exists during the slow decay of E_a to E_c because E_c must decay to the new value of E_a before the switch will close. An adequate time constant of R_2C is required, however, for storing for several frames the information pertaining to short duration video peaks. Fig. 2 shows the response of a typical peak detector to a horizontal bar of light that flashes on once every five frames. Correction on a frame-to-frame basis is not desirable because program material may actually vary in level from frame to frame and low frequency video information would be removed.

The advantage of the peak detector is that almost immediate correction is available for abnormally high levels. Frame to frame correction has been avoided when signals like a flashing light are encountered. Practical examples of this

kind of signal would be flashing neon signs or firelight.

Consider the sudden application of nominal light level following an all-black scene. In the automatic mode, the absence of light results in maximum gain; maximum gain causes a nominal light level to be sensed as too large; the "too large" signal is "corrected" to a lower level; since the peak detector can respond to a new high rapidly, the over level signal will be of short duration. The recovery, however, will require a much longer period because the error voltage is being supplied by the decaying or reverse time constant of the peak detector that has been deliberately made long for proper holding of short duration signals. The timing diagram of Fig. 3 describes the action.

Improving the performance of the peak detector for holding on small area light images by increasing the decay time constant, therefore, will lengthen the recovery time and thus is not a solution.

PRESENT SOLUTION TO PROBLEM

By providing additional information to the automatic system, the transient that otherwise occurs following a dark-to-light scene change can be reduced or virtually eliminated and the effective holding of level for small picture area can

be improved to the extent that the problem is virtually eliminated.

The nature of the information would be whether or not light is present during a portion of a frame or during an entire frame. This knowledge can be translated into a voltage level that assumes one value during the absence of light whether it occurs for several frames, for a single frame, or for a portion of a frame or series of frames.

Now, if the necessary logic is employed, the gain or sensitivity loop can be opened during black so that gain or sensitivity can return to a quiescent preset value.

DETAILED DISCUSSION OF SOLUTION

The peak detected signal is filtered and the resultant direct voltage for small picture area is an average of the peak detected signal. Since the correct level is only indicated by the peaks, if there is any decay between scanned fields, the average error signal will be lower than it should be. An error signal that is less than it should be will result in increased gain or sensitivity. The result is that the output video amplitude will increase as the picture area decreases even though the incident peak light level may be constant.

By opening a switch S_2 , at the appropriate time, it is possible to increase

Fig. 1—Basic peak detector.

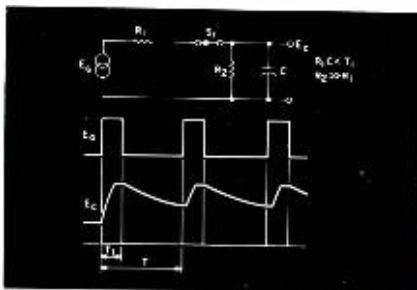

Fig. 2—Response of peak detector to a flashing horizontal bar of light.

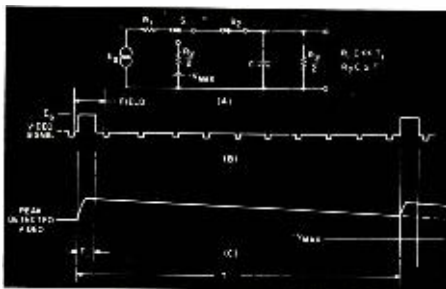

Fig. 3—Conventional loop response to suddenly applied light.

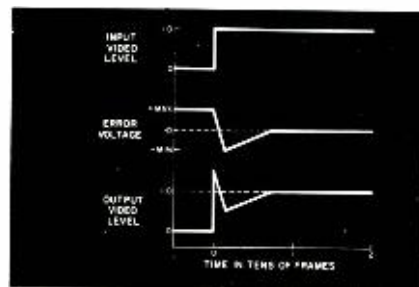

Fig. 4—Conventional automatic sensitivity control loop.

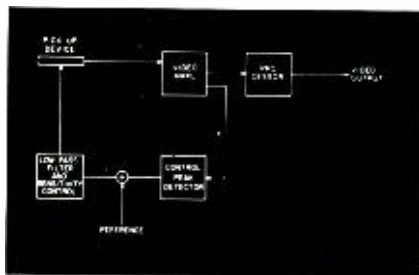

Fig. 5—Automatic sensitivity control loop with auto-present logic.

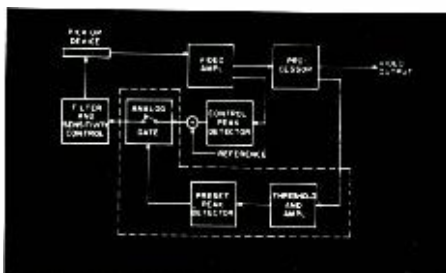
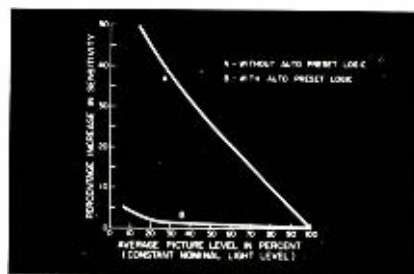

Fig. 6—Performance improvement realizable with auto-present logic when τ (decay) = 5 T.



the average error signal for small picture area or small average picture level. Consider a sensitivity or gain controlling system with an error voltage swing of $\pm V_{max}$ volts. When maximum sensitivity is required, the error voltage is $-V_{max}$ volts. When nominal sensitivity is required, the error voltage is zero. When minimum sensitivity is required, the error voltage is $+V_{max}$ volts.

The voltage derived from the peak detector of such a system for low average picture level high peak light level is shown in Fig. 2c. The peak detected signal reaches a new level if the input is larger than the previous level and persists for a time that is long relative to R_1C . When scanning the black portion of the field or black fields, V_e decays toward $-V_{max}$.

Recall that the loop would not be designed to respond to changes in level within a field but to average over several fields. A method for determining the average DC output of this peak detector is indicated in the Appendix.

Referring to Fig. 2, the principal idea of the innovations discussed in this paper involves "filling in the holes" for the detector. In this case, the aiming potential (the voltage to which the peak detector will decay) is $-V_{max}$. Switch S_2 of Fig. 2a is opened during the absence of the electronic signal that corresponds to the illuminated portion of the field. To hold level properly for horizontal images or images that will only be scanned for a small portion of the field in the vertical direction, switch S_2 is opened when the field has been black for several lines.

Now if switch S_2 is opened during the black portion of the field, the rate of decay of the error signal would be reduced because the aiming potential will have been reduced from $-V_{max}$ to zero.

The functional diagram for a conventional automatic gain or sensitivity control loop is shown in Fig. 4. The same loop with the preset logic circuits added is shown in Fig. 5. The addition to the control loop is enclosed in dotted lines. Switch S_2 is actually an analog gate that allows the proportional error signal to pass when the actual video signal level coming into the amplifier exceeds a predetermined level.

When the output video level exceeds the threshold, it is amplified and limited in a very high gain amplifier. The output of this amplifier is peak detected—or rectified—and is used to operate a switch called the analog gate in Fig. 5. The output of the detector is zero during the absence of video and is at some fixed level when video is present. The time constant of the detector is such that the analog gate is opened after the field has been black for several lines.

ADVANTAGES OF PRESENT SOLUTION

The introduction of the analog gate results in a truly remarkable improvement in the level-holding capability of the automatic system for small picture area and small average picture level. In fact, by proper selection of the time constant of the peak detector that operates the analog gate, the reaction time of the gate can be made to complement the sensitivity determining detector to the extent that the output video level will not increase even if the picture area is reduced to well below five percent. Another equally important advantage and the second of the two salient points of this paper is that during an all-black scene the detector is disconnected from the sensitivity determining part of the system. An automatic sensitivity control system, which is analogous to a position servo, requires zero error signal when the light level is correct. When the analog gate is opened, therefore, the sensitivity is returned to its nominal value. The sensitivity controlling portion of the system is designed with its own DC return such that when the error voltage is disconnected the input returns to zero. A trim adjustment should be added to permit presetting the sensitivity to precisely the desired value during black. Hence, the name "Auto Preset Logic" has been given to this innovation which has been incorporated in RCA's TK-27 color film camera and TK-22 monochrome film camera in conjunction with automatic target control. Graph B (Fig. 6) shows the improvement that can be realized with Auto Preset Logic for a control peak detector with a decay time constant of five fields. Line A shows how the sensitivity of the camera could increase with reduction in picture area for the conventional system. A peak-detector-decay time constant of five fields and a sensitivity range of ± 2 times nominal is used for illustration.

CONCLUSION

The preceding has described the problems involved in automatically controlling video levels in television film cameras and has justified the innovation of Auto Preset Logic in the RCA TK-22 and TK-27. There will continue to exist, however, scene sequences that will result in undesirable transients. The technique described here minimizes two heretofore inescapable problems: the overlevel video signal for light following black and the incompatibility of optimal average picture level performance, recovery time, and stability.

ACKNOWLEDGEMENT

The author wishes to acknowledge the support of the TV Camera Design group of the Broadcast and Communications Division of RCA, Camden, New Jersey.

APPENDIX

For the peak detector of Figure 1b,

$$E_c = E_c(o) + (E_o - E_c(o))(1 - e^{-t/R_1C}) \quad \text{for } E_o > E_c(o) \text{ and } R_1 \ll R_2 \quad (1)$$

$$E_c = E_c(o) + (E_o - E_c(o)) e^{-t/R_2C} \quad \text{for } E_o < E_c(o) \quad (2)$$

For the peak detector of Fig. 4,

$$V_e = (V_{max} + V_x) e^{-t/\tau} - V_{max}, \text{ when } t_1 < t \leq T \quad (3)$$

$$\text{and } V_e = V_x \text{ when } t < t_1, R_1C \ll t_1, \quad (4)$$

Then the average peak detected voltage is the area under the curve divided by the period T :

$$V_{AVG} = V_x (t_1/T) + \frac{1}{T} \int_0^{(T-t_1)} [(V_{max} + V_x) e^{-t/\tau} - V_{max}] dt \quad (5)$$

Evaluating the integral:

$$V_{AVG} = V_x (t_1/T) + (V_{max} + V_x) \frac{\tau}{T} [1 - e^{-\frac{(T-t_1)}{\tau}}] - V_{max} \frac{(T-t_1)}{T} \quad (6)$$

Adding a switch, S_2 , that will open at the correct time (during the black portion of the frame) will change the aiming potential from $-V_{max}$ to zero.

We would then have instead of Eq. 3,

$$V_e = V_x e^{-t/\tau} \quad \tau = \frac{R_2}{2} C \quad (7)$$

And the average over a field would be

$$V_{AVG} = V_x (t_1/T) + \frac{1}{T} \int_0^{(T-t_1)} V_x e^{-t/\tau} dt \quad (8)$$

$$V_{AVG} = V_x (t_1/T) + V_x (t_1/T) [1 - e^{-T-t_1/\tau}] \quad (9)$$

The graph of Fig. 6 is obtained in the following manner:

- 1) Let $T = 1.0$ FIELD
 $\tau = 5T$
 $V_x = 1.0$ volt
 $V_{max} = 2.0$ volts
 t varies from $0.05T$ to T
- 2) Use Eq. 6 for curve A. There is a direct relationship between sensitivity and error voltage. The voltage V_x has been selected as nominal at 1.0 volt since for nominal light level zero error voltage is desired, a reference voltage of 1.0 volt is subtracted from the result of Eq. 7. V_{max} has been assigned this value of 2.0. The normalized deviation in sensitivity for any error voltage ($V_{avg} - 1$) would be

$$\frac{V_{avg} - 1}{2}$$

- 3) Use Eq. 9 for curve B. Following the same reasoning, plot

$$\frac{V_{avg} - 1}{2}$$

RCA's TA-19 VIDEO PROCESSOR

The TA-19 video processor serves as a vital link in the TV chain as a signal corrector or purifier. Between the pick up and transmission of TV signals upwards of twelve or more detrimental effects such as distortions, transients, timing errors, and response variations are introduced at one point or another. This paper describes how the TA-19 functions to assure that the optimum signal is fed to the TV antenna.

L. J. BAUN

*Studio Equipment Engineering,
Broadcast and Communications
Products Division, Camden, N.J.*

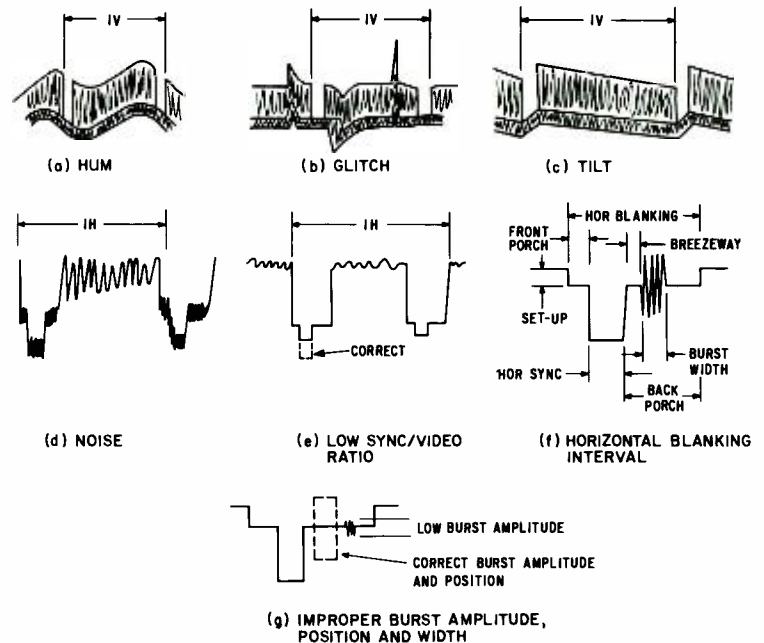

Fig. 1—Possible distortions of video waveforms.

BETWEEN the origination point and the transmitter antenna, video signals usually must pass through a complex distribution system which includes color encoders, distribution amplifiers, sync adders, switchers, special-effects generators, coax cables, microwave links, video recording and playback machines, and finally the transmitter. Although extreme care is taken to minimize signal deterioration in each equipment in the path, there are certain types of signal distortions and cumulative errors that can be present at the output of a system. For instance, frequency response, differential gain, and differential phase are common problems. Other distortions such as hum and glitches (transients) may be present that are not necessarily the fault of any video-controlling item in the path.

NEED FOR VIDEO PROCESSOR

Another problem arises from the fact that a "raw" signal from the television camera must have the sync, blanking, setup, color synchronizing burst, and encoded color information added separately at different points in the signal path. Each of these signals has its own set of timing and level adjustments and

is therefore a possible source of error. It may be quite difficult or inconvenient to correct these errors if they are discovered during "on air" time. This emphasizes the vital role of the video processor in correcting such errors prior to signal transmission.

COMMON SIGNAL DISTORTIONS

Following is a description of various types of signal distortion that can be present at the output of a video system:

- 1) **Sixty-Hz hum** appears in (Fig. 1a) and consists of common mode hum and unbalanced hum. Common-mode hum is characterized by the equal amplitude, and in-phase 60-Hz component on both the center conductor and shield of the video coax feed relative to the power line neutral. Two equipment locations operating on different unbalanced neutrals of the same power source is a common cause of this problem. Unbalanced hum is characterized by the fact that it is present only on the center conductor added to the video signal.
- 2) **Glitches and switching transients** (Fig. 1b), like hum, can be in the unbalanced or common mode. A frequent source of common-mode glitch input is the disturbance coupled to the power line feeds by power supply rectifiers. Switching transients sometimes look like the disturbances of

Fig. 1b; such disturbances are greatest when switching between video signals having widely different average picture levels.

- 3) **Vertical rate tilt** (Fig. 1c) is normally caused by one or more improper coupling time constants in the system.
- 4) **Noise and other spurious signals** (Fig. 1d) are present in practically all video handling systems and add noise to some degree. Microwave-link receivers operating with weak signals can generate relatively high noise levels. Video tape machines can add unwanted noise and spurious signals. Crosstalk from one signal path to another can be a problem.
- 5) **Video-to-sync ratio** effects can result from a condition of low-sync amplitude, although it is possible to have sync too high in amplitude. This effect can be caused by the misadjustment of the sync and/or video level, or caused by amplifier clipping, or severe differential gain.
- 6) **Pulse-timing errors and width distortions** result from delay variations in the multiple signal paths; for instance, there may be little or no front-porch interval. The various portions of the horizontal blanking interval that must be within certain specifications are shown in Fig. 1f.
- 7) **Frequency response, monochrome-chroma ratio and burst amplitude** are other variations in response; these can come from losses in coax cables, improperly adjusted video equipment, or the cumulative effect

Final manuscript received October 26, 1967.

of cascaded video systems. Besides causing overshoots or poor risetime characteristics, color saturation can be affected if the response characteristic in the color subcarrier region (3.58 MHz) is not correct since this causes an incorrect monochrome-chroma ratio. Error in response can also result in incorrect burst amplitude (Fig. 1g). It must be remembered that errors in the monochrome-chroma ratio and burst can also result from a mis-adjustment at the generating source.

- 8) The setup component of the signal can be incorrect at the output of a system. The setup component involves about 7.5% of the total video level used to maintain a separation between video black and back porch (blanking) level. This separation is helpful in the design of sync separators because it helps prevent noise and video information from reaching into the sync region.
- 9) Transmitter white-compression characteristics require compensation. Television transmitters frequently have substantial white compression (differential gain) as a result of their modulation characteristics. This is usually accompanied by high-differential phase distortion. Pre-compensation is necessary before the video signal is applied to the modulators.
- 10) Other problems are loss of signal, variations in signal levels, and improper burst phase, position, and width (Fig. 1g).

VIDEO PROCESSOR FUNCTIONS

It can be seen that there are many sources of error and distortion in a video

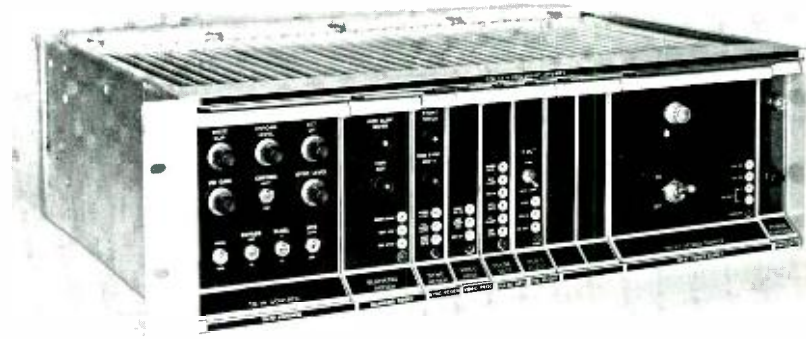

Fig. 2—The TA-19 video processor.

system. Problems can mount to even greater proportions when several complex video systems are tied together. Therefore, it is highly desirable that the video processor, a relatively small piece of equipment, can accept and correct these distortions within practical limits. In common practice, the video processor serves two other functions: 1) since all operational controls can be remote, it is used as a remote, signal-controlling device; and 2) it regenerates sync and

blanking pulses for use in timing at remote camera locations.

Another important consideration is that the processor errors added to a good signal are negligible; this in itself is one of the most difficult requirements to satisfy in the design.

The TA-19 video processor (Fig. 2) corrects for and/or minimizes the first nine itemized distortions listed above. In the future, video AGC and burst regeneration correction functions will be added;

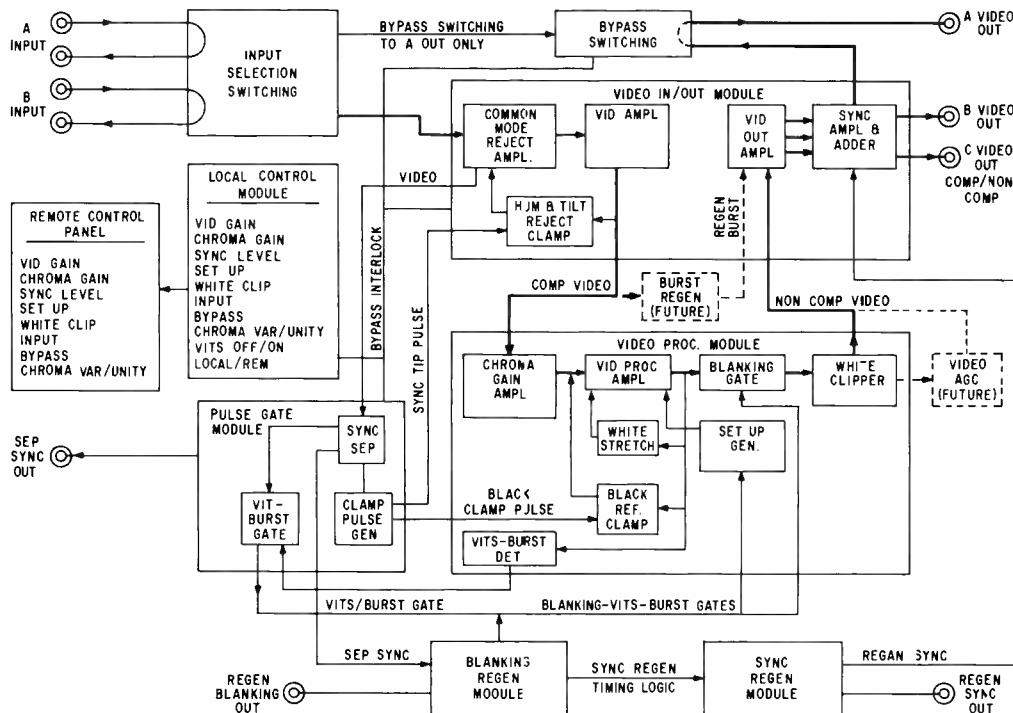

Fig. 3—Functional block diagram of the TA-19.



L. J. BAUN received the BSEE from Youngstown University in 1953 and came to RCA on the training program. He was subsequently assigned to the standards engineering group where he worked on component evaluation and reliability studies. He transferred to the Broadcast and Communications Products Division in 1955. Since this time, he has taken part in the development of the TM 21 color monitor, the TK 60 black and white TV camera, the WP 16 transistorized 280-volt supply, the TO 4 TV waveform monitor, and the TA 19 video-processing amplifier.

the modular construction scheme permits addition of these functions with minimum effect on the basic unit.

Besides meeting the basic functional requirements for a processor, the TA-19 provides three 75-ohm video-line drive outputs and a selection of two inputs. Through a bypass system, the video processor maintains an output video under severe conditions such as the removal of critical modules, the loss of power, or failure of the power supply. In the bypass mode, the input and output are connected together with no internal connection to the unit.

TA-19 DESIGN APPROACH

The basic module functions and interconnections of the TA-19 video processor are shown in Fig. 3; included are input selection, bypass switching and remote-control functions. The heavy lines indicate the path of the video signal through the system. The smaller blocks internal to the module block depict the major functions of that module and where in the signal path the particular functions are performed.

Following is a discussion of the methods used to correct the signal distortions itemized previously.

Hum, Tilt, Glitch, and Switching Transients

Hum and glitch distortions enter the TA-19 in the common mode and are eliminated by a common-mode-reject amplifier (differential amplifier) similar to that shown in Fig. 4. Hum and glitch

currents in the shield are sampled across R_s and coupled through $Q1$ to the emitter of $Q2$. The in-phase hum component on the center conductor is fed to the base of $Q2$. The gains to the output resistor R_o in the collector of $Q2$ are equal and opposite in phase, resulting in a cancellation of the unwanted common-mode hum and glitch distortions.

Video is present on the center conductor only and simply appears inverted at the collector of $Q2$. Input hum levels up to 10 volts peak-to-peak can be handled by the TA-19.

Tilt and unbalanced hum is eliminated by clamping which also minimizes the effect of switching transients. $Q2$ plus the block diagram portion of Fig. 4 illustrate the clamp function. Basically, clamp pulses act as sampling intervals while the video-signal level, which is trying to follow input variations, is compared to a fixed reference. Any differences between the video-output level and this reference constitute an error. This error signal is then amplified and fed back to the input transistor emitter $Q2$ in the proper phase to cancel the effect of the variations on the base. This action is similar to the common-mode cancellation discussed earlier. A constant (clamped) output level during the clamp-pulse time is therefore maintained independent of input level. Since tilt and hum represent fast rates of change, the clamp error system must react extremely fast to incoming variations. Also since high levels of hum (twice video level) may be encountered, the clamp error output must be capable of high level swings.

Extremely fast recovery clamps have the drawback of being susceptible to noise, since noise is also an error added to the signal. Clamp speed is usually measured by the number of horizontal lines needed for recovery from a step transition. Acceptable noise performance was obtained with a 20-line re-

covery from the step transition resulting from a switch between an all-white and all-black video signal.

This 20-line recovery time is sufficient to eliminate severe tilt and with the high-level capability of the error amplifier results in 26 dB hum rejection with up to 3-volts peak-to-peak hum at the input. A second and much slower clamp in the video process module eliminates the residual hum from the first clamp.

Frequency Response and Monochrome to Chroma Ratio

There are many causes for frequency response error and it is practically impossible to predict what the characteristic will be. For instance, it could be due to long coaxial cables or a simple RC rolloff. In a composite video signal there is only one piece of information that can be used to determine response problems, and this is the color-sync burst which should not vary with color-signal components.

Burst, however, may be mis-adjusted and if used as a response correction guide can cause response errors, overshoots, or deteriorated risetimes, and improper monochrome-to-chroma ratio (color saturation).

The TA-19 provides a variable high-frequency response centered around the color subcarrier (chroma) frequency (3.58 MHz). Referring to the circuit of Fig. 5, the chroma signal is developed across the trap in the emitter of $Q1$ and amplified in $Q2$. The gain of $Q2$ is made variable by controlling the emitter degeneration. The trap prevents the chroma information from passing through $Q1$ but allows the monochrome information to pass. The two signals are added in the collector circuits resulting in a video signal with variable chroma. The chroma variation is limited to ± 3 dB to minimize the possibility of adding extreme response errors if improper burst is used as a guide. A switch is

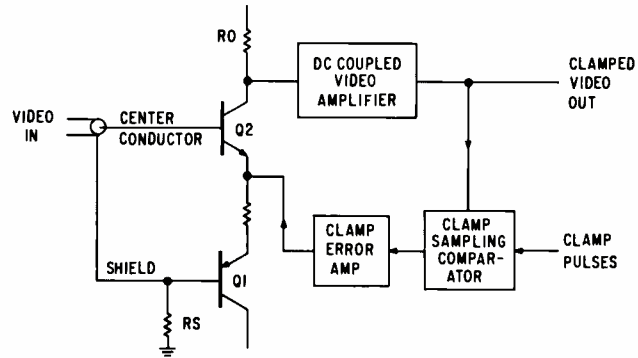

Fig. 4—Simplified block diagram of common-mode reject amplifier and clamp.

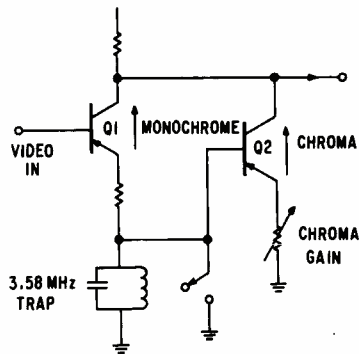

Fig. 5—Simplified chroma-gain control circuit.

also provided that shorts the trap. This puts the TA-19 in a specified flat response mode to be used as a reference independent of the chroma gain setting.

Noise and Other Spurious Signals

Generally, it is practically impossible to eliminate noise signal components in the video component of a television signal without destroying some video information. Noise components extending below video black level can be clipped out, but this is helpful only if they extend far enough below black to interfere with extraction of the synchronizing signals. It is possible to remove noise during the blanking interval however. In the TA-19, all information except color-sync burst is removed during the horizontal and vertical blanking interval. To do this, a blanking gate is necessary. This gate information is generated in the blanking regenerator module which uses sync separated from the incoming signal as a timing reference. Timing information from the blanking regenerator is used to completely generate a new sync signal. This noise-free sync is then added to the video signal at the output of the TA-19.

Fig. 6 illustrates the operation of the blanking gate; Fig. 6a is the basic circuit configuration, and Figs. 6b and 6c

are the equivalent circuit using switches. Fig. 6b shows the circuit during normal video transmission. The video driving circuit is low impedance with the blanking reference voltage level clamped to zero. When the blanking gate pulse arrives, the transistors saturate and the circuit changes to that of Fig. 6c. This approximates the ideal switch. As far as the output is concerned, it is switched from zero potential to zero potential and no extraneous pulse information results. Also the output is always at a very low-impedance level. This minimizes the coupling of transient gate pulse information from the transistor bases to the output. To allow passage of burst, a gate is added that returns the circuit to the condition of Fig. 6b during burst interval.

Noise also causes a width modulation on the leading and trailing edge of the sync pulses. This can cause timing "jitter" problems if sync is used for timing later in the system. This problem is minimized in the TA-19 by locking the new sync to the incoming sync in an AFC loop with sufficient storage or "flywheel" characteristic to average out the input timing variations due to noise.

Pulse Width and Timing Corrections

In the blanking and sync regenerator system, blanking, width, front porch width, and sync width are made adjustable and can be set to specifications. The widths are independent of the incoming signal variations.

Setup Correction

Setup, which is actually a small amount of blanking signal added to the video, is taken from the blanking regenerator, made variable, and added to the video in the video process module.

Video to Sync Ratio

As stated previously, regenerated sync is added to the output video. Before its addition it is made adjustable in level. A video gain control is provided in the video in/out module. Both controls are

used to set the proper ratio. The output sync level is independent of input sync level.

Transmitter Correction

The TA-19 contains white stretch circuits to compensate for the severe white compression in transmitters. The white-stretch circuit is basically a non-linear amplifier. Variable stretch up to 6 dB differential gain is possible in three steps from grey to white. Differential phase can also be adjusted in each of these steps in amounts depending on the setting of each differential gain adjustment.

Loss of Signal

A loss of signal is detected by the loss of separated sync. Under this condition, the TA-19 sync and blanking system automatically switch to a free-running mode. Thus sync and setup are maintained at the video outputs. The frequency accuracy in the free run mode is sufficient to maintain monitor or receiver lock-in.

FUTURE TA-19 FUNCTIONS

Video AGC

This will maintain proper output video level independent of input level.

Burst Regeneration

Here burst will be completely regenerated. The new burst will be locked to incoming burst and be variable in amplitude, phase, width, and position. All characteristics of the regenerated burst except phase will be independent of the input burst.

CONCLUSION

In the RCA TA-19 design, an attempt was made to correct the most serious video signal problems encountered by the broadcaster. The design also included means to insure a signal output for a variety of fault conditions including power failure and loss of input signal. Also, the requirement for adding negligible deterioration to a good signal has been met.

Fig. 6—Operation of blanking gate.

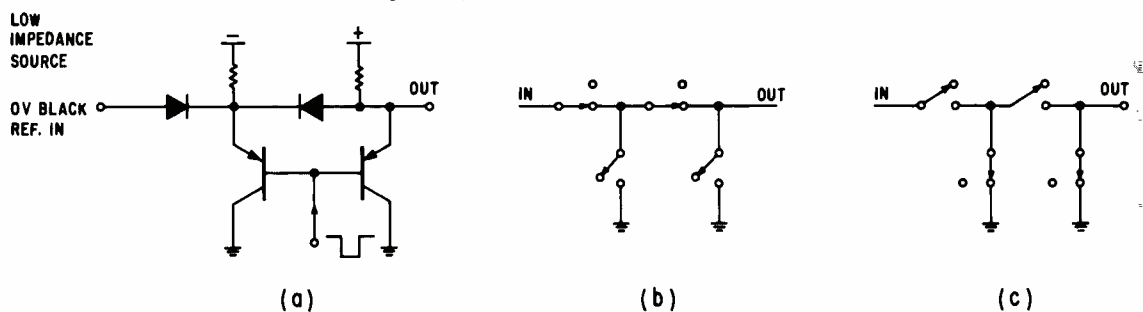

SPECTRUM ANALYSIS OF MAGNETIC VIDEO RECORDER FM SYSTEM

This paper discusses the spectrum energy distribution characteristics of a magnetic video recorder FM system, analyzes the level of spurious frequencies generated in the recording and signal recovery process, and discusses factors that affect the signal-to-noise ratio of the played back video signal.

KOICHI SADASHIGE and JAMES B. VAN ANDA

*Broadcast and Communications Products Division,
Camden, N. J.*

ALMOST ANY form of engineering accomplishment can be considered as the best compromise between the ideal approach and the limitations imposed by the state-of-the-art. The FM system adapted to the contemporary color-television magnetic recorder is a good example of such a compromise. The FM technique used in these recorders has a number of characteristics not normally found in the conventional FM systems used in VHF/UHF communications and radio broadcasting. In recorder applications, the frequency difference between the carrier frequency and the highest frequency of the modulating waveform is relatively small. Because of this, the sideband components occupy the entire spectrum from zero frequency to almost twice the carrier frequency.

CHARACTERISTICS OF TELEVISION VIDEO SIGNALS

The available bandwidth for a TV video signal in the United States is typically 4.5 MHz. However, the spectral energy in the typical video signal produced by

Final manuscript received November 17, 1967.

Fig. 1—Typical spectrum energy distribution of a television signal.

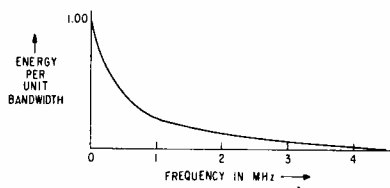
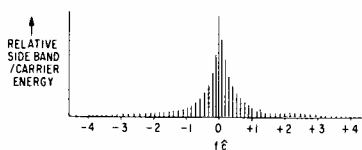

Fig. 2—Spectrum energy distribution of FM signal.



a monochrome television camera is not evenly distributed. Rather, the energy is a maximum at the low end of the spectrum, and decreases practically to zero at the upper limit of the bandwidth as shown in Fig. 1. This distribution is a result of two factors: first, the principal processes through which the video signal is generated, i.e., optical imaging, image-storage action within the photo-sensitive layer of the camera tube, and the finite size of the scanning beam of a television camera tube, act as a series of cascaded low-pass filters and attenuate high-frequency components; second, the contrast ratio decreases with decreasing object, or pattern, size as seen by a television camera.

The energy of the video signal is contained as spectrum lines spaced by the horizontal line frequency. Transformation of such a signal into a frequency modulated spectra shows extreme concentration of energy around the FM carrier and a very rapid decrease of energy as the spectrum moves from the carrier frequency. This condition, depicted in Table I and Fig. 2, facilitates the handling of this type of FM signal.

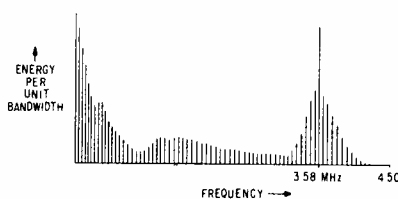
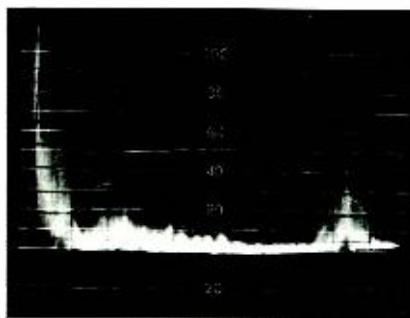

Fig. 3—Spectral energy distribution of a typical on-air color television signal.

COLOR SUBCARRIER AND ITS INFLUENCE ON FM SPECTRUM

The brightness information, or the luminance component, of the encoded color-television signal follows the general spectrum distribution characteristics of the raw, TV-camera signal (Fig. 3). However, the presence of the color subcarrier (3.58 MHz for US standards) and its phase-modulated chrominance components, which are superimposed on the luminance signal, present a unique engineering problem in obtaining an FM signal that is within the limitations of present magnetic-recording technology.

The instantaneous amplitude of the color carrier is directly proportional to the excitation purity of the color of the televised object. Frequently, a high degree of excitation purity accompanies color objects, articles, or costumes in a typical television scene. The following general discussion of FM system requirements for a color TV video recorder is presented as a prelude to the detailed analysis of FM problems associated with the handling of the high-amplitude high-frequency signals associated with such scenes.

FM SYSTEM REQUIREMENTS

The frequency spectrum in which FM video recorders operate is shown in Table II. The selection of the frequency spectrum was based on the three basic requirements for FM magnetic-recording systems for television and the different degrees of compromise necessary to arrive at a workable system. The three basic requirements are as follows.

Wide Peak-Frequency Deviation

The signal-to-noise ratio of the magnetic recording system depends on a number of factors; some video noise is generated in every signal processing function throughout the playback system. Major noise sources are the finite graininess of the magnetic recording media, copper and eddy current losses of the magnetic playback head, FM preamplifier thermal agitation, and the FM system itself.

High Carrier Frequency

The spurious outputs present in the demodulated video signal are due to the various heterodyne products of the FM carrier, harmonics of the carrier, FM sidebands, and the modulating frequencies.

In a monochrome television video signal, although its basic bandwidth is 4.5 MHz, the frequency components with sufficient energy to produce spurious outputs are concentrated in the low-frequency (below 2 MHz) region of the spectrum. However, as shown in Fig. 3,

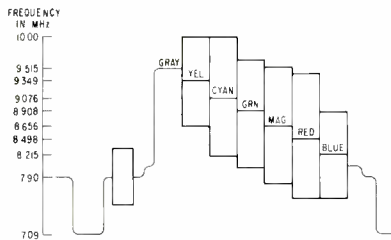

Fig. 4—Color bar signal and high band frequency standard.

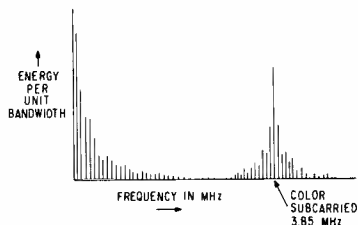

Fig. 5—Spectrum energy distribution of color-bar signal.

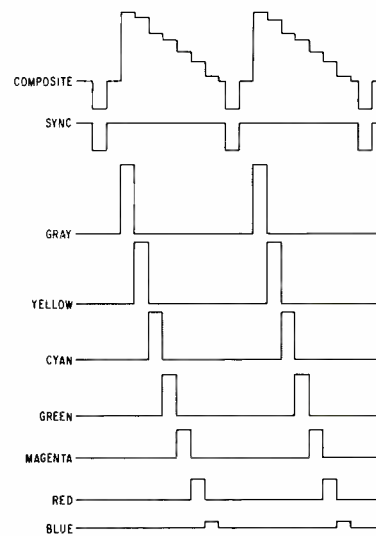

Fig. 6—Pulse composition of color-bar signal.

a color-television signal contains a substantial amount of energy in a region centered at the color subcarrier. Consequently, a great number of spurious outputs, with considerable energy, are created as sidebands associated with harmonics of the FM carrier and the color subcarrier.

To make the energy of the spurious outputs falling into the video spectrum insignificant in comparison to the primary video signal, the FM carrier frequency must be as high as possible.

Narrow FM-Frequency Spectrum

The output voltage induced upon the winding of a magnetic head under a given condition can be expressed as

$$e = \frac{\omega N E \eta / 2 R_F}{1 - (C_{IN} \omega^2 N^2 / B) + (\omega N^2 / B R_{IN})}$$

where ω is the angular frequency; N is the number of turns; E is the magnetomotive force of the recording media; η is the magnetic flux coupling capability; R_F is the total reluctance of the magnetic circuit; B is the magnetic head reluctance; C_{IN} is the input capacitance of the playback amplifier; and R_{IN} is the input resistance of the playback amplifier.

The primary factors governing the magnetic-head output voltage are the magnetic-flux coupling efficiency, the total reluctance of the magnetic circuits, and the effective gap width. All of these factors tend to reduce the output voltage as the frequency increases.

The three basic requirements are tempered by practical electrical and mechanical design limitations and the

present state-of-the-art in material technology, all of which make it desirable to narrow the bandwidth of a system and to have the system operate at the low end of the frequency spectrum. Thus, the FM magnetic-recording system chosen for television applications is a compromise. It was developed by weighing the levels of performance required (such as the signal-to-noise ratio and the system linearity) and then trying to fit these requirements into the finite bandwidth capability available with state-of-the-art recording/playback techniques.

WORST-CASE ANALYSIS OF HIGHBAND FM SYSTEM

The limitations of a system and potential sources of weakness can be found most readily by subjecting the system to a worst-case analysis. Therefore, the FM system for the color television magnetic recorder, or the highband system, should be analyzed using a worst-case video signal (most difficult to handle). Such a signal, a color-bar signal, is shown in Fig. 4. The signal is characterized by its wide variation of brightness levels and high degree of color saturation. Thus, it represents the maximum possible carrier frequency deviation and the most stringent requirements for the sideband energy distributions.

Luminance Spectrum-Energy Distribution

As shown in Fig. 5, the energy of the color-bar signal is separated into two bands, one representing luminance information in the zero to 1.5-MHz range and the other representing chrominance

information centered at the color-subcarrier frequency.

The luminance (or brightness) information is carried by a series of pulse trains superimposed in the time domain as shown in Fig. 6. The energy spectrum of each pulse train can be expressed as:

$$X(t) = \frac{V T}{T} \left(1 + 2 \sum_{n=1}^{\infty} \frac{\sin n \omega_c T / 2}{n \omega_c T / 2} \cos n \omega_c t \right)$$

where V is the peak amplitude of the pulse, T is the pulse width, T is the period, and ω_c is the angular frequency.

Since $1/T$ is the horizontal line frequency (15,750 Hz) and the width of each pulse is $1/8$ of the period, the energy of each pulse can be represented by approximately 8 discrete energy pulses as shown in Fig. 7.

Chrominance Spectrum-Energy Distribution

The chrominance information is carried by color-subcarrier on each step of the pulse train. The instantaneous amplitude and phase angle of the subcarrier represent, respectively, the degree of saturation and hue information of the color.

An expanded view of the portion of the color video spectrum centered about the color-subcarrier shows that the chrominance information for each step, like the luminance information, is carried by a number of discrete energy pulses spaced by the line-scan frequency (Fig. 8).

TABLE I—Modulation Characteristics of a Typical Video Signal

Modulating Frequency	Amplitude of Modulating Frequency	Carrier Freq. Deviation 100% Amplitude = 1 MHz	Modulation Index	Amplitude of 1st sideband
0.250	1.00	1.00	4	-0.07
0.500	0.50	0.50	1	+0.43
1.000	0.25	0.25	0.25	+0.12
2.000	0.12	0.12	0.06	+0.001
4.000	0.06	0.06	0.015	+0.0001

TABLE II—Carrier Frequency and Modulation Indexes for Color Bar Signal

Color	Carrier Frequency (MHz)	Modulation Index
Yellow	9.349	0.444
Cyan	9.076	0.630
Green	8.908	0.587
Magenta	8.656	0.587
Red	8.498	0.630
Blue	8.215	0.444
Blanking/Burst	7.900	0.286

Fig. 7—Energy distribution of a pulse train.

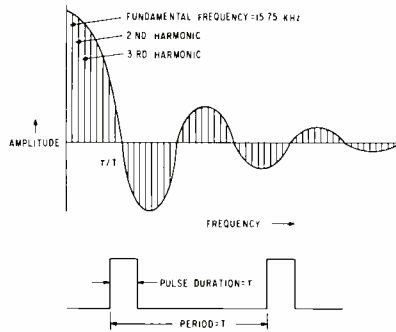

Fig. 8—Spectrum energy distribution of chrominance information in a video signal.

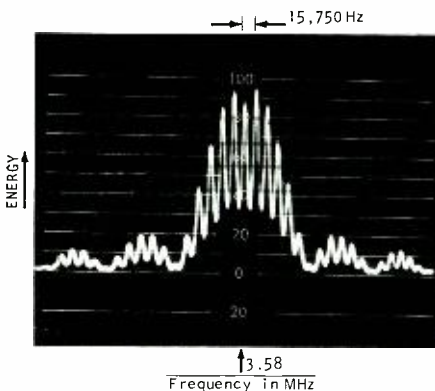
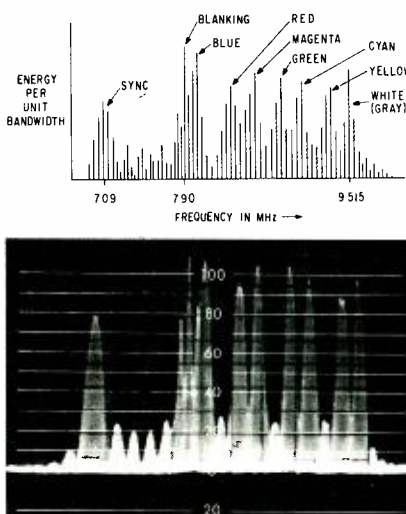

Fig. 9—Spectrum energy distribution of color-bar luminance information.



FM Spectrum Presentation — Luminance Signal

Each brightness step of the color-bar signal is associated with a definite FM carrier frequency as shown in Table II. However, because the pulse for each brightness level repeats itself at the line-scan frequency and the modulation index, *B*, has a considerable magnitude (generally > 10), the FM carrier for each step is displayed as a number of energy lines, each spaced by the line-scan frequency (15.75 kHz which is the *f_m*) as shown in Fig. 9. This energy band centers at a point corresponding to the deviated carrier frequency.

The relationships between the brightness level, *A*, frequency deviation, *f_a*, and the modulation index, *B*, are given in Table III.

FM Spectrum Presentation — Color Signal

Addition of the color subcarrier to the brightness levels can be treated as the modulation of each FM carrier (representing one brightness level) by another modulating frequency. This time the *f_m* = 3.58 MHz. The result is that, as shown in Fig. 10, each group of luminance carriers have groups of sidebands spaced by the new modulating frequency. The modulation index for this operation is generally less than unity.

GENERATION OF DISTORTION COMPONENTS (IDEAL SYSTEM)

Generation of spurious outputs in the demodulated video signal is caused almost entirely by the sidebands associated with the color subcarrier. It is of interest to note that, as shown in the following analysis, spurious outputs will be generated in a distortionless, ideal FM system. For the highband FM system, various frequency parameters were so chosen to make the energy of the unavoidable distortion components minimal.

The mechanism for generation of distortion components is shown, graphically, in Fig. 11. The example shown is for a single carrier frequency, *f_c*, of 8 MHz (approximately the blue bar) and a modulating frequency, *f_m*, of 3.58 MHz. In actual operation, as shown in the foregoing discussions, the carrier representing a certain brightness level is really a group of frequencies spaced by the line

scan frequency of 15.75 Hz. Therefore, the spurious outputs, even though shown as a single frequency in Fig. 11 consist of a number of energy spectrum lines centered around the shown frequency.

Basic ingredients which could produce spurious outputs are as follows:

Carrier frequency	$f_c = 8.00$
Modulating frequency	$f_m = 3.58$
1st sidebands	$f_c \pm f_m = 11.58$ (upper) 4.42 (lower)
2nd sidebands	$f_c \pm 2f_m = 15.16$ (upper) 0.84 (lower)
3rd sidebands	$f_c \pm 3f_m = 18.74$ (upper) 2.74 (lower, folded)
4th sidebands	$f_c \pm 4f_m = 22.32$ (upper) 6.32 (lower, folded)

The spurious outputs from this process are the demodulated outputs of the 3rd and 4th lower (folded) sidebands. Their frequencies are $8.00 - 2.74 = 5.26$ MHz and $8.00 - 6.32 = 1.68$ MHz.

The amplitude limiting employed in the FM demodulator produces 3rd and 5th harmonics of the carrier. Spurious signals would also be produced by the demodulation of the 3rd and 4th lower sidebands of the 3rd harmonic of the carrier. These frequencies are

$$(3f_c - 3f_m) - f_c = (24.00 - 10.74) - 8.00 = 5.26 \text{ MHz}$$

and

$$(3f_c - 4f_m) - f_c = (24.00 - 14.32) - 8.00 = 1.68 \text{ MHz}$$

These four outputs, located 5.26 and 1.68 MHz respectively away from both sides of the carrier, constitute two pairs of sidebands, and the finally demodulated spurious frequencies are 5.26 and 1.68 MHz respectively. Actual amplitudes of these distortion components are -36dB and -56dB with respect to the wanted output. The amplitude of sidebands and the modulation indices are tabulated in Tables IV and V. For the prevailing modulation index of 0.444 to 0.630 for the color-bar-signal, the amplitude of the distortion components resulting from the processes described above are in the area of -30 to -40dB for the 3rd sidebands and -54 to -60dB for the 4th sidebands. Fortunately, the majority of the distortion components from the 3rd sidebands fall outside of the final television-video spectrum, and we only have to cope with the 4th-sideband distortion components.

Fig. 10—Spectrum energy distribution of a composite color-bar signal.

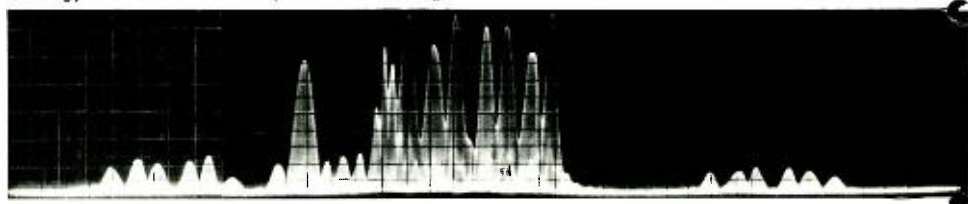
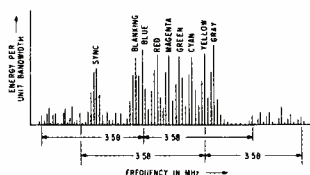

TABLE III — Level, Deviation, and Modulation Index of Different Colors

Color	Brightness Level (IRE Units)	Frequency Deviation	Modulation Index ($\Delta f_c/f_m$)
White	77	1.617	103
Yellow	69	1.449	92
Cyan	56	1.176	75
Green	48	1.008	64
Magenta	36	0.756	48
Red	28	0.588	37.3
Blue	15	0.315	20
Blanking	0	0	
Sync	-40	0.840	53

GENERATION OF DISTORTION COMPONENTS (PRACTICAL SYSTEM)

It has been shown that there are some spurious outputs that are unavoidable in the ideal FM system. The level of these spurious outputs (typically lower than -54dB) comprises the minimum level of spurious outputs. In a practical FM system, various forms of non-linearity exist during the process of modulation and demodulation. The commonly prevailing non-linearity elements which are damaging to the performance of an FM system are second harmonic distortion and amplitude modulation of the FM waveform.

Second Harmonic Distortion

A practical way to examine the extent of the performance degradation due to the second harmonic distortion is to analyze a system with a given amount of harmonic content. One-percent second harmonic distortion would cause a new carrier and its associated spectrum of sidebands to be generated at $2f_c \pm nf_m$ with a level 40 dB below the strength of the wanted spectrum. Basic ingredients which cause spurious outputs from the second harmonic distortion are as follows:

- Carrier frequency $f_c = 8.00$
- Modulating frequency $f_m = 3.58$
- 2nd Harmonic $2f_c = 16.00$
- 1st sideband $2f_c \pm f_m = 19.58$
(upper) 12.42 (lower)
- 2nd sideband $2f_c \pm 2f_m = 23.16$
(upper) 8.84 (lower)
- 3rd sideband $2f_c \pm 3f_m = 26.74$
(upper) 5.26 (lower)

The spurious outputs come from the lower sideband and their frequencies are

$$f_s = (2f_c - nf_m) - f_c = f_c - nf_m$$

when

- $n = 1, f_s = 4.42$
- $n = 2, f_s = 0.84$
- $n = 3, f_s = 2.74$

The process of spurious output generation by second harmonic distortion is shown graphically in Fig. 12. The level of the spurious output is the vector sum of all the terms at a single frequency. The frequency and relative level of the spurious output caused by second harmonic distortion is shown in Table VI.

Amplitude Modulation Distortion

Another form of distortion observed in a practical system is the amplitude modulation accompanying the FM waveform. An amplitude modulation of 1% (-40dB) present at the demodulator

TABLE IV — Sideband Amplitudes Referenced to Undeviated Carrier

Color	Carrier	Sideband		
		1st	2nd	3rd
Yellow	0.951	0.216	0.0245	0.0019
Cyan	0.903	0.299	0.0482	0.0051
Green	0.915	0.281	0.0420	0.0042
Magenta	0.915	0.281	0.0420	0.0042
Red	0.903	0.299	0.0482	0.0051
Blue	0.951	0.216	0.0245	0.0019
Burst	0.979	0.141	0.0103	0.0005

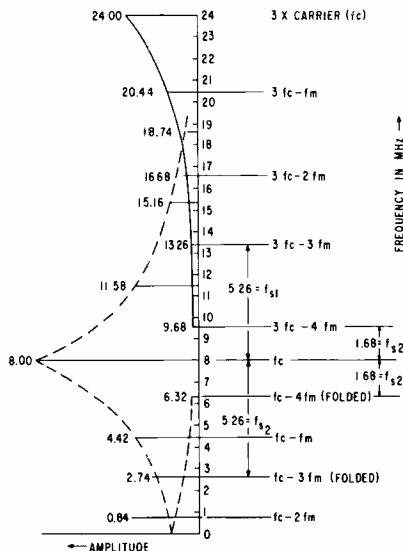

Fig. 11—Mechanism of generation of distortion components (ideal system).

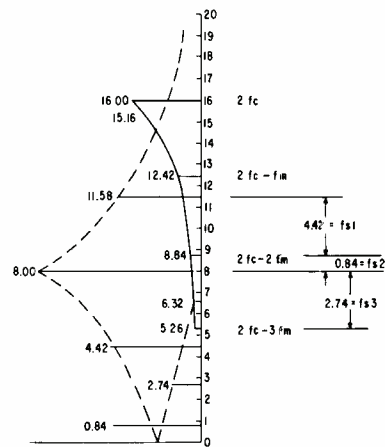

Fig. 12—Mechanism of generation of distortion components (practical system).

KOICHI SADASHIGE, a native of Japan, received the BSE from the University of Chiba, Japan, in 1947 and the MS in Jet Propulsion Engineering from California Institute of Technology in 1953. His entire RCA career since joining the Broadcast and Communications Division in 1953 has been devoted to the development of new products. He was responsible, under Dr. H. N. Kozanowski, for the showing of the new broadcast color television cameras at the National Association of Broadcasters' Conventions in 1961, 1963, and 1964. From 1964 to 1966, he was in charge of the development of new RCA Scientific Instruments, the EMU-4 electron microscope and the EMTV-I image intensifier television system. He is presently with electronic recording products advanced development engineering. He is a member of the Society of

Motion Picture and Television Engineers, Institute of Television Engineers (Japan), Japan Electron Microscope Society, and Aircraft Owners and Pilots Association.

JAMES VAN ANDA received the BSEE from North Carolina State University in 1966. Upon completion of the RCA rotational training program, he joined the Electronic Recording Products Engineering section of the Broadcast and Communications Products Division in November 1966. While attending North Carolina State, he ran his own TV service shop specializing in color TV installation and maintenance. During this period, he also constructed a TV camera and a magnetic video recorder of his own design. He is presently engaged in the development of subsystems for advanced video recording equipment.



TABLE V — Sideband Frequencies in MHz

Color	Lower Sideband			Upper Sideband		
	1st	2nd	3rd	1st	2nd	3rd
Yellow	5.789	2.189	— .391	12.929	16.509	20.089
Cyan	5.496	1.916	—1.664	12.656	16.236	19.816
Green	5.328	1.748	—1.832	12.488	16.068	19.648
Magenta	5.076	1.496	—2.694	12.236	15.816	19.396
Red	4.918	1.338	—2.242	12.078	15.658	19.238
Blue	4.635	1.055	—2.535	11.795	15.375	18.955
Burst	4.320	.740	—2.840	11.480	15.060	18.640

produces a spurious output of the following frequency:

$$f_s = f_c - f_m$$

$$f_s = 8.00 - 3.58 = 4.42 \text{ MHz}$$

In turn this spurious output heterodynes with the color subcarrier to produce another output at 0.84 MHz. The spurious outputs caused by AM are at the same frequencies as some of the second-harmonic spurious outputs and therefore add to the final distortion level observable at the video output.

SIGNAL-TO-NOISE ANALYSIS

Magnetic Recording Media

The noise from the recording media is believed to be generated because there is only a finite number of magnetic domains in the portion of the magnetic track occupied by the reproducing head at any given time. The phenomenon is somewhat analogous to the finite number of silver halide grains per unit area in film which limits the ultimate resolving power of the photographic system.

Magnetic Head Noise

The magnetic head represents a finite and varying impedance throughout its operating frequency range. The impedance is composed of reactive components and real components. The real components, representing copper (winding) and core loss, generate thermal-agitation noise as governed by Johnson's expression. This noise energy is centered at the resonant frequency of the head.

Amplifier Noise

The playback output from the magnetic head in present-day wideband magnetic recording systems is approximately 1 to 2 millivolts. This signal is applied to an FM amplifier that, itself, contributes a significant portion of the total noise power in the playback system. The spectrum of the amplifier noise is white, i.e., it contains essentially equal noise energy per unit bandwidth. The mechanism of the noise generation in a playback system is shown in Fig. 13.

Because response of the signal recovery process is not uniform over the entire frequency range of interest, various stages of equalization networks and amplifiers are included in the system. These compensation circuits modify the noise energy spectrum as well as the signal response of the system. The final

noise energy distribution at the input of the FM demodulator is shown in Fig. 14. To simplify the analysis, the noise is treated as an infinite number of independent sinusoidal voltages having the same frequency, voltage, and power as the noise. The change in carrier frequency caused by the independent sinusoidal voltages can be evaluated one at a time and then added to obtain the total change in carrier frequency caused by the noise. The change in carrier frequency caused by two voltages ω_n above and below the carrier frequency is given by:

$$\Delta f_c \text{ noise} = \frac{\omega_n E_n}{2\pi E_c} \cos \omega_n t$$

where ω_n is the noise frequency, E_n is the peak noise voltage, and E_c is the peak carrier voltage.

The output of a frequency demodulator is directly proportional to the change in carrier frequency. Therefore, the noise that is produced at the output of the demodulator is:

$$e_n = C \frac{\omega_n E_n}{2\pi E_c} \cos \omega_n t$$

The detected noise output of a frequency discriminator increases directly with noise frequency for a constant noise voltage, E_n . This type of spectrum is often called a triangular noise spectrum. The noise visibility decreases with frequency because of the integrating effects of the human eye and the television picture tube. Thus, for a given total noise energy, a triangular noise spectrum tends to give the viewer a quieter (higher signal-to-noise ratio) impression of the picture than a white-noise spectrum.

The signal-to-noise ratio of the tape FM system is the peak-to-peak signal voltage divided by the RMS noise voltage. The RMS noise voltage is

$$e_n = \frac{C}{\sqrt{2}} \frac{\omega_n E_n}{2\pi E_c} \cos \omega_n t$$

Fig. 13—Mechanism of playback noise generation.

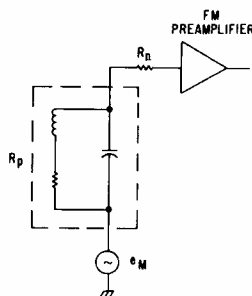

TABLE VI — Frequency and Relative Level of Spurious Outputs

Color	Frequency (MHz)	Level (dB)
Yellow	2.189	—41.8
Cyan	1.916	—42.3
Green	1.748	—42.5
Magenta	1.496	—42.96
Red	1.338	—43.27
Blue	1.055	—43.8

the signal output of the demodulator is $e_s = C\Delta f_c$ and the signal-to-noise ratio is then

$$S/N = \frac{2\pi \sqrt{2} B}{\omega_n \frac{E_n}{E_c}}$$

This equation shows that the signal-to-noise ratio decreases with noise frequency and increases with modulation index. Therefore, to ensure the best signal-to-noise ratio, it is essential that the modulation index be as large as possible. The typical FM noise spectrum, such as shown in Fig. 15, does not have a constant voltage level; therefore, its demodulation will not result in a triangular noise spectrum. Instead, because the voltage level decreases with frequency, the noise power output of the demodulator will increase only slightly with increasing frequency.

CONCLUDING REMARKS

In the communications industry it is felt that the frequency spectrum is one of the most precious commodities possessed by mankind. Our efforts in the development of newer and more advanced video recording systems should be directed not only to widening the bandwidth capability of the system, but also to compressing the information to be recorded into a narrower and more immutable bandwidth.

The authors regret that more vigorous treatment of the subject matter, especially the noise analysis, cannot be presented at this time because of space limitations.

ACKNOWLEDGEMENT

The authors express their sincere appreciation for the helpful suggestions and guidance received during the preparation of this paper from Mr. A. C. Luther, Jr., Manager, Electronic Recording Products Engineering.

Fig. 14—Spectrum distribution of noise at the demodulator input.

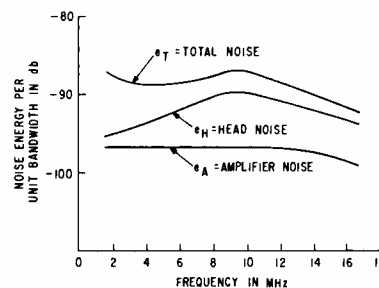

CORRECTION OF HUE AND SATURATION ERRORS IN TV TAPE RECORDING

Along with the increased use of tape recording for color TV programming comes the requirement for automatic correction of hue and saturation errors. This paper reviews some of the common causes of these errors and describes a chrominance amplitude and velocity error corrector (CAVEC) built by RCA to electronically compensate for variations in hue and saturation.

J. R. WEST, Ldr.

*Video Processing Product Design
Broadcast and Communications Products Division
Camden, N.J.*

A CONSIDERABLE percentage of the television programs broadcast today are fed to the transmitter from television tape recorders. These recorders are usually of the four-head or quadruplex types, which obtain the required bandwidth by mounting four heads ninety degrees apart on the periphery of a two-inch wheel and by rotating this wheel so that each of the four heads scan across a two-inch tape at a high speed (1500 in./s) as the tape moves relatively slowly (15 in./s) through the tape transport. Each of the four heads moves onto the tape in its turn, plays back a few tv scan lines (about 16), and moves off the bottom edge of the tape as the next head moves onto the top to play back the next 16 tv lines.

Although the quadruplex recorder made television tape recording practical for the first time, its operating principle, as described above, made it mandatory that great caution be used in both manufacture and operation, or certain characteristic picture distortions made it all too apparent to the viewer that the image was being dissected and reassembled in 16-line groups. In the early days of television tape recorders (about 1958) inept operation of the recorders often gave the home viewer the impression that he was viewing the picture through a venetian blind, with each "slat" of the "blind" representing a different 16-line group.

Fortunately, the economics allowed intensive development, so that in relatively short time, monochrome picture quality progressed to the point where

Final manuscript received December 1, 1967.

the home viewer could no longer discern the time and phase differences among the 16-line groups (called *head-bands*) which had made the groups, or head-bands, appear different from each other. The venetian-blind effect became a thing of the past, and monochrome picture quality took on the sparkling appearance of a live telecast.

The advent of color television brought another order of magnitude of sensitivity to the time and phase differences among head-bands. Since the hue of a color television picture is transmitted as the phase of a high frequency subcarrier, minute time and phase errors introduced by the recording process cause highly objectionable hue errors. Hence, a playback picture completely free of visible timing errors when viewed as a monochrome picture may, when viewed as a color picture, exhibit head bands which are, for example, red at the top and yellow at the bottom. This effect, which is repeated every 16 lines from the top to the bottom of the picture, is very obvious and annoying to the viewer.

J. RICHARD WEST was graduated from the Drexel Institute of Technology in 1957 with a BSEE. For two years, he was a communications staff officer at the US Army Aviation School. In November 1959, he joined the Electronic Recording Products Department of the Radio Corporation of America. In January 1967, he was promoted to group leader of the Video Processing Product Design group of the Electronic Recording Products Department. He has worked on the design and development of the Pixlock servo, Automatic Timing Corrector, Video Processing Amplifier, and the Chrominance Amplitude and Velocity Error Corrector.

These effects are caused by exceedingly minute mechanical errors in the assemblies which support the tape as the four heads scan across it. Since the information being played back is printed on the tape as a static pattern, it is converted back to frequency and phase only by the velocity of the head scanning across the pattern. If the support for the tape allows it to assume a shape different from the shape assumed during record, the effective velocity of the head relative to the printed pattern will be incorrect; hence, the head output will contain a phase error which will manifest itself as a hue error in the playback color picture.

A mechanical error of a few micro-inches will produce an objectionable color shift in a head band. Since it is not economically feasible to mass produce complex mechanical assemblies with tolerances in the micro-inch region, an electronic corrector (*velocity-error compensator*) was developed. This device is part of the subject of the paper that follows.

The other part of the paper deals with





Fig. 1—Color bar signal input.

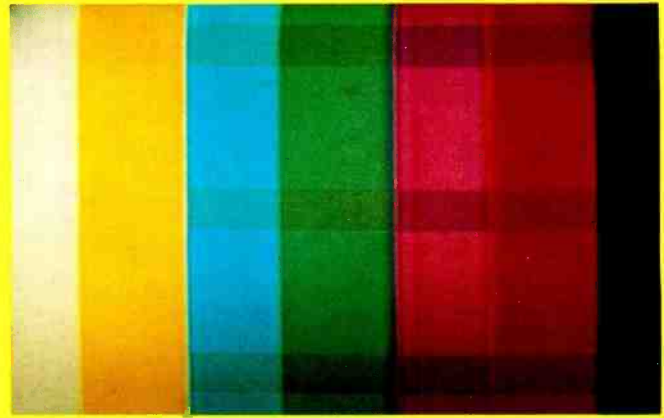

Fig. 2—Color bar signal playback of a recording made with incorrect record current in one channel resulting in a 2dB loss in chroma in that channel.

a companion device called the *chroma amplitude corrector*. This device recognizes another fault wherein a head band which should be, for example, red from top to bottom, may instead be too red at the top and too nearly pink at the bottom. Such a fault is called *saturation banding*, since the saturation of the colors varies within a given band. The causes of this problem, as well as the method used to correct it, are outlined in the paper.

CAUSES OF HUE AND SATURATION ERRORS

Velocity errors in a quadruplex TV tape recorder are caused by very small mechanical or geometric differences between the way the recording head scans the tape and the way the playback head scans the tape. The mechanical differences causing these velocity errors are so small that it is neither economically feasible nor technically possible to consider total elimination of the velocity errors by tightening tolerances. The velocity errors result in phase error shift of the color subcarrier within a head band. This causes change in hue from the left side of a color picture to the right side, or from the top of a head band to the bottom.

Saturation or chrominance amplitude errors can result from similar mechanical differences. These differences can cause changes in head-to-tape contact as the head scans across the tape, resulting in a change in frequency response in the demodulated color signal. These errors in frequency response are seen in the picture as saturation errors within a head band. Saturation error may also be a function of the tape alone if the tape is not uniform in thickness or homogeneous in its coating.

However, the purpose of this paper is

not to describe all the causes of hue and saturation errors in TV tape recording. Rather, this paper will describe a device which senses and corrects these errors regardless of cause. The device, called CAVEC (Chrominance Amplitude and Velocity Error Corrector) corrects both hue and saturation on a line-by-line basis in the playback machine. It is important to emphasize that the correction is line-by-line because line-by-line chrominance amplitude correction was not possible before CAVEC.

PRIOR METHODS OF ERROR CORRECTION

Some of the errors present in TV tape recordings can be compensated for by manual adjustments in the playback mode. This is true for both chrominance amplitude errors and velocity errors. But it is difficult to remove both effects simultaneously, and in removing one effect, the operator may cause the other. For instance, if a recording made on one machine is interchanged—that is, played back on another machine—and objectionable saturation banding is seen, it may be eliminated by adjusting the height of the mechanical guide which supports the tape as the heads scan across it. In addition, electrical adjustments on individual heads may be made by manually controlling the frequency response of the four individual channels. By these methods, the saturation banding may be compensated perfectly, but in doing so velocity errors can be introduced. Velocity errors are seen as a continuous change in hue across a TV line or down a head band. The result is that the picture probably looks worse now than it did with the original saturation banding error. Thus no matter what you do or how many adjustments you make, the end result in playing back a color

interchange tape that had errors in the recording is some form of color banding. With most of the TV broadcasting being done in color, the broadcaster has been hard pressed to maintain a high quality picture because of the volume of color programming and perhaps because of the quality of the recordings coming from various sources.

Some examples of what the operator is faced with are shown in the color pictures, (Figs. 1, 2, and 3). Fig. 1 is the color-bar signal at the input to the tape recorder. It is, of course, the function of the TV tape recorder to reproduce this signal exactly as it appears at the input. Fig. 2 illustrates the playback of a recording made with the record current reduced in one channel (16 TV lines), which produces a playback 2 dB low in saturation for that channel. Fig. 3 demonstrates the effect on the picture if the height of the guide supporting the tape is not correctly adjusted. The guide height was misadjusted 0.0006 inch to introduce the error in Fig. 3. It may be possible to make manual adjustments to correct either of the errors shown; difficulties arise however, when the broadcaster attempts to assemble a program with tapes recorded from sources all over the country.

CAVEC

The CAVEC unit provides continuous and automatic control and correction for the variables that result in color hue and saturation error.

Fig. 5—Chrominance amplitude and phase corrector.

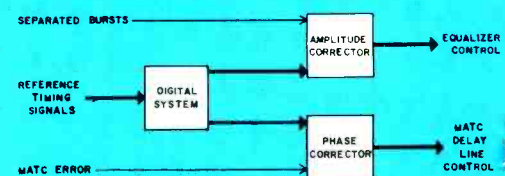

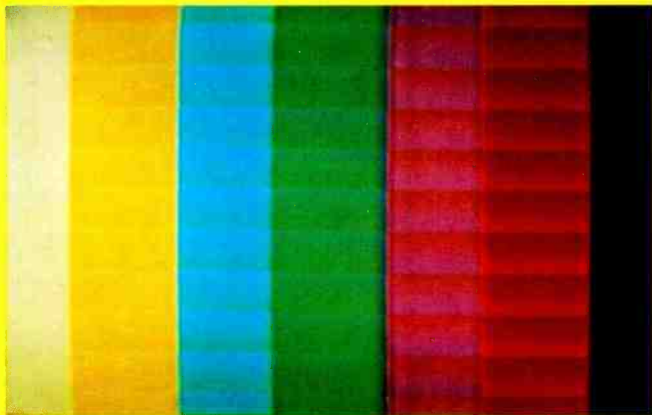

Fig. 3—Color bar signal playback with guide height misadjusted by 0.0007 inch.

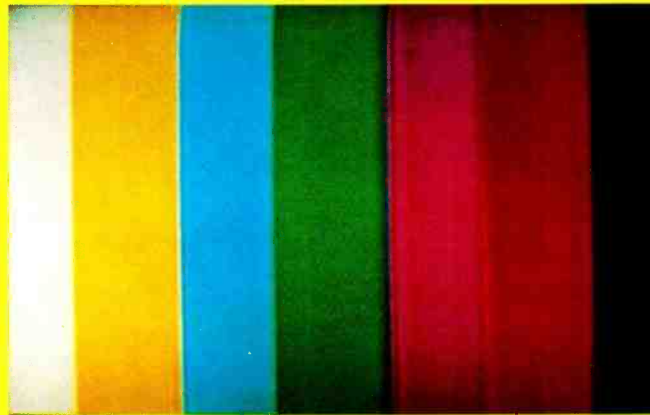

Fig. 4—Color bar signal playback on a TR-70 highband TV tape recorder with CAVEC module operating to automatically correct errors shown in Figs. 2 and 3.

The functioning of the CAVEC module (Fig. 5) is most easily described by dividing the unit into three basic parts:

- 1) A digitally-addressed analog memory system, from which the line-by-line correction is obtained,
- 2) A velocity error detector and phase corrector, and
- 3) A chrominance amplitude detector and electronically variable equalizer.

Line-by-line correction is made possible by the basic assumption that errors found in one revolution of the headwheel will also be present in the next revolution of the headwheel. By storing the errors found on one revolution, it is possible to correct subsequent revolutions. During the head revolution, each of the four heads scan 16 tv lines. To store information for one complete revolution, 64 memories are required. Separate memories are needed for hue and saturation correction; thus the memories are doubled, for a total of 128. The memories are capacitors which are charged in about 0.1 seconds or 24 revolutions of the headwheel. It should be recognized here that instantaneous changes in either hue or saturation errors will not be corrected to some absolute value but will be corrected to the average value of the previous 24 revolutions of the headwheel.

Since the correction is line-by-line, it is necessary to identify each of the 64 tv lines of one headwheel revolution in order to direct each line's error to the proper memory bin. Four signal inputs are required for the digital address sys-

tem to the memory capacitors (Fig. 6). The head-switching waveforms (called 4x2 and 2x1 in the Figure) from the playback system of the tape recorder are used to identify head number one of each revolution of the wheel. The horizontal sync pulses from the tape are utilized to identify the beginning of each tv line within a head band. Line one for a given band is identified as the first horizontal sync pulse occurring after the head is switched on for that head band.

There are two deviations from this straightforward and logical address system.

- 1) Some head bands will contain 17 lines instead of 16 lines. Only information for the first 16 lines is stored. In reading out the stored errors, information from line 16 of any head band is repeated when a 17th line occurs in that head band.
- 2) The chrominance amplitude portion of CAVEC derives its information from sampling the amplitude of color synchronizing burst which occurs just after the horizontal pulse on each line. However, during the vertical interval (9 lines at the bottom of the picture) there is no burst. Since the same head always plays back the vertical interval in the tv tape recorder, the average of the sampling of burst amplitude would not be correct for that head. Therefore, the memory write function is inhibited during the 9-line vertical interval. This simply means that for some lines in the head which plays the vertical interval, the average error is derived from 25% fewer samples.

The errors, once measured, must be directed to the proper one of the 64 memory bins. This direction, or addressing, is accomplished by utilizing the waveforms which switch on each head in its turn as it moves onto the tape to scan its 16-line sequence. The switching action operates in such a way as to first reduce the four head channels to only two (4x2 switching) and then to reduce these two to only one (2x1 switching).

Digital System

Fig. 7 shows some typical waveforms in the digital system. The head switching waveform (2x1) in the domestic tv system occurs at a 960 Hz rate. The 2x1 and 4x2 signals are decoded to form four unique Y waveforms, one for each of the four magnetic heads in the quadruplex tv tape recorder. The 2x1 and 4x2 waveforms originate in the FM switcher of the tape recorder. The line switching utilizes the tv system horizontal sync recovered from the tape. This signal occurs at a 15.75-KHz rate. The X, or line decoding, results in sixteen unique X waveforms for each Y waveform. The X and Y signals combine to form the address system to two different sets of sixty-four memory capacitors.

Fig. 8 shows the Y decoder in detailed digital logic format. The symbols for the digital functions follow standards that are used throughout the industry. These symbols describe each element of every

Fig. 6—Digital system.

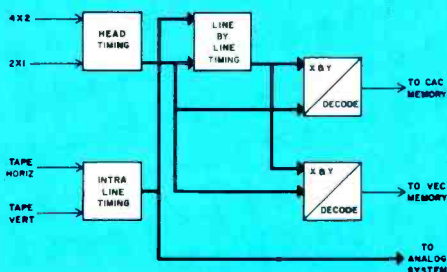

Fig. 7—"X" and "Y" waveforms.

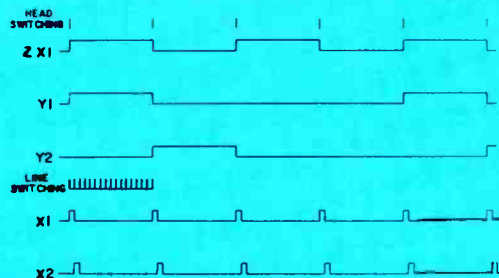
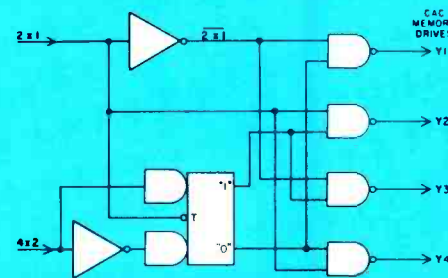

Fig. 8—Digital logic Y decoder.



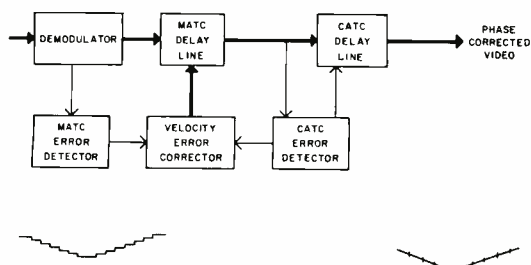

Fig. 9—Velocity error corrector playback system.

integrated circuit in the digital system. This particular segment depicts the circuitry necessary to identify the four heads utilizing the 2x1 and 4x2 input signals. Except for the inputs, the logic sequence shown for the Y decoder is similar to that for the 16 line drivers associated with each of the four heads.

Velocity Error Corrector

The velocity error corrector fits into the tape recorder playback system as shown in Fig. 9. The velocity error is detected by measuring the height of the steps in the monochrome automatic timing corrector (MATC) error signal. These steps represent a sudden correction of a velocity error accumulated during the tv line. Linear ramps are made and added to the MATC error signal, resulting in a continuously changing waveform instead of the stepped waveform shown on the left. The result is that, although the automatic timing corrector samples only once at the beginning of each tv line, the electronically variable delay line controlled by the MATC changes its delay continuously across the line. The system

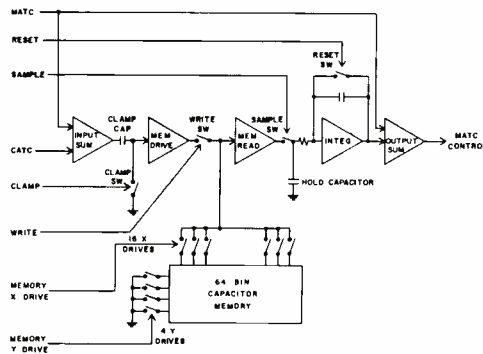

Fig. 10—Velocity error corrector analog system.

operates on the assumption that the velocity errors are linear across the line. This may not be strictly true, but it is a much closer approximation to the true error than the stepped MATC waveform. This correction is open-looped; i.e., there is no feedback information.

The velocity error correction analog system is shown in Fig. 10 with all inputs and outputs. Of the many input signals, only the monochrome automatic timing corrector and color automatic timing corrector error signals come from outside the CAVEC. The others—clamp, write, sample and reset as well as the X and Y drives to the 64 bin capacitor memory—originate in the digital system of CAVEC.

The function of this system is to measure the amplitude of the steps in the MATC error signal, store and average the information, and then sample the average and build a linear ramp whose length equals one tv line, and whose height equals the magnitude of the velocity error which has been regularly occurring in that line. This is then added to the MATC error signal and results in a

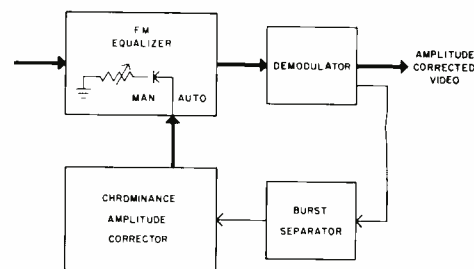

Fig. 11—Chrominance amplitude corrector playback system.

continuous waveform rather than a stepped waveform.

At the input, the MATC and CATC error signals are added to cancel some of the dc jitter which is inherent in the MATC error signal. The signal from the input summing circuit charges a capacitor which is clamped to ground. The clamp is timed to operate near the end of a line interval. When the ATC occurs at the beginning of the next line, the clamp is lifted, and the capacitor charges to the dc difference between the two line intervals. This difference signal is amplified by the memory drive and coupled to one of the 64 memory capacitors by the write switch.

During the read interval, the charge from one of the capacitors in the memory is coupled to the memory read amplifier. In the horizontal sync interval, the sample switch operates and charges the hold capacitor. This hold capacitor maintains the charge for the remainder of that tv line. The integrator which has subsequently been reset builds a linear ramp equal in amplitude to the dc level on the hold capacitor. This ramp, when

Fig. 12—Chrominance amplitude corrector analog system.

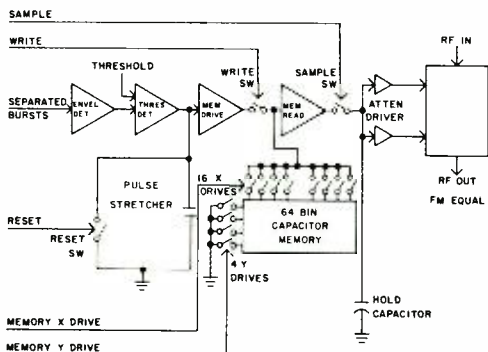

Fig. 13—Analog board.

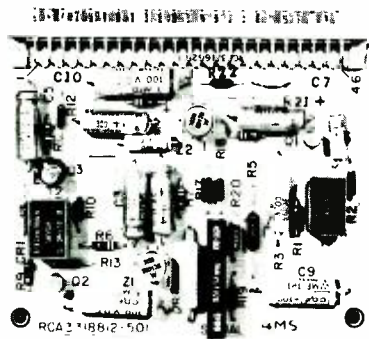
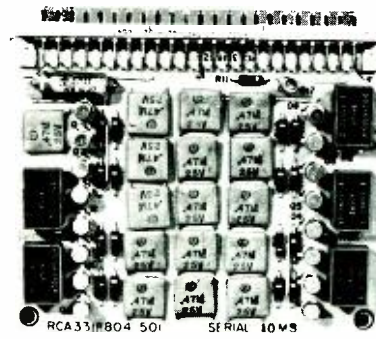

Fig. 14—Memory board.



added to the MATC error signal, provides continuous control of the ATC delay line.

Chrominance Amplitude Correction

Fig. 11 shows the chrominance amplitude portion of CAVEC and how it fits functionally into the playback system of the tape recorder. Color burst is separated from the demodulated video signal. The burst amplitude is measured and compared to a reference. The resulting error signal is used to control the FM equalization (frequency response) of the playback system. Normally, the four playback amplifier equalizers and the master equalizer are adjusted to set the level of demodulated burst and chroma amplitude. They do not necessarily set the frequency response of the system so that it is flat.

The chrominance amplitude corrector controls the equalization provided by the master equalizer. It can change the amount of equalization provided by the master equalizer on a line-by-line basis, thereby correcting saturation on a line-by-line basis.

The accuracy of this system depends on the amplitude of instantaneous changes in burst level, relative to the average level stored in the memory for any particular line. Also, since only the burst is sampled, it must represent the chroma level desired for *all* color information in the picture. This is true, of course, as long as there is no differential gain in the system. Differential gain—a system fault which causes saturation of a picture area to depend upon the brightness of that area—can disturb the picture because reference burst, which is always at black level, will not be a proper reference for high-brightness areas. Differential gain on a band-by-band basis will cause an apparent band-by-band saturation error, but in high-brightness areas only.

The chrominance amplitude correction analog system (Fig. 12) looks much like

the velocity error correction system. Again, the write, sample, reset, and X and Y drives to the memory all originate in the digital portion of CAVEC. The operation of the memory in the chrominance amplitude corrector is identical to the operation of the VEC memory.

The separated burst from each TV line passes into the envelope detector where it is amplified, rectified, and low-pass filtered. The detected burst is then stretched to minimize the effects of noise and position relative to sync. The resultant signal is amplified in the memory drive amplifier. Once during each line, the memory drive amplifier is connected to one of the memory cells in the 64-bin memory by the write switch. The write switch is inhibited during those lines in the vertical interval that do not contain a burst. During the read time, one capacitor from the memory is connected to the memory read amplifier. The signal is sampled and held for a complete TV line by the hold capacitor. The dc on the hold capacitor drives an electronically-variable FM equalizer in the tape recorder playback system. The variable equalizer changes the playback equalization and therefore the burst level. Since the burst is separated from the demodulated signal at a later point in the system, the chrominance amplitude corrector operates as a closed loop. On a real-time basis, the read function takes place first and the resultant burst amplitude is detected and written to update the memory. Loop stability of the system is governed by the averaging capability of the memory.

CONSTRUCTION

The active elements in the analog circuitry of CAVEC contain both operational amplifier integrated circuits and transistors. All the analog functions are performed with just 13 integrated circuits and 33 transistors.

Each memory board mounts 16 memory bins (capacitors) and 17 dual-emitter transistors. Four memory boards

are used for the velocity-error storage, and four similar boards are used for the chrominance amplitude error storage.

The board shown in Fig. 15 is one of several types of digital logic boards. The eight dual-in-line integrated circuits shown provide eight four-input logic gates and eight two-input logic gates.

The CAVEC module nest contains a total of 26 boards of 14 different types. In all, there are a total of 253 active elements, 84 integrated circuits and 169 transistors. Since the device contains 128 unique memory cells, there are just under two active elements per memory cell. The interconnection wiring on the back-plane of the nest is programmed and done automatically utilizing wire-wrap techniques.

This unit is in full production. Field experience has shown it to be extremely reliable. There are no operating controls on the module: simply ON or OFF. All correction is fully automatic. The module plugs into any RCA highband tape recorder; i.e., any TR-3, TR-4, or TR-22 which has been converted for highband use, or the TR-70.

CONCLUDING REMARKS

The more that color tapes are interchanged, copied, and spliced, the more it becomes necessary to provide means for automatically correcting hue and saturation errors. The CAVEC has provided the users of television tape recorders this required capability, and hence has given the television viewer another large increment of improvement in his color television picture.

ACKNOWLEDGEMENT

The work of the Missile and Surface Radar Division of DEP in the design, development, and production of the CAVEC unit is gratefully acknowledged. Specifically, T. Bolger of M&SR worked on the basic design, assisted in preparation of this manuscript, and has a patent application pending on this device.

Fig. 15—Digital board.

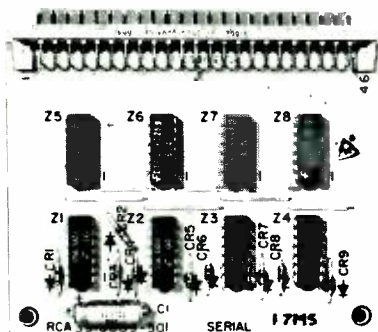
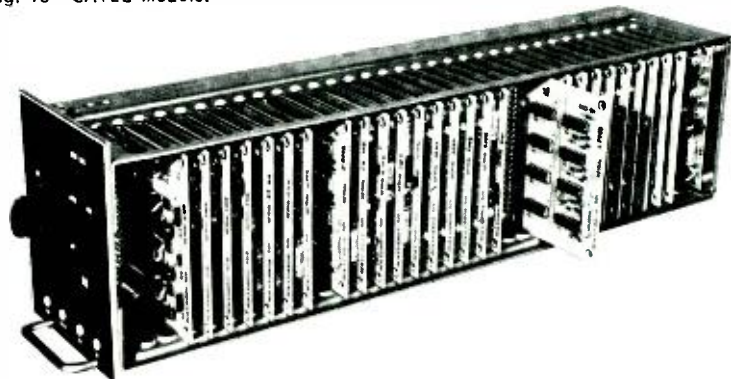

Fig. 16—CAVEC module.



ADVANCED TV PROGRAM SWITCHING EQUIPMENT

This paper considers modern TV program switching requirements and the design of modern TV switchers to select, route, and monitor program sources. Such equipment revolves around the TS-51 switcher used as a basic building block. Design philosophy, packaging, and performance are areas described in detail.

J. M. WALTER, F. D. RANDO* and C. R. MONRO, Ldr.

Terminal and Projector Equipment,

Broadcast and Communications Products Division, Camden, N.J.

ESSENTIALLY, video switching equipments are signal-routing devices, but this over-simplification serves only to identify TV switchers as something quite different from program sources such as cameras or tape machines. The TV switcher, wherever it is used, permits the operator (man or machine) to select any input among the various program and test material sources commonly found in a TV station. This one function of rapid selection makes the switcher invaluable.

TV SWITCHING REQUIREMENTS

The importance of TV switchers becomes apparent when a study is made of the various signal sources being handled. Sources of TV programs generally involve much more than just the video signal. At the very least, consider the accompanying program sound, separate cueing signals, and various pieces of digital information either emanating from the source or being fed back to it. These latter functions are supervisory control network functions distributed in the station, identified as camera tally, sync interlock, and panel button lamp circuits. Necessarily, the switcher becomes a multi-level device for sorting and selecting all these various levels.

From a control standpoint, the switcher appears to the operator as a set of pushbuttons that either interlock (latch) mechanically by themselves to insure that only one input appears at the output at any given time, or the buttons may be momentary contact devices with the latch being accomplished inside the switcher.

The latter approach immediately expands into remote-control switchers and

leads to automatic switching wherein the switcher itself is sequenced by another machine, such as a clock, or even a computer. Such control is more than just a peripheral convenience; today's modern TV stations frequently require the switching of program material in such a rapid sequence of events and at such precise times as to preclude human operation.

Another less obvious but important reason for remote control is the removal of electronics from the studio control rooms. In particular, TV switcher operating panels are frequently mounted in desk-type consoles where even routine maintenance would be troublesome. Pushbuttons are generally reliable to the point of requiring almost no maintenance; by using only these devices at the control panel with the electronics located in a more accessible area, overall maintenance is simplified.

The choice of mechanical or electrical control depends generally on location. Within a main control room, where signals are available, the simple mechanical switcher is entirely adequate for monitoring, local control-room distribution, and even as a back-up for the transmitter feedline. On the other hand, the remote-control feature of the momentary closure button allows push-button panels to be located all over the station in clients' viewing rooms, studio control rooms, and tape recorder locations, with the actual switching of program material being handled at some central location.

The various levels of supervisory control functions to be sorted at the switcher are as much a part of the system as the video signal itself. Often disdainfully referred to as the *doorbell circuits*, these various digital signals are the skeleton that holds the station op-

eration together. For example, the *tally* is a panel or group of lights on the camera (or tape machine); individual tally lights identify and convey information to both the talent and the operator. The most easily recognized signal is the camera ON AIR tally; it identifies which of the many cameras (and tape machines) involved in a production is feeding the transmitter.

Cameras in an ON AIR status are under the constant supervision of the program director; the picture from that camera must not be disturbed or altered in any way except at the command of the director. Likewise, tape machines identified as ON AIR must not be disturbed for any reason other than an emergency. A second level of camera lights includes the IN USE or BUSY status level. This function originates in the switcher and signals the camera on a separate set of tally lights that the camera is busy but not ON AIR; such cameras are considered not available for service elsewhere until the BUSY status is lifted.

Still another level of tally confirms that the switcher has responded as directed. For example, when the TV switcher has completed the required switching, it lights the associated "command" button at the program director's console. This feedback may be used to alert a computer to advance its memory to the next event.

Two other supervisory network levels identify the composition of the input video signal. These are the *composite sense* (the signal has sync on it) and the *remote sense* (the signal is not synchronous to the station). These signals are vital to the operation of mixing and special effects equipment, and in the control of sync additions to the switcher output. It is indeed fortunate that the

Final manuscript received November 11, 1967.

* Since this paper was written, Mr. Rando has left RCA.

supervisory control signals are digital (on-off) in nature; thus, these signals can be handled by simple logic circuitry whereas the analog video signals require broadband, active, linear networks with the added complication of being on-off devices.

Because of the unique problems involved in switching program sound, audio switching functions are kept as a separate entity that receives optional control from the video switcher. The primary reason for separation of the audio operation is that picture and sound sources do not always emanate from the same location. As an example, pictures derived from slides have no sound of their own; sound must be supplied from disc recording, cartridge tapes, or live audio.

TYPES OF SWITCHERS BY FUNCTION

Having discussed the switcher as a programming tool and general supervisory system, attention is directed to particular areas in a TV station requiring switchers.

The simplest switcher function concerns the single output-bus distribution switcher. Whether mechanical, electro-mechanical, or electronic in operation the switcher allows one to select and monitor tape machine input, the clients' monitor, or any other available program material. In the master-control room, there may be a pushbutton panel with separate rows for each output bus. The operator may have several different monitors, such as ON AIR, preview, re-

mote source, and tape machine output monitors. Of course, where audio and supervisory control information must also be processed, the switcher may be expected to do the whole job.

The program assembly switcher is generally more complex in its format. This is an ON AIR editing device that provides smooth transition from one camera to another while the program is in progress. In this application, the switcher and the mix-effects system are combined on one control panel. As the TV industry grows, production requirements become increasingly sophisticated and the program switcher becomes a system of its own, often requiring special fabrication from existing hardware to meet the individual requirements of the customer.

CURRENT VIDEO SWITCHING DEVICES

The first mechanical video switchers featured simplicity of design, low cost, and positive operation and are still popular today for the same reasons.

The mechanical switcher has its own latching and memory (hold); generally, video performance is excellent. Assuming the mechanical device to be the whole switcher (i.e., no input or output amplifiers), there will be no linearity distortion, and the discontinuity introduced by contacts in the two cables is so slight that effects on frequency response are difficult to measure in the usual video band.

However, simplicity of design and operation limits the usefulness of the

mechanical switcher. Remote control is not practical and adding inputs to the switcher requires extension of the latch mechanism which has never been a workable approach. Because of these and other limitations, the industry long ago moved to the momentary contact button and remote-controlled switching for larger systems. Nevertheless, the mechanical switcher is still manufactured for use in simple distribution and program assembly operations (Fig. 1).

The electro-mechanical switcher using momentary buttons replaces the mechanical latch with an electrical relay making remote control possible (Fig. 2). The signal switching device is a relay (or possibly a stepper); to achieve the desired performance, a special relay design is necessary. A degree of bounce, insignificant in normal relay applications, may add an objectionable disturbance to a picture signal; so considerable design effort has been spent to produce relays having little or no bounce.

The availability of low-cost diodes and transistors made practical the large-scale use of all-electronic video switching. Electronic switching has many advantages over both the mechanical and the relay device—the most dramatic performance advantage being speed. The switch can be timed to occur in a particular line during the vertical blanking interval (where it cannot be seen) with the time of actual switching reduced to microseconds. Because of the small solid-state electronic components, me-

Fig. 1—TS-2 mechanical switcher.

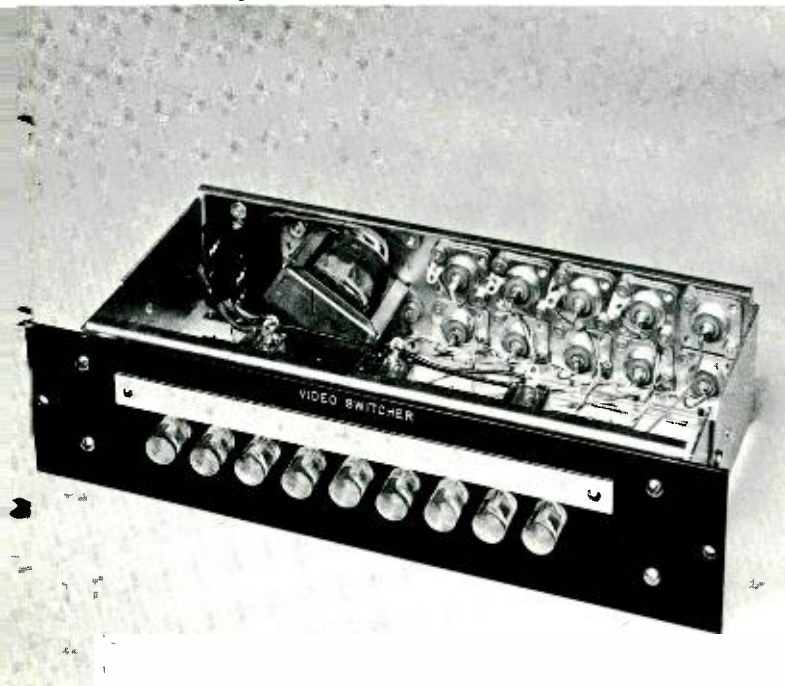
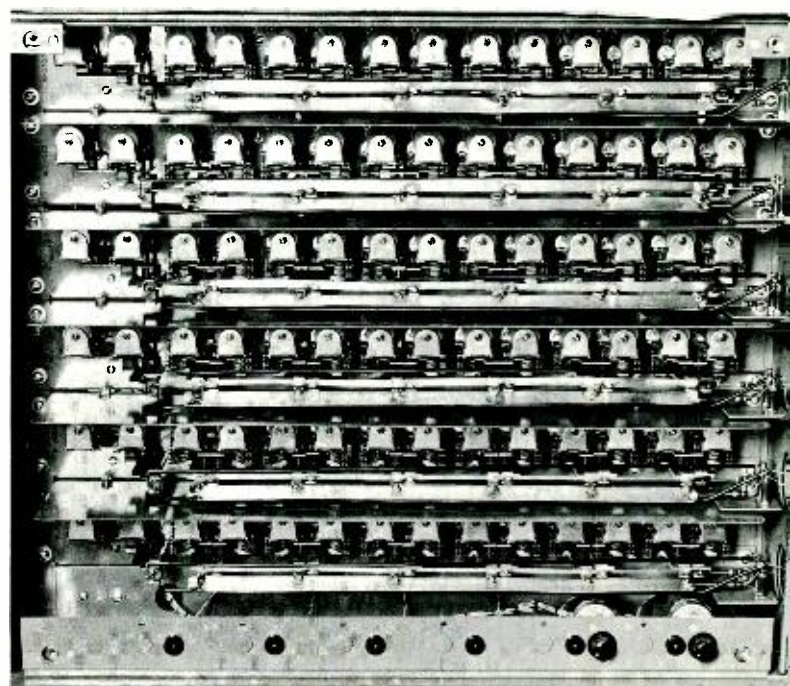

Fig. 2—TS-21 electro-mechanical switcher.



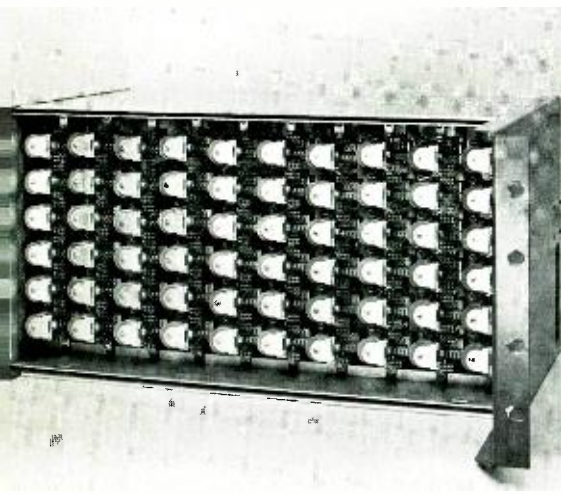

Fig. 3—TS-40 components.

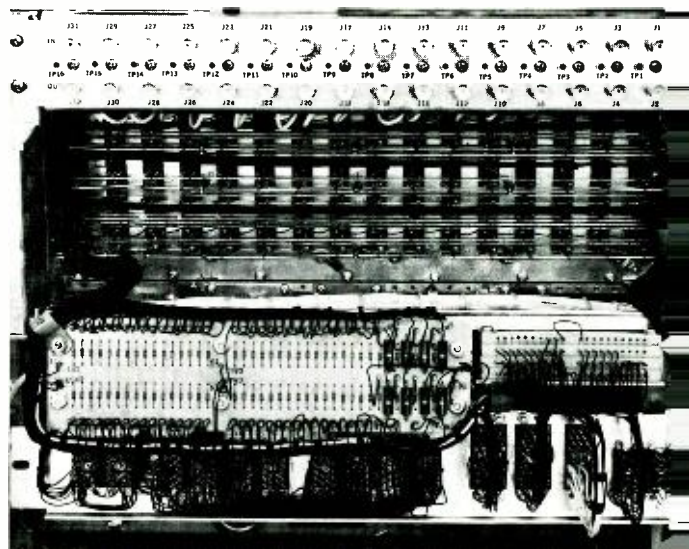
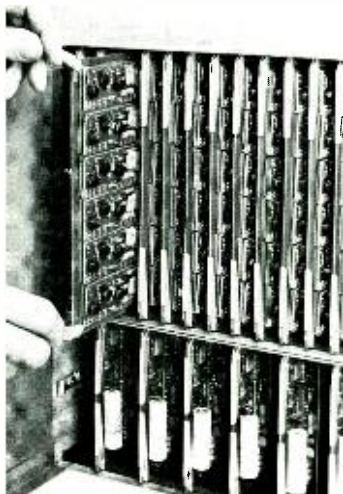

Fig. 4—TS-51 switcher frame.

chanical size of a given switching grid can be reduced sufficiently to improve system bandwidth (Fig. 3). The greatest customer benefit derived from the electronic switcher is freedom from maintenance.

NEW DESIGN PHILOSOPHY

With considerable background in video switching, TV Terminal Engineering un-

dertook the design of a new switcher to replace some of the older equipment and round out the product line to compete in other switcher areas. Typical of any new design, the scope of the product was studied carefully and a set of design objectives drawn up; the new family of switchers was to provide the following five major features:

- 1) An integrated video and control circuit building block;

- 2) Solid-state control signal outputs;
- 3) A single wire panel control system;
- 4) Outstanding video performance; and
- 5) Suppression of the effects of step-function shifts that result from switching signals of differing duty-cycle (APL corrector).

THE BASIC BUILDING BLOCK

The basic building block for the new family of switchers is the TS-51 (Fig. 4). The TS-51 contains the 16-input by 4-output video and control circuit grid. This grid is packaged in a 19x7-inch modified standard studio equipment module frame. The frame holds an output module, a row control module, and up to 16 input modules. Variation of the number of inputs may be made in single units within the groups of sixteen. Output expansion is done in groups of four by bridging the video input signal through 2 or more frames. Of the three different module cards, the input module (Fig. 5) is the most complex in terms of packaging. The input card is really a carrier and interconnecting device for three smaller sub-boards. One sub-board is the input amplifier and a set of four video crosspoints, located at the tongue end of the input card; video enters and leaves the module on the shortest interconnecting runs. Another sub-board is the associated supervisory control network (which has been re-named the DC control board) and the final sub-board contains the IC memory and electronic latch. This approach to packaging was chosen as an alternative to a multi-layer board, with all the components mounted on it. Recognizing that two planes were not enough to provide all the interconnection that would be needed, the carrier board-sub-board approach provided the required extra layers and allowed the manufacture and test of the various

J. M. WALTER received the BSEE in 1959, and joined the Broadcast and Communications Products Division of RCA as a TV systems engineer. In June of 1960, he was ordered to active duty with the U.S. Army Signal Corps as an electronics officer and subsequently was assigned to the TV Division of the Army Pictorial Center in Long Island, N.Y. After completion of two years army service, Mr. Walter returned to RCA. In 1963, he was transferred to the TV terminal activity where he has worked on sync generators and switching equipment. Mr. Walter is a member of IEEE.

C. R. MONRO received the BE degree from the University of Toledo in 1942. The same year he joined RCA at Indianapolis. During the war years he was engaged in engineering liaison related to the manufacture of Navy underwater sound listen-

ing and echo ranging equipment. After a year's Army service, he returned to RCA in the Sound Products Division in Camden. He was responsible for product design of audio amplifier and wire recording equipment for commercial sound applications. In 1948, he joined the Broadcast Television Studio group, engaged in projects related to video signal distribution and switching systems. Also, he was associated with the design of flying-spot cameras and monitors for both monochrome and color. He is currently a Leader in the Terminal and Projector Equipment group, responsible for a number of units related to studio and distribution video switching systems; sync generator and pulse distribution systems; and special video amplifiers for mixing special effects and processing functions. Mr. Monro is a registered professional engineer in the State of New Jersey and is a member of IEEE and SMPTE.



J. M. Walter



C. R. Monro

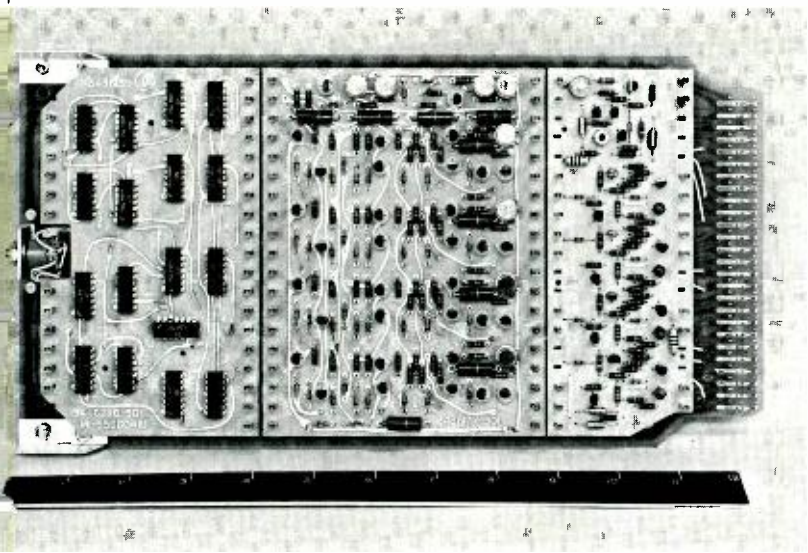

Fig. 5—TS-51 input module.

pieces before they became part of the final assembly, which would be an aid to production. Finally, the sub-board approach makes field servicing easier in that the customer may want to stock some of the sub-boards as spares and these pieces would be less expensive as separate entities than if all the components were on one board, necessitating changing the whole module to repair one circuit section.

On a per-input basis, the TS-51 requires 1) the video signal and 2) signal sense information (local, remote, composite, non-composite). The signal sense information is supplied into the grid through a selector switch. The switch is set in one of four positions: non-composite, composite, remote, or external. The external position allows this selection to be made at the panel or from another switcher. To each input, the TS-51 supplies two levels of tally information (IN USE TALLY and ON AIR TALLY).

On a per-output basis, the switcher supplies the capability to drive two 75-ohm coaxial lines; two discrete levels of sync follow: remote/local, and composite/non-composite. A slave hold output is also supplied. The only information supplied to the TS-51 on a per-output basis is an ON AIR TALLY signal.

CONTROL SIGNAL OUTPUTS

All the tally and sync-interlock output signals from the switcher are transistor closures to ground. This was done to standardize control signal outputs from the switcher, to afford maximum protection for the transistorized output drivers, and to provide a simple, meaningful nomenclature. For example, the ON AIR signal is a transistor closure to ground capable of carrying 450 mA from a posi-

tive 24-volt supply whenever that input source has achieved ON-AIR status. Likewise, the non-composite sense output signal is a transistor closure to ground capable of carrying 50 mA from a positive 24-volt supply whenever the video output signal is a non-composite signal. Other signals covered by this same rule include the IN-USE TALLY, COMPOSITE SENSE, REMOTE SENSE, and LOCAL SENSE signals.

SINGLE-WIRE CONTROL

The new switcher requires only one wire per button for memory control and panel lamp tally. This is referred to as the LAMP/CONTROL signal. The single-wire concept represents a departure from past practice where one wire from the button to the switcher was used for signaling and another wire from the switcher to the button operated the lamp. Combining the two functions on one wire simplifies the panel wiring almost 50%.

Fig. 6 depicts the control-panel wiring scheme used for the TS-51. Switches S1 through S16 are interconnected for a typical output row of a switcher. It can be seen that a panel tally lamp can be activated either by pressing an appropriate switch at the panel or by providing a transistor closure to ground through the LAMP/CONTROL wire.

The TS-51 uses a two stage IC memory and a once-only (single transfer) trigger system. This choice is based on the following considerations:

- 1) The switcher must operate reliably regardless of noise due to button chatter.
- 2) Output rows 3 and 4 should have the capability to transfer their storage as either a preset-take or flip-flop operation.
- 3) The video crosspoints should always perform an overlap type switch.

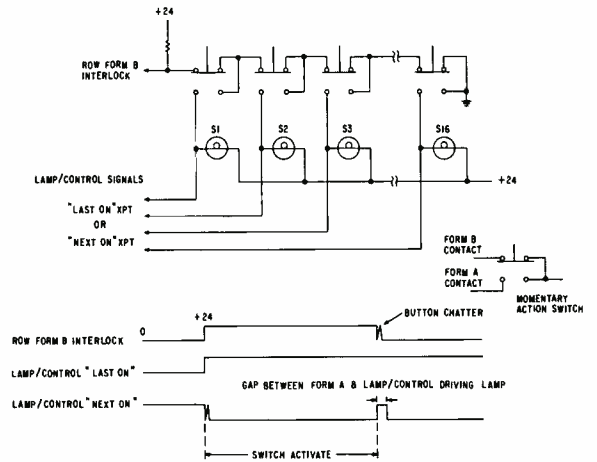

Fig. 6—Timing sequence and waveforms for single-wire control system.

A logic diagram and signal timing waveforms for a typical memory element are shown in Fig. 7.

The PICK UP, CLEAR, and DROP signals are sent to each memory element of the switcher grid on a continuous basis, once every vertical interval. A given CLOCK PULSE signal is associated with only one output row. The clock pulse signal is comprised of two parts: the switch-cycle pulse and the 200-kHz trigger pulses. The switch-cycle pulse is sent as a continuous signal; whereas, the 200-kHz trigger pulses are gated ON each time a button is pushed to provide once-only operation of the switcher.

The first stage performs two functions. It acts as a filter to eliminate problems caused by pushbutton bounce and it performs the pre-storage required when information is to be transferred between the third and fourth output rows. Transfers of this type are referred to as *cut bar control*. Most program assembly switchers require this feature.

The second stage is used to provide both a controlled overlap switch and long-term storage. A high-crosspoint hold signal from the second stage will turn the video crosspoint ON, while a low signal keeps it OFF.

APL CORRECTOR

The new switcher eliminates shifts in blanking and sync-tip levels. These shifts always accompany a direct switch between two AC-coupled television signals of different average picture levels (APL). Transfers between all white and all black signals (Fig. 8) produce the largest possible steps in blanking and sync-tip levels. Transfers between signals of intermediate APL's produce smaller steps.

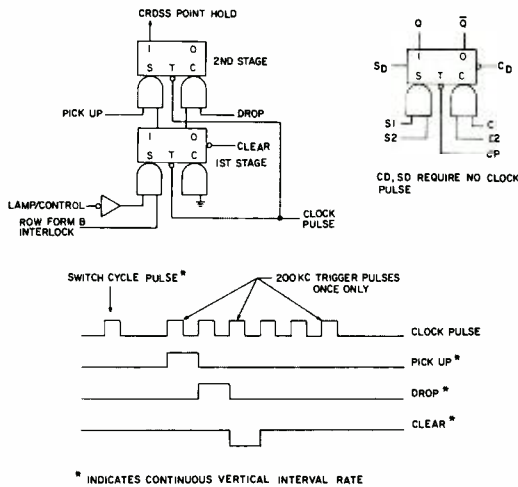

Fig. 7—Typical two-state memory.

The most serious problem caused by these steps in blanking and sync tips is that they often create transients in sync separation circuits that are based on some type of DC restoration or level-sense comparison. Many current-day monitors, sync generators, video-tape machines, and stabilizing amplifiers use sync separators of this type. It is significant to note that the type of direct switch referred to is the sole source of this type disturbance. A sudden change in scene content in front of a given camera does not produce the same effect. The difference is that the camera is designed to maintain the blanking level as a fixed reference; whereas, an AC-coupled system uses the AC axis as its reference.

A practical programming requirement for a video switcher is the ability to switch a signal on itself. Under this condition small shifts, due to parts tolerances and thermal conditions, are easily visible.

The TS-51 video switcher includes an automatic APL correction feature which eliminates the immediate shift in blanking and sync-tip levels normally accompanying a direct switch between two AC-coupled video signals of different APL, and eliminates a similar shift which frequently accompanies a switch on itself which is caused by DC errors through the crosspoint.

The APL corrector (Fig. 9) may be described as follows:

Transistor *Q1* operates in conjunction with capacitor *C1* to form a simple shunt clamp. Clamping occurs during the interval between two horizontal sync pulses on one of lines 14 through 20 after the vertical interval. The duration of the clamp time is approximately 50 μ sec. Prior to switching, the clamp will have DC restored the video signal at point *B*, so that its blanking reference is at ground potential.

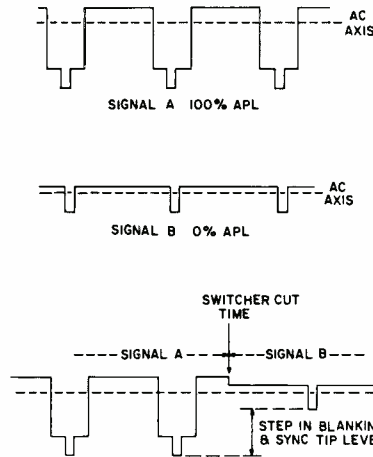

Fig. 8—AC switch.

The switch is timed to occur 5 to 10 μ sec after the leading edge of the clamp pulse. At this time, the discontinuities in blanking and sync-tip levels are presented at point *A*. The source of this signal is the low-output impedance, "last on" and "next on" crosspoints. Since the clamp is on at the time of the switch, the signal waveform at point *B* is a simple differentiation of the step presented at *A*. Resistor *R1* and Transistor *Q2* then act as an attenuator to reduce the amplitude of the differentiated signal at point *C*. Therefore, at point *C* the switcher has done exactly what the camera does, it maintained blanking level as a fixed reference. However, since the TS-51 uses an AC-coupled output amplifier, the output signal must maintain the AC axis as its reference. This means that after the switch, the output signal will exponentially recover the new AC axis. The time constant for this recovery is approximately 0.7 seconds.

Although the waveforms of Fig. 8 represent a positive-going discontinuity, negative steps are differentiated and attenuated in the same fashion. The APL cor-

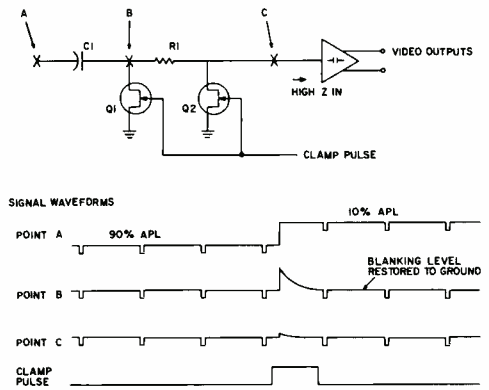

Fig. 9—APL corrector.

rector requires both the precise control of switching time and the sync sense information built into the TS-51 switcher.

CONCLUSION

A significant achievement has been made both in packaging and performance. The performance values of Table I illustrate the complexity of measurement and the close tolerances required for broadcast service. All solid-state components were chosen as the state of the art permitted—ranging from digital control and holding circuits using IC's to wideband highly linear video amplifiers using the latest silicon transistors and high-current, low-cost transistors replacing relays in lamp indicator circuits. All of this is packaged in rack frames far more compact than previous models yet quite flexible in adjusting to a wide variety of system configurations.

TABLE I—Performance Figures for a Single Pass through the Main Grid of the TS-51

Frequency response (any input to any output)	1. 50 Hz to 8 MHz: ± 0.1 dB (ref. at 15,750 Hz); 8 MHz to 12 MHz: less than +1.0 dB down; above 12 MHz: smooth rolloff.
Path delay difference (any two inputs at an output)	2. Square Wave: less than 1 percent tilt or bow at 50 Hz;
Crosstalk (the unwanted signal on all inputs and outputs except the ones under test)	Less than 1.0 degree at 3.58 (0.75 nsec).
Differential gain (amplitude modulation of the chrominance signal by the luminance signal)	60 dB below 1.0 v(pp) at 15,750 Hz; 45 dB below 1.0 v(pp) at 3.58 MHz; Increasing no more than 6 dB per octave above 3.58 MHz.
Differential phase (phase modulation of the chrominance signal by the luminance signal)	10-90 percent APL at 3.59 MHz; 0.3 percent maximum distortion for a 1.0 v(pp) composite video signal.
	10-90 percent APL at 3.58 MHz; 0.3 percent maximum distortion for a 1.0 v(pp) composite video signal.

AUDIO DISTRIBUTION BY CARRIER METHODS

Elaborate audio processing and distribution facilities are often required in closed-circuit television systems to allow for complete programming capabilities. A system which provides for multiplexing audio signals with video, allowing single-cable distribution, materially reduces the cost of processing and distributing audio signals. This paper describes the salient functions which such a system must perform and, based on these performance criteria, discusses the development of an FM carrier approach to the system. Video/audio interference problems are discussed and design compromises for an optimum system are developed. Block diagrams and performance results of a developmental system are given to demonstrate the feasibility of the system.

R. W. JORGENSEN

*Burbank Engineering Section,
Broadcast and Communications Products Division, Burbank, Calif.*

CLOSED-CIRCUIT TELEVISION systems generally involve signal distribution across long distances or throughout an entire building. When program material requires both picture and sound, each signal must be processed and distributed by a separate and completely different system, and each system must provide a quality signal with attention given to maintaining proper levels, correct impedances, and minimum interference. In addition, provisions for routing and installing two sets of cables must be designed into the system. Analysis of these dual requirements for program distribution from the standpoints of system cost and installation complexity becomes increasingly difficult as systems become more elaborate and require greater flexibility. In many closed-circuit systems the audio and video signals are distributed by circuits which run in parallel paths from the program switcher or, in many cases, from the program source to the intended audiences at remote receiving areas. This being the general case, the development of a system for combining video and

audio signals for transmission via the video system is not only credible, but has many aspects which lend economic feasibility. The system described in this paper involves multiplexing the audio signal with the video information using frequency modulation. The approach is to insert an FM carrier beyond the normally used spectra of the video information thereby assuring transmission of a high quality audio signal with minimum mutual interference between picture and sound. Although limited to wideband television systems, this approach can be both economical and flexible.

EARLY CONSIDERATIONS

Several application possibilities became apparent in approaching the development of this system. Fig. 1 shows two methods in which the carrier would be utilized and also shows a number of program sources requiring audio and video distribution capabilities.

In method A, FM transmitters multiplex the audio and video signals at each program source. In this manner, selection of a program source by the video switcher provides for audio-follow operation without special audio switching

facilities. The multiplex signal is then distributed by the video system to FM receivers which demodulate the sound and allow the picture to pass to a monitor. In this application, several transmitters would provide single-cable distribution throughout most of the system.

A less extensive use of the multiplex system is shown as method B. Here a single transmitter multiplexes the audio and video after the signals have been processed for transmission. This multiplex system replaces only the audio distribution equipment, and conventional processing and switching facilities are required to combine the proper signals for multiplexing in the transmitter. Although the second method would most generally be the more economical of the two systems, the installation conveniences and savings effected in audio processing facilities lends feasibility to the approach of method A.

DESIGN APPROACH

Generally, closed circuit television installations are broadband, high resolution systems which are compatible with the requirements of an FM multiplexing scheme. However, although usable dis-

Final manuscript received October 9, 1967.

Fig. 1—Possible applications with which the audio/video distribution system must be compatible: method A provides single-cable program distribution throughout an entire installation; method B provides single-cable distribution after switching and processing of signals by conventional equipment.

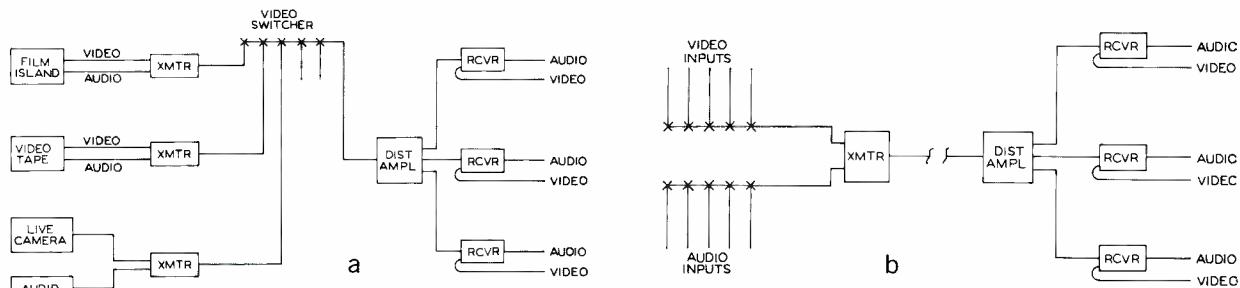

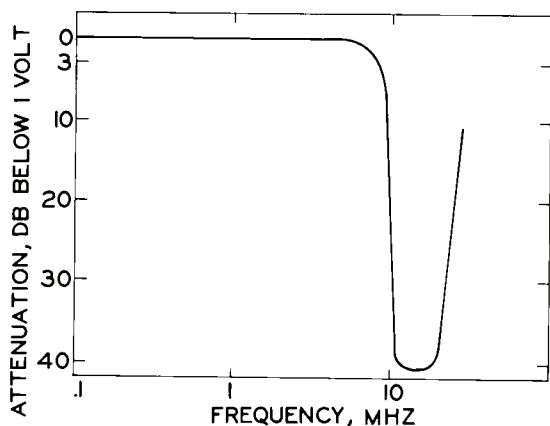

Fig. 2—Amplitude response of the video filter providing 650-line bandwidth for the video system and protection from mutual-signal interference.

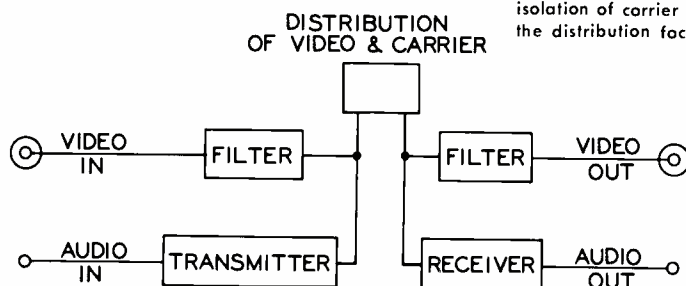

Fig. 3—Basic system approach showing filter isolation of carrier within the distribution facilities.

tribution bandwidths beyond 10 MHz are available, many video sources have substantial energy components in this area. To insure adequate transmission bandwidth for the inserted carrier and to avoid mutual interference between signals, filters were employed to restrict the high end of the video spectrum.

Active notch filters were not useable in this situation due to requirements that the multiplex system should not affect such system parameters as differential gain and phase. The design of a crystal filter was found to be too costly for this application. Final evaluation led to the design of a 75-ohm, passive filter network utilizing a modified Butterworth prototype model. This filter yields adequate low-pass results in the region of 8 to 10 MHz. The amplitude response of the final filter design — which requires three inductors and three capacitors — is shown in Fig. 2. The allowed video bandwidth of 8 MHz provided for a high quality 650-line video signal and injection of carrier frequencies beyond the 10-MHz region provided for adequate isolation from video information to insure minimum interference.

Adoption of the 8-MHz low-pass filter set up a frame of reference for subsequent development of the essential components for the multiplex system. The block diagram of Fig. 3 shows the form adopted for the system. Incoming video was to be rolled off sharply at 8 MHz and a transmission carrier added to the distribution line. At the end of the system, the carrier was to be demodulated by a receiver and the video passed through another filter to remove carrier interference. The choice of optimum values for center frequencies, carrier levels, and receiver sensitivity involved a number of system compromises.

RECEIVER AND TRANSMITTER DESIGN

The typical applications for the multiplex system, as described earlier, could be expected to require more receivers than transmitters. Based on this assumption, it seemed desirable to build an inexpensive receiver utilizing the minimum circuitry necessary to demodulate the signal faithfully (Fig. 4). A single integrated circuit was employed to amplify and limit the carrier and to detect the intelligence. A doubled-tuned input

transformer and a phase-shift transformer were the only other major components necessary in the design.

A prototype receiver was built and it was found that commercial 10.7-MHz transistor IF transformers were capable of performing with nearly equal quality at center frequencies ranging from 9 to 12 MHz. Further measurements on the receiver revealed a sensitivity of 10 millivolts as the threshold of limiting. As performance was degraded below this level, a 100-millivolt carrier level (20dB into limiting) was specified to allow for distribution losses and to improve performance. Measurement of the capture ratio for the simple design yielded results which are not uncommon for wide-band low-selectivity receivers. Measurable interference by frequencies common to the carrier started at levels as low as 15dB below the carrier and approached complete paralysis of the receiver around 3dB below carrier level. To avoid possible video interference of this nature, the carrier frequency was set at a point where filter attenuation assured at least 40dB isolation from video signals. The final carrier frequency was set at 11 MHz to allow for a 6-dB margin of error. Full amplitude 11-MHz video of 0.7 volts thus allowed a worst-case amplitude of only 7 millivolts. At the video output end of the system, the 100-millivolt carrier would be attenuated to 60dB below the video signals passed through the filter.

The transmitter design was based on a Colpitts oscillator and a varactor diode. Modulation of the oscillator collector-base depletion area capacity as well as the varactor diode in the tank circuit yielded increased modulation sensitivity which served to reduce production-line variations and to reduce incident AM of the carrier. An emitter follower and a reactive network served to match the carrier to the line and to unload the oscillator from line capacity and impedance variations. As a wide range of audio levels would be presented to the system, a level control and two-stage preamplifier were needed to allow adjustment for proper modulation level. A portion of the preamplifier signal was

Fig. 4—Essential function required for FM demodulation. The low-pass filter simulates a de-emphasis network, but is necessary for transceiver applications.

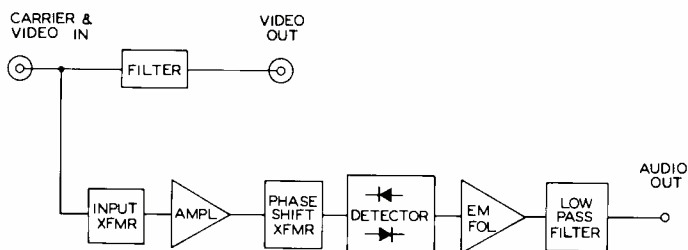
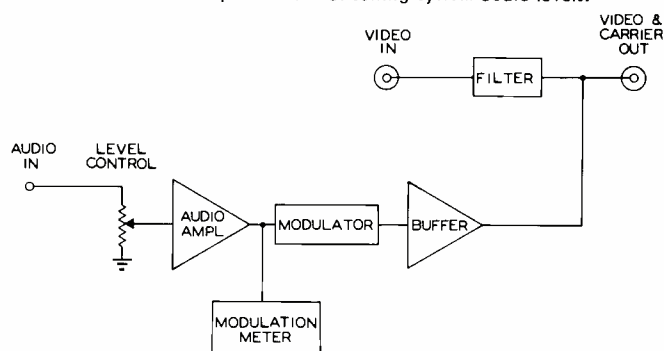

Fig. 5—Functions provided in the transmitter. The level control and modulation meter permit ease of setting system audio levels.



rectified and applied to a meter calibrated in KHz carrier deviation. A simplified block diagram of the transmitter is shown in Fig. 5.

TRANSCIVER CONSIDERATIONS

With the basic components of the system having been completed, an extension of capability which allowed for two-way audio transmission seemed apparent. Although limited to bi-directional transmission systems, applications where exchange of responses and data are required between transmit and receive ends of the system, while video information remains unidirectional, are not uncommon; notable examples being school systems and certain industrial applications.

Unfortunately, the simple receiver developed for the system did not provide adequate selectivity to allow closely spaced carriers. The effect of 20dB of limiting at the receiver input required carrier separations in excess of 500 KHz. Since increased selectivity could be obtained only by adding a tuned non-limiting stage to the input, the second carrier for two-way operation was placed at 12 MHz to save the added cost. This 1-MHz carrier separation was found to give adequate guard band to allow for errors in system misalignment.

PRELIMINARY RESULTS

Initial testing of the receiver showed that the integrated circuit limiter-detector exhibited harmonic distortion exceeding 3%. Redesign of the receiver using discrete components in a ratio-detector circuit reduced audio distortion in the system to approximately 1%.

Temperature runs performed on the FM transmitter indicated that compensation of the carrier oscillator would be required. Zener-diode biasing gave adequate compensation to hold carrier drift within a range which would add roughly another 1% of audio distortion.

Signal-to-noise measurements were found to be in the order of only 40dB below rated output. Improvements to the transmitter preamplifier and reduction of the conversion gain of the modulation-demodulation process reduced the

final figure to greater than 55dB below rated output.

Interference in the form of incidental FM caused by differential phase in the distribution system was found to be negligible under worst-case conditions. A low-pass filter was added to the receiver output to remove a 1-MHz carrier beat frequency when two-carrier operation is utilized. This filter also served to reduce noise components outside the audio range; further improving measured receiver performance.

SYSTEM PERFORMANCE AND COMPATIBILITY

The final system design evolved into a high quality, economical system. Measured performance curves for the transmitter and receiver shown in Fig. 6 indicate that a linear transfer characteristic extends to 150-kHz deviation. The adoption of 75-kHz as the maximum deviation level assures ample provisions for carrier drift and for handling peak program material. Audio response measurements depicted in Fig. 7 show the final system distortion over an audio bandwidth of 20Hz to 20 kHz. Additional bandwidth beyond 20 kHz is available should AM subcarriers for cue channels or control features be required in system applications. The input level control and transmitter pre-amplifier allow for levels ranging from -40dBm to +25dBm (bridging in from a 600-ohm line) to be handled in the system. Overall system gain at 75 kHz is 30dB, producing an output level of -10dBm or 250 millivolts RMS into 600 ohms. At 150-kHz deviation, a maximum level of 500 millivolts is available at less than 3% distortion. Signal-to-noise measurements under worst-case conditions is more than 55dB below rated output. Although pre-emphasis and de-emphasis

networks tend to improve the s/n ratio, the inherent boosting of the high frequencies adds distortion unless the overall modulation level of the system is lowered. By simulating the weighting effect of a de-emphasis network with the beat-frequency filter on the receiver output and by maintaining the higher modulation level, fairly low noise performance at lower distortion is possible. This approach assures an optimum signal-to-noise and distortion ratio. Applications of the system in video systems require only that the connections in and out of the filters be terminated in 75 ohms. Performance tests of the filters with 500 feet of RG-59/U coaxial cable produced no observable reflections on a 10-MHz sweep envelope. Audio performance remains essentially unaffected over transmission lines in excess of 1500 ft. Operation beyond this length is possible; however cable attenuation of the carrier level requires more exact alignment of the system, and once out of limiting, the signal exhibits increased noise and distortion.

CONCLUSIONS

The evolution of the FM multiplex approach to single-cable program distribution was based on preliminary investigations of other approaches to the problem. The method of injecting a suppressed-carrier SSB audio channel between harmonic energy bunches of the video spectra, although quite applicable to systems with narrow bandwidths, was found to be limited in audio quality and to require precision components to avoid interference. Other popular schemes were likewise discarded due to either limited audio quality or system complexity and cost.

Optimum economics and flexibility of the multiplexing approach can be applied only where sufficient bandwidth is available to allow compromises which offer minimum degradation to video system capability and still allow for protection against mutual interference. These provisions being justified, the quality of the single-cable system audio channel is dependent only on the design of the modulation and demodulation circuitry.

ROBERT W. JORGENSEN worked as a student engineer for the Broadcast and Communications Products Division in Burbank during the summer of 1964. After receiving the BSEE at the University of Idaho, he was assigned to audio and video projects in a design engineering capacity. Active in the student branch of IEEE and Sigma Tau while in school, he is now a member of the IEEE, SMPTE, and the Audio Engineering Society.

Fig. 6—Transmitter and receiver input-output characteristics depicting linear operation to 150-KHz carrier deviation.

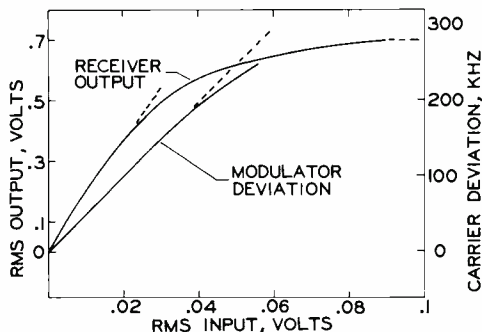
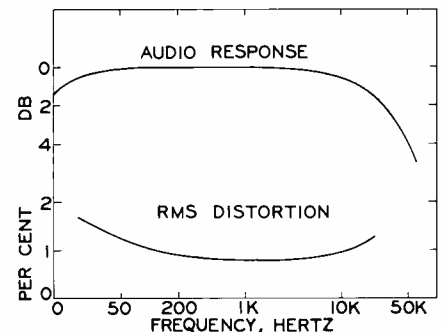

Fig. 7—Audio bandwidth and distortion measurements of the system. Response out to 50 KHz is available for additional information uses.



NEW TELEVISION AUDIO CONSOLE

This paper describes the design of a modern television-audio console capable of handling both simple and complex programming requirements. The routing of the multitude of inputs, special effects switching, previewing and other control functions are described.

HENRY KROCHMAL
Audio/Video Engineering
NBC, New York City

PRESENT-DAY audio requirements for television studios far exceed those of just a few years ago. Not only is there a need for handling more input sources, such as a multiplicity of microphones, turntables, tapes, films, video-tape, audio feeds, and incoming-remote feeds, but also a need to create a number of special but related output program feeds.

SPECIAL REQUIREMENTS

For example, remote operation of tape machines and turntables must be provided: Special-effects switching, incoming-circuit switching, switching of groups of faders into sub-master circuits, monitoring of various circuits, such as the previewing of incoming circuits, turntables, tape machines, feedback circuits and echo circuits should also be provided. The ability to simultaneously switch audio and video signals should be considered.

A program console should have built-in video monitors for program and preset continuity. The level of monitoring

Final manuscript received September 27, 1967.

speakers should be controllable at the console. The console should be equipped with a comprehensive intercom and interrupted feedback (IFB) system to maintain verbal contact with all members of the operating and producing unit. With all these requirements in mind, a new audio console was developed by NBC for use in television studios.

THE CONSOLE

The audio console system comprises three control panels; a wing section; and four standard racks of preamplifiers, program amplifiers, and other associated equipment (Figs. 1 and 2). These amplifier racks are located near the console. Audio-patching jacks are of the single-tip ring-and-sleeve type and are all located in the racks except for tie-trunk jacks located in the wing section. These can be used to connect additional portable operating equipment to the circuits in the racks.

The console proper contains few audio circuits; in contrast to the normal audio console using conventional microphone faders, the faders used in this

console are actually simple DC controls, operating a light-control fader system which is an integral part of each pre-amplifier assembly (Fig. 3). This arrangement greatly reduces the customary undesirable conditions of AC hum and noise pickup, and furthermore, simplifies console wiring and maintenance.

Each of the three control panels in the console contains 14 slide actuators for a total of 42 microphone faders. The wing section houses the delegate switches which are used to assign the 42 microphone faders in any combination to the 5 sub-master mixing buses. Above each slide actuator is a vertical row of 5 colored tallies to indicate sub-master assignment. Immediately below the center panel slide actuators are 5 rotary sub-master actuators with colored knobs to match the assignment tallies.

The delegate push-switches operate the audio mixing relays located in a rack, as well as lighting the proper tallies on the console. The 5 sub-masters are mixed and fed into a microphone master located to the right of the sub-master. Directly above the assignment tallies in each slide-actuator row is an associated individual microphone-echo fader. Simultaneously with the assignment of a microphone fader to a sub-master mixer, the echo fader is switched to one of 5 echo-mixer sending buses.

A nemo switching system of 20 inputs is located in the upper left-side position of the center panel with the associated nemo master level control located to the extreme left of the microphone sub-masters. This system is used to process, on a switching basis, the incoming feeds, such as remotes, film and video-tape sound feeds. Inputs to the nemo system terminate in jacks in the audio jack field of TV master control and are normalled to provide a parallel path to the studio

Fig. 1—Front view of the audio console.



Fig. 2—Associated turntables, tape recorders, and cabinet racks containing amplifiers.



camera switching crossbar, so that simultaneous tracking type of audio-video switching is possible.

Two effects-preset switching systems (8 input by 3 output each) are located in the upper-right panel. These effects switches are co-ordinated with camera and microphone switching and are used primarily to obtain special dramatic effects such as would be required for the ordinary telephone conversation.

There are four turntable/tape switches to remotely operate turntables and tape machines. These switches are three-position lever key type to achieve stop-start action in either the audition or program mode. Tally-indicating-type push-keys located above the lever keys provide a preset facility for tape machines in the record mode. The audio circuit configuration is such that the input to the tape machines is always connected to the program bus to achieve continuous recording of audio program without auxiliary patching.

The console also contains two utility switch circuits, four microphone equalizers, two compressors and two program equalizers each with a telephone filter system, all of these facilities on a patchable basis.

Two 8-inch video monitors are located in the upper-center panel for program and preset continuity. The program VU meter is in the center panel between the two video monitors.

The output of the console is fed into two program amplifiers (regular and emergency) each adjusted for +4 vU output at 15-ohms impedance feeding interconnecting trunks to TV master control room. The return circuit (program bus) to the studio control room is fed to the program VU meter and monitoring speaker. In the event of regular program amplifier failure, the transfer to emergency equipment is by relay control.

A very important feature of the console is the ability to provide five separate tailor-made feedback programs in addition to the regular program. This mix-feed system consists of a 6-input by 5-output switch group for controlling relays and amplifiers in the racks; these switch groups are located in the upper-right console panel. The feeds to the switch group are from distribution-bus amplifiers which are parallel fed from the sub-master and nemo mixing networks and are simultaneously controlled with the microphone and nemo sub-master actuators. The circuits feeding the mixing switch group are sufficiently well isolated that it is impossible to get undesirable backfeeds regardless of the switch-group combination. Located just to the right of each horizontal row of the switch group are level controls for the associated group-line amplifier (Fig. 4). The output of these amplifiers are available in TV master control for interconnection to outgoing circuits in accordance with program requirements. Once the mix-feed level controls are properly adjusted, the tracking of levels is automatic. Any change of microphone faders, sub-master, or nemo-level controls that affect the regular program bus will also have the same effect on the mix-feed buses. A similar switch group having 6 inputs and 7 outputs is provided for feeds to the studio PA system.

A pushbutton, category-number, monitoring-selector system with VU meter is located in the upper right of the center panel and provides means for checking level and sound quality on any of the incoming circuits, sub-master boosters, turntables, tape machine outputs, mix-feed buses, PA mix feeds, echo send, echo return, regular and emergency program amplifiers.

The console is equipped with a communications system including micro-



HENRY KROCHMAL graduated from Devry Institute, Chicago, Illinois. From 1943 to 1950, he was engaged in the design and construction of special test equipment at RCA Victro Tube Division in Harrison, N. J. He joined NBC in 1950 and worked in the Maintenance and Operations activity until 1961. He is presently engaged in audio system design and engineering. Mr. Krochmal is a Member of the Audio Engineering Society.

phone and speaker for talkback to the studio and other control room areas. Other portions of the communications system include the conventional engineering headset system. The complement of monitoring speakers includes the normal program speaker, preview speaker, turntable/tape-cue monitor and director-cue speaker.

ASSOCIATED EQUIPMENT

The console actuators are light-controlling potentiometers with the lamps and light sensitive resistors (LDR) located in the racks (Fig. 3). All of the preamplifiers and boosters are plug-in and each preamp card includes a transistorized amplifier and two sets of controlling lamps and LDR's, one for the regular microphone and the other for the echo system. The audio system is 100% transistorized.

Fig. 3—Simplified light-controlled fader system.

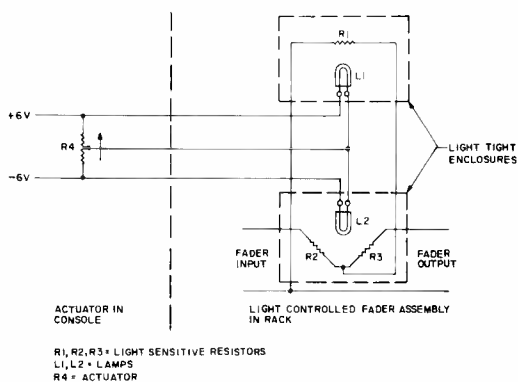

Fig. 4—Simplified diagram of mix-feed system.

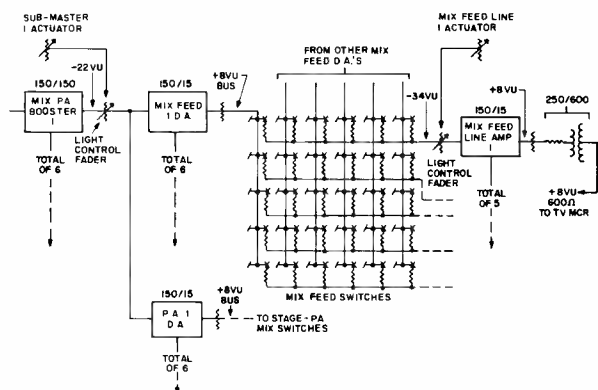



Fig. 5—A typical studio (48 ft. x 96 ft.) involves placement of loudspeakers, video monitors, and microphones, and the coordinated control of all functions.

The studio PA system for a studio measuring 48 feet by 96 feet includes 28 low level speakers suspended from the ceiling in 7 rows of 4 speakers each (Figs. 5 and 6). Each row has individual driver amplifiers and a level control is provided for each speaker within the row. The low level type of sound distribution employing a multiplicity of speakers properly located has been the only satisfactory method of sound reinforcement in an audience type television studio. This type of system also provides in the large TV studio good actor-sound reinforcement. The PA console, which is located in the rear of the audience area of the studio, includes 12 patchable faders, and visual monitoring and can feed any combination of rows of speakers in the studio area (Fig. 7). Facilities are provided for control of the PA system at either the PA or audio console.

Nine applause or audience-reaction microphones are suspended from the ceiling above the audience seating area and appear as an output in the control room. Evenly spaced around the perimeter of the studio walls approximately 2½ feet above the floor are outlet boxes each containing 10 microphone outlets, program headset outlets, interphone and spare trunk outlets.

There are two desks in the production control room—the regular production console which includes the technical director switching panel and a separate desk which is called the VIP console (Fig. 8). These desks have various monitoring and communications panels as well as the muted 10-position IFB (interrupted feedback) switching system. The 10 IFB circuits into which the program or mix feeds are fed can be interrupted at any time with a talkback microphone which is under control of the program co-ordinator. Also in these desks are located four 30 position monitor speakers in which various studios and channels can be monitored, four 10 position incoming circuit monitors (normally

associated with the outgoing IFB system), four patchable muted 10-position low-level circuit monitors, five individually patchable circuit monitor speakers, one telephone type dial office monitoring selector system and a number of telephones.

CONCLUSION

The development and design of this console is the result of many years of operation experience with the comparative simple type of shows such as a routine news program as well as the more complex dramatic and variety presentations such as the Hallmark and Perry Como

shows. It is a fact that with the average simple type program many of the features in this audio system are not required. However, it was deemed advisable to provide a system capable of not only handling present day shows but to anticipate requirements ten years hence. The physical layout has been made to provide for the greatest convenience and flexibility of control according to function. One of the more unique features of the system is the remote operation of the faders and is one of the important factors contributing to the high degree technical performance of the overall audio system.

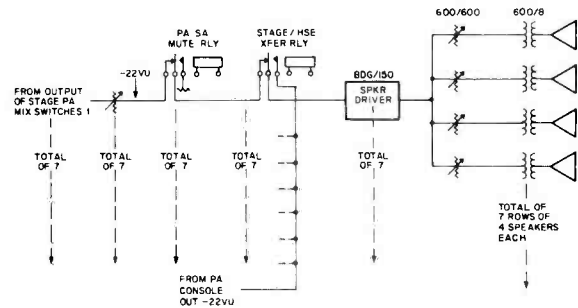

Fig. 6—Simplified diagram of studio PA system.

Fig. 7—Power amplifier control console provides fader and monitoring facilities.

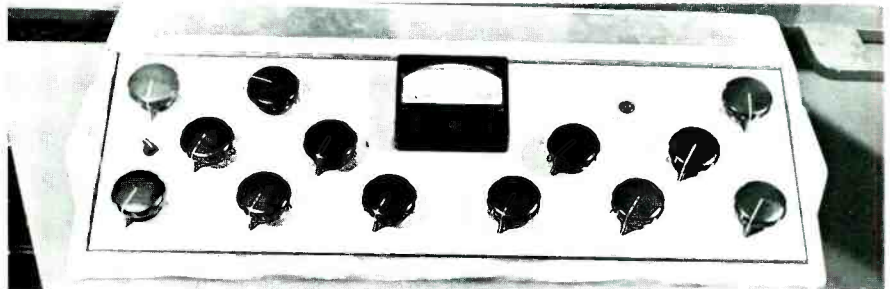

Fig. 8—This "VIP" console contains monitoring, communications, and switching facilities.



AUTOMATIC AUDIO SIGNAL PROCESSING

Over the past several years there has been increasing activity in automatic station operation. Completely automatic station activity necessitates the use of some form of automatic gain-controlling equipment to maintain a uniformity in peak and average signal levels presented to the transmitter. Increased demands on audio signal processing equipment brought about by a large variety of input sources (tape, film, records, microphones, lines, etc.), increasing demands for wide coverage, high quality reproduction, and stringent requirements by the FCC with regard to overmodulation in FM and TV broadcasting have brought about the need for a new generation of automatic audio signal processing equipment.

RICHARD F. ABT

Audio Engineering

*Broadcast and Communications Products Division,
Meadow Lands, Pa.*

THE RECENT TREND in audio-signal processing has been to automatically control the gain-riding function—once a manual task. With the realization of almost fully automatic station operation, i.e., playing preprogrammed selections and commercial messages, the burden on the signal processing equipment has increased.

Since signals from many sources must be accommodated, a standard transmission level of, say, 0 dBm, may fluctuate as much as 10 dB higher or lower. In an automated station, the job of maintaining a constantly high average modulation level is accomplished by an AGC amplifier. Due to the inherent restraint placed on AGC amplifiers that they perform their gain-riding function in an inaudible manner they are, by design, slow acting. Attack and release times of AGC amplifiers, although somewhat adjustable depending upon the application, are slow in comparison with many instantaneous signal peaks. To maintain a high uniform modulation level and prevent fast acting peaks from overmodulating the carrier and causing interference, possible damage to the transmitter, and considerable distortion, a fast acting compressor is needed. This allows higher peak modulation levels for maximum coverage with low contributed distortion and little fear of overmodulation. These peak limiters are normally employed at the transmitter and were heretofore considered the answer to controlling overmodulation problems. Today, however, with continuing advances in both recording and broadcasting techniques, the high frequency content of program material is maintained and may cause overmodulation after pre-emphasis in FM-type transmission. The control of

Final manuscript received November 14, 1967.

this FM overmodulation problem has added a third audio signal processing chore to the traditional peak and average signal controllers.

To understand fully the problems encountered and the methods by which these problems are resolved automatically by signal processing equipment, let us consider each function and examine it closely.

AUTOMATIC AUDIO LEVEL CONTROL

With the onset of automatic station operation, the desirability of maintaining more uniform levels between program and commercial messages gives increased importance to automatic-gain-control amplifiers. To become competitive and realize a profit, a station, whether AM or FM, must achieve the maximum possible coverage. To achieve this, AGC amplifiers are utilized to accept various program material and keep the average level uniformly high with no manual gain-riding whatsoever.

FUNDAMENTAL AGC DESIGN CONSIDERATIONS

The function outline of any general compressor-expander or AGC amplifier is illustrated in Fig. 1. The main part of any gain-controlling system is the gain-controlling element. This element will control gain either by variable amplification (if it is an active network) or by variable attenuation (if it is a passive network). To control the action of the gain-controlling element, a signal must be provided which usually takes the form of a peak and/or average filtering of the rectified audio signal. This is necessary to keep the gain from changing as fast as the audio signal does thus preventing audible distortion. The basic amplifier provides an adequate level for extrac-

tion of a control signal and isolation for the gain-controlling element.

Control loops for an AGC amplifier are of two types: an open loop and a closed loop feedback control (Fig. 1). The necessity for two types of control stems from the fact that both gain expansion and gain compression are necessary to maintain high average levels without loss of control at high input levels or the increase of noise level during no-signal conditions.

Compression requires the use of a closed-loop or feedback type of control, which, being necessarily degenerative, will act to decrease the audio gain as the input increases. For example, a 10-dB increase in the input signal level will cause the output level to increase only 1dB. The signal is then said to have undergone 9dB of compression.

Gain expansion, however, is not degenerative and, therefore, requires an open loop control. Since the control is open loop, the output level and open loop gain are dependent on the input level. That is, an increase in the input level of 3dB at any level above the expansion threshold would result in an increase of 6dB at the output. The signal would then be said to have undergone 3dB of expansion.

Compression may also be accomplished using an open-loop arrangement with the control signal made inversely proportional to the input signal level to give gain compression with increasing signal level. This type of approach suffers from an irritating effect known as "ducking" which occurs when the gain is allowed to drop more than the input signal rises. The result is a drop in output level. This effect is overcome by using a closed loop type control which is degenerative and is free from overcompensation.

The design and use of AGC equipment for stereo programs requires especially careful attention. The stereo presence, or apparent left-right positioning, is derived from the relative phase and amplitude of the right and left signals from the speakers. Most phase information is washed out by speaker placement and room acoustics, and stereo positioning is gained by the relative amplitudes of the two channels. To use an AGC amplifier in each channel would destroy these important amplitude ratios and thus stereo positioning would be lost. This problem is solved by having the same DC gain-control signal control both channels, thus preserving the relative gain between the two channels.

CHOICE OF GAIN CONTROLLING ELEMENT

Proper choice of the gain controlling element is essential to the performance

of the AGC amplifier. This choice could affect the distortion, frequency response, and noise of a given AGC unit. Some techniques result in unwanted additions to the program content such as low-frequency "thumping". This is brought about by allowing the DC gain-control signal to mix with the audio signal.

Two of the most popular gain-controlling elements are those which exhibit variable amplification and variable impedance. Variable amplification is accomplished by using remote cut-off tubes and transistors. They are operated so that their gain is a function of their bias. The obvious disadvantage here is that the control signal cannot help but be injected into the audio signal path. This will result in the above mentioned "thumping". Cancellation of this effect can be made using well-balanced, push-pull circuitry which would cancel the injected control signal at the plate or collector respectively. This adds uncalled for complexity in design with a resultant price increase for the buyer.

Variable-impedance devices such as diodes, light-dependent resistors, and tubes and transistors whose plate (collector) resistances are variable with bias may be used as shunt attenuators across audio lines. Series/shunt combinations are used when more operating control range is needed. Their operation in feedback loops is not recommended because of stability problems. The use of diodes for gain control has many problems. Since the diode impedance is very non-linear for very large signal swings (about 1 volt), considerable distortion occurs. To limit distortion, it is necessary to reduce signal level. When the signal level is of comparable amplitude to the gain control signal, the familiar "thump" is heard. Balanced

circuitry is the only answer and falls short of the mark when temperature variations tend to unbalance the diodes and permit the "thump" to be audible.

The light-dependent resistor (LDR) appears to be the near perfect gain controlling element. Its only shortcoming is a relatively slow reaction time (5-20 ms) and a slight sensitivity to temperature. As was mentioned before, AGC devices are inherently slow acting. Reaction time, therefore, is no problem. The resistive element is very linear and contributes little, if any, distortion. The gain controlling range is set by the range of resistance exhibited when the brilliance of the light is varied. The variation is usually about 10 megohms to 100 ohms with increasing brilliance. Complete absence of thump is accomplished by the electrical isolation of the gain-controlling element and the control signal.

Other methods of achieving AGC action such as analog chopping, variable duty cycle and RF conversion can be used but they are rather complicated and are mentioned here only for completeness.

ATTACK AND RECOVERY TIMING VS. DISTORTION

Instantaneous gain control such as by the use of peak clipping diodes, while exhibiting a type of AGC action (i.e., keeping the output from increasing with an increasing input) may give rise to high generated distortion. In other words, AGC action which allows the gain to vary as fast as the instantaneous amplitude of the signal may cause distortion. If, however, a capacitor is allowed to integrate the rectified audio signal to form a DC gain-control, AGC reaction time can be controlled and optimized with little or no distortion.

For compressor action in the AGC, the output level is to be maintained uniform with increasing input. To do this, the gain, and therefore the DC control signal, must follow the average signal variations, and the attack time must be slow enough to reflect true average of the audio level. For perfect averaging conditions, the attack and recovery times must be nearly equal. Attack times between 10 milliseconds and 5 seconds, and recovery times between 0.15 and 5 seconds are typical, depending on program content and personal preference. Expansion attack and release times are both approximately 5 seconds, again depending on content and preference. Slow expansion attack prevents low level signal from "rushing" up in gain and slow recovery time for compression prevents "gain pumping" or "swishing". These terms describe changing sound of background noise with rapid gain changes.

LEVEL VARIATIONS DUE TO PEAK-TO-AVERAGE RATIOS

The instantaneous peak-to-average ratio of an audio signal is quite variable. Fig. 2 illustrates the following example: For a sine wave, the average level is 4dB below the instantaneous peak level; but for a complex wave, the short time average may be 15dB below the peak. Limiting the instantaneous peaks to some level corresponding to 100% modulation, the short time average level of the program waveform may vary as much as 11dB, for example, depending on the complexity of the instantaneous waveform. The VU meter would indicate average readings from -5 to +6dB. Thus with certain program material or sine wave tone, the VU meter may read off scale by 3dB, while the peak level is controlled below 100% modulation by peak limiting action.

This brings about an interesting problem. Should the peak modulation be held to a maximum of 100% allowing the VU meter to vary up to 11dB or should the maximum VU reading be 0 VU which would allow instantaneous audio peaks to vary as much as 11dB, causing 100% to be exceeded? Here, the choice must be weighed against the consequences. Allowing peaks to exceed 100% modulation for the sake of keeping the VU meter constant and coverage maximum is a poor trade-off for FCC citations for over-modulation and the sacrifice in quality of the Broadcast Program.

There are some methods that may be applied to artificially distort the complex audio waveform to reduce the large peak-to-average ratio. Infinite peak clipping such as used in speech bandwidth reduction systems or high frequency roll-offs will reduce the peak-to-average ratio to 4dB in the limiting case. However, what may be lost, in addition to quality and tonal definition, is a large number of listeners.

What, then, is sacrificed by the use of AGC amplifiers to keep the long time average modulation high and the VU meters up scale, since the AGC amplifier does not affect the instantaneous part of the signal? It is program dynamic range. Since low level inputs around -10 VU are expanded to 0 VU, and high level inputs that would overdrive a VU meter by 10dB are compressed to a +1/2 VU reading, what would have been a 20dB dynamic range is now compressed into 1/2dB.

At first this would seem to produce a rather startling signal degradation and one that could most certainly be easily recognized. This, however, is not the case. Since the program material is still

RICHARD ABT received the BS in Electrical Engineering from the University of Pittsburgh in 1964. He then joined the Communications and Electronics Division of Philco Corporation as a member of the Advanced Speech Research Laboratory. He had early design experience in the area of speech processing equipment and speech privacy devices. In 1965 he was responsible for the development of a VLF communication system employing speech bandwidth reduction techniques for use by the Air Force. In 1966 he joined the RCA Broadcast and Communications Division at Meadow Lands, Pa. Since then, he has been engaged in the design and development of Broadcast Audio equipment; particularly signal processing amplifiers.



basically a complex signal, there exists as much as 11dB of dynamic range because of waveform variation as discussed before.

Secondly, listeners have become accustomed to judge dynamic levels not so much on a dynamic range, but on types of music and their associated dynamic range. Being previously conditioned by experience, the listener anticipates large changes of dynamic range for various types of music according to the tempo, the instrument, or the type of selection. Since 11½dB of dynamic range will be present by virtue of complex waveforms and the ACC action will have little or no distortion or degradation of frequency response, audio fidelity will not be impaired.

AUTOMATIC AUDIO PEAK CONTROL

It would seem that the obvious solution to the automatic level control problem is the ACC amplifier. Upon closer examination, however, it was previously noted that ACC amplifiers are restricted to reaction times that are relatively slow in comparison to possible instantaneous signal peaks. This was done to make their gain-riding function inaudible and relatively distortion free. What then is to be done to prevent instantaneous peaks from exceeding some previously set 100% modulation point and causing overmodulation of the carrier? One answer is to decrease the program level into the ACC amplifier. This would provide enough "head room" for fast peaks so that overmodulation would be unlikely. Consequently, this reduces the average level. For example, for a given amount of ACC gain expansion, a reduction of 6dB in average level results in a 75% reduction in the maximum allowable station power! To a competitive station, this solution would not be acceptable. Another solution is to clip all signal peaks above 100%, thereby providing complete protection while maintaining high average level. In keeping with high broadcast standards, the resulting distortion that this would produce on prolonged high level peaks prohibits this approach. What is needed then is some form of automatic sensing device that would detect fast acting, high level peaks and perform a gain compression function similar to that of the compressor in the ACC amplifier. This automatic peak controlling function is provided by a limiting amplifier.

To be effective, a peak limiter must be fast acting. This determines its ability to maintain even the fastest transients at an acceptable level. The flatness of its limiting curve (input/output characteristic) and contributed distortion are also of major importance.

Fig. 1—Block diagram of a general automatic gain-controlling system.

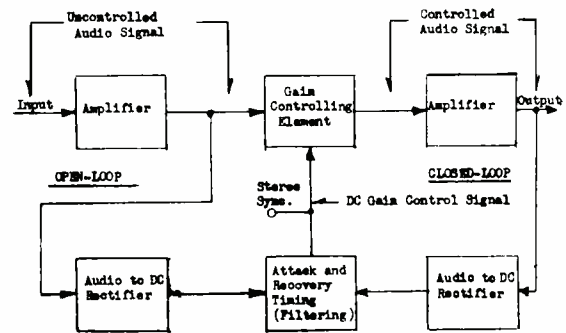

Fig. 2—Illustration of varying peak-to-average levels as a function of waveform.

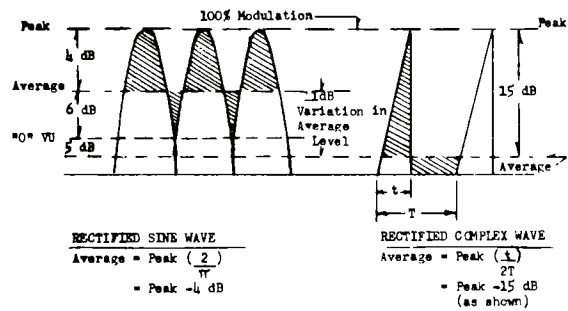

Fig. 3—Block diagram of an automatic peak controller.

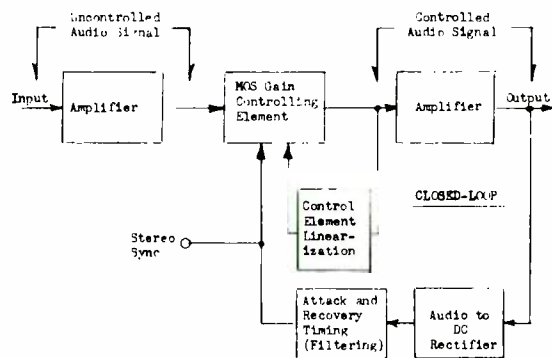
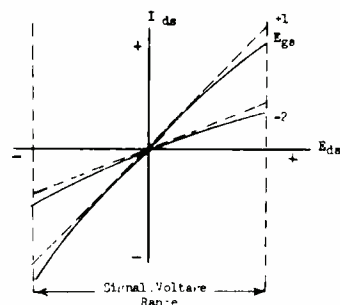

Fig. 4—MOS variable resistance characteristic.



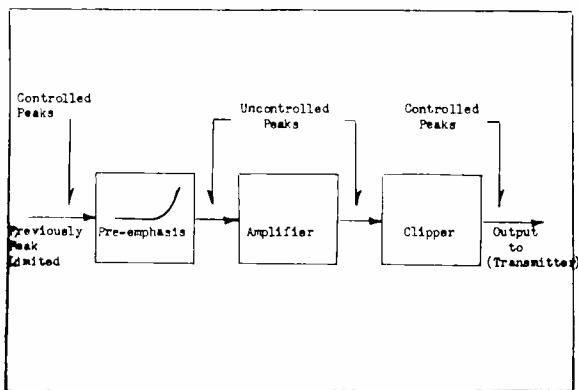

Fig. 5—Functional block diagram of peak clipper.

FUNDAMENTAL CONSIDERATIONS IN LIMITER DESIGN

Just as the compressor in an AGC amplifier must operate in a closed, degenerative control loop, so does the faster acting limiter. Using an inverse gain control function as the feedback control signal, a gain compression characteristic is obtained. The greater requirements upon speed of operation places more severe requirements on the gain-controlling element. As was discussed previously, the light-dependent resistor offered a large range of control and a built-in answer to "thump" in the form of an isolated control signal. To be an effective gain-controlling element for limiter applications, the LDR is too slow by a factor of 25 to 100.

With the development of the MOS field-effect transistor (MOS-FET), the potential of a fast acting control device with almost ideal characteristics was realized. With its insulated gate, the control signal is effectively isolated from the audio resulting in an inherently thump-free shunt-type limiting circuit. The essentially infinite gate impedance makes fast attack and slow recovery time constants easily obtainable.

Fig. 3 is the block diagram of a peak limiting system, employing a MOS-FET gain-controlling device. The MOS-FET is used in the shunt leg of a voltage divider and uses its variable drain-source resistance to provide attenuation. To avoid degrading the signal-to-noise ratio of the basic amplifier, the gain-controlling FET is placed at a point in the amplifier where the signal level is adequate to provide sufficient range of control without attenuating the signal below the amplifier noise level. Referring to Fig. 3, the only apparent difference between it and the compression circuit for the AGC amplifier (Fig. 1) is the addition of a control element linearization. The MOS transis-

tors exhibit non-linearities for high values of drain-source resistance as can be seen in Fig. 4. By feeding part of the audio signal into either the gate or substrate of the device a linearizing effect is produced. The dotted lines in Fig. 4 illustrate this linearization. Without this feedback, rather high harmonic distortion will be produced degrading signal quality during periods of rather light limiting.

ATTACK AND RECOVERY TIMING

At some set threshold, the audio signal is full-wave rectified and the resultant signal is peak detected. Peak detection is usually done by charging a capacitor through a diode providing a very low driving impedance and thus allowing fast charge-up. The charge-up of the storage capacitor will determine the attack time of the limiter since it, in turn, drives the gate of the FET. A slower discharge results when the diode becomes an open circuit allowing the capacitor to discharge through some large resistor. This longer recovery time (usually 1 to 5 seconds) is needed to prevent "pumping" or "swishing" up of background noise or low level signal immediately after a period of limiting. Stereo tracking of two limiters is accomplished in the same manner as that done with AGC amplifiers. The control signals of two limiters are tied together resulting in a common gate-control voltage applied to the FET in each channel. Slight adjustments may be necessary here to account for variations in FET parameters.

MOS-FET LIMITER PERFORMANCE

Using MOS-FET's as the active control elements, compression of 20 to 30dB into 0.5dB variation is easily obtained. Attack times are not specifically determined by optimum listening preferences, as may be the case with AGC amplifiers.

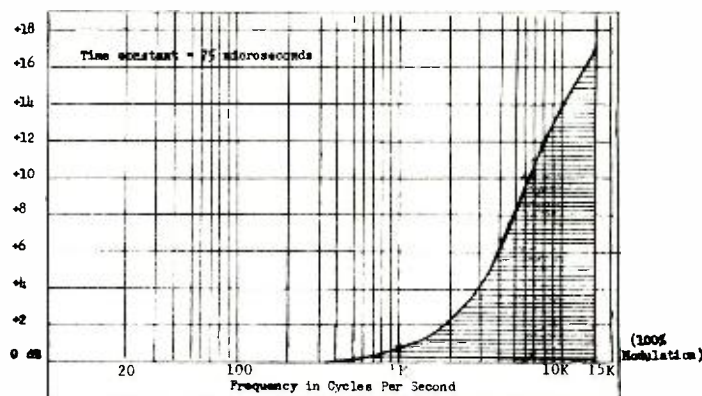

Fig. 6—Standard pre-emphasis curve.

Rather, they are as fast as capacitor charging limitations allow. A typical value of 200 μ s is not uncommon. By the use of a limiter after an AGC amplifier, average program levels may be increased without fear of overmodulation.

FM OVERMODULATION PROTECTION

Again, it seems that all functions of automatic audio signal processing may be accomplished by the combination of an AGC and a limiter. However, FM broadcasting presents quite a unique challenge to automatic signal processing. Due to an audio pre-emphasis, required by the FCC, a frequency-dependent overmodulation potential exists which cannot effectively be resolved by the aforementioned equipments.

CAUSE AND EFFECT OF PRE-EMPHASIS

An audio frequency spectrum of 30 to 15,000 Hz contains considerably less energy in the band above 1000 Hz as compared to the power content below 1000 Hz. Consequently, an improvement in the signal-to-noise figure could be realized by an attenuation of a previously pre-emphasized high frequency spectrum at the receiver. The 75 μ s pre-emphasis curve shown in Fig. 6 was adopted to be used previous to transmission. As can be seen from Fig. 6, the pre-emphasis curve is very severe. A flat input signal would receive 17dB of boost at 15 kHz.

Even though a fast acting limiter would maintain signal peaks at a uniform level, the following pre-emphasis will raise high frequency peaks more than those at low frequency by an amount equal to the pre-emphasis at that frequency. Feeding this signal into a transmitter theoretically could cause the maximum legal bandwidth of ± 75 kHz to be exceeded by about seven fold (± 525 KHz)! Although these extreme conditions

Fig. 7—Automatic gain-control action.

Fig. 8—Effect of peak limits.

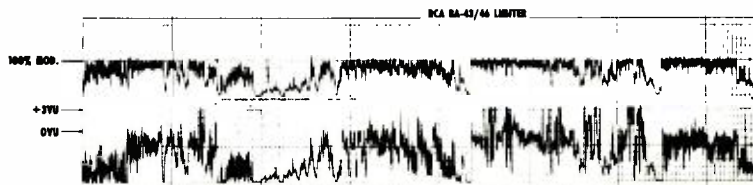
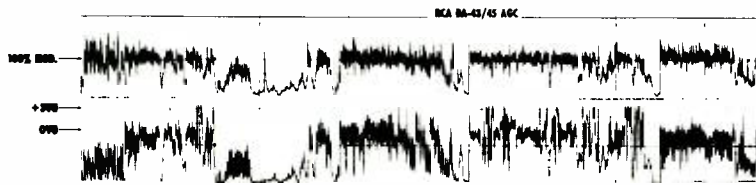

do not occur in actual practice, varying degrees of overmodulation and channel splasher are possible. Needless to say, this possibility coupled with FCC insistence that *no* peaks, of even short duration, exceed 100% modulation, has caused FM broadcasters no end of concern.

SOLUTIONS TO THE PRE-EMPHASIS PROBLEM

The first obvious solution to overmodulation is to reduce the modulation level. Reduction of level and, as a result, reduction of maximum allowable station power is, to the broadcaster, a solution of only passing interest. For modest protection against FM overmodulation with average program frequency content, a mid-frequency modulation level of 30% (or less) would be required. With this solution being more of an economic impossibility than a technological one, the possibility of using a peak limiter *after* the pre-emphasis offers another alternative. The use of a fast-acting limiter after the pre-emphasis does offer a reliable protection against overmodulation. This solution, however, is usually not desirable.

By pre-emphasizing peaks before the limiter, an exaggerated amount of limiting (gain reduction) will occur. This causes a reduction of the average modulation level. Certain types of programming could also cause audio "holes" as a result of exaggerated gain reduction followed by a slower limiter recovery time. The final affect is quite displeasing to the listener.

Since both of the above mentioned solutions affect the average level to provide protection against overmodulation, what methods will provide this protection with no loss in maximum allowable power? To accomplish this, only two methods exist; rolling-off of high frequency response, or by peak clipping.

High frequency roll-offs employ a type of frequency-dependent limiting that operates as a function of signal level. For example, as the program level gets higher, the high frequencies are attenuated. To obtain maximum peak levels for 100% modulation, the program material will undergo a roll-off starting at 2000 Hz (-3dB), and increasing to 15 kHz (-17dB). In other words, a complete inverse to the 75 μ s curve will be applied to the signal. This produces a flat frequency response, after pre-emphasis, to the transmitter. The

listener's receiver, however, has a complementary 75 μ s curve built in. The net result then is a severely degraded signal heard by the listener. Although this method allows high modulation levels with protection against overmodulation (still dependent on the limiter attack time) the tampering with the frequency response will, at higher modulation levels, cause a readily apparent loss of "high end" and brilliance.

Peak clipping provides absolute protection against overmodulation with the added advantage of no audible signal degradation. Fig. 5 shows a functional diagram of how peak clipping may be accomplished. The program material, having been previously peak limited, undergoes the standard 75 μ s pre-emphasis and is amplified to obtain a level suitable for the transmitter. At this point, high frequency peaks which were controlled by the limiter to some 100% peak value may now exceed 100% by the amount of the applied pre-emphasis (as much as 17dB). This uncontrolled signal, if allowed to modulate a transmitter, is an open invitation for a FCC citation. Now, however, the signal passes through clipping diodes that clip any peak in excess of 100% modulation by the amount of pre-emphasis it received (Fig. 6). The 100% modulation level is set by an arbitrary level from the peak limiter at some low frequency unaffected by pre-emphasis, say 400 Hz. Clipping may be done by zener diodes having a breakdown at the determined 100% modulation level or plain diodes back-biased to conduct and clip at 100%. This provides positive control with an attack time in the 1 μ s range.

While it is true that peak clipping does generate intermodulation and harmonic distortion, most of this distortion is removed by the 75 μ s de-emphasis network in the listener's receiver and the fidelity is preserved without resorting to frequency degradation. By subjective comparison, this type of automatic control not only provided absolute protection against overmodulation, but was preferred over the frequency roll-off method mentioned previously.

VISUAL ANALYSIS OF AUTOMATIC AUDIO SIGNAL PROCESSING EQUIPMENT

To demonstrate the effect of automatic signal processing on audio signals, a simple test setup was arranged to visually

display the influence of AGC, limiter, and peak-clipping equipment on peak and average levels. A record chosen for varied program content and wide dynamic range was used as a repeatable source. As this source was played and processed by each unit (i.e., BA-43/45 AGC Unit, BA-43/46 Limiter Unit, BA-43/47 Clipper Unit), the simultaneous peak and average levels were recorded by a chart recorder. The top channel in each chart shows the instantaneous peak level and a calibrated 100% modulation point. This may be considered as a recording peak-modulation monitor. The bottom chart shows the average audio signal level. This corresponds with a *visual* VU meter read-out.

Fig. 7 shows the action of an automatic gain-controlling device. The bottom curve has a well controlled average level (about 0 VU) but uncontrolled peaks exceeding 100% modulation.

Fig. 8 shows the effect of a limiter on the peaks. Peaks are kept uniformly high (around 100% modulation) but are not allowed to overmodulate in excess of 100% (small peaks exceeding 100% are caused by the inertia of the recording pen). As can be seen, no control is exerted on the average level.

Fig. 9 illustrates the positive-peak-controlling action of a limiter followed by a clipper. The input to the limiter-clipper combination has undergone the standard 75 μ s pre-emphasis. No peaks, however, exceed the 100% modulation level to cause FM overmodulation.

Fig. 10 shows a complete automated audio processing system. The system consists of an AGC unit followed by a limiter unit and a clipper unit. (Pre-emphasis occurs between limiter and clipper). This type of complete automatic control is typified by consistently high peak and average levels without overmodulation.

REFERENCES

1. D. C. Connor, "Automatic Audio Level Control," Preprint No. 443, 31st Audio Engineering Society Convention (Oct., 1966).
2. Engineering Department, National Association of Broadcasters, "FM and TV Aural Modulation Measurements," *Engineer's Corner* (May, 1966).
3. H. F. Olson, *Acoustical Engineering*, D. Van Nostrand Company, Inc., Princeton, N.J. (1957).
4. E. Torick and R. Allen, "Amplitude Limiting in Systems with Frequency Dependent Overload Characteristics," Preprint No. 497, 31st Audio Engineering Society Convention (Oct., 1966).

Fig. 9—Positive peak controlling action of a limiter followed by a clipper.

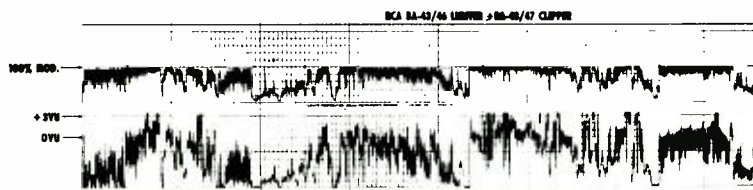
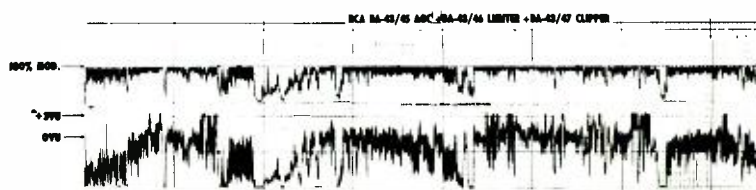

Fig. 10—Result of a completely automated audio processing system.



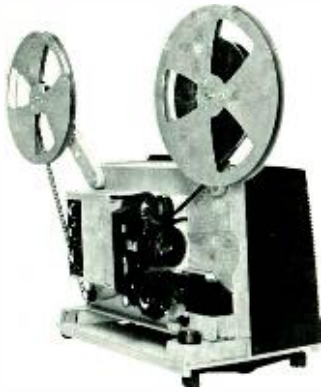

Fig. 1—The RCA-1600 projector.

THE RCA-1600: AN IMPROVED 16-MM SOUND MOTION PICTURE PROJECTOR



Fig. 2—Front view of the projector showing film gate and projection lamp.

The RCA-1600 motion-picture projector combines the best features of the RCA-400 projector with the many design improvements that resulted from the advances in technology since the introduction of the RCA-400. This paper introduces the design rationale for the RCA-1600 projector and describes its functions and features with particular emphasis on the new design improvements that provide ease of operation, more light output, higher reliability, and improved film life.

L. J. ANDERSON and R. D. SHORT, Ldr.

*Audio Visual Products Engineering,
Broadcast and Communications Products Division,
Meadow Lands, Pa.*

SINCE the introduction of the RCA-400 projector some twenty years ago, changes have taken place in the application of 16-mm motion-picture projectors in the educational field. For example, projectors are now used in semi-darkened classrooms and short film segments are used extensively. To meet these new requirements, the projectors must project a brighter picture and must be extremely easy to setup and operate.

A complete review of the new requirements, based on the existing RCA-400 projector, led to the following design goals:

- Increased light output,
- Table-top operation,
- Simplified operation,
- Reversible operation,
- Lighter weight, and
- Long service-free life.

In meeting these goals the desirable features of the RCA-400 were retained. Principally, these are a simple threading path, a swing-out lens gate, spring loaded sprocket shoes, and a minimum number of contacts with the film throughout its traverse through the projector. These features make for simple operating, ease of cleaning, and long film life.

Final manuscript received October 18, 1967.

OPERATING MECHANISM

Before considering some of the unique features contained in the RCA-1600 projector (Fig. 1) a brief description of the mechanism may be helpful.

The film path through the projector is as follows: from the supply reel at the front of the projector, through the upper sprocket and shoe, through the film gate, over a guide roller, under a pressure roller, around the sound drum, over a damper roller, through the lower sprocket, and back to the take-up reel. Film loops are formed above and below the film gate.

The drive for this mechanism is supplied by a 120-volt 60-cycle motor with a capacitor start and associated relay. Such a motor produces a high starting torque for its size and weight and allows the use of a smaller motor than the one used in the RCA-400 projector. The motor speed is approximately 3500 r/min.

A single rotary switch controls the amplifier, projector motor, and projection lamp functions. These functions are identical for forward and reverse, except that in reverse the amplifier is not turned on. The direction of the film motion through the projector is changed by a control switch that reverses the direction of the drive motor.

The blower rotor, in combination with a suitable scroll, cools the lamp. The rotor is mounted on the end of the motor shaft; there is no blower belt to break and cause lamp failure. Since the blower must provide an equal air flow regardless of the direction of rotation, the blades are radial. The dynamically balanced molded rotor operates quietly.

A stepped pulley is mounted on the motor shaft between the motor and blower rotor. A complementary stepped pulley is on the main shaft of the projector. The drive is provided by a flat belt between the two pulleys. A shifter operated from the front of the projector allows either ratio to be used. The lower step-down ratio drives the main shaft at 1440 r/min providing a projection rate of 24 frames/sec for sound pictures. The higher step-down ratio provides a projection rate of 18 frames/sec for silent films.

The shutter and two cams which provide the compound motion required to make the claw move the film are mounted on the main shaft pulley. The part on which the claw is mounted is pivoted at the rear. The up-and-down motion is obtained by parallel rails resting on opposite sides of a constant diameter cam. The in-out motion is provided by a self-

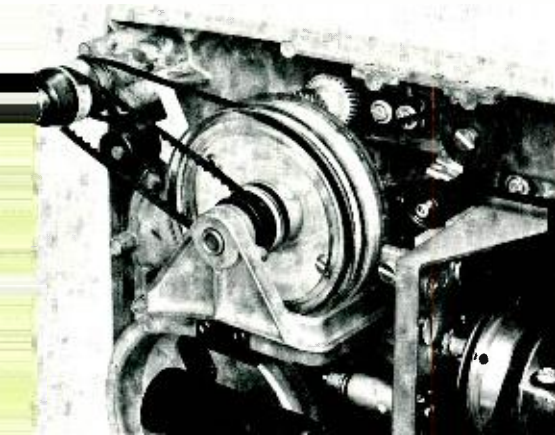

Fig. 3—Rear view of the projector showing the fluid clutch.

lubricating button riding on a disc-type cam.

The opposite end of the main shaft terminates in a worm gear which (through a series of gears, clutches, and timing belts) drives the sprockets at the proper speed and provides for take up of film on either the forward or rear reel depending upon the direction the projector is run. The reel spindles are driven by timing belts contained within the reel arms. The arms, of course, fold down and are locked in the extended or retracted positions by a button conveniently located on the reel arm.

The lens gate is a swing-out type for easy threading and cleaning (Fig. 2). Focusing is accomplished by a rack and pinion arrangement.

The tilt mechanism is contained entirely within the projector; there are no protruding knobs. It is a worm-gear-and-rack type providing fast, easy operation. Both front and rear feet of the projector are rubber to isolate the projector from the surface on which it rests. This prevents the excitation of large surfaces and the consequent radiation of noise.

The feet are placed as far apart as the projector width will allow to give the projector the best possible lateral stability.

SOUND SYSTEM

In the optics of the sound system, a reduction of the exciter lamp filament is focused on the sound track of the film. The modulated light on the far side of the sound track falls on a silicon solar cell. The solar cell was chosen as the light sensitive device because of its stability and simplicity compared to a conventional photocell. Since it is a relatively low impedance device, it requires little shielding against stray electrical signals. Also it requires no polarizing voltage and thereby simplifies the ampli-

fier construction. Response characteristics are excellent, signal-to-noise ratio good, and distortion very low when properly loaded.

The mechanical portion of the sound system consists of a sound drum whose shaft is carried on two ball bearings. Coupled to the shaft is a flywheel of considerable rotational inertia. The compliance of the film loops formed before and after the sound drum and the rotational inertia of the flywheel and sound drum constitute a filter system assuring extremely small speed variations in the film at the sound take-off point. This means reproduction of sound without noticeable "wow" and "flutter."

Variations in speed that might be transmitted to the sound drum from the lower sprocket via the film are further attenuated by a silicone-damped roller placed between the two. This arrangement contributes considerably to rapid stabilization of the film motion at the sound drum when the projector is started.

AMPLIFIER AND SPEAKER

The all solid-state amplifier is supplied with power from the line through a transformer, eliminating shock hazard.

The amplifier is mounted on the interior of the rear cover of the projector, and its output is connected to a loudspeaker at the forward end of the case. The volume and tone controls are mounted immediately above the main function switch on the front of the projector. The tone control provides both boost and cut for the high frequency response. Jacks are provided for a microphone and an

external loudspeaker. The amplifier also provides a well-filtered regulated voltage to the exciter lamp.

FLUID CLUTCH

Ideally, the tension on the film as it is being wound on the film reel during take-up should be constant. That is, there should be no difference between that experienced at the center of a 2000-ft reel and the full reel. In the past, a clutch with an engaging force proportional to the weight of the film and reel was used in the take-up drive mechanism. These systems left much to be desired because the actual tension or torque supplied was subject to wide variations depending on the condition of the clutching surfaces, lubrication, and wear. In the RCA-1600 projector, a fluid-type clutch was inserted into the take-up system (Fig. 3). In such a clutch, the torque provided is roughly proportional to the slip. As the film diameter on the reel increases, the rotational speed of the reel decreases since the film is being fed to the reel at a constant rate. This means that the slip in the fluid clutch has increased with a resulting increase in torque and the tension in the film remains reasonably constant. The clutch itself is a relatively simple device consisting essentially of three molded parts, two of which form the housing. The third is coupled to the housing portion by a silicone fluid. Vanes are provided on one half of the housing and on one face of the inner member to secure the desired fluid-flow action. In the projector, the housing portion is driven by the mechanism, and

ROBERT SHORT received the BSME in 1952 from the University of Pittsburgh. He joined the Radio and Phonograph section of the Home Instrument Engineering Department of RCA and was responsible for the design of many radios and phonographs and the initial development of printed circuits and printed circuit standards for use in radios. From 1959 to 1963, he worked on the engineering model of BMEWS and then transferred to the Meadow Lands plant of the Broadcast & Communications Products Division. Since 1963, he has worked on several mobile transmitters and played an important part in a general cost reduction of the mobile line of equipment. In 1966, he became leader in the audio visual products engineering section and has been responsible for the RCA-1600 projector improvement program and a major cost reduction program on this projector.



L. J. ANDERSON received the BS degree in electrical engineering from Illinois Institute of Technology in 1928. Starting with the GE Company and continuing with RCA in Camden he was, from 1928 to 1941, engaged in the development and design of microphones used for broadcasting and sound recording. In 1941 he was transferred to the RCA plant in Indianapolis and continued to work on the development of acoustical items, both government and commercial. In 1946 he returned to Camden and was responsible for the development and design of microphones, loudspeakers, and associated items used in broadcast and sound systems. In 1960 he was transferred to the RCA plant in Meadow Lands where he has since been engaged in the product design of sound equipment, teaching equipment and the RCA-1600 16 mm projector.



the driven portion is coupled to the reel arms through timing belts.

The fluid clutch allows one more unique function: it is mounted so that it can slide on the upper sprocket shaft which serves only as a carrier and it is driven by a helical gear. When the projector is reversed, the axial force supplied by the helical drive gear is reversed causing the clutch assembly to assume either an "in" or an "out" position on the shaft. When "out," it is coupled to the front reel arm and performs the film take-up function for reverse operation. When "in," it is coupled to the rear reel arm and performs a similar function for forward operation of the projector. Thus, change in reel function is obtained automatically when the drive motor is reversed.

SAFE THREADER

No matter how simple the threading of a projector may be, a certain amount of dexterity, judgment, and experience are required to do it quickly and correctly. Some type of automatic threading device is, therefore, a necessity. To ease the job of hand threading and to allow the removal of a partially run film without difficulty, the *safe threading* device was developed for the RCA-1600 projector. Basically, it consists of a molded plastic labyrinth to guide the film and to establish the correct size loop in the various portions of the film path (Fig. 4). The guide is made retractable by allowing two shafts which form a part of it to slide in two bearings in the main frame of the projector. There are two positions of the safe threader: in the thread position, it is pushed in against the projector main frame; in the retracted position, it is completely out of the film path.

In the thread position, the upper end of the film pressure shoe in the film gate is partially opened and the pressure roller on the sound drum is lifted. The operation is simple:

- 1) The end of the film is trimmed in the film cutter located just below the exciter lamp cover.
- 2) The projector is started forward.
- 3) The film is inserted between the upper sprocket and shoe (the lift-to-rewind lever serves as a guide).

- 4) The upper sprocket drives the film through the labyrinth into the partially opened gate where it is picked up by the claw teeth and driven around the sound drum, guided by the exciter lamp cover, to the lower sprocket where, in turn, it is driven to where it can be picked up and manually attached to the rear or take-up reel.
- 5) The safe threader is retracted so that it is completely out of the film path, and the projector is completely threaded and ready to run.

Should it be desirable to thread the projector manually or to remove a partially run film, the safe threader may be removed completely from the projector. Loss of the safe-threader accessory is prevented by a small chain attaching it to the projector.

LIGHT OUTPUT

The light output from the projector is dependent on:

- 1) The brightness of the light source;
- 2) The efficiency of the light condenser lens system;
- 3) The percentage of the time that the frame being projected is exposed to the light; and
- 4) The transmission number of the projection lens.

The projector is designed to handle a 1200-watt lamp, thus assuring an adequate source. A condenser-lens system was designed to take full advantage of this source and at the same time allow projection lenses of focal lengths from 1.5 inches to 4 inches (with *f* numbers in the range of 1.4 to 1.6) to operate at their full efficiency.

The light output was further increased by shortening the pull-down time of the film. This allows the projected frame to be exposed to the light a greater length of time. The cam angle is 50° allowing an exposure of 210° for a three-blade shutter, or 260° for a two blade shutter. This compares with 150° and 220° for the RCA-400 projector.

A further increase in light output was obtained by designing the projector to accept the large barrel (2-inch diameter) lens. With this diameter lens, the 2-inch focal-length lens may be designed for a value of *f*/1.4 rather than *f*/1.6. Further, the projector will accept any projection lens, smooth barrel or other-

wise, of this diameter. An adapter is available to allow the use of older small-barrel lenses.

MATERIALS

Many more materials are available now than when the RCA-400 projector was designed, and a careful choice has resulted in increased potential life as well as continued good appearance for the RCA-1600 projector.

Wherever strength was a factor in the mechanism, aluminum was chosen as a die casting material, and where weight was a prime consideration, magnesium was selected. Painted surfaces on the covers and handles were avoided by making these parts of Cycolac (rubber modified styrene material) which, in addition to being extremely resistant to fracture, has the same color throughout. Materials incorporating self-lubricating properties were used throughout for gears and for bearings where load conditions would permit. At heavily loaded points (such as the reel-arm bearings, the main-shaft bearings, and the one idler gear), permanently lubricated ball bearings were selected. Less heavily loaded bearings and those at points having lower shaft velocities are sintered bronzes impregnated with oil. Cams and cam-follower materials were also selected for long life. Stellite has been retained as a claw material to move the film since no other material has exhibited comparable life characteristics. A solid state amplifier replaces the tube-type amplifier of the RCA-400 projector.

ACCESSORIES AND CONVENIENCE ITEMS

No projector would be complete without accessory items to fit the projector to special applications. First, of course, is the special reel, which is not really an accessory since it is supplied with every projector. In addition to its prime function as a take-up reel, it is designed to hold up to 17 ft of projector cable and still fit easily into the slot in the base of the projector. When not used for this purpose it serves as a take-up reel. Among other accessories are projection lenses ranging from 1.5 inches to 4 inches, a "zoom" lens, an anamorphic lens, an air filter, auxiliary speakers, protective covers, an adjustable iris that allows the light output of two projectors to be matched, and rear-screen projection equipment.

ACKNOWLEDGEMENTS

The authors acknowledge the contributions of Mr. J. L. Young and Mr. R. A. Lichalk for much of the initial development and design. Credit for the functional design goes to Mr. S. W. Pike.

Fig. 4—Safe threader.

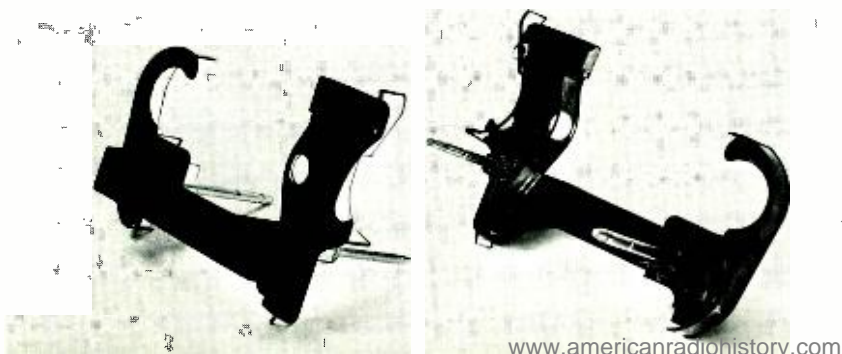

PLANNING FOR COMMUNICATIONS SATELLITE RESEARCH AND DEVELOPMENT

The use of satellites for communication as a rapidly evolving technique is discussed in terms of past, present, and future concepts and the application of planned facilities. Broadcast satellites and distribution satellites are introduced, with consideration of economic and technical factors and earth-terminal facilities.

Dr. S. W. SPAULDING, Mgr.

Communications Satellite Missions

Astro-Electronics Division, Princeton, New Jersey

SATELLITE COMMUNICATIONS is one of the most rapidly evolving technologies in the space field. This rapid evolution takes advantage of many techniques developed for other missions as well as research and development intended specifically for communication satellites. The technology base already developed for space use will permit significant increases in communications capability, but the day is not far away when further growth will depend on an investment in research and development yet to be committed.

The first designs were modest applications of already proven technology except perhaps for the traveling-wave-tube application, although even that had some flight history. Both TELSTAR and RELAY were the simplest types of satellite and even their reliability in orbit was a matter of considerable speculation in 1961. In the six years since the beginning of the RELAY project, the concern over lifetime has diminished and has been replaced by the spectre of technological obsoles-

Final manuscript received July 11, 1967.

cence. It has now been well established by the performance of TIROS, RELAY, SYNCOM, and EARLY BIRD that lifetime is not the problem. The problem of obsolescence is illustrated by the dilemma facing the COMSAT Corporation on the use of its global satellites. The particular technology causing the difficulty is the rapid emergence of high-gain satellite antennas as feasible. In July 1966, the FCC approved the contract that COMSAT requested to begin development of the "global system." The approval came after months of delay and discussion involving the likely obsolescence of the "global system" (INTELSAT III) in view of the availability of the INTELSAT II and the proposed INTELSAT IV or the multi-purpose satellite. The key issues were whether 1) to add to the INTELSAT II capability by including an electrically despun antenna and leapfrog to the multi-purpose satellite or 2) to restrict the INTELSAT II development and delay the multi-purpose design until 1972 to insure an operational INTELSAT III. The key feature of the multi-purpose design

was the fully stabilized, high-gain antenna with multiple beams. Many factors were considered, including the desire to fulfill the letter of the interim agreements and have a global system in place by late 1967. While that date has since slipped to the latter part of 1968, it was felt at the time that the multi-purpose technology (high-gain antenna) was not yet at hand. Less than one year later, COMSAT announced plans to reverse its original selection of an electrically despun antenna and use a mechanically despun antenna for INTELSAT III. While this approach could lend itself readily to a high-gain antenna on the satellite, with subsequent savings in earth terminals, there is no indication that INTELSAT III will carry such an antenna. This particular technological advance is being reserved for INTELSAT IV, the multi-purpose satellite. In September 1967, the COMSAT Corporation requested INTELSAT to proceed with INTELSAT IV for launching in late 1969.

INTELSAT presently has two satellites over the Atlantic and two over the



S. W. SPAULDING received the BS and MS degrees from Rensselaer Polytechnic Institute and PhD degree from Temple University. Dr. Spaulding joined the Advanced Development Section of RCA in 1950 and worked in assignments related to digital computer applications and military electronics. In 1958, he became Manager of the Systems Analysis group where he was responsible for system studies and proposals of manned and unmanned satellites and probes. In 1961 Dr. Spaulding was assigned as Project Manager for the Ranger-6

Project. In 1963, he joined COMSAT in Washington, D.C. as Manager of Systems Analysis. His responsibility included defining the program requirements for the Early Bird satellite, the 1964 Olympic demonstration with Syncom III, the INTELSAT programs, and the US domestic system. In June 1966, Dr. Spaulding rejoined RCA in the Astro-Electronics Division where he is presently the Manager, Communications Satellite Missions. He holds five patents pertaining to computer and radar circuits.

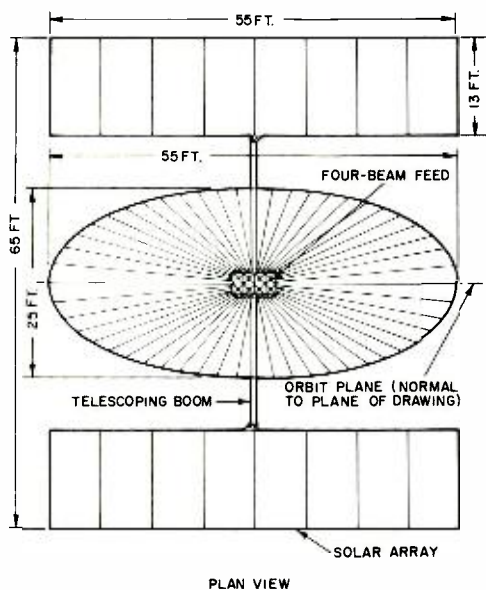

Fig. 1a—TV Broadcast satellite configuration, plan view.

Pacific, each with a capacity of 240 standard telephone circuits. One of these, the EARLY BIRD, is more than two-and-a-half years old and still going strong. In the Atlantic area, the FCC has approved the laying of a new transistorized cable to Puerto Rico, which will considerably ease the load for the satellites. AT&T has requested permission to install a similar cable (TAT-5) to Portugal. These factors all tend to increase the period of usefulness of today's satellites and advance the arrival of new technology into service. COMSAT has requested that the FCC grant permission for deploying a pilot domestic system which, if granted, would advance the development of the multi-purpose satellite. Thus, the possibility of having this satellite available to take over from the present INTEL SAT II is increasing. The applicability of the particular technology chosen for INTEL SAT III hangs in the balance.

This only highlights the problem of technological obsolescence wherein a given choice may be made obsolete by later developments before a satellite has worn out, has paid for itself in service rendered, or even before it has been launched. The capability of research and development progress and its impact on cost are dramatized by the relative cost of the COMSAT global satellites and the INSCP-A satellites procured one year later. COMSAT will pay upwards of 40 million dollars for six INTEL SAT III satellites, while the military satellites for INSCP-A will provide almost the same capability and a lifetime at a reported

cost of approximately 7 million dollars for two flight-model satellites.

The only protection against these problems is a knowledgeable research and development effort, which will permit the satellite planner to select the slice of technology best suited and most adaptable to the time period of its intended use. In today's environment, the forthcoming domestic use of satellites, the plans for direct radio and television broadcasting, space-to-space data links, and air traffic control and navigational uses all are creating special development problems. Some of these problems are discussed in the following sections.

BROADCAST SATELLITES

The next generation of communication satellites will be characterized by the need to work with small terminals. These will be small either because there are many of them and the economics dictate a small terminal or because the terminal is on an aircraft, a satellite, or elsewhere where physical constraints are imposed. The satellites will, therefore, be larger and more powerful to enhance the total link capacity; larger power supplies and larger antennas will be required. The broadcast satellites will be the prime example of this next generation. To work directly into home receivers, with a minimum of modification expense to the average user, the satellite will have to develop kilowatts of radiated power and have a large antenna. The UHF television band is the best suited, because of the need for a clear channel at a frequency for which there are already millions of sets available.

At this frequency, one can choose between tubes and solid-state devices for power amplifiers. Since the latter devices develop relatively low power, hundreds (or even thousands) of them must be coupled together to develop the necessary power. Further development is desirable before making the final choice, but the merits of solid state are becoming clear.

The problems of adapting high power tubes to the space environment, the solving of the cooling problem, and the proving out of their life are the key developments. Increases in efficiency are also highly desirable. The situation on tube life is not like the traveling-wave tube (TWT) in the earlier satellites. The TWT had been designed for long life out of necessity, because of the sheer numbers of remote and unattended repeaters. The high-powered broadcast tubes have not had a similar factor in their development. While the klystron and TWT offer advantages for FM signals, the triode has advantages for AM signals required for compatibility with existing UHF sets. In

any case, a suitable tube has yet to be developed although such a development is generally accepted as feasible with only the time, cost, and the optimum configuration being a subject of discussion.

There are two approaches to the use of solid-state devices. The first is one of paralleling the individual transistors in pairs, using many lightweight combiners. The development of such a combiner and the cooling of the collection of power amplifiers are practical developments required. An alternate is to let each power amplifier be tied to a radiating element in a retro-directive phased array antenna. This distributes the heat generators over the large area of the antenna and avoids cooling problems. The energy combines in the interference pattern of the antenna, obviating the need for combiners. The use of a retro-directed phased array eliminates the need for phase shifters and a computer to control them. The phased array also permits a flexible, multiple-beam arrangement.

The power supply problem has received considerable study in NASA-sponsored contracts. A fifty-kilowatt supply is the largest given serious consideration. The problems are basically weight and packaging into a shroud. Even under the best of estimates of cell performance, the arrays will require several thousands of square feet and will need to be oriented toward the sun. Since the antenna must look toward the earth, there is a daily rotation between these major parts of the satellite; kilowatts of power must be transferred across a rotating joint. The thousands of square feet of array must be folded into a package fitting inside the launch-vehicle shroud. These represent some of the major challenges of engineering development in the area of broadcast satellites.

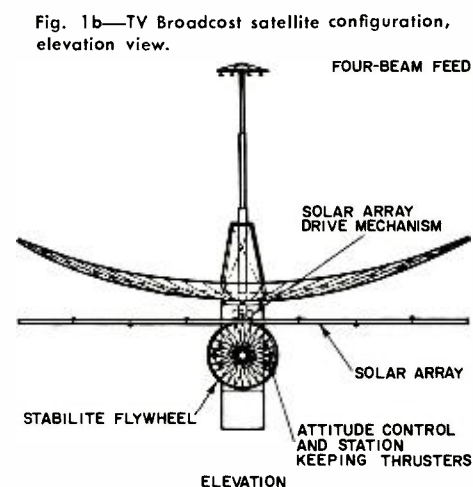

Fig. 1b—TV Broadcast satellite configuration, elevation view.

Another example of a satellite requiring technology similar to that of the broadcast satellite is the DATA RELAY satellite. Such a satellite at synchronous altitude would relay data between various small terminals and a ground control point. The small terminals could be on low altitude satellites, other synchronous satellites, or remote terminals such as balloons or buoys. The principle features are a large antenna aperture to ease the antenna requirements on participating terminals and powers in the kilowatt range to support data transmission back to these terminals for control and other purposes.

These requirements are illustrated by the TV broadcast satellite configuration shown in Fig. 1; the satellite characteristics are listed in Table I. The high-gain antenna requires large antenna sizes and an accurate stabilization system at compatible UHF frequencies.

DISTRIBUTION SATELLITES

In August 1965, the American Broadcasting Company filed a petition with the FCC requesting permission to launch and operate its own communication satellites for the purpose of distributing TV programs to local network stations. This was introduced the issue of the use of satellites for domestic communications. This has been called the "distribution" satellite because it would "distribute" programs to the local station rather than broadcast directly to the home. There have since been several proposals for satellite designs for this purpose, all of which make use of multiple-beam, high-gain antennas as the means of achieving the flux densities required to make the cost of the earth terminals economically feasible. This principle of operation is by no means unique to the domestic problem and could be readily extended to the

global system for international traffic with similar savings in earth terminals.

TABLE I—Direct TV Broadcast Satellite Characteristics

Characteristic	Quality
Orbit	Geostationary
Booster	TITAN III-F
Satellite weight	3300 pounds
Power Supply	Oriented solar array 1400 sq. ft.: 8 kW
Stabilization	3-axis STABILITE
Transmitted power	4 beams @ 0.6 kW
Antenna	25 x 55 ft parabolic; gain 36.5 dB
Frequency	Channel 68 and 69
Video ERP per beam	61.3 dBW

The development of multiple-beam antenna systems that can be flexibly programmed is required for this service. A phased array antenna at the frequencies presently in use (4 to 6 GHz) would be one solution. In addition to these, research and development should be initiated now on techniques at higher frequencies such as 18 and 30 GHz.

The post-1975 projections of traffic indicate a need for more of the spectrum that is available in the authorized bands at 4 and 6 GHz. While satellites were authorized to use this band, co-existing peacefully with terrestrial systems, it is incumbent upon the satellite designers to recognize the limitations of this band and plan ahead.¹ Thus, development in the region of spectrum from 10 to 100 GHz should begin now. In the meantime, parallel efforts should begin to make maximum use of the 4 to 6 GHz band by antenna-polarization and gain-isolation techniques that will permit re-use of this band in various satellites.

The benefits of antenna gain are illustrated in Fig. 2. In this summary, the total weight available for antenna, power supply, and electronics is taken as fixed, with other appropriations left for non-communications functions. The antenna size is varied and its weight subtracted

from the allowed weight. The remaining weight is translated into power, and the total ERP is found. The significance of antenna gain is clear. For the 4-GHz case illustrated, an antenna diameter of ten to fifteen feet results in the greatest ERP. The rapid decrease at twenty feet results from the fact that the antenna uses most of the weight, leaving very little for power supply.

The use of antenna gain and polarization to permit the double use of the assigned spectrum is illustrated in Fig. 3. The isolation between beams would permit the re-use of the frequencies without interference between beams. The concentration of signals into regions removes the signals from other areas and relieves the build-up of signals that could interfere with established terrestrial facilities. Further development of the erectable antennas, the feed systems, and other auxiliary techniques is required to ensure that this important concept is available for the domestic system. Other approaches using a single-beam coverage result in less complicated routing procedures, but are wasteful of spectrum and are more likely to add to the general level of interference power density.

A corollary to this relates to the proliferation of large, sensitive earth terminals in the United States. As more of these terminals are activated, it becomes difficult to avoid interfering with them because of their extreme sensitivity and such phenomena as scatter from the troposphere, rain, and aircraft.² Thus, the emplacement of a domestic system could become restricted by the presence of international satellites requiring these sensitive terminals, because the satellites would not be programmed to take advantage of satellite antenna gain and isolation.

CONCLUDING REMARKS

The forthcoming 1969 renegotiation of the INTEL SAT agreements will require policy decisions in each country about the rights it may reserve to operate its own domestic system separately from an internationally owned system. Some of the key development questions needed to permit the formulation of a final policy are not yet answered. Pending such technological developments, a prudent policy must reserve the spectrum for domestic use and not proliferate earth station and satellite concepts likely to restrict or even prohibit the development of a national system on any economical basis.

REFERENCES

- 1) Docket No. 16495 "An Integrated Space/Earth Communication System," AT&T.
- 2) FCC Measurement Program on 6 to 4 GHz Scatter (POPSI-Precipitation Off Path Scatter Investigation).

Fig. 2—Satellite optimization.

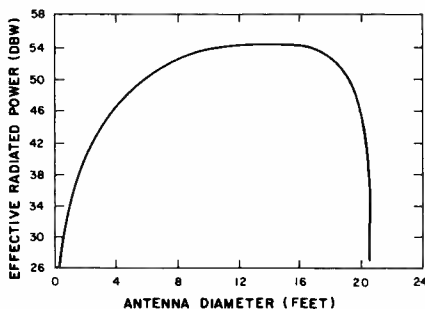
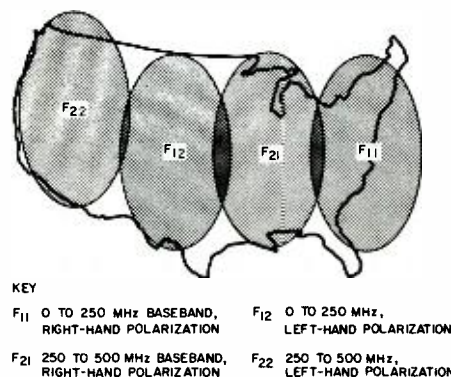

Fig. 3—Beam coverage for spectrum re-use.



A NOVEL INTERCHANGEABLE MAGAZINE TV SLIDE PROJECTOR

The RCA TP-77 TV slide projector (Fig. 1) simplifies the handling of 2 x 2 slides for news and spot commercials in TV broadcasting. A single magazine replaces the previous method requiring alternate loading into two drums. The TP-77 permits advanced loading (programming), and repeat programming when operated with RCA's new annular slide storage device having 120 slide compartments. Design provides accessibility to all slides in the system including those in the slide gates. The optical system produces a previewing image on a translucent screen so that order and orientation of program material can be checked in advance. This paper discusses the mechanical and optical design features which have resulted in such increased flexibility.

W. F. FISHER and B. F. FLODEN

TV Projector Engineering

Broadcast and Communications Products Div., Camden, N.J.

SLIDE TRANSPARENCIES constitute a very important segment of television broadcasting. TV "spot" commercials, news, and public service information all rely heavily on the slide projector and 2 x 2 slides. It is current practice in a television station to maintain slide libraries from which particular groups of slides scheduled for broadcasting are extracted and transported to the film room for programming use.

PRESENT PROJECTOR LIMITATIONS

Most present-day television slide projectors are designed so that slides must be alternately loaded into two drums or magazines located on either side of an optical projection system. Caution must be exercised to insure that the slides are

Final manuscript received October 31, 1967.

loaded in proper sequence and properly oriented.

A typical film-camera chain (Fig. 2) consists of a film camera, an optical multiplexer, two motion-picture projectors and a slide projector. The multiplexer with its moving mirror array selects and directs light from the various projectors to form a real image at the field lens of the camera. The light is redirected by the field lens to enter the objective lens of the camera. The projection lenses, camera lenses, and field lens are interdependent and must be chosen to present images of the proper magnification at both the field lens and the camera pick-up tube without vignetting.

NEW RCA TP-77 SIMPLIFIED DESIGN

The new RCA TP-77 Television Slide

Projector (Fig. 3) provides superior technical performance and embodies a novel design format which greatly reduces problems in slide handling, editing, and programming.

The TP-77 uses but one magazine. It is significant that the magazine is not an integral part of the projector, and that any number of the same type magazines may be used. Program segments may be loaded into separate magazines well in advance of air time. The linear magazine used with the TP-77 is the type readily available in photographic stores at a moderate price and used with relatively inexpensive home-type slide projectors. Thus, slide sequencing and orientation may be checked in the editing room inexpensively.

W. J. FISHER received the BSc degree in mechanical engineering from Drexel Evening College in 1953. Mr. Fisher joined RCA in 1950 as a member

of broadcast studio engineering where he worked on terminal equipment and TV cameras. For the past twelve years, Mr. Fisher has worked on the de-

sign and development of film projection equipment. He is the author of several technical papers and is a member of the SMPTE.

W. J. Fisher



B. F. Floden



B. F. FLODEN received degrees in aeronautical and mechanical engineering in 1939 from Tekniska Institutet, Stockholm, Sweden. He held positions in aeronautical engineering with Götaverken's Flygautdelning and with the Swedish Air Force. From 1945 until his emigration in the fall of 1959 he was active in mechanical design engineering and was the manager of an aircraft maintenance shop. He made an invention and formed a company for its development and marketing during a seven year period. He then spent four years in industrial engineering. Mr. Floden joined the projector group of RCA Broadcast and Communications Products Division in February 1960 where some of his work in the field of television film projectors has resulted in six patents that are utilized in the TP-65 16mm TV projector.

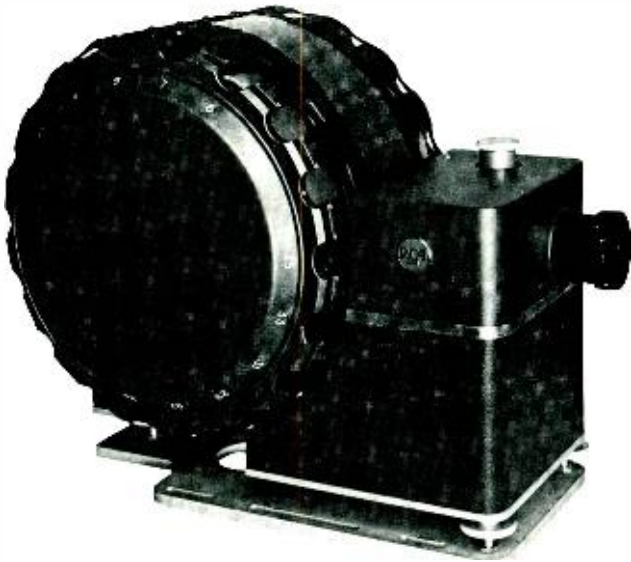

Fig. 1—Type TP-77 slide projector equipment MI-40011-B.

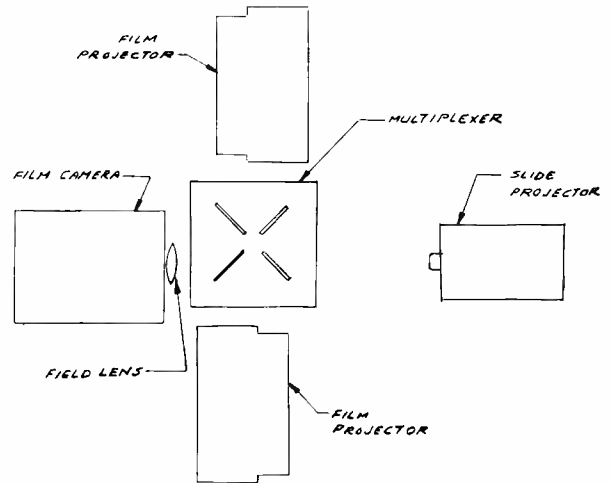

Fig. 2—Typical film island.

One magazine may be replaced quickly with another so, in effect, the projector has an infinite capacity; but, this involves a major disadvantage of requiring attended operation. Therefore, when more than the thirty-six or forty slides provided by a linear magazine are required, the RCA annular type of magazine should be used; designed to operate with the TP-77, this new RCA slide-storage device contains 120 slide compartments. Slides may be loaded in all compartments or may be sectionalized to fit requirements for repeat programming.

The original design of the round magazine was undertaken primarily to conform to USAS standards regarding slides for television film-camera chains; the maximum thickness of slides specified by

the standard is one-eighth inch. Commercially available, high-capacity magazines, capable of being adapted into the projector design, would not accommodate slides having maximum thickness.

In the operation of the TP-77 Slide Projector, slides are fed from the magazine and are transported to one or the other of two vertically oriented film planes for projection onto the field lens of a monochrome or color-film camera (Fig. 3). After a slide has been shown, it is returned to the slide compartment in the magazine from which it was removed.

TP-77 MECHANICAL DESIGN FEATURES

Optical System

The dual-channel optical system (Fig. 4)

has for its light source a horizontally burning 500-watt halogen-cycle quartz lamp. Light is collected from both sides of the lamp and directed by a mirror into the upper and lower gates. A mirror-multiplexing system located between the film gates and the projection lens permits switching between gates. Switching is achieved by a mirror which moves alternately in and out of the light path. When the mirror is in the optical system, the light from the bottom channel is directed into the projection lens and the light from the upper channel is blocked. The light from the upper channel is projected when the moving mirror is retracted. The need exists for a dual-channel optical arrangement and multiplexing system that will present continu-



Fig. 3—Type TP-77 slide projector with rotary slide.

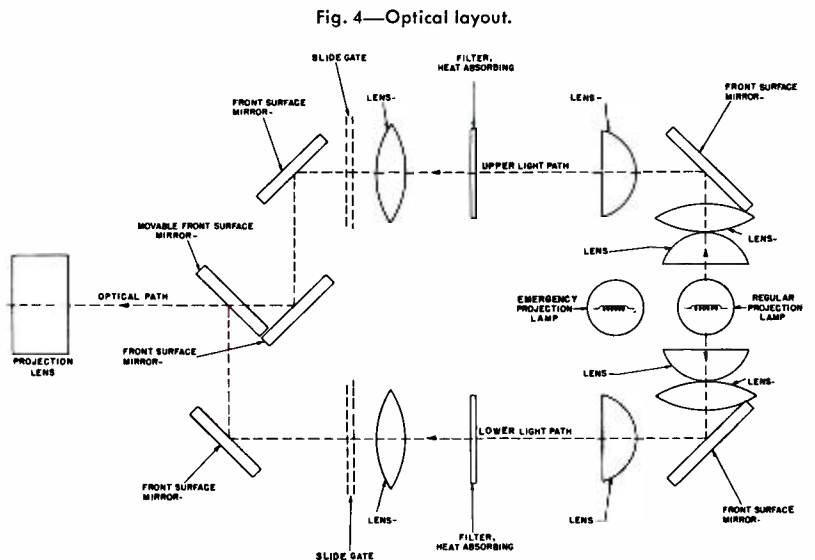

Fig. 4—Optical layout.

ous slide program without any perceptible transition from slide to slide. In projectors for home viewing or lecture purposes, the screen usually goes dark while the next slide is being inserted in the film gate. This type of operation is unacceptable for television.

Thus the TP-77, with dual gates has two slides always ready for projection. An imperceptible transition from one slide to the other is effected by the rapid movement of the multiplexing mirror. While the slide selected by the moving mirror is "on-the-air," the slide previously shown is returned to the magazine; also, the next slide is positioned in the alternate slide gate ready for programming. The unique mechanism that accomplishes the slide change is described below.

Moving Gates

The dual-light channels supply illumination to two slide-projection stations or gates centered one above the other, 6 inches apart. The slide magazine is supported on an intermediate level but offset approximately $2\frac{3}{4}$ inches from the vertical plane of the optical center lines.

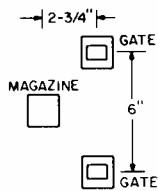

Transporting slides between the magazine and the two projection stations becomes simple and reliable by making the slide gates movable. For a slide change, the gate is moved vertically in the slide plane to a loading station where the slide is level with the magazine, and only a short, horizontal transfer between gate and magazine is required.

Gate Mechanism

The gate employs locating surfaces for the slide and spring-loaded shoes that guide the slide against these surfaces. The shoes allow for normal variations in slide dimensions.



Each gate is carried by two arms that form a 4-bar parallelogram linkage with

the gate and two fixed points on the mechanism frame. The arms are actuated by a cam and a spring that are common to the two sets of gate linkage.

Slide Pusher

The transfer of slides between the magazine and a gate in the loading station is done by two pushers on a common carrier.



The *in* pusher is a blade that reaches through the compartments of the magazine and pushes the slide close to the proper position in the gate. The *out* pusher takes the slide out of the gate and pushes it completely into the magazine. A secondary function of the *out* pusher is to remove "forgotten" slides in the gates; this is explained further in the discussion of "load and clear cycles."

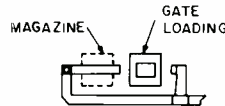

Pusher Mechanism

The carrier of the pushers is supported by two different means. The outer support is a ball-rail arrangement, and the inner support is a straight-line linkage that also serves as an amplifier of the output from the driving cam mechanism.

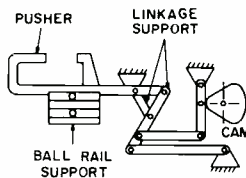

Forces from acceleration and deceleration of pusher parts are opposed by a moving mass attached to the short link of the straight-line linkage to minimize vibration.

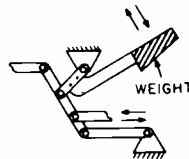

Two cams on a common shaft are employed for the pusher drive. The two cam followers are carried by separate arms on a common shaft; a heavy torsional spring between the two arms compensates for minor cam-form errors

and other tolerances to insure quiet operation.

Magazine Transport Operation

The linear magazine has a toothed rack along its lower outer edge which engages an intermittently moving claw. The tooth spaces line up with the compartments and the pitch of the rack is 0.22 inch.

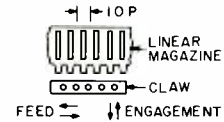

The round magazine has a similar tooth arrangement along its periphery. However, the geometry involved results in a larger pitch, 0.33 inch.



The magazine advances on a *one-step-back/two-step-forward* pattern during each slide-change cycle. The reason for this is basically that two slides are out of the magazine most of the time, and that each one must be returned to the compartment from which it was taken. The following is a description of the sequential events of a slide-change cycle; when the projector is loaded up with slide #1 on-the-air in the top gate, slide #2 in the lower gate ready for projection, and with the *forward-change* button pressed, the following will occur:

- 1) The movable mirror changes position to block the upper gate and put the lower gate (with slide #2) on-the-air.
- 2) The magazine *moves back one step* to line up compartment #1 with pusher and gates.
- 3) The *in* pusher enters compartment #1 and moves to the inner position where the two pushers are straddling the load station.
- 4) The upper gate goes down to the load station.
- 5) The pushers move out to bring slide #1 out of the gate into compartment #1 of the magazine and come to rest straddling the magazine.
- 6) The *magazine advances two steps* to compartment #3.
- 7) The pushers move in again forcing slide #3 out of the magazine and into the gate that has been waiting at the load station.
- 8) The gate moves up to its projection station. As the gate approaches its proper position the slide is nudged into correct lateral position by a guide on its right.

- 9) The pushers move out to straddle the magazine and the mechanism stops with slide #2 being projected and slide #3 ready.

The magazine-engaging claw is designed for a range of travel equal to twice the pitch, and an engagement motion that lifts the claw out of the teeth during one of the two return strokes of each change cycle.

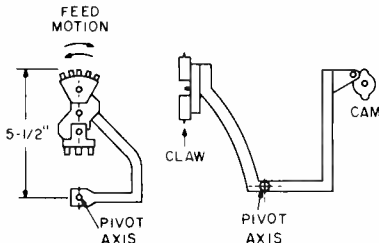

The claw is carried by a rigid arm that has rocking motions on two axes located about 5½ inches below the magazine shelf. The mechanism for the engagement rocking of the claw is basically a lever with one arm extended from the pivot axis to carry a cam follower, and a second arm extended to carry the claw.

The mechanism for the claw-feed rocking is more complicated as selection must be possible between two different cam-throw amplifications to meet the difference in pitch between the linear and the round-magazine types.

The problem is solved by using a two-step mechanical amplifier where the output from the first step is presented about 1¼ inches below the claw level and 3¾ inches behind the plane of the gates, underneath the magazine shelf. This output is essentially a rocking motion of a pin with an amplitude of approximately 93% of the linear magazine pitch. The motion is cam driven with spring return.

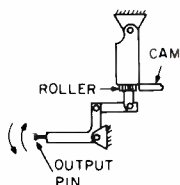

The second-step mechanical amplifier consists of the arm that carries the working claw at the top, and a link that connects this arm with the output pin of the first amplifier. The link is flexible to allow for the type of motion of the output pin, and to allow for the engagement rocking of the claw.

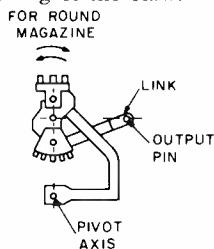

The top of the arm has a claw holder that can be set in two positions 180° apart. In one, the 0.22-inch pitch claw (5 teeth) is up, and in the other, the 0.33-inch pitch claw (3 teeth) is in the active position. The claw holder also carries the connection point for the flexible link, so that when the claw change is made, the link connection point on the arm is changed at the same time. Notice that the link is slanted opposite ways from the intermediate level of the output pin of the first amplifier. The two different link connection points on the claw arm correspond to the two claw strokes, 0.22 inch and 0.33 inch, of the straight and the round magazines respectively.

Cam Shafts and Move Motor

The timing of the events involved in a slide-change cycle as mentioned in the foregoing, is controlled by two cam shafts. An upper shaft carries cams for the motions of gates and the magazine transport, as well as shading flags for light switches that feed position signals to the control circuitry. The lower shaft carries cams for the slide pusher motion.

The upper shaft turns 180° for each slide-change cycle while the lower shaft turns 720°. Looking at the different cams, this means that the gate cam has a single lobe that alternately actuates the upper and the lower gate, while the claw engagement cam, and the magazine transport cam both have double sets of working curves and dwell surfaces.

The two cams of the lower shaft are both employed in the slide-pusher drive. Thus, each has a single lobe and provides positive drive in both directions of the pusher. The two cam shafts are interconnected by a 4:1 timing belt drive.

The mechanism is driven by a gear motor that is connected to the lower cam shaft by a timing belt drive.

The operation of the projector requires that the slide transport mechanism stops at a predetermined point in the change cycle after each slide change. This is achieved by providing an electrical braking system for the drive motor. When the mechanism has moved to a point corresponding to the completion of one change cycle, a signal obtained from the position-sensing light-switch cuts off power to the drive motor; at the same

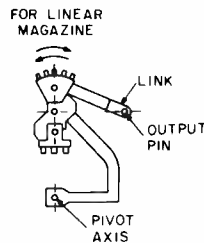

time, this gates the 120-Hz trigger-generator and turns on a triac connected across the motor winding. Thus the triac, having been triggered into conduction, provides a short-circuited path for the collapsing AC field and brakes the motor in less than 8 milliseconds.

Load and Clear Cycles—Slide Rejection

The basic operation of the slide-transport mechanism requires that projection start with the first slide in the magazine and end with the last slide.

This limitation is removed by an arrangement that makes it possible to skip either the first or the second of the two excursions made by the slide pusher during each slide change cycle.

Load Cycle

When the *load* button is pressed the machine runs through two slide-change cycles during which the pusher only makes the second or loading excursion in each cycle. The unload excursion is skipped. This might mean that a *left-over slide* is already in the gate when the load excursion occurs. This leftover slide will simply be pushed straight through the slide holders of the gate into a chute behind the loading station and fall down into the area below the magazine shelf.

Clear Cycle

When the clear button is pressed, the machine runs through two slide-change cycles during which the pusher only makes the first or unloading excursion in each cycle. The load excursion is skipped. If a projectionist should inadvertently activate the clear function when the load function is intended, the pusher will deliver two slides to the load station when no gate is there to accept them. The affected slides are the two just ahead of the first slide intended to be loaded. They will fall down into the area below the magazine shelf.

Load-Clear Mechanism

A solenoid operated hook-clutch arrangement is employed in the pusher mechanism. It is activated to disconnect the pusher from its drive, and to hold the pusher anchored in its outer position.

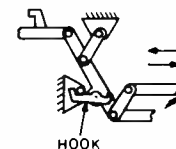

Photocells and flags rotating with the upper cam shaft of the mechanism are employed in the timing of the clutch operation.

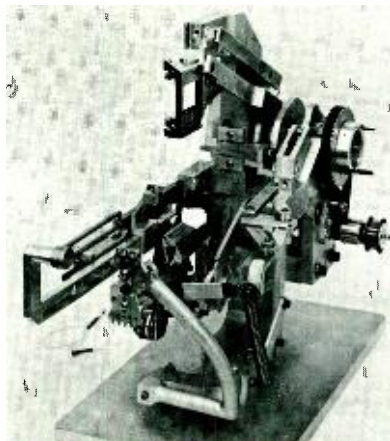
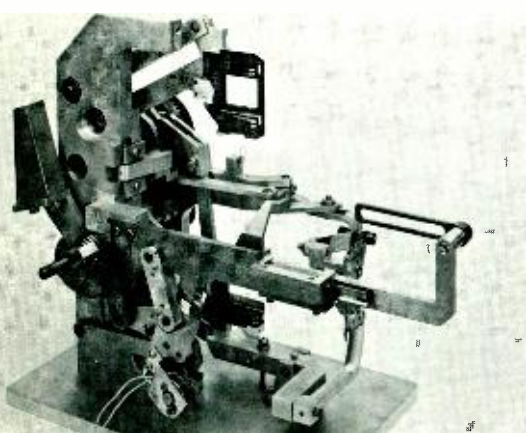

Fig. 5—Mechanism for the TP-77 projector.

CONTROL RELIABILITY

In equipment of this nature where the broadcaster depends upon the presentation of revenue-producing commercial messages, reliability is of paramount importance. A major step toward achieving this end was the decision to eliminate mechanical switching wherever switch actuation was previously done mechanically.

The control circuit selected was divided into two distinct parts—*logic* and *power* switching. The logic circuits are designed using dual in-line integrated circuits to provide the flip-flop memories and the NOR and NAND gates required for signal steering. Synchronous AC power switching is performed by triacs and a 120 Hz trigger generator. Power is applied to the inductive loads at zero axis crossings to minimize inrush currents which may cause transients on the power line.

Mechanism position sensing, which provides properly timed signals for specific modes of operation, is achieved by the use of photo-resistors and long-life lamps. Once properly adjusted, these components which are not subjected to any mechanical strain will stay adjusted.

PROJECTOR CONTROL FUNCTIONS

The TP-77 may be controlled either at the projector or from a remote panel constructed specifically for this purpose. At the projector the following control functions are available:

- 1) *Forward Change*—changes slides sequentially with the mechanism operating in the forward direction.
- 2) *Reverse Change*—changes slides sequentially with the mechanism operating in the reverse direction.
- 3) *Load*—inserts one slide into each of the two slide gates at the beginning of a program.
- 4) *Clear*—returns the slides in both gates to the magazine.
- 5) *Preview*—changes the position of the moving mirror without operating the

changer mechanism. Thus, the next slide to be shown on air may be viewed on a monitor.

- 6) *Lamp on—Lamp off*—operates the projection lamp and supplies tally information to indicate state of the lamp.
- 7) *Remote-Local*—transfers control of the projector to a remote location.
- 8) *Douse-Show*—permits cut-off of the projected image by interposing a mechanical shutter in the optical path.

All operating controls are gated through inhibit circuits so that the function initially selected must complete its cycle before the mechanism will accept the next command.

Further, the nature of the circuit is such that the mechanism will respond but once to a switch closure. If a switch is held closed for a period longer than a change cycle, the device is inoperative until the switch is released.

AUTOMATIC LAMP CHANGE

One of the very important features of the TP-7 is the automatic lamp change mechanism. Its purpose is, of course, to prevent loss of picture due to failure of the projection lamp during a program. The lamp changer consists of two lamps mounted on a motor driven carrier; one lamp is located on the center line of the optical system and is the lamp in use. The second lamp is designated as the emergency lamp. Current to the lamp in service is sensed by its passing through the aperture of a saturable reactor. A pulse is induced in the secondary winding of the toroid for each zero axis crossing of the lamp current. This pulse indicates to the logic circuits that lamp current is flowing. When the lamp fails, the current and resultant pulse vanish. The absence of the pulse causes the logic circuits to turn on the power switching circuits which apply power to the changer motor. The mechanism is driven until the emergency lamp is in the proper position in the optical system. This position is sensed by a light switch, the output of which is connected to the

logic circuits. The signal from the switch causes the logic circuits to remove power from the motor and apply power to the new lamp. The burnt out lamp now becomes the emergency lamp. An emergency lamp failure tally located on the control panel is then lit indicating the filament of the lamp in the emergency position is open. The lamp changer cycles in approximately 0.75 seconds and the perception of a program interruption is hardly realized. A real economy in cost per hour operation of the projector is introduced by the coupling of the automatic changer and the quartz halogen projection lamp. The lamp is rated at 50 hours nominal life and, due to the halogen cycle which prevents blackening of the quartz wall, may be burnt to extinction. Ordinary tungsten lamps are very often removed from service before filament failure because of reduction of light output due to deposition of tungsten on the inside of the glass envelope.

VARIABLE DENSITY FILTER

The light output of the projector is 400 ft-candles measured on a 5.58-inch diagonal image at the field lens position. Measurement of uniformity of illumination shows less than 10% variation from center to corners. This high level of uniformity is maintained as the light output from the projector is attenuated through a 100:1 range in order to compensate for a difference in slide density. This range of attenuation is a function of the rotational position of a neutral variable density filter wedge located in each optical channel at the crossover point of the relay condensing system. The filter is coupled to and driven by a two phase motor to which a follower potentiometer is geared. The driving mechanism is part of a closed-loop servo system which comprises an amplifier and a control potentiometer so that the video signal corresponding to high light brightness is maintained at a constant level.

CONCLUSION

A basic consideration in the design concept of the slide projector was to ensure that any emergency situation arising from last minute program changes could be met. There is accessibility to all sides in the system including the two in the slide gates. Thus, any slide exclusive of the one being projected may be changed without disrupting the transmitted picture. Access to the slide gates makes it possible to by-pass the magazines and to manually insert emergency slides.

The design features embodied in the new RCA TP-77 Television Slide Projector brings to the broadcast industry a slide programming flexibility which to this time has not been available.

SPOT NAVIGATION SATELLITE SYSTEM

A system of synchronous satellites could provide world-wide navigation coverage to vehicles on earth or in near-earth orbits. The SPOT system, described in this paper, is such a system which could provide speed, position, and tracking information to a variety of users. The system is described along with the various possible modes of operation, traffic control problems, and communications link analyses.

J. BRECKMAN and J. D. BARNLA, Mgr.

*Navigation and Air Traffic Control
Systems Engineering, Evaluation and Research (SEER),
Moorestown, New Jersey*

THE DEVELOPMENT of synchronous satellites into reliable space platforms with a potential life of several years now has made possible vastly improved coverage capabilities of navigation system with a coordinated world-wide satellite system. Ideally, such a navigation system would perform the following functions:

- 1) Provide precision position, velocity, and (possibly) attitude to users on any part of the earth, and in near-earth orbits.

Final manuscript received July 15, 1967.

JEROME D. BARNLA received the BSEE degree from the City College of New York. Mr. Barnla then joined the General Electric Company where he took part in the advanced engineering program and a three year graduate level education program. In seven years with GE, Mr. Barnla had a variety of assignments in each of the military departments. As a project engineer with the Missile and Space Vehicle Department, he was responsible for leading preliminary design studies on weapon systems programs. Since joining RCA in 1961, Mr. Barnla has had a technical leadership role on a variety of assignments including Apollo, Saint, Mariner '69, Voyager, and SPADATS. In the past three years, Mr. Barnla was Program Director for (1) the Early Spring Mobility Study, (2) a comprehensive internally conducted study of ground based identification of missions in space, and (3) development of a semi-active guidance system for satellite interception. Recently, Mr. Barnla directed the advance research and technology satellite program concerned with a multi-mission synchronous satellite system. In the past eighteen months, Mr. Barnla has been leading a group of senior engineers in the area of satellite navigation and traffic control for both military and commercial application.

J. BRECKMAN received a BEE from Cooper Union in 1943 and an MSEE from the University of Pennsylvania in 1962. He is presently engaged in a doctorate program at the University of Pennsylvania. From 1943 to 1949 he designed test equipment and taught mathematics. While with the Signal Corps (1949-1954) he designed analog and digital computer systems. Since joining RCA in 1954, Mr. Breckman has designed digital control and data processing equipment for BIZMAC, served as chairman of the computer group for BMEWS, wrote the computer program for satellite observations in the BMEWS system, wrote the PAGE Program for the performance analysis of a total ground environment against a total satellite population, and invented the B-chart and developed its applications to radar scan design. Mr. Breckman was the 1963 candidate from the Defense Electronic Products for RCA's Outstanding Engineer of the Year award. He is presently Staff Systems Engineer, Space Operations, in the SEER organization. Mr. Breckman has been the technical director of a group engaged in concept and systems studies of satellite navigation.

- 2) Provide this information upon demand under all weather conditions to command-control centers for traffic control, stationkeeping, or monitoring of military vehicles on specific missions. The command centers may be stationary or in motion, and located in any part of the globe.
- 3) Provide communication links between command centers and vehicles in a network.
- 4) Accomplish the above in a secure manner in a hostile environment.

The feasibility of a world-wide synchronous-satellite navigation system depends on

- Cost of the system,
- Precision of the fix,
- Inherent reliability,
- Availability of the system,
- Time required to obtain a fix,
- Vulnerability to physical and electronic jamming,
- Degree to which existing components and systems can be used,
- Degree to which the system can be integrated into existing military complex,
- Sensitivity to atmospheric and propagation anomalies,
- Constraints imposed on the user,
- Flexibility to provide service to a large and diverse number of users, and
- Cost to the user, among many other factors.

The SPOT (speed, position, and track) navigation concept appears to offer attractive solutions to the spectrum of requirements imposed by military and commercial applications. Fig. 1 depicts some potential applications for the SPOT system.

BASIC PRINCIPLE

The principle involved in phase navigation is illustrated in Fig. 2. The center transmits an RF carrier modulated by a continuous tone; the tone may be con-

Fig. 1—Spot navigation system applications.

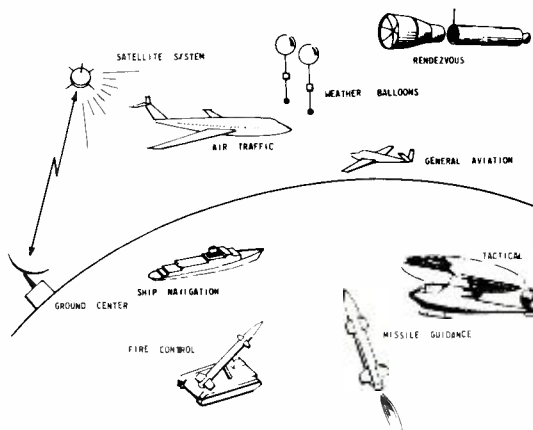
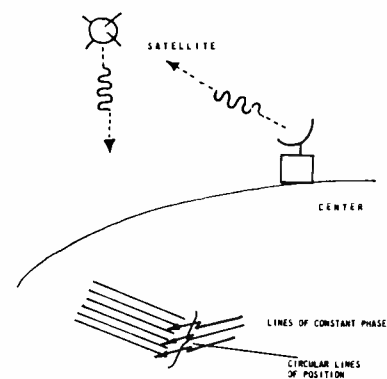

Fig. 2—Basic principle of phase navigation.



sidered as an envelope on the carrier (although an operational system may use phase modulation). The center signal is beamed at a near-synchronous satellite, where it is frequency translated and repeated toward the earth into the field of users. Hence this signal, originating at the center and repeated toward the earth, is called the *field signal*.

When the signal arrives back on the earth, points having the same slant range from the satellite will experience the same phase of the tone at every moment, since there are as many wavelengths from the satellite to one of these points as there are to another. Sets of such points may be connected into lines of equal phase, each of these being a circular line on the earth. If a particular user were to transpond the field signal back to the center via the satellite, the phase difference of the envelope, measured at the center between its signal generator and returned signal, will be an indication of the particular circular line of position (LOP) occupied by the user. This transponded signal is called the burst signal, because it will generally be returned in a burst, gated at the user.

FINE AND COARSE TONE

If the tone envelope were 10-kHz, for example, then LOPs differing in slant range by a half wavelength, or 8 nmi in this case, would return the same phase to the center. The strips between adjacent LOPs of the same phase are called bands. Hence, a 10-kHz tone would be satisfactory in determining the LOP of a user without ambiguity where the initial uncertainty in his LOP did not exceed the horizontal equivalent of 8 nmi in slant range. The 10-kHz tone may be thought of as a coarse, or resolving, tone whose primary function is to identify the lane of the user without ambiguity.

In addition to the resolving tone, the signal also carries a tone at a higher frequency, 300 kHz for example, whose half wavelength is about 1600 ft. This is the fine or tracking tone that subdivides each 10-kHz band into 30 lanes. A 3% measurement (1 part in 30) on the 10-kHz tone is sufficient to identify which lane is indicated by a particular cycle of the fine tone. If, in turn, the fine-tone phase is measured to 5%, the LOP of the user is selected to within the horizontal equivalent of less than 100 ft. Fig. 3 illustrates the relation between lane width, range precision, and tone frequency, assuming a capability to measure phase to 3%.

PASSIVE NAVIGATION — CIRCULAR MODE

Fig. 4 illustrates one of two general modes of operation wherein the user may operate passively to determine his own position. The position may be found

on-board automatically by a computer, or manually with the aid of charts, tables, and hand calculations. It is expected that large groups of users will operate with the system in this way, perhaps because they are not part of a control pattern, or because their mission requires passive navigation.

In the configuration shown, the user is assumed to know the location of his starting point with respect to the general grid he is about to traverse. He carries a local oscillator which generates tones of the same frequency as those on the field signal. In one channel, he adjusts the phase of this local tone to match that of the in-coming *A*-tone; in another channel, he matches the incoming *B*-tone. He now begins his trip.

As he moves off his initial *A*-LOP he will begin to accumulate a phase difference in his *A*-channel, designated by $\Delta\phi_A$. Similarly, he accumulates a $\Delta\phi_B$ in the *B*-channel. The number pair $(\Delta\phi_A, \Delta\phi_B)$ is a continuous statement in LOP coordinates of his position relative to the LOP grid he is traveling. Notice that his phase accumulations must keep account of the number of tone cycles traversed, as well as fractions thereof.

PASSIVE NAVIGATION — HYPERBOLIC MODE

In the self-navigation mode just described, the user was able to operate with two satellites, but he needed a local oscillator having either substantial long-term stability or a well-calibrated drift rate. Either one or the other is available to him in present-day oven-controlled crystal oscillators (his drift rate being recalibrated when he touches another known point in his itinerary). However, there is a mode of self navigation which makes use of a third satellite when it is available, and dispenses with the precision oscillator aboard the vehicle. This mode is illustrated in Fig. 5.

Here, the *A* and *B* phases are compared in one channel while the *A* and *C*

phases are compared in another. The *AB* phase difference available from the first channel defines a particular hyperbolic LOP; the *AC* difference from the second channel defines a second hyperbolic LOP whose intersection with the first establishes the user fix.

An alternative way of operating assumes the user starts his trip from a known point in the grid about to be traversed. At the start, each channel is brought to zero phase difference by an adjustable delay in the *A* tone; one in each channel. Now the trip begins and the accumulated phase difference in each channel is a coordinate in the LOP grid system, giving a continuous indication of the track traversed. In effect, the local oscillator of the previous mode has been exchanged for satellite *A* of the present mode.

TRAFFIC CONTROL

Fig. 6 shows the phase principle applied via two satellites simultaneously. It has been shown that one of these satellites, say *A*, results in the determination of a user LOP at the center. The addition of satellite *B* now gives a second LOP, whose intersection with the first establishes a fix of user position.

This Figure shows the basic configuration of a traffic control system. Field signals are generated at the center for repeat back to the earth via satellites *A* and *B* into a large field of users. These signals are uninterrupted and continuously available to every user simultaneously. From time to time, at intervals determined by data processing equipment at the center, a particular user is selected from the field to return a burst of field signal currently impinging on him.

While the antennas at the center are highly directional, the user in general will have a hemispherical antenna pattern. His burst of the *A*-field signal will return via *A*, and the burst of the *B*-field

Fig. 3—Tone ranging.

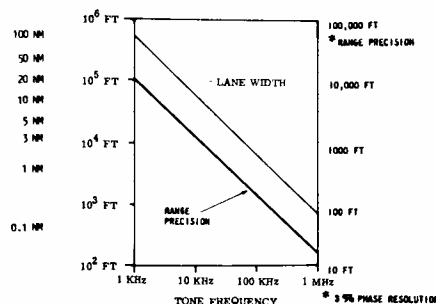
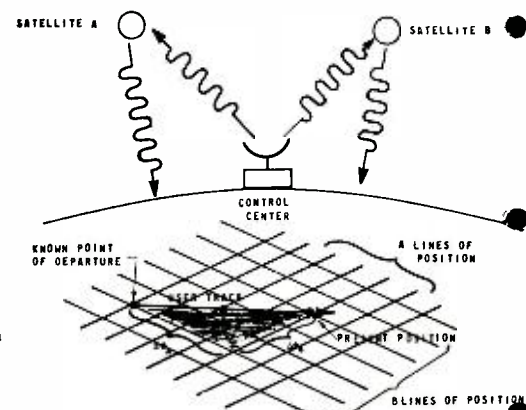

Fig. 4—Self navigation with local oscillator.



signal will return via *B*. The center now has the phase information to establish the user at the intersection of two circular LOPs.

The selection of a particular user from the field is accomplished by the transmission of a distinctive digital address which is recognized by that user and no other. Accompanying this address may be any of several digital control signals, to call for a particular receiver configuration at the user; or to display some selected information to him. At present, however, the chief concern is only with the control signal, which means in effect "return a burst *m* milliseconds long," where *m* might be 50, 100, 1000, . . . and may change from user to user or even from interrogation to interrogation of the same user.

The user's burst is accompanied by his digital address which identifies the source of the burst, thus providing the center with an authentication signal, confirming that the burst it is receiving at any time originated at the user intended. In addition to the identification, the user may send digital status and measurement data representing the configuration and status of this equipment, or some measurement on his ambient environment made enroute.

In an operational system, the whole process of interrogation via address and control, and reply via burst, identification, and status, will be automatic. The center data processor will decide the interrogation interval which will vary from user to user and even for a particular user, depending on the present state of knowledge of his track at the center or on changing requirements during a flight for fineness of detail; on similar grounds, the data processor will decide on the length of burst for any particular interrogation.

RELATIVE NAVIGATION

Fig. 7 shows the extension of the basic

system to include control of a cluster of the field via a local center. (This configuration may arise in control of incoming traffic at some terminal point.) The signal center serves primarily as the source of field signal only, the actual interrogation, computation, and tracking being done at the local center. Where the users are within line-of-sight of the local center, the return bursts may be via the line-of-sight path instead of the satellite. In this case, the LOPs defining the user are ellipses, with the satellite at one focus and the local center at the other. If the bursts are returned via the satellites, the LOPs are circles as before.

In any case, when the local center and its cluster of users are relatively close, errors due to satellite uncertainty tend to vanish, as well as errors due to refractive variations. Hence relative position finding under such circumstances may improve to the order of tens of feet, if satellite and refraction uncertainties are the limiting factors in absolute position-finding. In other words, the system described has an inherent precision-tightening characteristic in situations where measurement and maintenance of relative spacing are of primary concern.

SATELLITE ORBIT DETERMINATION

Fig. 8 illustrates the principle of satellite tracking, so that the satellite positions may be known continuously to a precision compatible with user-fix requirements. The center itself and two other fixed locations constitute a sub-class of user. The location of each of these stations is known to first-order precision in a geodetic frame, established either via conventional means or via geodetic satellite surveys. From time to time, the center interrogates each of these stations, requiring a burst of returned signal. The usual equations of position determination are now inverted at the center pro-

cessor—the inputs being ground station locations and the outputs being satellite location. Hence, the satellite-finding procedure is perfectly coherent from a signal and computation viewpoint with the user-finding procedure, and errors in user position due to satellite uncertainty are directly controllable by the tightness of the geodetic base.

FAIL-SOFT BACKUP

Any satellite system used for military navigation could be subjected to hostile interference and jamming, where possible. One way to implement the system to cope with deliberate interference is to equip each satellite with a self-contained oscillator, perhaps a ruggedized atomic clock (Fig. 9).

The self-contained package would be designed to go into operation wherever some activating code fails to appear on schedule. The circuitry carried aloft would be capable of generating tones identical to the field signal, and in addition would signal the entire field to revert to the self-navigation mode; of course, all vital vehicles will be equipped to do this. (In anticipation of such an emergency, all vital vehicles will also carry the latest hard-copy bulletin describing the satellite orbital motions.)

While up-link jamming effects may be effectively countered through elimination of the center-to-satellite link, down-link jamming effects may be reduced using narrow-beam user antennas.

SYSTEM INSTRUMENTATION

The user instrumentation for a self-navigation mode (Fig. 10) includes a hemispherical circularly polarized antenna (1500 MHz) which may be flush mounted for aircraft applications. The receiver consists of low-noise, high-gain, solid-state L-band circuitry. Carrier reference extraction is performed in a phase-lock loop to negate the effects of doppler shift. Coherent multiplication of the composite RF signal with the ex-

Fig. 5—Self navigation without local oscillator.

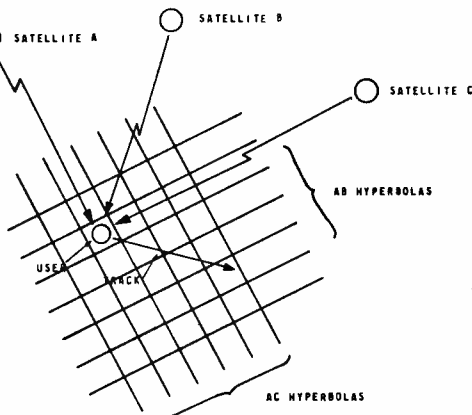

Fig. 6—Traffic control.

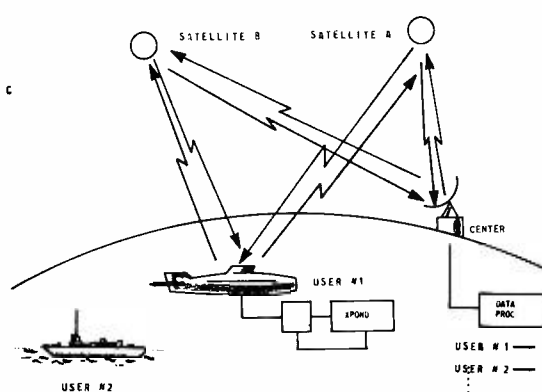
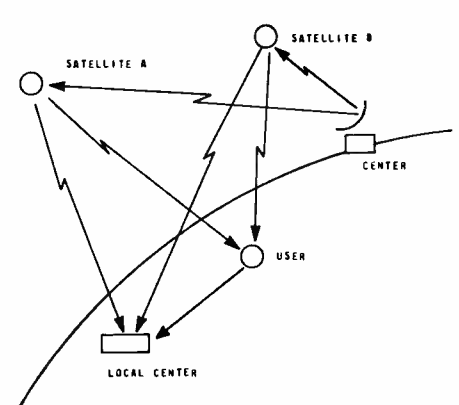

Fig. 7—Relative navigation.



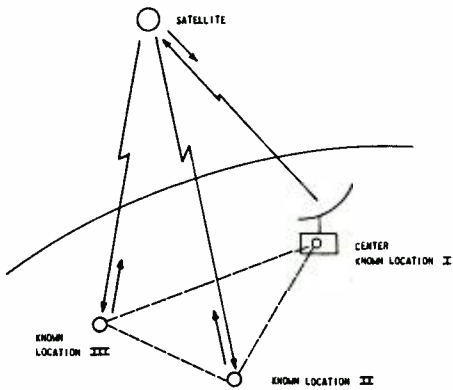

Fig. 8—Satellite tracking.

tracked carrier provides the tone demodulation. A post demodulation tone filter bandwidth of approximately 10 Hz insures a high signal-to-noise ratio at the output of the receiver.

Satellite Instrumentation is shown in Fig. 11. The satellite relay, typical of current communication satellite instrumentation, employs a low-noise hard-limiting receiver. The method of frequency sidestepping insures the frequency errors due to the L-band injection chain is effectively cancelled in an add-and-subtract process leaving only the residual in the 50-MHz crystal oscillator. Typically, 10 to 50 watts of RF power is available at the antenna terminals. Isolation of the receive and transmit functions is provided by an antenna filter diplexer. A 22° beamwidth assures earth coverage plus several hundred miles for low-orbit satellite applications.

The center instrumentation (Fig. 12)

TABLE I—Error Sources.

- PROPAGATION
 - MULTIPATH
 - REFRACTION
 - ATTENUATION
 - PATH LOSS
- SATELLITE UNCERTAINTY
- VELOCITY ERRORS
- GEOMETRIC DILUTION
 - SENSITIVITY COEFFICIENTS
 - ANGLE CROSSING
- FREQUENCY STABILITY
- USER HEIGHT
- FIGURE OF THE EARTH
- COMPUTATIONAL APPROXIMATIONS
- INSTRUMENTATION

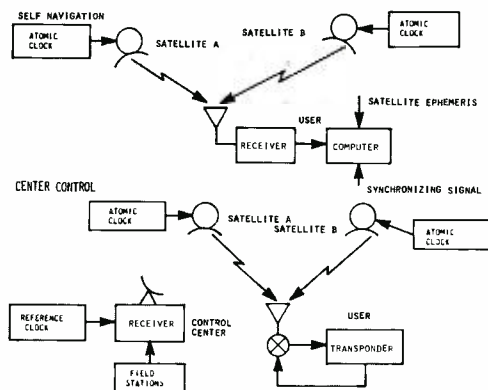

Fig. 9—Fail-soft mode.

provides for generation of the field signal and for receiver/computer functions in a traffic control mode. The coarse and fine tones are derived from a common atomic frequency standard, linearly added and angle modulated on a highly stable carrier oscillator. The RF power is amplified to a level of 100 watts and fed to the high-gain directional antenna via the antenna filter. The receiver, similar to that in the user instrumentation demodulates and processes the ranging tones, and a comparison is made with the standard. The phase of both tones is then processed in the signal processor.

SYSTEM PERFORMANCE

The accuracy to which the SPOT system can perform position measurements is a function of

- 1) Instrumentation characteristics (power, bandwidth, stability, etc.);
- 2) Navigation carrier and tone frequencies;
- 3) Propagation effects (refraction, multipath, faraday rotation, etc.);
- 4) Noise sources (cosmic, receiver, interference, etc);
- 5) Satellite and user deployment;
- 6) Satellite ephemeris uncertainty; and
- 7) User altitude and altitude uncertainty.

Table I is a summary of error sources which must be analyzed to estimate the accuracy of position fix for either active or passive users.

LINK ANALYSIS

Assuming a carrier frequency of 1600 MHz, Fig. 13 presents a sample link calculation for a passive mode of operation. With a combination of 100 watts transmitted power and a 2° antenna beamwidth, the 56 dBW effective power radiated achieves a hardwire link from control center to satellite. The 18 dB

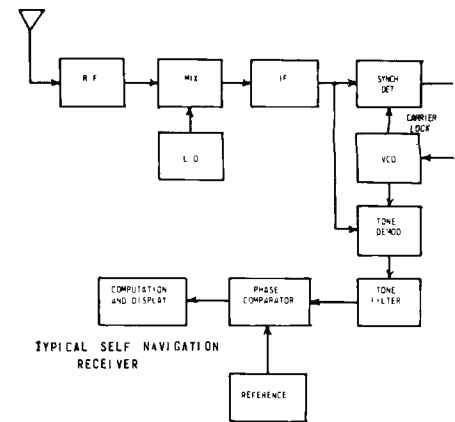

Fig. 10—User instrumentation.

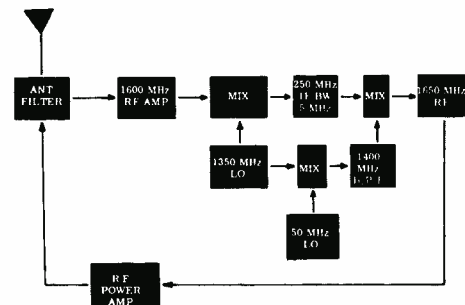

Fig. 11—Satellite instrumentation.

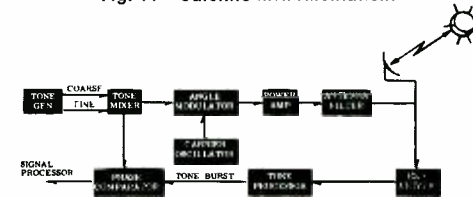

Fig. 12—Center instrumentation.

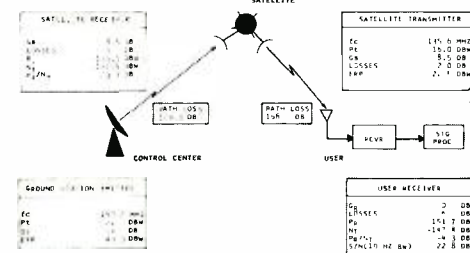

Fig. 13—Link analysis.

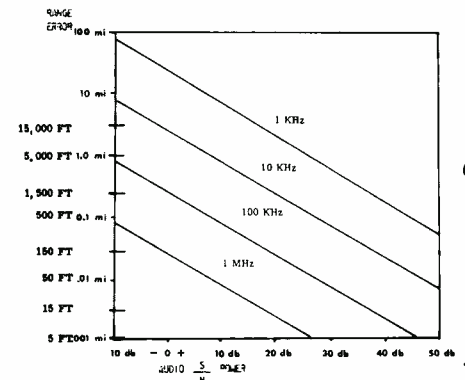

Fig. 14—Range error versus signal to noise.

ELEVATION ANGLE DEGREES	NORMAL IONOSPHERE DISTRIBUTION m ²	TROPO-SPHERE m ²	MULTIPATH/ NOISE m ²	EQUIPMENT m ²	SATELLITE RANGE ERROR m ²	TOTAL RANGE ERROR RMSE-m
1	990	81.8	176.4	17.5	400	40.8
5	840	3.3	51.4	17.5	400	36.2
10	604	0.4	37.3	17.5	400	32.6
15	318	0.2	33.3	17.5	400	27.7
45	57.4	0	30.0	17.5	400	22.4
90	20.7	0	30.0	17.5	400	21.6

TABLE II—Range Error Budget.

satellite antenna gain corresponds to a 22° earth-coverage beamwidth. The RF signal received at the satellite is frequency-translated and repeated at a 32 dBW level. The user antenna, providing a hemispherical coverage pattern combined with a receiver noise figure of 5 dB results in a signal-to-noise ratio of 22 dB for an integration time of 1/10 second.

Fig. 14 presents the effective range error as it varies with tone frequency and signal-to-noise ratio. For an upper tone frequency of 300 kHz and a signal-to-noise ratio of 22 dB, the range error due to noise is less than 50 ft.

RANGE-ERROR BUDGET

Table II presents a range-error budget for the instrumentation characteristics and carrier frequency previously discussed. A conservative estimate of ionospheric effects is implied by the assumption of a normal distribution. The total root-mean-square error due to equipment delay is estimated at a little over 4 meters. Due to the sensitivity of refraction, multipath, and satellite range errors to elevation angle, the data is presented as a function of elevation angle.

TRANSFORMATION OF RANGE ERRORS

In the immediate neighborhood of a user, the family of LOPs due to a satellite has three characteristic parameters of primary interest to the navigator:

- Value of LOP at the estimated position;
- Gradient, or density of lines in that neighborhood; and
- Direction of maximum gradient.

These characteristics depend on the coordinates of the satellite as viewed by the user for a circular system: the LOP value depends only on range; the gradient of lines depends on elevation angle; and the direction of maximum gradient depends only on azimuth angle.

When the random components of range error in the LOP families are normally distributed, the user's position in the horizontal plane is a two-dimensional normal distribution. The uncertainty in position estimate is characterized by an error ellipse.

Fig. 15 presents typical results of a computer simulation for the case of two synchronous, equatorial satellites deployed on the equator at 0° and 90° longitude.

For cases where the user height error is somewhat less than the total measurement error in range from the user to satellite, the dimensions of the position error ellipse can be scaled proportionately. Variations in user height from sea level to several hundred miles altitude have a negligible effect on the dimensions of the error ellipse.

POSITION-ERROR SUMMARY

Fig. 16 presents typical position performance for a passive mode of operation.

For this set of data, the range error budget presented in Fig. 14 as a function of elevation angle was used in a computer simulation.

Position-error performance for a traffic-control mode is approximately at the same level. For the active case, the transformation coefficients are one-half the passive mode values while range measurement errors are approximately twice the passive-mode values.

While providing coverage to every point on or near the surface of the earth, a global deployment of satellite is capable of providing transformation coefficients of one or less for passive hyperbolic users and two or less for circular passive users. Fig. 17 presents a typical deployment of 15 satellites giving global coverage and attractive position accuracy. Five satellites are equally spaced in each of three orthogonal orbits, one equatorial and two polar.

SUMMARY

Based on the studies completed to date, SPOT is a global, all-weather, always-available navigation system which gives near-instantaneous fixes or continuous tracks where desired. It can provide height, velocity, and automatic guidance and control signals as well as position. All of the technology needed to implement SPOT exists today.

The prospective field of applications for SPOT include: non-saturable air traffic control simultaneous with passive user operation; in-flight and terminal navigation; air and sea search and rescue; continuous flight logging; automatic guidance; near-earth satellite rendezvous and mid-course correction; ballistic missile insertion and re-entry; surface hazard markers; aerial survey; oceanographic and meteorological control; jam-resistant strategic and tactical military operations; maritime navigation; harbor control; and the navigation and control of land vehicles.

Fig. 15—Dimensions of error ellipse.

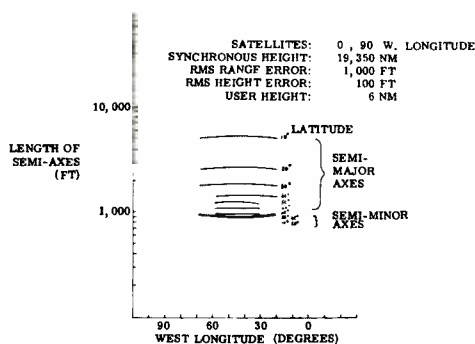

Fig. 16—Position error summary.

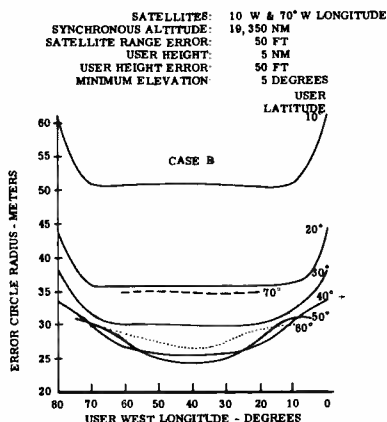
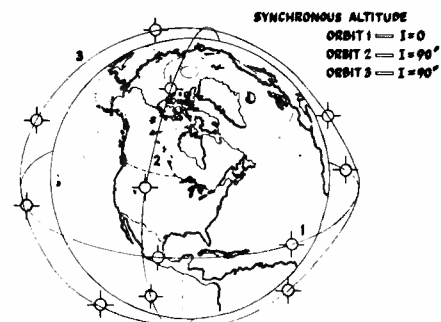

Fig. 17—Global satellite deployment.



A SIMPLIFIED METHOD OF CONDUCTING A DUAL RANDOM VIBRATION INTEGRATED SYSTEM TEST

In a radar system, the antenna assembly is usually mounted externally on the vehicle and the electronics assembly is mounted inside the vehicle. Ordinarily an assembly of this nature is vibration-tested at the assembly level and integrated only for electrical performance test after the dynamic tests. A more realistic vibration test method is to conduct an integrated random vibration/electrical performance test. Such a test can be accomplished easily with two vibration exciters and two random vibration consoles. However, the problem is that many laboratories may have more than one vibration exciter but, usually, only one random vibration console. This test was accomplished, successfully, at the RCA Aerospace Systems Division using two vibration exciters, one random console, and one magnetic tape recorder, with a pre-recorded spectrum signal on tape replacing the second random console.

JAMES G. COLT, Ldr.

*Environmental, EMI, and Packaging Engineering
Aerospace Systems Division
Burlington, Massachusetts*

IN A RENDEZVOUS RADAR SYSTEM, there are three basic assemblies: an antenna assembly, a rendezvous radar electronic assembly, and a transponder electronic assembly. Selected environmental tests were conducted individually on each assembly with specific inputs applied according to the required assembly specification. During the environmental testing, each assembly was electrically and/or mechanically operated while undergoing environmental exposure. Operationally, only during the electrical baseline tests are the three assemblies integrated and operated as one complete system. After the initial electrical baseline test is completed successfully, the system is separated with each assembly thereafter environmentally tested with its respective checkout test unit. This procedure is followed throughout the entire qualification environmental test program until a final system electrical performance test is completed.

Following the qualification test program, an electrical performance demonstration of the integrated Rendezvous Radar Antenna assembly and the Rendezvous Radar electronics assembly under simulated vibration conditions was required. Therefore, to demonstrate Rendezvous Radar Antenna assembly and Electronics performance during vibration, the assemblies were integrated electrically. Mechanically, the electronics and the antenna were mounted on separate shaker tables (vibration exciters). With only one random control

console available, the problem was to vibrate both assemblies simultaneously utilizing separate shaped random inputs. A description of the facilities and procedure used to solve this problem are given below.

TEST FACILITIES

The dual vibration testing of the electronics and antenna was performed at the RCA-Aerospace Systems Division Plant, Environmental Laboratory, Burlington, Mass. Two separate vibration systems were used; one to vibrate the antenna assembly at one random spectrum and the other to vibrate the electronics assembly at another random spectrum. Random vibration on the antenna was accomplished using an MB C126 vibration exciter, an MB T389 equalizer system, and MB T130MC sine/random control console, and an MB 4200 power amplifier. This system is rated at 9000 pounds peak sine force and 6500 pounds RMS force. It is completely automatic incorporating 80 contiguous filters for equalization in random vibration testing. Random vibration on the radar electronics was performed using the smaller vibration system composed of a Calidyne A174 vibration exciter, a CEC type VR2800 tape recorder, and a Westinghouse FG-11 power amplifier. This system is rated at 1500 pounds peak sine force and 1050 pounds RMS force.

The method employed to obtain a second random signal source (tape recorder) to drive a shaker system lacking an equalization system is explained best by briefly describing the function and

characteristics of the equalization system and the recording instrumentation. Automatic equalization is accomplished utilizing a multiband random equalizer where the frequency spectrum is divided into 80 narrow bands of 12.5, 25, and 50 Hz. Attenuators are provided in each band and the outputs of all bands are summed.

Many contiguous narrow bandpass filters are incorporated in this system where control of each increment of the spectrum is available. The controlled shaped spectrum is then amplified and introduced to the input of the power amplifier. This input to the power amplifier is recorded on tape (Fig. 1); the tape recorder is later used as the second random signal source. Prior to the tape recording process, a check of the desired spectrum shape was made through the use of the parallel filter analyzer also incorporated in the equalizer system. This analyzer employs a series of parallel filters, each sampling a portion of the spectrum. The DC output of each filter is commutated and plotted on an X-Y recorder. A graphical presentation of the required spectrum then becomes readily available prior to the recording process.

PRE-RECORDING THE SPECTRUM INPUT ON MAGNETIC TAPE

One of the most important factors for pre-recording the proper spectrum input on magnetic tape was to use the best representative mechanical model of the electronics assembly. Fortunately, a similar model of the radar electronics in this checkout procedure could be used to obtain the required shape of the input spectrum later to be applied to the actual test item (electronic assembly) of the dual integrated test. The electronics and vibration fixture combination mounted in the most sensitive axis were secured to the small shaker armature with a driver (Fig. 2). Accelerometers were mounted at pre-selected points to control and monitor the input spectrum. Signal conditioning equipment in the form of charge amplifiers were used to obtain high signal levels and to obtain the optimum in signal-to-noise ratio. Voltage outputs from the charge amplifiers and the multiband equalizer were fed to a multichannel CEC type VR2800 tape recorder. A specified random vibration input spectrum (Fig. 3) was applied to the electronics mounting flange using the random console.

A playback of the input spectrum via the control accelerometer and charge amplifier through the console analyzer verified the input spectrum shape (shown in Fig. 4). The input to power amplifier (compensated by the equalizer) was recorded on tape. The tape recorder was then used as the second random driv-

ing source. A playback of the control accelerometer through the console analyzer verified the input spectrum shape obtained previously by using the random console (Fig. 5). About twenty minutes of this recording was made for later testing. The tape recorder, in this case, replaced an entire equalization system. It provided the second driving source and a means to go ahead with vibration testing the electrically integrated assemblies simultaneously.

VIBRATION TESTING THE INTEGRATED SYSTEM

Testing the integrated system progressed with minimum problems once the second random driving source was obtained on magnetic tape. The antenna and the electronics were electrically and mechanically setup as shown in Fig. 6; the antenna was attached to the larger shaker in its most sensitive vibration direction as shown in Fig. 7. All assemblies were electrically operated and dual random vibration testing was conducted on the antenna electronic assemblies. Functionally, the integrated system worked well during the random vibration exposure.

CONCLUSION

Tape recordings of vibration levels induced by missile firings and the like are nothing new in the vibration field. What has been described above is one method that can be employed by the numerous environmental test laboratories in the country. In recent years, automatic equalization became the optimum method for vibration testing, compared to the time-consuming, peak-notch sine method of equalization. Once the automatic equalization is programmed, and a very representative mechanical test specimen is used, it is only necessary to tape the voltage output from the automatic equalizer thereby utilizing the tape as a control console.

J. G. COLT, received the BS in Mechanical Engineering from Northeastern University in 1954 and his MS in Mechanical Engineering from New Mexico Mechanical and Agricultural Arts College in 1957. From 1955 to 1956, he was in the US Army as a Vibration Analyst of the NIKE and Corporal Missile Systems. He was also an engineer in charge of NIKE in-flight vibration program. From 1957-1961 he worked at the AVCO Corp, as group Ldr., responsible for re-entry vehicle system test and evaluation; and associated ground support systems. He joined RCA in 1961 in the P706 project management office responsible for environmental test planning and environmental testing of the P-706 final stage vehicle. He was in the LEM program management office responsible for LEM environmental test requirements. He was placed in charge of the environmental testing engineering group and the environmental laboratory at Burlington. He is a registered Professional Engineer for the state of Massachusetts. He has published a paper for the 27th Shock and Vibration Symposium, entitled "Multi-purpose T-fixtured"

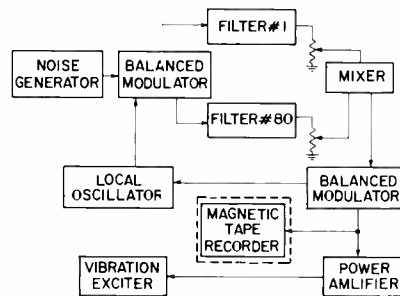

Fig. 1—Block diagram of equalization and recording system.

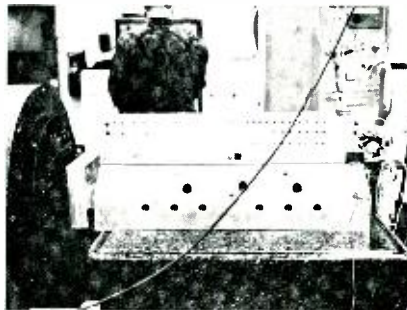

Fig. 2—Electronics vibration test arrangement.

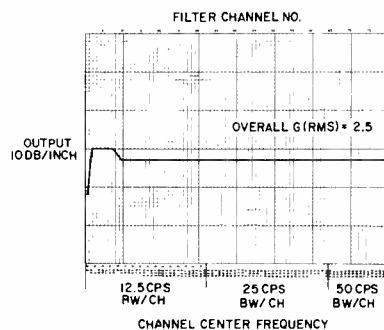

Fig. 3—Electronics random vibration input spectrum.

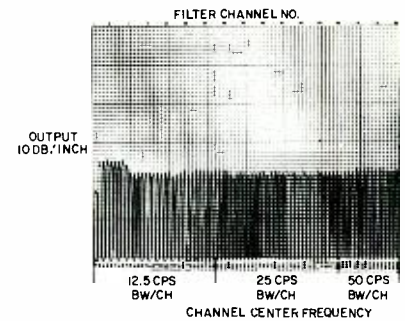

Fig. 4—Shaped spectrum utilizing vibration console to drive shaker.

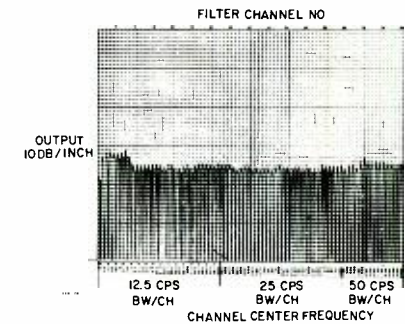

Fig. 5—Shaped spectrum utilizing tape recorder to drive shaker.

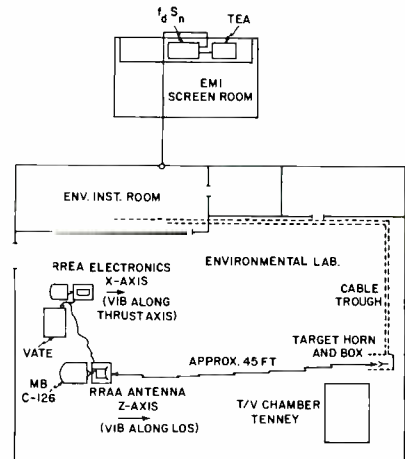

Fig. 6—Integrated mechanical and electrical test arrangement.

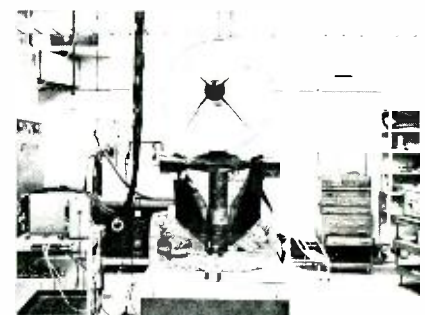
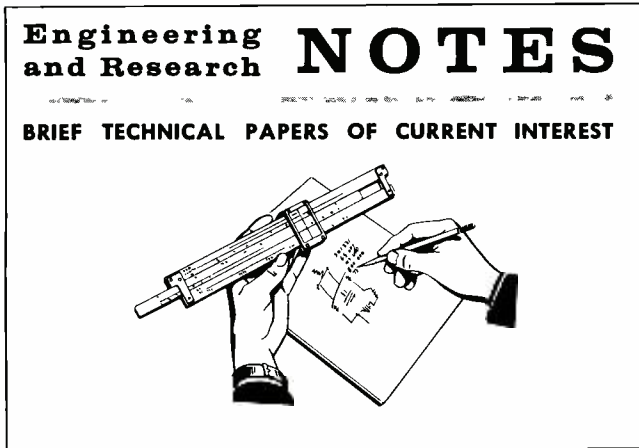

Fig. 7—Antenna vibration test arrangement.



An Analysis of Economic System Subdivision

R. J. TREADWELL, *Leader, Magnetic Recording Group, Astro-Electronic Division, DEP, Princeton, N. J.*



A simple analysis of the most economic subdivision of a complex system into units for manufacture and test can be derived from assumed relationships between costs of fabrication and test, complexity, and the probability that individual elements are faulty.

The difficulty in making things of great complexity is in getting them to work after fabrication: the trick is division. Success can be achieved by dividing a system into a number of manageable portions, each of which may be checked before assembly into the whole. This concept, while far from new, is an important secret of civilization. By means of division of labor, man has accomplished notable works.

How is the division best made? What rules exist for reducing the complex to the comprehensible? There are, of course, the natural and obvious divisions: 1) Division by skill or trade (let all the brick-laying be done by specialists), 2) Division by function (separate the left speaker amplifier from the right), 3) Quantizing (divide the work into increments that can be performed by one man or by a group—a favorite topic of management study from Moses to Parkinson), 4) Division by units which can be handled by an available transportation system (ranging from a man-pack to a crane), 5) Division into parts which are within the capacity of a manufacturing process or machine.

The common factor for these rules is that they are changeable and thus arbitrary, for several reasons: 1) The demarcation between skills is not sacrosanct. 2) Changing techniques can increase human capabilities. 3) The capacity of transportation systems is constantly increasing. The capacity of machines and processes is similarly growing. As always, the most powerful arbiter is the economic one. In a competitive environment, due to a process of elimination, the division that results in the lowest-priced system will prevail.

Is there an analytic approach to the problem of economic division which will provide an alternative to the long road of evolutionary *cut and try*? It is common for work to be checked for correctness at the completion of a defined task. For example, an electronic circuit board will be tested after it is assembled and wired. If it functions correctly, the next stage of assembly or processing will occur. If it does not function correctly, either the fault will be located and repaired or the work will be scrapped if rework is uneconomic or impossible (as with microelectronic semiconductor chips). In either eventuality there is an economic penalty.

If the building blocks are made small or the chance of individual work elements or parts being at fault is low, the yield of the building-block fabrication process will be high, but many building blocks will have to be made and assembled for each system. If the building blocks are made large or the chance of faulty elements is high, the yield of the building block fabrication process will be low. However, at some building-block size between these two extremes, costs will be a minimum.

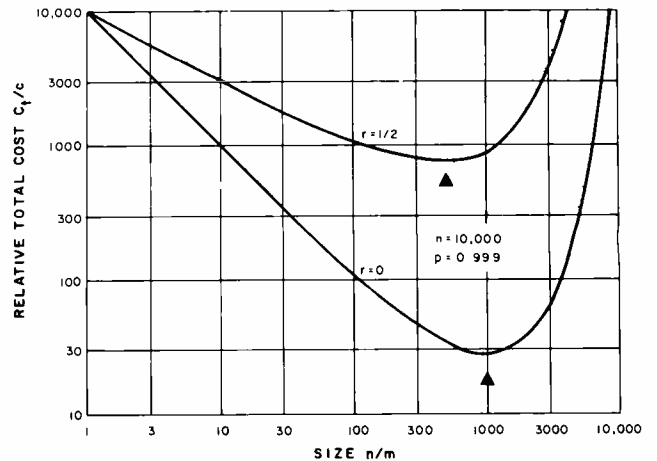

Fig. 1—Set yield as a function of set size for a probability of 0.999 that an element is correct.

Consider n elements in m sets, each of n/m elements, and assume that the cost, C_o , of manufacture, test, and assembly into the n array is proportional to the r^{th} power of the set size: $C_o = c(n/m)^r$, for $0 < r < 1$. Let the probability that an element is correct be p , and the probability that an element is incorrect be q ; therefore, $q = 1 - p$. The probability that the set is all correct or the set yield is $Y = p^{n/m}$. This relationship for $q = 0.001$ is shown in Fig. 1. Therefore, the true set cost:

$$C_s = c(n/m)^r / p^{n/m} \tag{1}$$

Therefore, the total cost, C_t , of the array is:

$$C_t = mc(n/m)^r / p^{n/m} \tag{2}$$

The relative total cost is:

$$C_t/c = m(n/m)^r / p^{n/m} = n(n/m)^{r-1} / p^{n/m} \tag{3}$$

The relative total cost is shown in Fig. 2 for a 10,000-element system with a probability of 0.001 that an element is incorrect for two values of r : 0 and 0.5. At the minimum cost point,

$$d(C_{t,r})/dm = 0$$

or

$$p^{n/m} d\{m(n/m)^r\}/dm = m(n/m)^r d(p^{n/m})/dm.$$

The optimum value, (n/m) optimum, therefore is:

$$(n/m) \text{ optimum} = (r-1) / \log p \tag{4}$$

or, if q is sufficiently small (substantially less than 1), the optimum value is:

$$(n/m) \text{ optimum} = (1-r) / q. \tag{5}$$

Substituting this in the yield equation gives:

$$Y \text{ optimum} = p^{(r-1)/1-rq}$$

or

$$Y \text{ optimum} = e^{-r}. \tag{6}$$

Substituting (n/m) optimum in the relative cost equation gives:

$$(C_t/c) \text{ minimum} = n(e \log p / r - 1)^{1-r} \tag{7}$$

or for $q \ll 1$

$$(C_t/c) \text{ minimum} = n(eq/1-r)^{1-r}. \tag{8}$$

Whenever a problem is subjected to mathematical analysis for the first time, the results fall into two categories: those which were expected, and those from which we learn something new.

Fig. 2 indicates that there is less risk in choosing a smaller rather than a larger size of building block. This is certainly common experience. Eq. 8 indicates that the minimum total cost increases as the ratio of defective to good elements increases. For a building-block cost independent of size ($r = 0$), there is direct proportionality, but for large values of r , there is less effect.

As the defective-element ratio approaches zero, the optimum building-block size approaches the maximum real value, n . But, as r approaches 1 (as the cost of the building-block becomes more nearly proportional to size), the optimum building-block size approaches a minimum real value of 1. These facts may be concluded from Eqs. 4 or 5. The simplicity of the optimum building-block equation (Eq. 5) is perhaps surprising; for a value of $r = 0$, the optimum element size becomes $1/q$. Eqs. 7 and 8 indicate that the

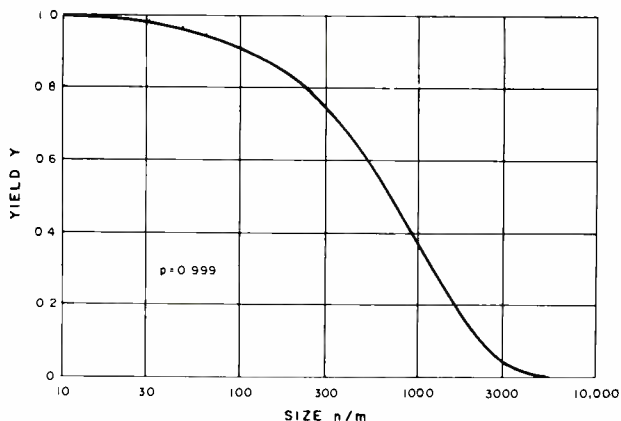

Fig. 2—Relative total cost as a function of set size for a system with 10,000 elements having a probability of 0.999 that an element is correct.

minimum total cost is directly proportional to the total array size, n . This is true even if the building block cost is independent of size.

The optimum yield, Eq. 6, is the most unexpected relationship to emerge from the analysis. First, because optimum yield is a function of r only, being independent of p or q . Second, except when $r = 1$, the optimum yield is not 1. Third, because it is simple. When $r = 0$, the optimum yield becomes $1/e$, the surprisingly low value of 36.8 percent. Engineers who have been exposed to life on the shop floor often wonder why the components are designed to be so complex that there are problems with every other one. The low value of optimum yield would indicate that this is a condition which can be expected.

Direct application of this analysis is practicable in a few instances. In the manufacture of integrated circuits and semiconductor arrays, the product is sufficiently homogeneous to ensure a uniform value of q throughout the system (q itself is a property of the basic material and is known with some degree of accuracy). Also the costs for the manufacturing processes should be sufficiently well known to establish the exponent r .

Considering electronic equipment and systems on a larger scale, application of this simple analysis is practicable in the formulation of qualitative guide-lines for system division. But precise application would require a more thorough and detailed analysis.

Pulse Amplification and Shaping with the Versatile IC CA3035

W. R. WALTERS,

Communications Systems Division, Camden, New Jersey



New developments in linear integrated circuits are breaking the cost barrier between IC's and transistors. For example, the RCA CA3035 is a low cost IC designed primarily to act as a TV remote control amplifier. It also can amplify and shape the signals for many other transducers. The three circuits described in this note were developed for applications in a tape recorder. With very little if any changes, they could be adapted to similar applications.

Schmit Trigger

The CA3035 is actually three individual amplifiers, each with a gain of over 40 dB. By connecting two of these amplifiers with some positive feedback as shown in Fig. 1, AC signals as low as 0.1 Vpp can be shaped into pulses with risetimes in the 500-ns region.

The RC circuit on the input acts as a noise filter and the component values depend on the condition of the signal being processed. The DC coupling between AMP 1 and AMP 2 insures good low frequency processing. The input impedance is high (approximately 50K) and the output impedance is low.

High gain amplifier

The second circuit is a high gain transducer amplifier with a bias adjustment to eliminate baseline noise. This configuration uses all the internal amplifiers and one external one. It will amplify and shape signals that are 10 mV in amplitude and will eliminate baseline noise up to nearly the actual signal level, depending on the relative frequencies of each. Again the DC coupling between the AMP 2 and the external amplifier and between the external amplifier and AMP 3 insures good low-frequency processing. The AC coupling between AMP 1 and AMP 2 can be used because the signal is not saturated here. The resistors in parallel with this coupling capacitor control the bias to AMP 2 and can be adjusted to fire AMP 2 at different signal levels. The input impedance is high (approximately 50K) and the output impedance is low. The external transistor is used here simply because the application called for a positive pulse out with each positive voltage swing of the transducer.

High gain one-shot multivibrator

This circuit uses one external transistor as an output driver because the internal amplifiers are not connected in the standard order. This is done because the one-shot feedback circuit should work into a fairly high impedance. The capacitor, resistor and diode at the output of the input pulse amplifier differentiate and then pass only the positive pulse. This means only negative-going input signals will trigger the circuit. Also, because of the positive bias at pin one, the positive trigger pulse at the diode must overcome this bias to pass thru the diode. Therefore, this design also acts as an isolator from random input noise. The 470-kilohm and 1000-ohm resistors act as bias resistors. The 470-kilohm resistor supplies the bias for AMP 1 and the 1000-ohm resistor supplies the bias for AMP 3. The 1000-ohm value is selected so that AMP 3 is biased all the way on. When AMP 1 is triggered, its output goes negative at pin three. This in turn clamps AMP 3 all the way off, and its output goes high. The DC coupling between pins 3 and 6 insures the one-shot action. As the output at pin 7 goes positive, the positive feedback loop formed by the 178-kilohm resistor and the 1000 μ f capacitor transforms the positive edge to pin one and holds the circuit with a positive output until the feedback RC time constant allows the bias at pin one to reach a sufficiently low level so that the circuit goes back to the normal level. The 4.7-kilohm resistor acts as AMP 3's collector load resistor and the 2.2-kilohm as the external emitter-follower load resistor.

Concluding remarks

For pulse amplification and shaping, the CA3035 can provide low cost, high gains, small board area, and reliability.

One final word on stray oscillations caused by the high gain and the bandwidths involved. Don't load down your circuit with capacitors until you have tested under conditions similar to your final circuit. Layout and loading conditions may be enough to "quiet" the circuit. A coax cable on the output may be sufficient. Faulty scoping can cause no end of troubles with circuits like these.

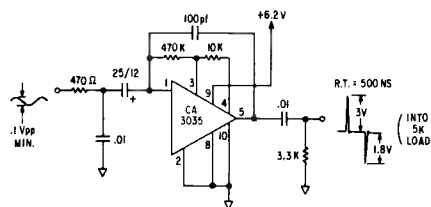

Fig. 1—Schmit trigger.

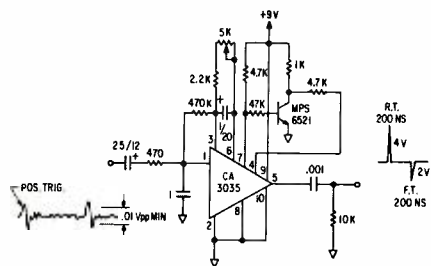

Fig. 2—High gain transducer amplifier.

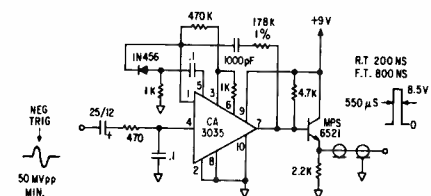

Fig. 3—High gain one shot.



RCA
RADIO CORPORATION OF AMERICA
RCA LABORATORIES

AEROSPACE
SYSTEMS DIVISION



DIGITAL SERIES BRANCH TELEVISION
TRANSMISSION FROM SPACECRAFT

REPRINTS OF RCA ENGINEER ARTICLES

Articles from the RCA ENGINEER are available for reprinting either on a single-article basis or as a booklet devoted to a specific theme, facility, or technology. The RCA ENGINEER itself cannot be distributed outside RCA, but reprints of articles, which can be supplied economically and quickly may be distributed to customers, opinion leaders, prospective employees, or students.



ANY ARTICLES from past RCA ENGINEER issues are available for reprinting. Articles may be reprinted individually or several articles may be grouped together (and mixed from several issues) to form a reprint booklet. Covers for reprints may be tailored to your own use. The RCA ENGINEER editorial staff will provide assistance on such matters as cover layout and utilization of reprints.

The RCA ENGINEER editorial office administers all policy on reprint content, availability, and utilization since additional changes must be made to the articles before they can be distributed. Reprints can be obtained only through the RCA ENGINEER editorial office.

HOW REPRINTS ARE USED

The various divisions of RCA use over 100,000 copies of reprints of RCA ENGINEER articles each year. Such reprints range from simple, two-page leaflets to 88-page booklets with full-color covers. Reprints supplied by RCA Staff Technical Publications are inexpensive and may be used in numerous ways:

- 1) As information brochures or descriptive bulletins;
- 2) To display engineering and technical skills;
- 3) For marketing and sales mailings and handouts;
- 4) For mailings to prospects, customers, and opinion leaders;

- 5) For answering any inquiries that require technical explanations;
- 6) For use with commercial and government proposals; and
- 7) To give to personnel groups for orientation, training, and recruiting.

Various types of reprints recently produced are pictured at the top of this page.

COVERS

Single Articles

On single-article reprints, a simple title-page imprint (article title, author, RCA logotype, and division) is included when a blank page is available. For economy, reprints are prepared in increments of four pages each; thus, a three-page article would be printed as a four-page reprint with the extra page used as a cover. In a four-page article, the cover information is placed on the title page of the article unless the separate title page is requested; the four-page article is then handled (and priced) as an eight-page reprint.

Booklets

On the booklet reprints, covers are custom-designed to suit the "theme" of the articles, using typography and artwork to suit. These booklets also can utilize previous RCA ENGINEER covers in either full color or in black-and-white. Cover messages, marketing contacts, or other additional information

appropriate to the purpose of the booklet may be placed on the inside front and back covers.

COST AND DELIVERY

Delivery

Four- and eight-page reprints can be supplied within two weeks of the receipt of the order. Reprint booklets are available on a four- to eight-week time cycle, depending on the complexity of the additional cover material. Rush schedules may affect price and should be handled on an individual basis.

Cost

Approximate prices for various reprints are tabulated below.

HOW TO ORDER

All reprints are ordered from the RCA ENGINEER Editorial Office, Radio Corporation of America, Bldg. 2-8, Front and Cooper Sts., Camden, N.J. For rush orders, phone WO 3-8000, Ext. PC 3396. The following information must be supplied with each order:

- 1) Article or articles desired;
- 2) Special instructions on cover requirements or special information to be added;
- 3) Quantity desired;
- 4) Delivery requirements (time and place); and
- 5) Account No. (not a purchase order).

Reprint Price List

	Size of Reprint (pages)	Quantity							Additional 1000's
		100	500	1000	2500	5000	7500	10,000	
self cover	2	\$ 34.50	\$ 41.00	\$ 47.00					\$ 17.50
	4	57.50	66.65	80.00					27.50
	8	128.00	148.00	174.00					57.00
	12	165.00	195.00	230.00					82.50
	16		230.00	267.00	\$ 368.00	\$ 552.00	\$ 697.95	\$ 852.00	67.15
with 1-color enamel cover	32		510.00	598.90	847.00	1271.00	1651.50	2049.00	160.63
	48		682.50	800.40	1111.00	1662.75	2179.35	2690.50	212.02
	64			985.40	1388.00	2074.00	2687.70	3320.00	262.48
	72			1127.40	1526.00	2320.00	2980.80	3683.50	291.52
	80			1182.90	1635.00	2467.00	3186.90	3939.00	312.00
	88			1325.40	1797.00	2710.00	3499.35	4326.00	343.01
	96			1380.40	1906.00	2875.00	3676.80	4582.00	363.48
<i>Cost for a 4-color cover: Add this cost to the price shown above for reprints with 1-color enamel covers (color covers are picked up from an existing RCA ENGINEER cover).</i>			223.00	219.60	225.75	248.00	161.10	169.60	4.23

Extra typesetting, at cost, is added to the above prices (e.g., for an added table of contents in booklets).

PEN and



PODIUM

**COMPREHENSIVE SUBJECT-AUTHOR INDEX
to
RECENT RCA TECHNICAL PAPERS**

Both published papers and verbal presentations are indexed. To obtain a published paper, borrow the journal in which it appears from your library or write or call the author for a reprint. For information on unpublished verbal presentations, write or call the author. (The author's RCA Division appears parenthetically after his name in the subject-index entry.) For additional assistance in locating RCA technical literature contact: RCA Staff Technical Publications, Bldg. 2-8, RCA, Camden, N. J. (Ext. PC-4018).

This index is prepared from listings provided bimonthly by RCA Division-Technical Publications Administrators and Editorial Representatives—who should be contacted concerning errors or omissions (see inside back cover).

Subject index categories are based upon the Thesaurus of Engineering Terms, Engineers Joint Council, N. Y., 1st Ed., May 1964.

SUBJECT INDEX

Titles of papers are permuted where necessary to bring significant keyword (s) to the left for easier scanning. Authors' division appears parenthetically after his name.

ACOUSTICS

(theory & equipment)

SPEECH PROCESSING Techniques and Applications—H. F. Olson, H. Belar, E. S. Rogers (Labs., Pr.); *IEEE Trans. on Audio and Electroacoustics*, Vol. AU-15, No. 3, 9/67

ANTENNAS

HIGH-GAIN UHF-TV ANTENNAS, Design Considerations for—Dr. M. S. Siukola (BCD, Gibbs.); *IEEE Western Conf.*, Los Angeles, Cal., 11/9/67

VHF-TV PANEL ANTENNA, A New—D. A. Brawn (BCD, Gibbs.); *AFCEC Mtg.*, Wash., D.C., 11/16/67

CHECKOUT

(& maintenance)

ATE DESIGNER: Programmer or Systems Engineer?—F. Liguori (ASD, Burl.); *IEEE Automatic Support Systems for Advanced Maintainability*, St. Louis, 11/7-9/67; *Symp. Record* (67-31)

TESTING COMMUNICATIONS EQUIPMENTS on DIMATE, Programs for—R. N. Knox (ASD, Burl.), W. Morris (USAECOM); *IEEE Automatic Support Systems for Advanced Maintainability*, St. Louis, 11/7-9/67; *Symp. Record* (67-24)

CIRCUIT ANALYSIS

CLASS C TRANSISTOR AMPLIFIERS AND FREQUENCY MULTIPLIERS, A Nonlinear Theory of—R. G. Harrison (RCA Victor Co., Ltd., Montreal); *IEEE J. of Solid-State Circuits*, Vol. SC-2, No. 3, 9/67

REMOTE PROGRAMMING OF MULTIVIBRATOR, Circuit Permits—R. L. Aiello (CSD, Cam.); *Elect. Des.*, 11/22/67

CIRCUITS, INTEGRATED

DIGITAL INTEGRATED CIRCUITS with MOS Transistors—J. J. Gibson (Labs., Pr.); *IEEE Seminar*, Princeton, N.J., 11/28/67

INTEGRATED CIRCUITS and Multiplexing Technique Reduces Size, Weight and Cost—A. A. Paris (CSD, Cam.); *Office of Naval Research Reviews*, 11/67

INTEGRATED CIRCUIT—Another Friend for the Broadcaster—R. N. Hurst (BCD, Cam.); *IEEE*, Greensboro, N.C., 11/8/67

LARGE SCALE INTEGRATION, High Yield Redundant Processing for—C. B. Herzog (Labs., Pr.); *NEREM-67*, Boston, Mass., 11/1-3/67

LARGE-SCALE INTEGRATION, System Architecture for—H. R. Beelitz, H. S. Müller, R. J. Linhardt (Labs., Pr.); *Fall Joint Computer Conf.*, Anaheim, Cal., 11/14-16/67

LINEAR INTEGRATED CIRCUITS—J. P. Keller (ECD, Som.); *IEEE Lecture Series*, New York City, 11/14/67

MONOLITHIC DESIGN—M. V. D'Agostino (ECD, Som.); Rutgers, New Brunswick, N.J., and Kearfott, Little Falls, N.J., 11/2, 7, 14, 21/67

RELIABILITY CHARACTERISTICS of Integrated Circuits—D. I. Troxel (CE, Cam.); *WESTCON Conf. of IEEE*, San Francisco, Cal., 8/22-25/67

CIRCUITS, PACKAGED

MULTILAYER LAMINATES, PC Materials and Evaluation Methods—F. H. Morris (CE, Cam.); *Electronic Packaging and Production*, 12/67

COMMUNICATION, DIGITAL

Will All Communications by Digital by 1980?—E. M. Bradburd (CSD, Cam.); Wash., 10/16/67

COMMUNICATIONS COMPONENTS

CLASS C TRANSISTOR AMPLIFIERS AND FREQUENCY MULTIPLIERS, Nonlinear Theory of—R. G. Harrison (RCA Victor Co., Ltd., Montreal); *IEEE J. of Solid-State Circuits*, Vol. SC-2, No. 3, 9/67

GUNN OSCILLATORS, Pulsed Epitaxial GaAs—S. Y. Narayan, B. E. Berson (ECD, Pr.); *NEREM*, Boston, Mass., 10/2/67; *NEREM Digest*, 11/67

IFF/ATC TRANSPONDER in a Satellite Communications Link for Aircraft Traffic Control, Application of the—B. W. MacDermid (CSD, Cam.); *IEEE Communications Technology Group*, Burl, Mass., 11/19/67; *Thesis for MSEE*, U. of Penn.

PARAMETRIC UPCONVERTER, Intermodulation Distortion Improvement in—E. Markard, P. Levine, B. B. Bossard (CSD, Cam.); *Proc. of IEEE (Correspondence)* Vol. 15, No. 11, 11/67

TWT's FOR SPACE SYSTEMS, Application of—G. Kadar, G. Koch, H. Brown (RCA Victor Co., Ltd., Montreal); 1967 International Electron Devices Mtg., Wash., 10/19/67

VARIABLE MULTIPLIERS, High-Power—C. Sun (ECD, Pr.); *NEREM*, Boston, Mass., 11/2/67; *NEREM Digest*, 11/67

COMMUNICATIONS SYSTEMS

ANTI-JAM COMMUNICATIONS Systems—M. Ferysaka (AED, Pr.); Princeton U. E.E. Grad. Seminar Eng. Quadrangle, Princeton, N.J., 11/27/67

ELECTRONIC JAMMING PENETRATION, Some Unique Approaches to—T. B. Howard, J. L. Christensen, E. C. Farnett (MSR, Mrstin.); *Missile Electronic Warfare Tech. Mtg.*, White Sands Missile Range, New Mexico, 11/1-2/67; *Classified Symp. Record*

2 GHz TELECOMMUNICATIONS SYSTEM, A New—C. R. Hogge, Jr. (BCD, Cam.); *National Electronics Conf.*, 10/24/67

COMPUTER STORAGE

CRYOELECTRIC CONTENT-ADDRESSABLE MEMORIES Utilizing Flux-Shuttling Non-Destructive Readout—S. A. Keneman (Labs., Pr.); 1967 Applied Superconductivity Conf., Austin, Texas, 11/6-8/67

FLUX-SHUTTLING—A New Method for the Non-Destructive Readout of Superconductive Memory Cells—A. R. Sass, E. M. Nagle (Labs., Pr.); *IEEE Trans. on Magnetics*, Vol. MAG-3, No. 3, 9/67

LAMINATED MEMORY ARRAYS, Low-Drive, Temperature-Stable Ferrite for—R. L. Harvey, I. Gordon, A. D. Robbi (Labs., Pr.); *IEEE Trans. on Magnetics*, Vol. MAG-3, No. 3, 9/67

RANDOM-ACCESS MEMORY, Cryotron-Based—A. R. Rass, W. C. Stewart, L. S. Cosentino (Labs., Pr.); *IEEE Trans. on Magnetics*, Vol. MAG-3, No. 3, 9/67

COMPUTER SYSTEMS

LARGE-SCALE INTEGRATION, High Yield Redundant Processing for—C. B. Herzog (Labs., Pr.); *NEREM-67*, Boston, Mass., 11/1-3/67

LARGE-SCALE INTEGRATION, System Architecture for—H. R. Beelitz, H. S. Müller, R. J. Linhardt (Labs., Pr.); *Fall Joint Computer Conf.*, Anaheim, Cal., 11/14-16/67

DISPLAYS

HIGH-POWER SINGLE-FREQUENCY LASER and its Application to Holography—I. Gorog, F. W. Spong (Labs., Pr.); *American Physical Soc. Mtg.*, N.Y., 11/16-18/67

DOCUMENTATION (& information science)

DOCUMENT GENERATION—A Fruitful Field for Information System Improvement—M. Hollander (AED, Pr.); *American Documentation Institute 1967 Annual Conv.*, New York City, 10/22/67

The Dry Run—C. W. Fields (CSD, Cam.); *IEEE Industry and General Applications Symp.*, Pittsburgh, 10/3/67

EDUCATION

INNOVATION IN EDUCATION, Industrial Involvement in—J. Miedzinski (RCA Victor Co., Ltd., Montreal); *C.C.R.E. Symp. on Education and the New Technology*, Ottawa, Ontario, 11/22-24/67

RCA and the Community—H. Snell (CSD, Cam.); *Kiwanis Club*, Vineland, N.J., 9/14/67

ELECTROMAGNETIC WAVES

HARMONIC ANALYSIS, Graphical Solutions to—W. A. DiMarzio (ASD, Burl.); *IEEE Electromagnetic Compatibility Symp. Record No. 9*, IEEE Group on EMC, 7/18-20/67 (67-17)

NON-RECIPROCAL WAVE PROPAGATION Using InSb at Room Temperature—K. Suzuki, R. Hirota (Labs., Pr.); *Mtg. of the Institute of Electrical Communication Engineers of Japan*, Tokyo, Japan, 11/67

PHASE SUBTRACTION for Increasing the Range of a Phase-Locked Loop, Use of—A. Acompora, A. Newton (CSD, Cam.); *National Electronic Conf.*, Chicago, 10/25/67

ENERGY CONVERSION (& power sources)

NIMBUS B POWER SUPPLY—I. Brown (AED, Pr.); *EASTCON '67*, Wash., D.C., 10/16/67

BATTERY CHARGING SYSTEMS for Spacecraft, The Analysis of Voltage-Limited—J. Bacher, D. Rusta (AED, Pr.); *EASTCON '67*, Wash., D.C., 10/16/67

ENVIRONMENTAL ENGINEERING

METEOROID ENVIRONMENTS in the Solar Systems, Correlation of—V. Head (AED, Pr.); *AIAA J.*, 11/67

DUAL RANDOM VIBRATION INTEGRATED SYSTEM TEST, a Simplified Method of Conducting a—J. G. Colt (ASD, Burl.); 37th Shock and Vibration Symp., 10/24/67, Orlando, Fla.; *Shock and Vibration Information Center Bulletin* (67-41), 11/67

RF FURNACE for Maintaining Temperature Differences between Parallel Susceptors—L. A. Murray, P. A. Hoss, J. J. Rivera (ECD, Som.); *J. of Scientific Instruments*, 12/67

SHOCK AND VIBRATION Instrumentation and Analysis Techniques (Lecture No. 81)—A. Baran (AED, Pr.); *Institute of Environmental Sciences*, Phila., Pa., 12/4/67

HUMAN FACTORS (physiological & psychological)

EVALUATING SAFETY by System States and Life Cycle Phases—B. Tiger, S. Canale (CE, Cam.); 11th Human Factors Soc. Mtg., 9/26/67, Boston, Mass.; Northeast Chapter, System Safety Soc., Panel Discussion, Valley Forge, Pa., 11/1/67

SYSTEM SAFETY (Keynote Address and Summary Statement)—S. Canale (CE, Cam.); System Safety Session of 11th Human Factors Soc. Mtg., Boston, Mass., 9/25/67; *Hazard Prevention and Nuclear Weapon Safety*, 12/67

SYSTEM SAFETY Measurement and Control—S. Canale (CE, Cam.); *EIA G-48 System Safety Engineering Mtg.*, Denver, Colo., 11/7/67

LABORATORY TECHNIQUES

INTERMODULATION TESTING of Stereo Phono-graph Pickups, High-Frequency—J. G. Woodward, R. E. Werner (Labs., Pr.); *J. of Audio Engineering Soc.*, 4/67

SENSITOMETRIC MEASUREMENTS on Kodak Ortho Resist at Microsecond Exposure Times—D. L. Ross (Labs., Pr.); *Soc. of Plastics Engineers*, Ellenville, N.Y., 11/6-7/67

SPARK-SOURCE MASS SPECTROGRAPHY, the Current Status of—J. R. Woolston (Labs., Pr.); North Jersey Mass Spectrometry Discussion Group, Seton Hall, S. Orange, N.J., 11/13/67

X-RAY METHODS for Investigating Thin Films and Plating, Review of—E. P. Bertin (ECD, Hr.); *Eastern Analytical Symp.* New York City, 11/7-10/67

LASERS

BULK FIELD-IONIZED GaAs, Stimulated Emission from—P. D. Southgate (Labs., Pr.); 1967 IEEE Semiconductor Laser Conf., Las Vegas, Nevada, 11/30/67

ELECTRON BOMBARDED SEMICONDUCTOR LASERS, Far-Field Patterns in—F. H. Nicoll (Labs., Pr.); IEEE Semiconductor Laser Conf., Las Vegas, Nevada, 11/28/67

GaAs INJECTION LASERS, Observations Concerning Self-Damage in—H. Kressel (Labs., Pr.); IEEE Semiconductor Laser Conf., Las Vegas, Nevada, 11/25/67

GaAs LASER AMPLIFIERS—W. F. Kosonocky, R. H. Cornely (Labs., Pr.); 1967 IEEE Semiconductor Laser Conf., Las Vegas, Nevada, 11/23/67

GaAs LASER DIODES Operating at Room Temperature, High Power Pulsed—H. Nelson (Labs., Pr.); *Proc. of IEEE*, 8/67

GaAs OSCILLATOR, CW Three-Terminal—K. G. Petzinger, A. E. Hahn, A. Matzelle (Labs., Pr.); IEEE Trans. on Electron Devices, 7/67

HIGH-POWER SINGLE-FREQUENCY LASER and Its Application to Holography—I. Gorog, F. W. Spong (Labs., Pr.); American Physical Soc. Mtg., N.Y., 11/16-18/67

LASER DIODES, Temperature Dependence of Emission Efficiency and Lasing Threshold in—J. I. Pankove (Labs., Pr.); IEEE Semiconductor Laser Conf., Las Vegas, Nevada, 11/28/67

LASER RANGEFINDERS, Tradeoff Analysis of Neodymium and Ruby—E. Kornstein (ASD, Burl.); NEREM, Boston, Mass., 11/1-3/67; '67 NEREM Record (67-27)

MULTILAYER GaAs INJECTION LASER—W. F. Kosonocky, R. H. Cornely, I. J. Hegji (Labs., Pr.); IEEE Semiconductor Laser Conf., Las Vegas, Nevada, 11/23/67

LINGUISTICS (& speech recognition)

CLIPPED SPEECH, Performance Evaluation of—H. E. Rose (CSD, Cam.); Air Force Cambridge Research Center, Boston, Mass., 11/8/67

PATTERN RECOGNITION TECHNIQUES to the Evaluation of Speech Recognition Systems, Application of—P. W. Ross, E. S. Rogers (Labs., Pr.); '67 Conf. on Speech Communication and Processing, Air Force Cambridge Research Lab., Bedford, Mass., 11/6-8/67

SPEECH PROCESSING Techniques and Applications—H. F. Olson, H. Belar, E. S. Rogers (Labs., Pr.); IEEE Trans. on Audio and Electroacoustics, Vol. AU-15, No. 3, 9/67

MANAGEMENT

AIRCRAFT MARKET for Recorders—D. T. Hoyer (CSD, Cam.); *Aerospace Technology*, 10/9/67

DESIGN REVIEW—R. D. Mitchell (MSR, Mrstn.); 1967 Annual Symp. on Quality Control Methods and Management, Villanova, 11/1/67; *Proceedings*

Do You Find It Difficult to Compare Competing Products from Manufacturers' Data?—(Forum Comments) F. H. Morris (CE, Cam.); *Insulation*, 11/67

MATHEMATICS

HARMONIC ANALYSIS, Graphical Solutions to—A. W. DiMarzio (ASD, Burl.); IEEE Electromagnetic Compatibility Symp. Record No. 9, IEEE Group on EMC, 7/18-20/67 (67-17)

PERMUTATION AND COMBINATION THEOREMS, Generalized—V. Chew (RCA Service Co., Missile Test Project, Fla.); *American Statisticians*, Vol. 21, No. 5, 12/67

MECHANICAL DEVICES

TAPERED TOWERS with Variable Wall Thickness—Dr. R. Pshunder (MSR, Mrstn.); *J. of the Structural Division Proc. of the American Soc. of Civil Engineers*, 10/67

MEDICAL ELECTRONICS

ELECTROCOAPTATION OF BLOOD VESSELS, Physical Factors in—F. L. Hatke (MedElec, Tr.); Dr. B. Siegel (Woman's Medical College, Phila.); *Archives of Surgery*, Vol. 95, 7/67

ELECTROTHERMAL CLOSURE OF BLOOD VESSELS, Role of Apposition Pressure and Energy in—F. L. Hatke, L. E. Flory (MedElec, Tr.); Dr. B. Siegel (Woman's Medical College, Phila.); 7th International Conf. on Medical and Biological Engineering, Stockholm, 8/18/67

MEDICAL ENGINEERING is an International Affair—R. S. Holmes (MedElec, Tr.); *Montreal*, 7/29/67

OPTICS

SENSITOMETRIC MEASUREMENTS on Kodak Ortho Resist at Microsecond Exposure Times—D. L. Ross (Labs., Pr.); Soc. of Plastics Engineers, Ellenville, N.Y., 11/6-7/67

PARTICLE BEAMS

SPOTLIGHT NONCOHERENT EMISSION—A. Blicher (ECD, Som.); *IEEE Spectrum (Correspondence)*, 12/67

STREAMING CARRIERS in the Presence of Collisions, Small-Signal Power Flow and Energy Density for—B. Vural, S. Bloom (Labs., Pr.); IEEE Trans. on Electron Devices, 7/67

PLASMA PHYSICS

SOLID STATE PLASMA in a Magnetic Field, Direct Measurement of the Diffusion of—C. J. Goldsmith (Labs., Pr.); American Physical Soc. Mtg., Plasma Physics Division, Austin, Texas, 11/8-11/67

SOLID STATE PLASMA Perpendicular to Magnetic Field, Diffusion of—G. J. Goldsmith (Labs., Pr.); American Physical Soc. Mtg., Plasma Physics Division, Austin, Texas, 11/8-11/67

PROPERTIES, ATOMIC

EXACTLY SOLUBLE PSEUDOPOTENTIAL for Atoms and Semiconductor Impurities—R. M. Williams (Labs., Pr.); American Physical Soc. Mtg., N.Y., 11/16-17/67

IMPACT IONIZATION in ZnSe and Comparison with CdS—R. Williams (Labs., Pr.); *Physics Letters*, Vol. 25A, No. 6, 9/25/67

PROPERTIES, MOLECULAR (& crystallography)

CONDUCTING STRONTIUM TITANATE SINGLE CRYSTALS, Evaporated Metallic Contacts to—J. E. Carnes, A. M. Goodman (Labs., Pr.); *J. of Applied Physics*, Vol. 38, No. 8, 7/67

GaSb-InSb ALLOYS, Conduction Bands in—I. Kudman, T. E. Seidel (Labs., Pr.); *J. of Applied Physics*, Vol. 38, No. 11, 10/67

MELT-GROWN n-TYPE Ge-DOPED GaAs, Radiative Recombination in—H. Kressel (Labs., Pr.); *J. of Applied Physics*, Vol. 38, No. 11, 10/67

MONOCLINIC RARE EARTH SESQUISULFIDES, Structure Determination and Crystal Preparation of—J. G. White, P. N. Yocom, S. Lerner (Labs., Pr.); *Inorganic Chemistry*, Vol. 6, 1967

PRESSURE-SINTERED GaSb-FaAs Alloys—Densification and Thermoelectric Properties—P. R. Sahn, T. V. Pruss (Labs., Pr.); *Trans. of Metallurgical Soc.*, Vol. 239, 10/67

PROPERTIES, SURFACE (& thin films)

PHASE TRANSFORMATION OF As₂Se₃ and Sb₂Se₃ Films—M. D. Coutts, E. R. Levin (Labs., Pr.); *J. of Applied Physics*, Vol. 38, No. 10, 9/67

LAYERED SYSTEM OF CADMIUM SULFIDE ON GERMANIUM, Elastic Surface Waves in—P. Schnitzler (Labs., Pr.); *Applied Physics Letters*, Vol. 11, No. 9, 11/1/67

VACUUM DEPOSITION OF HOMOEPITAXIAL SILICON, Low-Temperature—L. R. Weisberg (Labs., Pr.); *J. of Applied Physics*, Vol. 38, No. 11, 10/67

WATER-Vapor-Contaminated Re-Nb Alloy Surface, the Work Function Behavior of a—R. Williams (Labs., Pr.); *Surface Science*, Vol. 9, No. 1, 1/68

PROPERTIES, CHEMICAL

INTERFACE BETWEEN ZnSe AND AN ELECTROLYTE, Chemistry and Electrical Properties of the—R. Williams (Labs., Pr.); *J. of Electrochemical Soc.*, Vol. 114, No. 11, 11/67

NEW TERNARY COMPOUNDS, Cd₂S₁₅ and Cd₂Si₅Se₈—E. Kaldis, L. Krausbauer, R. Widmer (Labs., Pr.); *J. of Electrochemical Soc.*, Vol. 114, No. 10, 10/67

PRECIPITATION TITRATION of Molybdate, Tungstate, Permanganate, and Fluoride with Lead—K. L. Cheng, B. L. Goydich (Labs., Pr.); American Chemical Soc. Mid-West, Regional Mtg., 11/67

SOLUBILITY OF IRON IN TiO₂—J. P. Wittke (Labs., Pr.); *J. of American Ceramic Soc.*, Vol. 50, No. 11, 1967

PROPERTIES, ELECTRICAL

INTERFACE BETWEEN ZnSe AND AN ELECTROLYTE, Chemistry and Electrical Properties of the—R. Williams (Labs., Pr.); *J. of Electrochemical Soc.*, Vol. 114, No. 11, 11/67

PROPERTIES, MAGNETIC

LAMINATED MEMORY ARRAYS, Low-Drive, Temperature-Stable Ferrite for—R. L. Harvey, I. Gordon, A. D. Robbi (Labs., Pr.); IEEE Trans. on Magnetics, Vol. MAG-3, No. 3, 9/67

PROPERTIES, OPTICAL

OPTICAL STUDIES of Domain Dynamics in GdIG—T. J. Nelson, G. Warfield (Labs., Pr.); IEEE Trans. on Magnetics, Vol. MAG-3, No. 3, 9/67

PHOTOELECTRONS in the Silver-Oxygen-Cesium Photocathode, Origin of—A. H. Sommer (ECD, Pa.); *RCA Review*, 12/67

RADIO BROADCASTING (mass-media)

INTEGRATED CIRCUIT—Another Friend for the Broadcaster—R. N. Hurst (BCD, Cam.); IEEE, Greensboro, N.C., 11/8/67

Experiences in Ham Radio—S. Wolff (CSD, Cam.); South Jersey Radio Club, 10/26/67

TWO WAY RADIOS and Public Safety, Metropolitan Transit Companies—G. R. Kamerer (BCD, Md/Lds); IEEE, Cherry Hill, N.J., 11/6/67; IEEE, New York, 12/6/67

RECORDING, AUDIO (equipment)

STEREO PHONOGRAPH PICKUPS, High-Frequency Intermodulation Testing of—J. G. Woodward, R. E. Werner (Labs., Pr.); *J. of Audio Engineering Soc.*, 4/67

RECORDING, IMAGE (equipment)

HUE AND SATURATION ERRORS in TV Tape Recording, Correction of—J. R. West (BCD, Cam.); NABE, Denver, Colo., 11/8/67; IEEE, Los Angeles, Cal., 11/9/67

IMAGE SENSOR, Self-Scanned Solid-State—P. K. Weimer, G. Sadasiv, J. E. Meyer, L. Meray-Horvath, W. S. Pike (Labs., Pr.); *Proc. of IEEE*, Vol. 55, No. 9, 9/67

RELIABILITY (& quality control)

ELECTRODEPOSITION OF GOLD for High-Reliability Devices—W. Alina, E. Buckley (ECD, Som.); *Products Finishing*, 11/67

INEXPENSIVE AUDIO POWER AMPLIFIERS Can be Reliable—J. C. Sondermeyer (ECD, Som.); *The Electronic Engineer*, 12/67

RELIABILITY CHARACTERISTICS of Integrated Circuits—D. I. Troxel (CE, Cam.); WEST-CON Conf. of IEEE, San Francisco, Cal., 8/22-25/67

RELIABILITY PREDICTION can Contribute to the Assurance and Control of Product Assurance—B. Tiger (CE, Cam.); Panel Discussion, "Pro and Con of Reliability Prediction," IEEE Product Assurance Conf. Exhibit, N.Y., 11/2-3/67

REPAIRABLE AGGREGATES, Yield of—A. Krell (CSD, Cam.); *IEEE PMP Trans.* 9/67

TAPE CONTROL: A Key to Cost Prevention in Manufacturing—A. G. Cattell (CSD, Cam.); *Standards Engineering*, 12/67

VARIABLE INSTRUCTION COMPUTER, Reliability Aspects of the RCA/USAF—E. H. Miller (ASD, Burl.); *IEEE Trans. Electronic Computers*, 10/67 (67-8)

SOLID-STATE DEVICES

FREQUENCY RESPONSE OF SCR's, Analysis of the Effect of Charge Storage on the—H. J. Kuno (ECD, Pr.); *Proc. of the IEEE (Correspondence)*, 8/67

GaAs OSCILLATOR, CW Three-Terminal—K. G. Petzinger, A. E. Hahn, A. Matzelle (Labs., Pr.); IEEE Trans. on Electron Devices, 7/67

GUNN OSCILLATORS—F. Sterzer (ECD, Pr.); Naval Research Laboratory Electronics Division Seminar, Wash., D.C., 11/30/67

GUNN OSCILLATORS, Pulsed Epitaxial GaAs—S. Y. Narayan, B. E. Berson (ECD, Pr.); NEREM, Boston, Mass., 10/2/67; *NEREM Digest*, 11/67

IMAGE SENSOR, Self-Scanned Solid-State—P. K. Weimer, G. Sadasiv, J. E. Meyer, L. Meray-Horvath, W. S. Pike (Labs., Pr.); *Proc. of IEEE*, Vol. 55, No. 9, 9/67

LASER DIODES, Temperature Dependence of Emission Efficiency and Lasing Threshold in—J. I. Pankove (Labs., Pr.); IEEE Semiconductor Laser Conf., Las Vegas, Nevada, 11/28/67

MOS FIELD-EFFECT TRANSISTOR—R. W. Ahrons (ECD, Som.); IEEE Seminar, Princeton, N.J., 11/27-29/67

MOS FIELD-EFFECT TRANSISTOR: Device Characterization—F. P. Heiman (Labs., Pr.); Princeton IEEE Section Seminar, Princeton, N.J., 11/27-29/67

SILICON FLEXODE—An Adaptive p-n Junction Device—R. Stander (Labs., Pr.); *Solid-State Electronics*, Vol. 10, No. 12, 12/67

VARIABLE MULTIPLIERS, High-Power—C. Sun (ECD, Pr.); NEREM, Boston, Mass., 11/2/67; *NEREM Digest*, 11/67

SPACE COMMUNICATION (mass-media & scientific)

COMMUNICATIONS Between Low Altitude Spacecraft and Stationary Satellites, Multiple Problems in—S. Durrani, H. Staras (AED, Pr.); IEEE, URSI Fall Mtg., Ann Arbor, Mich., 10/16/67

MILITARY COMMUNICATIONS via Satellites: Equipment—W. J. Connor (CSD, Cam.); WFLN Radio, Phila., 12/16/67

MILITARY COMMUNICATIONS via Satellites: Theory and Techniques—W. J. Connor (CSD, Cam.); WFLN Radio, Phila., 12/2/67

SATELLITE COMMUNICATIONS Link for Aircraft Traffic Control, Application of the IFF/ATC Transponder in a—B. W. MacDermid (CSD, Cam.); IEEE Communications Technology Group, Burl., Mass., 10/19/67; Thesis for MSEE, U. of Penn.

TWT's FOR SPACE SYSTEMS, Application of—G. Kadar, G. Koch, T. Brown (RCA Victor Co., Ltd., Montreal); 1967 International Electron Devices Mtg., Wash., 10/19/67

SPACE NAVIGATION (& tracking)

VARIABLE POINT GUIDANCE for Space Missions, Recent Developments in—E. Capen, J. Camiel, A. Schneider (ASD, Burl.); *J. of Spacecraft and Rockets*, 11/67 (65-24)

SPACECRAFT (& space missions)

BATTERY CHARGING SYSTEMS for Spacecraft, Analysis of Voltage-Limited—J. Bacher, D. Rusta (AED, Pr.); EASTCON '67, Wash., D. C., 10/16/67

INJECTION OF SYNCHRONOUS SATELLITES, Flight Plans for the—E. Capen, J. Camiel, A. Schneider (ASD, Burl.); *J. of Spacecraft and Rockets*, 10/67 (65-35)

METEOROID ENVIRONMENTS in the Solar Systems, Correlation of—V. Head (AED, Pr.); *AIAA J.*, 11/67

NIMBUS B POWER SUPPLY—I. Brown (AED, Pr.); EASTCON '67, Wash., D.C., 10/16/67

SPACECRAFT DESIGN Problems—S. Goldfarb (AED, Pr.); Rutgers Student Branch IEEE, New Brunswick, N.J., 10/11/67

SPACE TELEMETRY, TRACKING, AND COMMUNICATIONS, Meeting Challenges for the '70's in—F. A. Hartshorne (CSD, Cam.); IEEE Aerospace Electronic Systems Group, Houston, 10/12/67

SPACECRAFT INSTRUMENTATION

PHOTOGRAPHIC TELEMETRY DATA from the Lunar Orbiter Spacecraft, Demodulation of—P. Stahl, H. Goldman (CSD, Cam.); IEEE EASTCON, Wash., 10/16/67

SPACECRAFT VIDEO REFERENCE TIMER Using a Universal MOS Master Chip Array, Design of—H. Derbert, B. Schubert, E. Keohane (AED, Pr.); EASTCON '67, Wash., D.C., 10/16/67

STANDARDIZATION

EQUIPMENT AND CARTRIDGES, The Status in the Development of Standards and Compatibility for—R. C. Moyer (RCA Victor Record Div., Indpls.); Tape Cartridge Forum, N.Y. Hilton Hotel, 10/17/67

METROLOGIST, Measure Thyself—H. S. Ingraham, Jr. (CE, Cam.); Panel Discussion, "Has Metrology Come of Age?", Twenty-Second Annual Instrument Soc. of American Conf., Chicago, Ill., 9/11-14/67

SUPERCONDUCTIVITY (& cryoelectrics)

ANISOTROPIC STRUCTURED CELL, Cryoelectric Storage Element of Unexcelled Performance—R. A. Gange (Labs., Pr.) 1967 Applied Superconductivity Conf., Austin, Texas, 11/6-8/67

CRYOELECTRIC CONTENT-ADDRESSABLE MEMORIES Utilizing Flux-Shuttling Non-Destructive Readout—S. A. Keneman (Labs., Pr.); 1967 Applied Superconductivity Conf., Austin, Texas, 11/6-8/67

CRYOTRON-BASED Random-Access Memory—A. R. Sass, W. C. Stewart, L. S. Cosentino (Labs., Pr.); *IEEE Trans. on Magnetics*, Vol. MAG-3, No. 3, 9/67

FLUX-SHUTTLING—A New Method for the Non-Destructive Readout of Superconductive Memory Cells—A. R. Sass, E. M. Nagle (Labs., Pr.); *IEEE Trans. on Magnetics*, Vol. MAG-3, No. 3, 9/67

HIGH-CURRENT-DENSITY HIGH-FIELD SUPERCONDUCTIVE MAGNETS, Stabilization of—E. R. Schrader (ECD, Hr.); Applied Superconductivity Conf., Austin, Texas, 11/6-8/67

NORMAL-STATE PROPERTIES of β -Tungsten Superconductors, Effect of Fermi-Level Motion on—R. W. Cohen, G. D. Cody, J. J. Halloran (Labs., Pr.); *Physical Review Letters*, Vol. 19, No. 15, 10/9/67

SUPERCONDUCTING Nb_3Sn , Energy Gap of—D. R. Bosonworth, C. W. Cullen (Labs., Pr.); *Physical Review*, Vol. 160, No. 2, 8/10/67

SUPERCONDUCTIVE TUNNELING, Device Applications of—B. N. Taylor (Labs., Pr.); 1967 Applied Superconductivity Conf., Austin, Texas, 11/6-8/67

VAPOR-DEPOSITED Nb_3Sn RIBBONS—H. C. Schindler (CED, Hr.); Applied Superconductivity Conf., Austin, Texas, 11/6-8/67

TELEVISION BROADCASTING (mass-media)

BURBANK SWITCHING CONTROL—J. L. Wilson (NBC, N.Y.); International Broadcast Convention, London, 9/22/67

COLOR TELEVISION BROADCASTING, Experiences in—Edward P. Bertero (NBC, N.Y.); Scandinavian Color Television Symp., Helsinki, Finland, 9/8/67

HUE AND SATURATION ERRORS in TV Tape Recording, Correction of—J. R. West (BCD, Cam.); NAEB, Denver, Colo., 11/8/67; IEEE, Los Angeles, Cal., 11/9/67

TELEVISION EQUIPMENT (non-mass-media)

SPACECRAFT VIDEO REFERENCE TIMER Using a Universal MOS Master Chip Array, Design of—H. Derbert, B. Schubert, E. Keohane (AED, Pr.); EASTCON '67, Wash., D.C., 10/16/67

STRATOSCOPE II Integrated Television System—A. D. Cope, A. D. Luedicke (ECD, Lanc.); American Astronomical Soc. Mtg., Phila., Pa., 12/5-7/67

TELEVISION RECEIVERS (mass-media)

WIRED TV, Standards for—E. J. Forbes (BCD, Cam.); Cable TV Association Mtg., San Diego, Cal., 11/13/67

TRANSMISSION LINES (& waveguides)

CASSEGRAIN MONOPULSE FEED SYSTEM, An Improved—C. E. Profera (MSR, Mrstn.); 17th Annual Symp. on USAF Antenna R&D, U. of Ill., 11/14-16/67; *Proceedings*

AUTHOR INDEX

Subject listed opposite each author's name indicates where complete citation to his paper may be found in the subject index.

AEROSPACE SYSTEMS DIVISION

Camiel, J. J. space navigation
Camiel, J. J. spacecraft
Capen, E. B. space navigation
Capen, E. B. spacecraft
Colt, J. G. environmental engineering
DiMarzio, A. W. electromagnetic waves
DiMarzio, A. W. mathematics
Knox, R. N. checkout
Kornstein, T. lasers
Liguori, F. checkout
Miller, E. H. reliability
Morris, W. checkout
Schneider, A. space navigation
Schneider, A. spacecraft

ASTRO-ELECTRONICS DIVISION

Bacher, J. energy conversion
Bacher, J. spacecraft
Baron, A. environmental engineering
Brown, I. energy conversion
Brown, I. spacecraft
Derbert, H. spacecraft instrumentation
Derbert, H. television equipment
Durrani, S. space communications
Feryszka, M. communications systems
Goldfarb, S. spacecraft
Head, V. environmental engineering
Head, V. spacecraft
Hollander, M. documentation
Keohane, E. spacecraft instrumentation
Keohane, E. television equipment
Rusta, D. energy conversion
Rusta, D. spacecraft
Schubert, B. spacecraft instrumentation
Schubert, B. television equipment
Staras, H. space communication

BROADCAST & COMMUNICATIONS PRODUCTS DIVISION

Brown, D. A. antennas
Forbes, E. J. television receivers
Harmon, R. N. television broadcasting
Hogge, C. R. communications systems
Hurst, R. N. circuits, integrated
Hurst, R. N. radio broadcasting
Kamerer, G. R. radio receivers
Siukola, M. S. antennas
West, J. R. recording image
West, J. R. television broadcasting
Winn, R. E. television broadcasting

CENTRAL ENGINEERING

Canale, S. human factors
Ingraham, H. S. standardization
Morris, F. H. circuits, packaged
Morris, F. H. management
Tiger, B. human factors
Tiger, B. reliability
Troxel, D. I. circuits, integrated
Troxel, D. I. reliability

COMMUNICATION SYSTEMS DIVISION

Acompora, A. electromagnetic waves
Aiello, R. L. circuit analysis
Bossard, B. B. communications components
Bradbard, E. M. communication, digital
Cattrell, A. G. reliability
Connor, W. J. space communication
Fields, C. W. documentation
Goldman, H. spacecraft instrumentation
Hortshorne, F. A. spacecraft
Hoger, D. T. management
Krell, A. reliability
Levine, P. communications components
MacDermid, B. W. communications components
MacDermid, B. W. space communication
Markard, E. communications components
Newton, A. electromagnetic waves
Paris, A. A. circuits, integrated
Rose, H. E. linguistics
Snell, H. education
Stahl, P. spacecraft instrumentation
Wolf, S. radio receivers

ELECTRONIC COMPONENTS & DEVICES

Ahrons, R. W. solid-state devices
Alina, W. reliability
Berson, B. E. communications components
Berson, B. E. solid-state devices
Berlin, E. P. laboratory techniques
Blicher, A. particle beams
Buckley, E. reliability
Cope, A. D. television equipment
D'Agostino, M. V. circuits, integrated
Hose, P. A. environmental engineering
Keller, J. P. circuits, integrated
Kuno, H. J. solid-state devices
Luedicke, A. D. television equipment
Murray, L. A. environmental engineering
Narayan, S. Y. communications components
Narayan, S. Y. solid-state devices
Schindler, H. C. superconductivity
Schrader, E. R. superconductivity
Sommer, A. H. properties, optical
Sondermeyer, J. C. reliability
Sterzer, F. solid-state devices
Sun, C. communications components
Sun, C. solid-state devices
Rivera, J. J. environmental engineering

MEDICAL ELECTRONICS DIVISION

Flory, L. E. medical electronics
Hatke, F. L. medical electronics

MISSILE & SURFACE RADAR DIVISION

Christensen, J. L. communications systems
Farnett, E. C. communications systems
Howard, T. B. communications systems
Mitchell, R. D. management
Profera, C. E. transmission lines
Pschunder, R. mechanical devices

NATIONAL BROADCASTING COMPANY

Bertero, P. television broadcasting
Wilson, J. L. television broadcasting

RCA LABORATORIES

Beelitz, H. R. circuits, integrated
Beelitz, H. R. computer systems
Belar, H. acoustics
Belar, H. linguistics
Bloom, S. particle beams
Bosonworth, D. R. superconductivity
Carnes, J. E. properties, molecular
Cheng, K. D. properties, chemical
Cody, G. D. superconductivity
Cohen, R. W. superconductivity
Cornely, R. H. lasers
Cosentino, L. S. computer storage
Cosentino, L. S. superconductivity
Coutts, M. D. properties, surface
Cullen, C. W. superconductivity
Gange, R. A. superconductivity
Gibson, J. J. circuits, integrated
Goldsmith, G. J. plasma physics

Goodman, A. M. properties, molecular
Gordon, I. computer storage
Gordon, I. properties, magnetic
Gorog, I. displays
Gorog, I. lasers
Goydsh, B. L. properties, chemical
Hahn, A. E. lasers
Hahn, A. E. solid-state devices
Holloran, J. J. superconductivity
Harvey, R. L. computer storage
Harvey, R. L. properties, magnetic
Hegji, I. J. lasers
Heiman, F. P. solid-state devices
Herzog, G. B. circuits, integrated
Herzog, G. B. computer systems
Hirota, R. electromagnetic waves
Kaldis, E. properties, chemical
Keneman, S. A. computer storage
Keneman, S. A. superconductivity
Kosonocky, W. F. lasers
Krausbauer, L. properties, chemical
Kressel, H. properties, molecular
Kressel, H. lasers
Kudman, I. properties, molecular
Lerner, S. properties, molecular
Levin, E. R. properties, surface
Linhardt, R. J. circuits, integrated
Linhardt, R. J. computer systems
Matzelle, A. lasers
Matzelle, A. solid-state devices
Meray-Horvath, L. recording, image
Meray-Horvath, L. solid-state devices
Meyer, J. E. recording, image
Meyer, J. E. solid-state devices
Müller, H. S. circuits, integrated
Müller, H. S. computer systems
Nagle, E. M. computer storage
Nagle, E. M. superconductivity
Nelson, H. lasers
Nelson, T. J. properties, optical
Nicoll, F. H. lasers
Olson, H. F. acoustics
Olson, H. F. linguistics
Pankove, J. I. lasers
Pankove, J. I. solid-state devices
Petzinger, K. G. lasers
Petzinger, K. G. solid-state devices
Pike, W. S. recording
Pike, W. S. solid-state devices
Pruss, T. V. properties, molecular
Rass, A. R. superconductivity
Robbi, A. D. computer storage
Robbi, A. D. properties magnetic
Rogers, E. S. linguistics
Rogers, E. S. acoustics
Ross, D. L. laboratory techniques
Ross, D. L. optics
Ross, P. W. linguistics
Sadasi, G. recording, image
Sadasi, G. solid-state devices
Saham, P. R. properties, molecular
Sass, A. R. computer storage
Sass, A. R. superconductivity
Schnitzler, P. properties, surface
Seidel, T. E. properties, molecular
Southgate, P. D. lasers
Sprong, F. W. displays
Sprong, F. W. lasers
Stander, R. solid-state devices
Stewart, W. C. computer storage
Stewart, W. C. superconductivity
Suzuki, K. electromagnetic waves
Taylor, B. N. superconductivity
Vural, B. particle beams
Warfield, G. properties, optical
Weimer, P. K. recording, image
Weimer, P. K. solid-state devices
Weisberg, L. R. properties, surface
Werner, R. E. laboratory techniques
Werner, R. E. recording, audio
White, J. G. properties, molecular
Widmer, R. properties, chemical
Williams, R. properties, chemical
Williams, R. properties, electrical
Williams, R. properties, surface
Williams, R. properties, atomic
Witke, J. P. properties, chemical
Woodward, J. G. laboratory techniques
Woodward, J. G. recording, audio
Woolston, J. R. laboratory techniques
Yacom, P. N. properties, molecular

RCA SERVICE COMPANY

Chew, V. mathematics

RCA VICTOR COMPANY, LTD.

Brown, T. communications components
Brown, T. space communication
Harrison, R. G. circuit analysis
Harrison, R. G. communications components
Kador, G. communications components
Kador, G. space communication
Koch, G. communication components
Koch, G. space communication
Miedzinski, J. education

RCA VICTOR RECORD DIVISION

Moyer, R. C. standardization

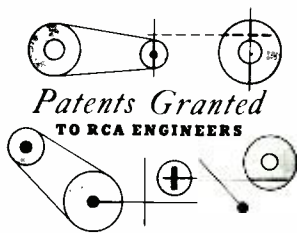

AS REPORTED BY RCA DOMESTIC PATENTS, PRINCETON HOME INSTRUMENTS DIVISION

Tone Arm Latching Device—D. E. Laux (HI, Indpls) U.S. Pat. 3,356,373, December 5, 1967
Suspension System for Stereophonic Pickups—J. A. Tourtellot, R. P. Peterson (HI, Indpls) U.S. Pat. 3,356,374, December 5, 1967
Temperature Compensated Transistor Blocking Oscillator—C. Liu, J. H. Nevin (HI, Indpls) U.S. Pat. 3,360,742, December 26, 1967
Magnetic Recording and Reproducing Apparatus—D. R. Andrews (HI, CH) U.S. Pat. 3,364,765, January 23, 1968
Electron Beam Deflection Circuit—G. L. Grundmann, J. J. Serafini (HI, Indpls) U.S. Pat. 3,365,608, January 23, 1968

ELECTRONIC COMPONENTS AND DEVICES

Method of Decreasing the Minority Carrier Lifetime by Diffusion—T. J. Desmond, L. S. Greenberg, H. Weisberg (ECD, MnTp) U.S. Pat. 3,356,543, December 5, 1967

Process for Preparing Yttrium Vanadate Phosphors—J. S. Martin, Jr., S. S. Trond (ECD, Lanc) U.S. Pat. 3,360,480, December 26, 1967

Thin Film Resistor Composed of Chromium and Vanadium—W. M. Triggs (ECD, Som) U.S. Pat. 3,360,688, December 26, 1967

Five-Layer Symmetrical Semiconductor Switch—J. M. S. Neilson, T. J. Desmond, H. Weisberg (ECD, MnTp) U.S. Pat. 3,360,696, December 26, 1967

Tubular Cell Anode for Sputter Ion Pumps—W. G. Henderson (ECD, Lanc) U.S. Pat. 3,364,370, January 16, 1968

Cathode Ray Tube with Mosaic Type Phosphor Screen—A. M. Morrell, R. H. Godfrey (ECD, Lanc) U.S. Pat. 3,358,175, December 12, 1967

Method of Salvaging Phosphor Slurry in a Spin Coating Process for Making Phosphor Screens for Cathode Ray Tubes—M. R. Weingarten (ECD, Lanc) U.S. Pat. 3,364,054, January 16, 1968

BROADCAST AND COMMUNICATIONS PRODUCTS DIVISION

Wide Band Transistor Video Signal Amplifier—B. S. Vilkomerson (BCD, Cam) U.S. Pat. 3,356,959, December 5, 1967

Cathode Arrangement of an Electron Microscope for Reducing the Occurrence of Virtual Cathodes—J. W. Coleman, J. J. Schuler (BCD, Cam) U.S. Pat. 3,363,961, January 16, 1968

RCA LABORATORIES

Memory Circuit Using Charge Storage Diodes—M. M. Kaufman (Labs, Pr) U.S. Pat. 3,356,998, December 5, 1967

Printer Having Print Bars with Zigzag Struts Out of Phase—M. Artzt (Labs, Pr) U.S. Pat. 3,357,533, December 12, 1967

Toner Feed Cartridge—R. R. Uлары (Labs, Pr) U.S. Pat. 3,360,111, December 26, 1967

Electrostatic Method of Making Multiple Copies of an Image—R. G. Olden (Labs, Pr) U.S. Pat. 3,363,555, January 16, 1968

Cryotron Circuits—R. W. Ahrons (Labs, Pr) U.S. Pat. 3,364,364, January 16, 1968

Combined Thermoelectric Operator and Storage Battery Operation—N. E. Lindenblad (Labs, Pr) U.S. Pat. 3,355,652, November 28, 1967 (Patent assigned to U.S. Government)

COMMUNICATIONS SYSTEMS DIVISION

Frequency Multipliers Utilizing Self-Resonant Diode Mounts—A. Schwarzmann (CSD, Cam) U.S. Pat. 3,358,214, December 12, 1967

ADVANCED TECHNOLOGY

Switching System—W. J. Hannan (AT, Cam) U.S. Pat. 3,359,375, December 19, 1967

Light Emitter Controlled by Bi-Stable Semiconductor Switch—G. K. Zin (AT, Cam) U.S. Pat. 3,364,388, January 16, 1968

AEROSPACE SYSTEMS DIVISION

Bistable Circuit with Negative Resistance Diode—W. A. Miller, J. Y. Robertson (ASD, Cam) U.S. Pat. 3,359,427

Coaxial Diode Cartridge—O. J. Hanas, R. D. Alaburda (ASD, New Castle) U.S. Pat. 3,351,842, November 7, 1967 (Patent assigned to U.S. Government)

RCA COMMUNICATIONS, INC.

Frequency Correction System—R. Konian (RCA Com. N.Y.) U.S. Pat. 3,361,976, January 2, 1968

ELECTRONIC DATA PROCESSING

Position Indicating Apparatus—U. Germen (EDP, W. Palm Bch) U.S. Pat. 3,365,568, January 23, 1968

DEFENSE MICROELECTRONICS ENGINEERING

LSI Array and Standard Cells—T. R. Mayhew (DME, Cam) U.S. Pat. 3,365,707, January 23, 1968

RCA CONSULTANTS

Portable Television Receiver—D. Chapman, M. Polhemus (RCA, Chicago) U.S. Pat. D209,779

Meetings

MARCH 18-21, 1968: IEEE International Convention & Exhibition, IEEE, Coliseum & N.Y. Hilton Hotel, New York, N.Y. Prog info: J. M. Kinn, IEEE, 345 E. 47th St., New York, N.Y.

MARCH 25-26, 1968: Princeton Conf. on Information Science & Systems, G-CT, Princeton University, Princeton Univ., Princeton, N.J. Prog info: IEEE Headquarters, 345 E. 47th St., New York, N.Y.

APRIL 3-5, 1968: Int'l Magnetics Conference (INTERMAG), G-MAG, Sheraton Park Hotel, Washington, D.C. Prog info: J. M. Lommel, Gen'l Elec. Res. & Dev. Ctr., P.O. Box 8, Schenectady, N.Y. 12301

APRIL 9-11, 1968: National Telemetering Conference, G-AES, G-ComTech, Shamrock Hilton Hotel, Houston, Texas. Prog info: R. J. W. Koopman, Washington Univ., St. Louis, Missouri 63130

APRIL 17-19, 1968: Southwestern IEEE Conf. & Exhibition (SWIEECO), Region 5, Houston Conv. & Exh. Ctr., Sheraton Lincoln Hotel, Houston, Texas. Prog info: J. V. Leeds, Jr., Rice Univ., P.O. Box 1892, Houston, Texas 77001

APRIL 22-24, 1968: Interference Problems Associated with the Operation of Microwave Comm. Systems, U.K. & Republic of Ireland Section, London, England. Prog info: IEEE Headquarters, 345 E. 47th St., New York, N.Y.

APRIL 23-24, 1968: Electrical Power Processes Conference, G-ED, G-AES, Mass. Inst. of Technology, Cambridge, Mass. Prog info: IEEE Headquarters, 345 E. 47th St., New York, N.Y.

APRIL 23-26, 1968: Cybernetics Conference, German Sec. of IEEE, DGK, NTG, Munich, F.R., Germany. Prog info: H. H. Burghoff, 6 Frankfurt/Main 70, F.R. Germany, Stresemann Allee 21, VDE Haus

APRIL 30-MAY 2, 1968: Spring Joint Computer Conference, G-C, AFIPS, Convention Hall, Atlantic City, New Jersey. Prog info: T. R. Bashkow, Columbia Univ., 1312 S.W. Mudd, New York, N.Y. 10027

MAY 5-10, 1968: 103rd Technical Conference of the Society of Motion Picture and Television Engineers, Plaza Hotel, Los Angeles. Prog info: Warren Strang, Hollywood Film Co., 956 N. Seward St., Hollywood, Calif. 90038

MAY 6-7, 1968: Human Factors in Electronics Symposium, G-MMS, Marriott Twin Bridges Motor Hotel, Washington, D.C. Prog info: H. P. Birmingham, U.S. Naval Res. Lab., Code 5120, Washington, D.C. 20390

PROFESSIONAL MEETINGS DATES AND DEADLINES

Be sure deadlines are met—consult your Technical Publications Administrator or your Editorial Representative for the lead time necessary to obtain RCA approvals (and government approvals, if applicable). Remember, abstracts and manuscripts must be so approved BEFORE sending them to the meeting committee.

MAY 6-8, 1968: Aerospace Electronics Conference (NAECON), G-AES, Dayton Section, Dayton, Ohio. Prog info: IEEE Dayton Office, 124 E. Monument Ave., Dayton, Ohio

MAY 6-8, 1968: Packaging Industry Tech. Conference, G-IGA, Pheasant Run Lodge, St. Charles, Illinois. Prog info: IEEE Headquarters, 345 E. 47th St., New York, N.Y.

MAY 8-10, 1968: Electronic Components Conference, G-PMP, EIA, Marriott Twin Bridges Motor Hotel, Washington, D.C. Prog info: F. M. Collins, Speer Res. Lab., Packard Rd. & 47th St., Niagara Falls, N.Y. 14302

MAY 23, 1968: Vehicular Communications Systems Symposium, G-VT, Int'l Hotel Los Angeles, Calif. Prog info: C. R. Lindholm, Rand Corp., 1700 Main St., Santa Monica, Calif. 90406

JUNE 20-22, 1968: IFAC Symposium on Optimal Systems Planning, G-SSC, IFAC, Case Inst. of Tech., Cleveland, Ohio. Prog info: L. F. Kirchmayer, Gen'l Elec. Co., Schenectady, N.Y. 12305

JUNE 25-28, 1968: Precision Electromagnetic Measurements Conference, G-IM, NBS, URSI, Nat'l Bureau of Standards, Boulder, Colorado. Prog info: D. D. King, Philips Labs., 345 Scarborough Rd., Briarcliff Manor, N.Y.

JUNE 26-28, 1968: Joint Automatic Control Conference, G-AC, AACC, Univ. of Mich., Ann Arbor, Mich. Prog info: Michael Athans, Dept. of EE, MIT, Cambridge, Mass.

Calls For Papers

MAY 14-17, 1968: Int'l Quantum Electronics Conference, G-ED, G-MTT, JCQE, AIP, Everglades Hotel, Miami, Florida. Deadline info: 1/8/68 (sum) to: R. W. Terhune, Ford Motor Co., Detroit, Michigan.

MAY 20-22, 1968: International Microwave Symposium, G-MTT, Howard Johnson Motor Lodge, Detroit, Michigan. Deadline info: 1/8/68 (sum & abst) to: G. I. Haddad, Univ. of Mich., Dept. of EE, Ann Arbor, Mich.

JUNE 12-14, 1968: Int'l Communications Conference, G-ComTech, Philadelphia Section, Sheraton Hotel, Univ. of Penna., Phila., Pa. Deadline info: 1/15/68 (papers) to: R. S. Caruthers, IT & T Corp., 320 Park Ave., New York, N.Y. 10022

JUNE 23-28, 1968: Summer Power Meeting, Sherman House, Chicago, Illinois, G-P. Deadline info: 2/9/68 (papers) to: IEEE Headquarters, 345 E. 47th St., New York, N.Y.

JUNE 25-27, 1968: Computer Conference, G-C, Int'l Hotel, Los Angeles, Calif. Deadline info: 1/15/68 (papers) to: Harold Peterse, Rand Corp., 1700 Main St., Santa Monica, Calif.

JUNE 25-28, 1968: Conf. of Precision Electromagnetic Measurements, Boulder, Colorado. Deadline info: 2/12/68 (abst & sum) to: Donald D. King, Aerospace Corporation, P.O. Box 95085, Los Angeles, Calif.

JULY 15-18, 1968: Nuclear & Space Radiation Effects Conference, G-NS, Univ. of Montana, Missoula, Montana. Deadline info: 3/1/68 (summary) to: R. S. Caldwell, 23-72, Radiation Effects Lab., Boeing Co., P.O. Box 3707, Seattle, Wash.

AUG. 13-16, 1968: Intersociety Energy Conversion Engineering Conference, IEEE et al, Univ. of Colorado, Boulder, Colorado. Deadline info: 1/15/68 (abst) to: D. B. Dobson, RCA, P.O. Box 588, Burlington, Mass. 01801

AUG. 27-29, 1968: ACM National Conference and Exposition, Las Vegas, Nevada. Prog info: Marvin W. Ehlers Program Committee Chairman, Ehlers, Maremont & Co., 57 W. Grand Ave., Chicago, Illinois. Deadline info: 3/1/68 (papers) to: Marvin W. Ehlers

SEPT. 29-OCT. 3, 1968: IGA Group Annual Meeting, G-IGA, La Salle Hotel, Chicago, Illinois. Deadline info: 3/1/68 (abst) to: R. W. Mills, Rel. Elec. Engineering Co., 24701 Euclid Ave., Cleveland, Ohio

JAN. 26-31, 1969: Winter Power Meeting, G-P, Statler Hilton Hotel, New York, N.Y. Deadline info: 9/13/68 (papers) to: IEEE Headquarters, 345 E. 47th St., New York, N.Y.

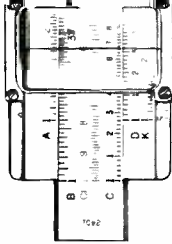

H. R. WEGE RETIRES AFTER 43-YEAR CAREER



Harry Wege was one of the early authors (Vol. 2, No. 4) in the RCA ENGINEER and engineers of his division were responsible for supporting two complete issues.

Harry R. Wege recently retired from RCA, culminating a 43-year career in the electronics industry. From wireless to radio and radar, missile guidance, and the mammoth defense systems of today, Harry Wege has stayed in the forefront of technology since he left the campus of Kansas State University in 1925. His engineering skills, his organizational talents, and leadership qualities made him grow from test apprentice to corporate vice-president.

Harry Wege built an engineering team which was always in the forefront of the radar field, resulting in the establishment of the RCA Moorestown Plant in 1953. Harry has received many honors for his technical accomplishments and civic contributions during his long career.

Thursday evening, January 25, 1968, over 350 of his associates and friends gathered to

honor him at a retirement testimonial dinner at Kenney's Suburban House.

Honored that same day by a citation from the Moorestown Rotary Club, he received a special memorial plaque from the Burlington County Boy Scouts and letters of appreciation from Brig. General David Sarnoff, Dr. Elmer Engstrom, and Robert W. Sarnoff. Charles L. Walton, Mayor of Moorestown, presented a resolution passed by the Township Council, and State Senator President, Edwin B. Forsythe read a letter of appreciation from Governor Richard B. Hughes. Harry Wege was also given a special "Asparagus in Blacktop" award and a complete set of golfing equipment from his many friends.

Some of the milestones in Harry Wege's outstanding career are:

- 1925-1929 Test Engineer and Radio Design Engineer, General Electric Company
- 1929-1939 Special Radio Receiver Design Group, RCA Victor
- 1940 Supervisor, Radar Engineering Group
- 1952 Chief Engineer, Missile and Surface Radar Engineering
- 1956 General Manager, Missile and Surface Radar Division
- 1959 Vice President and General Manager, Missile and Surface Radar Division
- 1961 Vice President and General Manager, Data Systems Division, DEP
- 1963 Vice President, RCA and Director SAM-D Program

A. L. CONRAD NAMED TO IEEE ADVISORY COMMITTEE

A. L. Conrad, President, RCA Service Company, has been appointed to the Executive Advisory Committee for the Seventh Annual IEEE Region III Convention. Conrad will advise IEEE officials in planning and directing convention activities.

This year, the convention will be held in Cocoa Beach, Florida, Nov. 18-20 and is being sponsored by the Kennedy Section of the IEEE. A wide range of scientific and engineering disciplines will be served during the three-day event. Sessions will cover antennas, power, telemetry, microelectronics, education, telephone, space electronics, computers, oceanography, holography, and new tools of mathematics.

Theme of the convention is "Knowledge, Key to the Future." The latest in test equipment, display devices, controls and related electronic hardware will be exhibited. Information on exhibits may be obtained by contacting: L. B. Perkins, IBM, 8600 N. Astronaut Blvd., Cape Kennedy, Florida 32920.

Call for Papers

Technical papers dealing with extra-high voltages, solid-state load control, system protection, and other related subjects are now being accepted.

Three copies of the full paper and three copies of an abstract (not exceeding 100 words) should be submitted to: Technical Papers Chairman, LaVergne E. Williams, Aerospace Corporation, P.O. Box 4007, Patrick Air Force Base, Florida 32925. Papers should be delivered to the chairman on or before June 1, 1968.

Authors will be notified on or before July 15, 1968 of acceptance, and will be provided with an author's guide and model paper kits for preparing the final manuscript. Deadline for final papers is Sept. 1, 1968.

A tutorial seminar on "Integrated Circuits and Their Incorporation in Equipment" is being offered as part of the convention program.

LICENSED ENGINEERS

- L. C. Drew, DEP-ASD, PE-21640, Mass.
- J. S. J. Harrison, DEP-ASD, PE-21663, Mass.
- H. S. Tiger, DEP-ASD, PE-21627, Mass.
- G. J. Rogers, DEP-MSR, PE-15073, N.J.
- M. Jarvis, AED, PE-15586, N.J.

MARCH IEEE PLANNED

The technical program has been announced for the 1968 IEEE International Convention, the world's largest technical meeting of electrical and electronics engineers. The program will consist of more than 50 technical sessions scheduled over a four-day period from March 18 through March 21. More than 200 papers are offered. All sessions will be held in New York City at both the New York Coliseum and the New York Hilton for the full four days. Papers for the program were selected by the Technical Program Committee under the chairmanship of Dr. E. W. Herold, RCA, Princeton, New Jersey. A Chart of the Sessions and a Preliminary Schedule of Events for the 1968 IEEE International Convention and Exhibition has just been released.

SCHNAPF HONORED WITH ASQC RELIABILITY AWARD FOR WORK ON TIROS WEATHER SATELLITE SERIES

Abraham Schnapf, Manager of the TIROS and TIROS Operational system (Tos) Satellite programs for the Astro-Electronic Division, Princeton, N.J., received the 1967-68 Reliability Award from the American Society for Quality Control.

Mr. Schnapf has been responsible for management of design and fabrication of the ten TIROS and six Tos/ESSA weather satellites, all of which have met or exceeded their mission goals. The program which is under technical direction of NASA's Goddard Space Flight Center, is the world's first global operational satellite system.

The 1968 IEEE International Convention—a week at a glance

Day	Exhibition	Technical Sessions	Tutorial Sessions	Workshop: How To Present A Technical Talk	Special Microwave Presentations	Film Theater* Compressed Speech**	Cocktail Party
Monday March 18	N.Y. Coliseum 10:00 A.M. to 8:00 P.M.	N.Y. Hilton 10:00 A.M. to 12:30 P.M. 2:00 P.M. to 4:30 P.M.	N.Y. Hilton East & West Ballrooms Special Reg. 8:00 A.M. to 10:00 A.M.	N.Y. Hilton Sutton South 8:30 A.M. to 10:00 A.M.	N.Y. Coliseum Microwave Hall (So. America Rm) 10:30 A.M. to 5:00 P.M.	N.Y. Coliseum United Nations Room 10:30 A.M. to 8:00 P.M.	N.Y. Hilton East Ballroom 5:30 P.M. to 7:30 P.M. Spec. Highlight Eve. Symposium N.Y. Hilton Grand Ballroom 8:00 P.M.
Tuesday March 19							Convention Banquet
Wednesday March 20				Organized by the Group on Engineering Writing & Speech	Organized by the Group on Microwave Theory and Techniques	*Organized by the Group on Education **Organized by the Group on Engineering Writing & Speech	8:00 P.M.
Thursday March 21							N.Y. Hilton Grand Ballroom 7:15 P.M.

OTHER EVENTS — While many of these meetings are not officially connected with the Convention, they are included here should you wish to include them in your plans. The majority are by special registration or invitation and attendance is limited.

STAFF ANNOUNCEMENTS

By action of the Board of Directors of Radio Corporation of America, **Mr. Chase Morsey, Jr.**, has been elected a Vice President of the Corporation, Marketing, and will be responsible for all marketing activities.

M. E. Karns, Vice President, Patents and Licensing, has announced the appointment of **J. V. Regan**, Staff Vice President, Patent Operations, Research and Engineering.

L. S. Nergaard, Director, Microwave Research Laboratory, appointed **B. Hershenov**, Head, Microwave Integrated Circuits, Microwave Research Laboratory, Research and Engineering.

I. K. Kessler, Division Vice President, Defense Electronic Products, has announced the transfer of Micro-Circuit Manufacturing Operations to Missile and Surface Radar Division. **F. J. Drakeman** will continue as Manager, Microwave Circuit Manufacturing Operations, reporting to **J. H. Sidebottom**, Division Vice President and General Manager, Missile and Surface Radar Division.

D. Shore, Chief Defense Engineer, Defense Engineering, Defense Electronic Products, announced that **S. Rosenberg** will be Manager, Defense Microelectronics, reporting to the Chief Defense Engineer.

J. B. Farese, Executive Vice President, Electronic Components and Devices, has appointed **G. W. Duckworth** to a newly created position, Division Vice President, Equipment Sales. In this capacity, Mr. Duckworth will have the sales responsibility for all RCA Electronic Components and Devices domestic products, except those which are sold through distributor channels.

G. W. Duckworth, Division Vice President, Equipment Sales, Electronic Components and Devices, announced the organization of Equipment Sales as follows: **W. A. Glaser**, Manager, Equipment Sales, **T. R. Hays**, Manager, Special Accounts, **G. J. Janoff**, Manager, Commercial Policies and Controls, **R. B. Means**, Manager, Interdivisional Sales, **G. W. Duckworth**, Acting Manager, Government Sales and Market Coordination.

C. E. Burnett, Division Vice President and General Manager, Solid State and Receiving Tube Division, Electronic Components and Devices, announced the organization of Solid State and Receiving Tube Division as follows: **H. A. DeMooy**, Manager, Receiving Tube Operations Department, **D. J. Donahue**, Manager, Solid State Operations Department, **N. H. Green**, Manager, Solid State and Receiving Tube Planning, **B. A. Jacoby**, Manager, Market Planning—Solid State Signal Devices, **J. W. Karoly**, Manager, Financial Controls, **D. R. Ozsvath**, Manager, Market Planning—Receiving, and **J. P. McCarthy**, Manager, Market Planning—Solid State Power Devices.

E. Rudolph, Manager, Equipment Design and Development, Receiving Tube Operations Department, Solid State and Receiving Tube Division, Electronic Components and Devices, announced the organization of Equipment Design and Development as follows: **M. M. Bell**, Manager, Mechanical and Electrical Equipment Design, **W. T. Ackermann**, Manager, Mechanical Equipment Design, **A. D. Checki**, Manager, Mechanical Equipment Design, **S. N. Nasto**, Manager, Electrical Equipment Design, **R. J. Hanlon**, Manager, Equipment Development Shops, **H. Hermann**, Manager, Equipment Development Resident Engineering—Cincinnati, and **G. A. Santulli**, Manager, Technical Services.

H. P. Lemaire, Manager, Memory Products Engineering, Memory Products Division, Electronic Components and Devices,

announced the organization of Memory Products Engineering as follows: **B. Frackiewicz**, Manager, Test Equipment Development, **B. P. Kane**, Manager, Memory Systems Engineering, **A. C. Knowles**, Manager, Applications Engineering, **P. D. Lawrence**, Manager, Device Electrical Engineering, **C. H. McCarthy**, Administrator, Engineering Administration, **E. A. Schwabe**, Manager, Mechanical Device and Core Engineering, and **L. A. Wood**, Manager, Engineering Services.

J. R. Bradburn, Executive Vice President, Information Systems, announced the organization of Information Systems, Electronic Data Processing follows: **A. D. Beard**, Chief Engineer, Engineering, **A. W. Carroll**, Manager, Systems Programming, **A. G. Daubert**, Manager, Product Assurance, **H. W. Johnson**, Division Vice President, Field Engineering (formerly designated as EDP Service), **H. H. Jones**, Controller, Finance, **E. S. McCollister**, Division Vice President, Marketing, **N. R. Miller**, Division Vice President, Business and Economic Planning, **M. J. Shuman**, Manager, Personnel, and **K. L. Snover**, Manager, Manufacturing Operations. **S. W. Cochran** will continue as Division Vice President and General Manager, Graphic Systems Division.

A. D. Beard, Chief Engineer, Engineering, Electronic Data Processing, Information Systems, announced the appointment of **H. J. Martell**, Manager, Engineering and Manufacturing Operations at the newly established facility, Marlboro, Mass. Until the Marlboro facility is completed, this facility is located at Framingham, Mass.



JESS EPSTEIN ON RESEARCH AND ENGINEERING STAFF

Appointment of **Jess Epstein** as Staff Engineer, Research and Engineering, was announced by **Dr. George H. Brown**, Executive Vice President, RCA Research and Engineering.

Mr. Epstein, who has been with RCA since 1935, is a specialist in electromagnetic propagation and radiating systems. Before his appointment, he had been with the RCA Missile and Surface Radar Division in Moorestown, N.J.

Mr. Epstein attended the University of Cincinnati, receiving the Electrical Engineering degree in 1932 and the Master of Science degree in Physics in 1934. He joined the RCA Manufacturing Co. in Camden, N. J., in 1935, and in 1942 transferred to RCA Laboratories when it was established in Princeton. Mr. Epstein remained with RCA Laboratories until 1961 when he joined the Antenna Skill Center at the RCA Missile and Surface Radar Division. A Senior Member of the Institute of Electrical and Electronics Engineers, and a Member of Sigma Xi, Mr. Epstein is listed in "Who's Who in Engineering."

... PROMOTIONS ...

to Engineering Leader & Manager

As reported by your Personnel Activity during the past two months. Location and new supervisor appear in parentheses.

Communications Systems Division

R. Barone: from Proj. Engr. to Ldr. Engr., Heavy Communications Equipment Engr. (W. J. Connor, Camden)

Astro-Electronics Division

E. F. Begg: from Ldr., Proj. Adm. to Mgr., Proj. Oper. Cont. (D. Hartmann, Princeton)

R. C. Curry: from Engr. to Ldr., Engrs. (S. Gubin, Princeton)

F. Gleason: from Engr. to Ldr., Engrs. (R. Packer, Princeton)

M. Holman: from Engr. Sr. to Ldr., Engrs. (E. Walthall, Princeton)

H. P. Howard: from Sr. Engr. to Mgr., Qual. Assur. Engr. (H. Wuerfel, Princeton)

F. Seacore: from Engr. to Ldr. Engrs. (M. Shepetin, Princeton)

Missile and Surface Radar Division

J. A. Colligan: from Ldr., Eng. Sys. to Mgr., TRADEX Site (F. H. Tillwick, Moorestown)

Aerospace Systems Division

E. Kornstein: from Ldr., T.S. to Mgr., Optical Physics Techniques (P. Seeley, Burlington)

F. C. Hasset: from Engr. Scientist to Ldr., T.S. (D. Cushing, Burlington)

Electronic Components and Devices Division

F. T. D'Augustine: from Engr. to Ldr. Equip. Dev. (M. R. Weingarten, Lancaster)

G. Novak: from Engr. Ldr. to Mgr., Traveling Wave Tube Production Engr. (H. Learner, Harrison)

Broadcast and Communications Division

R. W. Voekler: from "A" Engr. to Ldr. Des. & Dev. Engrs. (A. H. Lind, Camden)

Electronic Data Processing

A. R. Laliberte: from "A" Engr. to Ldr., Des. & Dev. Engrs. (B. I. Kessler, Camden)

P. M. Woolley: from Ldr., T.S. to Mgr., Product Engr. (H. N. Morris, West Palm)

S. M. Tucker: from Staff Engr. Scientist to Mgr., Communications & Spec. Sys. Des. Engr. (H. N. Morris, West Palm)

RCA Service Company

W. G. Fields: from Engr. to Mgr., Communication & Telemetry (M. J. Van Brunt, Florida)

J. A. Rehwinkel: from Engr. to Ldr., Engrs. (K. J. Starzinger, Florida)

K. W. Hargus: from Engr. to Ldr., Engrs. (O. E. Cole, Kwajalein)

J. O. Cain: from Engr. to Ldr., Engrs. (K. J. Starzinger, Florida)

M. W. Stinson: from Ldr., Engrs. to Mgr., CW Radar Engr. (G. B. Cope, Florida)

S. D. Redford: from Engr. to Mgr., Navigation Data Handling Shipboard (M. J. Van Brunt, Florida)

Graphic Systems Division

G. W. Maymon: from Engr. to Ldr., T.S. (D. Meredith, Princeton)

P. E. Justus: from Engr. to Ldr., T.S. (D. Meredith, Princeton)

PROFESSIONAL ACTIVITIES

*Aerospace Systems Division,
Burlington, Mass.*

A. W. DiMarzio, Chapter Chairman of the IEEE Electromagnetic Compatibility and Aerospace Electronic Systems Joint Group, was host at a Boston Chapter meeting. The meeting was held on November 28, 1967, at ASD Burlington, an active contributor to all forms of science and engineering.

J. R. McAllister established an Advanced Technology Planning Council, effective January 1, which will meet at least monthly. Committee members are: **E. J. Dieterich**, **N. L. Laschever**, and **P. E. Seeley**. The Committee will provide technical guidance on IR&D programs, five-year technical plans, technical liaison with other RCA Divisions and Laboratories and comparable industrial sources, agencies and laboratories of the Federal Government and appropriate educational institutions. **R. K. Saxe** will serve as Secretary for the Committee.

Wayne Martin served as co-chairman of the program committee for the IEEE Hybrid Microelectronic Circuits Lecture Series presented at M.I.T. in January. **Bernard Buckvar** was a member of the papers coordination committee, and **Phil Rossignol** gave a presentation on "Designing with Hybrid Microelectronic Circuits" during this lecture series.

Amy C. Spear has been named to "Who's Who in the East" and "Who's Who in Industry and Commerce" for the year 1968-69. —*D. B. Dobson*

Electronic Data Processing, Camden, N. J.

Dr. H. Sassenfeld, Manager, Control Systems, addressed attendees at an ACM professional development seminar in New York. His talk on the "Architecture of Time Sharing Hardware" was part of an 11-session lecture series presented by the ACM. —*G. D. Smoliar*

RCA Laboratories, Princeton, N. J.

Over 120 people attended the MOS field-effect-transistor seminar sponsored by the IEEE Princeton Section. Fifty different companies and organizations were represented. Following some opening remarks by **G. B. Herzog**, Chairman of the Princeton Section, **Dr. Fred Heiman** began the Seminar with a comprehensive treatment of the Physics of the MOSFET. **Dr. R. W. Ahrons** discussed linear circuit characteristics and applications. **Mr. J. Gibson** covered digital applications.

Dr. E. W. Herold, a charter member of the IEEE Princeton Section has been named chairman of the Technical Program Committee for the 1968 IEEE International Convention and Exhibition by **D. G. Fink**, General Chairman of the Convention. —*C. W. Sall*

Central Engineering, Camden, N. J.

J. L. Krager, Jr., Administrator, Military Packaging, was recently appointed to the Executive Board of the Packaging Division, American Ordnance Association (AOA).

H. R. Ketcham, Documentation and Configuration Management Specialist, recently received two key appointments to the Council of Defense and Space Industries Association (CODSIA) as follows: Co-Chairman, CODSIA Task Group concerned with the DOD's proposed specifications and standards dealing with configuration management; and Member, CODSIA Task Group concerned with the proposed U.S. Navy specification, AR-30, entitled "Integrated Logistic Support Program Management."

J. R. Hendrickson, Sr. has been listed in the new edition of "Who's Who in Atoms" and in "World's Who's Who in Science."

S. K. Magee, Manager, Project Administration and Services, has been appointed by AIA as electronics industry representative to the newly established Standardization Management Policy Group under its Aerospace Technical Council. This key policy group will provide AIA guidance to standardization management in the complete range of aerospace product standardization, both nationally and internationally, and with the Government.

J. W. Kaufman, Materials Laboratory, presented a lecture on "Non-Destructive Testing" as part of a continuing course entitled "Shop Practices Methods" sponsored by the Camden Training Activity of DEP.

A. Siegel, Parts Applications Activity, was moderator and a guest lecturer at a graduate seminar at Northeastern University, Boston, Mass. Mr. Siegel lectured on the subject "Electromechanical and Reed Relays from the User's Standpoint."

W. W. Thomas, Manager, Documentation Programs, and **J. A. Doughty**, Manager, Programs Development (CSD, Cam), delivered a joint presentation on "Transitioning R&D Work to Production" at the DOD Service R&D Transition Committee meeting held at the Pentagon, Wash., D.C.

S. Canale and **J. R. Hendrickson, Sr.** have been appointed delegates to the 1968 Engineering and Technical Societies Council of Delaware Valley, Inc., Phila., Pa., by the System Safety Society.

R. M. Walsh has been appointed 1968 liaison representative to RCA by the American Chemical Society. —*J. R. Hendrickson, Sr.*

Astro-Electronic Division, Princeton, N. J.

R. D. Wilkes has been appointed member Educational Council, MIT for a 3-year term.

M. Wolf has been selected for membership of NASA's newly established Research and Technology Advisory Committee on Space Power and Electric Propulsion. Mr. Wolf has also been appointed a member of convention committee of the IEEE 7th Photovoltaics Specialists Conference, 1968.

B. Shepherd has been named Chairman, Young Eng. Committee, Ocean County Society of Professional Engineers, and has also been made Alternate Trustee-Exec. of the same organization. —*S. Weisberger*

*Electronic Components and Devices,
Lancaster, Pa.*

J. M. Forman, P.E., Chairman of the Lancaster Vocational Technical Education Technology Craft Committee #1 was one of a group of five speakers at a Vo-Tech sponsored meeting for area guidance counsellors. Mr. Forman spoke on the subject "Technology" to approximately 95 Guidance Counsellors. Mr. Forman's subject related to entrance requirements, opportunities for employment, current and future objectives of the technology committee as it pertains to course development in three areas: Electronic Technology, Industrial Laboratory Technology, and Instrumentation Technology. A valuable question and answer discussion period was then provided by the five panelists.

Mr. J. T. Gote, P.E., of Special Equipment Engineering of the Electrical Measurements & Environmental Engineering Laboratory just completed teaching a 10-week graduate course entitled "Transistors in Active Circuits" at the Penn State Capital Campus Graduate Center in Middletown, Pa. —*J. M. Forman*

AWARDS

*Electronic Components and Devices,
Lancaster*

An IR100 Award was presented to RCA by Industrial Research, Inc. for the development of a family of long life gas lasers. The award was presented to RCA by Industrial Research, Inc. as one of the 100 most significant new technical products of the year. **Dr. James Hillier**, Vice President of RCA Laboratories, accepted the award on behalf of RCA. The developmental award centered around the achievement of both the complete development and production of a 100-milliwatt and a 1-watt argon gas laser system. The award team consisted of the following engineers: **Karl Hernquist** and **James Fendley** of the RCA Laboratories and **John Powell** and **Harry Medsger** of Development Engineering of the Super Power Devices Operations of RCA, Lancaster, Pa.

J. M. Forman

Astro-Electronic Division, Princeton, N. J.

H. Bilsky has been named Engineer of the Month for December at AED. —*S. Weisberger*

*Aerospace Systems Division,
Burlington, Mass.*

E. R. Brunckhorst has been named Engineer of the Month for August, and **M. William Stewich** has been named Engineer of the Month for September. —*D. Dobson*

*Missile and Surface Radar Division,
Moorestown, N. J.*

Thirteen M&SR engineering personnel received *cost breakthrough awards* for playing leading roles in devising lower cost designs or methods while improving technical excellence. They are cited by **D. M. Cottler**, Chief Engineer, as follows: **Y. H. Dong** for the design of a low-cost tower array to support antenna suspension cables on the FPS-95. **J. H. Duckett**, **L. W. Lazarick**, **A. J. Miller**, and **A. G. Onni** for devising a lower cost connector for the SPS-12 magnetron. **B. C. Stephens** and **A. Eintracht** (Graphic Systems Division) for the development of a simplified, lower-cost module for the 5-MHz selection circuitry associated with the generation of a coherent clock in the range tracking system.

The following citations represent significant cost savings on the Range Data Processor: **R. J. McCurdy** and **J. DiCicuccio** for the development and implementation of a digital integration technique which simplified and reduced the cost of the RDP system and improved its reliability and flexibility. **D. E. Whitfield**, **B. D. Gates**, and **R. Dawson** for reducing the cost of the RDP system through design simplification and producibility improvements. **R. Craft** for accomplishments in modifying the Automatic Target Acquisition logic design of the RDP system to include a new customer requirement of providing a synthetic video display output.

LIBRARIES TO RECEIVE IEEE CONFERENCE PUBLICATIONS UNDER NEW POLICY

Libraries and other technical book centers may now arrange to receive, automatically, as they are published, all new IEEE conference publications. These publications are now available on an *open-order-plan* which enables the purchaser to receive the publications automatically on a ship-and-bill basis. This new plan excludes preprints of conference papers and conference issues of Group Transactions. The IEEE is offering subscribers to this plan a ten percent discount off the list price they would normally pay. For further information write to: *IEEE Subscriber Order Unit, 345 East 47th Street, New York, New York (10017).*



CORPORATE-WIDE COMMUNICATIONS PROGRAM AFFECTS TRADEMARK, PRODUCTS, SERVICES AND FACILITIES

A new corporate-wide communications program for RCA, modernizing every facet of its appearance from trademark to office design and reflecting the company's growth and diversification, was announced by **Robert W. Sarnoff**, President and Chief Executive Officer.

"This broad program has been planned to convey the modern character of RCA as a diversified enterprise that has evolved over the past half century from a pioneering base in communications and electronics to leadership in total information technology," said Mr. Sarnoff.

"We are now intimately involved with every principal aspect of this technology, from broadcasting and publishing to computers and educational systems. The corporate-wide new look corresponds to this change, and it will be used to unify the identification of all RCA products, services, installations, and communications."

Work on the new communications program was initiated by Mr. Sarnoff when he took office as RCA's President on January 1, 1966. While the new concept will apply to all products and activities associated with RCA, the most notable and probably the earliest effect from the public viewpoint will be the appearance of the new RCA trademark. The new mark employs the three letters standing alone in a bold contemporary design to form a distinctive single unit. It replaces the 46-year-old design formed by the letters "RCA" underlined by a symbolic lightning flash and enclosed in a circle.

A comprehensive design system employing the new trademark and based on the new identification concept will be applied throughout the corporation, affecting all of its communications. Thus there will be a new look to:

- 1) Printed material for internal and external use, from RCA letterheads and product brochures to stock certificates and RCA Communications message blanks;
- 2) Product identifications, including the trademark and specific brand designations on RCA products, and the

graphic design of their packages;

- 3) Advertising for RCA products and services in all media;
- 4) Signs on the company's offices and plants and on the facilities of RCA distributors and dealers, and identifying designs on RCA trucks and other vehicles;
- 5) Uniforms and special work clothes worn by certain RCA personnel.

The change in style was introduced January 21 to the public in a corporate advertising campaign with nationwide television commercials. Advertisements featuring the new look appeared in the national edition of the *Wall Street Journal* and in selected newspapers across the nation. Double-page color spreads also appear in major national magazines, including *Time*, *Newsweek*, *Business Week*, *Forbes*, and *Fortune*.

Discussing the scope of RCA's new communications program, Mr. Sarnoff cited its use of "graphic planning to signify the many changes that have taken and are taking place within RCA because of the constant flow of new products, new facilities, new management, and new systems."

"The program has been designed to establish a consistency in style across the full spectrum of these activities and in all of RCA's markets," he said. "While there will be no rigid uniformity in visual identity of the various RCA goods and services, they will all share a family resemblance which enables the public to associate each element immediately and unmistakably with RCA."

In accordance with this concept, the program calls for consistent identification of all RCA products by the RCA name, standing either alone or in a dominant position over any special designations or brand names used on certain products, such as the SPECTRA 70 computers or the VIDEOCOMP electronic typewriter.

The new RCA corporate trademark will constitute the primary identification for home entertainment products. The Victor name and the "dog-and-horn" symbol which have been associated with them in the past will be retained for selected use with certain

of the products. In this way, according to Mr. Sarnoff, historic associations will be preserved while the primary use of the new RCA mark will relate the home entertainment products with all of RCA's other products and activities.

The RCA President said that the designations of various company activities also are being simplified or altered to reflect more broadly the nature of the particular product line or organization. As an example, he said that the Broadcast and Communications Products Division, which also produces scientific and instructional equipment, will be known henceforth as the Commercial Electronic Systems Division.

As another example, the services of RCA Communications, Inc., the company's international communications subsidiary, will be identified henceforth in advertising and promotion programs as RCA Global Communications.

Another aspect of the new program is the development of terms to describe the types of business in which RCA is engaged. Eight such categories have been established for use in business or public presentations, discussions, and other activities which require a description of the company and its areas of competence. They are *Aerospace Systems*, *Information Systems*, *Education Systems*, *Communications Systems*, *Entertainment Systems*, *Defense Systems*, *Research*, and *Service*. Taken together, according to Mr. Sarnoff, these general categories embrace the full spectrum of RCA's activities, carried on throughout the company's different divisions and subsidiaries.

The communications program was developed and plans for its systematic application throughout RCA were prepared with the aid of Lippincott & Margulies, Inc., communications consultants, under **Walter Margulies**, President. It is being supervised and coordinated within RCA by a new department of Corporate Identification under **Mort Gaffin**, Director, Corporate Identification. Representatives have been designated at each of the RCA divisions and subsidiaries to help in implementing the program in all parts of the company.

C. J. HIRSCH RETIRES

Charles J. Hirsch, Administrative Engineer, RCA Research and Engineering, retired after having been associated with RCA since 1959. A native of Pittsburgh, he received his early education in France and received an electrical engineering degree from Columbia University. Prior to joining RCA, Mr. Hirsch has been Vice President and Director of Research of Hazeltine Research Corporation, Little Neck, New York.

NEW EDP PLANT

RCA will build an \$11.7 million plant in Marlboro, Mass., for the engineering and production of computer peripheral equipment; target for completion is early 1969. The new plant will help to meet the pressing demand for new computer products. The plant will occupy 220,000 square feet of floor space on a 128-acre site on Interstate Highway 495 for the engineering, design, and manufacture of new electronic data processing products. These include data gathering equipment, random access storage units, magnetic tape stations, and other associated devices for computer systems.

NACHMAN TPA FOR INSTRUCTIONAL SYSTEMS

M. W. Nachman has been appointed to serve as Technical Publications Administrator for the new Instructional Systems Division, Palo Alto, California. In this function, he will administer the review and approval of technical papers and coordinate the technical reporting program. He also will promote the planning and preparation of papers for the RCA ENGINEER and other journals both internal and external.

M. W. Nachman graduated from West Virginia University with BSEE degree in 1950 and joined Philco Corporation's TechRep Division, where he became supervisor of special projects in the Engineering Writing Department. In 1955, Mr. Nachman joined RCA as a project engineer on the TALOS system, preparing engineering and test reports. He was promoted to Leader and then Manager of the engineering writing activity for BMEWS; later, he was responsible for the product-improvement group on this project. Mr. Nachman served as chairman of the Zero Defects Program Committee at Moorestown. He also contributed to the development of the Technical Excellence Program at

Moorestown and DEP. He was responsible for configuration management on the SAM-D project. He is now associated with the Instructional Systems Division as Manager, Support Engineering. He is a senior member of the IEEE and has been a member of the public relations committee of the local chapter of the NSPE.



Editorial Representatives

DEFENSE ELECTRONIC PRODUCTS

Aerospace Systems Division

D. B. Dobson* Engineering, Burlington, Mass.

West Coast Division

R. J. Ellis* Engineering, Van Nuys, Calif.

Astro-Electronics Division

H. M. Gurin* Engineering

I. M. Siedeman Advanced Development and Research, and

S. Weisberger Equipment Engineering, Princeton, N. J.

Missile & Surface Radar Division

T. G. Greene* Engineering, Moorestown, N. J.

Communications Systems Division

F. D. Whitmore* Engineering, Camden, N. J.

C. W. Fields Technical Communications, Camden, N. J.

H. Goodman Engineering, Camden, N. J.

M. P. Rosenthal Systems Labs., New York, N. Y.

Defense Engineering

M. G. Pietz* Advanced Technology, Camden, N. J.

I. Feinstein Defense Microelectronics, Somerville, N. J.

H. Epstein Systems Engineering, Evaluation, and Research
Moorestown, N. J.

J. E. Friedman Advanced Technology, Camden, N. J.

J. R. Hendrickson Central Engineering, Camden, N. J.

BROADCAST AND COMMUNICATIONS PRODUCTS DIVISION

D. R. Pratt* Chairman, Editorial Board, Camden, N. J.

N. C. Colby Mobile Communications Engineering,
Meadow Lands, Pa.

C. E. Hittle Closed Circuit TV & Film Recording Dept.,
Burbank, Calif.

R. N. Hurst Studio, Recording, & Scientific Equip.
Engineering, Camden, N. J.

K. C. Shaver Microwave Engineering, Camden, N. J.

R. E. Winn Brdcast. Transmitter & Antenna Eng., Gibbsboro, N. J.

NEW BUSINESS PROGRAMS

L. F. Jones Engineering, New Business Programs, Princeton, N. J.

MEDICAL ELECTRONICS

L. Flory* Advanced Research and Development, Trenton, N. J.

ELECTRONIC DATA DIVISION

G. Smoliar* Chairman, Editorial Board, Camden, N. J.

G. Paff Palm Beach Engineering, West Palm Beach, Fla.

GRAPHIC SYSTEMS DIVISION

J. Gold* Engineering, Princeton, N. J.

RCA LABORATORIES

C. W. Sall* Research, Princeton, N. J.

RCA VICTOR COMPANY, LTD.

W. A. Chisholm* Research & Eng., Montreal, Canada

ELECTRONIC COMPONENTS AND DEVICES

C. A. Meyer* Chairman, Editorial Board, Harrison, N. J.

Solid State and Receiving Tube Division

M. B. Alexander Solid State Power Device Engrg., Somerville, N. J.

R. W. May Commercial Receiving Tube and Semiconductor
Engineering, Somerville, N. J.

I. H. Kalish Solid State Signal Device Engrg., Somerville, N. J.

J. Koff Receiving Tube Operations, Woodbridge, N. J.

K. Loofburrow Semiconductor and Conversion Tube
Operations, Mountaintop, Pa.

R. J. Mason Receiving Tube Operations, Cincinnati, Ohio

J. D. Young Semiconductor Operations, Findlay, Ohio

Television Picture Tube Division

J. H. Lipscombe Television Picture Tube Operations, Marion, Ind.

E. K. Madenford Television Picture Tube Operations,
Lancaster, Pa.

Industrial Tube Division

J. M. Forman Power Tube Operations and Operations Svcs., and

R. L. Kauffman Conversion Tube Operations, Lancaster, Pa.

H. J. Wolkstein Microwave Tube Operations, Harrison, N. J.

Memory Products Division

G. R. Kornfeld Memory Products Dept., Needham, Mass.

Technical Programs

D. H. Wamsley Engineering, Harrison, N. J.

RCA VICTOR HOME INSTRUMENTS

K. A. Chittick* Chairman, Editorial Board, Indianapolis, Ind.

D. J. Carlson Advanced Devel.

R. C. Graham Radio "Victrola" Product Eng.

P. G. McCabe TV Product Eng.

J. Osman Electromech. Product Eng., and

L. R. Wolter TV Product Eng., Indianapolis, Ind.

R. F. Shelton Resident Eng., Bloomington, Ind.

RCA SERVICE COMPANY

B. Aaront EDP Svc. Dept.

W. W. Cook Consumer Products Svc. Dept.

L. H. Fetter Govt. Svc. Dept.

M. G. Gander* Consumer Product Administration, and

K. Haywood Tech. Products, Adm. & Tech. Support,
Cherry Hill, N. J.

W. R. Mack Missile Test Project, Cape Kennedy, Fla.

RCA COMMUNICATIONS, INC.

M. L. Hutchins* RCA Communications, Inc., New York, N. Y.

RCA VICTOR RECORD DIVISION

M. L. Whitehurst Record Eng., Indianapolis, Ind.

NATIONAL BROADCASTING COMPANY, INC.

W. A. Howard* Staff Eng., New York, N. Y.

RCA INTERNATIONAL DIVISION

C. A. Passavant* Clark, N. J.

RCA INSTRUCTIONAL SYSTEMS

M. W. Nachman* Palo Alto, Calif.

FUTURE ISSUES

The next issue of the RCA ENGINEER emphasizes Graphic Systems and Devices. Some of the topics to be covered are:

- Electronics in the composing room
- Electronic type-font design
- Printing processes
- Facsimile in printing
- Computerized typesetting
- Electronic hyphenation and justification

Discussions of the following themes are planned for future issues:

- Automatic testing
- Man-machine alliances in engineering
- Electron tubes: conversion, power, color TV
- Interdisciplinary aspects of modern Engineering
- New RCA computers
- Lasers
- Transportation

*Technical Publication Administrators



RCA ENGINEER

A TECHNICAL JOURNAL PUBLISHED
BY PRODUCT ENGINEERING.
"BY AND FOR THE RCA ENGINEER"

