

OBJECTIVES

To disseminate to RCA engineers technical information of professional value.

To publish in an appropriate manner important technical developments at RCA, and the role of the engineer.

To serve as a medium of interchange of technical information between various engineering groups at RCA.

To create a community of engineering interest within the company by stressing the interrelated nature of all technical contributions.

To help publicize engineering achievements in a manner that will promote the interests and reputation of RCA in the engineering field.

To provide a convenient means by which the RCA engineer may review his professional work before associates and engineering management.

To announce outstanding and unusual achievements of RCA engineers in a manner most likely to enhance their prestige and professional status.

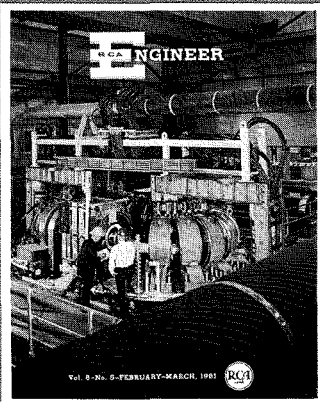

OUR COVER

... the nearly completed C-Stellarator. Spiraled power cables lead to primaries of the coupling transformers at each end of the machine; plasma in the vacuum vessel will act as single-turn secondaries for plasma heating. Magnetic field coils for plasma containment are encased in the massive stainless-steel cases visible surrounding the vacuum vessel. The 8-inch vacuum vessel, in the shape of a 40-foot toroid, is seen at the immediate right of the men. At right background is the central control room, behind the glass window.

THE C-STELLARATOR

...Engineering a Unique Research Facility

The C-Stellarator Project, highlighted in this issue, is an example of a large, complex system requiring the special coordinated skills of engineers from many fields to solve unusually difficult electrical and mechanical problems.

A project group of RCA and Allis Chalmers engineers—called *C-Stellarator Associates*—has since September 1957 managed the development, design, fabrication, installation, and testing of this flexible research facility specified by the scientists of Project Matterhorn, Princeton University, and of the U. S. Atomic Energy Commission. They will utilize the C-Stellarator in conducting high-temperature plasma-physics studies as a part of their continued research efforts toward a greater understanding of the many problems to be solved before controlled thermonuclear fusion can become a reality.

The engineers and scientists of the C-Stellarator Associates have been drawn from the various RCA product divisions, the RCA Laboratories, and from the Allis Chalmers organization. The latter concentrated on the motor-generator system, mechanical structure, magnetic field coils for plasma confinement, and controls for these subsystems.

RCA Electron Tube Division engineers developed, designed, and built the ultra-high-vacuum system; IEP Broadcast Division engineers the r-f power equipment; and IEP Electronic Data Processing engineers the control timer and the data-handling system.

Because of the concentration of megawatts of d-c and r-f power pulses in the limited space surrounding the 40-foot toroidal vacuum vessel, many challenging problems had to be resolved mutually in designing and building the massive mechanical structures necessary to withstand the extremely high stresses. The engineers associated with this venture must be commended for the manner in which they cooperated with one another in solving these problems. The successful engineering of this complex research facility exemplifies their professionalism, dedication, and determination.

The new knowledge and advanced skills gained through work on the C-Stellarator combine to give RCA valuable engineering potential for important future industrial and defense applications.



D. F. Schmit

D. F. Schmit*
Staff Vice President,
Product Engineering
Radio Corporation of America

*Senior RCA Representative,
C-Stellarator Associates

CONTENTS

The Engineer and the Corporation: The Nature of Engineering Supervision	H. M. Elliott	2
Design of the C-Stellarator	Dr. L. B. Headrick	6
Data Handling for the C-Stellarator	A. S. Buchman and R. T. Ross	11
Ultra High Vacuum—C-Stellarator System Involves Advanced Techniques	K. Dreyer and J. T. Mark	14
Equipment Action Sequence Timer—Precision for the C-Stellarator	P. E. Slavin	19
The Maser—Microwave Amplification by Stimulated Emission of Radiation.	J. M. Brumbaugh, D. Karlsons, L. C. Morris, and Dr. H. J. Gerritsen	21
New, Rugged, Ceramic Pencil Tubes for CW Use at UHF	L. P. DeBacker and C. J. Gurwacz	26
The David Sarnoff Outstanding Achievement Awards		28
Plasma Physics: Part I—Natural Phenomena and Thermonuclear Fusion	Dr. M. P. Bachynski	30
Automatic Steering and Gyro-Compass for Large Ships	Irving F. Byrnes	34
A Technique for Measuring Symmetrical Magnetic Fields	L. J. Bazin	38
Technical Features of the TIROS Satellite System	G. Corrington and C. C. Martinelli	40
Performance of TIROS I	A. Schnapf and S. Sternberg	45
Military Application of Computer Techniques	A. D. Beard	50
Pen and Podium		53
Patents Granted		53
Engineering News and Highlights		54

VOL. 6, NO. 5 • FEB.-MAR. 1961

Copyright 1961
Radio Corporation of America
All Rights Reserved

PRINTED
IN
U.S.A.

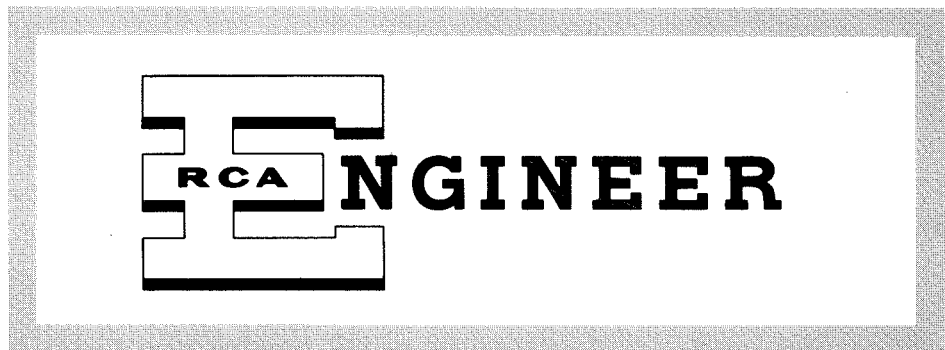

Editorial Advisory Board

- E. I. Anderson, Chief Engineer,
RCA Victor Home Instruments
- J. J. Brant, Director, Personnel
- C. C. Foster, Mgr., RCA REVIEW
- M. G. Gander, Mgr., TV and Radio Engineering
RCA Service Co.
- C. A. Gunther, Chief Defense Engineer,
Defense Electronic Products
- J. Haber, Director, Community Relations
- E. O. Johnson, Chief Engineer,
Semiconductor and Materials Division
- W. C. Morrison, Mgr., Engineering Plans &
Services, Industrial Electronic Products
- G. F. Floridis, Mgr., General Employment
- H. E. Roys, Chief Engineer,
RCA Victor Record Division
- D. F. Schmit, Vice President, Product Engineering
- E. C. Hughes, Mgr., Commercial Engineering,
Electron Tube Division
- C. M. Sinnott, Director, Product Engineering
Professional Development

RCA ENGINEER Staff

- W. O. Hadlock, Editor
- E. R. Jennings, Assistant Editor
- Miss C. N. Serafino, Editorial Secretary
- J. L. Parvin, Art and Production
- J. O. Gaynor, Photography

Engineering Editors

- K. A. Chittick, Mgr.,
Engineering Administration,
RCA Victor Home Instruments
- S. F. Dierk, Technical Publications Administrator,
Industrial Electronic Products
- C. A. Meyer, Mgr., Commercial Engineering
Technical Services, Electron Tube Division
- L. A. Thomas, Mgr., Technical Services,
Astro-Electronics Division,
Defense Electronic Products
- F. D. Whitmore, Technical Publications
Administrator, Defense Electronic Products

THE WORD *supervision* implies a number of things—among these are effective direction of individuals, control of a group activity, achievement of productive results, and understanding of organizational and budgetary concepts. To engineering, it means that effective supervision involves talents of leadership and techniques of administration in addition to technical know-how.

What these special talents and techniques are and how they work in practice is important . . .

. . . to the engineer, so that he can better understand the forces that direct his group and thus his individual work;

. . . to the engineer who hopes to progress into super-

vision, so that he can better know and develop the required talents; and

. . . to the engineering supervisor, so that he can better understand his role and thereby improve his effectiveness.

Therefore, a supervisor should be familiar with estimating techniques and his company's policy of pricing and overhead determination. Knowing what these are, what they are for, and why they vary under different circumstances helps to give him a needed insight into his company's operation. Similarly, an understanding of model shop and factory procedures, rules and regulations of the purchasing department, and the why's and wherefore's of the drafting group make for better planning.

A good supervisor is a good personnel man. He must know the detailed rules for salary increases and must be able to make fair and equitable recommendations for all members of the group, always making sure that the individual engineer knows where he stands. He must be able to offer professional and sometimes personal guidance, whether it be on a graduate study program or the pitfalls of buying a house. And lastly, he has to keep in mind the training of a successor, which means regularly evaluating the abilities of his engineers and helping to develop those who have the qualities of leadership.

Communication

Vertical communication is important both to the supervisor's group and to higher management. From the technical details of a project, the "big picture" is not always self-evident. Engineers at every level must have knowledge of the broad aspects of the plans and policies of the over-all operation. Similarly, those at the policy-making levels should be regularly informed of the problems as well as the achievements of engineering groups to be certain that the over-all operation rests on a firm base.

Horizontal communication, or coordination, with other engineering or service groups is also vital, if all parts are to mesh. Every activity has special requirements and problems, and a good supervisor makes an effort to understand them, as well as to make known those of his own group.

Effective communication involves many techniques, ranging from personal contact through written status reports to the detailed documentation of the work in formal technical reports—the latter a special requirement for engineering activities. It is the supervisor who must monitor all the appropriate communication media.

Group Leadership

The third area, group leadership, is the most important and more subtle than the first two. In reality, there are no manuals to refer to, no formal procedures to consult. There are certain ground rules, yes; but their application requires personal judgment and tact—a cookbook procedure is not sufficient. Some of these ground rules, or attributes, are:

- 1) intense desire to manage, coupled with a personal enthusiasm for the special responsibilities of supervision and the goals of the company; this kind of interest must go beyond the technical aspects of the engineering work;
- 2) ability to understand and get along with people;
- 3) willingness to delegate responsibility and authority, when appropriate;

The Engineer and the Corporation

The Nature of Engineering Supervision

by H. M. ELLIOTT, Mgr.
Engineering

Commercial Systems Dept., Electronic Data Processing Division
IEP, Camden, New Jersey

vision, so that he can better know and develop the required talents; and

. . . to the engineering supervisor, so that he can better understand his role and thereby improve his effectiveness.

The essential concepts involve: 1) the techniques of direct engineering-group supervision; 2) the transition—i.e., the differences—between engineering activity and engineering supervision; and 3) the actions of the supervisor relative to a multi-level organization.

BASIC TECHNIQUES AND PERSONAL QUALITIES

To be a good supervisor, an engineer must have an intense *desire to manage*. He must know his company, must be competent in his engineering field, and must know and understand people. Furthermore, as a supervisor, he must, in time, become proficient in three primary areas: 1) the specific duties of supervision, which involve the procedures necessary to direct an engineering group; 2) communication, since no group operates in a vacuum; and 3) group leadership, a more subtle, personal technique.

Specific Duties

The most important duty of a supervisor is that of planning and direction. While an engineer is primarily concerned with specific components, equipment, or techniques, a supervisor must formulate an over-all work plan. He must come up with a schedule, appropriate manning, and a realistic budget, and most important, he must see to it that his engineers keep to that schedule

- 4) ability to make intelligent decisions, sometimes of necessity quickly, and to be right a majority of the time;
- 5) the fortitude to establish and maintain direction—to be firm without being inflexible, to be open-minded without losing control—while always accepting personal responsibility for group actions.

The areas of specific duties and communication previously discussed encompass well-defined knowledge and techniques. The ability to apply the above attributes of group leadership is a subtle talent, one that may often be developed from traits existing in the individual.

TRANSITION FROM ENGINEER TO SUPERVISOR

When an engineer assumes a supervisory assignment, it is extremely important that he realize that the emphasis is on administration and management. Although he must be equipped to make major technical decisions, he must now rely more and more on the engineers in his group for detailed technical aspects of the effort.

In line with this, an engineer's initial venture into supervision begins with an important period of reorientation. There are a number of new concepts and attitudes he must deal with, and some pitfalls he should avoid. Some or all of these affect every supervisor at some time or other.

The "Do It All Myself" Tendency

With increased responsibility, the new supervisor may worry that things are getting away from him, or that his engineers are not quite as capable as they should be—even though not too long ago, as co-workers, he may have considered them completely capable. As a result, he tries to shoulder too much of the detailed work of the group. The new supervisor must curb the tendency to interfere with engineers' work in order to "get on with the job." Even if, in the beginning, he may be able to do it faster and better, such action does not promote harmony in the group, nor does it promote the development of the group as an effective engineering organization. This tendency must be corrected so that he can more efficiently direct his energies to true supervisory areas.

Delegation of Responsibility Requires Delegation of Authority

The new supervisor who delegates responsibility without the necessary authority to accomplish the assigned task is really a victim of lack of confidence in himself. If he does this, he places his subordinates in an untenable position and by not indicating confidence in them they, in turn, will have less confidence in him. The supervisor, however, regardless of delegation of responsibility, will at all times be the one who is accountable. There can be no "buck-passing" on this issue.

Establish Time Limits Reasonably, and Monitor Firmly

Time limits on tasks should be arrived at by discussion, not arbitrarily, and should be checked on. There is nothing to be gained by forcing an engineer to attempt what he feels is an impossible task, and then berating him for not accomplishing it. In monitoring tasks, immediate commendation or criticism is far more effective than waiting until some more formal occasion.

A Supervisor Is Not "One of the Boys"

Tact, a necessary attribute for any supervisor, is particularly important to a new supervisor. The engineers who used to work with him now work for him. Relationships are in the process of changing; initially, there may be resentment on the part of some of the people, even though only subconsciously.

A new supervisor may start off with the feeling that he will still be "one of the boys," and that his group is different. This is not so. No matter how good a working relationship is established in the group, the supervisor is someone set apart. This difference, however subtle, *must exist* if he is to manage effectively. The willingness and ability to assume this role successfully is a very real test of supervisory talent.

The Supervisor Is Not a Super-Engineer

As time goes on and a new supervisor becomes more concerned with managing and less with the detailed technical aspects of the job, he may actually become less qualified to personally accomplish highly technical aspects of the work. The supervisor cannot look upon himself as a super-engineer, more expert than the experts, whatever the field, merely by mistaking his supervisory position for up-to-date technical know-how.

Experience in engineering leadership and administration cannot be interchanged with direct, continuing professional experience in detailed engineering work. The fork in the road was reached when the engineer agreed that supervision was what he wanted. Few, if any, can travel both roads successfully, simultaneously.

Checking Progress

The supervisor must continually check the progress of his engineers if he is to maintain control. He should never assume that a job will be done; he should verify it for himself. This means more than a phone call or the receipt of a progress report. He should make the rounds—of the lab areas, the model shop, or the factory—and see for himself.

A Sixth Sense

There is an art to sensing that something is slipping and perhaps letting it slip just enough so that when the supervisor intervenes, the engineers realize he is justified in doing so—and yet, not letting things slip enough to jeopardize the project. This is an art that can only be learned by experience. The object is to guess wrong a minimum number of times.

Herbert M. Elliot, in addition to his management duties at RCA, maintains an active interest in the concepts and practices of engineering management. He is active in the IRE Professional Group on Engineering Management and, at the 1959 Western Joint Computer Conference, presented "The Computing Machine—Slave Labor in a Free Society." In 1960, he participated in the Annual Industrial Engineering Seminar on Engineering Management at Cornell University. He recently contributed a chapter to the forthcoming book, "Utilization of Engineers," being published by the American Management Association in February 1961. (For a detailed biography, see his article, "RCA and Commercial Computer Systems," RCA ENGINEER, Dec. 1960-Jan. 1961.)



Develop Mutual Trust

A reciprocal relationship, a sense of mutual trust, must be developed. Just as the supervisor must learn to trust the ability of his engineers, so must they learn to trust him. He is the buffer between them and the external world. Within the group, he may criticize, he may reprimand. But outside the group, he is the only one responsible for the group's actions. The new supervisor should realize it, and by his actions, the members of the group should know it.

ACTIONS WITHIN THE LARGER ORGANIZATION

The engineer who has elected the path of supervision must also be concerned with the actions and interrelations of the management organization. The characteristics of higher management levels in terms of the techniques used may be more subtle than those of direct concern to the new supervisor; but they are no less definite. To pause for a moment and consider the situation, a simple, but nevertheless valid, comparison can be made:

First, the engineer is an individual who works with things—definite, inanimate objects. Next, the first-line supervisor is an individual who works with people, and to a significant extent, with things in the sense of directing others how to work with these things.

Second-level supervision works with people who, in turn, work with people. The tie to definite, discrete, inanimate objects—to hardware—is, for all intents and purposes, broken. The engineer-supervisor now deals with *other supervisors*—a fact even more evident at yet-higher levels.

To deal with these inherent characteristics of management, the supervisor must develop some abilities more than others: 1) the planning function; 2) organization know-how; and 3) so-called managerial gambits.

The Planning Function

The total planning activity may be considered as a three-dimensional activity. Each dimension exists at all levels of supervision; however, the emphasis shifts at higher management levels. These are project planning, alternate planning, and counter planning.

Project Planning is a basic and straightforward action involving development of a project plan, from which is derived a corresponding budget and schedule. The prime source for such figures is first-line supervision.

Alternate Planning can best be described as variations on a theme, where the theme is the project plan. More than one approach may be considered in the light of company policy (or a contemplated change thereof), as a function of market conditions, etc. Here, it is important to consider the common characteristics of the various alternatives, so that if the necessity arises, a switch may be effected with a minimum loss of time and money. Alternate planning involves first-line supervision, but almost always in conjunction with second- and third-line supervision.

Counter-planning contains the elements of the first two dimensions and, in addition, introduces a third. While the first two classifications deal, in the main, with processes influenced by competitor's actions, or in a broad sense, market conditions, counter-planning is influenced primarily by internal obstacles to assigned goals. In other words, there is often more than one

means to an end. How many are there? Of these, how many are available? And under what conditions is one preferred? This is counter-planning. This, almost always, involves supervision above first-line.

Organizational Know-How

The ability to create an organization under him, and to understand and work productively within the organizational structure around and above him is essential to any supervisor.

Regardless of how complex the over-all organization, it is important for the supervisor to understand the levels of authority and responsibility of the line functions, and to be cognizant of the roles played by staff activities. He must remember that at each succeeding level, authority is superior to that existing at preceding levels—superior authority that may be exercised with dispatch, when necessary. It is also a supervisor's duty to make this fact clear to his subordinates, and to keep them informed as to the structure of the whole organization and their place in it.

It is axiomatic that any successful organization, simple or complex, must have a clear line of authority and be capable of decisive action. This basic principle can be related to the people who compose the organization as follows:

- 1) *Common goals, common purpose*: A group, by definition, is an aggregate of individuals having something in common. In the case of an engineering group, the essential common goals may be completion of an equipment design project, development of new techniques, or the meeting of a production schedule. The supervisor must bring home to his group the real nature of their goals, in order to achieve group identification.
- 2) *Group identification*: The individuals in the group must have a sense of belonging, and of belonging voluntarily. This implies a sense of pride, not of oppression. There should be a feeling of a working organization—that the group has a logical reason for existing, not happenstance. Internally, there can be disagreements or arguments, but never without control. Externally, the group stands united. The group, as one entity, accepts criticism or commendation through its supervisor.
- 3) *Enthusiasm, based on tangible rewards*: Lastly, there must be personal reasons for individuals to work together as a group. For each one, there must be a tangible gain—whether it be professional recognition, promotion, a raise in pay, or something else. Whatever it is, it must be realizable.

Though the above list applies essentially to the individuals within the group, together they define a policy that the group pursues as an entity. This can be stated very simply: a policy of *enlightened self-interest*. Much depends on the abilities of the supervisor to create and maintain these organizational attitudes.

Multi-Group Organizations

The methods discussed earlier for supervising a group of engineers are still valid when applied to a complex group—that is, a group which, in turn, is composed of groups. However, now the problem facing the supervisor is one, not of direct control, but of remote control.

The supervisor now gets his information second-hand, possibly third- or fourth-hand. As he once had to rely on his engineers to do their technical job, now he must rely on his supervisors to keep him informed.

The supervisor of a multi-level group must operate between two limits. On the one hand, he must be careful not to by-pass his supervisors and deal directly with the engineers, or circumvent one level of supervision and deal with another. And on the other hand, he should not establish a rigid organization and require everyone to go through channels at all times. In some respects, supervision of a complex group is a paradox: The supervisor, realizing that he manages by remote control, must make an effort to make it as personal as possible without undermining the authority of any of his people.

The principles of group identity, aims, and objectives are in essence the same as previously discussed with respect to the primary group. However, the number of inter-personal conflicts increases as the sum power of the number of people involved. The resolution of group conflicts sometimes can get rather complicated, thus requiring even greater administrative ability from the multi-level supervisor.

Development of Managerial Gambits

Planning and organization may be classed as formulaic areas; they are essentially structural. Managerial gambits are the techniques used to implement a plan through use of the organization.

There is value in establishing rapport, in seeing the other fellow's point of view, in talking things out, in "getting everybody on board." But, these are not the only methods. There are times when a little needling goes a long way, or when a fast decision and a direct order are most effective. Particularly when higher in the management structure, the principle of "togetherness" is less applicable; it is more appropriate to say that the supervisor is here a participant in a *multi-part game*—a game in the mathematical sense, and a serious game at that, involving decisions and a flexible plan based on estimates of probable actions of others and probable effects of his own plans. Some of these gambits form a pattern and may be classified:

Tacking. Project planning at the level of first-line supervision is usually straightforward, and for relatively short time periods—often on an annual basis, with a semi-annual review for budget modification. Timing checkpoints are established; if they are not achieved, increased effort must be applied. The direction is fixed, almost rigidly so. However, at higher levels, objectives may require two or three years to accomplish. The same rigid planning cannot always be used. The manager of a multi-level group must learn to be flexible, which is not the same as malleable. He must learn to change direction when it becomes necessary; and at the same time plan points of departure from which he can resume the path toward the original objective. In management, on many occasions, the shortest distance (in point of time) between two points is not a straight line.

Arbitrary Decisions—The Principle of Unilateral Logic. There are times when a supervisor must make a decision and implement it quickly. The decision may run counter to established procedure, or negate a previous decision (not necessarily made by him). For one

reason or another, it may be inadvisable to hold a meeting. Consequently, the managerial decision may well appear arbitrary to subordinate personnel. The frequency of such action must be watched carefully, since management by apparent whim does not last very long. This technique does illustrate a basic principle: Each level of supervision must justify its actions and operate logically with respect to the next higher level, since authority and responsibility at each level is subject to control and revocation from above. However, in the other direction, although management must be as logical and consistent as possible with respect to subordinate levels if control is to be maintained, nevertheless (by the very definition of a multi-level organization) there are occasions when unilateral action is necessary. It is important for all cognizant parties to remember this.

Maximize Gains and Minimize Losses. Taking the long view, a supervisor—especially at higher levels—must, in effect, be a gambler with restraint. To adopt the policy of playing everything completely safe means standing still. To proceed on the basis of master-minding the operation, of personally directing all phases, can end in catastrophe. The successful supervisor must always be prepared to risk a loss—time or money—but before doing so, he must estimate the size and the probability of the gain to offset this. Over a long period of time, this is the best alternative; but operationally, this means that he must "die a little every day."

Action on the Basis of Always Being Found Out. The foregoing discussion of specific managerial techniques may have given the impression that intrigue or subterfuge is being advocated. This is not so; what is being advocated is maneuverability. At the same time, the manager should be straightforward and aboveboard. Not only should he always consider his actions in the light that his objectives will generally become known, but he should take it upon himself to make his objectives known. And obviously, whatever action he plans to take should always be governed by the probable reactions of the other people, once his objectives are known.

SUMMING UP

The role of engineering supervision demands talents and techniques that are inherently different from engineering work. Some, like the specific duties of administration and techniques of communication, can be readily learned. Some others—like the subtle art of directing people by inspiration rather than perspiration—are dependent on development of innate, personal qualities of leadership.

The successful engineer-supervisor must be aware of the nature of his responsibilities and the detailed aspects of his company's organization and policies. And, very important, he must accept the truth that supervision means technical and administrative direction, rather than immediate concern with all the technical details.

Finally, supervision involves participation in a multi-part game, in the mathematical sense. As planner, leader, and decision-maker, he must estimate obstacles and plan around them, think and act quickly, and be flexible yet decisive—always keeping the long-term objectives of his group and his company in mind.

Design of the C-STELLARATOR

by **DR. L. B. HEADRICK**
Staff Engineer

*High-Power Microwave Engineering
Electron Tube Division
Princeton, N. J.*

Controlled thermonuclear fusion promises an almost unlimited future source of electrical power; before this can be achieved, extensive research on high-temperature plasmas is essential. The C-Stellarator is a large-scale facility for such research. RCA has participated heavily in its engineering design, which includes r-f schemes for plasma heating to 100 million °K, high-intensity magnetic fields, important advances in ultra-high-vacuum techniques, and precise control and data-handling methods. This article and the three following describe some of this engineering accomplishment, while the article on plasma physics gives an insight into some of the basic concepts involved.

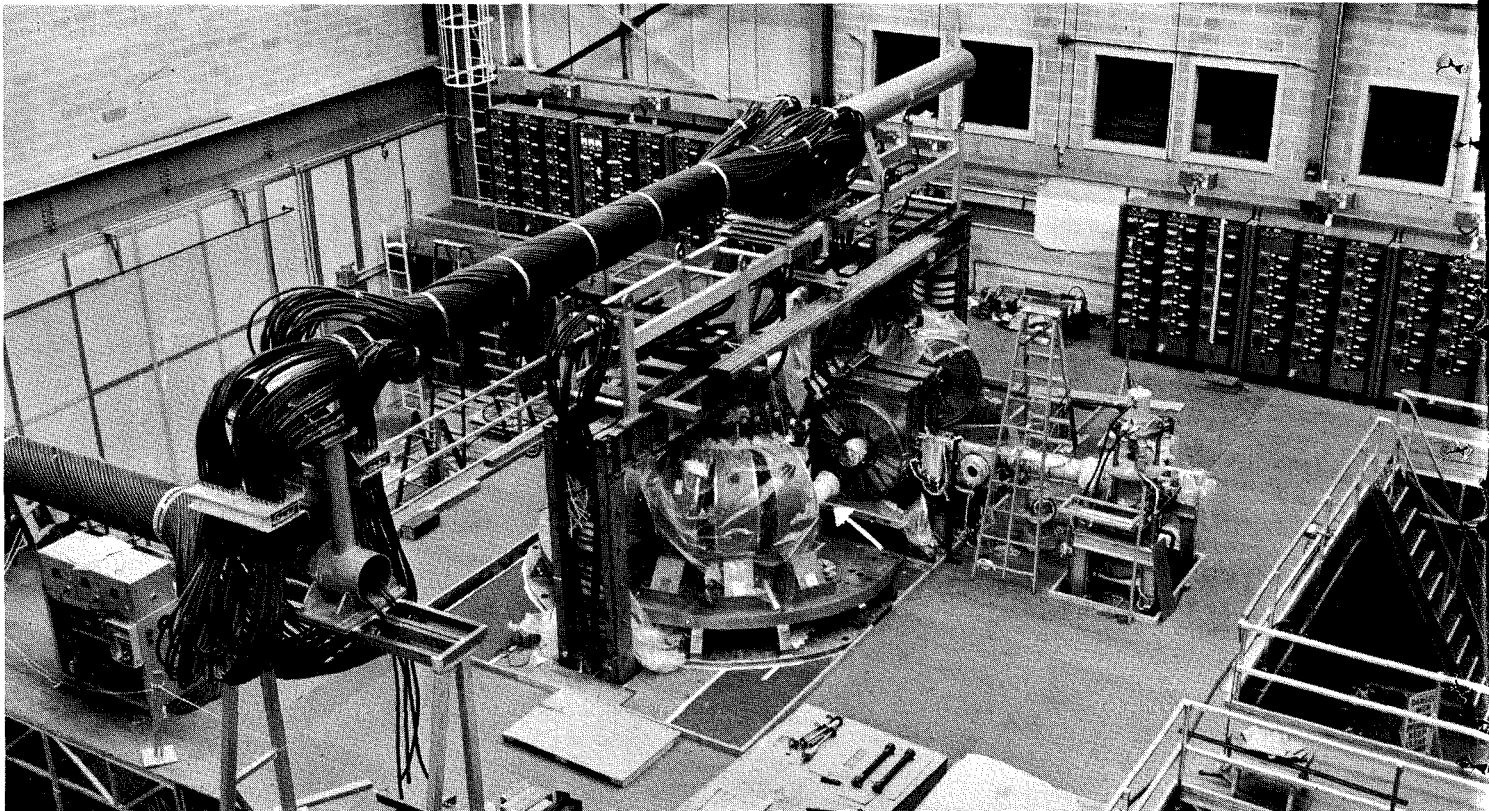

THE C-STELLARATOR facility (see cover and Fig. 1) is a research tool for studying the conditions necessary for the control of hydrogen fusion, the knowledge of which is required for the eventual design of a controlled-hydrogen-fusion power generator. Research with the C-Stellarator will involve the study of plasma-physics phenomena; as such, it is designed with a flexibility of operating conditions that permit a wide variety of physical conditions and measurements.^{1,2}

To satisfy these goals, the C-Stellarator is engineered to generate and confine hydrogen plasma at temperatures around 100 million °K and is instrumented for a wide variety of diagnostic data. Its design relies heavily on d-c power engineering, electronics, and electromechanical technology—including r-f heating schemes for the plasma, high-intensity magnetic fields, ultra-

high-vacuum systems, and complex control and data-handling systems.

Many research and engineering groups of RCA contributed to the design and construction of the C-Stellarator through the C-Stellarator Associates, a project group formed jointly by Allis Chalmers and RCA. The C-Stellarator will be used in the Matterhorn Project* at the Forrestal Research Center of Princeton University, part of the Atomic Energy Commission's Sherwood Project for Peaceful Applications of Atomic Energy.³

The name "Stellarator" was derived from *stellar generator* by Dr. Lyman Spitzer, Jr., Head of the Dept. of Astronomy at Princeton University and Director of the Matterhorn Project, who conceived the idea of the stellarator from

his astrophysical studies of the energy processes of the sun and stars.

CONTROLLED HYDROGEN FUSION

Control of hydrogen fusion will permit the controlled production of energy in a manner similar to the processes operating continuously in the sun and stars. It involves control of the kind of fusion reaction which, occurring instantaneously, produces the massive, destructive force of the hydrogen bomb.

Controlled hydrogen fusion on the sun takes place at temperatures of the order of 20 million °K and at many atmospheres of pressure. However, on earth, much higher temperatures—of the order of 200 million °K—and only approximately 26 atmospheres of pressure are the most likely conditions for controlled hydrogen fusion.^{4,5} For example, if hydrogen is admitted to a vacuum vessel at a pressure of 10^{-2} mm-Hg (equal

* The "Matterhorn Project" has been officially re-named the Princeton Plasma Physics Laboratory.

to about 10^{-5} atmospheres) at about room temperature (300°K), the pressure at a temperature of 200×10^6 °K would be equal to $4(200 \times 10^6) (10^{-5})/300$, or about 26.6 atmospheres. The factor 4 in this equation results from the fact that at 2×10^8 °K, the deuterium is completely ionized. Thus, one H_2 molecule becomes four particles, two H_2 atoms and two electrons.

supply of low-cost fuel material and the absence of any radioactive disposal problem make the controlled-hydrogen-fusion reaction a very attractive source of power for the future.

PRINCIPLE COMPONENTS

The *C* indicates that the C-Stellarator is a third-generation basic design. The *A* version was the original laboratory

either 100 or 200 kc. The amplifier has a pulsed power output of 400 kw for about 10 milliseconds and can provide a continuous output of about 70 kva. This system initiates the plasma by stripping the deuterium atoms of their single electrons, thereby ionizing the gas.

The ohmic heating system consists of a pulse amplifier designed to use six to ten RCA super-power tubes. A pulse ranging from 1 to 5 milliseconds is supplied to the plasma through a coupling coil. The pulse has a plasma current of 34,000 to 50,000 amperes (depending on the rise time). This system can also be pulse-operated at 10,000 cycles for the study of plasma heating at low frequencies. The plasma acts as a one-turn secondary and the inductively coupled coil as the primary of a coupling transformer. These pulse currents provide the major part of the initial heating of the plasma and are expected to raise the temperature to about 10^6 °K. At higher temperatures, the electrical resistance of the plasma becomes so low that ohmic heating becomes ineffective; therefore, ionic heating methods are used for plasma heating above 10^6 °K.

There are two ionic heating units. One, a low-frequency ringing circuit, operates between 30 and 200 kc and has a power output of about 50 Mw for about two milliseconds. Heating by this low radio frequency is called magnetic pumping. The other unit operates at 7 Mc or between 15 and 40 Mc and has a power output of about 14 Mw. Heating by this higher radio frequency is referred to as resonant heating. These generators are inductively coupled directly to the plasma by means of tank-circuit coils located around the ceramic insulating sections of the vacuum vessel. These two r-f ionic heating units are expected to provide the major part of the plasma heating at high temperatures and to increase the plasma temperature from 10^6 to 10^8 °K.

Magnetic Containment

The magnetic containment of the plasma is provided by two sets of coils. One is a set of short solenoids which encircle the vacuum vessel (Figs. 2, 4). The other is a long, low-pitch helix providing improved field uniformity over the cross section of the plasma (Fig. 3).

In the main field coils, the copper windings of the solenoids have an inside diameter of 20 inches, an outside diameter of 40 inches, and a length of 5 to 8 inches. They are covered with heavy stainless-steel cases rigidly mounted to the machine frame.

These coil cases and mountings are made of special age-hardened nonmagnetic stainless steel strong enough to support large forces of the order of $3 \times$

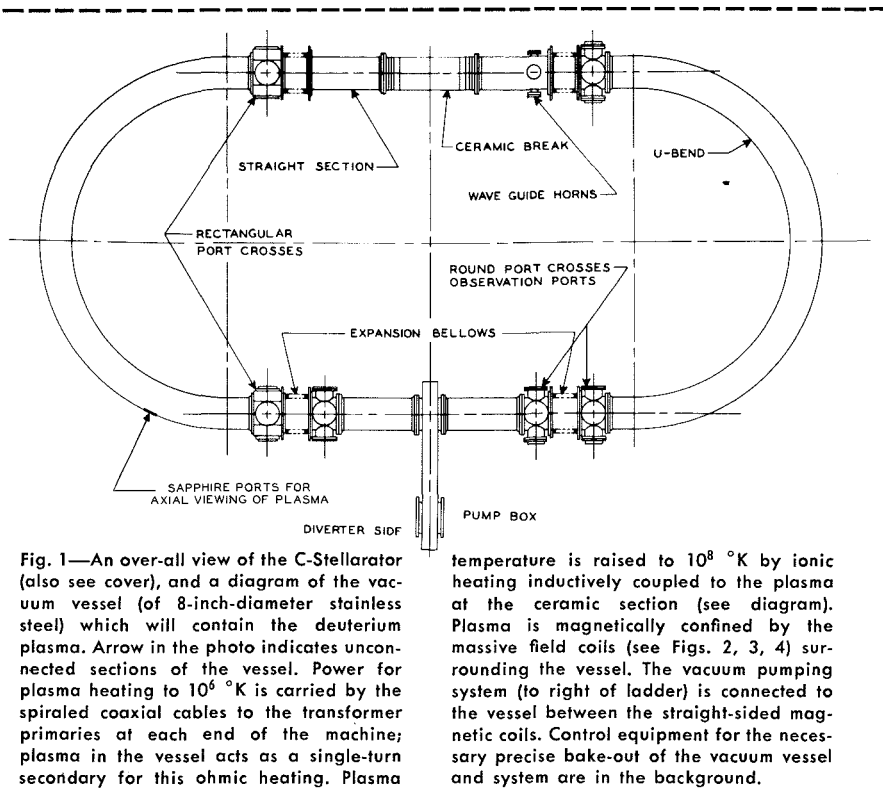

Fig. 1—An over-all view of the C-Stellarator (also see cover), and a diagram of the vacuum vessel (of 8-inch-diameter stainless steel) which will contain the deuterium plasma. Arrow in the photo indicates unconnected sections of the vessel. Power for plasma heating to 10^6 °K is carried by the spiraled coaxial cables to the transformer primaries at each end of the machine; plasma in the vessel acts as a single-turn secondary for this ohmic heating. Plasma

temperature is raised to 10^8 °K by ionic heating inductively coupled to the plasma at the ceramic section (see diagram). Plasma is magnetically confined by the massive field coils (see Figs. 2, 3, 4) surrounding the vessel. The vacuum pumping system (to right of ladder) is connected to the vessel between the straight-sided magnetic coils. Control equipment for the necessary precise bake-out of the vacuum vessel and system are in the background.

Controlled-hydrogen-fusion power-generating stations, when developed, will produce millions of kilowatts of power. They will be several times larger than any power generators presently operating, and will be capable of supplying large sections of the United States with electric power.⁶

The hydrogen-fusion reaction — the combination of two atoms to form one atom — converts mass to energy. This conversion provides a large source of energy which is free of radioactive end-products and which can be obtained from an almost inexhaustible supply of deuterium (heavy hydrogen) in sea water.

It has been estimated that the deuterium which can be separated from one gallon of sea water at a cost of about ten cents could provide approximately 10,000 kw-hr of energy, or the average amount used by a family of five in one year. The dual advantages of a plentiful

model made to demonstrate the principles of operation and objective potential. The *B* models, still in operation, have been used for further study to provide design information for the C-Stellarator.

The main features of the C-Stellarator (Fig. 1) are the provision of three methods of plasma heating, the high-intensity magnetic containment field, the demountable ultra-high-vacuum system, and the high-speed vacuum pumping system.

Plasma Heating

Three different heating generators initiate the deuterium plasma and raise its temperature to the desired value. These generators provide breakdown, ohmic, and ionic heating to the plasma.⁷ The ionic heating is sometimes called magnetic pumping and resonant heating.

The breakdown-heating system is composed of a power amplifier having a master oscillator which can be operated at

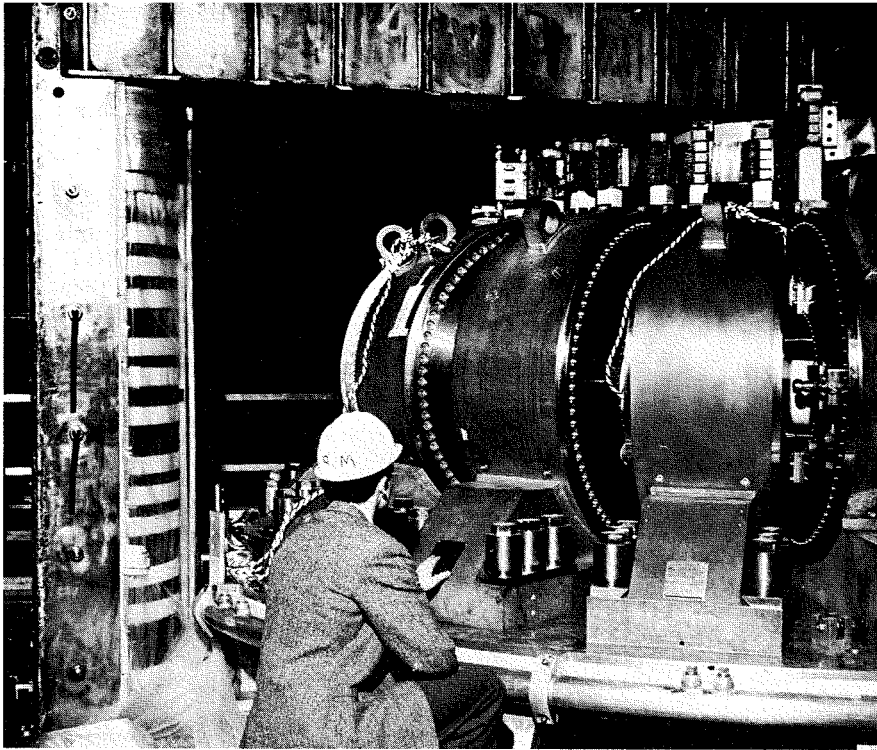

Fig. 2—Magnetic containment coils for half of one end-section of the vacuum vessel. The short solenoids contained in these massive stainless-steel cases have copper-coil windings, and provide pulsed magnetic field strengths up to 55,000 gauss. Structure at top and left is the ohmic-heating transformer primary.

10⁶ pounds. The coils are designed and mounted to provide pulsed magnetic field strengths up to 55,000 gauss. Uniformity along their magnetic axes is within about 2 percent. They are made in separate short sections to allow for adjustment of their magnetic axes and to provide sufficient space for electrical leads and water-cooling connections between the coils. Cooling is required because of the high currents (40,000 to 45,000 amperes for about 2 seconds) needed to produce the high magnetic field.

One of the helical stabilizing windings, without supports, is shown in Fig. 3. These windings are designed to fit close to the outside of the vacuum vessel inside of the main containment field coils. The field from these stabilizing windings, in addition to correcting non-uniformity over the cross section of the main containment field, improves plasma stability by permitting rotation of the axial field so that no lines of force, off the magnetic axis, close on themselves.

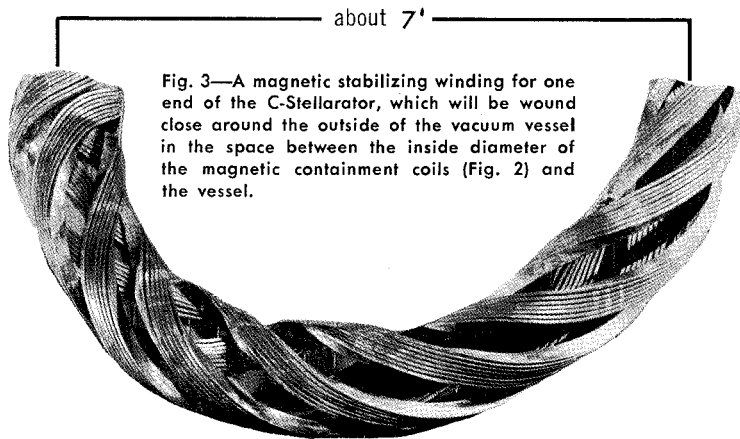

Fig. 3—A magnetic stabilizing winding for one end of the C-Stellarator, which will be wound close around the outside of the vacuum vessel in the space between the inside diameter of the magnetic containment coils (Fig. 2) and the vessel.

Vacuum Vessel and Pumping System

The vacuum vessel of the C-Stellarator, (Fig. 1) has an axial length of about 40 feet and an inside diameter of 8 inches. The entire vessel is wrapped with heaters and electrical insulation.

[For a detailed description and illustrations of the vacuum system and the new vacuum-engineering techniques developed therefrom, see J. T. Mark, this issue.]

The major parts of the vessel are made of welded nonmagnetic stainless-steel tubing having a wall thickness of 0.109 inch. The two straight sides of the vessel are each about 5 feet long. The U-bends at each end are made from additional straight sections of welded tubing bent to form semicircles having a radius of about 3½ feet.

For initial operation, the vacuum-pumping system is connected near the center of one straight side of the vessel, and the insulating section for breakdown and power input is near the center of the other straight side. Each straight side is composed of several sections which have

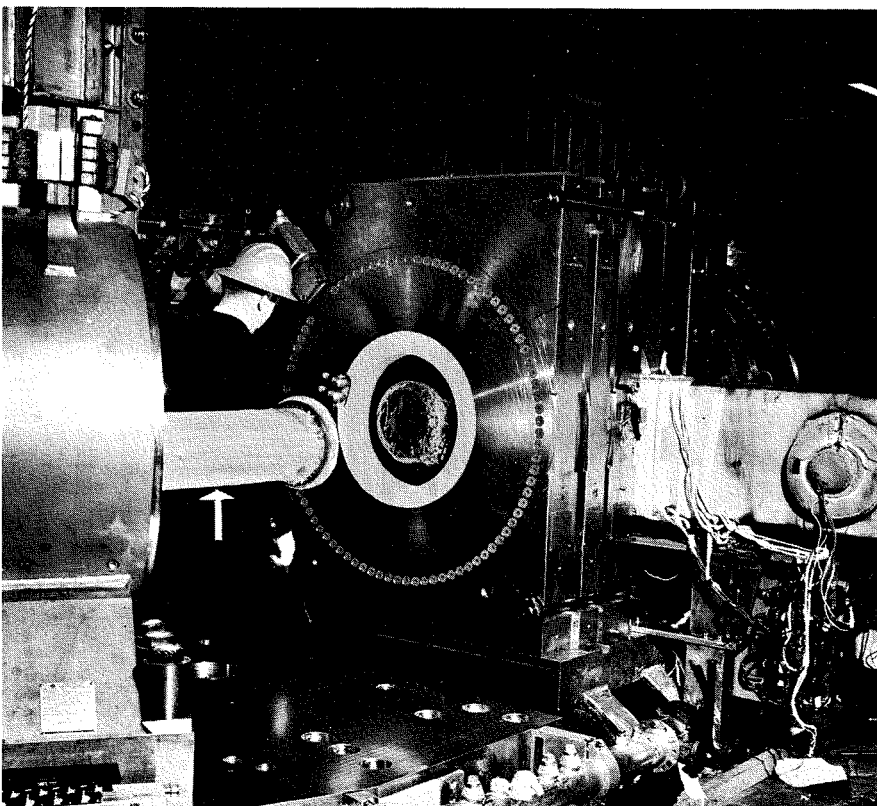

Fig. 4—Magnetic containment coils for one straight section of the vacuum vessel. (End-section coils of Fig. 2 are visible at left.) At right is the vacuum-system connection to the vessel. Arrow indicates vessel, with space left for observation ports to be added (see diagram, Fig. 1).

machined flanges for gold-wire *O*-ring seals at both ends.

Two different sizes of ceramic sections can be used for inductive coupling of high-frequency power to heat the plasma by various methods at different frequencies. These high-alumina, vacuum-tight cylinders, developed by the Frenchtown Porcelain Company especially for the C-Stellarator, have high strength and low power loss. The two sizes have inside diameters of $7\frac{1}{4}$ inches and 18 inches, and are about 12 inches and 44 inches long, respectively. The ceramic cylinders, used to couple r-f heating power to the plasma, have vacuum-tight Inconel-X compression seals at both ends. Flanges are welded to these seals to accommodate gold *O*-ring seals so that any of different-sized high-alumina cylinders can be mounted in the vacuum vessel. The four bellows sections, located near the ends of each of the straight sides of the vacuum vessel, permit easy assembly and compensate for mechanical changes during thermal cycling.

Commercial pumps, with traps of special design and an over-all pumping speed of 600 liters/second are used, which are capable of a base pressure around 10^{-10} mm-Hg. A specially designed, bakeable, ultra-high-vacuum valve separates the pumping system from the vessel and controls the pumping speed at levels below the maximum during operation of the C-Stellarator.

The ultra-high-vacuum portion of the pumping system is bakeable and demountable. All connections from the top of the mercury diffusion pump to the vacuum vessel are equipped with gold *O*-ring flange seals. For initial C-Stellarator operation, one pumping system is connected directly to the vacuum vessel (Figs. 1, 4). Later, two of these pumping systems, including two bakeable high-vacuum valves, will be connected to the divertor to form the complete vacuum-pumping system.

Divertor

The divertor is a magnetic ion separator designed to have high conductance. This unit separates out heavy ions and ions on the outside surface of the plasma and focuses them into the vacuum-pumping system (Fig. 5). Thus, the divertor provides a limit to the diameter of the remaining plasma by taking away ions from the outside edge of the plasma. The magnetic coils in the divertor provide a divergent magnetic field to produce the ion separation. The shape of the outside of the divertor is designed to minimize deformation from vacuum loading during the long 450°C baking period. The divertor has a number of large welded

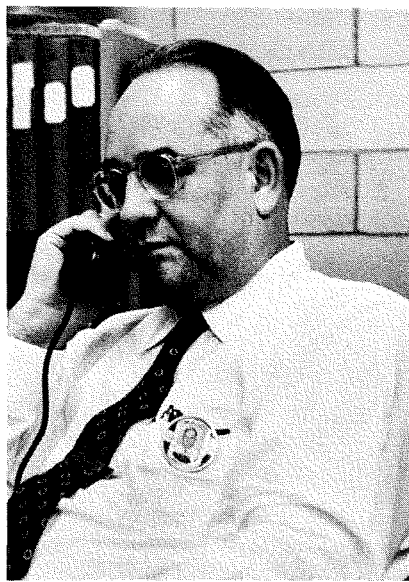

DR. LEWIS B. HEADRICK received the B.S. in Physics in 1926 from the University of Chattanooga, and continued his graduate education at the University of Michigan, where he received the M.S. in Physics in 1928 and Ph.D. in Physics in 1930. In 1930, Dr. Headrick joined the Western Electric Company as a cable development engineer. In 1931, he joined RCA at Harrison. Between 1931 and 1953 he was engaged in cathode-ray and camera-tube development for the Electron Tube Division in Harrison and later in Lancaster where, in 1943, he was appointed Manager of that activity. In 1953 he was appointed Staff Engineer in the RCA Electron Tube Division at Lancaster. In 1958 he was appointed Staff Engineer of C-Stellarator Associates at Princeton. Since 1959 he has been Staff Engineer in High Power Microwave Engineering of the RCA Industrial Tube Div. at Princeton, N. J. Dr. Headrick is a Fellow of the IRE and of the Society for Advancement of Management. He is also a member of Sigma Pi Sigma, Sigma Xi, the American Association for the Advancement of Science, and the American Physical Society.

joints (from about 20 inches to 80 inches in diameter) to allow for assembly of the coils.

The performance of the divertor is one of the most important features of the C-Stellarator—equal in importance to the containing magnetic field and the plasma heating—because the divertor must keep the plasma at the extremely high purity level required to maintain the high temperature necessary for hydrogen fusion. Impurities within the deuterium fuel (that is, heavy ions of the order of 1 part in 10 million) may cause detrimental cooling of the plasma. Impurity gases of heavy ions are liberated from the vessel walls by high-velocity ions from the plasma and must be directed into the pumping system before they diffuse into the hot plasma and cool it by their energy absorption and radiation capabilities. The divertor is one of the major components which will be added to the C-Stellarator after its initial operation.

Diagnostic Ports

The vacuum vessel contains six port cross-sections which accommodate windows of several different types for

various diagnostic measurements. Glass windows are used for optical observations and visible spectra, and sapphire windows for ultra-violet spectra down to about 1600 angstroms. A vacuum spectrograph for observation of far-ultra violet spectra down to a few hundred angstroms can be connected to the vacuum vessel in place of one of the demountable ports.

There are six cross ports which have four openings each for windows. These openings are at 90° angles with respect to each other for observations across the plasma in two directions. (Fig. 1). Nearly the entire 8-inch inside diameter of the vessel, can be viewed.

In addition to these cross ports, which are designed for transmission and absorption measurements as well as for direct viewing, two observation ports containing sapphire windows are located in the *U*-bends for axial observation of the plasma in one of the straight sides of the vacuum vessel. Provision is made for microwave pickup, transmission, and absorption of the plasma at another location on one of the straight sides. The study of microwave properties of the plasma is expected to yield a major part of the diagnostic information—particularly the plasma density, and information such as temperature, r-f energy output, electron and ion resonant frequencies, and noise spectrum of the plasma.

POWER SUPPLIES

The power supplies with their controls and distribution systems may be considered in two parts: the 60-cycle a-c substation, and the motor generators that convert a significant part of the a-c power to d-c for magnetic containment.

The 60-cycle substation has two main supply lines having continuous ratings of 132 kv at 50 Mva and 26 kv at 5 Mva. A stand-by emergency diesel-operated 480-volt generator has a continuous rating of 0.3 Mva. A battery-operated control-switch gear automatically switches from the large to the intermediate to the emergency power supply, with corresponding load changes, in case of power failure. The emergency unit supplies power for the vacuum pumps, emergency lights, etc.

There are four sets of motor generators (Fig. 6). Three consist of four d-c generators having a continuous rating of 4,060 kw driven by a 7,000-hp. motor. The fourth set employs a 1,500-hp motor to drive a 1,090 kw d-c generator. The pulse rating of each main motor-generator set is 66,700 kw (750 volts at 89,500 amperes) at 350 rpm at the start of a pulse and 280 rpm at the end of the pulse, for a duty cycle of 5.15 percent.

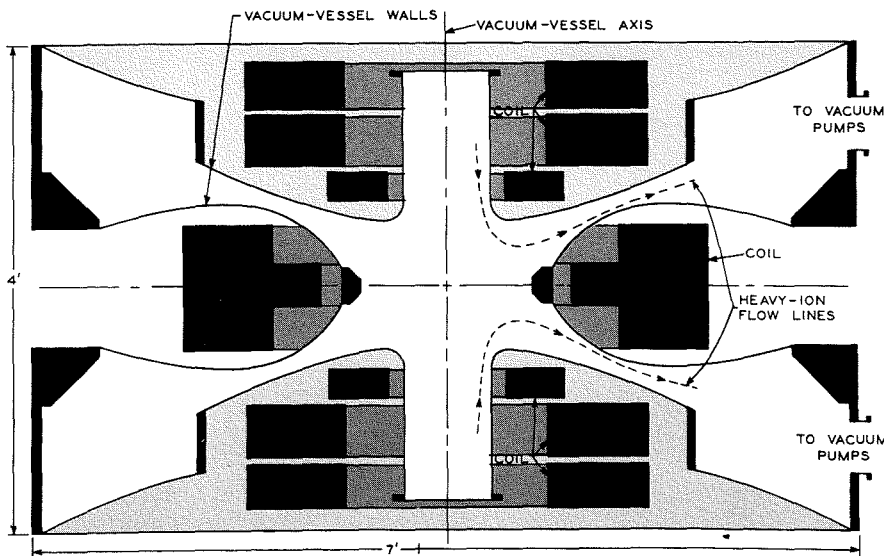
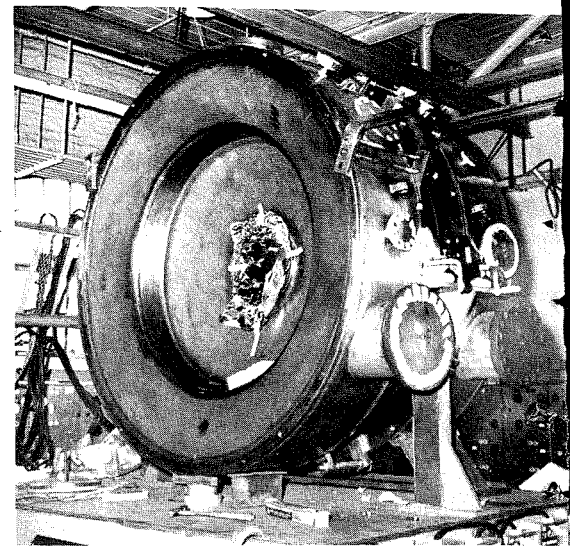

Fig. 5—The divertor, a magnetic ion separator, which will be added to the C-Stellarator after its initial operation phase. Its important function will be to separate heavy-ion impurities, preventing them from detrimentally cooling the plasma. Photo shows the divertor under test at

Lancaster; diagram is a section through a horizontal plane illustrating how a divergent magnetic field diverts the heavy ions to the vacuum pumping system.



Each main motor-generator set has a flywheel which weighs 96 tons and is 20 feet in diameter. When operated between 350 and 280 rpm, the three flywheels supply 95 percent of the energy for the 200 Mw pulse. The three motors, which have a combined rating of 21,000 hp, supply all of the operating losses and only about 5 percent of the pulse power. A liquid rheostat regulates each 7,000-hp motor load to 100 percent during the pulse operation.

The four generators of one main set, although driven by a 7,000-hp motor, have a much higher continuous rated capacity than a 7,000-hp motor can produce. When higher continuous power is needed, the 7,000-hp motors can be readily replaced with 25,000-hp motors. These large motor-generator sets supply a current of 44,600 amperes for the 55,000-gauss containment field.

The 1,500-hp motor drives a d-c generator with a 1,090 kw continuous rating and a 4,200 kw pulse rating for a 5.15 percent duty cycle. This motor-generator set supplies 11,150 amperes of current to the stabilizing coils. The flywheel is about one-quarter the size of the large ones. This smaller motor-generator set can be replaced by one of the large motor-generator sets with a 7,000-hp or 25,000-hp motor when still more d-c power is needed.

MECHANICAL STRUCTURE

A massive structure is required to support the total 280,000-pound load of coils, transformers, vacuum vessel, and other gear. This structure, consisting of about 365,000 pounds of type 305 non-magnetic stainless steel, is 30 feet long, 13½ feet wide, and about 11½ feet high.

In addition to being nonmagnetic, the structure must be very stable and provide rigid support for many different parts subjected to enormous forces of the order of 3×10^6 pounds during pulse operation. These forces produce maximum deflections of only about 1/16 inch. For increased stability, all parts of the structure are fully annealed; because this process limits their tensile strength to moderate values, heavy structural members are required.

ACKNOWLEDGEMENT

The design of the C-Stellarator was done by many people in C-Stellarator Associates, Allis Chalmers, and RCA. The basic specifications and performance requirements were prepared by the Matterhorn Project Group. Thus, the C-Stellarator is the result of a major cooperative effort.

The author wishes to acknowledge the cooperation of all the groups involved, and, in particular, the support of Dr. Lyman Spitzer, Jr., Matterhorn Project Director; L. J. Linde (Allis Chalmers), Director of C-Stellarator

Associates; D. F. Schmit (RCA, Vice President, Product Engineering), Senior RCA Representative to C-Stellarator Associates; and Dr. P. T. Smith (RCA) and D. Scag (Allis-Chalmers), Technical Directors of C-Stellarator Associates.

BIBLIOGRAPHY

1. Lyman Spitzer, Jr., "The Stellarator," *Scientific American*, Vol. 199, No. 4, p. 28; October 1958.
2. Robert A. Ellis, Jr., "Stellarator," *Princeton Alumni Weekly*, Vol. LIX, No. 1, p. 6; September 19, 1958.
3. *Project Sherwood—The U.S. Program in Controlled Fusion*; Amasa Bishop Addison-Wesley Publishing Co., Inc.; 1958.
4. George Warfield, "Controlled Thermonuclear Fusion—Promise of the Future," *RCA Review*, Vol. XIX, No. 2, p. 137; June 1958.
5. P. T. Smith, "Controlled Thermonuclear Fusion," *RCA Engineer*, Vol. 4, No. 5; Feb.-Mar. 1959.
6. E. W. Herold, "Controlled Thermonuclear Fusion—Its Meaning to the Radio and Electronic Engineer," *RCA Review*, Vol. XIX, No. 2, p. 162; June 19, 1958.
7. J. Q. Lawson, "The Model C Stellarator," *RCA Engineer*, Vol. 4, No. 5; Feb.-Mar. 1959.

Fig. 6—A view of half the motor-generator room; the other half (out of the photo to the right) contains a similar motor-generator line-up.

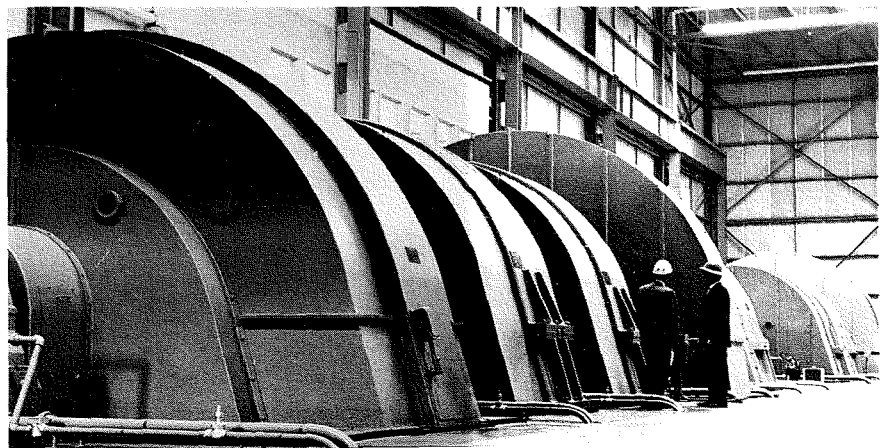

DATA HANDLING FOR THE C-STELLARATOR

by

A. S. BUCHMAN

*Electronic Data Processing Division
IEP, Natick, Mass.*

and

R. T. ROSS

*Broadcast and TV Equipment Division
IEP, Camden, N. J.*

THE C-STELLARATOR will produce a vast amount of diagnostic data each time it is operated. In general, the transducers produce signals (single-valued functions of time) which are of a few milliseconds duration, are non-repetitive, and may contain significant information in the megacycle region. There is no simple means available for accurately recording such information; nonetheless, the data must be collected and stored in an orderly fashion. Further, because of the inherent flexibility built into the C-Stellarator installation, hundreds of machine settings must also be recorded to validate and identify the diagnostic data. Because of the complexity of the situation, an extensive study was undertaken to 1) determine the needs for a data system; 2) define the characteristics of such a system; and 3) synthesize several suitable systems which could be compared on the basis of cost, operating characteristics, and ease of use.

A data system (Fig. 1) has been installed that is presently adequate for data acquisition and transmission. However, it may become inadequate for data recording, reduction, and processing, if a huge volume of usable data is generated. In anticipation of this, the detailed advance-system study was conducted of equipment and techniques which might lead to the synthesis of an automatic data-handling system.

STUDY OF PRESENT AND FUTURE REQUIREMENTS

A central study group was organized in the Electronic Data Processing Division, IEP, Camden. Because of the variety of skills called for, permanent members of the study group were also assigned from other RCA divisions. This central group worked in close cooperation with Matterhorn scientists, with other RCA divisions, and with outside suppliers. At Matterhorn, they investigated the nature of the signals generated by various transducers, the stability of the basic sensors, the accuracy of the data, the use to which the data is put, and the type of calculations and analysis which might be performed.

The data gathered from this study was used as a background in creating tentative specifications for a data-handling system. Several different approaches to implementing the system were analyzed and expert consultants were called in from many other divi-

sions of RCA to contribute information on specific components.

In cooperation with a Matterhorn review group, final specifications were created for different systems, each of which could satisfy large parts or all of the specifications. The most suitable of the systems were rigorously compared on the bases of performance and cost.

CONCEPTS FOR DATA-HANDLING SYSTEMS

The initial aspect of the study confirmed the impression that the current means of data recording, storage, and retrieval could become inadequate for the C-Stellarator. It was further shown that a proper data system could under some circumstances actually reduce test times and the number of tests to be performed. In addition, a retrieval system could open the door to entirely new means of data analysis which might enhance the value of the C-Stellarator facility.

The second conclusion was that it is neither feasible nor desirable to collect all of the information available, nor to store all of it in complete content. Collection of all the output data from the machine would tend to obscure valuable facts in the sheer bulk of information accumulated. It was determined that the data which should be collected is that which is primarily routine in nature. This is the information which indicates the state of the

A. S. BUCHMAN graduated from Cornell University in 1948 with a B.S. in Mechanical and Industrial Engineering. Prior to joining RCA, he was with the Shallcross Manufacturing Company, in the design of industrial automation systems, and then by the Ford Instrument Company, on control systems and analog computers. At RCA, he has been instrumental in the development of air-borne reconnaissance systems and has been project engineer on optical, electronic, and ultrasonic techniques for process control and inspection. He participated in the data system study of Matterhorn and wrote the final report on the study. Today, Mr. Buchman is Leader, Design and Development Engineers, in the EDP Industrial Computer Systems Department.

machine during the test and the most common diagnostic data outputs. This data is easily overlooked by the experimenter in his intensity of concentration on a particular phenomenon, and is the very data needed to corroborate the validity of the experiment.

It was further decided that the collected data could be recorded automatically without interfering with the normal operation of the machine or with the scientists working on the machine. This collected data could be automatically classified, reduced, and filed in a library-type system from which it could be recalled on demand.

The last conclusion was that a suitable library-type system could be implemented in two different, but desirable ways. These systems were profoundly different in the hardware required and in their functional performance. But each of them, in its own way, was a satisfactory data system.

RECOMMENDATIONS FOR ADVANCED SYSTEMS

A photographic system and a digital system were the two recommended.

In the photographic system (Fig. 2), incoming information is recorded by two different cameras photographing high-resolution cathode ray tubes. The first film is processed in a fully automatic, high-speed, rapid-developing machine that produces a slide showing all of the traces for a particular shot. This slide could be immediately projected and viewed, or copied by a high-speed printer. The second film is developed in the laboratory and provides an archival-quality record which is stored on a reel of film which can be used in an automatic scanner to recall recorded information. An optical

R. T. ROSS graduated New York University in 1943 with degree of Bachelor of Electrical Engineering. He served in the U. S. Army Signal Corps as a radar officer until September 1946. He joined RCA in January 1947, as a design engineer in the terminal group of Industrial Electronic Products. Recently he joined the systems engineering activity of the Closed Circuit Television Systems group, IEP Broadcast and TV Division. Mr. Ross is a member of Eta Kappa Nu.



A. S. Buchman (l.) and R. T. Ross.

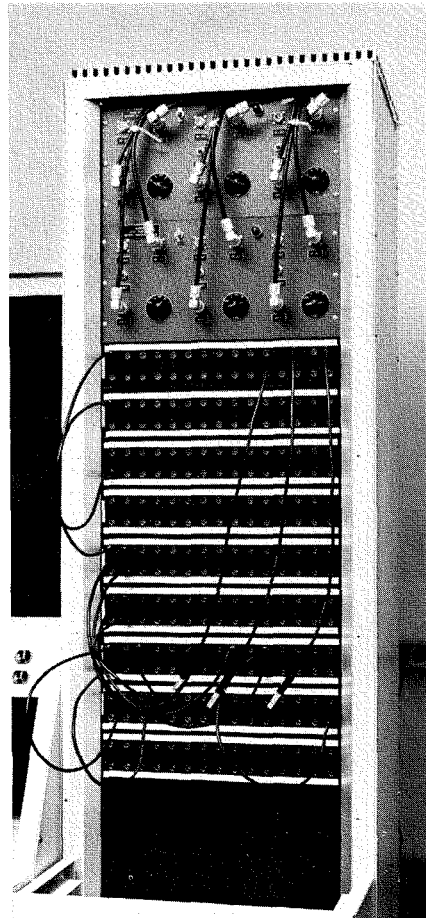
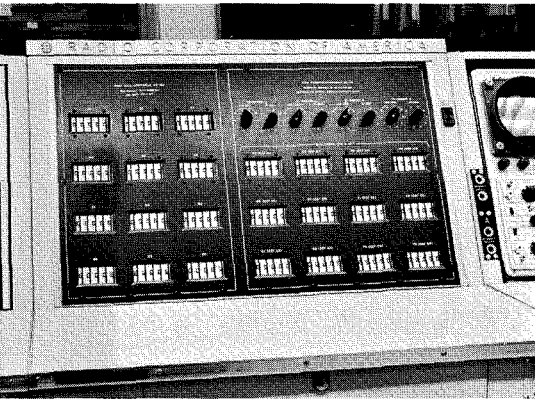
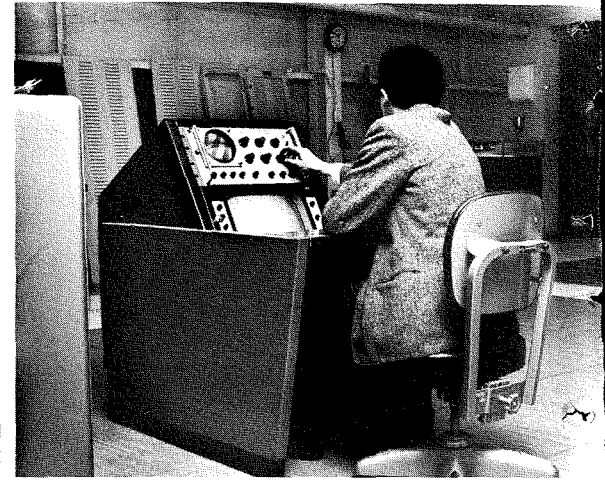

Fig. 1—Present C-Stellarator data system. a. (above) Modular data system consoles in the C-Stellarator central control room. Arrow indicates director's monitoring position. Windows behind the consoles overlook the C-Stellarator itself (see front cover, extreme right). b. (left) Data timer control console. c. (lower left) Data patch board. d. (above, right) TV system monitoring console, also located in the central control room.

curve reader and analog-to-digital converter utilizing fiber optics produces punched-paper-tape transcriptions of any desired curve. This information can be used in an off-line computer for extensive analysis. The usefulness of this installation is considerably enhanced through the addition of a high-speed magnetic-drum recording of the incoming information. The recording technique utilizes a double-side band FM modulation, heterodyned to bring the high-frequency information within the frequency recording spectrum of the drum. This system permits continuous viewing of transient phenomena and allows the operator to select special curves, or sections of curves, for photographic recording. By this means, the inherent resolution limitation of cathode ray tubes is overcome.

In the digital system (Fig. 3), a special high-speed analog-to-digital converter was devised to operate at the required resolution at a rate of 1,000,000 conversions/second. Special non-linear features are built into the converter to compensate for errors of dynamic range and to allow the computer to correct such errors. The digitized information is stored on a magnetic drum where recirculating tracks are used to sample the information at a frequency suitable for recording on tape stations. The recorded information can be analyzed and converted into engineering units and the tapes may be edited for use on an off-line scientific computer. The stored data may be printed out using various compression techniques, and an application of Electrofax type techniques allows rapid retrieval of the information in the form of analog curves.

IMPLEMENTATION OF PRESENT DATA SYSTEM

The data-system study produced sophisticated system concepts realizable within the present state of the art. However, their ultimate implementation requires time and effort which must presently be directed toward feasibility-testing the C-Stellarator itself. Therefore, a more-limited data system has been installed (Fig. 1). It has five main functions: *acquisition, transmission, recording, reduction, and processing.*

Data Acquisition

The data-acquisition equipment (for plasma diagnosis) is being supplied by Project Matterhorn scientists, with RCA personnel and equipment not directly involved. However, the transducers used here will generally supply electric signals as single-valued functions of time proportional to the quantity being measured.

Transmission System

Coaxial cable of 75- or 180-ohm impedance is used for transmission of the data signals from the C-Stellarator to the central control room, since the data signals are assumed to contain frequencies from d-c to 10 Mc, initially, and perhaps as high as 50 Mc in later stages of operation. Accordingly, the design goal for the transmission system was set at 3 db down at 100 Mc. To achieve this, and to avoid the necessity of changing cables or connectors should these higher frequencies become significant in the future, 75-ohm, constant-impedance, type-C connectors are being used with double-shielded (for minimum pickup of r-f frequencies) 100-percent-sweep-tested coaxial cable.

The diagnostic devices are connected with coaxial cables to one of four patch boards located at the C-Stellarator from where they are cabled to a data patch board in the central control room. Cables connecting the various patch boards are of equal length thus making all data transmitting paths identical in electrical performance once they have been calibrated. Patching of data lines from the C-Stellarator to the recording station is accomplished at the data patch board.

Recording Equipment

The recording equipment consists of dual-beam oscilloscopes, equipped with Polaroid cameras and mounted in consoles of modular design (Fig. 1a). This system of recording was used on earlier model Stellarators and, although its data-handling ability is limited, it is regarded as adequate for the initial operation of the C-Stellarator and can be supplemented by an automatic data-handling system if experimental results indicate this need.

To aid the director of the experiments, a monitoring position has been provided containing two dual-beam oscilloscopes and patch boards (Fig. 1a). All recording oscilloscope inputs are multiple-connected to the director's patch board through constant-impedance (to 10 Mc) networks. The signals will be attenuated about 1 db per network, but are otherwise unaffected. Direct tie lines (no networks) between the data patch board (Fig. 1c) and the director's patch board make it possible to record at the director's station with minimum signal attenuation.

Pulses to trigger the recording oscilloscopes at the recording stations and to provide certain *start* and *stop* signals are obtained from the equipment action sequence timer [See P. Slavin, this issue.] For the data systems, the occurrence times of these pulses are controlled by setting thumb-wheel switches

at the data timer control console (Fig. 1b).

Grounding and Shielding

In anticipation of r-f pickup problems, a copper ground plane (insulated from building steel) has been provided in the central control room floor, and provision has been made for the addition of a screen room if necessary. All control cables entering the central control room are shielded with a lap-wound solid copper tape, grounded only at the Stellarator. The control room consoles and floor are grounded to building steel at one point only, with a removable ground for personnel safety, but insulated from the ground plane. Coaxial lines are isolated from ground throughout while the oscilloscopes are grounded to the front of the consoles with removable grounds. Cables entering central control are run in steel-covered ducts.

The kick space of each console and rack module contains an RCA electro-luminescent light panel (yellow-green light) which provides a soft glow to illuminate, without glare, the edges of the furniture during an experiment, when the room is generally blacked-out.

Display and Communications

Supplementing the data system itself are a closed-circuit tv system and a communications system. The tv system was provided to perform supervisory and surveillance functions (Fig. 1d), and was designed to be used as an engineering tool. The high (60-kv) voltages encountered at the C-Stellarator make it necessary to provide double isolation on all instrumentation leads where the meters are located outside the C-Stellarator room, as in the central control room.

Since the Stellarator project is experimental in nature, it is anticipated that there will be continuous changes in the instrumentation. The tv system eliminates the expense and trouble of bringing temporary instrumentation to

the central control room with double isolation. The RCA TK-21B vidicon camera was selected to obtain usable pictures under the poor lighting conditions expected. The incident light measured on vertical wall surfaces varies from about 5 to 45 foot-candles. With this system, it is possible to read the smallest division on a temperature gauge with a 4-inch dial and a panel-type voltmeter with a 3½-inch scale, when the camera is 5 feet away and looking through a leaded-glass window, on the outside of which the incident light is 8 foot-candles. For maximum flexibility and convenience, the camera is equipped with remote-controlled pan, tilt, zoom, iris, and focus, and with a 300-foot camera cable. For protection against magnetic fields, it is enclosed in a special shielding enclosure. For initial operations, the camera is mounted such that the operator has a clear view of both sides of the C-Stellarator. This permits surveillance for personnel safety (prior to starting an experiment), breaks in water lines, arc-over, etc.

Communications at the C-Stellarator facility consist of an operator's headset system and a sound-powered (but polarized for possible future battery operation) phone system. The headset system permits communications between the director and recording personnel during an experiment. The sound-powered system is used for installation and trouble-shooting.

ACKNOWLEDGMENTS

Installation and test of the data system equipment was under the supervision of RCA Service Company engineers A. W. Martin and T. R. Wylie.

The authors would like to acknowledge the major contributions of B. R. Clay and Dr. A. Harel of the IEP Electronic Data Processing Division; and of W. L. Hurford of Broadcast Systems Engineering, who were members of the advanced system study team.

Fig. 2—Concept of an advanced photographic data system.

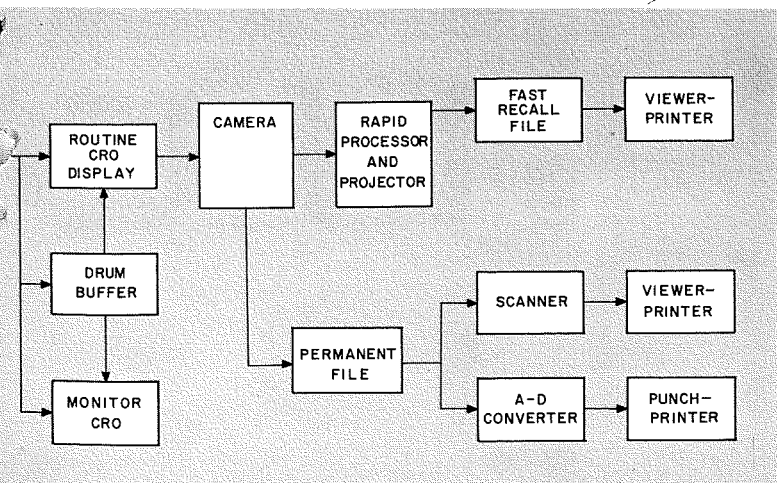
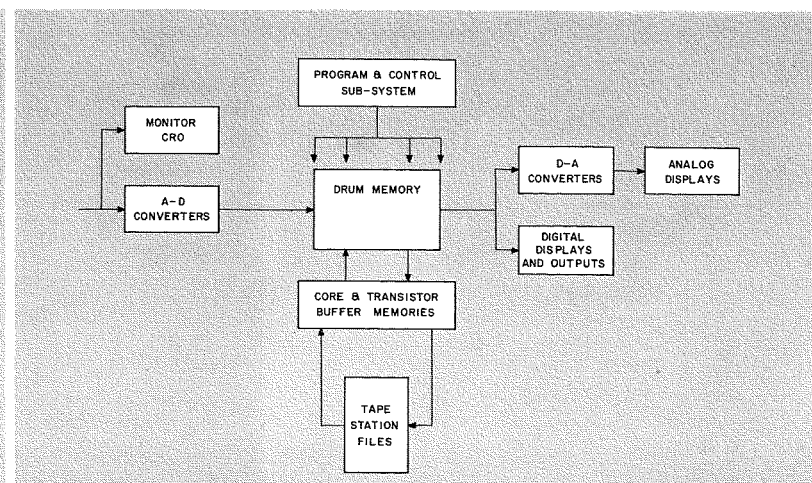

Fig. 3—Concept of an advanced digital data system.



ULTRA-HIGH-VACUUM

... C-Stellarator System Involves Advanced Techniques

by K. DREYER and J. T. MARK

Electron Tube Division

Lancaster, Pa.

AN ULTRA-HIGH VACUUM has been defined by the American Vacuum Society as the range of pressures below 10^{-9} mm-Hg. Under laboratory conditions and in small volumes, such degrees of vacuum are not new; vacuum apparatus¹ used by Langmuir in 1929 complied with today's best practice and undoubtedly achieved that range. In addition, pressures below 10^{-9} , in small volumes, have probably been achieved many times in RCA tube manufacture.

However, the ultra-high-vacuum requirements of the C-Stellarator posed an engineering challenge—a vacuum of 2×10^{-10} mm-Hg must be maintained in a stainless-steel vessel with a volume in excess of 25,000 cubic inches, whose configuration is greatly complicated by many diagnostic ports and other attachments required in experiments on the high-temperature plasma magnetically confined therein. In a volume the size of the C-Stellarator, a vacuum of 3×10^{-8} would have been a significant accomplishment; the successful design of this system thus represents an engineering achievement of around two orders of magnitude.

Extensive engineering development and tests of smaller systems in a vacuum test facility^{3,4} were carried out to determine how to scale them up to the size required for the C-Stellarator. This article will describe the C-Stellarator vacuum system, and will cover some key engineering techniques for successful design of ultra-high-vacuum systems.

C-STELLARATOR VACUUM REQUIREMENTS

The design specifications for the C-Stellarator vacuum system, established by Dr. D. J. Grove, R. Clary, and R. Rosen of Project Matterhorn, Princeton University, were in general as follows:

The system must be capable of ultra-high vacuum with a base pressure of 2×10^{-10} mm-Hg, with the pumping system capable of exhausting dosages of experimental gases at pressures of 10 microns or less without detrimental effect to the base vacuum or system cleanliness.

The vacuum system had to be built in

two phases. Phase A, with its pumping speed of 150 liters/sec (utilizing one pump system), has a Stellarator tube, or vacuum vessel, for plasma containment. Phase B, with its pumping speed of 1500 liters/sec (utilizing two pump systems), has a vacuum vessel, and a *diverter* (a device for separation of heavy-ions to prevent detrimental cooling of the plasma). The Phase-A system, (now being installed) will be used in preliminary Stellarator experiments. The Phase-B system, to be installed later, is now undergoing engineering tests at Lancaster.

The vacuum system required nonmagnetic, 305-type stainless steel, with demountable, corner-type, gold-seal flanges. The entire vessel and pumping system must be capable of numerous reliable baking cycles at temperatures up to 450°C. The system also requires a suitable bakeable valve to permit isolation of the Stellarator vessel from the pumping system.

PHASE-A VACUUM SYSTEM

The C-Stellarator vacuum vessel is made of 8-inch-diameter, type-305 stainless-steel welded tubing (Fig. 1). Center-line-to-center-line distances of the oval are 86 inches across the width and 187½ inches across the length. The vessel has eighteen 8-inch-diameter double-corner, gold-seal, demountable flanges; four bellows-type expansion joints; one 8-inch-diameter, 12-inch-long ceramic insulating section²; and 33 observation windows (Fig. 2) of glass or sapphire,²

which also have gold-seal flanges. The entire vessel is insulated for 11,000 volts from ground potential. The vessel has a volume of about 500 liters and a surface area of about 87,000 cm.²

Table I shows the forces required on the bolts to make the vacuum seal on the double gold-seal flanges (Fig. 3). The flanges are machined forgings of type-305 stainless steel with A286 metal bolts. The bolts are generally 1-inch-long, ¼-inch-diameter, 28-tpi socket-head screws spaced on ¾-inch centers.

Pumping System

The 150-liter/sec Phase A pumping system³ stands 16 feet above floor level (Fig. 4); it is assembled with 13 corner gold seals, eight having a diameter of 8 inches, two a diameter of 14 inches, and three a diameter of 2 inches. A total of 69 gold seals are used in the entire system, with a total lineal gold-seal surface of 1179 inches.

Vacuum Valve

The large bakeable valve (Fig. 5) has an opening of 8 inches and a conductance of approximately 2000 liters/sec. It is built into a standard 12-inch stainless-steel *T*, and employs a 50-square-inch, 5000-pound hydraulic cylinder for its closing force. It should be capable of at least 200 operations, and has shown a closed leakage of less than 5×10^{-8} standard-atmosphere cm³/sec for each closing.

A novel feature of this valve is its ability to form a new seal at each closing, if the operator so desires (Fig. 5). The valve nose or plug is of OFHC copper, and the seat of stainless steel. The valve is equipped with automatic operat-

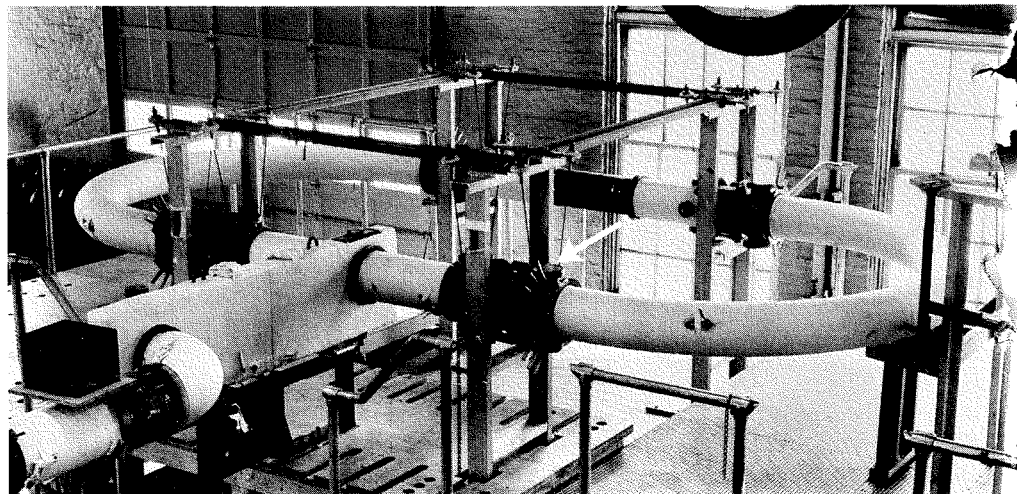

Fig. 1—The vacuum vessel during engineering tests at Lancaster. Junction between the pump box and vessel is at lower-left center. Note suspension system to allow for thermal excursions during bakeout. Arrow indicates a pair of the observation ports. Dark section on the far side is the ceramic insulating section. (Also see Headrick, Fig. 1, this issue.)

ing-control apparatus and with push buttons for remote, manual operation. In the event of power failure to the hydraulic pump motor, high-pressure nitrogen (stored in cylinders) can actuate the valve.

System Bakeout

Because each flange, observation window, and section of tubing must be maintained within 25°C of the desired bakeout temperature, 126 separate heater units are required to bake the vessel and pumping system (Fig. 6). Each heater circuit has its own temperature controller, and each controller is monitored by a temperature recorder. Each bakeout through 450°C requires approximately four days. The vessel components and traps are raised to 450°C in precise 25-°C increments and are held at 450°C for 18 hours. The vessel pressure at 450°C, with one trap cold, is 10^{-6} mm-Hg.

Vacuum-System Suspension

The entire vacuum vessel is mechanically secured to the C-Stellarator base at only one point, the pump box. Although the vessel will be ultimately suspended within the Stellarator coils, suspension was provided during initial assembly and tests by six sets of electrically insulated, spring-loaded stainless-steel wire-rope slings (Fig. 1) capable of handling the thermal expansions incident to the bakeout excursions. Measured expansion along the major axis during engineering tests reached 1.2 inches at maximum temperature, while the width increased 0.720 inch.

In the C-Stellarator installation (Fig. 6) the suspended pumping system of valve, traps, and diffusion pump rests upon its framework flexibly by a system of rollers, to permit lateral movement, and on six-spring cushioning platforms.

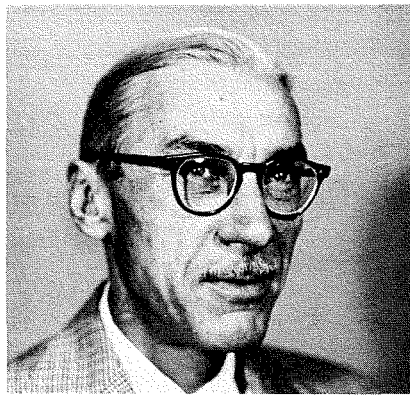

KARL DREYER received his BS from the Cooper Union in 1929 and the graduate degree of Chemical Engineer in 1934. He joined RCA at Harrison, N. J. as a receiving-tube development engineer in 1929. During 1944 and 1945, he was assigned to the RCA International Division. In 1946, he transferred to the Lancaster plant. He is currently Senior Engineer in the Vacuum Engineering Dept. at Lancaster. His major assignment is responsibility for engineering the vacuum vessels for both Phase A and B of the C-Stellarator. He is a Senior Member of the IRE, and a Member of the American Vacuum Society.

Divertor Simulation

To simulate the divertor and study the plasma in the Phase-A system, the pump box contains two *aperture limiters* of different sizes. These molybdenum limiters are interchangeable and replaceable through a gold-sealed orifice, and feature externally operated adjusting devices for both diameter selection and position selection to facilitate studies of plasma configuration at this point. The molybdenum and sapphire nonlubricated bearings of the limiter assembly are novel in that they allow easy manipulation in high vacuum after the 450°C bakeout. A smaller vacuum system, the gas-injection system, is located adjacent to the main tube and is used to mix and insert experimental gases.

Assembly and Test

Component parts for the Phase-A system were assembled by inert-arc-fusion welding to full penetration, allowing no cracks or crevices in the high-vacuum side of the weld. All metal surfaces were



JOHN T. MARK received his BSEE from Valparaiso Technical Institute in 1950. Prior to that time, he had served with the Army Airways Communications System during World War II, and worked for Sylvania Electric Products, Inc., and several radio broadcast stations. He joined the RCA Electron Tube Division at Lancaster, Pa., in 1950, and is presently working on the design and construction of the vacuum systems for the C-Stellarator. He is a Member of the IRE, the IRE Professional Group on Electron Devices, and the American Vacuum Society.

machined to a No. 4 finish or better. The parts were washed prior to assembly in hot water and a strong household detergent, rinsed thoroughly in hot tap water, rinsed in hot distilled water, and then dried with chemically pure acetone. No commercial degreasing agents were used, and wherever possible, machining was done dry without the use of cutting oils.

After assembly and leak-checking with a helium mass spectrometer, the welds were dry-hydrogen fired at 1100°C, then leak-checked again to detect any possible leaks that may have developed as a result of burnout impurities or contaminations. The vessel was not considered leak-tight until the entire system, with the exception of the forepump, could be held at vacuum by the leak-checker with its pump throttled while sections of the machine were "bagged" with sheet rubber, flushed with helium, and allowed to remain flushed for a period of five minutes.

It was also found necessary to leak-check periodically while the system was being baked. Because the basic sensitivity of most commercially available leak detectors is only 10^{-9} standard cm^3/sec , even one such leak would be intolerable and prevent reaching an ultra-high vacuum. In checking, it was assumed that every seal leaks to some degree, and that the total amount of these leaks must be no greater than the pump "throughput" at 10^{-10} mm-Hg pressure.

This system was then subjected to twelve bakeout excursions from room temperature to 450°C, and then operated at 3×10^{-10} mm-Hg for thirty days before it was disassembled and shipped to the C-Stellarator facility in Princeton, where it is now being installed (see cover).

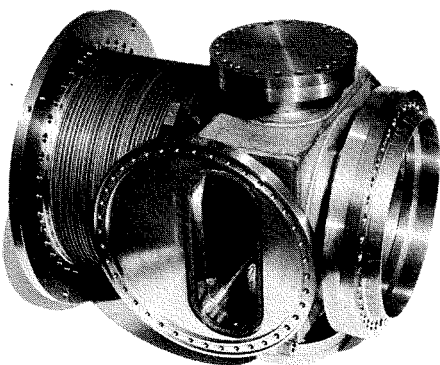

Fig. 2—One type of observation port.

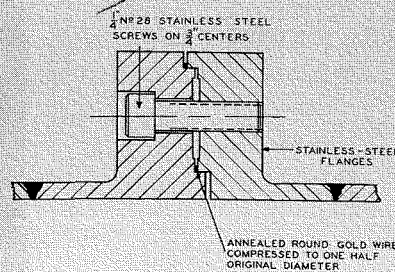

Fig. 3—Double-gold-seal flange.

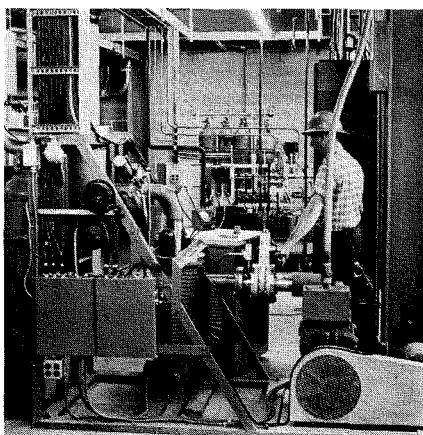
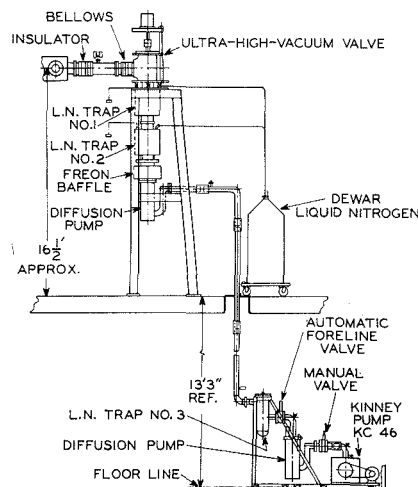
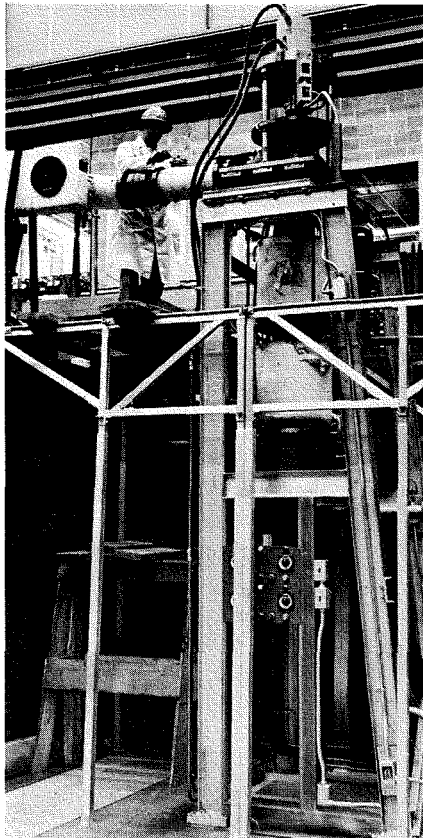

Fig. 4—Top: Upper portion of actual C-Stellarator Phase A pumping system; pump box leading to vacuum vessel is at left of man. Center: Schematic of Phase A pumping system. Bottom: Lower portion of pumping system.

ENGINEERING TECHNIQUES

In the course of developing and constructing an ultra-high-vacuum system like that just described for the C-Stellarator, certain engineering techniques are of particular significance in achieving and maintaining the ultra-high vacuum. Some of the more important of these are presented here.

Vacuum and Ionization Gauging

New advances have been made in the method of vacuum gauging and the development of reasonably accurate ionization gauges capable of indicating pressures of 5×10^{-11} mm-Hg and less. These gauges make it possible for experimenters to observe the results of various techniques for obtaining and maintaining an ultra-high vacuum.

A Bayard-Alpert ionization gauge,⁵ or the equivalent, is appropriate for measuring the vacuum-system pressure. During development of this gauge, Bayard and Alpert discovered that the lowest accurate reading of the more-conventional vacuum ionization gauges is limited to 10^{-8} mm-Hg because of the soft X-rays generated at the ion-gauge grid. When these soft X-rays bombard the collector and cause it to emit electrons, a collector current flow is created that is independent of pressure. In an ionization gauge, free nonionized or neutral gas is positively ionized by the electron stream traveling from the negatively charged cathode to the positively charged grid. The positively charged gas ions are then collected by the negatively charged collector. A positive gas ion drawn to the negative collector accepts an electron from the collector and again becomes a free, uncharged molecule. The flow of electrons to the collector, when metered, describes the degree of vacuum in the gauge and in the vacuum system. X-ray bombardment, therefore, produces the same effect as gas ions in that a collector current is caused to flow.

Some physicists were aware of the

X-ray condition (Dushman, Nottingham, Bayard, Alpert, and others), but Alpert was the first to design a simple gauge which minimized this problem. (Nottingham, at Massachusetts Institute of Technology, made some gauges which functioned well, but they were rather complicated.)

Bayard and his associate Alpert designed and constructed an ion gauge in which a fine collector wire (0.001 inch in diameter or smaller) is located on the axis of a typical cylindrical, wire-wound grid cage. A filamentary cathode is suspended outside the grid cage (Fig. 7). The use of the very small collector reduces the X-ray cross section and thereby reduces the collector's x-ray-induced electron-emission level. Because the ion-gauge collector is metered at very small currents, it is essential that all precautions be taken to eliminate any electrical leakage that might mask the vacuum readings. The use of an ion gauge of this type permits the reading of vacuum at pressures as low as 5×10^{-11} mm-Hg.

Construction Materials

Only nonhygroscopic materials having low vapor pressures should be used in an ultra-high-vacuum system. A good practice is to use materials considered satisfactory for vacuum-tube design. Before a tube is sealed, the remaining residual gases in the vacuum are common to the tube and its vacuum pumping system, and therefore, the tube pressure can not be lower than the highest vapor pressure materials in the system. The use of any material having a vapor pressure greater than that of silver should be avoided.

Leak Detection

The vacuum system must be free of all leaks detectable with the most sensitive helium-mass-spectrometer leak detector. The detector should hold a vacuum on the system by means of its own internal pumping system, with no auxiliary

TABLE I — SUMMARY OF DATA ON GOLD VACUUM-SEAL COMPRESSION TEST

Type of Compression Seal	Gasket Diameter, Inches	Compressed Diameter, Inches	Radial Clearance, Inches	Force Required For Compression, Pounds/Inch	Stress Per Bolt On Standard Seal Ring (1/4-28 Bolt), Pounds/Square Inch
flat	0.020	0.010	—	795	15,600
flat	0.020	0.008	—	1,240	24,300
flat	0.030	0.010	—	1,520	29,900
flat	0.030	0.008	—	3,650	72,000
corner	0.020	0.010	0.001	1,395	27,500
corner	0.020	0.008	0.001	2,150	42,500
corner	0.020	0.010	0.002	857	16,900
corner	0.020	0.008	0.002	1,430	28,300
corner	0.020	0.010	0.005	704	13,850
corner	0.020	0.008	0.005	1,135	22,400
corner	0.030	0.015	0.002	1,470	29,000
corner	0.030	0.012	0.002	2,360	46,600
corner	0.030	0.015	0.004	1,100	29,000
corner	0.030	0.012	0.004	1,770	46,500
corner	0.030	0.015	0.005	1,275	25,050
corner	0.030	0.012	0.005	2,000	39,500

NOTE: All gaskets annealed at 600° C in air for one hour.

pumps in use that may otherwise reduce detection sensitivity.

It is good practice to connect the leak detector to the fore-vacuum line of the system between the diffusion pump and mechanical forepump. If the system is tight and there is no gas leakage, any commercial detector will serve as a fore-pump. Vessels having volumes as large as 1500 liters have been tested in this manner. With systems of large volume, probe checking must be accomplished very slowly to allow helium to accumulate in the system.

Leak detecting by *bag checking* is preferable on large-volume systems. This involves holding a plastic bag over parts or entire assemblies, filling the bag with helium, and waiting for several minutes to observe small leaks.

Because vacuum pumps are rated on a volumetric-displacement basis, even the smallest leak of 10^{-9} atmosphere-liter/sec can stall a 1000-liter/sec pump capable of producing 10^{-11} mm-Hg pressure and cause the equilibrium pressure of the system to be in the order of 10^{-8} mm-Hg.

It is very difficult to predict ultimate pressure of the system in the presence of leaks because the ultimate pressure depends on the size and location of the leaks and the conductance between the pump and the leaks. All subassemblies of a system should be leak-checked after cleaning and prior to the assembly into a finished system.

Pumps and Pump Fluid

The system must employ a diffusion pump capable of producing ultra-high vacuum. Table II lists the results of tests on various commercial diffusion pumps.

Either oil or mercury is satisfactory for use as diffusion-pump fluids; however, mercury pumps are used in the C-Stellarator system. The following factors must be considered prior to making a decision to use either oil or mercury.

First, although oil diffusion pumps can produce ultra-high vacuum, it seems that a portion of the partial pressure of carbon monoxide in the vacuum system is generated by the pump. Pump fractions are difficult to trap because of the numerous varieties produced. In addition, pump oil has a limited life.

Second, mercury diffusion pumps can produce ultra-high vacuum. Mercury is easily trapped, does not break down and wear out, and will keep the system under vacuum indefinitely. However, a mercury-pumped system requires a Freon refrigeration system to prevent mercury from overloading the liquid-nitrogen trap and from contaminating the fore-pump oil.

Exhaust from a mercury pumping system should be vented out of the building to avoid any health hazards from mercury-vapor poisoning. Oil vapor from the fore-pump system can be cracked in the mercury pump, yielding the same hard-to-trap fractions present in oil diffusion pumps. Finally, carbon monoxide has also been found in ultra-high-vacuum systems using mercury as a pump fluid.

Ion and sputter pumps can produce ultra-high vacuum. These pumps are basically brute-force getters that pump out gases by means of chemical reaction—by *absorption*, in which gas enters into the interior of the gettering metal, or by *adsorption*, in which the gas condenses in layers many molecules thick on the clean metallic surfaces resulting from the getter metal sputtering or evaporating in the vacuum. Ion pumps have a tendency to break down and block under the high gas loads encountered in tube processing, and they require elaborate control devices. Some commercial models using titanium as a getter material give off as much gas as they pump because the titanium used in them is not vacuum-processed and contains argon used in smelting the metal. All getter pumps remove inert gases at very low speeds—some of them in fractions of a liter per second. Such pumps should have a definite future in tube processing or as attachments to tubes when they are further developed.

Liquid-Nitrogen Traps

The system must have liquid-nitrogen traps of satisfactory construction capable of maintaining ultra-high vacuum (Fig. 8).

The prerequisites for suitable liquid-nitrogen traps are: 1) all of the walls of the trap must remain uniformly and constantly cold at liquid-nitrogen temperature; and 2) there must be no path around the cold surface through which molecules can migrate on the surface from the low-vacuum side of the trap to the high-vacuum side of the trap without passing over a cold surface.

A simple U-tube satisfies these requirements; ball traps and re-entrant traps will not maintain an ultra-high vacuum unless they are used in series.

Assembly Bakeout

The *entire vacuum system*, including the traps and gauges, must be baked out above 375°C for several hours.

It has been the practice in developing systems for the C-Stellarator to bake the assembly at 450°C for a period of at least 18 hours for the first bake, and for at least 12 hours for subsequent bakings after the vacuum system is opened to

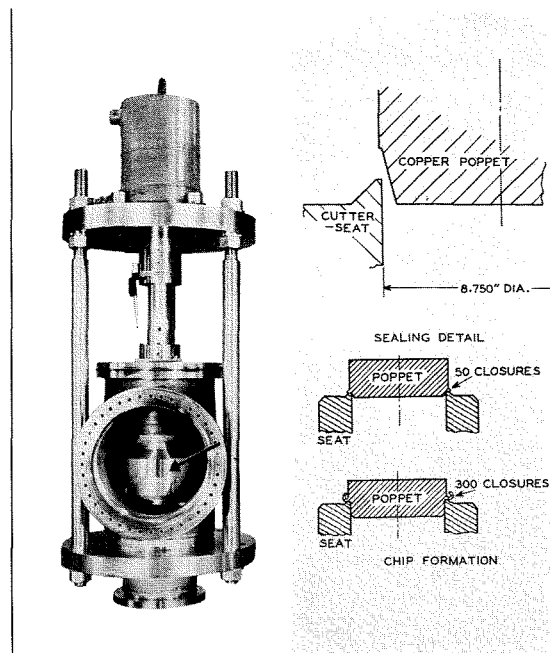

Fig. 5—The special bakeable valve designed for the C-Stellarator ultra-high-vacuum system. Arrow indicates poppet (open). Diagram shows novel method of sealing for repeated closures.

air; however, there are exceptions to this baking time. For example, some mercury-pumped systems have been operated at ultra-high vacuums of 10^{-10} mm-Hg. after exposure to air without subsequent bakeouts. For this operation, the stainless-steel vacuum system was kept heated at 150°C during the time it was exposed to atmosphere and, thus, moisture was prevented from condensing on the vacuum-system surface. No unbaked parts were added to the system when it was exposed to atmosphere.

A block diagram of an ultra-high-vacuum system is shown in Fig. 9. A good bakeout procedure is to heat the entire system for a period of 10 hours. The No. 1 trap should then be cooled and filled with liquid nitrogen while the remainder of the system continues to bake for an additional eight hours. The system is then cooled to room temperature, the ionization gauge is bombarded, and the No. 2 liquid-nitrogen trap is filled.

Pressure during the 450°C bakeout should be approximately 5×10^{-5} mm-Hg. In a stainless-steel vacuum system

Fig. 6—Typical 1/4-inch heating and insulating arrangement for bakeout, which provides 28,000 volts breakdown of insulation and 3.2 watts/in² of heater power at 450°C .

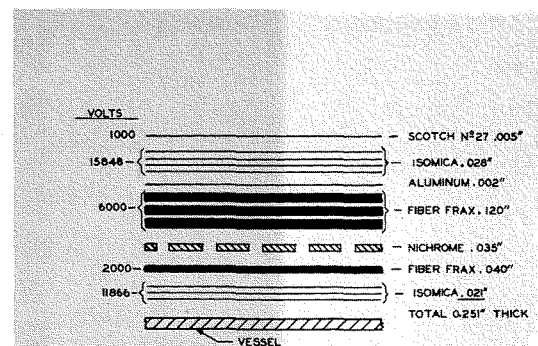

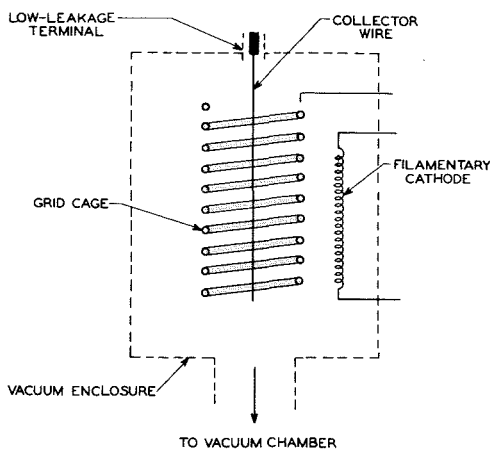

Fig. 7—Ultra-high-vacuum gauge.

having one trap cold and the rest of the system at room temperature; for example, normal pressure readings using an MCF-300 pump were 1×10^{-9} mm-Hg. Trap No. 2 is the so-called *clean trap* and seems to gather the carbon monoxide, oxygen, and nitrogen in the system. Because these gases liquefy near liquid-nitrogen temperature, trap No. 2 soon becomes saturated with monolayers of gas and will eventually adsorb no more. When, after several hours, trap No. 2 becomes saturated, it is necessary to warm the trap and allow the collected gas to be pumped away. After the trap is warmed to -185°C (above the release temperature for carbon monoxide, oxygen, and nitrogen), it can be filled again, and the system will again drop to 10^{-10} mm-Hg. This procedure is called *trap cycling* and can be continued indefinitely to increase the vacuum to the 10^{-11} range.

The ionization gauge should be located on the high-vacuum side of the ultra-high-vacuum trap. If the ion gauges are located between the pump and the trap, any oil vapor originating in the pump can be deposited on the hot filament of the gauge. Such deposits produce oil fractions which are not condensable on liquid-nitrogen traps and which, therefore, contaminate the system and limit the ultimate pressure.

Design Practices

No decisions can be left to the welding and brazing technicians who assemble the system. All welds and brazes should be precisely specified, along with brazing temperatures, weld current, speed, electrode size, and gas flow (if Heliarc is used). Welded joints should be designed for self-jigging fusion welding wherever possible, and any internal cracks and crevices should be avoided. Flux-coated filler and rod welds are not recommended.

All internal surfaces must be as smooth and crack-free as practical to reduce the surface area and to keep trapped dirt and possible contamination at an absolute minimum. (No quantitative data are available determining to what extent smoothness should be pur-

sued; however, a designer should use discretion.)

Type-304-series stainless-steel is an excellent material, easily welded and cleaned, which resists oxidation at elevated temperatures. Gold-seal flanges are recommended with the flange and bolt material of 300-series stainless-steel. The gold wire should be well annealed prior to final accurate sizing for assembly.

The following cleaning procedure is recommended: 1) degreasing of all parts, 2) washing in hot distilled water, 3) oxidation at 250°C , 4) firing in dry hydrogen to reduce oxides, and 5) installation in the system.

If firing is impossible at assembly, the following cleaning procedure is satisfactory: 1) degreasing, 2) washing in hot distilled water, 3) drying with acetone, and 4) installation and use in the system.

ACKNOWLEDGEMENTS

The authors wish to express their appreciation to Dr. D. J. Grove and Dr. G. Lewin of the Forrestal Laboratories, Dr. P. T. Smith (RCA) and D. Scag (Allis Chalmers) of C-Stellarator Associates, and Dr. R. Hoeng and W. N. Parker of RCA, without whose experience and advice this work could not have progressed.

BIBLIOGRAPHY

1. S. Dushman, *Vacuum Technique*, John Wiley and Sons, August 1949.
2. I. E. Martin, J. A. Powell, and J. A. Zollman, "Ceramic, Sapphire, and Glass Seals for the Model C Stellarator;" American Vacuum Society Symposium, Oct., 1959; RCA Electron Tube Division, Lancaster, Pa.
3. W. G. Henderson, J. T. Mark, and C. S. Geiger, "Evaluation of Large Diffusion Pumps and Traps for the Ultra High Vacuum System of the Model C Stellarator;" American Vacuum Society Symposium, Oct. 1959; RCA Electron Tube Division, Lancaster, Pa.
4. K. Dreyer and J. T. Mark, "The Ultra-High-Vacuum System for the C-Stellarator," *RCA Review*, Vol. XXI, No. 4, Dec. 1960.
5. R. T. Bayard and D. Alpert, *Review of Scientific Instruments*, pp. 21, 571; 1950.
6. R. E. Honig, "Vapor Pressure Data for the More Common Elements," *RCA Review*, Vol. XVIII, No. 2; June 1957.

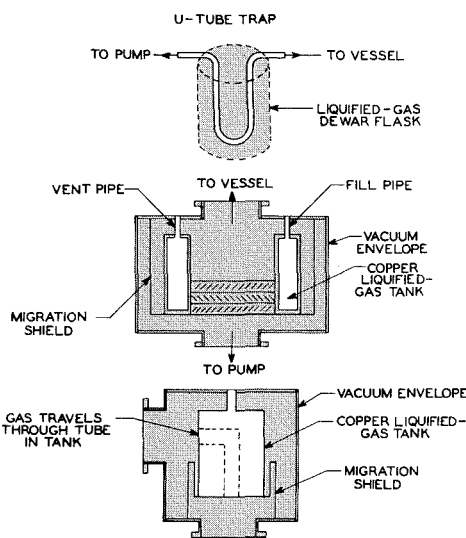

Fig. 8—Liquefied-gas traps.

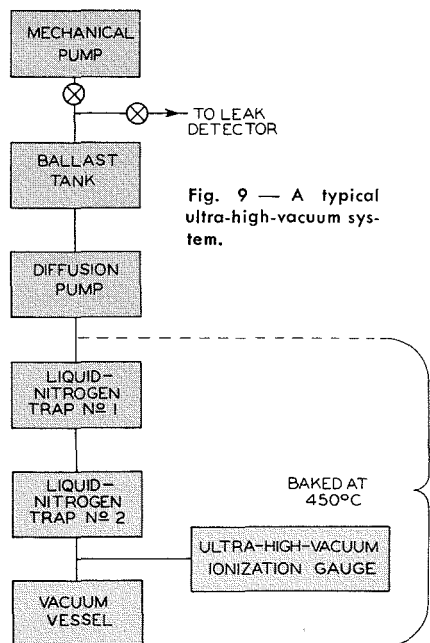
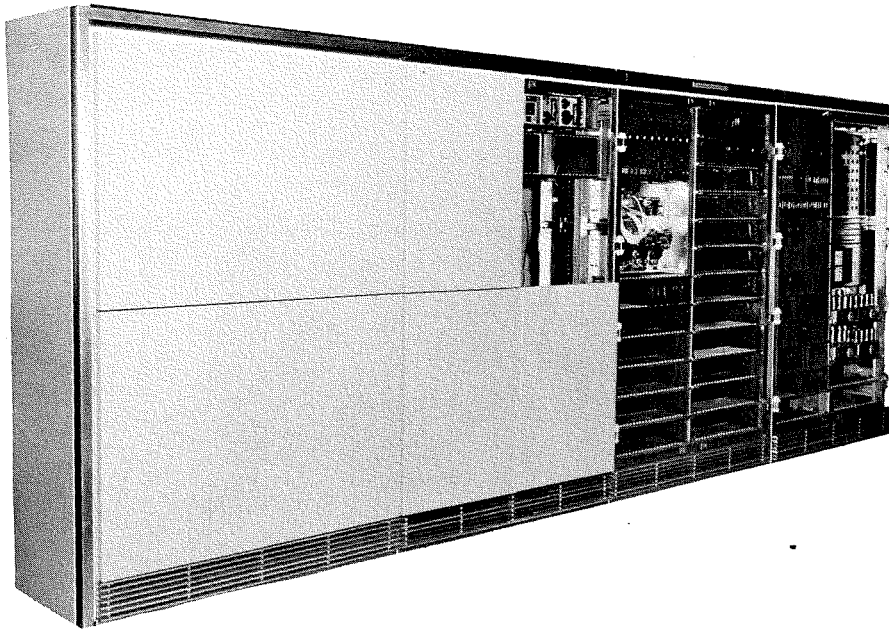

Fig. 9 — A typical ultra-high-vacuum system.

TABLE II — PERFORMANCE OF VARIOUS COMMERCIAL DIFFUSION PUMPS

Pump	Heater Pwr., watts	Water Δ , $^\circ\text{C}$	Stages	Back-streaming, mm^3/min	Forepress. tolerance, μ		Ultimate (Veeco RG-75), mm-Hg
					Air	He	
CEC, MCF 1400	2900	21	3	3.64	250	250	4.3×10^{-10}
NRC, HP10	2300	6.5	3	0.364	250	200	2.0×10^{-10}
Kinney, 100F	2350	16	6	0.03	135**	40**	4.2×10^{-10}
Leybold, D020001	2350	10	3	0.03	500	320	4.0×10^{-10}
HVE, HV-10F	1900	7.5	3	0.719 (min)	150	80	1.4×10^{-9}
CEC, PMC1440*	1725	21.4	4	***	500	400	4.0×10^{-10}
CEC, MHG300A(Hg)	1000	11	3	—	200	300	1.5×10^{-10}
Leybold 500 (Hg)	800	5.5	2	—	—	—	6.0×10^{-9}

*Prototype; **Continual; ***No indication after 53 hours.



by P. E. SLAVIN

Industrial Computer Systems Dept.,
Electronic Data Processing Division
IEP, Natick, Mass.

EXTENSIVE ELECTRONICS are required for the control of the massive array of equipment necessary for the thermonuclear plasma experiments of the C-Stellarator. One part of the controls (Fig. 1) is the *Equipment Action Sequence Timer (EAST)*, which directs much of the C-Stellarator apparatus.

TIMER REQUIREMENTS

The timer may be thought of as 80 persons, each controlling a stop-watch, all 80 watches being synchronized with each other and with an absolute standard to a precision of about $0.1 \mu\text{sec}$. Each movement of the large hand of each stop-watch indicates the elapse of $10 \mu\text{sec}$, while the small hand indicates 10-second steps. Of the 80 persons, some 25 have the task of switching on or off major equipment, such as the main apparatus which generates the field current and ohmic heating current. These currents are of the order of 45,000 amperes, so that they have enough inertia to make a time selection to 10 msec adequate.

Since these major switching actions may be arranged in various experimental patterns, many inhibiting and warning reactions are included in the timer system. For example, the five confining field actions must be in sequence and within a preset start-stop range, or else all field and major action is stopped. In this range, the sequence of the field start times is examined, and should a discrepancy exist, shutdown of the system will occur.

On the remaining 55 channels, a time selection to 10 msec is not adequate. These channels provide trigger pulses to instrumentation such as oscilloscopes and need the vernier steps of $10 \mu\text{sec}$. This necessity arises from the very brief period in which the critical reactions are anticipated, although the period of preparation and shutdown may last as long as 200 seconds. This very brief time is defined by T_0 , the instant when this action starts. The timed events prior to the critical few milliseconds of plasma reactions are measured in *time before* T_0 .

TIMER SYSTEM

The actual timing of the C-Stellarator is implemented with transistor gates, using time pulses as inputs. These pulses are derived from a 1-Mc oscillator whose pulse outputs are divided by transistor ring counters into pulses

EQUIPMENT ACTION SEQUENCE TIMER ... Precision for the C-Stellarator

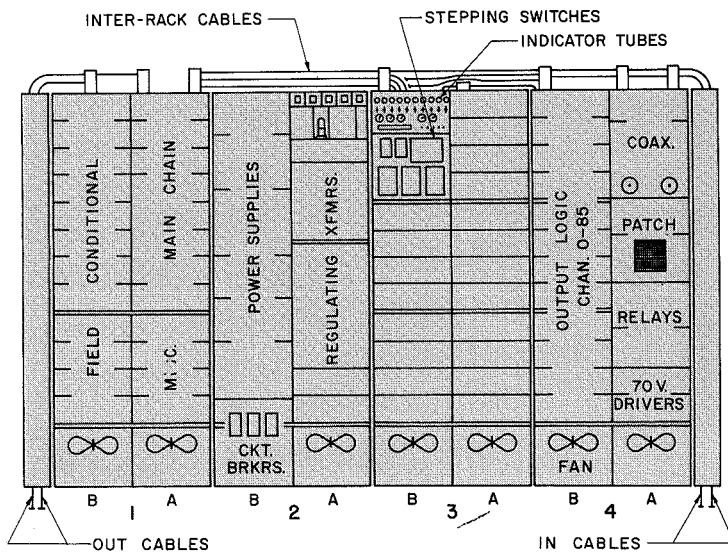

Fig. 1—Photo of timer equipment. Diagram illustrates layout of racks.

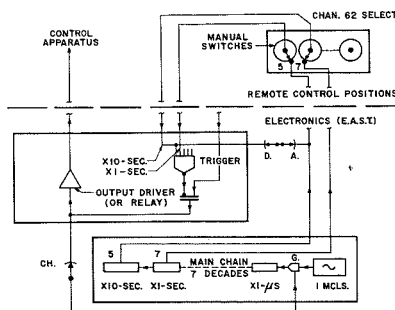

Fig. 2—Seven decades in main timer chain.

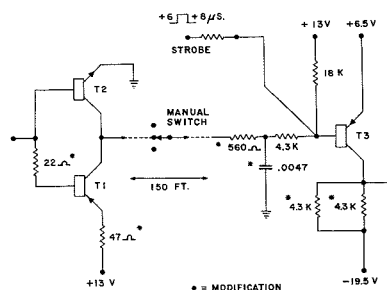

Fig. 3—Modifications to usual digital circuits.

of varying duration, with the longest lasting 10 seconds and occurring every 100 seconds. The crystal oscillator has a stability of 5 parts in 10 million. The high-impedance sine wave from the oscillator is converted by a Schmitt-type circuit into a low-impedance pulse train. Fig. 2 shows the seven decades (decimal dividers) as used in the main chain of the timer.

There are 16 additional decades arranged in various chains. While all but one have pulse trains from the main chain as input, the train selected can be varied by an operator, as can the instant at which these auxiliary decades begin to count time.

Each of the seven main decades has 10 shift-register stages whose emitter-follower outputs are connected through long lines (70 feet) to remote control positions. The remote control position consists of manually operated ten-position switches, of which there is one for each decade in each time selection (channel). The shift registers have been modified so that each time a 1 arrives in the zero bit position, all stages are reset and the 1 is reinserted into zero. This prevents having two 1's in the shift register at the same time.

Shift registers were used in preference to binary counters, since such counters need decoding gates, have transient false digits at each count, and involve propagation time problems.

A particular manual switch might be set to 7. If that switch selects seconds, then at 7 seconds there will be a pulse returning from this switch and going into the *and* gate for this channel. When all chosen pulses are *on*, i.e. positive, the *and* gate will have an output. This output may be made into a low-level pulse, a relay contact closure, or a high-power pulse. The *and* gate output is amplified and sent via long lines, including coaxial cables, to control equipment or to trigger points of data-recording instruments such as oscilloscopes.

EQUIPMENT

The transistorized time-pulse system is built into four racks of the RCA 501 type (Fig. 1).

The main chain and the other decades originating time pulses are in Rack No. 1, and the output *and* gates and drivers are in Rack No. 4. The logic circuits are contained on printed-circuit boards, which are located in Rack 4B. Two thirds of these boards fall in one of three types: *gate*, *inverter*, and *shift register*. Rack 4A has the patch board for the relay outputs, the pulse output patching, and four pluggable trays of

relays. Cable connections to remote equipment are made at the end of the rack.

Rack 2 contains the power supplies (typical, 60 amperes at -19.5 volts). Over-all regulation of 5 percent was adequate for the logic used.

Rack 3 holds the check-out indicators and switching devices. This switching was done by eight stepping switches driven by power transistors. There is no twisted-pair or shielding or coaxial wiring except in the case of the outputs to the remote equipment. Because of low impedance circuits and care taken in cabling the strobe pulses, there has been to date no serious cross-talk problem.

LONG-LINE MODIFICATIONS

The long lines as used in the time-pulse system demand that certain modifications be made to the usual application of digital circuits (Fig. 3). It was necessary, for example, to include a filter at the long-line receiving end. The filter used in the timer has an r-c time constant of approximately 2.5 μ sec. The capacitance is three times greater than the capacitance between 150-foot conductors in multi-conductor cable. The resistance value is a compromise between long-delay and large-in-rush current. The precision of the Timer is retained at 0.1 μ sec. by strobing all channel gates in the interval between 6 to 8 μ sec. (occurring every 10 μ sec). This interval was chosen because the effective input voltage at the filter capacitor has settled down at that time. The driver circuit, consisting of an emitter-follower pair, has had its pnp transistor modified to limit its current to 120ma so as to protect the transistor from transient line grounds.

Initial concern about inductive pick-up in the long lines from the confining magnetic field was alleviated through shields of eight mils of aluminum. Typically, the magnetic field could approach 60 kilogauss within 2 seconds over a magnetic path of 40 feet. With the long lines about 80 feet away from the field at the torus, the high-frequency (e.g., 5-kc) pick-up can be calculated as a few millivolts. The low-frequency pick-up will be even less, chiefly due to the wavelength of the field being greater than the torus to lines distance.

The inductive coupling between parallel lines can be calculated from: $CURL H = 4 \pi I$. This turns out to be less than five millivolts in the worst case.

Separate ground returns were provided for each Shockley diode output driver, because of the extreme rate of rise of current at "firing."

CHECKOUT SYSTEM

The checkout system is largely automatic. After the operator manually selects a certain time and channel, the switching connects this time to the particular channel output gate (Fig. 2). At the instant of an output from this gate, this output is routed by switch CH to the point where it turns off the one megacycle pulse train. Time then being stopped, these same switches search through the timing decades, stop, and indicate the "time" on numerical read-out tubes.

The eight stepping switches were adapted to a system using common control and markers; i.e., the power transistor drive was shared by all the switches, and all switches stopped when they found a mark on their banks, (as opposed to step-by-step selection).

SUMMARY

The Equipment Action Sequence Timer was designed and built over a six-month period using computer-type printed-circuit boards similar to those used in the RCA 501. It is believed to be the largest electronic timing equipment in use.

PETER E. SLAVIN received the BSEE from the University of Manitoba in 1950. He then completed a two year post-graduate apprenticeship in communications in England. Returning to Canada, he was employed in research groups of Ontario Hydro and General Dynamics. In 1957, he joined the Univac Division of the Remington-Rand Corporation, where he did the electrical design of the Randex, a random-access drum file. Since his employment with RCA in 1959, Mr. Slavin has done design work on such equipment as the C-Stellarator Master Timer and the RCA 110 Industrial Computer. He is presently completing design of the RCA 150 at Natick, Massachusetts. Mr. Slavin is a corporate member of the IEE of England.

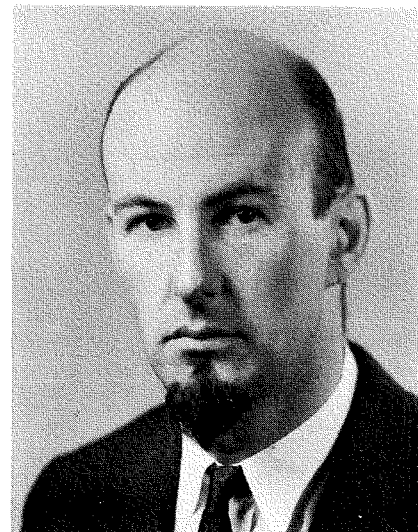

THE MASER . . . Microwave Amplification by Stimulated Emission of Radiation

by

J. M. BRUMBAUGH, D. KARLSONS, and L. C. MORRIS

*Applied Research, Defense Engineering
DEP, Camden, N.J.*

and

DR. H. J. GERRITSEN

*RCA Laboratories
Princeton, N.J.*

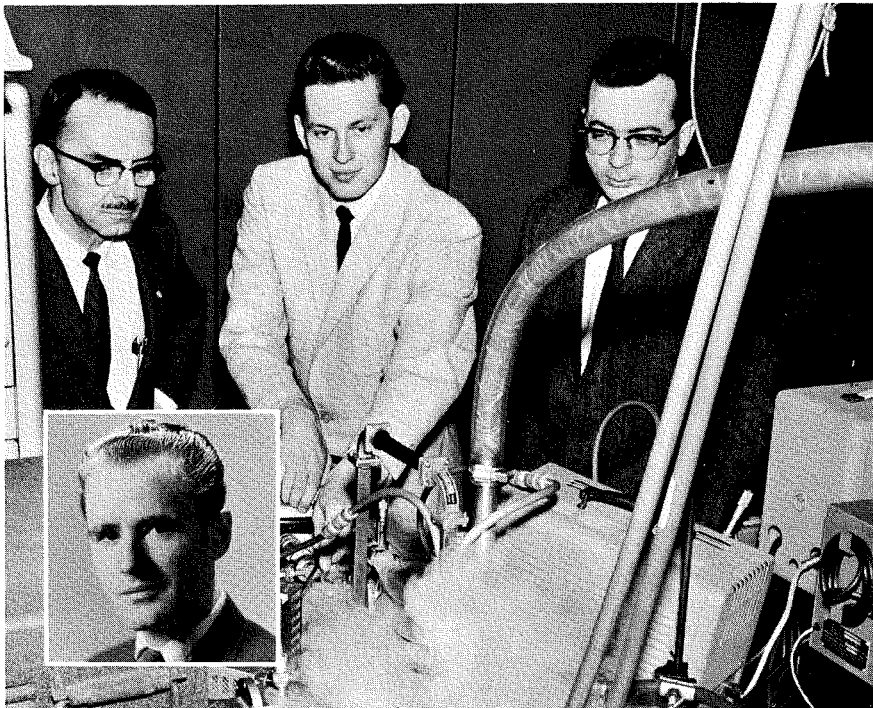

The authors: l. to r., J. M. Brumbaugh, D. Karlsons, and L. C. Morris; inset, Dr. H. V. Gerritsen. Pictured is the DEP Applied Research traveling-wave-maser laboratory setup, with Mr. Karlsons adjusting the liquid-helium supply.

J. M. BRUMBAUGH received his BSEE in 1931 and MSEE in 1932 from the University of Pennsylvania. Mr. Brumbaugh has had 24 years of experience in development, research, and design in communications and electronics. He did design and development work on many military projects during World War II, including the Shoran navigation and bombing equipment and early-warning radar systems. He was responsible for the development of RCA's first operating maser in 1958. He has recently acted as project engineer in the development of special broad-band, traveling-wave masers. He has been concerned with other solid-state developments in the micro- and millimeter-wave fields. Mr. Brumbaugh has been issued eight U.S. patents, and has published numerous papers. He is a senior member of IRE and has been active in committee work.

D. KARLSONS received his BSEE in 1958 from Drexel Institute of Technology, and MSEE in 1960 from the University of Pennsylvania. Since joining RCA he has worked on the design of a 2.4-kmc solid-state cavity maser, and the design and evaluation of meander-line and comb traveling wave masers. He has been instrumental in the development of the first rutile traveling-wave maser. He is presently working on the adaptation of a traveling-wave maser to a low-noise satellite tracking system. Mr. Karlsons is a member of Tau Beta Pi and Phi Kappa Phi.

L. C. MORRIS was graduated from LaSalle College with a BA in Physics and Mathematics in 1956. He is studying toward an MS in Physics at the University of Pennsylvania. At present, Mr. Morris is the project engineer of an RCA funded millimeter wave program. He has performed studies in the area of generation, propagation and detection of millimeter waves. He has participated in the development of RCA's first solid-state cavity maser and is presently participating in the development of traveling wave masers and other maser structures of a more advanced nature. Mr. Morris is a member of the IRE and the professional groups in Microwaves and Electron Devices.

DR. HENDRIK V. GERRITSEN received his Candidates Certificate in Physics and Chemistry in 1948 from the University of Leiden, and his MS in Physics in 1952 and PhD in Physics in 1955, also from the University of Leiden. His doctoral thesis was on anti-ferromagnetic resonance. He joined the staff of Laboratories RCA in Zurich, Switzerland in 1955, where he worked on the physics of the Electrofax reproduction process. Dr. Gerritsen transferred to RCA Laboratories, Princeton, New Jersey, in October, 1957, where he has done original work on masers.

MASERS ARE quantum-electronic devices which amplify or oscillate in the microwave frequency range. The action is confined completely to direct interchanges of energy between electromagnetic fields and bound electrons in a maser material.

In contrast to all other microwave amplifiers, the basic action in the maser material requires no emission, acceleration, or conduction of free electrons, and no variation of parametric circuit elements. This unique feature of masers provides two characteristics which have evoked wide-spread interest: 1) extremely low internal noise in an amplifier of multimegacycle bandwidth and 2) ultra stability as a frequency source for atomic clocks. The first characteristic is necessary for satellite and space-probe communications, where amplification of very weak signals in a low-noise background is necessary, and for applications like radiometry, radio astronomy, and passive reconnaissance, where small differentials in a low-level noise-signal must be observed. The second characteristic is useful for navigation, guidance, data timing and processing, and secure communication.

BACKGROUND

Masers are the outgrowth of basic research by atomic physicists and optical and microwave spectroscopists. In 1924, Uhlenbeck and Goudsmit postulated electron spin to explain the fine-structure in the spectrum of the alkali metals. Zavoiski began experiments with microwave spin resonance in 1945.

In 1956, Bloembergen¹ made a detailed proposal for maser action from solid-state spin-resonance effects, although similar suggestions were made several years earlier by Basov and Prokharov, and by J. Weber.

Although historically the gaseous ammonia maser was developed first, this article will deal broadly with solid-state masers rather than gaseous masers, because the former possess bandwidths which are several orders of magnitude larger than those of the latter, and there are many applications of amplification where large bandwidths are required. However, gaseous masers are superior to solid-state masers as ultra-stable oscillators. Ammonia-beam maser oscillators with a stability of 1 part in 10^{11} have been constructed, and it is expected that a new atomic-hydrogen maser will surpass this performance by several orders of magnitude.

BASIC PRINCIPLES

The mechanism of energy interchange between microwave fields and bound electrons in a crystalline maser material (microwave resonance) is a change in electron-spin orientation in a composite

field, consisting of internal crystalline fields plus an externally-applied magnetostatic field. There are definite allowed orientations which correspond to specific internal energy levels of the active ions in the crystal. These levels, in turn, constitute the optical fine-structure levels which appear almost indistinguishably crowded together as the lowest-energy or ground-state "level" in the optical energy-level diagram of these ions. An example would be the spectrum of trivalent chromium ions in a ruby crystal.

Differences between these fine-structure energy levels correspond to microwave resonant frequencies by the well-known relation, $E_i - E_j = h f_{ij}$, where h is Plank's constant. Furthermore, the resonant frequencies may be varied by changing the external magnetostatic field. This phenomenon is called the *Zeeman splitting* of the optical fine-structure.

At room temperature, these fine-structure energy levels are almost equally populated with as many ions in any one level as in the others. As the temperature of the crystal is lowered to a few degrees Kelvin, the distribution approaches that indicated in Fig. 1. Such equilibrium distribution is a prerequisite for amplification with a maser utilizing the fine-structure energy levels; the reason for this will become apparent later in this article. Thus, cooling of maser crystals to at least liquid-nitrogen temperatures (77.3°K), and often to liquid-helium temperatures (4.2°K) is a requirement for amplifier operation, and is not just a means for achieving low internal noise. Fortunately, cooling does greatly decrease the incidental thermal noise which comes from losses in the associated microwave structures, thus adding very little noise to the amplification process, which itself introduces almost negligible noise.

To realize maser amplification or oscillation, a situation in a solid-state crystal must be achieved where more molecules are in a higher energy level than are present in a lower one. Such a situation is in contrast to the low-temperature thermal equilibrium state of Fig. 1, where the lower level is always more heavily populated. For this reason, this desired inversion of populations is sometimes referred to as *negative temperature*. If a microwave field is present at a frequency corresponding to the resonance between the two population-inverted levels, molecules in the upper energy level will be stimulated by the field to drop down to the lower level, thus emitting energy which adds coherently to the radiation that stimulated the process. Amplification may thus be obtained.

To be somewhat more specific, consider a typical energy level diagram such as that for divalent nickel ions present in a dilution of about 1 percent in a crystal of $MgSiF_6 \cdot 6H_2O$. For a certain value and orientation of an externally applied magnetic field, the energy levels are as shown in Fig. 1. The three levels come about because unpaired electrons in the crystal can orient themselves in three ways: parallel, perpendicular, or antiparallel to the field. The length of the arrows indicates the number of nickel ions in the particular level and was calculated according to the Boltzmann statistics $n_j = n_i \exp(-h f_{ij}/kT)$, where n_q is the number of molecules in energy level E_q , k is Boltzmann's constant, and T is the temperature of the material. (In this case $n_1 + n_2 + n_3$ would equal the total number of ions in the crystal.)

When a microwave field of frequency f_{12} is applied to the crystal, there are three basic interactions of matter with radiation that should be considered: stimulated emission, absorption, and spontaneous emission.

Statistically, the first two are equally probable but of opposite sign, and proportional to the energy density of the microwave field. Spontaneous emission is always present, and this means that a molecule in level 2 has a finite probability to fall back spontaneously to level 1, even if thermal effects due to lattice vibration were not present.

The probability rate that a single nickel ion in level 2 would drop down to level 1 due to spontaneous emission is about 10^5 years. If the crystal in the example were placed in a resonant cavity, this time would be reduced by a factor of about 10^3 and would be further reduced when other interactions are taken into account.

Spontaneous emission is thus too weak to give any considerable loss of molecules from higher to lower levels. Theoretically, spontaneous emission is the limiting noise source in a maser.

The major loss of molecules from the higher energy level is caused by the lattice vibrations, which try to establish an equilibrium situation such as sketched in Fig. 1. The time constant in this process is called the spin-lattice relaxation time (typically of the order of 5 to 100 msec for useful maser materials at 1.5°K).

Thus, a microwave field strong enough to produce stimulated emission and absorption, at a rate large compared to this rate of 5 to 100 msec, will tend to equalize the populations of the two levels. Depending on the material used, temperature, and microwave structure, the power required to do this is, typically, from 100 to 0.1 mw.

The difference in population between the two levels is given by:

$$N_1 - N_2 = \frac{1}{1 + \frac{2\pi T_1}{\Delta f} \left(\frac{\mu H_{RF}}{h} \right)^2} \quad (1)$$

Where: T_1 = spin lattice relaxation time, Δf = line width of the material (e.g., 50 Mc), $\mu \approx 10^{-20}$ emu, $h = 6.6 \times 10^{-27}$ erg-seconds. Thus, for a typical case, H_{RF} , the microwave magnetic field intensity, has to be larger than about 0.02 gauss before induced emission and absorption becomes more important than relaxation.

If such a strong microwave field is applied at frequency f_{12} , the effect would be the following: Just after turning on the microwave power, the effect of the stimulated absorption would be to raise the molecules from level 1 into level 2, and because of stimulated emission, all the molecules initially in level 2 would drop to level 1. If the microwave power were then stopped, a state of negative temperature would exist for a time as long as the spin-lattice relaxation time. This process obviously does not allow a sustained negative temperature.

By the utilization of three energy levels, however, a sustained negative temperature may be achieved. This is accomplished by use of an auxiliary microwave field at frequency f_{13} (called the *pump frequency*) to equalize the populations of levels 1 and 3. If the energy levels are chosen so that the molecules in level 2 relax slowly to level 1 (compared to the rate of molecules being pumped from 1 to 3, and the rate of molecules dropping from 3 to 2), molecules will accumulate in level 2 and this level will be continuously overpopulated compared to both levels 1 and 3. Radiation corresponding to drops from level 2 to level 1 is now easily stimulated by a very weak "signal" microwave field of frequency f_{12} . This continuous negative temperature situation produced by the pump thus allows amplification at frequency f_{12} .

The signal power can not be too large, however, or it will start to equalize the inverted population used for amplification, thus causing the amplifier to saturate. In general, the signal power should not be much larger than a few microwatts. It also follows that the signal frequency is less than the pump frequency. This is a serious difficulty if it is desired to operate masers in the millimeter-wave range, but can be overcome if 4 or more levels are used. Figs. 2a, b, c show some of these schemes. Fig. 2a has been successfully applied using chromium-doped potassium cobalticyanide to which iron was added to shorten relaxation time 2-3.

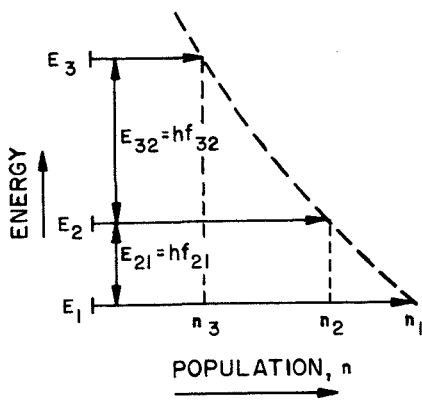

Fig. 1—Typical energy-level diagram; divalent nickel ions present in a dilution of about 1 percent in a crystal of $MgSiF_6 \cdot 6H_2O$.

The result was a pump at 5 kMc and a signal at 9 kMc. The scheme in Fig. 2c has been used in chromium-doped sapphire (ruby), with pump at 9 kMc and signal at 10 kMc.

MASER MATERIALS

Among the first solid-state maser materials to be used were lanthanum ethyl sulfate with various rare earth dopings and chromium-doped potassium cobalticyanide. These materials were found to possess energy levels whose separation corresponds to relatively low microwave frequencies. In addition, these materials suffer the instabilities of water-bound crystals, and their physical properties are such that repeated temperature cycling in and out of the helium bath causes them to chip and crack. Other crystals, such as ruby and emerald, were later found to be applicable to maser operation; these materials possess higher energy level separations, are immune to repeated temperature cycling, and are also quite insoluble in water.

Three-level amplification with ruby can be achieved at frequencies extending above X-band, and that with emerald at still higher frequencies. With still newer materials, namely rutile doped with iron and/or chromium, it should be possible

to increase the highest signal frequency amplified so far (40 kMc with 3-level operation) by a factor of about three by using the 4-level schemes described above.

Ultra-low noise and appreciable bandwidth can only be obtained at liquid helium temperatures with present-day materials, but ruby masers have been operated at liquid-nitrogen temperatures with a voltage gain-bandwidth product of 14 Mc and 100°K noise temperature. Both figures get better at helium temperatures by $1\frac{1}{2}$ orders of magnitude. Since the development of chromium-doped rutile at the RCA Laboratories and iron-doped rutile at Columbia University, it seems that this material not only will allow amplification at much higher frequencies, but also will simultaneously improve the low frequency masers. An additional advantage of rutile is its large dielectric constant of 200, permitting the use of small structures.

NOISE PERFORMANCE

Quite generally, the noise power in a bandwidth Δf centered at frequency f and emitted by a blackbody at temperature T is given by:

$$P_N = \frac{hf}{\exp(hf/kT) - 1} \Delta f \quad (2)$$

This reduces to the well-known Nyquist formula $P_N = \Delta f kT$, for $hf \ll kT$. Thus, the noise power emitted by a blackbody per unit bandwidth could be specified in terms of T , which could be called the noise temperature of the blackbody. Under the same approximation, the noise temperature of a maser, T_N , is in general of the order of $T_N = T_{\text{bath}} \times (\text{signal frequency/idler frequency})$, where the idler frequency is the difference between the pump and signal frequencies. The T_N of a maser operating at liquid-helium temperatures can easily be 2°K, and this value can still be appreciably reduced with a rutile maser, where large idler

frequencies are possible. The basic limiting noise temperature of any maser is hf/k , which works out to about 0.5°K at 10 kMc. This limiting value, when compared to a maser experimental value of 2°K at 10 kMc, indicates how close the maser noise can approach the absolute minimum. The maser is certainly good enough for communication from the earth, where the noise temperature of the sky is never less than 2°K.

CAVITY MASERS

Since maser operation depends on interaction of microwave fields with the active maser material, there has to be an effective way to apply the microwave fields to the crystal. One way to concentrate the required microwave fields in the vicinity of the maser crystal is to place the crystal in a microwave cavity which is resonant at both the signal and pump frequencies.

Capacitance-loaded coaxial cavities have been chosen frequency for use in three-level cavity masers. They are easy to tune mechanically and relatively simple to construct.

The pertinent dimensions of a double-tuned coaxial cavity are shown in Fig. 3. To allow adjustment to pump and signal resonances, the gap d is made variable by providing a movable plunger counter-opposed to the inner post of the cavity. The plunger is designed to penetrate a comparatively small distance within the cavity, so that in determining the proper dimensions, the cavity can be considered a foreshortened coaxial line.

The gain-bandwidth product for the cavity maser is essentially a constant quantity and is given to a close degree of approximation by:

$$G^{1/2}B = \frac{2f_s}{Q_r + |Q_m|} \quad (3)$$

Where: G is the power gain, B is the (3-db) bandwidth, f_s is the signal frequency, Q_r is the Q of the resonance line defined as $f_s/\Delta f$, where Δf is the paramagnetic linewidth and typically of the

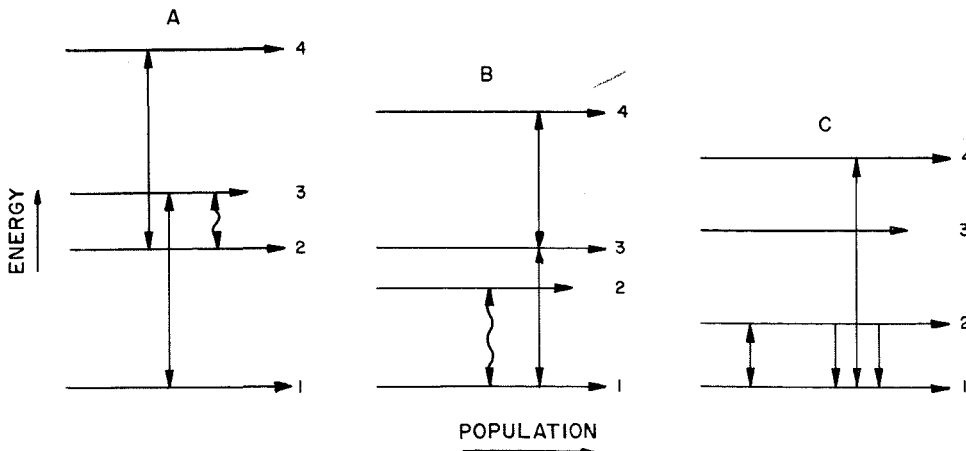

Fig. 2—a) PUSH-PULL SCHEME: $f_{13} = f_{24}$ and both transitions are pumped. In addition, the spin-lattice relaxation time between levels 2 and 3 is much shorter than the relaxation times connecting the other levels. Amplification is possible at f_{41} and at $f_{21} = f_{43}$. b) PUSH-PUSH SCHEME: Now $f_{13} = f_{34}$ are pumped and f_{12} has a very short relaxation time. The amplification frequency is f_{42} . c) HARMONIC PUMPING: In this example, $f_{12} = f_{24}/3$. In not-too-dilute crystals, a process is possible which conserves energy whereby 3 molecules go from level 2 to 1, while one moves up from level 2 to 4. In this way, it is possible, by pumping at f_{12} , to saturate also level 4, allowing amplification at f_{34} .

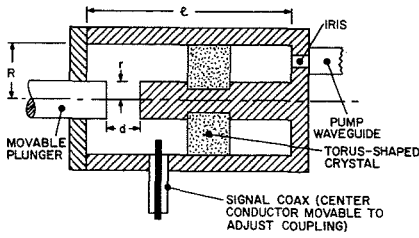

Fig. 3—Pertinent dimensions of a double-tuned coaxial cavity.

order of 20 to 80 Mc. The magnetic Q is defined as

$$Q_m = 2\pi f_s \times \frac{\text{(signal energy stored in cavity)}}{\text{(signal power absorbed by maser material)}} \quad (4)$$

When power is emitted by the maser material rather than being absorbed, Q_m becomes a negative quantity. The magnetic Q is predominantly a property of the maser material, being dependent, in part, on the temperature of the material and the frequency of operation. Magnetic Q 's of the order of -50 to -1000 are typical for present maser materials.

The expression for the gain of a cavity maser is:

$$G^{1/2} = \frac{\frac{1}{Q_{ext}} - \frac{1}{Q_o} + \frac{1}{|Q_m|}}{\frac{1}{Q_{ext}} - \frac{1}{Q_o} - \frac{1}{|Q_m|}} \cong \frac{\frac{1}{Q_{ext}} + \frac{1}{|Q_m|}}{\frac{1}{Q_{ext}} - \frac{1}{|Q_m|}} \quad (5)$$

Where: Q_o is the cavity Q measured for a very undercoupled situation; Q_{ext} is related to the energy lost through the coupling hole. Of course, the observed Q is given by:

$$\frac{1}{Q_{obs}} = \frac{1}{Q_o} + \frac{1}{Q_{ext}} \quad (6)$$

For a typical ruby maser, $Q_o = 5000$; $|Q_m| = 150$; $Q_{ext} = 100$ which justifies the use of the approximate equation 5.

Bandwidth can be traded for gain as per equation 3. This can be accomplished by changing the cavity coupling and thus changing Q_{ext} , which results in a change of gain and bandwidth as seen from

TABLE I—TYPICAL RCA CAVITY-MASER OPERATING CONDITIONS

Material	Signal Frequency, kMc	Pump Frequency, kMc	$G^{1/2}B$, Mc
Potassium Cobalti			
Cyanide-Cr	2.1	9.6	2.5
Rutile-Cr	9.0	34.0	25
Rutile-Cr	24.0	70.0	20

equations 5 and 3. Of course, $Q_{ext} < |Q_m|$, or the device will break into oscillation.

Typical operating conditions of three RCA cavity masers are listed in Table I.

TRAVELING-WAVE MASERS

In the case of the cavity maser, the gain-bandwidth product was limited by the properties of the maser material. For some applications requiring a low-noise microwave amplifier, the bandwidth available at a certain gain is not sufficiently large. The narrowband limitations imposed by a cavity can be overcome by using a broadband structure to couple microwave energy to the maser material. Such broadband devices as the meander line and comb slow-wave structures have been found to be effective coupling media. The bandwidth of a traveling-wave maser is given by⁵:

$$B = \Delta f \sqrt{\frac{3}{G_{ab} - 3}} \quad (7)$$

Where: Δf is the linewidth of the maser material itself, and G_{ab} is the power gain in db. A typical value of Δf for the maser materials discussed in this article is of the order of 50 Mc. With typical slow-wave structure, it is possible, then, to increase the bandwidth of amplification by an order of magnitude over that of a cavity maser. It has been tacitly assumed that the passband of the slow-wave structure is at least as great or greater than Δf , so that the bandwidth of amplification is entirely determined by the linewidth of the maser material.

The decibel gain of the traveling-wave maser is given by:

$$G_{ab} = \frac{27.3 cN}{|Q_m| v_g} \quad (8)$$

Where: c is the velocity of light, N is the length of the slow-wave structure divided by the free-space wavelength, and v_g is the propagation velocity of the microwave energy along the slow-wave structure. This shows that gain can be increased by doing any or all of the following: 1) increasing the length of the slow-wave structure, 2) decreasing v_g and 3) using a material with a smaller Q_m .

The slow-wave structure propagates the microwave fields necessary for interaction with the maser material. By slowing the velocity of propagation of microwave energy along the maser material, the slow-wave structure provides sufficient time for the interaction. The active material can be thought of as a negative resistance which negatively attenuates, i.e., amplifies, the traveling wave as it propagates along the slow-wave structure.

Pump energy is applied to the maser material by placing the slow-wave struc-

ture together with the material in a tuned cavity at the end of the pump waveguide.

Another advantage of a traveling wave maser, being a two-port device, over a with the former to provide means for intrinsic unidirectional amplification, together with reciprocal attenuation. Thus an effective means for isolating input from output can be contained within the traveling wave maser, whereas the one-port cavity maser requires an external circulator for proper operation, which, in general, can give rise to extra noise.

The meander line is shown in Fig. 4. The passband center frequency corresponds to the a dimension, equal to a quarter free-space wavelength. When the active material is present, the a dimension is modified to

$$a = \frac{\lambda}{4 \sqrt{\epsilon}} \quad (9)$$

Where: ϵ is the dielectric constant of the active material. Changes in the ratio b/p have a slight effect on the passband of the meander line. A small value of p is desired, because the smaller the pitch, the smaller the value of v_g , and therefore, by equation 8, the greater the gain. Dimension b must be necessarily small in order to have a small pitch.

An experimental meander line was fabricated by printed-circuit techniques; it was etched from a 1-mil copper foil on a 1-mil mylar base. The pitch of the meander line was tapered at both ends in order to match the impedance with that of the co-axial feed lines. Fig. 5 is a photograph of the meander line mounted in the pump cavity. A meander line, designed to operate with ruby at a center frequency of 5.2 kMc ($a = 0.180$ inch), has a passband ranging from 4.0 to 6.5 kMc.

The comb structure, shown in Fig. 6, is an array of quarter-wavelength resonant rods. Capacitance effects between the rods and between rods and pump cavity, as well as the dielectric loading of the maser material alters the passband center frequency correspondent to the length of the rods; for instance, the rods in an RCA comb structure are 0.4 inch long, corresponding to a resonant frequency of 7.38 kMc. The above effects change this frequency to 6.1 kMc, with slowing extending to 0.2 kMc on both sides of it.

Maser operation with ruby has yielded electronic gain (i.e. intrinsic gain without considering losses) of about 7 db/inch of active meander line with a related bandwidth in the order of 30 Mc. Typical ruby operation with the comb structure gave an electronic gain of approximately 6 db/inch over a bandwidth of about 20 Mc. These results should be considered as preliminary for both structures,

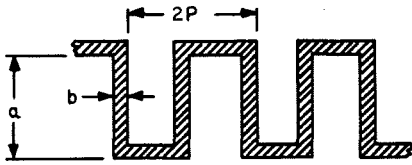

Fig. 4—Meander line.

since several operating factors are known to be non-optimized. Operation with rutile as the active material is expected to yield higher gains because 1) the Q_m of rutile is approximately one-third of the Q_m for ruby, which by equation 8 should increase the gain by a factor of three, and 2) the dielectric constant of rutile is about 20 times that of ruby, which would decrease v_g in the case of the meander line and, therefore, increase the gain. In such structures the paramagnetic resonance line would be artificially broadened so that the increase in gain could be traded for wider bandwidth.

APPLICATIONS

Important considerations to be analyzed before a maser can be effectively applied to a microwave system are such factors as the amplification frequency, the antenna noise temperature and the environment in which this system will operate. For transmission through the atmosphere, certain frequency "windows" are best suited for the application of a maser. These bands of low attenuation, which have correspondingly low values of atmospheric background noise, are found in the region 2 to 12 kMc, 32 kMc, and 85 kMc. In operations where the antenna looks at the ground, noise temperatures as high as 300°K are encountered, determining the limiting sensitivity of operation. However, by staying 10° or more away from the horizon, the noise temperature of the sky is at most 20°K and at least 2°K for the first microwave window. A 6-kMc traveling-wave maser at Bell Labs had a measured noise temperature of 10°K. To obtain maximum performance from the maser, it is clear that problems in antenna design such as elimination of ground lobes, noisy feedlines, and components must all be solved.

Some applications of the solid-state maser which appear obvious are 1) secure communications, 2) scatter communications, where tropo-scatter offers the greatest possibility, 3) passive satellites, 4) space probes, 5) radar, 6) passive radiometry, and 7) radio astronomy.

A few of the major problems which must be overcome in order to make the maser practical are: 1) compact refrigeration, which can be unattended for

more than a day, 2) compact, lightweight, and adjustable magnets, and 3) overload protection devices, for radar applications. Progress on these items indicates that practical solutions are almost at hand. Workers have reported the design of compact liquifiers with capacities up to 1 watt, operating at 4.2°K. Tunable magnets have been built by a number of workers; one novel approach appears to be a permanent magnet with superconducting trimmer coils, operated in the helium bath. In the area of protection devices, two techniques have been successfully reported: a semiconductor avalanche-breakdown switch, a ferrite limiter.

THE FUTURE: MICROWAVES VS. LIGHT

Now that optical-maser oscillators will soon become available, it is imperative that the relative merits of microwave vs. light be examined for such critical future needs as, for example, space communications. The light maser certainly has the advantage of great focussibility, as determined by $(D/\lambda)^2$, where D is the diameter of the antenna and λ is the wavelength. If the normal large ground structures are used, the factor is about 100 in favor of the theoretical limit of the light maser.

There are, however, three factors in favor of microwave links: 1) freedom from absorption conditions in the atmosphere, 2) power availability, which ap-

pears to be 1000 times above a future projection of the light maser in cases where the power station is earth-bound, and 3) the fundamental consideration that detection is ultimately limited by quantum fluctuations in the number of incoming photons. If N photons are received in a receiver response time, the statistical noise is \sqrt{N} . Because light quanta are about 10^4 to 10^6 times as energetic as microwave quanta, there is 100 to 1000 times less noise in receiving microwave power as compared to the same amount of energy received as light. Although further development of light masers will no doubt result in important applications, this tremendous noise advantage means that the microwave frequencies (and microwave masers) will be increasingly important in the space age, with its requirements for ever-longer-range systems.

BIBLIOGRAPHY

To supplement the broad treatment given herein, more-detailed technical information on masers can be found in references 2, 3, and 4 below.

1. N. Bloembergen, "Proposal for a New Type of Solid State Maser," *Phys. Rev.*, 104, 324, 1956.
2. J. P. Wittke, *Proc. IRE*, 45, 291, 1957.
3. J. Weber, *Rev. Mod. Phys.* 31, 681, 1959.
4. G. Troup, *Masers*, John Wiley and Sons, 1959.
5. DeGrasse, *The Bell System Technical Journal*, 38, 311, 1959.

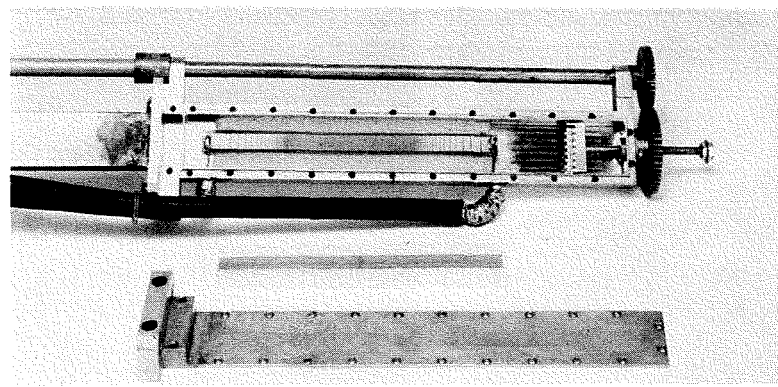
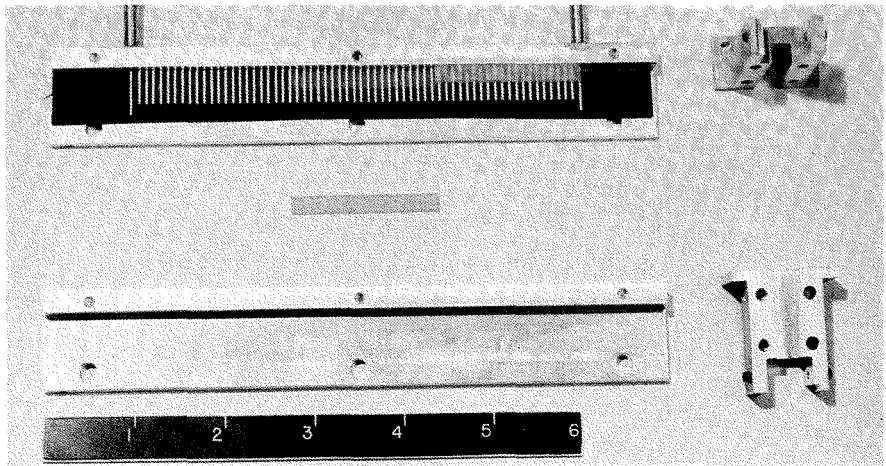

Fig. 5—Meander line mounted in pump cavity.

Fig. 6—Comb structure, an array of quarter-wavelength resonant rods.



NEW, RUGGED, CERAMIC PENCIL TUBES FOR CW USE AT UHF

by L. P. DeBACKER and C. J. GURWACZ

Electron Tube Division
Harrison, N. J.

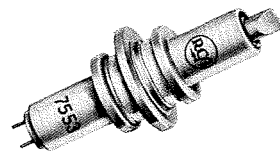

Fig. 1—RCA ceramic-metal pencil tube, about actual size.

TWO NEW ceramic-metal pencil tubes have been developed to meet the stringent requirements of the vhf and uhf fields of communication, telemetering, detection, and guidance. The RCA-7553 is designed for use as a small-signal amplifier at frequencies up to 1500 Mc. The RCA-7554 is intended for class C amplifier and frequency-multiplier service up to 1000 Mc and for cw oscillator service up to 4000 Mc. Both tubes are particularly well suited to applications in which small size, rugged design, high efficiency, and excellent stability are prime considerations. They are convenient to handle, and are adaptable to either lumped or coaxial circuits.

DESIGN FEATURES

The over-all length of the ceramic-metal pencil tubes is approximately $1\frac{1}{2}$ inches, and the diameter is only $\frac{9}{16}$ inch at the grid flange. The plate and cathode terminals are $\frac{1}{4}$ -inch cylinders extending outward from opposite sides of the grid flange (Fig. 1). Heater leads are brought out through a ceramic button stem which is sealed into the cathode end of the tube. All electrode surfaces are silver-plated to reduce the build-up of contact resistance during high-temperature operation and to enhance the high-frequency performance of the tube.

The use of ceramic insulators between elements provides many advantages in tube manufacture and performance:

1) High-Temperature Processing.

During manufacture, the tubes can be baked out at temperatures considerably higher than normal operating temperature to minimize the evolution of gases and other impurities when the tube is placed in service.

2) Rugged Tube Structure.

Ceramic insulators are far less susceptible to mechanical or thermal shock.

3) Radiation Resistance.

Ceramic tubes are affected less by nuclear radiation than either glass tubes or semiconductor devices.

The size and shape of the tubes provide the desirable balance between small size and ease of adaptation to either coaxial or lumped-constant circuit configurations. In coaxial circuits, the plate

and cathode cylinders become extensions of their respective inner transmission lines within the cavities, and the grid flange serves as a barrier which isolates the input from the output circuit. In this type of circuit, the tube actually occupies a space no longer than $\frac{1}{2}$ inch because connections to the plate and cathode can be made right up to the shoulders of these elements. The large surface contacts between the tube elements and the external circuit minimize undesirable lead inductances. In addition, the relatively large plate-cylinder surface allows for rapid and efficient heat removal from the tube by conduction—a significant advantage in compact equipment. Heater sockets, lumped-circuit sockets, and coaxial cavities for these tubes are commercially available.

The grid of these tubes employs a new design concept which allows high performance without critically close grid-to-cathode spacings. In a conventional grid, lateral wires are wound on the outside of the grid siderods. In the new grid design (Fig. 2), the lateral wires are wound on the inside of the siderods. This inside-out grid configuration moves the electrical influence of the grid closer to the cathode without appreciably decreasing the physical spacing between the two elements or weakening the mechanical structure of the grid. The grid-support wires are made of silver-plated copper to provide efficient heat transfer, and the grid-lateral wire is made from gold-plated tungsten to provide strength

LUCIEN P. DeBACKER (left photo) received a B.S. in Physics from the University of Georgia in 1954 and an M.S. in Industrial Engineering from Stevens Institute in 1958. He was in the U.S. Navy from 1949 to 1952 and joined RCA as a specialized engineering trainee in 1954, subsequently assigned to the receiving-tube activity. He is currently an Engineering Leader of Pencil Tube Design and Development in the Microwave Engineering activity at Harrison. He has written several papers and has submitted nine patent disclosures. He is a member of the Sigma Pi Sigma, honorary physics fraternity.

CHESTER J. GURWACZ (right photo) served in the U.S. Navy from 1943 to 1946, and joined the RCA Service Company in 1948. From 1953 to 1955 he was Field Service Manager in the Newark office. He transferred to the Receiving-Tube activity in 1955, and worked as an Applications Engineer on uses of premium industrial tubes and uhf pencil tubes. He is presently a Systems and Applications Engineer in the Microwave Engineering activity at Harrison. Mr. Gurwacz has been attending Fairleigh Dickinson University since 1955, majoring in Electronic Engineering.

and reduce the tendency for primary grid emission. Lateral wires are brazed to the siderods at each junction to provide added grid structural rigidity.

The use of coaxial elements provides many desirable mechanical and electrical features in these tubes, including:

1) Cylinders are inherently strong and machineable to great accuracy.

2) Cantilever arrangement of the elements achieves long leakage paths in close-spaced tubes. In addition, the grid flange effectively shields the ceramic insulator between the grid and cathode, and the plate cylinder is brought down close to the grid flange to shield the other ceramic insulator from the active area of the cathode.

3) Both cathode and grid expand radially in the same direction during warm-up and, as a result, tend to maintain their relative spacings. Longitudinal expansion of these elements has no effect on their relative spacings.

4) Even after the grid and cathode have been mounted in the tube, the accuracy of their line-up and spacing can readily be checked by visual inspection before the plate insert is installed.

5) The cantilever construction also contributes to mechanical ruggedness. Tubes are now being made which withstand longitudinal accelerations of 10,000 g's and vibrations directed perpendicular to the axis of the tube from 2 to 5000 cps at 30 g's with no adverse effects on tube performance.

Another feature of these tubes is the ease with which heat can be removed from the plate during high-temperature operation. Cooler operation of the grid and plate minimize the likelihood of primary emission from these elements or of cathode deactivation due to gases and other contaminants evolved within the tube. The large contact surface provided on the plate terminal allows these tubes to be operated at very high ambient temperatures.

ELECTRICAL CHARACTERISTICS

Table I lists the maximum CCS ratings and average class A characteristics of the 7553 and 7554. Both tubes are ca-

Fig. 2—Inside-out grid construction.

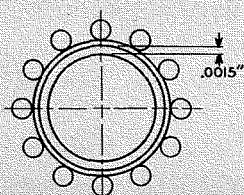

Table I — Maximum CCS Ratings and Class A Amplifier Characteristics of RCA Ceramic-Metal Pencil Tubes

Maximum CCS Ratings — RF Amplifier and Oscillator	
D-C Plate-to-Grid Voltage	250 volts
D-C Cathode-to-Grid Voltage	50 volts
D-C Cathode Current	25 ma
D-C Grid Current	6 ma
Plate Dissipation	2.5 watts
Altitude	100,000 feet
Plate-Seal Temperature	225°C
Peak Heater-Cathode Voltage	50 volts

Average Characteristics—Class A Amplifier

	7553	7554
Heater Voltage	6.3 ± 10% volts	
Heater Current	0.225 ampere	
Plate-Supply Voltage	125 volts	
Cathode-Bias Resistor	50 ohms	
Amplification Factor	80	70
Plate Resistance	6150	4400 ohms
Transconductance	13000	16000 μmhos
Plate Current	12.5	14 ma
Cathode Warm-Up Time	12	12 seconds

pable of operation at altitudes up to 100,000 feet without pressurization and are rated for continuous service at plate-seal temperatures up to 225°C. In *press-to-talk* and portable battery-powered equipment, where fast warm-up and power consumption are very important, these tubes require less than 0.2 watt-minutes of power to be operable.

Because the cylindrical cathode of these tubes surrounds the heater, the most stable and efficient use is made of heater power. During manufacture, 7553 tubes are tested for noise factor and gain at a heater voltage of 6.3 volts. Heater voltage is then reduced by 10 percent (to 5.7 volts) and tubes are limited to a maximum allowable increase in noise factor of 0.5 db and a maximum allowable decrease in gain of 1.0 db. Type 7554 tubes are limited to a 0.2-watt reduction in output in a 550-Mc power amplifier for a 10-percent reduction in heater voltage.

PERFORMANCE OF TYPE 7553

The 7553 is intended for use as a low-noise, high-gain r-f amplifier in receiver input circuits at frequencies up to 1500 Mc. Fig. 3 shows the gain of this tube as a function of frequency for several bandwidths. Although narrow bandwidths may be unrealistic in practical circuits, gains in this range give an indication of the capabilities of the tube.

The tube noise factor as a function of frequency is shown in Fig. 4. The high gain of the tube minimizes the noise contributions of subsequent stages to the system noise factor. At 450 Mc, for

example, a matched-system noise factor of 7.2 db can be realized for a 16-db crystal in series with the tube.

The optimum tube noise factor usually does not occur with the same input termination that gives maximum gain. Fig. 5 shows the matched and optimized noise factors at 500 and 1000 Mc as a function of bandwidth. The difference in the slopes of the two curves is caused by feedback in the tube which alters the input admittance as the bandwidth is varied. This tube represents a balance between the desired amplification factor, feedback capacitance, and output capacitance.

PERFORMANCE OF TYPE 7554

The 7554 is intended for class-C cw oscillator service at frequencies up to about 4000 Mc. Consequently, it should find use as a local oscillator in L-band and S-band receivers and transmitters, in signal generators, as a pump for parametric amplifiers, and in a variety of airborne equipments requiring stable, long-life performance over wide ranges of operating conditions. As a grounded-grid cw oscillator, it is capable of delivering power outputs from about two watts at 500 Mc to about 100 mw at frequencies above 3000 Mc. Commercial cavities designed for use with this tube over its entire range of operating frequencies are available.

The 7554 is also rated as a class C amplifier and frequency multiplier up to frequencies well above 1000 Mc. Fig. 6 shows the performance that can be expected in amplifier or frequency-multiplier service to 500 Mc. Fig. 7 shows the 7554 performance at 1000 Mc. At this frequency, the tube provides about 7.2 db of gain as an amplifier, 4.5 db as a frequency doubler, and somewhat less than unity gain as a frequency tripler. Amplifier data were obtained with a coaxial cavity in both input and output circuits; frequency-multiplier data were measured with a lumped-constant input circuit and a coaxial output circuit.

SUMMARY

The 7553 and 7554 are the first types in a new family of metal-ceramic pencil tubes. The break-through in performance characteristics achieved with these tubes has been made possible through new concepts in fabrication and assembly techniques. New developments now under way hold promise of further improvement in performance, particularly with respect to higher power, higher frequency, and increased life and reliability.

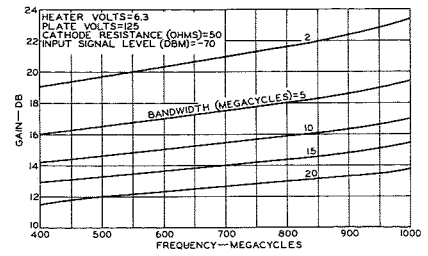

Fig. 3—Gain of 7553 vs. frequency.

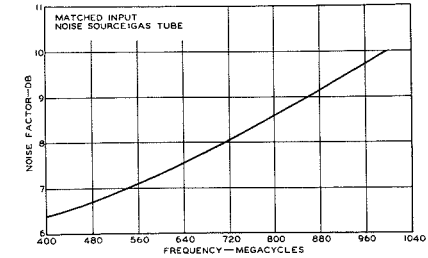

Fig. 4—Noise factor of 7553 vs. frequency.

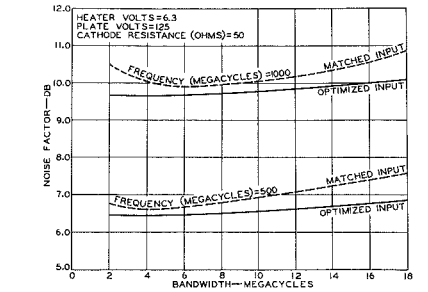

Fig. 5—Matched and optimized noise factors of 7553 vs. bandwidth

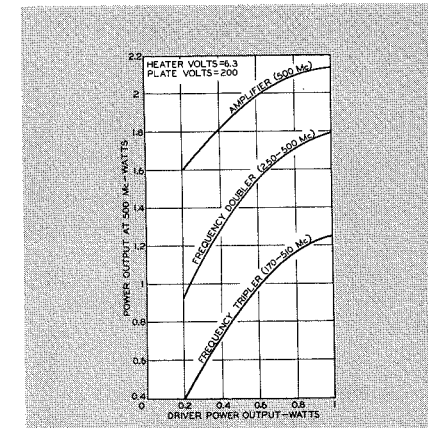

Fig. 6—The 500-Mc performance of 7554.

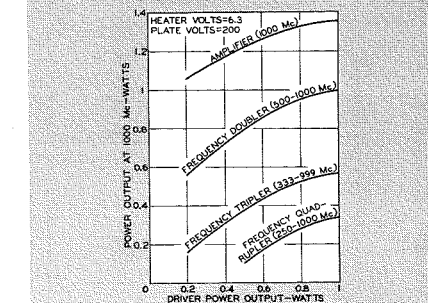

Fig. 7—The 1000-Mc performance of 7554.

The David Sarnoff



RCA Honors Scientist, Engineer and Two Teams

RCA has conferred its highest technical honors, the four *David Sarnoff Outstanding Achievement Awards* for 1961, upon a scientist, an engineer, a research team of two scientists, and an engineering team of five engineers. The awards, announced by Dr. Elmer W. Engstrom, Senior Executive Vice President, each consist of a gold medal, a citation, and a cash prize.

The David Sarnoff Outstanding Achievement Awards in Science and in Engineering were established in 1956 to commemorate the fiftieth anniversary in radio of Brigadier General David Sarnoff, RCA Chairman of the Board. The two awards to individuals have been made annually to one scientist and one engineer.

The two awards for team performance were established last year to augment the individual honors, and are being conferred for the first time in 1961. The importance of such team efforts was especially evident in the many excellent engineering-team nominations that were submitted to the Selection Committee for this inaugural 1961 team award. According to Dr. Engstrom, the addition of team honors "recognizes that many scientific and engineering contributions of basic importance are being made today by teams of creative people who supply the varied special talents so essential to our continued technical progress."

SELECTION CRITERIA

All engineering activities of RCA Divisions and subsidiary companies are eligible for the Engineering Team Award; their Chief Engineers may present nominations for the team award annually—just as for the individual award. Similarly, members of the Research Staff of the RCA Laboratories are eligible for the science awards; nominations are made by the Research Directors.

The Selection Committee for both the individual and team awards in engineering includes: the Senior Executive Vice President, Chairman; the Vice President, Engineering; the Staff Vice President, Product Engineering; the Director, Communications Engineering; and the Vice President, Personnel.

The Selection Committee for both the individual and team awards in science consists of: the Senior Executive Vice President, Chairman; the Vice President, RCA Laboratories; the Director of Research, RCA Laboratories; and the Vice President, Personnel.

The 1961 Individual Awards for Science and Engineering



DR. DWIGHT O. NORTH

... a Fellow of the Technical Staff, RCA Laboratories, Princeton, N.J., is recipient of the 1961 David Sarnoff Outstanding Achievement Award in Science... "for insight in interpreting the role of the theorist at RCA Laboratories and for resourcefulness in translating theory into practical results."

DR. NORTH is widely known for a continuing series of basic contributions to both the method and content of modern electronics research. His studies of noise phenomena in vacuum tubes have led to fundamental improvements in this basic element of electronic communications. As a theoretical physicist at RCA Laboratories, he led some of the earliest fundamental studies of solid-state electronics, and fostered the growth of what is now recognized as one of the most effective theoretical research groups among industrial laboratories. During the past decade, his research has provided a foundation for major advances in such fields as luminescence, thermoelectric cooling, and the tunneling effect that occurs in the tunnel diode.



WAYNE PORTER

... a Systems Engineer, BMEWS, at the RCA Missile and Surface Radar Division, Moorestown, N.J., is recipient of the 1961 David Sarnoff Outstanding Achievement Award in Engineering... "for development and implementation of the means by which the Ballistic Missile Early Warning System (BMEWS) discriminates between missiles and other space objects, thereby improving materially the defenses of this nation and the free world."

MR. PORTER is a systems engineering specialist in the field of radar as applied to detection and guidance of missiles and space craft. His work since 1958 on the far-ranging BMEWS project has been largely responsible for the effectiveness of the system in providing early and reliable warning of the approach of enemy intercontinental missiles. His major contribution has been the complete formulation of the testing and computing procedures that enable BMEWS to distinguish swiftly and automatically between dangerous missiles and the many natural and man-made objects moving in space.

Outstanding Achievement Awards

The 1961 Inaugural Team Awards for Science and Engineering

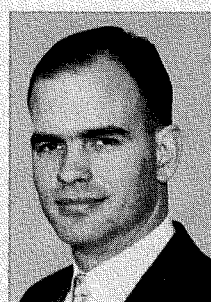
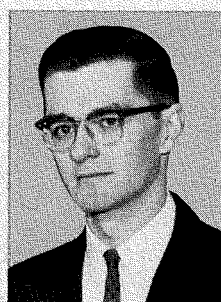
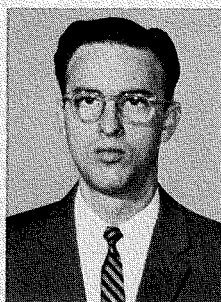
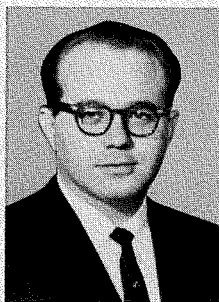

SAUL B. DINMAN, JOSEPH F. CASHEN, GARDNER C. HENDRIE, GRANT D. RUMMELL, AND LAWRIE W. HONENS (L. TO R.) . . . members of the Design Engineering Group, RCA Industrial Computer Systems Department, Natick, Mass., are recipients of the 1961 David Sarnoff Outstanding Team Award in Engineering . . . *"for team performance in the application of advanced system concepts and practical engineering to the successful design of the RCA 110 industrial control computer."*

MESSRS. DINMAN, CASHEN, HENDRIE, RUMMELL, AND HONENS were the members of a design engineering group which was responsible for the development in less than a year of the new RCA 110, a system which is now regarded as the unquestioned leader for such applications as the automatic control of complete industrial processes. The group functioned under the leadership of Mr. Hendrie. Since the completion of their task on the 110, the various members of the group have assumed new responsibilities as individual leaders and participants in a variety of other important computer projects.



DR. HAROLD B. LAW AND DR. EDWARD G. RAMBERG (L. TO R.)

. . . both Fellows of the Technical Staff at the RCA Laboratories, Princeton, N.J., are recipients of the 1961 David Sarnoff Outstanding Team Award in Science . . . *"for team performance in making basic and practical contributions to the science of electron optics."*

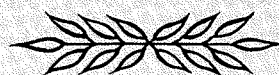

DRS. LAW AND RAMBERG are both known for a number of individual and joint contributions in the field of electron optics, particularly in relation to television. Dr. Law has won wide recognition for his specific contributions in pickup and display tubes for television systems, including participation in the development of the image orthicon camera tube and his development of the method employed in making the phosphor screen of the color television picture tube. Dr. Ramberg has been responsible for major advances in several aspects of electron optics, including electron microscopy. The team award has been based upon his contributions as a theoretical scientist, combined with those of Dr. Law as an experimental scientist, in the investigation and development of electronic display tubes, particularly television kinescopes.

PLASMA PHYSICS

Part 1 — Natural Phenomena and Thermonuclear Fusion

by **Dr. M. P. BACHYNSKI, Director**

Microwave Laboratory

Research Laboratories, RCA Victor Co., Ltd., Montreal, Canada



Studies of plasma physics phenomena are becoming increasingly important in many fields—from work on control of thermonuclear fusion, to microplasmas in semiconductor crystals. In the next issue (April-May 1961) Dr. Bachynski will conclude this survey with plasma effects on communications, plasma propulsion, plasmas in practical electron devices, and some future prospects.

LITTLE DID prehistoric man realize, as he watched the sun, lightning discharges, the Aurora Borealis, or even his open fire that he was observing plasma phenomena. Only in recent time has it become evident that the principal state of matter of the Universe is neither solid nor liquid nor gaseous, but *plasma*—a system including many free electrons and ionized atoms whose mutual interactions markedly affect its properties. This fourth state of matter probably comprises more than 99.9 percent of the matter in our Universe.

BACKGROUND OF PLASMA STUDIES

Although an ideal plasma could readily be created in the laboratory many years ago in the form of a partially ionized gas, such investigations were not pursued very actively, since the techniques for controlling a plasma were in a primitive state and it appeared that they bore little relation to phenomena occurring on the earth. Consequently, the astrophysicists who realized the role played by ionized matter in Galactic processes were left unmolested in their ivory towers to make some of the earliest and most significant contributions to plasma physics.

The hydrogen bomb opened the search for techniques of controlling the thermonuclear-fusion reaction for generation of electrical power, while attempts to thrust further and further into space were confronted by communications and guidance problems involving plasma-physics phenomena. Even the problem of propulsion in space itself has become a branch of the subject. As a result, plasma physics has become one of the most intensely investigated fields of science.

PLASMAS IN NATURE—THE SUN

The sun and its activities are plasma phenomena. The visible part of the sun, or the solar atmosphere, can be considered to consist of three layers.

The *photosphere* comprises the visible disk, which is a few hundred kilometers thick. Present-day knowledge attributes an average particle density of $10^{16}/\text{cm}^3$ to this region, with a free-electron density of 10^{12} electrons/ cm^3 .

Surrounding the photosphere is a reddish ring approximately ten thousand kilometers thick above which flame-like prominences rise. This is the *chromosphere*, a very inhomogeneous region consisting principally of hydrogen, helium, and calcium, which radiate energy due to electron-proton recombination and excitation of the light elements.

Surrounding the chromosphere and extending millions of kilometers into space is a thin, hot atmosphere, the *corona*. The corona is very tenuous—stars are visible through it and comets traverse it unaltered. A steep temperature gradient extends from the chromosphere to the hotter corona, where temperatures exceeding 1 million °K exist (Fig. 1). Although almost all known elements are seen in its spectrum, the presence of fully ionized hydrogen and helium ions is of prime significance.

It is now considered that the self-sustaining action of the sun is that of a huge thermonuclear device which releases energy by fusing together protons to form neutral helium atoms:

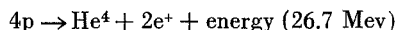

This process proceeds at a slow rate, establishing temperatures in the interior of the sun exceeding 20 million °K. Because of the large mass of the sun, the force of gravity is sufficient to prevent the escape of all but the most energetic charged particles (plus radiation).

The Ionosphere

As the ionizing radiation from the sun (principally ultraviolet and x-ray radiation) penetrates deeper and deeper into the atmosphere of the earth, it encounters a larger and larger density of gas particles. As a result, the radiation produces more and more electrons per unit volume. However, in this process the radiation is absorbed so that a position is reached where the rate of absorption of the radiation is greater than the rate of increase of the atmospheric density. Consequently, the rate of production of electrons decreases as lower altitudes are reached. Hence there exists a height

DR. MORREL P. BACHYNSKI graduated in 1952 from the University of Saskatchewan with the B. Eng. in Engineering Physics, receiving the *Professional Engineers of Saskatchewan* prize for the highest scholastic standing in his graduating class. In 1953, he obtained his M. Sc. in Physics at the University of Saskatchewan in the field of radar investigations of the aurora. He then joined the Eaton Electronics Research Laboratory, McGill University, where he was awarded a Ph.D. in 1955 with a thesis on aberrations in microwave lenses. He remained at the Eaton Laboratory carrying out research on the imaging properties of nonuniformly illuminated microwave lenses, including phase investigations at the Air Force Cambridge Research Center. In October 1955, he joined the Research Laboratories of the RCA Victor Company, Ltd. Since this time he has conducted research on wave propagation, diffraction, reflection, obstacle gain, radome design, antennas, microwave techniques, shock-front structures and plasma physics. Dr. Bachynski is a Senior Member of the IRE, a Member of the Canadian Association of Physicists, and the Canadian National Committee of URSI (Commission VI).

which depends on the gas density gradient and the absorptivity of the radiation where electron production is greatest.

By this process, a great natural blanket of plasma, the *ionosphere*, which envelops the earth from an altitude of approximately 70 to over 300 kilometers, is produced. The various layers of the ionosphere (D, E, F in order of increasing altitude and also electron density) represent regions of ionization ranging from 10^4 to 10^6 electrons/ cm^3 each merging into the next higher region without pronounced minima. (An accurate, detailed explanation of the formation of the ionosphere is not yet available, although gross features are known.)

van Allen Belts

In addition to the ionosphere, whose existence has been known for some time, recent satellite experiments have discovered other plasma effects due (at least in part) to radiation from the sun. These are the van Allen radiation belts (Fig. 2) in which high-energy charged particles (principally electrons and protons) are trapped in regions where they execute complicated trajectories which spiral to and fro along geomagnetic lines of force across the earth's equator and at the same time drift slowly around the earth. The net result is an electric current associated with the belts which should slightly modify the magnetic field at the earth's surface. Particles can

escape from the belts by collision with the atmosphere and recombination to form neutral particles. Because of this slow loss, the radiation regions are maintained only as a result of a continual replenishment of particles.

Completely different origins are attributed to the two radiation belts. (The data from Pioneer V indicates a third radiation region surrounding the earth at a distance of 8 to 10 earth radii). The inner belt is ascribed to cosmic rays which penetrate into the atmosphere forming proton-electron pairs that are trapped by the magnetic field of the earth and maintained in the belts. The outer belt is thought to be due to and maintained by streams of neutral plasma consisting mainly of protons and electrons which are ejected from time to time by the sun. This belt changes considerably in extent and intensity depending on the solar activity. These streams are considered to be ejected at very high velocities (1000 km/sec) so that the particles are confined by the magnetic fields associated with such intense electric currents.

Solar Disturbances

At times, the chromosphere becomes turbulent and sunspots appear.

The result of the solar eruptions is an enhanced discharge of strongly electrified particles from the surface of the sun forming strong plasma whose fields and particles permeate interplanetary space. Simultaneously, intense ultraviolet and x-ray radiations are emitted which enhance the normal ionization of the earth's atmosphere. The stream of ejected particles travel into space and on occasion are intercepted by the earth. When this happens, about a day after the solar eruption, a *geomagnetic storm* resulting in sharp fluctuations in the strength and direction of the earth's magnetic field occurs. These streams of plasma are able to find their way into a circular zone around the geomagnetic poles (the auroral zone) where electric currents of millions of amperes are generated. This seriously distorts the normal magnetic fields around the polar regions causing the incoming particles which produce aurorae to spread further and further southward. Finally, the particles become trapped in the outer van Allen radiation region, forming a ring current about the equator which falls off slowly and in a few days attains its normal value.

At times of sunspot maxima, particularly violent solar eruptions with the projection of hot fireballs of material into space are also known. These explosions give rise to the arrival of energetic particles at the earth in about one to four hours after the event and long before the slower but more intense main stream of plasma. The density of particles is

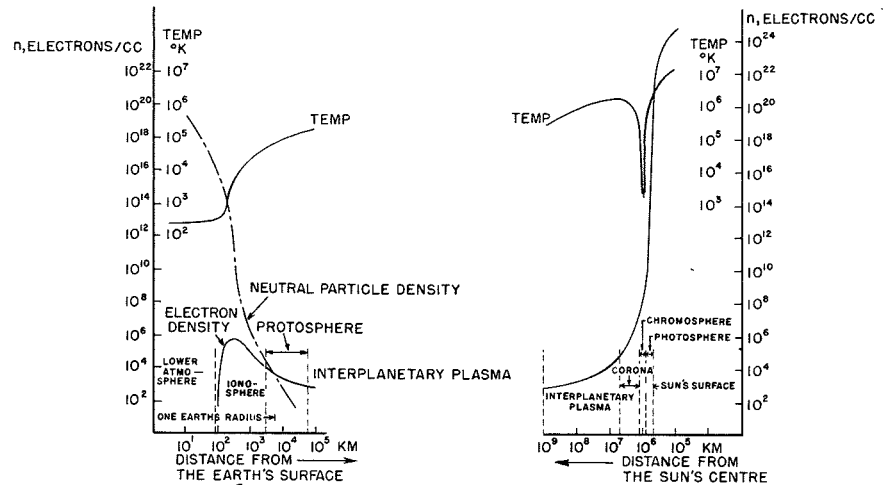

Fig. 1—Plasma between earth and sun.

insufficient to distort the earth's magnetic field, but the particles enter into the polar cap following along the almost vertical magnetic field lines where they cause a prompt radio black-out.

THERMONUCLEAR PLASMA

By modifying the structure of certain nuclei, energy may be released.

In one method—*fission*—the energy arises from the splitting of *heavy* nuclei into lighter fragments. Fission creates a net energy yield because the mass of the original nucleus is greater than the sum of the masses of the fragments after fission has occurred. An alternate method—*fusion*—is the combination of certain light nuclei into heavier components whose mass is less than the sum of the masses of the original constituents.

The Fusion Process

Of the light elements, the two isotopes of hydrogen—*deuterium*, one proton and one neutron, and *tritium*, one proton and two neutrons—appear among the leading candidates as fuels for fusion reactions. Hydrogen, itself, is not practical, since its rate of fusion is much slower than either of its two isotopes under the same conditions. Reactions of principal importance for these constituents are:

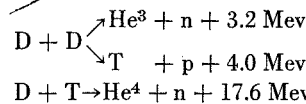

In each case, energy is released and although this energy is appreciably less

than that released in a fission reaction, the energy per unit mass of fuel is greater from fusion than from fission. The fusion products are nonradioactive, and hence present no disposal problems. Furthermore a controlled fusion device offers the possibility of direct generation of electric power by the elimination of the inefficient heat cycle.

For fusion to occur, the particles must approach sufficiently close to each other for long enough time that the short-range nuclear forces interact causing the nuclei to fuse. This is the so-called *thermonuclear reaction*. Because of the positive charge on the nuclei, the particles tend to repel each other strongly. In order to overcome these coulomb forces, the particles must be made to collide at high velocities corresponding to temperatures of the order of 10^8 °K (for a Maxwellian distribution of particle energies). At such temperatures, attainable only in gases, the gas is fully ionized, consisting of ions and free electrons—i.e. a *plasma*. Thermonuclear research is thus concerned with the confinement, heating, and diagnostics of very-high-temperature plasmas.

Confinement

One of the major requirements for thermonuclear fusion is a means to contain the hot plasma in a given volume for a sufficient length of time such that an appreciable portion of the nuclei will fuse together.

Solid material containers are of no value for this purpose because of the cooling effect on the plasma when it comes into contact with the walls and the consequent quenching of the reaction. It is thus necessary to use a force which acts at a distance such as gravitational or electric or magnetic fields. For

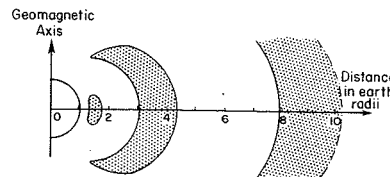

Fig. 2—Van Allen natural radiation zones.

masses of the size encountered in laboratory experiments, gravitational forces are much too weak to be of practical use (although these are precisely the forces which are effective in confining the plasma particles in the sun and other large stellar masses). Static electric fields act in opposite directions on positive ions and electrons causing charge separation which creates opposing fields, making this method ineffective. The only plausible schemes are those involving magnetic fields (either static or slowly varying in time) and possibly combinations of r-f and magnetic fields.

The Pinch Effect

One of the earliest schemes suggested for plasma confinement is the *pinch* effect. It is based on the principle that a current flowing in a conductor produces its own magnetic field which encircles the current (Fig. 3a). This magnetic field exerts an inwardly directed force which tends to constrict, or pinch, the conductor. A high-temperature plasma is a very good conductor (its resistance can be many times lower than that of copper), so that in the pinch confinement the current is made to flow in the plasma itself. As the current builds up, its associated magnetic field increases in strength and in turn pinches the plasma into a dense, hot region in the center of the container.

The pinch devices need not be linear in configuration. In fact, in order to eliminate end losses, one of the favorite configurations is the torus. ZETA—the British machine at Harwell—is an example of a toroidal pinch device.

Unfortunately, highly constricted columns of plasma are unstable against forces which distort its shape, and any initial disturbances tend to grow in amplitude so that the column rapidly disintegrates. It has been demonstrated that the presence of a longitudinal magnetic field within the plasma current discharge has a stabilizing influence which inhibits the formation of small kinks. In addition, theory predicts that external conducting shells may also assist in controlling the instabilities. A great deal of investigation still remains on such schemes.

Magnetic Mirror

The use of a straight section of tube to contain a thermonuclear plasma requires some suitable technique for stoppering the ends of the container. One approach is to wind magnetic field coils about a straight section of tube so as to produce an axial magnetic field which is weak in the central region, but strong at the two ends (Fig. 3b). The strong fields at the ends tend to repel the charged particles of the plasma and hence tend to move them back towards the central region. These strong fields at the ends, which

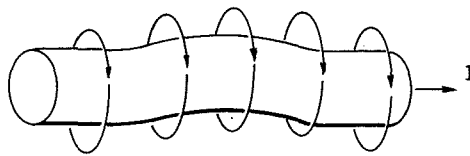

a. PINCH: A current in a column of plasma creates an encircling magnetic field which exerts an inward force on the charged plasma particles and hence pinches them to the center.

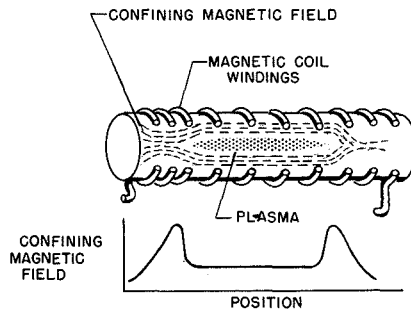

b. MAGNETIC MIRROR: Current-carrying coils are wound on a cylinder to produce strong magnetic fields at each end. The plasma can then be trapped between the two end mirrors.

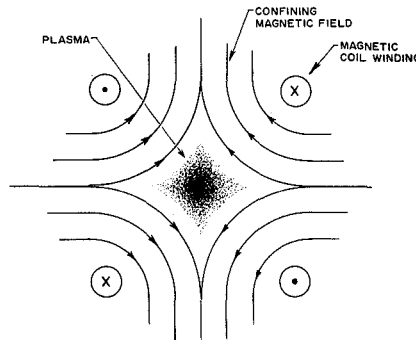

c. CUSP GEOMETRY: By suitable arrangement of magnetic field coils, cusp configurations of confining magnetic fields are possible.

Fig. 3—Ways of confining thermonuclear plasma.

trap the particles, thus constitute the *magnetic mirrors*.

The requirement for containment of plasma particles by a magnetic mirror is that the particle energy in the axial direction be small compared with its energy in the perpendicular direction. If the axial velocity of the particle is too great, the mirror fields will not turn the particle back and hence it will escape. This creates the problem of how should the particles be injected so that trapping by the mirrors will occur. Suggested schemes include the injection of beams of low-energy ions which are given large perpendicular accelerations by r-f electric fields as they pass slowly through the central mirror region, thus giving them sufficient transverse energy to be trapped. A second scheme is to inject a beam of high-energy neutral atoms as molecules and break these up as they pass through the confinement volume,

thus providing a means for continuous reinjection of energetic particles.

A second problem is that the above-mentioned anisotropies in velocity-space required for containment of the plasma in a mirror machine can give rise to instabilities. These instabilities are of two types; one is due to unstable electrostatic plasma oscillations which grow at the expense of the electron energy, and the second is due to unstable hydromagnetic disturbances which cause the confining field to become rippled and to fluctuate rapidly, which in turn gives rise to enhanced diffusion of particles across the field.

The use of mirror machines is thus not without its problems and considerable investigations are yet to be made.

Stellarator Plasma Containment

For the containment of thermonuclear plasmas, the Stellarator uses a magnetic field parallel to the axis of a toroidal tube produced by external currents flowing in solenoidal windings encircling the plasma. The confining fields are such that the magnetic lines of force generate not a single circle but an entire complex helical or toroidal surface suitable for the trapping of plasma particles. Some of the stability problems of the Stellarator are similar to those of the toroidal pinch, although the much smaller currents in the plasma interact less violently with the fields.

Other Containment Schemes

Another approach is based on the idea that as a result of the gyroscopic action, a rotating plasma may be stable. In this *homopolar* device, the application of radial electric and transverse magnetic fields cause the plasma particles to precess about a central axis, creating a centrifugal force which tends to keep the particles away from the axis and trap them in regions of magnetic field caused to bulge by the rotating plasma.

Studies of magnetic confinement indicate that magnetic configurations with lines of force curving away from the plasma should be stable while those curving towards the plasma tend to be unstable. This suggests that configurations in which the magnetic lines of force curve everywhere away from the plasma might be stable. Such a scheme is the picket fence, or cusp, geometry (Fig. 3c). There exists, of course, the problem of "stoppering" the regions of weak confinement. One idea is to use r-f electric fields which are nonlinear in space and thus create a net force on the particles which inhibits their escape. Some consideration has been given to complete systems using r-f gradient fields; however, the required power appears excessive.

A further idea has been to start from the high-energy side, that is with a beam of particles having energies greater than those needed for thermonuclear reactions, and by injecting and trapping them in a confined region, to build up to densities which would sustain the thermonuclear reactions. To achieve this it is necessary to inject a high-energy beam of particles into a strong magnetic field and to dissociate the particles before they come out. Many other schemes are under investigation.

Heating

A crucial requirement for any thermonuclear machine is the means to heat the plasma to the required high temperatures of a hundred million degrees or more. Of the several methods for heating the plasma, the simplest is the ohmic or Joule heating by the currents in the plasma which produce the confining fields. At high temperatures, the power input per unit volume becomes small because of the high conductivity of the plasma, so that interparticle collisions must occur to provide any Joule heating. The collisions however tend to diffuse the azimuthal confining fields and the axial stabilizing field into each other. Thus, the Joule heating requirements and those for stability are contradictory.

Another method of heating the plasma (used in mirror machines) is adiabatic compression. In this technique, the magnetic field strength of the entire mirror configuration is made to increase with time. Thus, particles (ions and electrons) injected into the machine at times of low field strength will increase their transverse energy as the magnetic field is increased while their axial energy will remain the same. In fact, the increase in transverse energy of the particles is directly proportional to the increase in magnetic field strength.

A plasma can also be heated by pulsing the axial confining field so as to produce an oscillating electric field which encircles the axis of the tube. This induced electric field can increase the energy of the gyrating charged particles. Such a method is aptly called *magnetic pumping*. The magnetic-pumping technique is particularly effective if the confining field is pulsed at the cyclotron frequency of the positive ions. This is due to the interaction between the oscillating electric field and the gyrating positive particles which move in the same direction and with the same velocity as the electric field so that resonance coupling is possible.

Of importance in the thermonuclear reaction is any process which might cause more energy to leave the reaction than is created and hence cool the

plasma. Under the assumption of perfect containment, the basic energy loss is due to *bremstrahlung*—radiation from the plasma itself from deflection (through collision) of the rapidly moving charged particles. If the system is to be self-sustaining, the generated power within the plasma must exceed the radiated power. This occurs above a certain critical temperature—the *ignition temperature*. For the D-D reaction, this critical temperature is of the order of 4×10^8 °K. A second form of radiation loss from the plasma that may be important is synchrotron radiation due to the radial acceleration of particles in a magnetic field.

In addition to the radiation losses from the plasma, particle losses will occur. There will always be a number of particles, particularly electrons, in the high energy tail of the velocity distribution of particles in the plasma. These electrons are too energetic to be contained by the normal confining field strength and constitute *runaways*.

Diagnostics—Measuring Thermonuclear Plasma Phenomena

Since thermonuclear plasma research is in a highly exploratory state, a great number of techniques are utilized to diagnose what is actually happening.

Visual diagnostics with fluorescent screens and photographic methods are of value in obtaining qualitative information. Fluorescent screens have been used to determine the location of the plasma, ion orbit size and approximate density measurements. The same information can be obtained with fast-shutter photography, while streak photography enables a display of the time history of the position and light intensity of the plasma.

Spectrographic techniques have yielded much quantitative data, such as determination of the ion velocity distribution from Doppler and Stark broadening of the spectral lines, spectral-line identification of the plasma species and impurities, and determination of electron temperatures by measurement of the intensity ratio of the spectral lines of ionized and neutral species of the plasma. In addition, x-ray energy analysis has been applied to measurement of the radiation emitted from the hot plasma.

Direct-current probe techniques have been used with moderate success (the major difficulty being that probes severely perturb the plasma) to obtain indications of electron temperature, ion and electron densities, and distribution profiles. Current loops and probes are of value for plotting contours of magnetic field and current distributions. Considerable interest has been shown in solid-state probes, based on the Hall effect.

Radio frequency techniques have proven extremely useful, since transmission of microwaves through the plasma yields information on the plasma electron density, while a measure of the intensity of r-f energy emitted from a plasma yields the kinetic electron temperature. Furthermore, resonance absorption at certain r-f frequencies can be used for ion identification, since the gyrofrequency of a specific ion depends on its charge-to-mass ratio. The use of high-frequency radio techniques in plasma diagnostics has in turn stimulated research on the generation of higher and higher frequency coherent electromagnetic energy.

Infrared measurements as thermonuclear diagnostics have been limited due to the slow time response of most long-wavelength infrared detectors. As the time constant of these detectors continues to be improved with the advent of new semiconductor materials and techniques, their utility will increase.

Many techniques first introduced in nuclear particle physics are of great value. Among these are the determination of temperature and velocity of runaway electrons with graded absorbers in front of scintillation counters, similar studies employing nuclear emulsion plates, and the use of neutron counters for detecting neutrons which should arise out of the thermonuclear process but more usually are formed far too prematurely as a result of acceleration mechanisms, such as instabilities.

The Job Ahead

Of the numerous experimental approaches under investigation, none is in a position to achieve the ignition temperatures where the input energy begins to equal the energy generated. Before this is possible, a tremendous amount of basic knowledge of plasma properties is still required. These investigations point only to further clarification of the severe stability requirements, of the important energy loss mechanisms, of the necessary containment times, the techniques of heating and diagnosing plasma and many other problems. All the different approaches are studies of plasma physics necessary to understand the fundamental behavior of plasmas over the widest possible range of conditions. This is being achieved by the use of many relatively small scale experiments devised to test crucial limitations and novel ideas in addition to the large machines which create conditions approaching those in a genuine thermonuclear reaction.

[To be continued in Vol. 6 No. 6, April-May 1961.]



The wheelhouse of the Moore Macpride, showing one steering-stand of the RCA automatic control system. Inset is the gyro-compass. The Moore-Macpride installation, now in service, is a duplicate one—two stands, compasses, and steering engines. It will be followed by six more similar installations.

AUTOMATIC STEERING AND GYRO-COMPASS FOR LARGE SHIPS

by IRVING F. BYRNES
*Communications Products Dept.
 IEP, New York, N. Y.*

THE SIZE AND SPEED of ships reached the stage about 100 years ago where power steering became essential to control the rudder. The first "steering engines" used steam power with suitable mechanisms to convert reciprocating motion to linear travel through ropes or cables on a quadrant attached to the rudder post. Later on, the advantages of a hydraulic system were realized, using oil under pressure to actuate rams and with comparatively small valves to direct the flow of oil. The next step was to control the valves electrically, so that today electrohydraulic steering is common on large vessels.

AUTOMATIC VS. HAND-STEERING

Steering a ship by hand through a

powered system requires little manual effort. But over long periods of time, it is a painstaking job as the helmsman watches the compass heading to maintain the best possible straight course. Automatic steering soon became an obvious objective, and means to tie together the compass heading with power steering were developed.

Electronic devices are well suited for such applications because of their convenience in amplifying small signals and their ability to provide a closed loop servo system. A good magnetic compass, through photo-cells or contact devices, can be used as a heading reference and is so applied on small craft for automatic steering. However, for large vessels the gyro-compass is prac-

tically standard because it provides a very accurate and stable heading reference, not only for automatic steering but also for basic navigation.

Nearly all shipboard gyro-compasses are designed to actuate repeaters so that the ship's heading can be transferred to other devices and used for control or observation. Such devices are the steering stand, radar, direction finder, course recorder and conventional bearing or steering repeaters. In each case the repeater is generally a small "step-by-step" d-c pulsed rotor that moves in steps of one-sixth degree in synchronism with the master gyro-compass. Scales, pointers, or potentiometers can be driven by the repeater. It has high torque and accuracy because of the gearing between the rotor and its output shaft. For a 360°, complete turn of the ship, the rotor makes 180 revolutions.

A large vessel's great mass necessarily involves some delay between a change in the heading and movement of the rudder. It is therefore desirable to start the rudder promptly and to turn it at a fairly high rate in order to minimize the delay and to make the ship handle effectively. At the same time it is important not to under-steer or over-steer. This is where well-designed servo or synchro systems provide excellent control.

Recent developments by manufacturers of steering engines have greatly lowered the torque required to control the valves, or pump-stroke, control device. Such systems require only 2 or 3 inch-pounds of torque and are particularly suited to electronic control. The steering-engine input shaft, in a typical case, makes 18 revolutions to move the rudder 70°, which is the *hard-over* to *hard-over* travel. From a straight-ahead course to maximum right or left rudder, these values are halved, becoming ± 9 turns and $\pm 35^\circ$.

A general specification for the minimum rate of rudder movement is $2\frac{1}{2}^\circ$ per second. This must be measured within less than the full 70° travel, such as over 65°, because of the finite time needed to start and stop the rudder. Since the steering engine itself is a massive unit, it must be designed to accept fast rates of helm angle from the electronic controls without undue strains. This is done by a *storage motion* device on the steering engine. With hand-steering, the wheel can readily be turned at a rudder rate equivalent to 5° or 6° per second, while on automatic control the rate is about 4° per second. Thus, the maximum rate of rudder movement is not limited by the electronic controls.

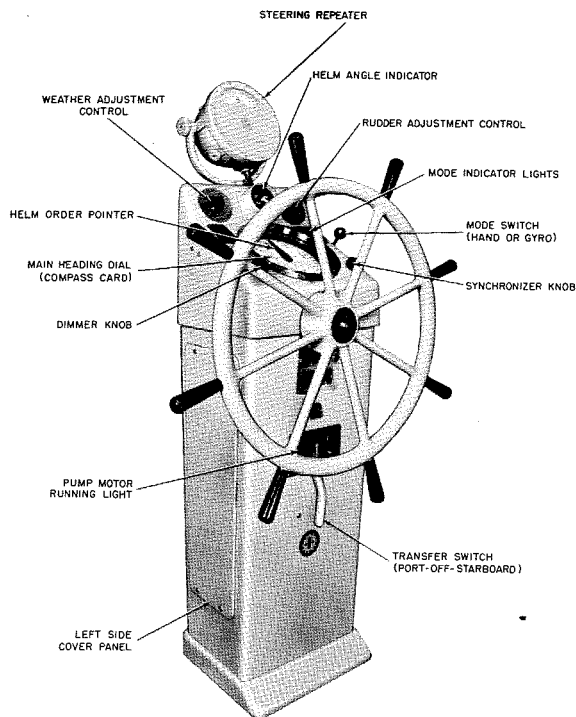

Fig. 1—Steering stand.

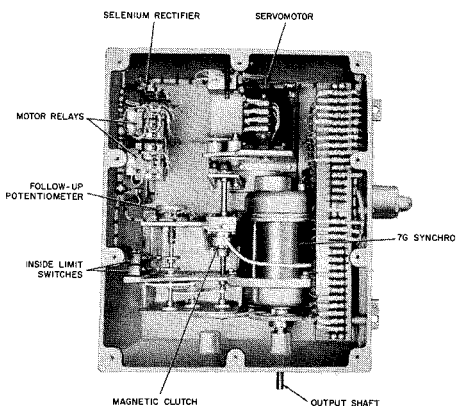

Fig. 2—Rotary actuator.

STEERING CONTROL SYSTEM

The RCA control system comprises two major units, a *steering stand* (Fig. 1) in the wheel house and a *rotary actuator* (Fig. 2) mounted directly on the steering engine. A switch on the stand permits quick selection of hand or automatic steering. For maximum dependability many vessels use duplicate equipment—two stands, two actuators and two steering engines. A mechanically interlocked switch on each stand permits either to be selected. Its associated actuator is then energized. Wiring between pairs of stands and actuators is routed separately and independent power supply is available, all in the interest of reliability.

Hand-Steering

A very simple synchro arrangement is provided for hand steering. Two large synchros (size 7) are used, one in the stand and one in the rotary actuator.

If the wheel is turned to rotate the stand synchro, say one revolution, the actuator synchro will follow and make one revolution of the input shaft on the steering engine. Six turns of the wheel give eighteen synchro turns for 70° of total rudder travel. Because a synchro must lag several degrees to produce a desired torque, it may be questioned whether errors will be harmful. However, since 18 revolutions are equivalent to 6480° and the rudder moves only 70° total, this large ratio of 92:1 swamps out errors. The synchro rotors are connected in parallel between the units in the stand and actuator.

Automatic Steering

Automatic steering involves a fairly complex assembly of electrical and mechanical components to make up a closed loop servo system. All of these



IRVING F. BYRNES has been associated with RCA since 1930. He has held important posts, including Vice President, Engineering, Radiomarine Corp. of America. He entered the General Electric Co. test department in 1918 and was later engaged in radio development in the engineering laboratory. He completed extension courses in Electrical Engineering at Union College, and in 1922 participated in the development and design of early ship-to-shore radiotelephone equipment. He holds several patents for radio devices, and in 1940 received the *Modern Pioneers Award* from the NAM for his contributions to marine radio communication. The U. S. Navy Bureau of Ships awarded Mr. Byrnes its *Certificate of Commendation* in 1947. He is the author of many technical papers on radio equipment, and is a Fellow of IRE. Mr. Byrnes is a member of *RCA Review* Board of Editors and the RCA Institutes Board of Technical Advisors.

components, except for a few gears and shafts are completely independent of the synchro hand-steering system. This is done to ensure maximum reliability so that failure on *automatic* will not impair *hand*, and vice-versa.

A schematic of the principal circuits used for automatic steering is shown in Fig. 3. On a straight heading, the arms of potentiometers R1110 in the stand and R2103 in the actuator are in mid-position, and no signal is delivered to the magnetic amplifier. The output from the rate generator, driven by the gyro-compass, is zero. The differential relay K1100 is at neutral, the right-left relays are de-energized, the servo motor is stopped, and the rudder is held in mid-position.

Now assume that the ship's heading falls off a few degrees. This is recognized by the step motor, which moves the arm of stand potentiometer R1110 to deliver a signal to the magnetic amplifier. The rate generator also sets

Fig. 3—Simplified schematic of the automatic steering equipment.

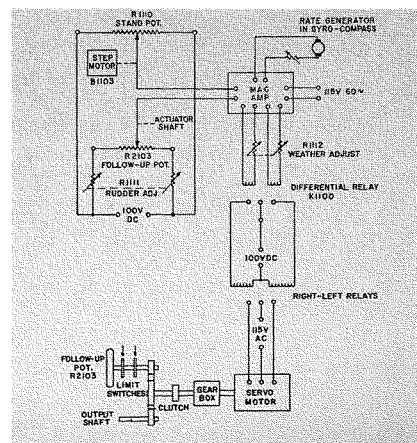

for motor power comes in through the centering pin and mercury at the top of the sphere and phase 2 connects to the pool of mercury at the bottom. The circuit for phase 3 is from graphite rings on the inside of the bowl, then through the conductive fluid, and finally to graphite rings on the outside of the sphere. The sphere shell is brass and is connected in phase 3, with the outside surface insulated by a hard rubber coating except for the areas having the graphite rings. In this novel manner, 3-phase power of about 150 watts drives the wheels while permitting the sphere to take up its north-seeking position with negligible friction.

Error Correction

A single-wheel gyro-compass on a ship that rolls or pitches is subject to errors when the course is at or near 45°, 135°, 225°, or 315°. This is the so-called intercardinal error caused by east-west torques developed by accelerations during pitch or roll. These torques oppose the natural torques from gravity and the earth's rotation and vanish if the course happens to be 90°, 180°, 270°, or 360°. By using dual wheels, suitably linked together, the normal north-south torques become additive, and the east-west torques are cancelled out. In operation, the axes of the two wheels are at an angle of about 15°. The bisector of this angle is on the north-south line.

The gyro wheels and complete sphere assembly are damped by oil-filled tubes that allow the oil to pass slowly from one side to the other during the starting-up period. Without damping, the sphere would oscillate continuously in an elliptical path around the north-south axis. About 4 hours are required for the sphere to settle in its final position; therefore, the gyro-compass is started up before a vessel leaves port.

When the vessel makes a turn or changes course slightly, the sphere remains fixed in space. The surrounding bowl, which is suspended in gim-

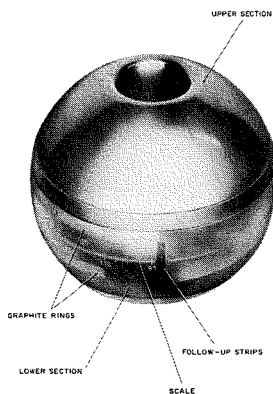

Fig. 7—Gyro-compass sphere.

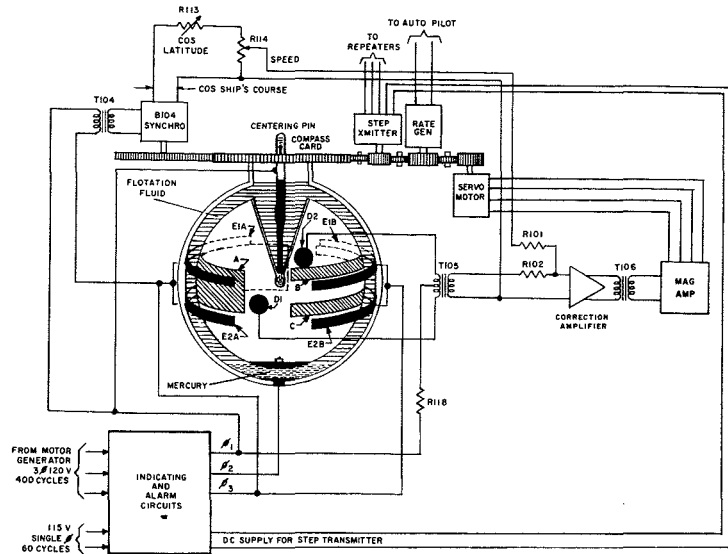

Fig. 6—Gyro-compass basic circuits.

bals and rotatable in ball bearings, will tend to rotate since it is a part of the ship. This is where the follow-up servomechanism comes into action. Referring to Fig. 6, there are two graphite contacts D1-D2 inside the bowl that connect to transformer T105. When the resistance between these contacts is equal with respect to the transformer mid-tap, no error signal exists and the magnetic amplifier delivers no output to the servo motor. When the bowl tries to rotate, the resistance to the pairs of graphite rings on the sphere (through the fluid) will change, starting up the motor and turning the bowl to rebalance the bridge.

The follow-up mechanism also drives the transmitter (pulsar) for the step repeater motors and the d-c rate generator that are connected to the steering stand. A small resolver-type synchro is also in the gear train. This applies a voltage to a transistorized connection amplifier ahead of the magnetic amplifier. Any gyro-compass has a small error that is related to the ship's speed,

latitude, and course. This error is zero when going east or west and increases with latitude and speed on other courses. The resolver automatically feeds in the appropriate correction voltage for course, but requires manual settings on calibrated dials for speed and latitude. These are reset for speed changes exceeding 4 knots or latitude changes over 5°, whenever maximum gyro-compass accuracy is required.

Self Monitoring

Because of the importance of a gyro-compass in navigating a ship, elaborate monitoring circuits are provided to alert wheelhouse personnel in the event of malfunction. Audible alarms and warning lights are provided, powered from a separate battery.

ACKNOWLEDGMENT

Engineering development of the equipment described in this article was a joint undertaking by J. L. Levine, M. Lewson and H. Bonneau of the Belock Instrument Corporation and the author and G. C. Hopkins of RCA.

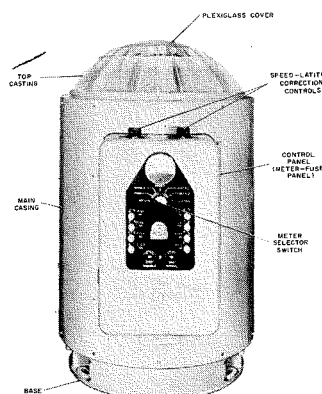

Fig. 8—Gyro-compass equipment.

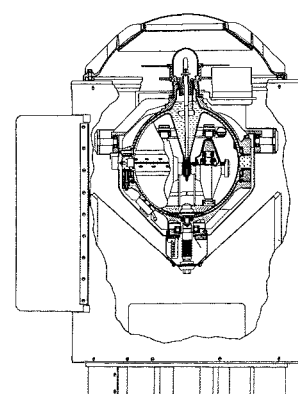

Fig. 9—Cutaway of gyro-compass.

A TECHNIQUE FOR MEASURING SYMMETRICAL MAGNETIC FIELDS

by L. J. BAZIN

RCA Victor Home Instruments

Cherry Hill, N. J.

THE TECHNIQUES described here were originally developed for electromagnetic field measurements of cathode-ray-tube deflection yokes. However, it is possible to apply the equipment for measurements of most types of electromagnetic fields. If a particular symmetry characteristic is present in the field, the number of measurements to adequately describe the field may be considerably reduced. Magnetostatic fields could also be measured, but the stationary-coil probe would have to be replaced with a rotating-coil type. The particular field described was measured to determine electron beam trajectories and deflection aberrations on the screen of a kinescope.

FIELD EQUATIONS FOR A DEFLECTION YOKE

The field generated by a television deflection yoke is composed of two separate fields, one generated by the horizontal deflection coils (Fig. 1) and the other by the vertical deflection coils.

The significant feature of a useful deflection yoke is that it exhibits a mirror type of symmetry; the following relations can be stated about the field components:

QUAD I	QUAD II	QUAD III	QUAD IV
$H_y(x, y, z_1) = H_y(-x, y, z_1)$	$H_y(-x, -y, z_1) = H_y(x, -y, z_1)$		
$H_x(x, y, z_1) = -H_x(-x, y, z_1)$	$H_x(-x, -y, z_1) = -H_x(x, -y, z_1)$		
$H_z(x, y, z_1) = H_z(-x, y, z_1)$	$H_z(-x, -y, z_1) = -H_z(x, -y, z_1)$		

A general expression may then be derived for the field generated by the coils, when the region of deflection is considered free of electric current, charge, and electric field. A method for obtaining the general expression of this particular field has been used by Haantjes and Lubben.¹ Since the $\text{CURL } \vec{H} = 0$ and $\text{DIV } \vec{H} = 0$, a power-series expansion of the field results in the following expressions for the three components of the field, to a third-order approximation:

$$H_y = H_1(z) - \left[H_2(z) + \frac{H_1''(z)}{2} \right] y^2 + H_2(z) x^2 + \dots$$

$$H_x = 2H_2(z) xy + \dots$$

$$H_z = H_1'(z)y - \left[\frac{H_2'(z)}{3} + \frac{H_1'''(z)}{6} \right] y^3 + H_2'(z) x^2 y + \dots$$

Where: $H'(z) = dH(z)/dz$. Good correlation between observed and calculated aberrations has been obtained at deflection angles of 70° with the third-order approximation. The significant feature is that the field can be adequately expressed by measuring only two functions of z , thereby reducing the complexities of measurement and calculations. These are the $H_1(z)$ and $H_2(z)$ functions appearing in the power-series expansion of the field.

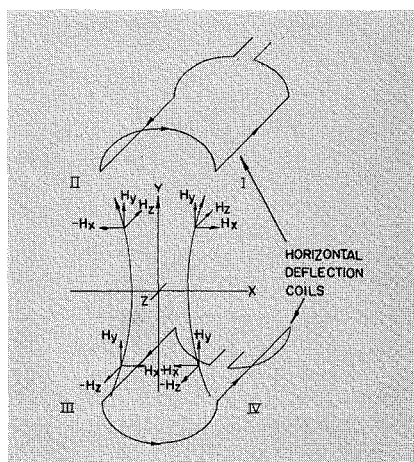

Fig. 1—Typical yoke field with horizontal coils energized.

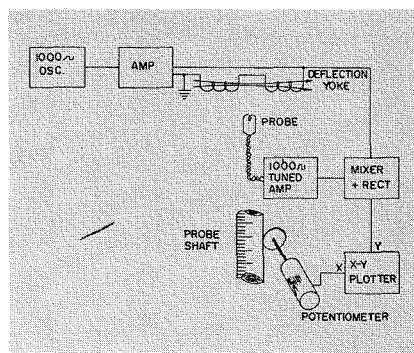

Fig. 2—Yoke field plotting equipment.

MEASUREMENTS OF THE FIELD

The field direction and strength are determined by energizing the deflection coil with a 1-kc sine-wave current and measuring the induced voltage of a search coil (Fig. 2). The advantage of this method is that any magnetostatic field in the vicinity of the field being measured will not introduce errors. The $H_1(z)$ and $H_2(z)$ functions are plotted automatically on an x - y plotter with one variable (x) driven by the probe z -axis motion. Since the field may change direction as a function of the z distance, the converter compares the phase of the search-coil voltage to that of the yoke driving current. The two phases are compared in a mixer, and the resultant output is amplified and rectified (Fig. 3). The rectified output is then fed to the second variable (y) of the x - y plotter.

Since the $H_1(z)$ and $H_2(z)$ functions represent field-intensity variations as a function of the z distance, measurements are taken along lines parallel to the z -axis. One of these lines is the z -axis itself, and the $H_1(z)$ function is obtained directly if only the H_y component is measured. This component can be measured by positioning the probe for maximum voltage at the x - y mechanical center of the deflection yoke. The mechanical center may not coincide with the magnetic center, but it is a good approximation. A method which is based upon the symmetry characteristics of the field is used for exact centering. At this

Fig. 3—Conversion of search-coil output for x - y plotter operation for a typical $H_2(z)$ function.

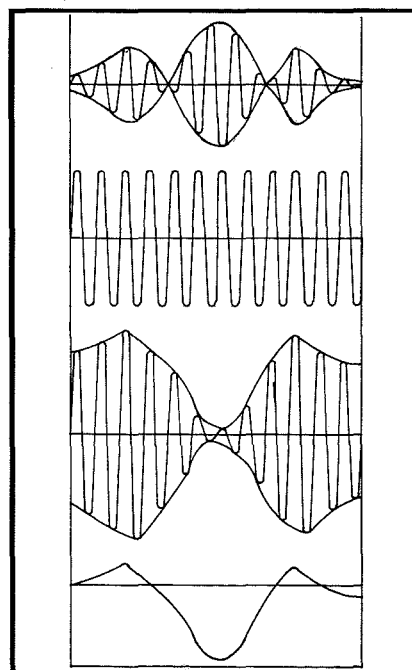

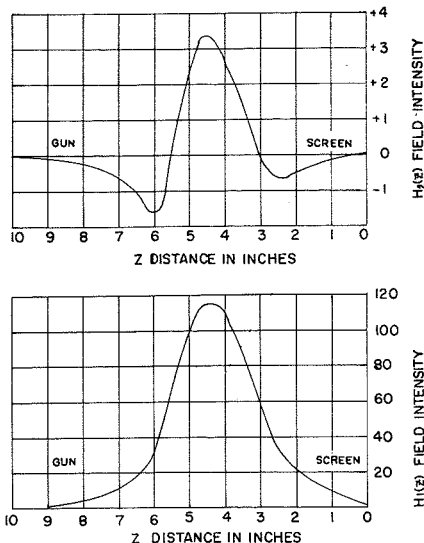

Fig. 4—Top: Main deflecting component, $H_1(z)$; bottom: nonuniformity component, $H_2(z)$.

point $x = 0$ and $y = 0$ and the field equation for the H_y component becomes $H_y = H_1(z)$.

The $H_2(z)$ function can be measured by observing that the H_x component of the field contains only the $H_2(z)$ function in the third-order approximation: $H_x = 2H_2(z)xy + \dots$

Since the $H_1(z)$ function was measured at the x - y mechanical center, the H_x component must be zero along the z -axis. Therefore, if the search coil is rotated until a null is observed, it will then be positioned to record the H_x component. The $H_2(z)$ function is then determined by moving the probe off the z -axis in the x and y directions and traversing a line parallel to the z -axis. With the x and y coordinates known, the $H_2(z)$ function becomes $H_2(z) = H_x/2xy$.

These two functions can now be substituted into the field equations, and the three field components are defined for the third-order approximation. Plots of the $H_1(z)$ and $H_2(z)$ functions are shown in Fig. 4. The $H_1(z)$ function can be considered as the main deflecting component while the $H_2(z)$ is the non-uniformity component.

PROBE CONSTRUCTION

The probe used for these measurements is fabricated from a glass rod, $\frac{3}{8}$ inch by 12 inches, that is ground true along the longitudinal axis. A search coil is mounted in a slot cut in one end of the rod (Fig. 5). Leads connecting the search coil to the amplifier are twisted and terminated at the base of the probe, since this connection could introduce an error if it were in the field. For instance, the ratio of H_y intensity to H_x intensity could be in the order of 100:1. Consequently, if the H_x component is being measured, stray pickup from the

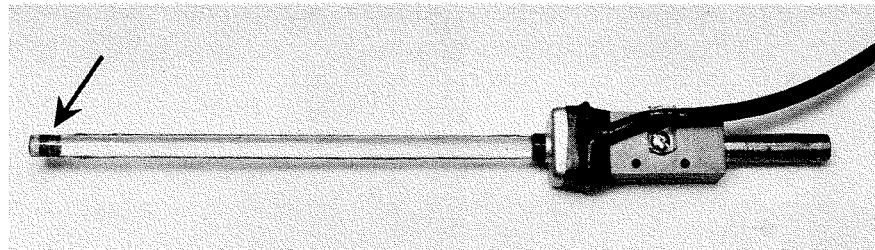

Fig. 5—Glass-rod probe, (about 1 foot long). Note search coil (arrow) and twisted leads along glass rod.

H_y component could severely affect the H_x readings.

Search-coil construction is also critical when 100:1 ratios of intensity are encountered. The finish turn of the coil should be close to the start so that a negligible additional loop is established when the leads are connected to the amplifier.

PROBE POSITIONING EQUIPMENT

The positioning equipment (Fig. 6) is essentially an indexing table that allows the probe to be located in three dimensions with an accuracy of 0.001 inch. The probe can be rotated independently to measure the H_x and H_y components. The z axis feed is motor-driven at a speed of 20 inches/minute. A multiturn potentiometer is coupled to the z feed, and a voltage drop proportional to the z distance is fed to the plotter.

APPLICATIONS

The two functions that are described can be used to calculate the deflection aberrations that occur in cathode-ray-tube display systems. Spot distortions, such as astigmatism and coma, are extremely sensitive to the $H_2(z)$ function. The size of the spot is related to the effective length of the yoke field which is affected by the $H_1(z)$ function.²

The field equations given can also be applied to a Helmholtz coil, since it has the same symmetry characteristics as a deflection yoke. The uniformity of field can be determined by measuring the $H_2(z)$ function of the Helmholtz coil.

In a deflection yoke, the $H_2(z)$ is mainly determined by the distribution of turns in the coils. Consequently, non-uniformity in the coil windings can be detected by plotting the $H_2(z)$ in each quadrant and comparing the symmetry between quadrants. Production control can be established by placing limits on the shape and symmetry of the $H_2(z)$

function. The effects of shielding and stray fields can also be evaluated by using this equipment.

SUMMARY

This technique is basically for analyzing and measuring a symmetrical type of magnetic field. The equipment may be used to measure other types of electromagnetic fields by locating another search coil perpendicular to the H_x and H_y coil. Since this coil would measure the H_z component, all three components of a field can be obtained for every x, y, z coordinate.

BIBLIOGRAPHY

1. Haantjes, J. and Lubben, G. H., *Errors of Magnetic Deflection*, Philips Res. Rep., 12, 1957; pp. 46-68.
2. Kaus, P. E., "Effect of Magnetic Deflection on Electron Beam Convergence," *RCA Review*, Vol. XVII, No. 2, June 1956; pp. 168-189.

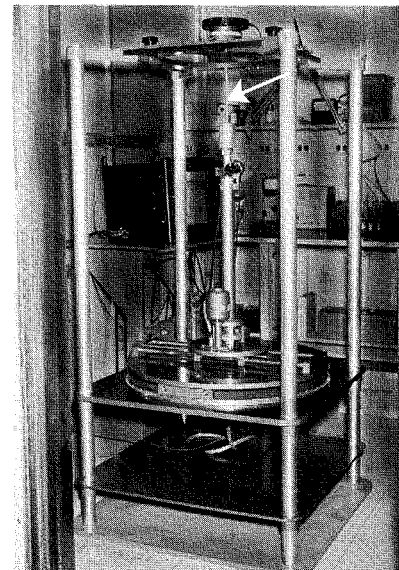
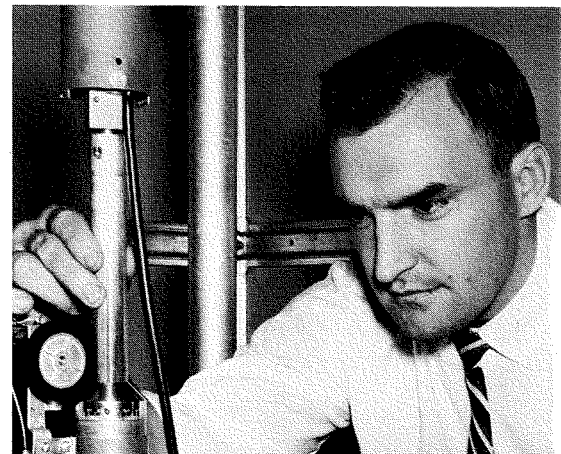
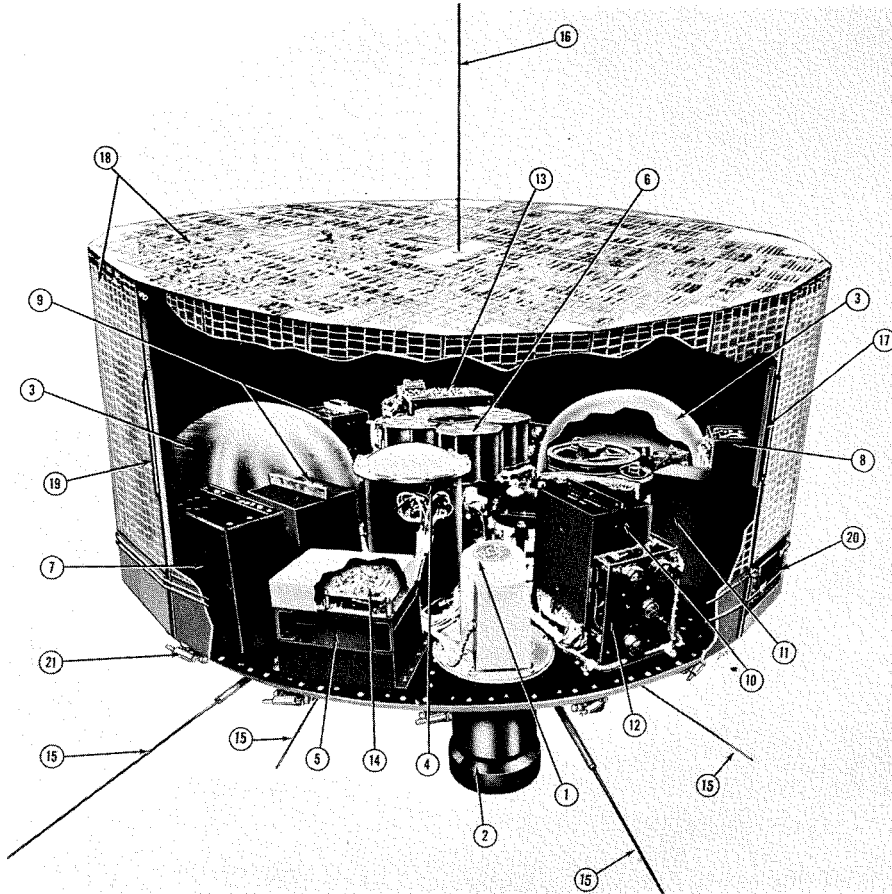

Fig. 6—Above: indexing table for positioning probe in three dimensions to 0.001-inch accuracy; arrow indicates probe in place. Below: the author, L. J. Bazin.



L. J. BAZIN received his B.S. in Physics from the Drexel Institute of Technology in 1959. He is presently obtaining credits toward an M.S. degree at the University of Pennsylvania. Mr. Bazin joined RCA in 1955 under the Drexel co-op program. He has primarily worked in applied research on television deflection systems. During the past year, he has participated in the evaluation of wide-angle deflection color television. He is a member of the American Institute of Physics.



TECHNICAL FEATURES OF THE TIROS SATELLITE SYSTEM

by G. CORRINGTON and C. C. MARTINELLI

*Astro-Electronics Division
DEP, Princeton, New Jersey*

This article summarizes the technical aspects of the TIROS I satellite and ground station, with information added to illustrate the modifications made to create TIROS II. In the article following, Messrs. Sternberg and Schnapf discuss the performance, evaluation, and meteorological significance of TIROS I.

FOR MANY YEARS, meteorologists have been limited in the prediction of the earth's weather by their inability to observe and measure associated phenomena from a great distance outside the earth's atmosphere, where large areas could be viewed at one time. As a first step toward filling this information gap, the TIROS (Television Infra-Red Observation Satellite) system was developed under the auspices of the National Aeronautics and Space Administration, under the technical direction of the U.S. Army Signal Corps, (Contract DA-36-039-SC-78902). It includes the first television-equipped meteorological satellite, and was conceived as an experiment to determine the feasibility of observing the cloud-cover and the distribution of infrared radiation of the earth by telecommunication from an earth satellite.

Shortly after the successful launch of TIROS I on April 1, 1960, AED was awarded a contract by NASA to modify test and backup models of TIROS I to

accommodate a NASA infrared experiment. In addition, improved attitude control was added, and some of the TIROS I hardware was modified to gain even better TV performance. This TIROS II satellite is described briefly in Fig. 2, while the remainder of this article describes the TIROS I satellite and ground station.

THE SATELLITE

The TIROS I satellite (Fig. 1) is an 18-sided right polyhedron, 42 inches in diameter and 22.5 inches high excluding antennas. Its total weight is approximately 265 pounds. It contains two independent TV systems as primary sensors capable of either direct r-f link operation or remote operation by magnetic-tape storage of video information. The many separate, but coordinated functions necessary to make the TIROS satellite useful may be classified broadly as: 1) television, 2) position reference, 3) telemetry, 4) control, 5) power supply, 6) dynamic control, 7) thermal control, and 8) structure.

Fig. 1—The TIROS I satellite: 1) one of the two half-inch vidicon cameras; 2) TV camera lens; 3) video tape recorder; 4) electronic clock; 5) TV transmitter; 6) power-supply batteries; 7) TV camera electronics; 8) tape-recorder electronics; 9) and 10) control circuits; 11) power converter for tape motor; 12) voltage regulator; 13) battery-charging regulator; 14) auxiliary synchronizing generator for TV; 15) transmitting antenna; 16) receiving antenna; 17) and 19) solar sensor for detecting sun angle at time of picture-taking; 18) solar cells; 20) despun yo-yo mechanism to slow spin-rate; 21) spin-up rockets to boost spin rate.

Television

An FM-FM system is used for televising information to earth from the satellite. Two identical camera chains are used, differing only optically. A wide-angle camera, with 104° wide-angle lens, provides large-area coverage, and a narrow-angle camera, with a 12.67° coverage, gives cloud detail for identification purposes. The cameras are aligned within $\pm 1^\circ$ to the spin-axis reference and have scribed marks on the vidicons for reference.

Each camera chain consists of a camera (Fig. 3a), modulator, tape recorder (Fig. 3b), and transmitter. A common antenna system is used for both chains.

The basic tube used in the camera is a ½-inch vidicon developed especially for this purpose. A 500-line picture is obtained from the vidicon with a 2-second frame rate. The video, with a bandwidth of 62.5 kc, frequency-modulates an 85-kc sub-carrier, using a modulation factor of 0.24. In direct r-f link operation, the sub-carrier is applied directly to a 235-Mc, 2-watt FM transmitter. When the satellite is in the remote mode, i.e., gathering information but not in direct communication with the ground station, the subcarrier is recorded on magnetic tape. The magnetic tape is then played back on command from a TIROS Data Acquisition Station when the satellite is within a 1500-mile radius of the ground station. Direct-link pictures may be taken by either camera at 10-second or 20-second intervals, or the cameras may be programmed alternately at 30-second intervals. During remote operation, pictures may be recorded either synchronously or separately. Thirty-two pictures are stored on each tape and are taken at 30-second intervals. Electronic clocks are used for timing and can be alarmed at any time up to a maximum of 5 hours in 2-second increments.

The tape recorders used for this application were designed specifically for satellite use. Four hundred feet of ⅜-inch mylar-base tape is used with a tape speed of 50 inches/second. Recording is done only during individual picture read-out, but playback is a con-

tinuous operation upon command from the ground station.

A balun diplexer network is used to couple the transmitter to the antenna. Four transmitters are used, two beacons and two for tv; they share a common antenna. The balun diplexer network provides the necessary coupling and isolation functions, and also divides and phases the antenna drive currents to achieve circular polarization of the antenna pattern. The transmitting antenna is a pair of crossed dipoles fed in quadrature.

Position Reference

Information on the vehicle's attitude and rotational position is necessary to properly evaluate the pictures taken. It is provided by a horizon scanner and a north-indicator system.

The horizon scanner essentially sees the difference between the temperature of outer space and the earth by means of an infrared cell. The scanner triggers a multivibrator upon intercepting and again upon leaving the earth during the satellite's rotation about its spin axis. This information is transmitted continuously to earth on the beacon transmitters.

The north-indicator system consists of nine equally-spaced solar cells mounted in wells around the periphery of the vehicle. An aperture covers each well and provides a 1° fan-shaped beam. The output of each cell triggers one of three uniquely sequenced multivibrators. When this information is referenced to a time-of-picture-exposure, a sun-angle referenced to the vehicle is known, and from this, the picture can be oriented with respect to north.

Telemetry

Two 30-mw beacon transmitters (Fig. 3c) operate continuously on 108.00 Mc and 108.03 Mc. These provide tracking information to the ground stations and are also used for relaying telemetry. Telemetry provides information on temperatures and operating conditions within the satellite. Two forty-positions switches, one for each beacon, automatically sequence in about 35 seconds whenever the ground station activates the satellite. The two switches are wired in parallel for redundancy.

Controls

Functional control is provided for the satellite by using a series of bandpass filters in the audio range. Eight separate tones are used, and different combinations of them allow for different functions. Provisions are made to allow for the tube filament warm-up time, and

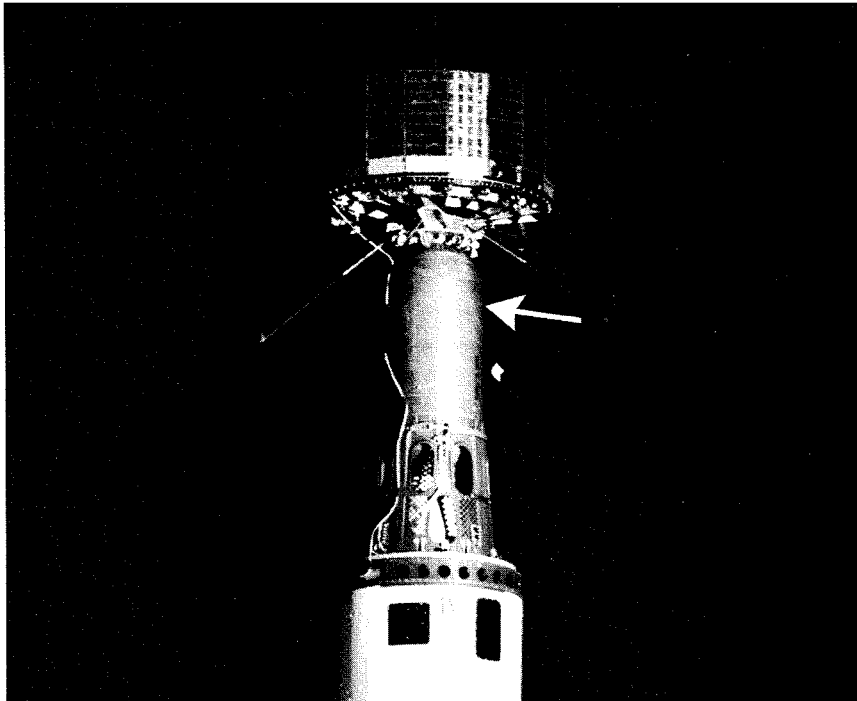

Fig. 2a—The TIROS II satellite during pre-launch checkout at Cape Canaveral, Fla. TIROS II was successfully orbited on Nov. 23, 1960. As of Feb. 13, 1960, TIROS II had completed 82 days of operation. In its first 1200 orbits, it returned over 20,000 TV pictures. TIROS II is shown mated to the ABL-248 solid-fuel third-stage rocket (arrow). The second stage of the Thor-Delta launch vehicle is just below. A protective shroud (not as yet installed in the picture) covered the satellite and third-stage rocket during the initial flight, and was jettisoned prior to separation of the third stage and satellite from the second stage.

TIROS II Adds Improved Attitude Control and IR System

Electromagnetic Attitude Control. As a result of the observations made on TIROS I spin-axis motion and analysis and tests in a magnetic test fixture (Fig. 2b) one of the major additions to TIROS II was the inclusion of an attitude-control device that would control the satellite's spin-axis orientation to obtain optimum performance from the infrared subsystem, cameras, and power supply.

The attitude control is achieved by developing within the satellite (by electromagnetic means) a torque, or torques, which can be related to the noncontrolled torque in a way to alter the spin-axis motion in the direction desired. This is accomplished by programming (from the ground) various steady currents in a coil wrapped around the periphery of the TIROS II satellite. The magnetic dipole, equivalent to a small bar magnet in the satellite, interacts with the earth's magnetic field as the satellite orbits, the net result being a torque acting on the spinning body. This torque precesses the spin axis of the satellite.

Infrared Equipment. The NASA infrared experiment incorporated in TIROS II (Fig. 2a) consists basically of two radiometers, a tape recorder, and a transmitter. One "scanning" radiometer measures five spectral ranges. These sensors view a narrow field down through the base of the satellite at a 45° angle to the spin axis. A reference level is obtained by having them alternately look up at 45° into space. The scanning ranges (microns) are:

- 5.9 - 7.0 (Radiation from earth's troposphere)
- 0.6 - 0.8 (Visible spectrum for reference)
- 0.2 - 5.0 (Earth's albedo)
- 7.5 - 30 (Earth's total emission)
- 8.0 - 12.0 (Surface or cloud emission)

The second radiometer is a nonscanning infrared detector that looks over a wide field through the satellite base parallel to the spin

axis. Its two detectors cover the following ranges: black cone, 0.2-50 microns (Earth's total reflective and thermal radiation); white cone, 5-30 microns (earth's thermal radiation).

The measured energy data is stored on the infrared tape recorder and a composite signal is played back to the TIROS II ground station complex at a 16-to-1 accelerated rate. Since the infrared sensors scan continuously, only the last 100 minutes of observation is played back.

Ground Station. Besides a major effort to incorporate the above changes and additions and still maintain a payload under 280 lbs., considerable rework to accommodate the new experiment and to give improved reception of former data was done on the ground station equipment. The TIROS I Kaena Point Station was returned to RCA for retrofit and was relocated at San Nicolas Island on the Pacific Missile Range. The stations at Ft. Monmouth, N. J. and the backup station at AED in Princeton are part of the TIROS II ground complex.



Fig. 2b—Magnetic test fixture for TIROS II.

maximum usage of ground-station contact time. All system switching is initiated within this function. Control is provided for direct use of either camera, playback of either tape recorder, and setting and starting both clocks. At the end of the useful life of the satellite, an additional control is provided to turn off the beacon transmitters.

Power Supply

Primary power for the satellite is derived from 9120 solar cells mounted in module groups on the sides and top of the vehicle (Fig. 1).

Output from these cells is used to charge storage batteries during periods of inactivity of the satellite. Voltage and current regulators are used to provide regulated voltages to the systems and to limit charging current to the batteries. A bypass voltage regulator allows power not required for battery charging to be used for system operation directly. Diode decoupling is used throughout the power supply to prevent undue loading during darkness.

The basic solar cell is a 1-by-2-cm unit covered with coated optical glass and having a minimum conversion efficiency of 7 percent. The glass cover provides both filtering of unwanted wavelengths and an increase in radiation efficiency. The cells are wired in a series-parallel combination for maximum reliability.

Sixty-three nickel-cadmium hermetically sealed storage batteries form a battery pack for secondary power during periods of low illumination of the solar cells. Three strings of 21 cells each provide a raw voltage to the system of 26 to 33 volts. Separate fusing and diode decoupling protect the batteries from overloading by short circuits or other failures. The total capacity of the battery pack is about 300 watt-hours under normal conditions.

Dynamic Control

Some dynamic control of the satellite can be exercised by using precession dampers, a spin-reduction device, and the spin-up rockets. These devices tend to effect and maintain a stable spin axis with a rotational velocity about the axis between 9 and 12 rpm.

At the time of separation from the third stage, any wobble due to precession or nutation is damped out by a tuned energy absorbing mass that opposes forces tending to oscillate the satellite body. Two similar mechanisms are installed 180° apart on the vehicle's sidewalls. Weights that are restricted during launch are released at separation and roll freely along bowed rods. The device is tuned to the precession

frequency of the satellite and rapidly absorbs the energy causing the wobble.

To provide stability during launch, the satellite is spun at 120 rpm. This spin rate is maintained until after the precession damping is completed. For attitude information and picture-taking purposes, a rotational rate of 9 to 12 rpm is necessary. The difference in energy is dissipated by releasing two diametrically opposed weights on long cables. When the cables become radial to the vehicle, the weights and cables are released from the vehicle and the satellite is despun from 120 to 12 rpm within 1/2 second.

The earth's magnetic field acting upon magnetic materials in the satellite reduces the spin rate of the vehicle to below the desired 9 rpm after being in orbit for a time. On command from the ground station, a diametrically opposed pair of small spin-up rockets attached to the periphery of the vehicle (Fig. 3d)

peak at a wavelength of about 10 microns. For areas where high reflectivity is desirable, the thermal finish has an emissivity of about 0.15 at 10 microns. Conduction from cover to baseplate also stabilizes temperatures.

Structure

The satellite structure is essentially a right cylinder with the vertical skin consisting of 18 panels attached to a skeleton framework connecting the top and baseplate. Substantially all of the payload components are mounted to the radial ribs under the baseplate (Fig. 3d). These ribs are contoured in accordance with the average load and moment forces generated along them. The baseplate gives peripheral support to the integrated top- and side-panel assembly. The total loads are passed to the center of the baseplate, to the hub, and then to the carrier rocket through the mating ring.

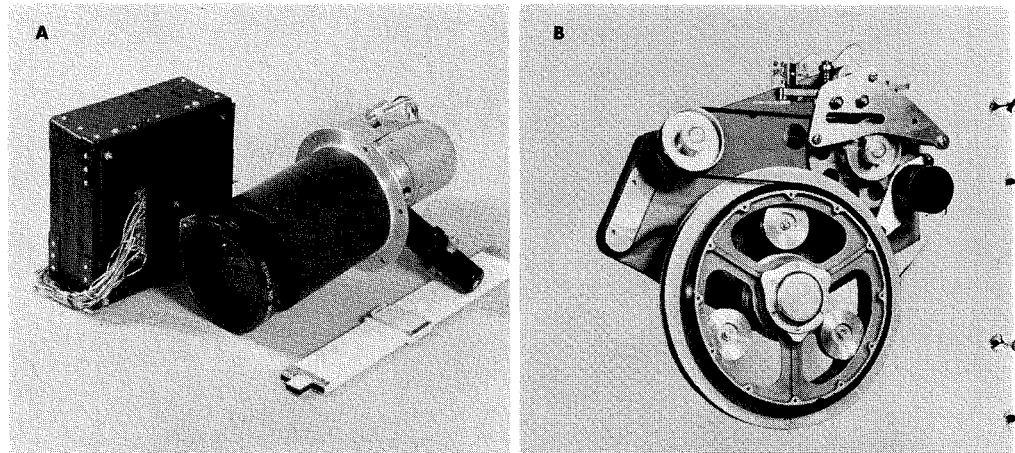

Fig. 3—Some key components of TIROS I and II; A) TV camera; B) tape recorder; C) beacon transmitter; D) satellite baseplate, showing spin-up rockets.

are selected and fired. The solid propellant rockets each have an impulse of 1.4 pound-seconds and return the spin rate to 12 rpm.

Thermal Control

A passive thermal-control system is used to maintain vehicle temperatures between 0°C and 50°C. Orbital conditions are such that the top and walls of the vehicle, which have a low ratio of mass to area, face the sun, and the baseplate, with all the components mounted on it, has little incident heating. To avoid high thermal stresses, the thermal-radiation characteristics were enhanced by the use of proper finishes. Maximum radiant-energy interchange within the satellite is assured by using finishes with emissivity values of approximately 0.9 at temperatures which

The structure is designed for high strength to withstand the rigorous ascent loads and environmental factors, with sufficient rigidity to provide a suitable mounting surface for the brittle solar cells, and with sufficient strength to maintain the required tolerances for optical mountings. Load levels of 50 g in the axial direction and 30 g in the radial direction may be applied to the vehicle without damage. The structure, with its payload, is statically and dynamically balanced to eliminate disturbances during launch and to ensure rotation about an axis parallel to the optical axis while it is in orbit.

THE GROUND STATION COMPLEX

The command and data-acquisition complex for TIROS I (designed, built, and installed by RCA) comprises two primary ground stations and one back-up ground station. One of the primary stations is located in the Evans Signal Laboratory area of the USA Signal

Research and Development Laboratories, at Ft. Monmouth, N.J. with operational responsibility assigned to their Astro-Electronics Division. The other is located at the Lockheed Missile and Space Division at Kaena Point in the Hawaiian Islands. Lockheed has operational responsibility for this station with the assistance of RCA personnel. The back-up station is located at the RCA Astro-Electronics Division of Princeton, and is an experimental or prototype station developed by the AED Data Handling and Ground Systems Group.

Antenna Systems

At Kaena Point, a 60-foot dish, already at the site, was modified to have both 235-Mc and 108-Mc separate horizontal and vertical feeds. An auto-track capability by means of a conical scan system was provided at 235-Mc. The command transmitting antenna is mounted on a modified SCR 584 radar dish located

tion at the command transmitter frequency, having a 35° beam width and a gain of 10 db.

- 2) Four elements are used at 108-Mc with horizontal polarization. The horizontal or azimuth pair are fed into a hybrid ring to produce a sum and difference output in azimuth. Similarly, the vertical or elevation pair are also connected to a hybrid ring to produce a sum and difference output in elevation. The hybrid rings then provide the necessary sum or reference signal, an elevation error signal and an azimuth error signal to produce the basic inputs for a phase-monopulse tracking system. An 18° beamwidth and a gain of 18 db is achieved at 108-Mc.
- 3) Eight elements are used with all horizontal dipoles in parallel and all vertical dipoles also in parallel to produce separate horizontal and

three alarm times are: 1) time at which a direct picture sequence (pictures in real time) is called for, 2) time at which playback of pictures stored on tape is called for and 3) time at which a pulse is sent to the payload to start the clock for remote picture taking.

Command Program Unit

The command programmer unit is divided into three basic control functions:

- 1) Direct (real time) Camera Sequence I with choice of Camera Chain I or II, picture-taking interval of 10 or 30 seconds and total time of picture taking up to 8 minutes. This sequence is initiated by Alarm 1.
- 2) Playback sequence with choice of either or both tape recorders sequentially. Normally, during the playback sequence, the payload clock-setting pulses are sent out at this time. Another function available during this sequence is the choice of when to fire the spin-up rockets. The start of the playback sequence and its various functions is controlled by Alarm 2.
- 3) Direct Camera Sequence II with the same choices as Direct Camera Sequence I. This sequence, if selected, automatically follows the playback sequence. The command program is also arranged to be started or programmed manually. In the former case this means that the initiation of alarm times can be done manually. In the latter case complete manual operation is made possible by depressing buttons for the desired program and for the desired length of time.

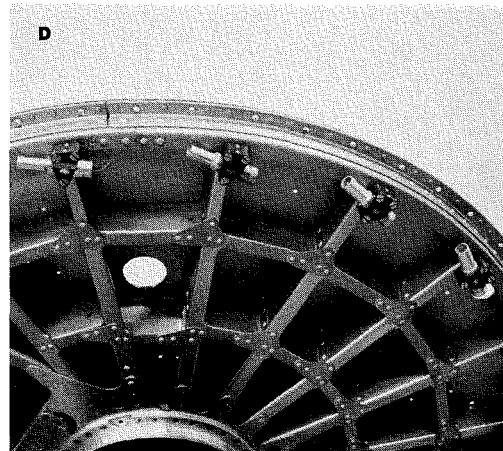
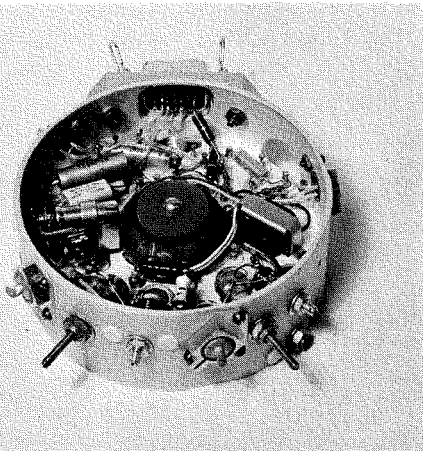

about two miles from the equipment vans and slaved to the 60-foot dish. The command transmitters are unattended and remotely operated from the vans.

The Fort Monmouth station uses a similar 60-foot dish, except that in this case the command transmitter antenna is a crossed yagi mounted on the periphery of the dish. Because the TIROS system transmits while it receives, suitable bandpass filters were installed in the 235-Mc and 108-Mc receiving system to reduce cross-talk to a negligible level. Antenna gains at 235-Mc and 108-Mc are 29 and 23 db, respectively.

The experimental station at Princeton, N.J. uses the SVE (swept volume efficiency) antenna built for AED by General Bronze Company. This type of antenna uses an array of dipole-driven, slow-wave elements. It consists of three separate antenna systems as follows:

- 1) A single central element capable of being connected to provide either linear or circular polariza-

vertical outputs at 235-Mc. A 10° beamwidth and 22 db gain is obtained with this configuration.

Coaxial and multiconductor cables carry video subcarrier, telemetry signal synchro data, and hot-line communications to the AED Ground Station, which is located approximately 2000 ft. from the antenna site.

Master Timing System

The command system consists of a series or combination of tones which amplitude-modulate the command transmitter. Exact time of transmission and duration of tones is controlled by a master timing unit, which consists of a frequency standard driving a mechanical clock. The clock generates a basic, 10-second timing interval. Three series of stepping switches in combination with manually set dials permit the preselection of three alarm times in 10-second intervals over a 24-hour period for either command program A or B. These

Clock-Set Unit

The clock-set unit is automatically energized during the playback sequence. It is a counter which gates through a pre-set number of pulses from 1 to 8999. Each pulse less than 9000 sent to the clock represents a delay of time of 2 seconds after the clock start pulse has been transmitted. Nixie tubes indicate the number of pulses sent, and Alarm 3 from the master timing unit indicates the exact time of clock start.

Antenna Programmer

The antenna programmer is a function generator which accepts 16 manual inputs in azimuth and elevation as a function of time. When the payload orbit has been established, the ephemeris data received at each ground station is converted on a time basis to elevation and azimuth angles. This information is set into the antenna programmer.



GLENN H. CORRINGTON received his B.E.E. degree from the University of Minnesota in 1953. From 1953 until 1958 he was with RCA Defense Electronics Products Division in Camden, New Jersey. Upon completion of the engineering training program, he was assigned to the Airborne Fire Control section where he did research and development on automatic frequency controls and i-f amplifiers for radar until 1955. From 1955 until 1958, he was senior systems engineer responsible for integration and evaluation of the AERO-11B and ASTRA-CF105 fire control, communications, and navigation systems. At the Astro-Electronics Division, which he joined in 1958, he has been senior systems engineer responsible for integration, evaluation, and tests of the TIROS I and II satellites. He was also the RCA senior payload engineer at Cape Canaveral for the TIROS I and II launches.



C. C. MARTINELLI received his B.S. degree in Electrical Engineering from Massachusetts Institute of Technology in 1930. Immediately following, he joined the RCA Manufacturing Company in Camden, where his major work was in television receiver development. In 1942, Mr. Martinelli transferred to the then-new RCA Laboratories in Princeton. At the Labs, he was engaged in research on various aircraft navigation and radar systems, and had systems responsibility for the air-to-surface fire-control system "Killer." Mr. Martinelli joined the Astro-Electronics Division upon its formation, and is currently Project Engineer for the TIROS I and TIROS II Ground Equipment. He is a member of Sigma Xi and the Institute of Radio Engineers, and holds 10 patents.

and sun pulses are also recorded on two tape recorders for data storage.

Attitude Recorder

The pulses occurring at the times when the satellite horizon scanner sees the earth and leaves the earth are demodulated and are used to drive an elapsed-time computer. The output of this computer is punched tape, containing a series of time intervals in teletype code which is the time the scanner sees the earth and the time it sees the sky. The ratio of the smaller time interval to the total time interval of one rotation of the satellite is the fraction of 360° that the sensor sees the earth. Knowledge of this angle, together with the height of the satellite above the earth, permits calculation of the angle between the spin axis and the local vertical.

Telemetry System

Both telemetry information and attitude information are derived from the 108-Mc and 108.03-Mc beacons. Two receivers operating in diversity combination are used for each beacon frequency. The outputs of the receivers are subcarrier tones which are deviated by the various sensors in the satellite. The subcarriers are demodulated in a Sanborn frequency meter pre-amplifier and used to drive Sanborn recorder pens.

Calibration System

An important part of the ground station equipment is a video pattern generator and subcarrier oscillator system for over-all system checks. The unit also provides simulated sun pulses, which together with subcarrier pulses, permit rapid checks on the performance of the north indicator. The subcarrier is modulated with a video pattern consisting of a 16-step-density wedge signal and an accurate bar generator. Black and white levels can be accurately checked, as well as the density range between them. The bar generator permits accurate adjustment of monitor aspect ratio and checks on sweep linearity. The importance of an accurate calibration procedure to check linearity and density cannot be underestimated, because meteorologists are interested in locating storm centers as accurately as the system will permit.

CONCLUSION

The TIROS satellite system utilizes techniques and devices highly sophisticated in the present satellite state of the art. The equipment and techniques for evaluation of the wealth of data obtained involve efforts in addition to those described herein for the satellite and ground-station complex itself.

Events Recorder

A 20-channel pen recorder displays all command functions sent out to the satellite. It also displays tv and beacon receiver agc voltages above a selected minimum value. The events recorder provides a prepass check on the functioning of the command programmer, as well as a permanent record of the commands transmitted.

TV System

In the TV system (FM-FM), a subcarrier in the satellite is deviated by a video and synchronizing signal generated in the camera systems. This subcarrier and the nine sun cells spaced 40° apart around the payload frequency modulate the tv transmitter. On the ground, the subcarrier and sun pulses are the outputs of a pair of FM receivers connected in polarization diversity. Since the modulation characteristic of the tv transmitter system is quite linear, the separation of video subcarrier from 10-kc sun pulses is easily accomplished by bandpass filters.

The video subcarrier is nominally 85-kc and is deviated ± 15 -kc. The blacker-than-black level is set at 100-kc, and white at 70-kc. The 500-line, 2-second-scan tv system requires a 62.5-kc video bandwidth. The lower sidebands of the subcarrier can extend down well into the 62.5-kc video band. In the demodulator, the subcarrier is applied to symmetrical clippers which drive a delay line to produce pulses of uniform width and varying frequency. These pulses are doubled to produce a center frequency of 170-kc and a deviation of 30-kc. The lower sidebands extend down to about 80-kc and a

d-c-coupled low-pass filter separates the 62.5-kc video from the subcarrier components. The output of the filter is applied to chopper-stabilized d-c amplifiers and then to the grid of the monitor kinescope. The system has the virtue of a tv system in which the d-c component is transmitted and maintained to the kinescope grid. Vertical synchronizing pulses are generated by the leading edge of the demodulated subcarrier. The developed 2-second subcarrier pulse actuates a relay that opens the camera shutter and holds it open for the 2-second scan period. An afc system is used in the horizontal sync system.

Miller integrator sweep circuits are used for generating horizontal and vertical sweep voltages. The starting and run down of the sweep voltages are controlled by reference diodes which assure stable limits to the sweep. The retrace slope, run-down slope, and sweep limits are separately adjustable. The sweep voltages drive transistorized push-pull deflection amplifiers with a built-in, self-balancing feature.

North Indicator

This equipment, also called the *sun angle computer*, presents a display in binary coded lights that indicates the angle between a reference line in the satellite and the sun, at the instant a picture is taken. Knowledge of this angle and the position of the satellite in its orbit provides sufficient information to determine where north is on the resulting pictures. The indication of sun angle, frame number and program called for are photographed with the tv picture. The video, subcarrier, frame number,

PERFORMANCE OF TIROS I

S. STERNBERG, Chief Engineer

*Astro-Electronics Division
DEP, Princeton, New Jersey*

and

A. SCHNAPF, Mgr.,

*Tiros Project
Astro-Electronics Division*

THE SUCCESSFUL LAUNCH of the TIROS I meteorological satellite on April 1, 1960 was the culmination of many months of system development, design, and fabrication, and arduous environmental simulation and test. The rapid accumulation of data from TIROS I outweighed all anticipation, and thousands of cloud pictures literally swamped the using agencies. However, it took only a short time before the basic objective—to prove the feasibility of short-term satellite weather-forecasting—was achieved. And, within a matter of minutes after launch, the hardware design concepts had been proven.

SATELLITE LAUNCHING

The TIROS I satellite was launched into an almost circular direct orbit at an altitude of 400 nautical miles, at an inclination of 48.3 degrees. The orbit eccentricity has been calculated as 0.004214.

The satellite was spin-stabilized, with the spin-axis vector fixed in space. Thus, as it orbited around the earth, the cameras faced both towards and away from the earth at different points

SIDNEY STERNBERG received his B.S. in Physics from the City College of New York in 1943 and his M.S.E.E. from New York University in 1949. During World War II, he served as a radar officer in the U. S. Navy. From 1946 to 1950, he was affiliated with the Office of Naval Research, where he made significant contributions to computer research. He joined the RCA Laboratories in 1951, where he initially engaged in research programs typified by the Typhoon computer and Dynamic Systems Synthesizer. He was honored for his accomplishments with the RCA Laboratories *Research Achievement Award* in both 1953 and 1955. In 1955, when a previous study of television for space reconnaissance was broadened into a research study for an over-all space-reconnaissance system, he was placed in charge of the information systems portion of the program. He subsequently was Project Manager of a feasibility study leading to a design project for a TV reconnaissance satellite system. He moved to the Astro-Electronics Division upon its formation in 1958 as Manager of Satellite Projects, and was soon after named Chief Engineer of the Division. Two notable developments under his technical management were the "Talking Atlas" satellite (Project SCORE) and TIROS. Mr. Sternberg holds several patents, is a Member of the American Rocket Society and Sigma Xi, and a Senior Member of the IRE.

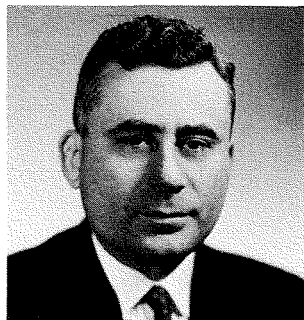

in the orbit. The time of launch was selected so that the sun was behind the satellite (within 60° of the optical axis), illuminating the earth while the cameras were facing it. Because of rotation of the earth around the sun, this favorable relationship existed for only about four months (out of twelve). During these four months, the cameras were expected to encounter cycles of good, poor, and no illumination, because of orbital precession. However, all portions of the global belt—scanned from 50° north to 50° south latitude—were covered many times during the scheduled three-months of active operation for the system, so that favorable illumination of all points over a succession of orbits was assured.

A successful separation from the ABL 248 solid-fuel rocket was achieved after a 20-minute coast to overcome any residual burning in the third stage. Following separation, the satellite precession dampers performed exceptionally well by removing any spin-axis wobble, and keeping the spin axis with $\pm 1/2^\circ$. Seven minutes after third-stage and payload separation, the

A. SCHNAPF received his B.S.M.E. from the City College of New York in 1948 and his M.S.M.E. from Drexel Institute of Technology in 1953. Mr. Schnapf worked for the Goodyear Aircraft Corporation from 1948 to 1950 as a development engineer on jettisonable fuel tanks, blimp car structure design, pilot's cockpit enclosures, and radomes. He joined RCA in 1950 and was a Manager responsible for aerodynamic, thermal, structural analysis, wind tunnel, and flight testing of the MOD II Shoran bomb system. He participated in the design, development, and aircraft integration of an electronics weapon system for a Mach 2 interceptor. He was also responsible for the design, development, and environmental and operational evaluation of the Astra Fire Control subsystem. He has participated in studies of the AICBM Boost Track System and the ECM Satellite Study. At the Astro-Electronics Division, Mr. Schnapf is Manager of Electro-Mechanical Design in the Space Vehicles Group. He has participated in the design, development, evaluation, and environmental simulation of the TIROS I weather satellite system, and was responsible on this program for AED's launch operations at Cape Canaveral. He is Project Manager of the TIROS II and TIROS III weather satellite projects. Mr. Schnapf is a Professional Engineer in the state of New Jersey and is a member of the American Rocket Society.

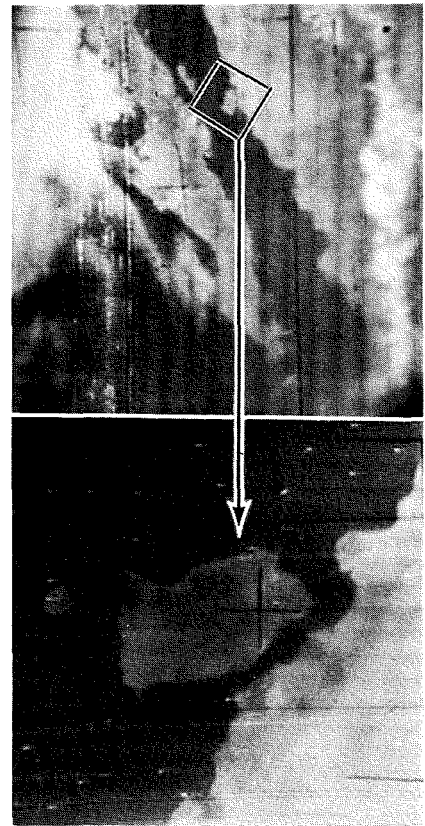

Fig. 1—Top: wide-angle TV picture of the lower California peninsula and Gulf of California. Bottom: photo from the narrow-angle TV camera of the islands of Tiburon and San Esteban in the Gulf of California.

TIROS yo-yo weights were successfully released to despin the payload in 1/2 second from third-stage injection rotation of 84 rpm to a spin rate of 10 rpm.

During the first orbital pass, 99 minutes after launch, the first cloud cover photos were transmitted to the TIROS ground stations at Ft. Monmouth and the Astro-Electronics Division's plant just east of Princeton. Orbit after orbit, day after day, pictures and performance data were transmitted to the Kaena Point, Hawaii, Fort Monmouth, and AED ground stations. By the end of June, over 23,000 pictures and many rolls of telemetry data indicating the performance of the many subsystems had been received for study.

Seven weeks after launch, a pair of spin-up rockets were fired to increase the payload spin rate from 9.4 to 12.85 rpm. Five months after launch, the second pair of spin-up rockets were fired successfully to increase the satellite's spin rate from 11.7 to 13.5 rpm.

SATELLITE PERFORMANCE

From the very first picture acquired on April 1 (Orbit No. 1) TIROS I demonstrated the capability of TV picture-taking techniques that can be utilized as a means of presenting a very large amount of weather data over a large part of the earth in a very short time—particularly the observation of weather systems that are not observed readily by conventional weather stations.

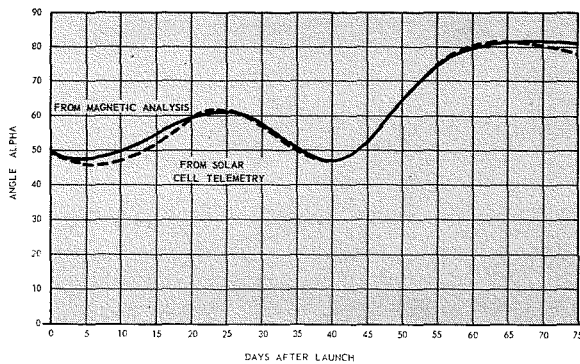

Fig. 2—Angle α vs. days after launch.

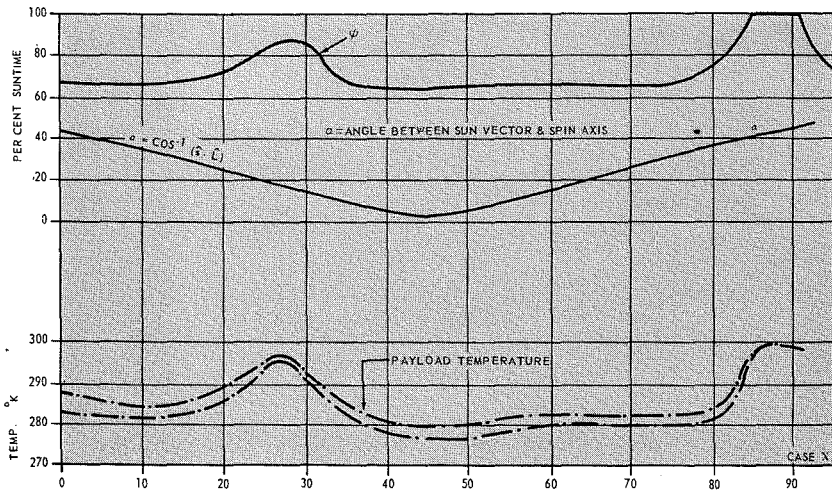

Fig. 3—Predicted satellite temperatures for an unperturbed orbit vs. days after launch. (Ψ = percent sun time.)

TV Cameras

The quality of the TV pictures was excellent (Fig. 1). These cameras were optimized for photographing cloud-cover, rather than land areas (e.g., the dynamic range, spectral response, filters). Change in electrical or optical focus was not noticed on any of the pictures evaluated. During the first several hundred orbits, the total aspect ratio remained completely within the design specifications. A comparison of the results and the earlier estimates of the TV signal levels shows good correlation between measured TIROS I radiation patterns and the received signal levels.

Telemetry

The TIROS I telemetry subsystem was designed to be simple and reliable, and to give an overall accuracy of ± 5 percent of full scale on each side of the center of the recorder chart. Transmission of a series of telemetered data was triggered automatically each time the satellite was interrogated. The 39 telemetered parameters were transmitted (and recorded) in about 30 seconds. As each telemetry cycle was recorded, a transparent "standard" overlay chart was laid over the recorder strip chart to determine any extreme or unusual

deviations. These quantitative values, plus information on any unusual operating conditions, were teletyped to the NASA Technical Control Center.

The TIROS I telemetry system gave an accuracy of about ± 5 percent for most data. In general, the communications system performed very well.

Electrical Power Subsystem

Prior to the TIROS I launching, the energy available to the instrumentation was calculated for each day of the initial three months of satellite life. The equations employed to perform these calculations required use of the time variation of the angle α (angle between the sun vector and the satellite spin axis) and the solar-cell temperatures throughout the period of interest. These quantities had been calculated for a specific launch time of April 1, and were based upon the spin axis remaining fixed in inertial space upon achieving orbit.

The one-hour delay in launch time invalidated these calculations. Furthermore, revised calculations could not be initiated because of the lack of accurate attitude data. A permissible programming based on power was determined from basis of early telemetered solar-cell

temperatures and estimates of α . It restricted the total load requirements to the range of 23,000 to 30,000 watt-minutes per day or 16.0 to 20.8 average watts.

About two months after launch, calculations were carried out which derived the α variation with time, based on the interaction of the earth's magnetic field and the magnetic dipole characterizing the TIROS I satellite. The α derived from solar-cell telemetry compares closely with these calculations.

Because there was a lack of data concerning variations of α , the solar-cell telemetered voltage and temperature were employed to determine α . Thus, α was not used as a means to find a result, but was calculated from the telemetered data. Fig. 2 is a plot of α for the first 75 days after launch—the greater part of the operational life of TIROS I. The α values shown are average values of 6 to 16 telemetered data points each day. Throughout the 75-day period, the α variation calculated from solar-cell telemetry differed by no more than 3° to 5° from that predicted by the magnetic-dipole analysis.

In general, the total battery voltages have remained in a region of 26 to 31 volts, the design range. A maximum measurement error of 1.3 volts can occur, but this is masked by the tolerance in battery voltage.

The Horizon Scanner

The attitude-indicator subsystem of the TIROS I satellite was built around an infrared horizon-scanner unit, and delivered a pair of spaced pulses indicating the duration of the scan from horizon to horizon of the earth. Some of the characteristics of this subsystem proved to be unsuitable for its intended operation, and it has not been possible to use its returned data for satellite attitude measurements.

Thermal Design

The approach to the temperature-control problem for TIROS I comprised three main areas: 1) analysis of the heat-flow problem, 2) development of suitable surfaces and surface coatings for application to the satellite, and 3) experimental verification of the thermal design.

The constraints on the thermal design showed that the only significant parameters available for thermal control were 1) the surface radiative properties, 2) the hour of launch, and 3) the degree of thermal communication among the mass elements of the satellite.

The temperature-time distributions for TIROS I in orbit as obtained from the telemetry data has indicated excellent agreement with the predicted thermal responses of the eight temperature sensors (thermistors), four of which are located on the baseplate and two each on the interior surfaces of the top and side skins. Compensation for the known temperature gradient between the baseplate and the average component temperature was required to obtain an exact fit between the telemetered data and the temperature prediction curves, since they refer to different thermal elements.

It was noted with some consternation in the first few days after launch that the top and side temperatures were not following the predicted temperature history (Fig. 3). This prediction was based on the evolution of α for the case of an unperturbed spin axis. A plot of the variation of an α with time using the top and side temperatures from TIROS I telemetry, and the curve of Fig. 3, indicated that the spin axis was far from remaining stationary in inertial space.

This situation soon was confirmed from the reduction of the pictorial data obtained from TIROS I. This analysis indicated a precessing spin axis whose resultant angle with the solar flux vector is in excellent agreement with that obtained from pictorial data reduction for the entire life of TIROS I to date. It thus afforded a basis for predicting the wanderings of the spin axis for the remaining life of TIROS I. Fig. 4 shows the calculated time-history of the component temperature, based on the actual spin-axis orientation, and the telemetered baseplate temperature as received from TIROS I in orbit. Since only average values of the telemetered temperatures need be employed in this comparison, the random errors in the telemetry system and read-out are necessarily removed by the averaging process. On the date of launch, the two curves differ by 1°C, whereas the component-to-baseplate temperature gradient does not reach its maximum (12°C) until the tenth day after launch.

The influence of initial temperature and thermal inertia would reasonably explain the lack of a temperature gradient on the date of launch. The reduction of the component-to-baseplate gradient during the 25th to 28th day is also understandable in terms of both the large α and ψ that existed at this time (where ψ is the fraction of the total orbit time that the satellite is illuminated by the sun). From the thermal test it was ascertained that a 9°C gradient existed between component and

baseplate temperature for the $\alpha =$ zero, $\psi = 1.0$ conditions.

PERFORMANCE EVALUATION

The performance of the major satellite functional equipments, in general, has been excellent. For one period of about 10 hours coincident with a temperature peak, excessive noise in the horizon scanner system caused it to be inoperative. Other than that, variations in performance have either been negligible or were previously accounted for by temperature calibrations. No indication of bearing wear or interference by material deposition has been noticeable in the electromechanical components.

Electronic Clock Malfunction

The first significant satellite malfunction observed was in the electronic clock controlling the remote operation of the narrow-angle camera. This component stopped operating after 22 orbits, but started functioning again during the second month (during orbit 573) of the satellite's life and continued to be operative through the third month in orbit. The evaluation group at AED is still reviewing the nature of the failure and recovery sequences, hoping to find some definite clue to this occurrence. The difficulty in analyzing what happened emphasizes the problem of analysis of the satellite's remote performance.

Satellite Attitude

The performance anomaly relating to the satellite's attitude was both a major annoyance and a potential dividend. The attitude of the satellite changed in a fashion much different and to a greater extent than was anticipated. Great care had been taken to ensure that all sources of external torques had

been considered before approving a satellite design with no attitude-correction system. Five major external torques that could affect the satellite were known: 1) differential gravity, 2) magnetic-field interaction with eddy current moments, 3) magnetic-field interaction with ferromagnetic materials, 4) drag due to air and/or microscopic dust, and 5) solar-radiation pressure. The first two and the last could be handled passively in the satellite design with the knowledge available. The magnetic-materials problem is more difficult because of the nonlinearity of the system, and the air-dust drag problem is almost impossible to combat because of the lack of information about the distribution at the altitudes in question.

The analysis of this problem was hampered by two other factors in component design. One is that the spectral response of the infrared horizon scanner was not optimum, so that the data transmitted was extremely noisy and the computer program written beforehand was unable to produce consistent determinations of the axis orientation. The second factor is that the lens of the wide-angle camera was chosen primarily to meet a 104° coverage-angle requirement, and certain of its distortion characteristics made attitude determination by photo-interpretation cumbersome and not too precise. Methods were later developed for optimum use of both the horizon scanner data and the pictures in making rapid and reasonably good attitude determinations on a day-to-day basis.

Spin-Axis Determination

However, using the information available at the time, a study and analysis of the spin-axis motion along the following lines led to the discovery of the major cause of attitude deviation.

The time of injection and the trajectory of the launch vehicle determined that the coordinates of the satellite spin vector on the celestial sphere should have been declination +19.8°, and right ascension (ra) +58.6° (Fig. 5).

After several days of picture taking, it became apparent from analyses of photographs showing the horizon or identifiable landmarks that the direction of the spin vector (and, hence, the camera axes) was not fixed, but was moving southward by as much as 3° to 5° per day (Fig. 5). On April 23, an analysis of photographs indicated that the spin axis had reached its southernmost declination, -30°. At this time, its ra had increased to +69.0°. Several days later it was determined from photographs that the spin vector was moving northward again and its ra

Fig. 4—Calculated satellite temperatures (from actual spin-axis orientation) and measured satellite temperatures vs. days after launch.

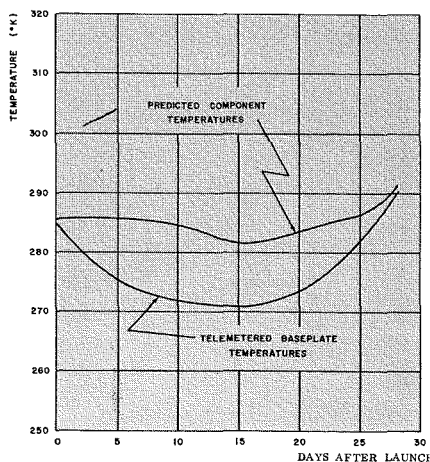

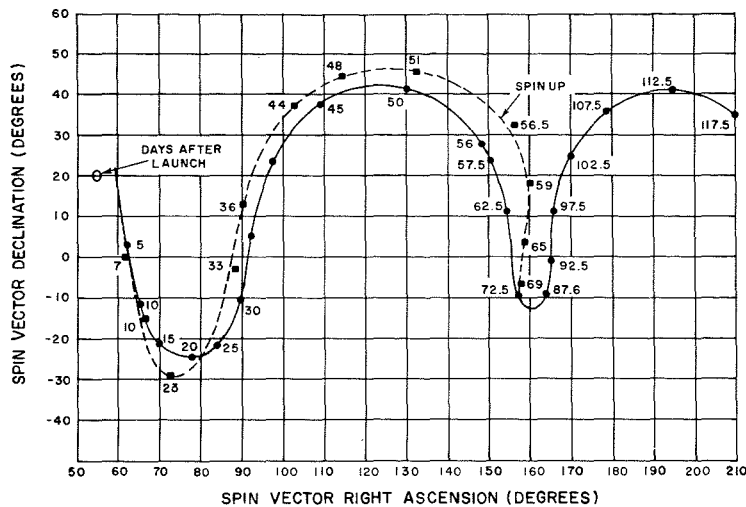

Fig. 5—Observed motion of the TIROS I spin vector based on an analysis of photographs (dashed line) compared with the theoretical motion based on the effects of a magnetic dipole moment along the spin axis and differential gravity (solid line). Declination is + north and - south of the celestial equator; right ascension is + east of the vernal equinox along the celestial equator. Increased stability of both the theoretical and observed motion is seen after spin-up on May 27 (56 days after launch). The last picture with clearly identifiable landmarks was received on June 9 (69 days after launch).

increasing (eastward) at a greater rate than previously.

Because of a torque exerted on the orbit by the earth's bulge, the orbit regressed (westward) around the equator $4.547^\circ/\text{day}$. It is apparent from Fig. 6 that if the spin vector were to remain fixed in space, the westward motion of the orbit would cause an angle to develop between the orbital plane and the spin axis. Since TIROS I has the shape of a short cylinder (19 inches high and 42 inches in diameter), the moment of inertia about its spin axis is larger than the other principal moments of inertia. Hence, when the angle between the orbital plane and the spin axis is greater than zero and less than 90° , a torque due to differential gravity (similar to that exerted by the sun and moon on the earth, causing its precession) will be exerted on the satellite. The nature of this torque was investigated but was rejected as the primary torque causing the observed forced precession, because it would have caused the spin vector to move northward instead of in the observed southerly direction.

The minimum spin vector declination of -30° was reached about April 23. At this time the orbit had regressed 100° and the unit vector n , normal to the orbital plane, lay in the same meridional plane as the unit vector s along the satellite spin axis. Shortly thereafter, when n developed a westerly component with respect to s and the satellite spin axis declination was observed moving northward, the possibility of a magnetic couple being the primary force became apparent and it

became the focal point of investigation.

A computer program was undertaken using the initial injection conditions of TIROS I on April 1, 1152 GMT. The results are plotted together with the observed motion of the spin axis in Fig. 5, and show excellent agreement. In this computer run, a time function for the spin rate was introduced reflecting its observed decrement from 10.0 rpm on April 1 to 9.4 rpm on May 27. (The decay in spin is due to a very small torque caused by eddy currents generated in the spinning satellite by the earth's magnetic field.) On May 27, a pair of spin-up rockets was fired at 2133 GMT, increasing the spin rate to 12.875 rpm. Greater stability was effected at higher values of the spin rate, and this increased stability can be seen in the plot after spin-up (Fig. 5).

The outcome of this investigation has indicated that the angular motion of

Fig. 6—Space coordinates.

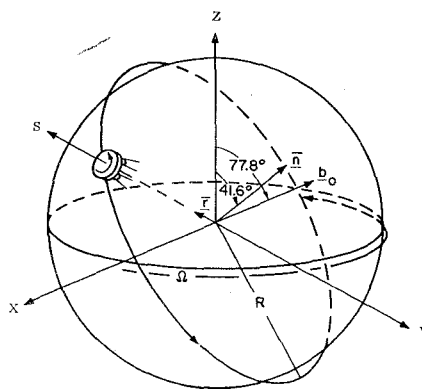

the spin axis of TIROS I can be explained quite well by considering two torques:

- 1) A primary torque caused by the interaction of an average magnetic dipole along the spin axis (caused by residual permanent magnetism of ferromagnetic materials and by closed current loops in the instrumentation) with the earth's magnetic field, and
- 2) A secondary torque caused by differential gravity in the earth's gravitational field.

Termination of Communications

The decision to discontinue attempts at interrogating TIROS I was made after orbit 1302 over Fort Monmouth about midnight Wednesday, June 29. The wide-angle camera system and all telemetry had ceased to function. (The 108.00-Mc tracking beacon continued to operate.)

There appears to be some limited operational capability remaining in the narrow-angle camera system. However, it would be extremely difficult, perhaps frequently impossible, for meteorologists to identify and orient the narrow-angle camera pictures. The satellite's attitude sensors are not working and there are no longer wide-angle photos, which frequently pick up identifiable geographic landmarks, to assist scientists in orienting narrow-angle cloud cover tv photos. An inoperative relay in the wide-angle camera system is the probable cause of the TIROS I difficulty. The malfunction made it impossible to turn off the transmitter. This apparently drained the batteries and eventually caused the transmitter to burn out. This damage seems to have affected the entire satellite system.

Of the total of 22,952 pictures received, it is estimated that over 60 percent represent good quality cloud cover photographs useful to meteorological research.

METEOROLOGICAL SIGNIFICANCE

Some time before the TIROS vehicle was launched, meteorologists decided that the largest initial effort with any pictures received should be the operational utilization of satellite weather information for synoptic (i.e., over-all) weather analysis on an experimental basis. This dictated that attention be restricted almost exclusively to the images received from the wide-angle camera. The temporary technical difficulties with the narrow-angle clock which occurred during the first 570 orbits did not have a significant affect on meteorological evaluation.

Cloud-Pattern Organization

The first major meteorological discovery was the high degree of organization of cloud patterns of all scales that occurs in the atmosphere. The limited view of clouds and their distribution prior to TIROS I only hinted that this might be true. The fact that such a high degree of organization does exist increases the utility of weather satellites, for distinctive, recognizable patterns naturally allow more information to be more rapidly culled from imagery data.

Storm Detection

Large-scale cloud and weather systems have been easily recognized. A fascinating discovery by TIROS I was that extratropical as well as tropical cyclones are characterized by a very distinct vortex or spiral-cloud pattern about their centers (Fig. 7). In addition, each individual storm seems to have some distinctive characteristics in its associated cloud pattern that marks it apart from other existing cyclones, so that a specific storm can be perhaps recognized even before confirmation of its identity is received from its actual location. This simplifies even more the task of tracking the weather observed on the pictures. A storm was observed off the coast of Madagascar and was easily tracked on the TIROS I images for five consecutive days. It has also been found that the weather fronts associated with such mid-latitude storms are striking and obvious on the images.

Another milestone in the early life of TIROS was the observation of typhoon north of New Zealand. Also of great significance was the inference, on a few occasions, of the location of the jet stream over the eastern Mediterranean from cloud bands observed on the satellite images. As an aid in the analysis of synoptic weather charts, TIROS I has proved itself, even at this time.

Cloud Identification

The degree to which cloud identification is possible with the wide-angle camera images is a function of the variables in the TIROS I images, such as the angle of view, angle of illumination and cloud-ground contrasts. However, there has been no time as yet to study effectively the effects of these variables. Thus, the conclusions drawn to date probably apply to a majority of the pictures viewed as part of the operational utilization experiment, but will certainly be modified as the above-mentioned variables are carefully studied and their unique effects removed from the more general picture.

It is possible to differentiate between stratiform and cumuliform clouds on

the TIROS I images (Fig. 8), although it is usually impossible to determine the height of the clouds in question. It appears that the very high clouds, the cirrus clouds, normally composed of ice crystal, are not recognized at all unless viewed at small nadir angles and with very sharp cloud-ground contrasts.

Clouds are not usually seen at all unless the cloud-cover amounts to at least somewhere between scattered and broken. The line that appears to be the edge of a cloud band or deck is actually where the cloud cover is decreasing to near scattered. Some exceptions to this conclusion have been found, again, in regions where a high cloud-ground contrast is viewed at small nadir angles. Incidentally, ice cover in the Gulf of St. Lawrence was seen and mapped from TIROS I images.

The variations in brightness of the cloud images over an area or the relative brightness of the clouds appear to be attributable to the variation in the thickness of the clouds. However, the absolute brightness of the cloud images depends on many factors in addition to cloud thickness. It is not unreasonable to assume that these other factors remain constant within limited areas, thus lending credence to the above conclusion.

There can be little doubt, in view of the information available from the wide-angle images, that intense detailed cloud analysis will be possible with the narrow-angle images. The few narrow-angle pictures that meteorologists have viewed have shown that very specific cloud types may often be recognized. In one case in particular, an extensive grayish area on a wide-angle image, thought simply to be ground of higher reflectivity, was very clearly shown to be an area of air weather cumulus cloud streets on a narrow-angle view.

Fig. 7—Wide-angle TV picture of a storm in the South Indian Ocean. The fine structure characteristic of storms over ocean areas and clockwise circular characteristic of southern-hemisphere storms are easily seen.

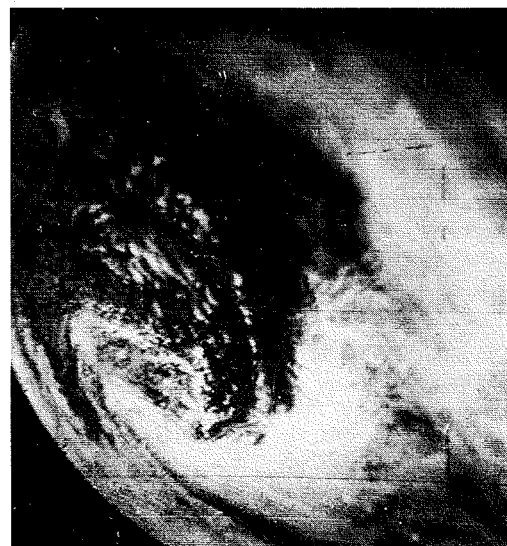

The meteorological utilization of the TIROS I imagery has been somewhat hampered because of the difficulty experienced in determining the attitude of the satellite, and because of some minor uncertainties as to the time the remote pictures were taken. These two problems both make it difficult at the present time to determine the position of the weather systems viewed, in the absence of recognizable landmarks. Since it is the ocean areas of the world where conventional weather data are most sparse, it is over the ocean areas that meteorologists would like to be able to most accurately position the information given them by TIROS I. This must await refinement, and possibly some reprocessing of the data presently available.

CONCLUSION

The second TIROS satellite was successfully orbited on Nov. 23, 1960. As of Feb. 13, 1960, TIROS II had completed 82 days of operation. In 1200 orbits it had returned over 20,000 tv pictures. [See *Corrington and Martinelli*, this issue, for additional information on TIROS II.]

The full potential of TIROS weather satellites is a long way from being fully and realistically estimated. The wealth of data obtained from TIROS I and II allows extensive further analysis of both meteorological and satellite-performance information. At this point, TIROS has dramatically shown the feasibility of short-term satellite weather forecasting and proven out hardware concepts through its effective production of data beyond all anticipation.

ACKNOWLEDGEMENTS

The authors would like to acknowledge the assistance of Dr. W. P. Manger, Dr. L. Krawitz, J. A. Strother, and J. R. Owens.

Fig. 8—Wide-angle TV picture of large cumulus clouds over Somaliland. The northeast tip of Somaliland is strikingly seen at the bottom center. Arabian peninsula is visible to the right across the Red Sea.

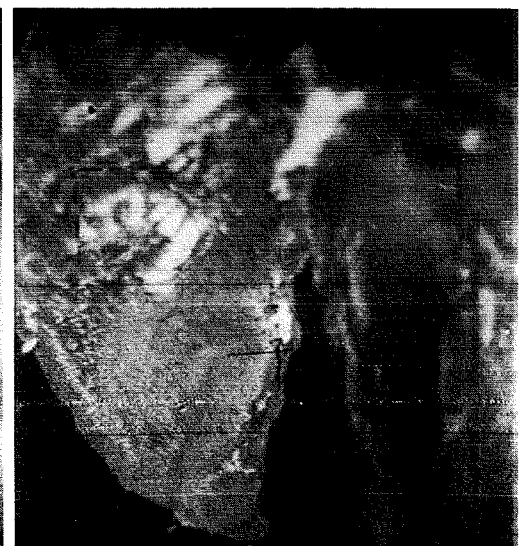

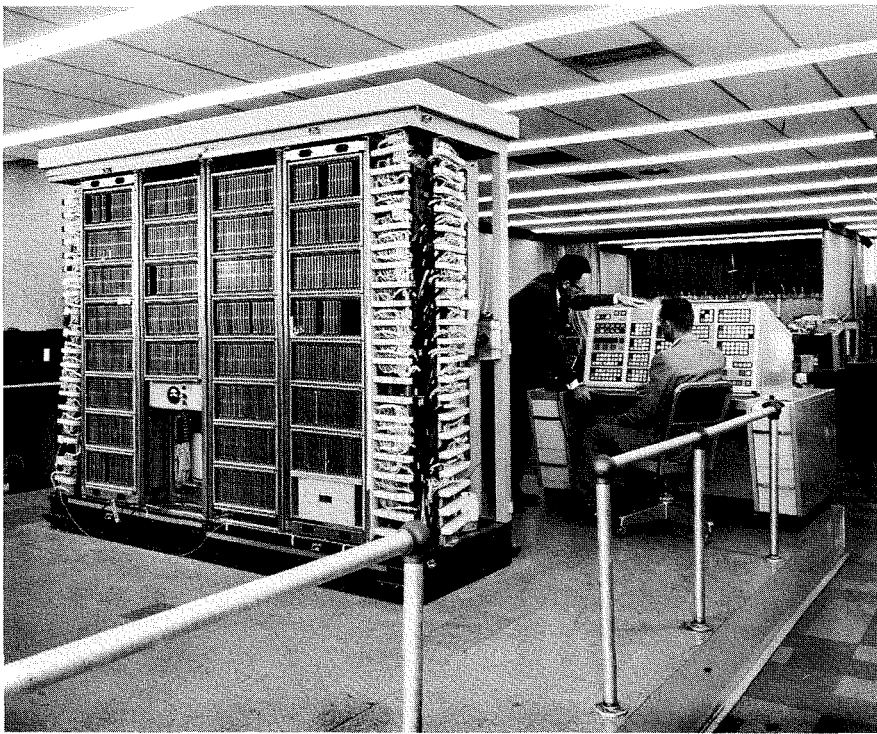

Fig. 1—The DIP computer and console at Van Nuys during final shakedown.

MILITARY APPLICATIONS OF COMPUTER TECHNIQUES

by **A. D. BEARD, MGR.**

Digital Systems Engineering

West Coast Missile and Surface Radar Division

DEP, Van Nuys, California

THE ENGINEERING and production of computer systems to meet the requirements of military missions is an important activity of the West Coast Missile and Surface Radar Division. It is the purpose of this article to give insight into the nature of these applications and to describe some of the concepts of the continuing program of advanced development at Van Nuys.

AUTOMATIC CHECKOUT

Automatic checkout and monitoring systems are concerned with the collection, analysis, and recording of signals used to evaluate the system under test. Very often, these systems include the generation and control of certain stimuli signals in order to test for required responses. Typical applications include such RCA programs as the Atlas missile checkout system, the checkout and monitoring system for BMEWS, and the DAMP ship data-collection system.

Flexibility of programming and control is a required feature of these systems. The computer must be able to facilitate analog as well as digital inputs and outputs. Operation speed of the checkout equipment may vary from the relatively slow speeds used in ballistic-missile checkout, where the speed of operation is limited by the vehicle under test, to the high-speed checkout require-

ments of BMEWS, where actual raids must be simulated and system response analyzed at electronic speeds.

REAL-TIME CONTROL

Real-time computer applications involve automatic control of a system, usually in response to a high-speed data-collection network. One example would be the trajectory control of a missile to destroy an incoming target, based on position information gathered from a tracking radar. Other examples include range safety computations, weapon direction centers, radar and sonar target-detection systems, and navigation systems.

Characteristic requirements of these applications are high-speed computation and rapid servicing of input and output channels (many input and output signals are analog). Reliability is another crucial factor, since unscheduled down time may be catastrophic.

OPERATIONS CONTROL

An operations control system is one in which data pertinent to the conduct of a given military mission is collected, analyzed, and displayed to personnel responsible for decisions and the conduct of a tactical or strategic operation. One example is the NORAD (North American Air Defense) Command Center, at Colorado Springs; this system

determines when the country is under attack from airplanes or missiles, and automatically assigns defensive weapons to meet this attack. Other operations control applications include bomb-damage assessment centers, field-army tactical operation centers, air-traffic control centers, and intelligence centers.

These applications may be considered semi-real-time. Quickness of response is important. New data must be analyzed in conjunction with previous data and presented for military interpretation usually in a matter of minutes or seconds. These applications require rapid storage and retrieval of large quantities of data, high-speed processing, and high-speed servicing of communication links and displays. To accommodate the rapidly changing nature of military operations, it is important that the computing system be highly flexible. It is important that the system be capable of expansion, since the magnitude of the tasks may grow considerably during its lifetime.

Another requirement is the facilitation of communications between the personnel making decisions and the data handling machine system.

"DIP"—EXAMPLE OF A MILITARY INFORMATION PROCESSOR

The *Display Information Processor* (DIP) illustrates how some of the above

A. B. BEARD received his B.E.E. (1947) and M.E.E. (1949) from the Rensselaer Polytechnic Institute and was an EE instructor there in 1947-49. He joined RCA Advanced Development in 1949, and contributed to analog techniques for Shoran. He was then made Project Engineer on the prototype Bizmac. Later, he was made responsible for advanced-development programs in military computers and displays, such as transistorized time-division multiplex equipment, USAF time-division data link, high-speed encryption equipment, interceptor fire-control, military TV, and solid-state electro-luminescent displays. His activity was responsible for a company-sponsored air-traffic-control study that recommended a national system of air-traffic control to the Air Modernization Board. In 1958, he took over the Digital Development and Design activity at Moorestown, concerned with major data-processing equipment for DAMP and BMEWS. He moved to his present post at the West Coast Missile & Surface Radar Division in 1959. Mr. Beard is a member of the Eta Kappa Nu, Tau Beta Pi, Sigma Xi, and has ten patents.



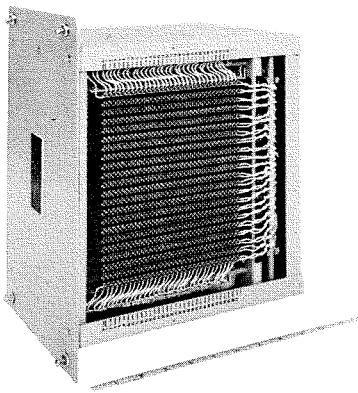

Fig. 2—A 4096 x 22 bit ferrite core memory.

mentioned requirements have been met in handling BMEWS information at the NORAD Command Center.

DIP processes BMEWS data received from the forward radar sites and displays this data to the NORAD Command. The DIP computer (Fig. 1) was designed to be an ultra-reliable solid-state machine utilizing general-purpose techniques, with particular emphasis on the real-time input-output requirements. Since this application demands uninterrupted operation, considerable design effort was expended to provide many special features which virtually eliminate down time. The general characteristics of this solid-state digital computer are:

- 1) parallel binary number representation
- 2) 19-bit precision
- 3) $\frac{2}{3}$ -Mc basic clock
- 4) 12.8- μ sec machine cycle
- 5) 25.6- μ sec instruction time
- 6) single-address instruction
- 7) stored-program operation
- 8) high-speed random-access magnetic-core memory, 4096-word capacity
- 9) memory parity check features
- 10) nonvolatile program back-up, two 4096-word fields on a magnetic drum

Fig. 3—A 1024 x 22 bit ferrite plate memory.

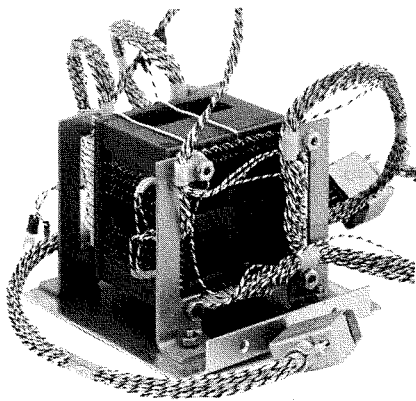

- 11) automatic program reload on machine-detected errors
- 12) program reload feature available to programmer for program-detected errors
- 13) three index registers
- 14) 24 programmed input-output channels
- 15) multiplexed exchange system for fast servicing of real-time inputs and outputs

The primary function of DIP is to receive asynchronous data from three forward sites (plus manual inputs from NORAD), process this data, and send the results to displays at both NORAD and SAC. This extensive input-output problem demands high-speed servicing by the computer. The multiplexed-exchange system allows the external equipment to break into the main program sequence at the end of any instruction and force the input-output instruction to occur. At the finish of the input-output operation, the program resumes its normal sequence from the point at which it was interrupted. The entire process, from external request to completion of the servicing, requires from 25.6 to 51.2 μ sec.

Since a stored-program machine with a random access core memory is susceptible to transient errors during the memory regeneration cycle, an error-detection-and-correction system was included in the DIP logic. The entire operational program is stored on a non-volatile magnetic drum. Upon the detection of a memory parity error, the machine control is transferred to the drum timing, and the entire program is taken from the drum and regenerated into the high-speed core memory. The memory locations which contain valuable data are not disturbed by the program regeneration. This program reload function requires from 67 to 134 msec to complete. This ensures that not more than one message per site could be lost due to a transient error.

Another feature of the DIP system is an on-line checkout loop which continually sends test messages from the output of the computer, through the receiving communication equipment and back into the computer. These test messages are interleaved with real messages from the sites and may be sent at a rate of eight messages per second. The computer verifies that the correct message has been received and may process the message or discard it, depending upon the mode of operation in which the computer is at the time. This checkout loop not only performs a running test on the input equipment but also may be used to pinpoint failures in this area.

The DIP system includes a variety of alarm indications which are displayed at the maintenance console and may also be typed out on the hard-copy printer. Examples of detected alarms are: *input not accepted*, *input data parity error*, *memory parity error*, *closed program loop*, *output not accepted*.

Upon detection of an error, the operator must determine if the alarm was caused by a transient error or a catastrophic failure. When the failure was catastrophic, the computer is switched to the maintenance mode, and a diagnostic program is inserted into the core memory from the program back-up drum. The diagnostic program pinpoints the area in which the fault has occurred. The maintenance operator may then quickly determine which module should be replaced. This diagnostic routine is most effective when the basic machine cycle has not been affected by the fault.

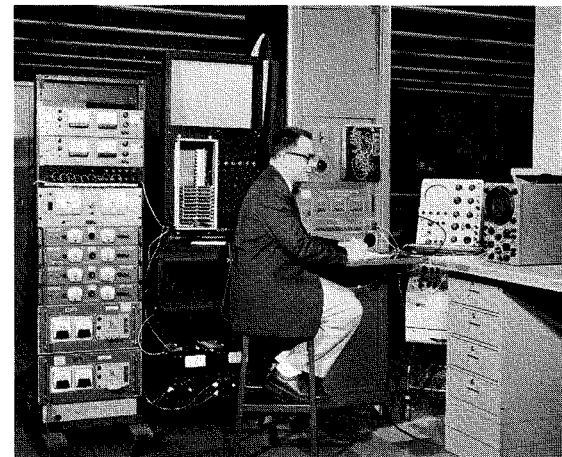

Fig. 4—T. A. Grady, Design and Development Engineering, performs memory experiments with a universal memory test set.

This automatic-fault-location routine considerably reduces the down time required for a catastrophic failure.

Several special design techniques are used to enhance the reliability:

- 1) *End-point circuit design*—the design is such that all components in a circuit may drift to the tolerance limits without affecting the circuit operation.
- 2) *Short-proof circuits*—the majority of the circuits are designed to allow the output to be shorted to ground without causing a catastrophic failure.
- 3) *End-point logic design*—the logic is designed to operate with all logic elements having the worst-case calculated delay, a safety factor of about 3:1 above average.
- 4) *Two-phase logic*—used in place of the conventional differentiating circuits—reduces the sensitivity of the circuits to random noise pulses.

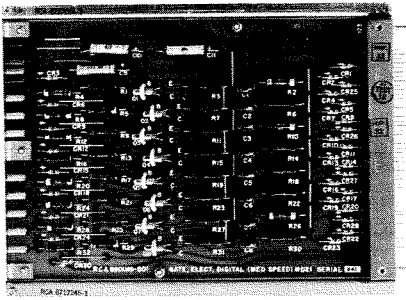

Fig. 5—A BMEWS medium-speed gate module.

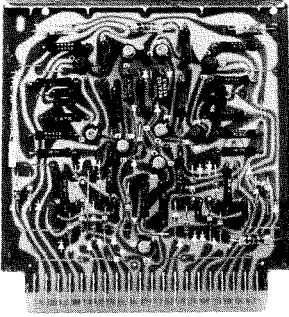

Fig. 6—A Pine Tree 10-Mc gate module.

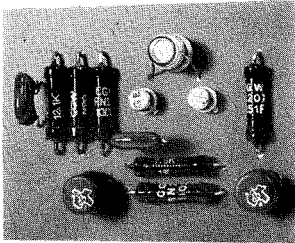

Fig. 7—A high-speed tunnel-diode comparator capable of 5-Mc operation.

- 5) *Automatic power-supply monitoring*—each power supply is monitored and is automatically sequenced off when any supply in the system varies beyond the preset limits. This protects the circuits from damaging overvoltage.

The maintenance console displays the contents of all the major registers and control circuits of the machine. In the maintenance mode, the operator may set up desired numbers, modes of operations, program stop points, and other useful conditions which help to diagnose problems by the most efficient method.

BUILDING-BLOCK READINESS

In order to respond quickly to military requirements, it is necessary to carry on a continuing program of advanced investigations including technique, hardware, logic and system studies. The technique programs provide the basic building blocks from which computer systems may be evolved. The logic and system studies provide a base for new machine concepts to meet the ever changing military requirements.

Memories

High-speed memory devices are fundamental computing elements. Fig. 2 shows a memory presently being used in equipments supplied to the BMEWS system. Fig. 3 is a memory which uses ferrite plates instead of cores. Development programs presently in process are directed toward extra-fast memories with 0.8- μ sec access time for a complete read-write cycle, and 0.3- μ sec for a nondestructive read-out. In addition, a nondestructive multi-load Transfluxor memory is being investigated which would permit simultaneous, independent addressing from several processors.

Fig. 4 shows a special purpose test equipment used for experimentation with developmental memories.

Circuits

Other fundamental building blocks are the circuits used for switching, storage, amplification, and analog-to-digital conversion. These circuits are packaged on plug-in units for ease of construction and maintenance. Fig. 5 shows a circuit module presently being used in all of the RCA-designed BMEWS equipment. Fig. 6 shows a 10-Mc Pine-Tree circuit module for a specialized data-processing equipment. Fig. 7 is a tunnel-diode comparator which acts as the heart of a very-high-speed analog-to-digital converter system.

Peripheral Equipments

Investigations are being performed in the area of input-output equipments. Fig. 8 shows a model of a high-speed tape loop being investigated as a buffer storage medium which will contain some 10,000,000 bits of information. The average access time to any one of these stored bits is $\frac{1}{2}$ second. Fig. 9 shows an electroluminescent storage indicator presently under investigation to meet the requirements of military display systems. The display utilizes only solid-state

electroluminescent and photoconductive elements.

Advanced Machine Organization

In addition to the hardware investigations, entire machine concepts are being studied. Fig. 10 shows a drum-type computer being investigated for portable military operations. Other studies have produced the MR 8500, a real-time control system designed around a high-speed, solid-state computer. The computer is designed with primary emphasis on reliability and versatile real-time input-output features. Both random-access storage (coincident-current magnetic-core memory) and nonvolatile program back-up storage are utilized—the former to obtain a fast access storage for use during normal computer operation and the latter to guard against loss of program information in the event of transient errors or power failures.

A somewhat smaller system, the MR 3502, fills the need for a compact, reliable and highly flexible data processor designed to handle a wide variety of data reduction and data handling activities. The machine has been designed for compactness, ruggedness, serviceability and extreme reliability; it will operate with no air conditioning in an environment from 0 to 50°C. Both the MR 8500 and the 3502 feature a powerful program interrupt system which facilitates the servicing of communication lines and peripheral equipments.

SUMMARY

The engineering of military computer systems requires approaches geared to meet ever-changing requirements. These approaches are typified by the BMEWS Display Information Processor. The DEP West Coast Missile and Surface Radar Division is actively pursuing this specialized computer field through advanced-development programs keyed to building-block readiness to meet quickly new military needs.

Fig. 8—L. Fiderer (l.) and C. M. Malone, Design and Development Engineering, perform tests on a high-speed memory.

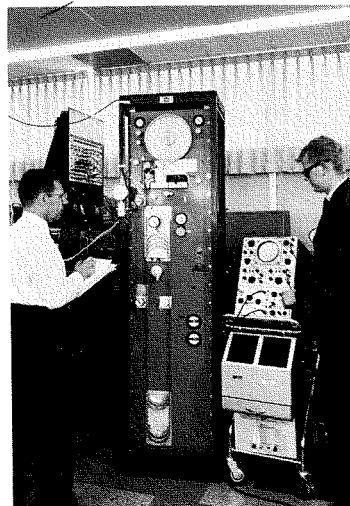

Fig. 9—An electroluminescent storage indicator for displaying numbers and characters.

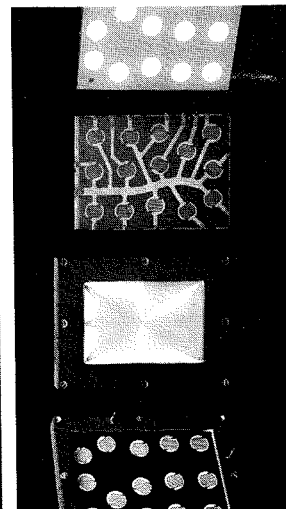
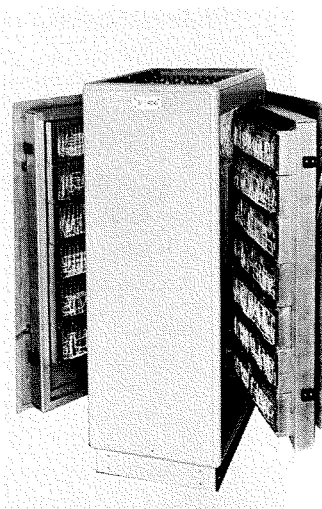
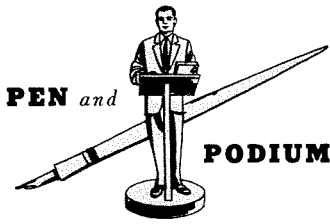

Fig. 10—Experimental computer with magnetic drum as internal memory.





BASED ON REPORTS RECEIVED OVER A PERIOD OF ABOUT TWO MONTHS

ELECTRON TUBE DIVISION

Modern Microwave Traveling-Wave Amplifiers
H. K. Jenny: *Bulletin of Swiss Electrical Society*, October 8, 1960

Status Report on the Environmentalization of Traveling-Wave Tubes
J. S. Posner: *Electronic Design*, October 12, 1960

The Modern Use of Tolerances
D. Colasanto: *Production*, November 1960

Construction and Analysis of Input Admittance Chassis
M. Fomin: *Electronic Equipment Engineering*, December 1960

Miniaturized 5-Band Traveling-Wave Tubes Using Periodic Permanent Magnets
H. J. Wolkstein, C. L. Cuccia: *Electronic Industries*, December 1960

Improved Product Detection with a Beam-Deflection Tube (7360)
J. M. Filipczak: *QST*, December 1960

On the Ultimate Sensitivity of an Imaging Process
O. H. Schade, Sr.: Scientific and Technical Group of the Royal Photographic Society of Great Britain and *Proceedings of Meeting*, December 1960

Multiplier Phototube and Photoelectric Tube
J. L. Weaver: *Encyclopedia of Science and Technology*, October 1960

Television Camera Tubes
R. G. Neuhausen: *Encyclopedia of Science and Technology*, October 1960

Kinescope
C. P. Smith: *Encyclopedia of Science and Technology*, October 1960

Storage Tubes and Cathode-Ray Tube
M. D. Harsh: *Encyclopedia of Science and Technology*, October 1960

Practical Tubes for Bright Radar Display
F. S. Veith: *Bulletin of Swiss Electrical Society*, October 8, 1960

Phosphor Efficiency at Very Low Excitation Current Densities
G. W. Francis, R. G. Stoudenheimer: *Review of Scientific Instruments*, November 1960

Coil Springs for Filament Tension, Super-Low-Frequency Triodes
E. J. Hills: *Steel*, November 1960

Thermionic Converters
F. G. Block: Panel Discussion sponsored by Johns Hopkins University, November 17, 1960

Theory and Performance of an Electrostatically Focused High-Power Traveling-Wave Tube
W. W. Siekanowicz: *Proceedings of the IRE*, November 1960

SEMICONDUCTOR AND MATERIALS DIVISION

Electrode Potentials
R. Glicksman: *Encyclopedia of Science and Technology*, October 1960

Semiconductor Devices—Their Status and Future
E. O. Johnson: *Space Aeronautics*, December 1960

Future of Solid-State Devices
A. Blicher: AIEE Section Meeting, Philadelphia, Pa., December 6, 1960

Preparation and Properties of Low-Loss Ferrites
A. P. Greifer, Y. Nakada, H. Lesoff: Conference on Magnetism and Magnetic Materials, New York City, November 1960

Ferrite Thin Films
H. P. Lemaire, W. J. Croft: Conference on Magnetism and Magnetic Materials, New York City, November 1960

INDUSTRIAL ELECTRONIC PRODUCTS
Noise and Distortion in a Microwave Radio Relay System
D. G. Hymas: Master Thesis, Moore School, University of Pennsylvania, June 1960

Recent Developments in Electron Microscopy
J. H. Reisner: Eastern Analytical Symposium, New York, November 14, 1960

Calculated Waveforms for Tunnel Diode Locked Pair
H. R. Knapp, D. R. Crosby: Eastern Joint Computer Conference, New York, November 15, 1960

The RCA 601 System
A. T. Ling, K. Kozarsky: Eastern Joint Computer Conference, New York, November 13, 1960

Data Communications Facilities, Techniques and Equipment for the EDP User
R. E. Montijo: San Diego Chapter of Association for Computing Machinery, San Diego, California, November 1960

Operations Research
S. I. Neuwirth: Meeting National Machine Accountants, Buffalo, New York, December 1960

Product R & D—Is It Balanced by Adequate Marketing R & D
C. O. Caulton: Seminar on Marketing Problems, Cleveland, Ohio, November 17, 1960

RCA VICTOR HOME INSTRUMENTS

Design Characteristics of Nonvented Nickel Cadmium Cells
L. M. Krugman: IRE Transactions on Component Parts, December 1960

RCA VICTOR RECORD DIVISION

Cancellation of Sine Waves
J. J. Davidson: *Electronic Industries*, November 1960

Transistor AC Amplifier with High Input Impedance
J. J. Davidson: *Semiconductor Products*, March 1960

RCA SERVICE COMPANY

An Approach to Maintainability Measurement and Prediction
H. Kennedy, B. L. Retterer: Electronic Industries Association Conference, San Antonio, Texas, December 5, 6, 7, 1960

DEFENSE ELECTRONIC PRODUCTS

Plasma Acceleration by a Quasi-Static R-F Electric Field Gradient
T. T. Reboul, G. D. Gordon, G. A. Swartz: Annual American Rocket Society Meeting, December 7, 1960

An Electronic Pictorial Data System for Satellites
R. T. Callais: Aberdeen Area Group, AIEE, Aberdeen Proving Ground, Maryland, October 18, 1960

Psychological Influences in Standardization
M. S. Gokhale: 9th Annual Meeting Proceeding Pittsburgh 1960, Standards Engineers Society, Washington, D. C., November 1960

Logical Design of a Universal Programmed Automatic Checkout System
P. Bokros, D. Caplan: 7th East Coast Conference, October 26, 1960

External Interpolatory Problems in the Unit Disc
Dr. J. Minker, B. Epstein: *Proceedings American Mathematical Society*, October 1960

Guidance and Control for Satellite Intercept
H. S. Broadwell: American Ordnance Association, Cleveland, Ohio, October 20, 1960

On the Design of an Aspheric Mangin Mirror for 8.6mm Radiation
R. C. Gunter, Jr.: Optical Society of America Meeting, Boston, Mass., October 12, 1960

Infrared Vidicon Measurements of Missile Plumes
R. B. Merrill, D. A. Page: 4th National IRIS Symposium, Boston, Mass., October 10, 1960

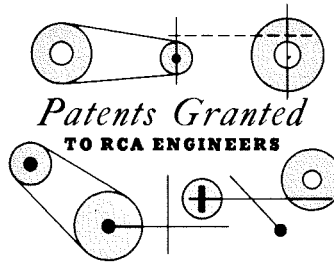

BASED ON SUMMARIES RECEIVED OVER A PERIOD OF ABOUT TWO MONTHS

DEFENSE ELECTRONIC PRODUCTS

Magnetic Erase Head
2,959,643—November 8, 1960; E. R. Robson.

Electromechanical Resolver
2,963,696—December 6, 1960; R. H. Peterson and G. S. Black.

Sweep Circuit
2,959,750—November 8, 1960; S. Dobren and E. G. Lurcott, Jr.

Modulator of the On/Off Type
2,962,669—November 29, 1960; J. Mahler.

Television Receiving Systems
2,964,674—December 13, 1960; T. Murakami and B. V. Vonderschmitt.

Magnetic Structure
2,963,557—December 6, 1960; L. J. Anderson.

System for Narrow-Band Transmission of Pictorial Information
2,957,941—October 25, 1960; F. D. Covely, 3rd.

Composite Photography
2,961,920—November 29, 1960; L. T. Sachtleben.

Information Handling System
2,961,643—November 22, 1960; W. R. Ayres and J. N. Smith.

Linear Wave Generator
2,965,770—December 20, 1960; S. W. Lewinter.

Antenna
2,965,898—December 20, 1960; E. S. Lewis.

SEMICONDUCTOR AND MATERIALS DIVISION

Jig Alloying of Semiconductor Devices
2,964,431—December 13, 1960; I. H. Kalish and S. Silverstein.

Television Receiving Systems
2,964,674—December 13, 1960; B. V. Vonderschmitt and T. Murakami.

Low Noise Receivers in Large Microwave Array Radars
W. E. Sievers, W. H. Ramsey: Symposium Application of Low Noise Receivers to Radar and Allied Equipment, Lexington, Mass., October 24, 1960

On an Explicit Method for the Solution of a Stefan Problem
W. F. Trench: *Journal of Society for Industrial Applied Mathematics*, Vol. 7—No. 2, June 1959

On Periodicities of Certain Sequences of Residues
W. F. Trench: *American Mathematical Monthly*, Vol. 67, No. 7—August-September 1960

BMEWS—Automatic Monitoring Systems
M. Korsen, E. L. Danheiser: WESCON, Los Angeles, August 26, 1960

A System of Micro-Miniaturization—The Micro-Module
M. Bondy: 6th Annual Instrument Show, Philadelphia, November 9, 1960

Low Noise Preamplifier Investigation
John Klein, Knowlton Miller: *Records of the NEREM Show*, Boston, November 16, 1960

RCA VICTOR COMPANY, LTD.

Improvements in Encapsulated Silicon Junction Alpha Detectors
R. W. Jackson, P. P. Webb, R. L. Williams:

RCA VICTOR HOME INSTRUMENTS

Alert Radio Signal Receiver
2,958,770—November 1, 1960; J. M. Link and J. J. Davidson.

Loudspeaker Magnetic Field Structure
2,964,597—December 13, 1960; R. E. Hamson.

High Frequency Tuner Having Temperature Compensating Means
2,959,743—November 8, 1960; W. Y. Pan.

Push-Pull Amplifier Circuits
2,959,640—November 8, 1960; J. B. Schultz.

INDUSTRIAL ELECTRONIC PRODUCTS

Electron Beam-Controlling Apparatus
2,963,607—December 6, 1960; B. R. Clay.

Shift Register Circuits
2,963,688—December 6, 1960; H. Amemiya.

Kinescope Background Control System
2,965,705—December 20, 1960; A. C. Luther, Jr.

Marker Pulse Circuit
2,965,845—December 20, 1960; R. W. Sonnenfeldt.

Detection Apparatus
2,957,982—October 25, 1960; R. W. Sonnenfeldt and G. M. Daly.

RCA VICTOR RECORD DIVISION

Alert Radio Signal Receiver
2,958,770—November 1, 1960; J. J. Davidson.

ELECTRON TUBE DIVISION

Traveling Wave Tube
2,964,670—December 13, 1960; E. E. Bliss.

Stem and Envelope for Electron Discharge Devices
2,960,620—November 15, 1960; A. J. Stoekert.

Anode Top-Cap Assembly for Electron Discharge Devices
2,962,619—November 29, 1960; G. M. Rose, Jr.

High Perveance Electron Tube
2,957,999—October 25, 1960; J. W. Gaylord.

Variable Drive Apparatus
2,964,971—December 20, 1960; W. Blydenburgh

Automatic Rolling Machine
2,964,979—December 20, 1960; R. H. Pollock and R. W. Cox.

Hermetic Seal and Method of Making the Same
2,965,962—December 27, 1960; J. Ollendorf and H. R. Meisel.

IRE 7th Annual National Meeting Professional Group on Nuclear Science—Solid State Radiation Detectors, Gatlinburg, Tenn., October 3 and 5, 1960

Transistor Form of Nuclear Particle Detectors
R. L. Williams and P. P. Webb: IRE 7th Annual National Meeting of the Professional Group on Nuclear Science—Solid State Radiation Detectors, Gatlinburg, Tenn., October 3 and 5, 1960

Mechanical Aspects of Electronic Equipment Reliability
I. Kirkpatrick: IRE Professional Group on Reliability and Quality Control, New York City, October 14, 1960

Cartesian Tensors and Spherical Harmonic Expansions in the Boltzmann's Equation
T. W. Johnston: Second Annual Meeting of the Division of Plasma Physics of the American Physical Society, Gatlinburg, Tenn., November 2-5, 1960

Conductivity Values for any Degree of Ionization Based on a Maxwellian Distribution
I. P. Shkarofsky: Second Annual Meeting of the Division of Plasma Physics of the American Physical Society, Gatlinburg, Tenn., November 2-5, 1960

Nature of Electromagnetic Waves in Non-Homogeneous, Anisotropic Plasmas
M. P. Bachynski: Second Annual Meeting of the Division of Plasma Physics of the American Physical Society, Gatlinburg, Tenn., November 2-5, 1960

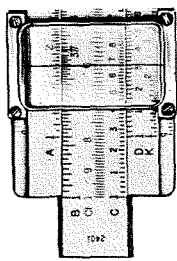

HSUEH AND FORBES WIN FIRST TWO IEP "ENGINEER OF THE MONTH" AWARDS

Industrial Electronic Products has named the first recipients of their newly established *Engineer of the Month* awards. **C. Y. Hsueh**, of Commercial Systems Engineering, Electronic Data Processing Division, received the inaugural January 1961 award for his work on the RCA 601 computer. The February award went to **E. J. Forbes**, Microwave Dept., Industrial Controls, for his work on the RCA MM-600 transmitter.

Mr. Hsueh was honored for his outstanding professional contributions in the design of a very high speed memory for the RCA 601 computer. Mr. Hsueh's participation in this timely development of one of the fastest memories yet announced required the application of a high order of professional skill and technical ability.

Mr. Forbes was honored in recognition of his outstanding contributions to the design of the transmitter for the RCA MM-600 6-kmc microwave equipment and its integration into the system. The manner in which Mr. Forbes solved many types of difficult problems in connection with this development is indicative of a high degree of professional skill and judgment. Mr. Forbes is a member of the MM-600 Design Group of which **R. F. Privett** is the Leader.

The new *Engineer of the Month* awards were inaugurated by IEP management to recognize outstanding professional contribution by members of the Engineering Staff. Each award in the series of six will be made to the IEP Engineer (or team of engineers) making one of the most significant engineer-

ing contributions in the preceding six months. Emphasis will be placed on recognizing any facet of the engineer's or group's endeavor which contributes to the total engineering effort. Nominations for IEP *Engineer-of-the-Month* are made by the Chief Engineers, with final selection for the award made by an engineering management committee.—*S. F. Dierk*

RCA AWARDS 63 UNDERGRADUATE SCHOLARSHIPS

RCA has awarded 63 undergraduate scholarships for the current academic year to assist students preparing for careers in science, industry, the arts, and teaching. **Dr. Irving Wolff**, Chairman of the RCA Education Committee, announced that the list includes 31 RCA Scholarships, 30 RCA Science Teacher Scholarships, and 2 RCA Institutes Scholarships. Of the 31 RCA Scholars, 27 are majoring in physics, chemistry, or engineering.

The thirty RCA Science Teacher Scholarships were made to students preparing to teach science in the nation's school systems. Twenty of the Science Teacher Scholarships were awarded to upperclassmen and are valued at \$800 each, while the remaining ten are valued at \$250 each and were awarded to freshman and sophomore students. In addition, the scholarship at Trenton State College in New Jersey includes a stipend of \$1,200 for each of two summers of graduate study in the science subject of the recipient's choice.

The remaining two scholarships, carrying a grant of \$800 each, were awarded to graduates of RCA Institutes to attend the college of their choice.

The 63 undergraduate scholarships are a part of RCA's program of aid to education which each year helps more than eighty young men and women further their education at more than fifty American colleges and universities. Fellowships for graduate study make up the balance of the program.

Winners of RCA Scholarships, other than those granted to graduates of RCA Insti-

TWELVE RCA FELLOWSHIPS VALUED AT \$4,000 EACH AWARDED

RCA Fellowships have been awarded to twelve graduate students for advanced studies in engineering, physics, dramatic arts, journalism, and science teaching. **Dr. Irving Wolff**, Chairman of the RCA Education Committee, announced that these RCA Fellowships, valued at approximately \$4,000 each, are a part of RCA's program of providing financial assistance to more than eighty young men and women each year at more than fifty American colleges and universities.

Since their inauguration in 1947, RCA Fellowships have been awarded to more than 140 graduate students. Each Fellowship includes full tuition costs, \$2,100 toward the student's living expenses, and \$750 as an unrestricted gift to the university attended by the RCA Fellow.

Eight of the Fellowships have been awarded for graduate study and research in physics, electrical engineering and engineering physics. Two other Fellowships have been designated as RCA-NBC Fellowships and are awarded jointly by RCA and the National Broadcasting Company for advanced study in dramatic arts.

One Fellowship, designated as the "Earl Godwin Memorial Fellowship," is awarded each year to a qualified employee of an NBC affiliated radio or television station for graduate study in journalism at Columbia University.

The remaining Fellowship, The RCA Science Teaching Fellowship at Purdue University, supplements compensation received by the Fellow from Purdue as a part-time teacher.

Except for the Godwin Fellow, selection of the following recipients was made by the universities where the Fellowships are maintained, subject to the approval of the RCA Education Committee.

tutes, are selected by officials of the school they attend, subject to approval by the RCA Education Committee. In addition to the grant to each student, RCA has made an unrestricted contribution of \$500 to each of the independent colleges and universities maintaining the scholarships.



Above, C. Y. Hsueh; below, E. J. Forbes.

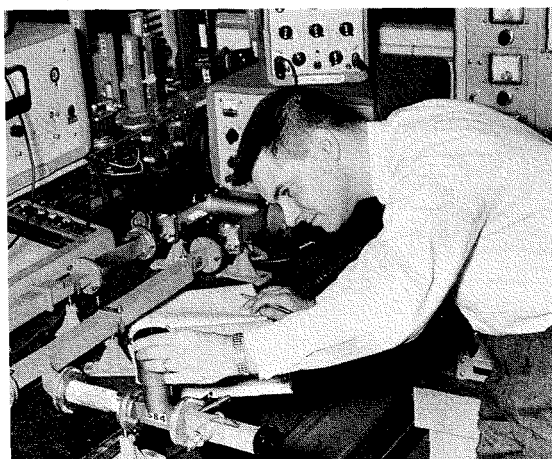

MOUNTAINTOP SEMICONDUCTOR PLANT BEGINS PILOT PRODUCTION

With pilot production of transistors already under way, the new Mountaintop, Pa. plant of the RCA Semiconductor and Materials Division is being geared for full-scale production of several million transistors and other semiconductors a month. The plant, scheduled for full-scale production by spring 1961, is one of the world's largest facilities devoted exclusively to semiconductor products. Its product line will include both germanium and silicon devices in the low, medium, and high power ranges.

W. H. Wright is Plant Manager of the

Mountaintop facility, which also has an engineering laboratory for development of new products and manufacturing techniques, and building and testing new electrical circuit applications.

In addition to Mountaintop and the parent Somerville, N. J., plant, which specializes in computer transistors and micromodules, the Semiconductor Division operates a plant at Findlay, Ohio, which produces transistors for use in home instruments and one at Needham, Mass., which turns out ferrite memory cores for computers.

ENGINEERS IN NEW POSTS

In the IEP Electronic Data Processing Division, **J. N. Marshall**, Mgr., Advanced Systems Development Engineering, has named **J. A. Brustman** as Mgr., Electronic Systems Engineering; he also named **R. K. Lockhart** as Mgr., Development Engineering for a U. S. Navy high-speed computer project. **F. G. Wenger** has been named Mgr., Production Planning for the EDP Division, replacing **R. M. Bradley**. For the new Palm Beach, Fla., computer plant, **H. M. Emlein**, Operations Mgr., has named **H. N. Morris** as Engineering Mgr., and **J. Toyzer** as Mgr., Manufacturing Engineering.

In IEP, **F. P. Barnes** has been named Mgr., Communications Products Dept., with responsibilities for operations in the Canonsburg area. For the Communications and Controls Division, **R. L. Holtzheimer**, Plant Mgr., Camden Commercial Plant, announces his staff as follows: **R. M. Bradley**, Mgr., Industrial, Audio, and Special Products Manufacturing; **A. C. Grover**, Mgr., Broadcast and High-Power Transmitter Manufacturing; **R. V. Levins**, Mgr., Manufacturing Engineering; **H. E. Lewis**, Mgr., Materials Operations; **T. W. McIntyre**, Mgr., Broadcast Audio, Video, and EDP Manufacturing; and **F. Weber**, Mgr., Magnetic Heads Manufacturing.

C. H. Colledge, Division Vice President and General Mgr., IEP Broadcast and TV Equipment Division, names his staff as follows: **A. F. Inglis**, Mgr., Closed Circuit TV and Film Recording Dept.; **E. N. Luddy**, Mgr., High Power Electronics and Nucleonics Dept.; **J. P. Taylor**, Mgr., Marketing Administration; **E. C. Tracy**, Mgr., Broadcast Equipment Dept.; **M. A. Trainer**, Mgr., Electronic Recording Products Dept.; **V. E. Trouant**, Chief Engineer, Engineering; **J. W. Wentworth**, Mgr., Educational Electronics; and **H. W. Wyllie**, Mgr., Administration. Mr. Luddy's staff includes: **J. E. Young**, Mgr., Transmitter Equipment Engineering. Under Mr. Young are: **T. J. Boerner**, Mgr., High-Power Transmitter Engineering; **R. G. Galbraith**, Mgr., Transmitter Equipment Engineering Administration and Drafting; **H. E. Gihring**, Mgr., Antenna Engineering; **C. D. Kentner**, Mgr., Broadcast Transmitter Test and Measuring Equipment Design; **R. B. Marye**, Mgr., Low-Power

Transmitter Engineering; and **J. C. Walter**, Mgr., High-Power Radar Transmitter Engineering. Under Mr. Tracy, **T. M. Gluyas** is Mgr., Broadcast Studio Engineering. Under Mr. Trouant, **F. C. Blancha** is Coordinator, Mechanical Design; **A. E. Garrod** is Mgr., Drafting; **W. R. Johnson** is Mgr., Engineering Services; and **H. N. Kozanowski** is Mgr., TV Product Advanced Development.

In the SC&M Division, **H. E. Knauf** has been named Mgr., Equipment Development, under **E. O. Johnson**, Chief Engineer.

In the Electron Tube Division, **D. Y. Smith**, Vice President and General Mgr., announces the following members of his staff: **H. F. Bersche**, Mgr., Distributor Products Dept.; **C. E. Burnett**, Division Vice President, Industrial Tube Products Dept.; **L. R. Day**, Mgr., New Business Development; and **J. B. Farese**, Division, Vice President, Entertainment Tube Products Dept. In the latter Dept., **J. T. Cimorelli**, Mgr., Engineering, Receiving Tube Operations, names his staff as follows: **R. F. Dunn**, Mgr., Receiving Tube Dept.; **N. S. Freedman**, Mgr., Chemical and Physical Laboratory; **E. C. Hughes, Jr.**, Mgr., Commercial Engineering; **R. L. Klem**, Mgr., Engineering Administration and Special Project Control; **C. T. Miller**, Mgr., Nuvisor Manufacturing; **G. M. Rose**, Mgr., Advanced Development; and **R. A. Wissolik**, Mgr., Test and Standards Engineering.

SURFCOM EXPANDS DATA TRANSMISSION ENGINEERING TO NEW YORK

The DEP Surface Communications Division has established a new Digital Data Communications Design Activity in New York. Located at 75 Varick St., the group is managed by **R. H. Fox**, and now comprises three Leaders and thirty engineers. The new activity is an extension of Data Communications Engineering, Camden, **R. L. Rocamora**, Manager, part of Digital Communications Equipment Engineering, **L. E. Mertens**, Manager. The New York group will be concerned with the product design of digital data-transmission devices such as modems, switchboards, maintenance and support equipment, and checkout equipment, and will be involved with projects for Minuteman, ComLogNet, and UniCom.—*C. W. Fields*

AED TO SIMULATE SPACE ENVIRONMENT IN NEW TEST FACILITY

A Space Environmental Center is now under construction at the Astro-Electronics Division near Princeton. This facility, involving 25,000 sq. feet of space with one high-bay room equipped with an overhead crane, will house AED's existing satellite testing equipment (vibration, vacuum, thermal, and magnetic simulation) and also several new units of large testing equipment capable of handling the larger payloads of the future.

This newer equipment will include a Vac-

uum Chamber having work space of 24 feet in diameter by 20 feet high with ability to evacuate to 5×10^{-6} mm-Hg, with a temperature range of -100°F to $+250^{\circ}\text{F}$. It will also include a vibration system of 28,000 lbs. peak force applied either underneath or to the side of the device under test and a walk-in thermal-humidity chamber 14 feet by 14 feet by 17 feet clear inside height, with -50°F to $+205^{\circ}\text{F}$ temperature range and 0.20 to 95 percent humidity capability.

The building for the new Environmental Center is scheduled for completion in the fall of 1961, and all equipment is to be in operation by the end of 1961.—*J. Cartwright*.

DR. SHAW, TUBE DIVISION CHIEF ENG'R, RETIRES AFTER DISTINGUISHED CAREER

Dr. G. R. Shaw, Chief Engineer of the RCA Electron Tube Division, has retired after a distinguished 40-year career, 31 of those with RCA. In addition to his achievements in engineering-management, Dr. Shaw has provided leadership in sponsoring and advancing professional activities for engineers and helped pioneer the creation of the RCA ENGINEER.

Dr. Shaw graduated from Washington and Lee University with AB and AM degrees, and received his Ph.D. from the University of Wisconsin in 1920. He was with the GE



Dr. G. R. Shaw

National Lamp Works at Cleveland from 1920 through 1929, when he joined the RCA Manufacturing Co. Radiation Division as head of the Chemical Section. Successively, he held positions as Manager of the Research and Engineering Dept., Manager of Harrison Engineering, and in 1945 became Chief Engineer of the RCA Electron Tube Division, a position he held until his retirement in December 1960.

Dr. Shaw, who has a number of patents to his credit, has been active in professional societies as a Member of the American Chemical Society and the American Physical Society, and was named a Fellow of the IRE in 1954. His honors include the *Coffin Award* while at GE, and the RCA Victor *Award of Merit* in 1950-51.

ALINA HONORED FOR AUTHORSHIP

In a nation-wide competition, **W. P. Alina**, a plating engineer in the Production Engineering Dept. of the RCA Semiconductor and Materials Division, Somerville, N. J., tied for second place with his paper, "Tin Plating of Transistor Shells." The competition was sponsored by *Products Finishing* magazine. Mr. Alina was awarded a certificate and a cash prize of \$125. He has been in the electroplating field since 1954. Since coming to RCA has been honored twice for achievements: in the first half of 1959, he came in second for important contributions to the Cost Reduction Program, and in the second half of 1959, he was the highest eligible award winner for important contributions to the Cost Reduction Program.—*H. Tipton*.

DEGREES GRANTED

P. M. Toscano, from the Airborne System Division, DEP, Camden, has received his MS in Electrical Engineering from Drexel Institute of Technology.

REGISTERED PROFESSIONAL ENGINEERS

C. R. Monro , IEP	Prof. Eng. 10782, N.J.
H. Levine , Tube	Prof. Eng. 11612, N.J.
E. F. Cahoon , DEP	Prof. Eng. 11509, N.J.
J. W. Donato , DEP	Prof. Eng. 7140E, Pa.

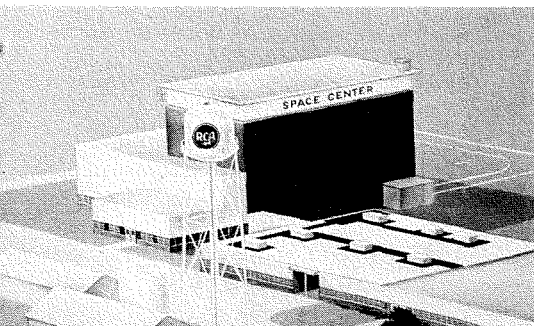

PROFESSIONAL ACTIVITIES

DEP-ASD; Camden: **P. M. Toscano** served as a rater at Session 3.2 (data handling) of MIL-E-CON, in Washington, D. C. **H. S. Dordick** served on the AIEE Papers and Meeting Committee, was local Arrangements Chairman for the Magnetic and Magnetic Amplifier Techniques Conference (AIEE/IRE), and is Chairman of the EIA National Committee TR-23 on Automatic Test Systems; in addition, Mr. Dordick has been appointed to the Staff of the Graduate School of Medicine, University of Pennsylvania, and holds an NIH grant to study ovarian functions by means of medical electronics; on Jan. 5, 1961 he lectured there on bio-instrumentation. **M. J. Ackerman** is Chairman of the IRE Subcommittee 25.10 on Oscillography, a Member of IRE Committee 25 on Measurements and Instrumentation, and a Member of AIEE Committee on Electronic and H-F Instruments.—*D. Dobson*

DEP-Applied Research: **Dr. J. Vollmer** was invited speaker on Jan. 10, 1961 (on "Plasma Physics") before the Physics Honor Society of St. Joseph's College. On Jan. 14, 1951, Dr. Vollmer delivered the first in a series of lectures for gifted science students sponsored by the Engineering and Technical Society Council of Delaware Valley; his topic was "What is Basic Science."—*F. W. Whittier*

RCA Victor Record Division, Indianapolis: **Dr. A. M. Max** has been invited to participate in the Gordon Research Conference, established by the AAAS, at Tilton, N. H., July 31 to Aug. 4, 1961. He will speak on "Stress in Electrodeposits." The Gordon Conference is a distinguished gathering of some 100 persons, by invitation, whose objective is to explore the limits of man's knowledge in science.—*M. L. Whitehurst*

RCA Staff, Product Engineering, Camden: **F. M. Oberlander**, Administrator, Materials Standards, has been named Chairman of the Working Group P7.1 on Hook-Up Wire of the Electronic Industries Association.

IEP, Camden: **J. C. Walter**, Mgr., High-Power Radar Engineering, is serving as Controls Counselor at the RCA Engineering Supervisory Development Program, conducted at Atlantic City.—*D. Kentner*

DEP-MECD, Burlington: At an RCA-Sponsored seminar, **Dr. E. Snitzer** of the American Optical Society spoke on "Fiber Optics." The MECD engineering staff and DEP Applied Research (Camden) were in attendance. Discussed were dielectric waveguides in the form of glass fibers, and glass-fiber mode selectors in optical masers.—*R. W. Jevon*

RCA Victor Ltd., Montreal: **Dr. F. G. Ross Warren**, Research Laboratories, was Chairman of the first session on "Devices" at the IRE Symposium on Communications, Montreal, Nov. 5, 1960. **Dr. M. P. Bachynski** (see article, this issue) spent six weeks in Europe during August and September 1960, attending a Plasma Physics Seminar at the Danish Atomic Energy Commission in Copenhagen, the General Assembly of URSI in London, as one of two Canadian delegates, and visited most of the prominent British laboratories engaged in plasma physics research.—*H. J. Russell*

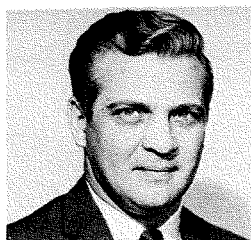

R. R. Hemp



J. L. Connors

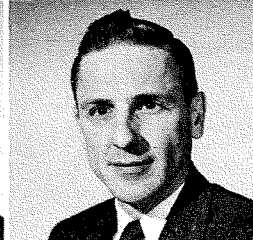

R. P. Dunphy

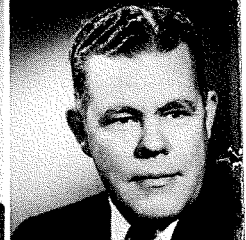

W. A. Howard

NEW ED REPS NAMED: HEMP FOR EDP COMMERCIAL SYSTEMS; CONNORS FOR ASD SYSTEMS ENGINEERING; DUNPHY FOR DEP CENTRAL ENGINEERING; HOWARD FOR NBC

In the continuing effort to maintain close and active contact with engineering groups, four new RCA ENGINEER Editorial Representatives have been named.

In the Electronic Data Processing Division of IEP, **R. R. Hemp** will fill the new Editorial Representative post for Commercial Systems Engineering. Mr. Hemp will serve on the RCA ENGINEER IEP Editorial Board, of which **S. F. Dierk**, Technical Publications Administrator for IEP, is Chairman.

In DEP, **J. L. Connors** has been named Editorial Representative for the Systems Engineering activity of the Airborne Systems Division, replacing **B. J. Goldstone**. In DEP Central Engineering, **R. P. Dunphy** has taken over as Editorial Representative for that group, replacing **H. L. Wuerffel**. Both will serve on the RCA ENGINEER DEP Editorial Board, of which **F. W. Whitmore**, Technical Publications Administrator for DEP, is Chairman. The Editors would like to extend their thanks to Messrs. Wuerffel and Goldstone.

At the National Broadcasting Company, Inc., N. Y., **W. A. Howard** has been named to the recently created post of Editorial Representative for NBC engineering activities.

Robert R. Hemp, Leader of the Commercial Systems Engineering Publications Group, joined the Engineering Department of the Electronic Data Processing Division in February, 1959. He participated in the installation of the first RCA 501 System. In 1960, he was promoted to Leader in the RCA 501 Engineering Evaluation Laboratory, where he was responsible for the operation and maintenance of the Laboratory System. Prior to his association with RCA, Mr. Hemp was employed by the IBM Corporation, where he worked on digital and analog bombing and navigation systems.

Joseph L. Connors received the BS (1950) and MS (1952) in Mathematics from Rutgers University. He continued studies in Electrical and Aeronautical Engineering at M.I.T. while working there at the Flight Control Laboratory. He joined the RCA Air-

borne Systems Laboratory at Waltham, Mass. in 1955, where he worked in fire-control systems. In 1958, Mr. Connors transferred to ASD Camden as a Project Leader responsible for the theoretical systems analysis of underwater sound systems. He is a member of the Mathematical Association of America and the Society for Industrial and Applied Mathematics.

Richard P. Dunphy, graduated from the Michigan College of Mining and Technology in 1941 with a BS in Metallurgical Engineering. After being Assistant Chief Metallurgist at the Symington-Gould Co., Rochester, New York, he spent 12 years on the research staff of the Naval Research Laboratory, Washington, D. C. Joining RCA in 1955, Mr. Dunphy has been Leader, Materials Standards, and Manager of Mechanical Standards and Environmental Engineering, and is presently Manager of Design Standards in DEP Central Engineering. Mr. Dunphy has been active in the Electronic Equipment Specifications Committee of the Aerospace Industries Association and its Drafting Panel. He is a registered Professional Engineer in the District of Columbia.

William A. Howard graduated from Howard Payne College in 1939 with a BA degree in Mathematics and Science and completed graduate work at Baylor University 1940-42. Mr. Howard, who has 15 years RCA engineering experience, was Mathematics and Physics instructor, and Senior Engineer at Philco for development work on "Block" Television Airborne equipment for the Army and Navy prior to joining RCA-NBC Labs in 1946. Mr. Howard is widely known in Broadcast engineering circles both for his development engineering work at NBC and his Technical Operations Supervisory Work at NBC Stations WNBK, WTAM, WRCV and WRC-TV. Mr. Howard is presently Manager of Engineering Standards and Practices, NBC, New York City. He is a member of SMPTE, AIEE, Senior Member of IRE, and Secretary of the New York IRE Professional Group for Engineering Writing and Speech.

ENGINEERING MEETINGS

April 4-6: International Symposium on Electromagnetics & Fluid Dynamics of Gaseous Plasma, Auditorium of Engineering Society Bldg. Polytechnic Institute of Brooklyn, 33 W. 39th St., New York.

April 5-7: Annual Convention, Institute of Environmental Sciences, Hotel Park-Sheraton, Washington, D. C.

April 5-7: Symposium on Materials & Electron Device Processing, ASTM Committee F-1 on Materials for Electron Tubes & Semiconductor Devices, Franklin Institute, Philadelphia.

April 19-21: Southwestern IRE Conference and Electronic Show (SWIRECO), Dallas Memorial Auditorium and Baker Hotel, Dallas, Texas.

May 7-11: 39th Annual Convention & Broadcast Engineering Conference, NAB, Shoreham and Sheraton-Park Hotel, Washington, D. C.

May 8-9: 5th Midwest Symposium on Circuit Theory, Allerton Park and Urbana Campus, University of Illinois.

May 8-10: National Aeronautical Electronics Conference (NAECON), Miami and Dayton Biltmore Hotels, Dayton, Ohio.

May 9-11: Electronic Components Conference, San Francisco, Calif.

May 9-11: Western Joint Computer Conference, Ambassador Hotel, Los Angeles, California.

May 15-17: Microwave Theory & Techniques National Symposium, IRE, Sheraton Park Hotel, Washington, D. C.

May 22-24: 5th Global Communications Symposium (GLOBCOM V), Sherman Hotel, Chicago, Illinois.

May 23-25: Symposium on Large-Capacity Memory Techniques for Computing Systems, ONR, Dept. of Interior Auditorium, Washington, D. C.

Editorial Representatives

DEFENSE ELECTRONIC PRODUCTS

F. D. WHITMORE, *Chairman, Editorial Board*

Editorial Representatives

- JOHN BIEWENER, *Airborne Systems Division, Camden, N. J.*
R. D. CRAWFORD, *Design Development Engineering, Airborne Systems Division, Camden, N. J.*
D. B. DOBSON, *Systems Support Engineering, Airborne Systems Division, Camden, N. J.*
J. L. CONNORS, *Systems Engineering, Airborne Systems Division, Camden, N. J.*
I. N. BROWN, *Missile and Surface Radar Division, Moorestown, N. J.*
D. J. ODA, *West Coast Missile and Surface Radar Division, Van Nuys, Calif.*
R. W. JEVON, *Missile Electronics and Controls Division, Burlington, Mass.*
R. E. PATTERSON, *Surface Communications Division, Camden, N. J.*
L. A. THOMAS, *Astro-Electronics Division, Princeton, N. J.*
F. W. WHITTIER, *Applied Research, Defense Engineering, Camden, N. J.*
R. P. DUNPHY, *Central Engineering, Defense Engineering, Camden, N. J.*

INDUSTRIAL ELECTRONIC PRODUCTS

S. F. DIERK, *Chairman, Editorial Board*

Editorial Representatives

- C. E. HITTLE, *Closed Circuit TV and Film Recording Department, Broadcast and TV Equipment Division, Hollywood, Calif.*
C. D. KENTNER, *Broadcast Transmitter and Antenna Engineering, Broadcast and TV Equipment Division, Camden, N. J.*
J. H. ROE, *Broadcast Studio Engineering, Broadcast and TV Equipment Division, Camden, N. J.*
N. C. COLBY, *Communications Products Department, Communications and Controls Division, Canonsburg, Pa.*
J. J. HOEHN, *Industrial Controls, Communications and Controls Division, Camden, N. J.*
J. E. VOLKMANN, *Audio Products Engineering, Communications and Controls Division, Camden, N. J.*
R. R. HEMP, *Commercial Systems Department, Electronic Data Processing Division, Camden, N. J.*
M. C. KIDD, *Industrial Computer Systems Department, Electronic Data Processing Division, Natick, Mass.*
T. T. PATTERSON, *Data Communications and Custom Projects Department, Electronic Data Processing Division, Cherry Hill, N. J.*
J. H. SWEER, *Advanced Systems Development Engineering, Electronic Data Processing Division, Cherry Hill, N. J.*
W. C. JACKSON, *RCA Communications, Inc. New York, N. Y.*

RCA VICTOR COMPANY, LTD.

H. J. RUSSELL, *Research and Engineering, Montreal, Canada*

The Editorial Representative in your group is the one you should contact in scheduling technical papers and announcements of your professional activities.

RCA ELECTRON TUBE AND SEMICONDUCTOR & MATERIALS DIVISIONS

J. F. HIRLINGER, *Chairman, Editorial Board*

Editorial Representatives, RCA Electron Tube Division

- W. G. FAHNESTOCK, *Conversion Tube Operations, Lancaster, Pa.*
J. H. LIPSCOMBE, *Black & White Kinescopes, Marion, Ind.*
J. D. ASHWORTH, *Entertainment Tube Products, Lancaster, Pa.*
R. J. MASON, *Receiving Tubes, Cincinnati, Ohio*
T. M. CUNNINGHAM, *Entertainment Tube Products, Harrison, N. J.*
J. KOFF, *Receiving Tubes, Woodbridge, N. J.*
H. S. LOVATT, *Power Tube Operations and Operations Services, Lancaster, Pa.*
F. H. RICKS, *Receiving Tubes, Indianapolis, Ind.*
H. J. WOLKSTEIN, *Industrial Tube Products, Harrison, N. J.*

Editorial Representatives, RCA Semiconductor & Materials Division

- E. I. SMALL, *Needham Materials Operation, Needham, Mass.*
RHYS SAMUEL, *Microelectronics, Somerville, N. J.*
HOBART TIPTON, *Semiconductor Devices, Somerville, N. J.*
J. D. YOUNG, *Findlay, Ohio*

RCA VICTOR HOME INSTRUMENTS

K. A. CHITTICK, *Chairman, Editorial Board*

Editorial Representatives

- D. J. CARLSON, *Advanced Development Engineering, Cherry Hill, N. J.*
E. J. EVANS, *Resident Engineering, Bloomington, Ind.*
F. T. KAY, *TV Product Engineering, Cherry Hill, N. J.*
J. OSMAN, *Resident Engineering, Indianapolis, Ind.*
W. S. SKIDMORE, *Radio "Victrola" Product Engineering, Cherry Hill, N. J.*

RCA SERVICE COMPANY

- W. W. COOK, *Consumer Products Service Department, Cherry Hill, N. J.*
M. W. TILDEN, *Government Service Department, Cherry Hill, N. J.*
E. STANKO, *Technical Products Service Department, Cherry Hill, N. J.*
J. J. LAWLER, *Electronic Data Processing Service Department, Cherry Hill, N. J.*

RCA LABORATORIES

E. T. DICKEY, *Research, Princeton, N. J.*

RCA VICTOR RECORD DIVISION

M. L. WHITEHURST, *Record Engineering, Indianapolis, Ind.*

NATIONAL BROADCASTING COMPANY, INC.

W. A. HOWARD, *Staff Engineering, New York, N. Y.*