

**ENGINEERS ARE DIFFERENT**—History has finally rewarded the engineer with the long-overdue respect of a society in urgent need of his talents. After a generation or more as the Ugly Duckling in the family of professions, engineering has matured virtually overnight into a most handsome Swan. Many familiar elements have gone into this happy transformation, all of them reflecting the new importance of technology as the foundation and shield of our civilization in this second half of the twentieth century.

There can be no disputing the justice of this public promotion for the professional engineer after too many years of public neglect. But honor overdue may be a heady wine. For the engineer today, the premium newly placed upon his technical abilities may obscure his appreciation of the unique social and political responsibilities stamped upon the other side of the coin.

“Engineer” is not a job classification applicable during only forty hours or so each week. It is a professional title, signifying certain vital attributes of education and experience carried at all times by its possessor wherever he goes.

# Fourth Anniversary

These attributes have particular importance in a society that must give increasing consideration to technology in the formulation of public policy relating to economics, education, and defense. In this circumstance, the citizen must turn for guidance to those with special knowledge of technical matters, just as he turns to the medical specialist in matters of public health or to the lawyer in matters of legislation. Viewed from this angle, engineers are different—the difference consisting in an ability to interpret science and technology to their fellow citizens.

This task of interpretation is performed not only in the laboratory or the plant, but in the community as well. As a citizen, the engineer shares with all others a concern in the public policies of the community, the state, and the nation. As a specialist in technology, he is in a position to contribute essential guidance and counsel on those increasingly frequent occasions when such policies are influenced by technological advance. The most common examples lie in the field of community action relating to such matters as the curricula and equipment of local schools, problems of traffic control, expenditures for police and fire department communications systems, civil defense programs, and the like.

Participation in the affairs of the community has thus become an obligation upon the professional engineer. Accustomed in the past to sharing his knowledge largely with his colleagues in the profession, he has the new responsibility today of sharing it with all of his fellow citizens as a matter of urgent public interest. The community, in its turn, has learned to listen with respectful attention to what its engineering members have to say. The obligation is thus accompanied today by a clear opportunity.

Never has the time been so ripe for the engineer to serve his community, his great profession, and himself by the public exercise of those special talents that qualify him as a professional man.



*Douglas H. Ewing*  
DOUGLAS H. EWING, Vice President  
Research and Engineering,  
Radio Corporation of America.

## CONTENTS

Cost Consciousness in DEP Engineering .....	E. F. Bailey	2
Some New Processes and Techniques for Electron-Tube Fabrication .....	W. T. Dyall	4
Modern Insulation Concepts .....	Siegmund Halpern	8
RCA 501 High-Speed Printers—The Story of a Product Design .....	C. C. Eckel and D. Flechtner	11
Color Television Receivers .....	A. J. Torre	14
RCA Electronics Guide Two New Moore-MacCormack Liners .....	I. F. Byrnes	19
Page-RCA Pacific Scatter Communications System .....	R. W. Conner, R. S. Lawton, and M. C. Myers	24
Synthesis of Automatic Flight Control Systems .....	Dr. C. W. Steeg and F. A. Barnes	28
A 17" Portable TV Receiver with Remote Control .....	R. J. Lewis	33
A Breakthrough in Science Education .....	R. J. Hall	36
New Diode-Triode Transistor for Detector-Driver Service .....	Derek Thorne and R. V. Fournier	38
Integrated Semiconductor Devices ..	J. T. Wallmark and S. M. Marcus	42
Tubes and Transistors in Non-Entertainment-Type Equipment ..	G. G. Carne, D. P. Heacock, R. B. Janes, and R. L. Kelly	46
Military Operations Research .....	M. E. Hawley	50
Package Engineering and Its Relation To Product Design .....	I. M. Rehm	52
Patents Granted to RCA Engineers .....		55
Pen & Podium .....		56
Engineering News and Highlights .....		58

VOL. 5, NO. 1 • JUNE-JULY, 1959

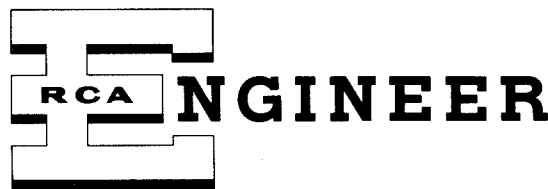

### Editorial Advisory Board

E. I. Anderson, Chief Engineer,  
Home Instruments Division

M. C. Batsel, Chief Technical Administrator  
Defense Electronic Products

J. J. Brant, Director, Personnel

C. C. Foster, Mgr. RCA REVIEW

M. G. Gander, Mgr. Engineering,  
RCA Service Co.

Dr. A. M. Glover, Vice President,  
Semiconductor and Materials Division

C. A. Gunther, Chief Defense Engineer,  
Defense Electronic Products

J. Haber, Director, Community Relations

D. P. Heacock, Administrative  
Engineer, Product Engineering

W. C. Morrison, Mgr. Engineering  
Plans & Services, Industrial Electronic Products

J. C. Rankin, Mgr., General Employment

H. E. Roys, Mgr., Engineering,  
RCA Victor Record Division

D. F. Schmit, Vice Pres., Product Engineering

Dr. G. R. Shaw, Chief Engineer,  
Electron Tube Division

S. Sternberg, Chief Engineer,  
Astro Electronic Products Div.

### "RCA Engineer" Staff

W. O. Hadlock, Editor

R. J. Hall, Assistant Editor

Miss E. R. Kraus,  
Editorial Secretary

J. L. Parvin, Art and Production

J. O. Gaynor, Photography

*Engineering Editors*

P. R. Bennett, Mgr., Advanced  
Development Engineering  
RCA Victor Radio & 'Victrola' Div.

R. S. Burnap, Mgr., Commercial  
Engineering,  
Electron Tube Division

C. A. Meyer, Mgr., Commercial  
Engineering Technical Services,  
Electron Tube Division

C. W. Sall, Engineering Editor,  
Industrial Electronic Products

C. M. Sinnett, Mgr., Advanced  
Development Engineering,  
RCA Victor Television Division

F. D. Whitmore, Engineering  
Editor,  
Defense Electronic Products

Copyright 1959  
Radio Corporation  
of America  
All Rights Reserved

PRINTED  
IN  
U.S.A.

# COST CONSCIOUSNESS IN DEP ENGINEERING

"COST CONSCIOUSNESS" is given different emphasis by engineers in the various divisions of RCA. Engineers designing home TV receivers, mass-production tubes, or home stereophonic instruments have gained much valuable experience in such efforts. They have their own familiar standards of cost consciousness in keeping the selling price at an acceptable level.

In Defense Electronic Products, cost reduction efforts are somewhat similar. Yet they are different too, because work is extended to include effects of a design on the cost of maintaining and operating equipment in the field. Another important consideration for DEP is the shortage of manpower when national emergencies occur. This problem is directly related to lowering of equipment costs since every \$5.00 reduction in cost saves approximately one man-hour in production. Even today this factor is an important consideration because of the current shortage of skilled manpower necessary to design and produce complex military equipment.

Recognizing these problems, the Military Agencies established a program called "Value Engineering." They defined it as "An objective appraisal of all elements of the design, construction, procurement, installation and maintenance of an equipment, including the applicable equipment specifications, in order to achieve necessary functions, maintainability and reliability of an equipment at minimum cost."

In implementing this program the military has assumed that the contractor's design engineers are mainly responsible for (1) performance of equipment to meet specifications, and (2) meeting the schedules established.

By **E. F. BAILEY, Administrator**  
*Value Engineering*  
*Defense Electronics Products*  
*Camden, N. J.*

This, then, means that special attention must be given by the contractor to these questions: (1) are specifications realistic? (2) were reliability and maintainability considered? and (3) does design recognize the most inexpensive way of achieving performance and reliability?

## WHAT IS RCA DOING TO ACCEPT THIS CHALLENGE?

Knowing the importance of the Military Program, DEP established its own Value Engineering program to not only decrease the design costs and selling price, but to complement the military in its programs. The cooperative nature of the two programs is shown in Fig. 1. It can readily be seen that there are two distinct efforts, (1) Value Engineering of systems or specifications and planning and (2) Value Engineering of design.

To accomplish this, DEP formed a functional organization headed by the Administrator, Value Engineering, reporting to the Chief Defense Engineer. His counterpart exists in each of the departments of DEP. These men meet periodically as a "Value Improvement" Council to discuss needs for carrying out the program. DEP's major objectives are to establish programs designed to further: (1) cooperation with Military Value Engineers on critiquing specifications, (2) Reliability and Maintainability considerations, (3) efficiency of Design Reviews, (4) review of prior

production and preproduction models and drawings for more competitive production bidding (second-look approach), and (5) training.

The special attention prescribed above is needed to bring cost considerations into proper perspective through both the early planning and in the design cycle. Therefore, the efforts of Value Engineering tie in with the basic cost work and planning of the project, and with the design engineers responsible for the system equipment.

## ARE SPECIFICATIONS REALISTIC?

Of the objectives listed by DEP and the Military for special attention, the most important value-wise is, "Are the specifications realistic?" This is the question that gives the greatest return to the customer and involves close Engineering, Marketing, and Customer relationships.

It is obvious that specifications not only influence the performance attributes of an equipment but also maintenance, reliability, tactical availability, production rate, and rapidity of obsolescence. If specifications are not realistic, costs skyrocket; then value becomes nil.

The major step to overcome the problem of unrealistic specifications is to sell not only a product, but service as well. That is: (1) get the customer to accept the philosophy that a contractor, designing and building his equipment, is not just a vendor but part of his team, and (2) that the contractor is genuinely interested in the management of this equipment after it is procured. Once these attitudes have been adopted, a better picture of field usage, maintenance, and total quantity to be pur-

VALUE ENGINEERING IN DEVELOPMENT CONTRACTS

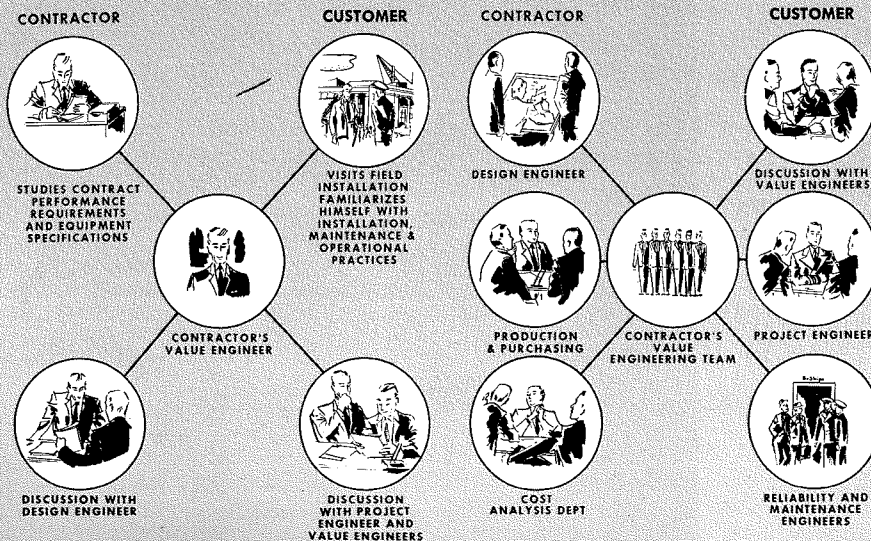

chased, will be gained. The engineer will now have more realistic specifications upon which to build his design.

#### RELIABILITY AND MAINTENANCE

Another major objective listed for special attention concerns *reliability and maintenance*. Although closely tied in with specifications, these are being emphasized again because of cost considerations. The military has stated that the money usually required to maintain an equipment is ten times the amount needed to procure it. Thus, from an ideal cost consciousness standpoint, the customer would be much better off to increase the equipment procurement cost when it results in greater reduction in his maintenance costs.

Reliability, referred to here, is the ability to predict the period between failures. It is part of the overall maintenance cost and planning. The length of this period depends on the simplicity of design as well as the quality of parts used. Both of these are directly related to the specifications which stipulate only the essential functions and environmental conditions.

The cost of reliability should be determined by a "trade-off" or compromise between procurement and maintenance costs. The proper trade-off with maintenance cost must be reached and understood by both the contractor and the customer. This can best be determined by the team philosophy. Certainly, the customers' support and equipment maintenance philosophy must be sought from the beginning so the customers will be prepared for the maintenance concept incorporated in the final design. This is a responsibility that must be diligently accepted by the contractor. For example, the increases in design and procurement costs from introducing such techniques as marginal testing and modular construction would be worthless and wasteful if the customers' support policies were not altered to conform with such techniques.

#### DOES THE DESIGN RECOGNIZE THE MOST INEXPENSIVE WAY OF DOING THE JOB?

This is the cost consciousness area which usually receives the greatest publicity and effort. This is true because it is possible to measure the cost savings of the program with "before-and-after" comparisons. In addition, this is the area in which the contractor can exercise the most control within his organization, and directly affect his profit and competitive picture. Special attention is necessary when the design engineer is faced with short-time schedules to design which pushes ahead the state of the art.



**E. F. BAILEY** graduated from the University of Notre Dame in 1948 with a B.S. Degree in Metallurgy. He received his M.S. in Metallurgy in 1949 from Notre Dame. Following this, he joined the Naval Research Laboratory as a scientist primarily involved in the metallurgical effects caused by mill processing, heat treating, forming, welding on the mechanical properties of materials and structures.

In 1953 he joined the Metlab Co., a commercial heat treating firm, where he was assistant to the President, responsible in increasing the metallurgical capabilities of the company to cope with modern techniques and to further business expansion.

In April 1954 he joined RCA to work on metallurgical problems both in engineering and production. In 1955 he rose to Manager, Mechanical and Materials Engineering in Central Services and Engineering, and then to Manager, Technical Administration and Coordination, Airborne Systems Department. Presently he is Administrator, Value Improvement Program, for DEP.

He is a member of ASM, AWS and represents the company on various industrial committees.

#### DESIGN REVIEWS

Design review programs parallel reliability programs. At three stages during the design of an equipment, the design is reviewed for performance, reliability, and cost-to-manufacture. At present, *performance and reliability goals* are established for each equipment. In the near future, cost-goals based on estimated production quantities will be added. Then, important trade-off between operational costs (reliability and maintainability) and procurement costs related to design will have fuller considerations. Objectives of these reviews are (1) design must meet requirements of performance specification, (2) predicted reliability must be above minimum goal, (3) assure a maximum use of standard parts, (4) determine where costs can be reduced and (5) provide for minimum field-use cost. A recent result in Missile and Surface Radar is indicative of the effectiveness of design reviews that occur during the progress of a design. Unrealistic specifications and a lack of standardization became apparent from reviews of transistor circuits. Further studies saved \$235,000.

#### A "SECOND LOOK" AT COSTS

Prior and pre-production models plus finished equipments are the easiest to measure since either prior production costs and/or cost estimates exist. Such

reviews are usually done on equipments of highly competitive nature. To make this review, a team is appointed from Engineering, Purchasing, and Manufacturing. Their sole purpose is to increase the equipment value through design changes that reduce purchasing and manufacturing costs without impairing essential performance and reliability. This group reviews the models, drawings, cost estimates, and actual costs to determine the most fruitful areas for intense study. In general, the following questions form the basic chronological guide lines in this study: (1) what is it? (2) what does it do? (3) what does it cost? (4) what else will do the job? (5) what does it cost? (6) evaluate and decide.

A rule of thumb used for evaluation of a proposed change is: Savings based on production quantity should be approximately ten times the cost of making the change (tests, ECN, tools, etc.) This ratio can be raised or lowered according to the competitive picture.

During the past eighteen months, several equipments were studied on a "second-look" basis. Typical of the results achieved are:

	Ratio Savings/Change Cost	% Savings Equip. Cost
AIC-10	13-1	19%
GRC-50	12-1	18%
GKA-5	45-1	20%
ARR-48 Receiver	30-1	25%

#### VALUE IMPROVEMENT WORKSHOP

Two training sessions for engineers, known as Value Improvement Workshop, have been held. The object of these courses is to train engineers in the techniques of critiquing a design, either their own or others'. These are essentially laboratory courses which are approximately 30% lectures in the disciplines or techniques of value engineering. The other 70% is spent actually working with existing designs and models with the express purpose of reducing the cost without impairing performance, reliability, or maintainability. The cost savings resulting from the workshops are in line with the results on equipments given in this paper.

#### CONCLUSION

Summarizing, cost consciousness is a necessary thing. It saves vital man hours, retards inflation and high costs, and increases the business health of the firm for which you work. Designing something that performs acceptably provides great satisfaction; but designing something that performs acceptably at the lowest possible manufacturing cost is a far greater challenge. DEP's Value Engineering is the *key* to this challenge.



# SOME NEW PROCESSES AND TECHNIQUES FOR ELECTRON-TUBE FABRICATION

CONTINUED IMPROVEMENT in the performance capabilities of electron tubes depends upon continued advancement in the processes and techniques of tube fabrication, as well as on the improvement of designs and materials. This paper describes some of the recent developments in tube fabrication processes and techniques which have made possible the improvement of tube performance characteristics and/or reductions in the cost of tube fabrication.

## ULTRASONIC CLEANING

During the past few years, the use of ultrasonic energy in the fabrication of electron tubes has spread rapidly. Ultrasonic energy is a vibrational energy generated at a frequency higher than the audible frequency range. "Ultrasonic" is to be distinguished from "supersonic" since the latter term refers to a velocity greater than the velocity of sound, and does not refer to vibrational frequency. Therefore, interchangeable use of these two terms is to be deprecated.

Ultrasonic cleaning is a process by which physically adherent contaminants are removed from surfaces by immersion in a suitable liquid agitated by ultrasonic vibrations. The liquid generally used is a weak solution of a detergent.

Ultrasonic cleaning equipment comprises a radio-frequency oscillator, a transducer, and a vessel for containing a cleaning solution. The output of the oscillator, at a frequency of about 20 kilocycles, is applied to either a magnetostrictive or piezoelectric-type transducer. The transducer converts the electrical oscillations to mechanical vibrations which in turn produce a sound wave, i.e. a longitudinal wave of successive compressions and rarefactions. In liquids generally used for this purpose, a wavelength of about 7.5 centimeters is produced. At this relatively long wavelength, the sound waves are easily diffracted around intricate shapes, and, furthermore, the relatively low frequency produces a large particle displacement in the liquid so that the efficacy of contam-

inant removal from intricate shapes is enhanced.

The power input to the transducer is large enough so that pressure in the rarefaction of the sound wave produced in the liquid is below the vapor pressure of the liquid. When this low pressure is achieved, the liquid vaporizes locally and fractures into thousands of tiny bubbles. The bubbles thus formed soon break, many of them against surfaces which are immersed in the liquid. This phenomenon, called cavitation, has long been recognized as a serious problem in the design of ship propellers, turbine blades, and pumps. Although the forces involved in ultrasonic cleaning are considerably smaller than those acting on propellers, they are sufficient to remove physically adherent contaminants. The power requirements are small because, in most liquids, cavitation can be achieved by an input of approximately 0.6 watt per square centimeter of transducer surface area.

In the design of an ultrasonic cleaning tank, any of several shapes of transducers may be considered, as shown in Fig. 1. The use of planar transducers is required when a uniform distribution of energy throughout the volume of the cleaning tank is desired. The transducers are usually placed on the bottom and/or sides of the tank. In some cases, the use of a cylindrical or spherical segment of

a transducer is desirable to produce a focusing action. The use of such curvilinear transducers causes the concentration of energy at the center of curvature for a spherical segment and along the axis in the case of a cylindrical segment.

The use of ultrasonic cleaning is most beneficial in the case of parts which have small crevices, cavities, or re-entrants because the cavitation produces a scrubbing action and because the sound waves effectively remove air bubbles and thereby allow improved penetration by the detergent. The cathode cup shown in Fig. 2, which is of the type used in many cathode-ray tubes, is an example of a part for which ultrasonic cleaning is ideal. Ultrasonics are also especially helpful in cleaning glass parts.

Because the success of ultrasonic cleaning depends upon cavitation, it is important to determine whether the equipment is satisfactorily creating sound waves in the liquid. A simple test, which is often sufficient, consists of placing a small strip of aluminum foil in the liquid in the cleaning tank. The foil will be pitted by the cavitation action in a few seconds if the power delivered by the transducer is normal. Thus, the condition of the equipment can be qualitatively related to the time required for the aluminum to become pitted. The author is not acquainted with any method of measurement which will give quantitative results proportional to the "cleaning power." A measuring instrument, which will measure the force produced on a given surface by the breaking of the bubbles which result from cavitation, is needed.

by  
**WILLIAM T. DYALL, Mgr.**  
*Conversion Tube Shop  
Electron Tube Division  
Lancaster, Pa.*

Fig. 1.—Two types of transducers, the cylindrical-spherical and the planar-cubical, produce focused energy and uniform energy respectively.

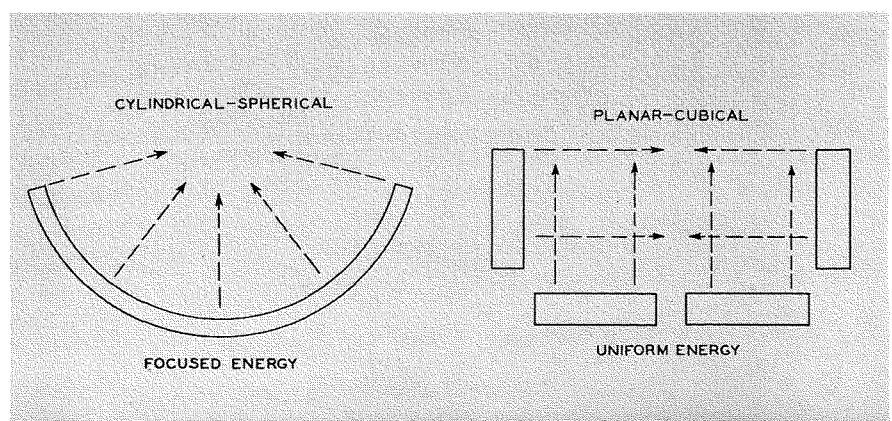

### CATHODE CUP

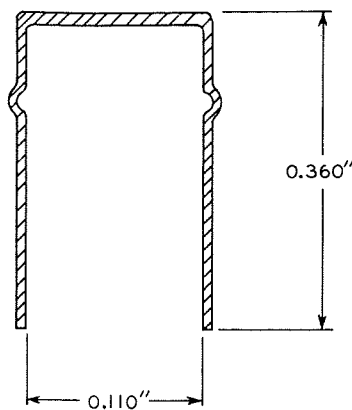

Fig. 2—Sketch of a cathode cup, example of a part requiring ultrasonic cleaning.

### ULTRASONIC GRINDING

Another new tube fabrication process is ultrasonic grinding, a process used for cutting hard or brittle materials. An ultrasonic grinding machine comprises a radio-frequency generator, having a typical output of 700 watts at 25 kilocycles, which drives a magnetostrictive transducer. A schematic of an ultrasonic grinder is shown in Fig. 3. The transducer, which is made of laminated nickel, is mounted on a mechanically resonant structure, and supports the tool holder and the cutting tool itself. The tool holder is shaped to act as a velocity transformer or acoustical-impedance matching device. During operation, the amplitude of vibration of the transducer is only about 0.0002-inch, while the amplitude of vibration of the tool is about 0.002-inch.

During the actual cutting operation, the work piece is secured on the horizontal bed of the machine and covered with an abrasive slurry. The tool is lowered into the slurry until it almost touches the work piece. The rapid motion of the tool in the vertical direction imparts energy to the abrasive slurry particles so that they move rapidly and impinge on the work piece to produce a slight erosion. As the process continues, the work piece is eroded in a pattern which corresponds closely to the shape of the tool.

This technique is limited to brittle materials and cannot be successfully applied to very soft or tough surfaces. The tool, therefore, should be made of materials which are tough but not brittle, to prolong its useful

life. Typical of the materials which have been cut successfully by this method are glass, ceramics, silicon, germanium and tungsten carbide.

Ultrasonic grinding offers considerable flexibility because, within certain size limitations, it can be used to cut any random shape. The smallest size hole which can be drilled by this method is limited because penetration of the tool into the body of the material tends to prevent the passage of the abrasive slurry around the tool and into the hole. It is possible, therefore, to drill a smaller hole in a thinner piece of material. A hole as small as 0.014-inch in diameter can be drilled in material  $\frac{1}{16}$ -inch thick in about five minutes. The largest size cut that can be made is limited by the diameter of the tool holder, in a typical equipment, to about two inches over-all because a tool larger than the diameter of the tool holder will exhibit nodes and anti-nodes along its horizontal dimensions. If tolerances are not too exacting, however, it is possible to produce a larger pattern by a step-and-repeat process.

Fig. 4 illustrates several pieces of different size which were cut by ultrasonic grinding. Fig. 4a shows thirty holes, each 0.020-inch in diameter, cut in one operation through a 0.030-inch-thick ceramic or glass dynode support in about thirty minutes. Fig. 4b shows a hole of 0.312-inch diameter cut in  $\frac{3}{4}$ -inch-thick glass in forty minutes. Fig. 4c illustrates a 1.5-inch hole cut in an alamanox ceramic 0.150-inch thick in about two hours.

From Fig. 4, it can be seen that this method is time consuming and, therefore, expensive. For factory production purposes, other processes of shaping brittle materials are faster, cheaper, and just as accurate if not more accurate. The important advantage of ultrasonic grinding is the flexibility which it provides for experimental work. If a few pieces of an unusual configuration in glass or ceramic are needed, the required tool can be made quickly and a few parts turned out immediately. In this case, ultrasonic grinding is much faster and less costly than the more conventional pressing and molding techniques.

### ULTRASONIC WELDING

Ultrasonic welding is a method of joining metals by a cold diffusion process. The actual physical process of joining the metals is very similar to that of the familiar cold pinch-off technique. Although deformation results at the inner surfaces of the two metals being ultrasonically welded, the amount of deformation on the outer surfaces is very small. There is no weld splash and, of course, no oxidation because there is no heat. The diffusion process is a process of molecular transference or plastic flow. The two pieces of metal to be joined are clamped together under a suitable transducer, and ultrasonic vibrations are applied at right angles to the direction of the clamping force to produce the jointure.

In addition to the advantages of elimination of splash, reduction of mechanical deformation, and elimination of oxidation, ultrasonic welding also provides a means for joining many metals such as copper, aluminum, silver, molybdenum, and tungsten which cannot be conveniently welded by conventional techniques. Thus, ultrasonic welding has opened up possibilities for the use of new materials in the design of electron tubes.

### ULTRASONIC DEBURRING

Limited success has been obtained in the deburring of metal parts by the use of ultrasonic energy. Small, lightweight parts are especially good candidates for this process. Parts to be ultrasonically deburred are placed in a beaker which contains an abrasive mixture, typically 80-mesh grit and detergent in water. The beaker is placed at the point of maximum agitation in an ultrasonic

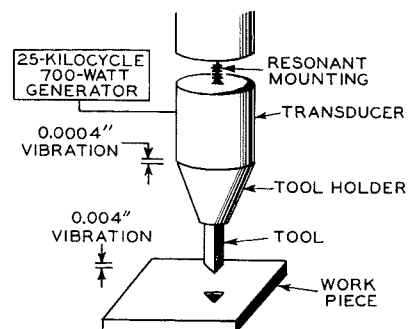

Fig. 3—Schematic of an ultrasonic grinder.

cleaning tank filled to the usual level with water. Parts have been satisfactorily deburred by this method in four hours as contrasted to 48 hours in conventional tumbling equipment.

#### ELECTRICAL-DISCHARGE MACHINING

Electrical-discharge machining is a metal-cutting process by which metal is removed by the eroding action of an electric spark. In this process, a pulsed potential is applied between the cutting tool and the work piece. As the potential on the tool becomes more and more negative with respect to the work piece, a potential is reached at which an electrical discharge between tool and work takes place. The action of this discharge or spark is to remove a small amount of metal from the work piece. One theory is that the high charge involved creates large coulomb forces which literally tear chunks of the metal away. To concentrate the spark, to cool the tool and the work, and to prevent oxidation, the part being machined is covered with oil.

Like ultrasonic grinding, electrical-discharge machining can be used to cut arbitrary configurations. Unlike the ultrasonic process, however, the spark method is an economical method, and, in fact, may be the only method of achieving certain desired results.

Electrical discharge machining can only be used for cutting conductive materials such as carbides, tungsten, tool steel, cermets, molybdenum, germanium, cobalt, nickel, titanium and copper. Tolerances of  $\pm 0.001$ -inch can be achieved practically in production, and somewhat smaller tolerances can be achieved in experimental work.

#### PHOTO-ETCHING

Photo-etching is a low-cost process which combines photographic processing and acid etching to produce metal parts of intricate design to close dimensional tolerances. This process, often called chemical milling, has been used for several years to produce shadow masks for color kinescopes. Less well known is the fact that this process provides a means for making developmental parts by the use of very simple equipment involving very low setup costs and short lead time. It is especially suited to



**W. T. DYALL** received the B.S. degree in Physics in 1943 from Iowa Wesleyan College and the M.S. degree in Physics in 1948 from the Massachusetts Institute of Technology. From 1943 to 1946, he served in the United States Navy as an Electronics Officer in both Atlantic and Pacific Ocean areas. In 1948 he joined the RCA Electron Tube Division in Lancaster, Pa., as a Design and Development Engineer, and was assigned to work on the design of pickup and storage tubes and equipment. In 1951 he became an Engineering Leader in charge of the same type of activity. In 1952 he was transferred to the Tube Development Shop as Supervising Engineer. In 1955 he was appointed to his present position, Manager, Conversion Tube Development Shop.

Mr. Dyall is a member of the American Physical Society and a Senior member of the Institute of Radio Engineers, and served as Chairman of the Lancaster Subsection of the IRE for the 1955-56 season.

producing planar metal parts containing complex hole shapes.

An accurate large-scale drawing of the part is made and photographically reduced to the proper size for the finished part. The negative of the reduced photograph is then used to make a contact print on the metal surface which has been coated with a commercial photoresist. After the contact exposure, the resist is developed, and, finally, the etching process removes all of the metal which is no longer protected by the resist covering. This process is currently used, for example, to provide masks for the evaporation of metals. A typical mask is shown in Fig. 5. Metals which can be etched by this method include copper, super nickel, nickel, stainless steels, iron, cold rolled steel, aluminum, and chromium. Tolerances of  $\pm 0.001$ -inch can be reproduced in material up to 0.005-inch thick. The thickness of the material is

limited to about 0.010-inch as a practical matter.

#### HIGH TEMPERATURE BRAZING

A method of brazing at temperatures above 1900 degrees Centigrade has been developed for application to tube assemblies which must operate at very high temperatures. This high-temperature-brazing technique is particularly useful in making cathode assemblies because tungsten or molybdenum parts can be joined by high-temperature brazing instead of by crimping or by other mechanical fastening methods. Accurate jiggling of an assembly is preserved during brazing, and shifting of parts during tube operation is minimized (especially in comparison to a clamped assembly). The work is heated in a forming gas atmosphere by electrical current, and the temperature is measured by an optical pyrometer. Conversion tables are used to relate the brightness temperature as measured

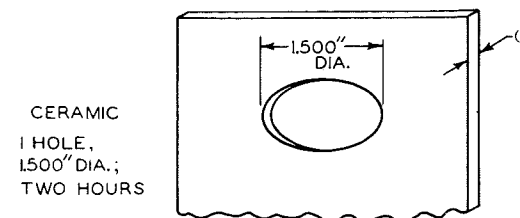
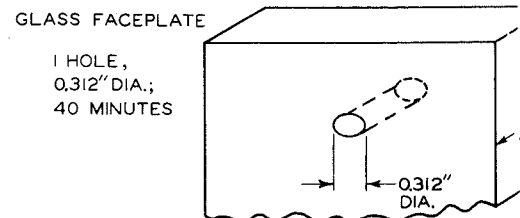
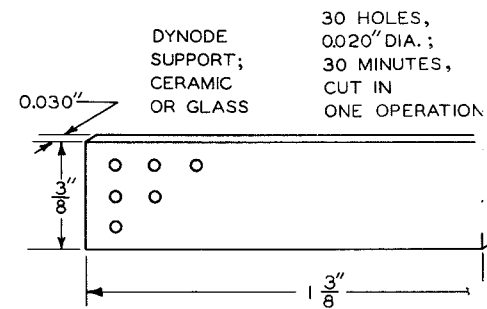

Fig. 4—Sketches of several pieces of different size and shape cut by the ultrasonic grinding method.



Fig. 5—Typical mask used for the "pattern evaporation" of metals.

by the pyrometer to true temperature, which in each case depends upon the emissivity of the metal.

Seven brazing materials were found that are suitable for brazing molybdenum and tungsten. In order of decreasing melting temperature, they are osmium, iridium, an alloy of iridium and tin, ruthenium, an alloy of ruthenium and copper, an alloy of platinum and iridium, and rhodium. Osmium melts at a true temperature of about 2300 degrees Centigrade with molybdenum, while rhodium melts at about 1970 degrees Centigrade. The alloys of iridium and tin and ruthenium and copper can be varied in composition to give wide ranges in melting temperature. This range makes step brazing practical.

#### WELDING OF HIGH-CONDUCTIVITY AND HIGH-MELTING-POINT METALS

Resistance welding has been used for a long time as a convenient means of joining metals. Because the equipment required to do the work is comparatively simple, the extension of this process to include high-conductivity and high-melting-point metals is desirable. This extension has been accomplished.

Resistance welding is essentially the coalescence, or melting and flowing together, of two pieces of metal as the result of electrical heating and pressure. For sufficient heat to be developed by  $I^2R$  losses, the resistance at the interface should be high. In the case of high-conductivity metals and high-melting-point metals, however, the resistance available is not high enough to produce the required melting temperature. A resistance weld of such materials by the use of conventional resistance welding equipment

requires that a suitable value of electrical resistance be supplied, and also that the melting point of the metal be reduced locally by the use of a lower-melting-point metal as a flux. In the case of high-conductivity metals, the use of a stainless steel insert in one of the welding electrodes to provide electrical resistance and of a silver-tin-copper alloy as a flux make possible the resistance welding, or resistance brazing, of silver, copper and aluminum. For the case of high-melting-point metals, molybdenum and tungsten may be joined by the use of platinum and iridium as a flux.

#### IMMERSION PLATING

Immersion plating is a process of plating metals without the use of a source of electrical current. This process, which is often called "electroless plating" because it is chemical and not electrochemical, is used for plating Kovar pins of pickup tubes. After the pins are cleaned, a short length of aluminum wire is wrapped around each pin to serve as an activator and the tube is immersed in an aqueous sodium stannate solution. As the aluminum dissolves, it ionizes posi-

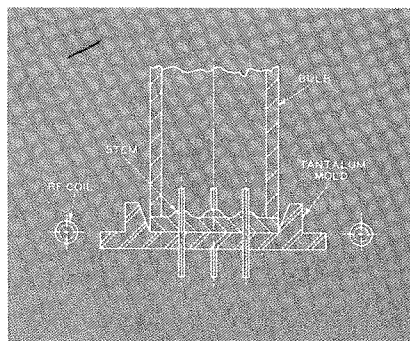

Fig. 6—Tantalum mold used in a new flameless sealing method.

tively, and thereby imparts a negative charge to the Kovar pin. This negative charge on the pin is sufficient to cause tin plating.

The preparation of the lead is accomplished by an acid-pickling process. Like immersion plating, this process does not require an electrical current source. Thus, an integrated process which does not require electrical current is available for cleaning and plating leads. Similar processes can be used for plating insulating materials.

#### CLEAN TUBE-SEALING METHODS

Some tube-envelope-making processes expose delicate screens and targets in the envelopes to contamination from the sealing process. Dirt in the gases produced by combustion, formation of carbon particles and the production of water vapor during this sealing process can seriously damage the delicate screens or targets. The use of flame-sealing methods can be eliminated by substituting other sealing methods. Among the sealing processes which allow tube closures to be made without the use of flames are: conventional induction seals which can be pre-heated and annealed by the use of an electrically heated oven, inert-gas arc-welding, and the frit seal used in the color kinescope.

A newly developed method of flameless sealing, which is used in making developmental miniature vidicons, is part of a series of processes carried out in an evacuated bell jar. The bulb assembly and the gun mount on its stem are loaded in the equipment, which is kept clean by being enclosed. When the bell jar has been evacuated and tube processing has been completed, the bulb is lowered to the stem which is supported on a tantalum mold as shown in Fig. 6. An induction coil surrounding the assembly is used to heat the mold and form a seal. Thus, the mount is not exposed to possible damage from flame sealing.

#### ACKNOWLEDGMENT

The author, in this survey, is merely a reporter, and he acknowledges that the development of and the useful applications of the processes described were the work of a score or more of capable individuals.

# MODERN INSULATION CONCEPTS

by

**SIEGMUND HALPERN**

*Components Engineering  
Defense Electronic Products  
Camden, N. J.*

**E**LECTRICITY CAN ONLY perform a useful function after it is harnessed and contained. It is the purpose of the insulation to provide the necessary physical barrier and dielectric strength to prevent voltage breakdown and damage to the apparatus.

There was little stimulus for analytical insulation research in the early days of electrical design, prior to the advent of the modern military equipment with its severe environmental and thermal requirements. Insulation used to be chosen largely by intuition, personal likes and experience, rather than on the basis of sound scientific principles. During the last 20 years concerted scientific research and free exchange of information transformed

High polymer materials are available in a variety of forms such as varnishes, resins, plastics and compounds, although their very nature defies clear-cut demarcation.

The process by which low molecular weight compounds are made to polymerize into high molecular weight compounds is often accelerated by the use of chemical catalysts. Outstanding examples of this type of polymerization are the various modern re-

are thermo setting. They are completely infusible and insoluble. Thermoplastic polymers on the other hand, such as cellulose esters, polystyrene, polyvinyl resins, etc. can be softened by application of heat and molded and remolded repeatedly. The distinction between thermosetting and thermoplastic materials is predicated upon the prevalence of cross-links between the high molecular weight constituents.

The thermosetting polymers are of greater importance in the electrical insulation field because of their inherent greater stability. Frequently the addition of fillers and plasticizers can improve or modify certain physical properties.

Nature provides a host of both organic and inorganic high polymers. All cellulose derivatives, for example, are organic polymers. Mica and asbestos are typical of the inorganic ones. A third type is the family of synthetic high polymers which are widely used in modern insulation systems. Many of them are derived from polyethylene, fluorocarbon and the previously mentioned polyester and epoxy resins. Familiar commercial insulation mate-

Group A—Linear reactors insulated for 30,000 volts, inductance is 8 Hy at 0.62 amps.

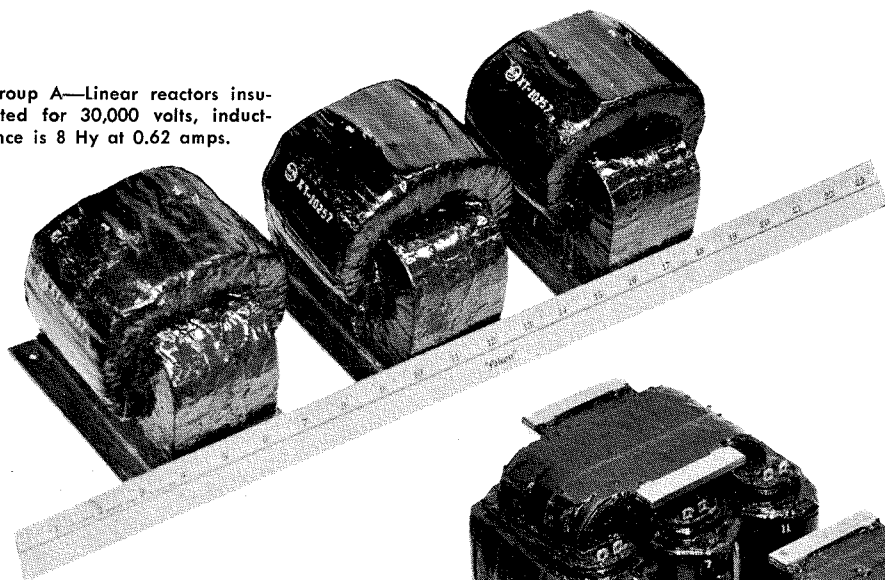

the field of insulation from a mere art to a sound science.

## POLYMERS

A better understanding of the molecular structure of chemical compounds has led to the realization that an increase in molecular weight is accompanied by desirable physical changes such as greater physical strength, improved thermal characteristics and greater resistance to chemical attack.

These high molecular weight compounds, also known as "high polymers," are composed of a great number of identical atomic structures held together by electrostatic forces or by valence electrons. Compounds which contain more than one structural pattern are designated as "co-polymers".

active solventless resins of the epoxy and polyester families. They are of special value in the electrical field because of their tendency to fill all voids and their good adhesion and shrinkage characteristics. One of the well known commercial transformer encapsulating materials, Fosterite, a polyester styrene co-polymer falls in this category.

Some high polymer resinous compounds such as phenolics and ureas

Two groups of high-temperature, high-voltage iron core components. Insulation materials are mica, Teflon, Fiberglas, and ceramic coated magnet wire. Encapsulated in a mica-filled silicone resin compound, units are capable of continuous operation at 225°C for 2500 hours.

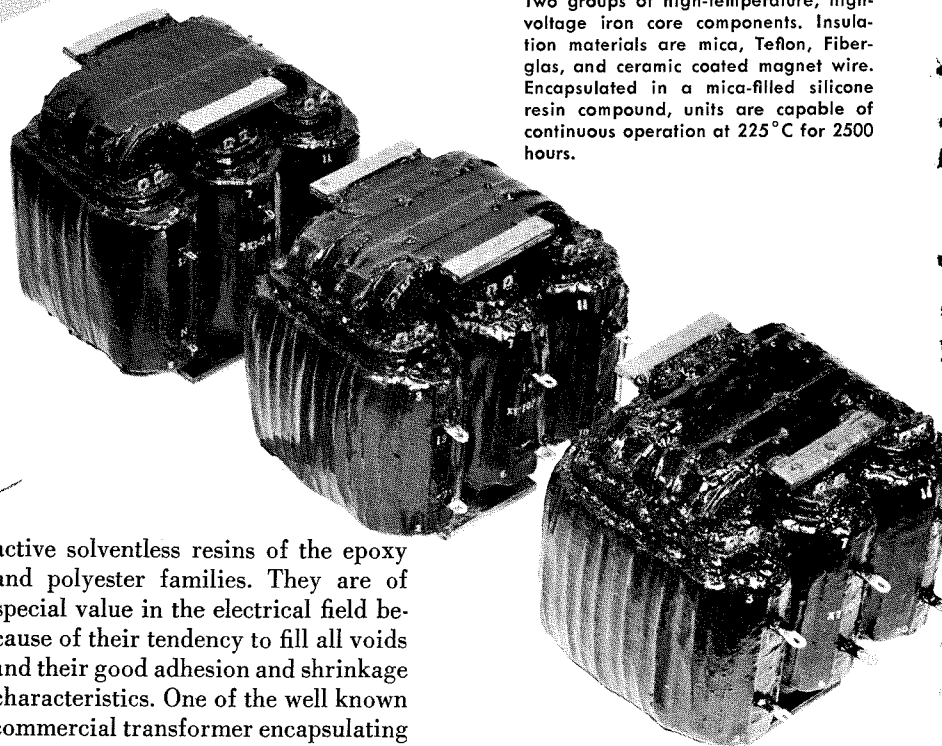

Group B—3-phase, 400 cps H-V plate transformers capable of delivering 13 KV at 0.5 amp d-c in full wave circuit.



Material	Dielectric Strength Volts/mil Short Time	Temperature Rating °C	Dielectric Constant	Moisture Absorption %	Tensile Strength lbs/in <sup>2</sup>	Volume Resistivity Ohms-CM	Chemical Resistance
KEL-F* (Polytrifluoro-Chloroethylene)	530	195	2.6	0	5000	10 <sup>18</sup>	Not resistant to some highly halogenated and aromatic compounds
TEFLON** (Polytetrafluoro-Ethylene)	400	250	2.0	0	2000	10 <sup>19</sup>	Not resistant to alkali metals and fluorine at high temperatures
POLYETHYLENE	550	90	2.3	.01	4500	10 <sup>18</sup>	Not resistant to aromatic chlorinated hydrocarbons
POLYSTYRENE	450	85	2.5	.05	7000	10 <sup>14</sup>	Not resistant to aromatic and chlorinated hydrocarbons
MYLAR** (Polyester Film)	4000	150	3.3	.5	17000	10 <sup>19</sup>	Not resistant to concentrated acids, alkalis
SILICONES (General)	350	250	4	.3	4000	10 <sup>14</sup>	Not resistant to concentrated sulphuric acid, acetone
NYLON	385	125	3.9	1.5	8000	10 <sup>14</sup>	Not resistant to strong acids, phenol
SILICONE RUBBER	1100	260	3.3	0.28	800	10 <sup>12</sup>	Not resistant to aliphatic and aromatic hydrocarbons
SILICONE GLASS LAMINATE	400	200	3.8	0.25	23000	10 <sup>14</sup>	See silicones

\* M. W. Kellogg Co.    \*\* DuPont

Fig. 2—Table showing the Electrical and Physical Data on several typical Insulating Materials.

rials such as Teflon, Mylar, KEL-F, and others are part of this group.

By substitution of silicon and oxygen for carbon molecules in organic compounds a new family of organo-silicon-oxide polymers has been created which revolutionized the insulation field. These polymers, known as the "Silicones", are available in forms of grease, insulating resins, rubbers, gums and fluids. The outstanding high temperature capabilities of the silicones applied to magnet wire and combined with such inorganic base materials as fiberglass, mica and asbestos provide us with an excellent insulation system applicable for instance to high temperature transformer work. In addition, mica-filled silicone resins can be used as an effective transformer encapsulating medium resulting in overall thermal capability of 250°C.

#### INSULATION CLASSIFICATION

The great variety of new insulation developments created a situation where the "time tested" insulation classes that appeared in the original AIEE Standard #1 entitled: "General Principles upon which Temperature Limits are based in the Rating of Electric Machines and Apparatus" deserved re-examination. It became apparent that insulation classification and use based on material composition did not guarantee reliability. This was especially true in cases where unusual environmental operating conditions prevailed. A revision of the AIEE standard #1 was issued in 1957 which introduced the new concept that temperature classification of insulation materials be based on experience, accepted tests, and on minimum thermal life values derived from a scientific aging program.

Here, at last, we have an entirely

new philosophy and modern approach. No longer are we bound by the rigid thermal classification based on chemical composition of the material, but we place our confidence in a "functional evaluation" of the insulation system. This type of evaluation involves the recognition of the various environmental and operational stresses which act upon the insulation concurrently with the thermal exposure. The revised AIEE Standard #1 very appropriately states in connection with the above: "The major factor affecting life of insulation material is thermal degradation. Moisture, chemical contamination and mechanical stress contribute to a failure especially after the material has been weakened by thermal deterioration."

#### FAILURE CRITERION OF INSULATION

A variety of failure criteria have been proposed, each having its advantages and disadvantages. Such characteristics as loss of tensile strength or decrease of insulation resistance or dielectric strength have been considered.

Before deciding on a failure criterion it is necessary to ascertain whether this criterion has functional significance in the operation of the apparatus. For example, loss of 50% of the tensile strength of insulation may be of no significance to the life of a transformer coil so long as the dielectric capabilities remaining are not marginal.

On the other hand, a loss of 50% of the original dielectric strength may be serious in those applications where full use of the dielectric capabilities of the material has been depended on. In the case of low voltage coils where the function of the insulation is more in the nature of providing proper spacing than dielectric barrier, end of life

data which are based on 50% reduction of dielectric strength are necessarily unrealistic. In such cases additional functional evaluation tests exposing such understressed materials to some or all of the other environmental deteriorating influences are necessary.

#### INSULATION DETERIORATION

The process of aging of electrical insulation involves both physical and chemical changes. Continued application of heat will cause softening and weight reduction of the insulation due to the loss of the lower molecular constituents. The result will be brittleness and eventual cracking. The chemical deteriorating effects are oxidation due to the presence of air, accompanied by molecular splits, cross-links in the polymer chains and formation of undesirable acid groups. The effect on the insulation is loss of flexibility and tensile strength and increase of conductivity. Other chemical deteriorating influences come from a tendency of slow de-polymerization at high operating temperatures with severe damage to the original performance capabilities. Frequently electrolytic reactions take place as a result of catalytic acids, formulated by the above mentioned oxidation process, or from substances in physical contact with the insulation. When the potential stress applied to insulation exceeds the ionization threshold of the surrounding gas, a distinct visible, and frequently audible discharge occurs, called "corona". Corona induced reactions include powerful oxidizing agents such as ozone. Simultaneously, nitrogen oxide is formed by breakdown of the air. The effects of the oxidizing and chemical agents on the already stressed insulation are apparent.

## DIELECTRIC BREAKDOWN

A great many factors influencing breakdown are still not fully understood. One theory states that the inferior fibers in the insulation will be excessively heated by the applied electric field and will deteriorate rapidly. The remainder of the insulation, now less homogeneous, follows suit.

Another theory is based on the concept of physical rupture of the dielectric under stress. The molecular disintegration is then followed by dielectric failure.

Before actual breakdown occurs there is usually some degree of stress concentration and corona due to protruding points. Eventually an electron avalanche and breakdown occurs. As long as the dielectric stress is present, there is also a certain amount of physical damage to the surface of the insulation by erosion. This is caused by the bombardment of the accelerated electron and ion particles.

Corona is probably the most serious damaging factor to insulation. Its effects can be ascertained in terms of rise of power factor. Water absorption of the insulation due to high humidity exposure is responsible for a reduction of surface resistivity and lowering of the corona threshold voltage.

## APPLICATION OF CHEMICAL RATES

The elevation of temperature increases the rate of deterioration of insulating materials. Instead of testing an insulation at its intended operating temperature until failure occurs to determine its life expectancy, it is possible to use a higher test temperature for a shorter period of time. A "rule of thumb" method, known as the "10 degree rule" was in use for many years. The latter states that the insulation life is reduced by 50% for each 10 degrees increase in temperature. While this method rendered quite acceptable results for low temperature insulation systems it was not accurate when applied to high polymer materials.

The modern concept of insulation life expectancy pioneered by Dr. T. W. Dakin,<sup>6</sup> is based upon the realization that the thermal deterioration of insulation as a function of temperature and time is analogous to a first order chemical reaction. Such a reaction is governed by the Arrhenius equation.

$$k = Ae^{-\frac{E}{RT}} \quad (1)$$



**SIEGMUND HALPERN** received the greater part of his education in Vienna, Austria, where he completed Realgymnasium and graduated in 1938 from the Institute of Radio Technology at the Technologisches Gewerbemuseum with a Diploma in Radio and Electrical Engineering. From 1944 to 1947 he attended evening sessions at City College of New York for further engineering studies.

In 1941 he joined New York Transformer Company, where he was engaged in test and design of iron core components for military equipment. From 1945 to 1947, Mr. Halpern directed the engineering and research activities of the transformer division of Radio Development and Research Corp., including designs of components for the Princeton University Cyclotron.

From 1947 to 1951 his work was concerned principally with the design of broadcast and pulse components, regulated power supplies and magnetic amplifiers at Langevin Manufacturing Corp.

Since joining the Transformer Engineering Section at RCA as AA Engineer in 1951, Mr. Halpern has designed a variety of specialized iron core components for broadcast, computer and systems applications. He has been conducting extensive research on high temperature transformers used in airborne equipment, and is also in charge of magnetic amplifier and filter research projects.

Mr. Halpern is a Member of AIEE, a Senior Member of IRE, and a member of the American Society of Metals.

where  $k$  = reaction rate  
 $E$  = activation energy  
 $R$  = gas constant  
 $T$  = absolute temperature (Kelvin)  
 $A$  = frequency of molecular encounter.

This equation can be modified to show that the natural logarithm of insulation life is a linear function of the reciprocal of the absolute aging temperature.

$$\ln \text{ life} = \ln A + \frac{E}{RT} \quad (2)$$

The analogy to a basic linear equation of the form  $y = a + bx$  is apparent when we set

$$y = \ln \text{ life} \quad a = \ln A \quad b = \frac{E}{R}$$

$1/T$  represents the reciprocal of the aging temperature in degrees Kelvin. The constants  $A$  and  $E/R$  constitute

intercept and slope of the so called "regression line".

The task of plotting a straight line relationship of log life versus  $1/T$  suitable for extrapolation for a particular insulation material is resolved by finding values of  $A$  and  $E/R$  and plotting the regression line. The procedure calls for statistical analysis of life data from a number of heat aging tests conducted at several aging temperatures. Then, by applying the principles of "least squares method" and statistical correlation the intercept  $A$  and the slope  $E/R$  of the regression line are found and substituted in equation 2 which renders the regression line equation. AIEE standard 1F outlines this statistical analysis in full detail.

## CONCLUSION

A better understanding of the molecular structure of electrical insulating materials form the basis for modern insulation concepts. Both advantages and limitations of the various high polymer materials are seen with proper perspective by functional analysis of their intended use. Finally, the application of the chemical rate theory to insulation deterioration combined with the judicious use of statistical methods have furnished the electrical engineer with a new powerful tool.

## REFERENCES

1. W. H. Horton, "A Statistical Method for Predicting Insulation Life From Experimental Data," AIEE Paper 56-177, June, 1956.
2. T. W. Dakin, H. M. Philofsky, W. C. Divens, "Significance of Thermal Aging Tests on Flexible Sheet Insulation," AIEE Conference Paper.
3. A. L. Scheideler, "Significant Measurements for Determining the Stability of High Temperature Magnet Wire Insulation," AIEE Technical Paper 54-71, November, 1953.
4. L. C. Whitman, Paul Doigan, "Calculation of Life Characteristics of Insulation," AIEE Technical Paper 54-72, November, 1953.
5. T. W. Dakin, "Physics of Insulation," *Westinghouse Engineer*.
6. T. W. Dakin, "Electrical Insulation Deterioration Treated as a Chemical Rate Phenomenon," *AIEE Transactions*, Volume 67, Part 1, 1948.
7. "Guide for the Preparation of Test Procedures for the Thermal Evaluation of Electrical Insulating Materials," AIEE NO 1D, June, 1957.
8. "Report on Guide for Statistical Analysis of Test Data," AIEE NO 1F, June, 1958.
9. "Guide for the Preparation of Test Procedures for the Thermal Evaluation of Insulation Systems for Electrical Equipment," AIEE NO 1E, June, 1957.
10. Graham Lee Moses, "Insulation Engineering Fundamentals," Lake Publishing Co., 1958.

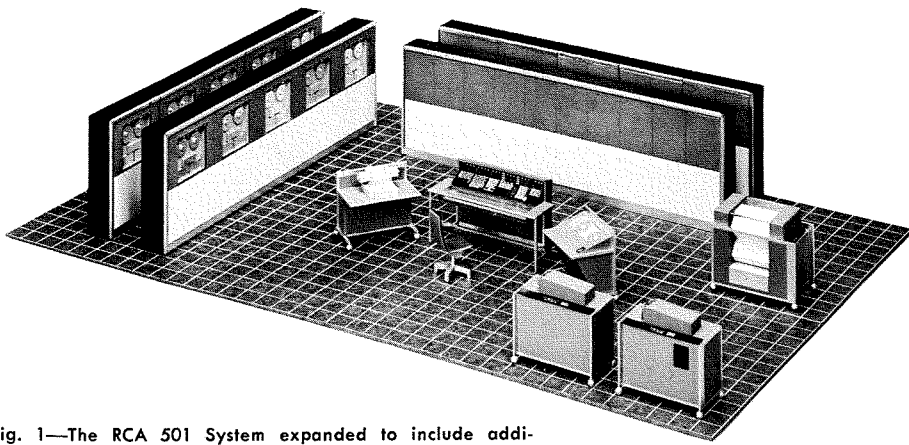

Fig. 1—The RCA 501 System expanded to include additional tape stations (left) and Punched Card Input and Output.

## RCA 501 HIGH-SPEED PRINTERS— THE STORY OF A PRODUCT DESIGN

by

**C. C. ECKEL and D. FLECHTNER**  
*Electronic Data Processing Division  
Industrial Electronic Products  
Camden, New Jersey*

THE 501 HIGH-SPEED Printer is an output device of the RCA 501 Electronic Data Processing System. This system is fully transistorized. It is expandable in both the area of the High Speed Memory and the Input-Output Devices. In the specific case of the High-Speed Printer, this expandability takes the form of optional use of the printer mechanism either as an On-Line device or an Off-Line device.

Initially, the 501 product plan was to design and produce a minimum cost E.D.P. System. Therefore, the first printer specifications called for On-Line operation with the printer being driven directly by the computer. This accomplished two things. It held the cost of printer electronics to a minimum, but, still allowed the system to have a high-speed output capability.

Subsequent product planning developed the need for system expandability, that is, a system which could be enlarged at the user's convenience if the work load increased. To meet this requirement, a program was also started to design buffer electronics to allow the printer to be run directly from magnetic tape—Off-Line.

Fig. 1 shows a scale model of the RCA 501 System. Information is entered through the Paper Tape Reader at 1000 characters per second. Printed output is available from either the Monitor Printer or the On-Line

Printer in a basic system. The expanded system provides for punched card input and output and additional magnetic tape storage. The High-Speed Printer can be expanded to an off-line device with buffer electronics permitting it to operate from magnetic tape.

### PRINTER DESCRIPTION

The specifications set up for this printer were that it should be capable of printing at least 600 lines per minute with 120 columns per line. It should be capable of producing at least an original and three carbon copies, offset masters and ditto masters, and contain the necessary logic to be applicable in all types of format printing. Not an integral part of the design specifications, but perhaps most

important overall, were the criteria that the printer should be low enough in manufacturing cost, but high enough in performance so that these factors alone could ward off early obsolescence. A corollary to this was the fact that the length of design cycle must be held to a minimum and the design cost should be reasonable.

The mechanism selected for the printer was of the "flying wheel" variety. Basic techniques employed in printers of this type are well known. Therefore, only the functional aspects that illustrate the product development will be explained.

Fig. 2 shows a flow diagram for the On-Line Printer. Information to be printed is stored in the High Speed Memory of the Computer and the format is controlled by a program in the Computer Program Control. The memory contents are scanned and a line is printed with each revolution of the print wheel cylinder. Synchronization of the memory and the character identity coming into position to be printed is accomplished by a photo-electric code disc assembly, mounted on the same shaft as the print cylinder. The coded bits emerging from this disc are mechanically phased with respect to the character they represent on the print cylinder. This allows sufficient time for a particular character to be compared for its occurrence in the Computer's memory and if it exists, a bit is placed in the shift register corresponding to the proper print column. A clock pulse from the Computer then causes printing of this character identity. The process is continued until the Computer Memory has been examined for all 51 possible printing characters. The Computer next generates a signal

Fig. 4—The Print Drum area, ribbon assembly removed.

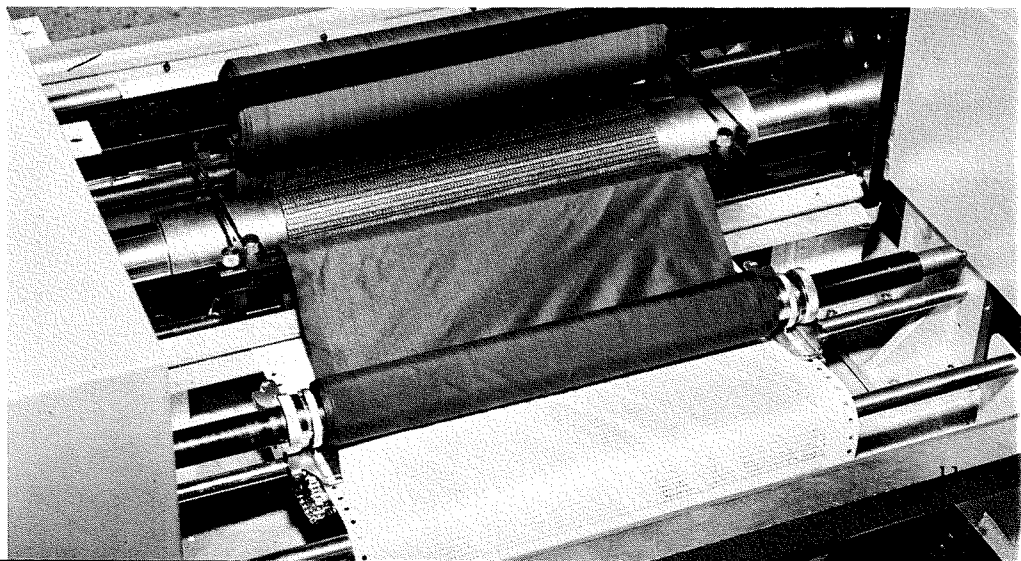

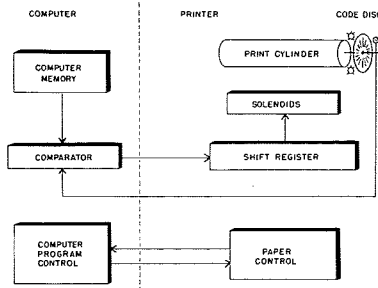

Fig. 2—On-Line Printer Flow Diagram

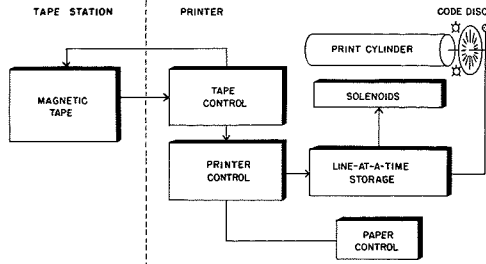
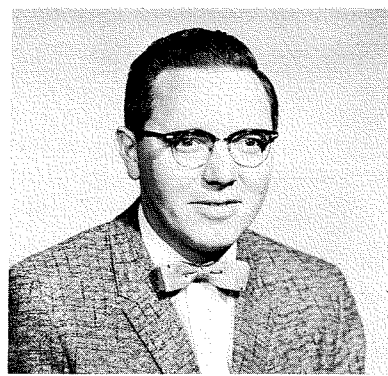

Fig. 3—Electro-Mechanical Printer (Off-Line) Flow Diagram.

indicating the amount the paper should be moved, and upon receipt of a return signal indicating that the paper has been moved, the entire process is repeated.

Fig. 3 illustrates the Off-Line operation employing suitable buffering logic. The buffer unit is designed to accept one line of information at a time, from magnetic tape, store it temporarily, and then print it out. The line is stored in a core memory, the input to which consists of a coincidence between character identity and column location. The memory is clocked out by the photo-electric code disc assembly as each character identity comes into print position.

Printing is normally accomplished in an asynchronous manner. That is, provision is made to determine when all character identities to be printed on a line have been printed. Upon receipt of this signal, another line of information is immediately read in from



**CARL C. ECKEL** received a degree of Mechanical Engineer from Stevens Institute of Technology in 1950.

He joined RCA in 1953 and worked on the logic and circuit design for various Computer Input-Output devices. These included the Ultra-type Camera and High-Speed Printer. Mr. Eckel was promoted to his present position of Leader, Design and Development Engineers in 1957 and is responsible for both on-line and off-line printer equipment.



**D. FLECHTNER** received his BS degree in 1947 and MS degree in 1949 in Mechanical Engineering from Stevens Institute of Technology.

He joined RCA in 1953 as a project engineer with responsibility for design of the Electro-Mechanical Printer. In 1955 he was made a Leader and in 1957 was appointed to his present position of Manager, Input-Output Devices Engineering. In this capacity he is responsible for design of all peripheral devices for Electronic Data Processing Systems. These included Magnetic Tape, Punched Paper Tape, Punched Card and High-Speed Printing Devices.

magnetic tape as the paper is shifted. In this manner, basic printing speeds may exceed 600 lines per minute reaching as high as 900 for numeric printing. The logical circuitry in this area also serves as an accuracy check on the number of characters printed versus the number of characters which should have been printed.

In order to control the printed format, several features have been incorporated. First, by means of a plug-board, incoming information may be tabulated to any of 24 predetermined positions; this same feature may also be used to delete information which is not wanted. It is also possible to effect multiple printing of the same data on one line, again by use of the plugboard.

Fig. 4 shows the printer mechanism, which is used for either the on-line or off-line operation.

#### FACTORS INFLUENCING PRODUCT DESIGN

The need for economical high-speed printers for computer output has persisted. Both electronic and electro-mechanical printers were considered, and from an economic and state of the art point of view, the electro-mechanical seemed more promising. Rotary wheel printers (Fig. 4) looked to be the best compromise as far as simplicity of mechanism and high printing speed are concerned. Earlier equipments were designed using mechanical printers of this type. Since RCA already had experience with this type of printing mechanism (certain problems were known to be problems) the new product development for the RCA 501 System consisted of refine-

ments and improvements in the techniques. It was already known how to make good print wheels, how to be consistent with the solenoid fabrication, and the many other necessary techniques.

#### PAPER SHIFTING

An area needing some investigation was that of high-speed paper shifting. At the time the project was initiated, RCA had a development design of an electro-mechanical spring clutch which gave promise of very high speed paper shifting. It was found, however, that a magnetic clutch, suitable for paper shifting, though not quite as fast, was already commercially available, and so it was adopted.

In order to appreciate the problems involved in fabrication of the print solenoids let us examine for a moment the general concept of print quality. Admittedly, this is a subjective type of thing and depends primarily on the ability and the resolving power of the human eye.

It was found, for example, that it is possible to detect a vertical misalignment of about .005" between adjacent characters in a line of print without much difficulty. In the conventional typewriting or typesetting, where similar misalignments occur more frequently in a horizontal direction, the effect is not generally displeasing. People are more familiar with this type of printed copy and they usually accept it without notice. However, they detect any vertical misalignment quickly and question its reason for existing.

LINK  
LINK

Fig. 5—Vertical print misalignments, (a) normal (b) .005-inch above and below a line.

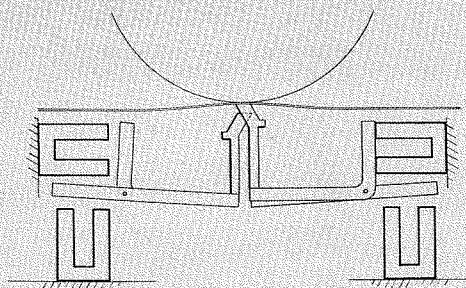

Fig. 6—Print hammer action.

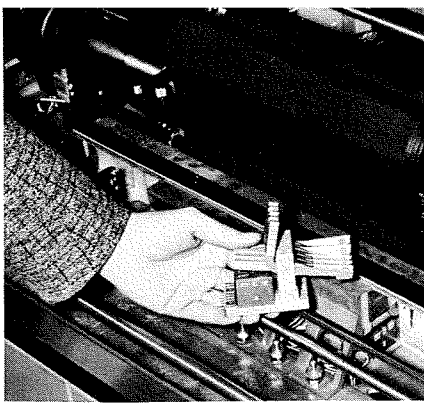

Fig. 7—Solenoid and print hammer assembly.

Fig. 5 shows the word "link" in which the "i" is .005 inch above a line and "n" is .005 inch below the line with "l" and "k" on a line. Here, also, the irregular horizontal spacing can be seen in the top word, a design requirement of wheel printers. This difference in spacing is readily accepted because of the differing widths of letters.

Vertical misalignment is a normal consequence of rotary wheel printers which must be minimized. The primary way in which this is done is to assure that all 120 solenoids are as near alike as possible both electrically and mechanically.

From an ease of manufacturing and of maintenance standpoint, placement of the print solenoids is preferred in two banks, one on each side of the print wheel center line; that is, 60 per side, so that all the solenoids would be similar. However, the problem of getting enough energy into and out of a solenoid, which is only 2/10 of an inch thick, without crosstalk, resulted in a design compromise of two banks of solenoids on each side. It was found that, with the two-bank design, the solenoids could be assembled and potted in groups of five. Fig. 6 is a representation of the solenoid area of the printer.

The potted assembly of five solenoids is machined in a single operation so that the tolerances can be held. This technique is similar to that used in fabricating digital magnetic recording heads. By this means, good solenoids can be economically made with the correct tolerances built in, thus eliminating later assembly adjustment. Fig. 7 shows the solenoid area with a view of an individual unit.

#### CODE DISC

Another area of investigation centered around the code disc. This assembly has the function of establishing the

angular position of each character on the print drum and translating the character into coded notation. The code disc has perforations corresponding to the 7-bit code used in the RCA 501 System. Fig. 8 shows the code disc area.

Here manufacturing economies were affected by photo-etching through a plate to obtain the coding.

#### COST AND MAINTENANCE FACTORS

The logic of the On-Line and Off-Line Printers is implemented with circuit boards of standard configuration. Most are the same board types used elsewhere in the System (Fig. 9).

The use of standard plug-in packages (also used in the Computer and the rest of the units of the System), also helps to keep manufacturing and service costs down.

Design for simplification and ease of field maintenance meant that the logic should be straightforward and easy to understand. All necessary adjustments should be in convenient locations and the mechanism should be designed in modules which are easily replaceable, such as the print drum, ribbon drive and paper shift assembly. In the on-line case, a small maintenance panel simulates the Computer so that the unit can be serviced independently without tying up the rest of the System.

#### CONCLUSION

In the Computer Field, the major problem encountered in product design is time. The technology is advancing at a rate which constantly makes new products obsolete in the design stage. The Product Design Team must carefully weigh the technological advances which can be incorporated in a design

against the need for production release so that the device can be made ready for sale. To insure that the product design remains saleable, the following three items are basic. First, the design should be functionally good. Second, it should be reliable, and third, it should be reasonably priced. When these characteristics are achieved in a product design, regardless of technological advance, the product will not become obsolete—it will remain marketable.

Fig. 9—Typical plug-in transistor circuit board.

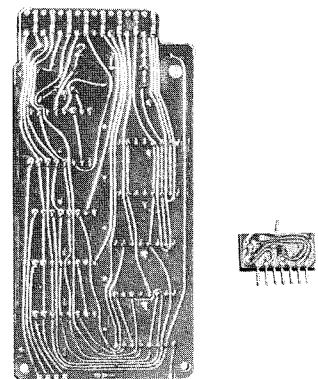
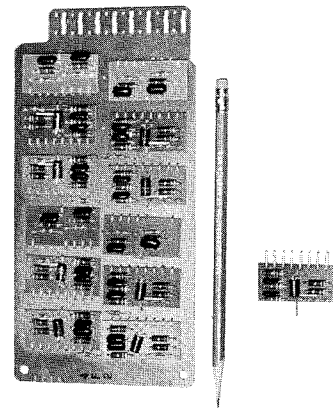
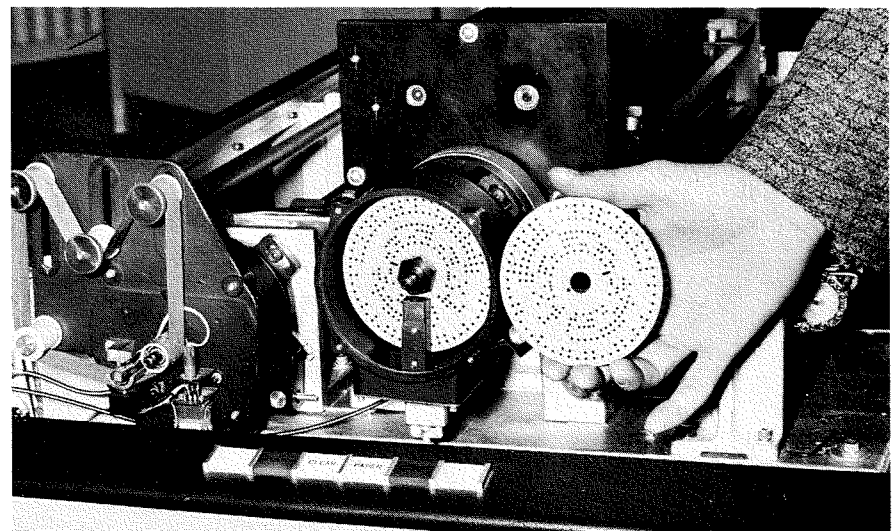

Fig. 8—Code disk.





# COLOR TELEVISION RECEIVERS

by

A. J. TORRE

*Color Television Engineering  
RCA Television Division  
Cherry Hill, N. J.*

THE STEADY ADVANCES that have been made in the design and performance of RCA color television receivers, over the past six or seven years, is a story of engineering progress deserving considerable emphasis.

This paper is intended to describe only a few of the highlights in tracing the evolution of RCA's commercial color television receivers, along with the corresponding progress made in related areas such as the engineering of RCA color kinescopes and color broadcasting equipment and facilities, and in color television receiver components.

## THE 1953 CT-100 MODEL

The first color television receiver commercially produced was the 1953

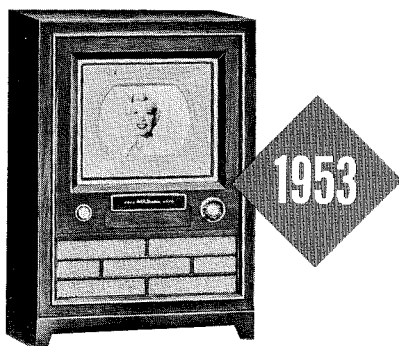

Model CT-100 (1953)

Model CT100. This was a 37-tube instrument using the 15" shadow-mask kinescope. Circuitry for this product was an integration of previous experimental models built over a period of years for color television demonstrations and N.T.S.C. field tests. The CT100 was of immeasurable value in that it was the pilot run for mass production. It proved that color kinescopes and receivers could be manufactured on a quantity basis, and provided a vital stimulus for the broadcasting industry as an interim studio monitor. Its complete flexibility of adjustment and set-up ideally suited it for this service. As was true in the case of RCA's first monochrome receiver, the "630TS", so did the first RCA commercial color television receiver establish a reputation for fidelity of performance.

## THE MODEL 21CT55

For the second year of commercial color television, RCA produced, in limited quantities, the Model 21CT55 priced at \$995.00, introducing the 21" metal-cone color picture tube. The nucleus for this receiver design was its predecessor, the CT100, which was modified to accommodate the increase in picture area and deflection angle. The basic issue at stake here was—could a 21"-70° tricolor shadow-mask kinescope be successfully mass-produced?



Model 21-CT-55 (1954)

The answer, after much effort and technical advance, was a resounding "yes". This receiver design had also introduced new challenges to the circuit designer in that the deflection requirements had increased, high-voltage performance had to be improved, new components needed to be developed, and a new design area in kinescope beam convergence had opened up. All these additional requirements were in the face of rising material costs and a vital need for reduced manufacturing cost.

The 21CT55 model was also well accepted, and served the broadcasters well as both a monitor for control purposes and as a monitor for the studio audience. Many of these units are still in use, having given remarkably trouble-free service and long life.

## THE 21CT600 COLOR RECEIVER

Once the primary issues of mass production had been resolved, the next major issue, cost, was attacked. The 21CT600 series, produced in 1955, represented RCA's first major step toward reduced manufacturing cost for color television receivers. The quantities for this series were substantially increased over past products by a factor greater than ten. A broad line of merchandise was marketed for the first time consisting of five models. This expanded line and the increased quantities did much to lower cost and stimulate interest. The basic design, which reduced total tubes from 36 to 26, also contributed greatly toward reducing costs.

Many new technical concepts were

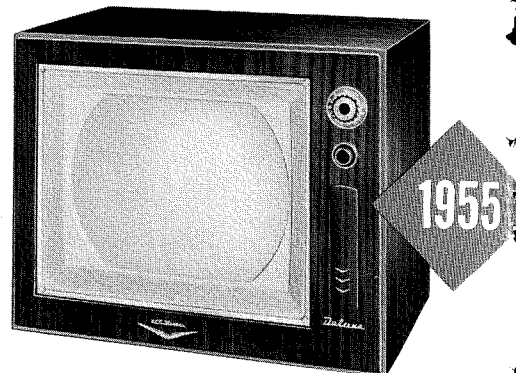

Model 21-CT-660 (1955)

used and introduced. A narrow-band i-f was used in conjunction with a "chroma peaker" in the color video circuit; kinescope adding of the luminance and chrominance signals was used rather than costly matrix adders; simplified procedures of kinescope set-up were introduced as well as many other advances.

The 21CT600 provided the opportunity to field test many new techniques, and achieved an overall cost reduction in the order of 35%.

## COST REDUCTION CONTINUES

The following year's color product had for its goal further cost reduction, improved performance, and increased reliability. Two levels of performance were built into the 700 Series, the basic difference between the Standard and Deluxe being confined to audio performance differ-

ences, variations in color video circuitry, and the omission of certain customer-operated features. The Deluxe models utilized wide-band color video as against a bandwidth of 500 kc for the Standard models. Radically different circuitry was used in this portion of the design to produce the difference in bandwidth. Both versions proved to be satisfactory.

Others were busy in the color field too. Telecasting had materially expanded, network facilities were greatly extended, and new studio equipment and techniques devised. The most notable of these were probably the improvements made in color encoders and in live camera chains. The Three-Vidicon Film Camera Chain made color film available for broadcasting for the first time, greatly adding to programming flexibility.

Components made progress as well.

color challenge, and considerable training was well under way. Sales techniques had been tried and proved. Broadcasting facilities had been expanded and "know-how" acquired.

With this foundation to build upon, and with the introduction of an all-glass tri-color shadow mask kinescope, the "800" Series color line was formulated. Foremost among the advances accomplished in the 21CYP22 was, of course, the all-glass construction which greatly simplified the mounting and insulation problems for the set designer (see Fig. 1).

At the same time, this new construction posed new unknowns to the circuit designer; mainly, the elimination of the metal envelope considerably altered the magnetics of the picture tube. Since most kinescopes are affected by magnetic fields, the effect of the earth's magnetic field and

shown that at least 75 to 80% of the product requires only a "degaussing" operation on installation to accommodate changes due to the earth's magnetic field. The service industry has fast learned to appreciate this "800" series feature which permits purity adjustments to the kinescope to be left untouched so that more lengthy adjustments will also remain correctly set.

#### THE 1959 "M" SERIES

Commercial experience last year with the "800" Series served to further justify our faith in this color receiver to the extent that it was decided to continue with this product, with minor modifications, into the 1958-59 market. This brand new 1959 line is referred to as the "800M" Series which is described in this paper.

The "M" Series utilizes a total of 26 tubes including the kinescope, two

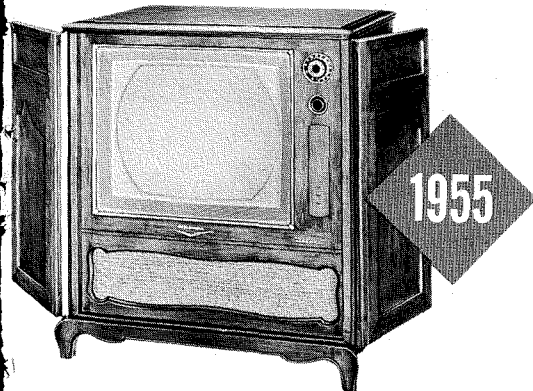

Model 21-CT-664 (1955)

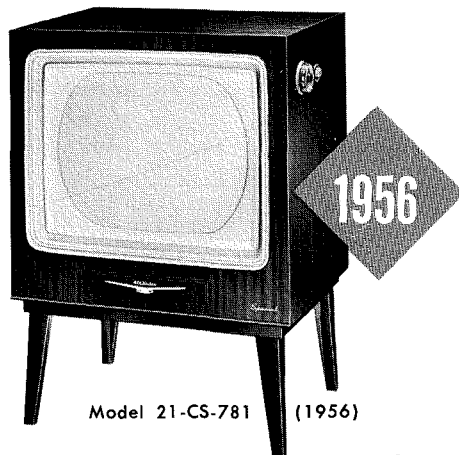

Model 21-CS-781 (1956)

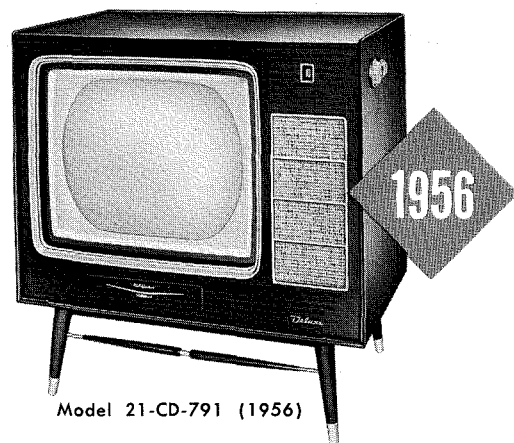

Model 21-CD-791 (1956)

The delay line used in color television receivers was available from a number of sources and at a reasonable cost. Deflection yokes achieved uniform performance and, as a consequence, reduced the cost. These advances, coupled with further increased quantities, brought costs down significantly to the extent that the first color television receiver selling for under \$500.00 was introduced.

#### THE 1958 PRODUCT LINE

In preparing for its 1958 product line, RCA had behind it a wealth of experience in design, manufacturing, service, sales, and broadcasting. Four basic chassis designs had been produced, two RCA manufacturing plants had built color receivers, the mass production techniques of printed circuits had been applied to color, the service industry had accepted the

other related problems had to be investigated and solved. Utilizing a Helmholtz chamber, studies were carried on which made these phenomena understood.\* The outcome of this investigation was a combination mounting and shielding treatment which adequately protected the tube from damage in shipment, supported the tube in such a manner as to facilitate necessary adjustments, and provided an adequate quantity of magnetic material correctly located for shielding. This shielding, in conjunction with our instrument plant's procedure for picture purity adjustment, has resulted in an extremely satisfactory method of service installation. Experience in this area has

\*B. R. Clay, "The Effect of Magnetic Fields on Color Television Receiver Performance," RCA ENGINEER, Vol. 1, No. 5 (Feb.-Mar., 1956) p. 16.

germanium diodes, and two silicon diodes. The silicon diodes are used in the low-voltage supply as full-wave voltage doublers. These rectifiers are one of the changes from the original design and allow a 50-watt reduction of input power. This reduces cabinet temperatures and enhances reliability. The silicon diode has given virtually trouble-free service.

#### GENERAL TECHNICAL DESCRIPTION

The chassis is self-contained with the exception of a small cabinet-mounted printed circuit that contains the convergence adjustments and circuitry. Five printed-circuit boards are used on the main base—the picture i-f, the sound and audio, the luminance channel, the vertical deflection, and the horizontal synchroguide. The balance of the circuit functions—that is, the low voltage, chrominance, color afc,

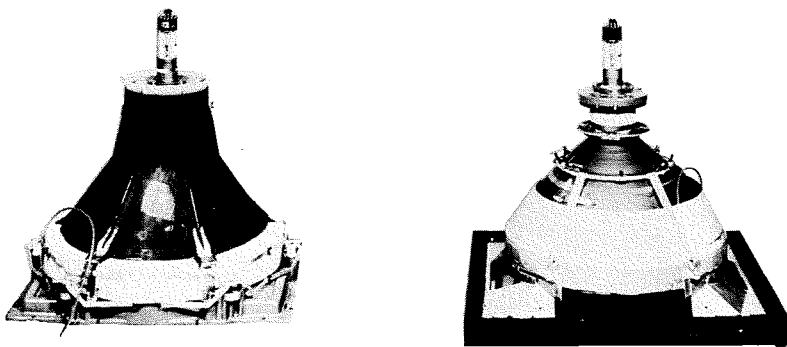

Fig. 1—Photo of glass and metal kinescopes.

and horizontal deflection-high voltage—are conventionally wired.

**SIGNAL FLOW**

A block diagram of the signal flow and tube functions is shown in Fig. 2. Conventional design criteria are used in the tuner design and its specifications vary little from black-and-white receiver requirements. The tuner has a cascode r-f stage—using

and-white sets. In color television receivers where a regulated high-voltage supply is used, a constant horizontal pulse amplitude is maintained, allowing the use of a triode rather than a pentode for AGC.

**THE PICTURE I-F**

One of the most important segments of the "800M" color television receiver is the picture i-f, which em-

tectors for sound and video in the last picture i-f stage provide adequate sound performance, and offer the desired degree of freedom from 920-kc cross modulation. Specifications for the threshold of unacceptable cross modulation between the sound carrier and the color subcarrier is a ratio of sound-to-picture carriers of 4/1. The video modulation used for this test is a fully saturated color bar signal. The i-f design meets this performance.

**SELECTIVITY**

The overall selectivity from tuner r-f input (Channel #4) to the output of the video detector is shown in Fig. 3. Both picture carrier and color subcarrier are at approximately 50% response. The accompanying sound is attenuated in excess of 2000 times, as is the adjacent sound carrier. The adjacent picture carrier is attenuated

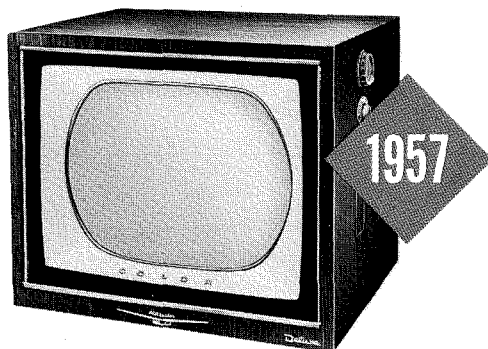

Model 21-CD-872 (1957)

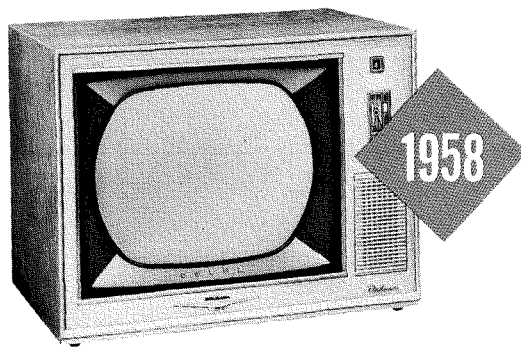

Model 21-RC-897 (1958)

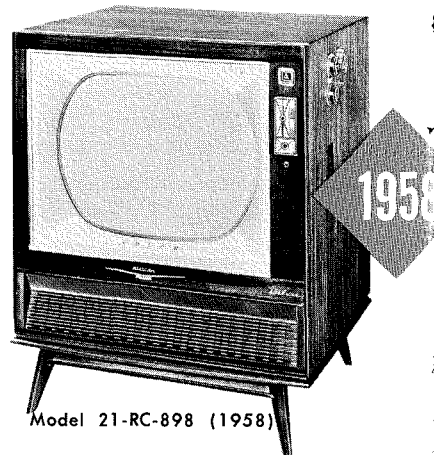

Model 21-RC-898 (1958)

the 6BC8 remote cut-off twin triode and a 6CQ8 for the oscillator-mixer function. The sound and audio, the AGC, the noise inverter, the "sync" separators, the vertical oscillator-deflection circuits, and the horizontal synchroguide are all essentially conventional and are not described in detail. Although conventional in configuration, considerable engineering is required in customizing these circuits to the requirements of a color receiver. Examples are the provision of signal sources in horizontal and vertical deflection for the convergence circuitry, and provision of high drive and accurate phase stability for the horizontal oscillator, making possible the high-voltage power needed and providing the keying pulses for color burst amplification and blanking.

AGC is one function where a simplification can be made over black-

plays a three-stage stagger-tuned i-f system. The sensitivity, selectivity, phase characteristics, and cross modulation are determined here.

The mixer plate circuit is a low-side, capacity-coupled stage with an accompanying sound trap and a "bridged" adjacent sound trap. The picture carrier and color subcarrier are at approximately 70% response in this stage. For the 1st and 2nd picture carrier and color subcarrier circuits are used—the first being tuned to approximately the picture carrier and the second to the color subcarrier. The third i-f stage utilizes a relatively large tube in the interest of linearity and voltage output. A broad single-tuned bifilar with a bridged sound trap in the secondary is used in this stage. The plate circuit feeds the 4.5 mc sound detector. Experience indicates that separate de-

by 350 times in this system.

Of some interest, particularly from the standpoint of sound performance, is the overall selectivity to the sound take-off detector. The picture-to-sound ratio nominally is 15/1, conventional for intercarrier sound operation.

**"BOOTSTRAP" VIDEO AMPLIFIER**

A "bootstrap" amplifier is used for the first video. Although this circuit is difficult to handle on the input side, other advantages offset this small inconvenience. The low-side "bootstrap" output provides the necessary gain without polarity reversal to drive the 12BY7 video output amplifier stage. The plate of the "bootstrap" amplifier feeds the synchronization and AGC circuits. This same plate circuit also contains a "peaker" circuit which is tuned to approximately 4.0 mc. The low-frequency side of

this tuned circuit is complementary in slope to the color subcarrier side of the picture i-f. Consequently, a response symmetrical around 3.58 mc is obtained when the overall i-f selectivity is added to the "peaker" selectivity. The color subcarrier is at 100% response with a 70% response of  $\pm 500$  kc. This, of course, is the desired bandwidth for double-side-band color operation. An over-coupled double-tuned bandpass transformer follows this overall chroma characteristic and further enhances the color bandwidth. The secondary of the first bandpass transformer is a low-impedance point which is a convenient location for the chroma control, as well as a place to introduce a voltage that disables the second-bandpass amplifier in the absence of the color synchronizing burst.

A triode second-bandpass amplifier is used. The plate circuit is a broad-band single-tuned bifilar transformer. The cathode of this stage is keyed positive, cutting the tube off during burst time. If the burst were not eliminated, its detection by the demodulators would create a pulse during horizontal retrace time which would upset the operation of the matrix amplifiers and cause a color shift between black and white and color operation.

#### DEMODULATORS

Low-level triode demodulators are used for color decoding. Ten volts peak-to-peak of properly phased 3.58 mc signal is impressed on the cathodes with the incoming chrominance signal being fed to the common control grids. The "X" demodulator is operating approximately  $9^\circ$  off the  $-(R - Y)$  axis, toward burst. The "Z" demodulator is separated from the "X" demodulator by approximately  $65^\circ$ . The plate circuit of the demodulators uses simple series peaking. The peaking coil is designed to be self-resonant at 3.58 mc for minimizing radiation of the sub-carrier.

The particular angles for demodulation are dictated by the relative gain of the demodulators, the gain of the matrix tubes, and the choice of the "Y" taps for R, G, & B. The matrix amplifiers have a common cathode resistor which has for a signal a mixture of the three individual plate signals,  $(R - Y)$ ,  $(B - Y)$  and

$(G - Y)$ . Since no signal is fed to the grid of the  $(G - Y)$  amplifier, the signal on its cathode must in effect be  $(G - Y)$ . Going further back into the system, the signal between grid and cathode of the  $(R - Y)$  amplifier is "X"  $-(G - Y)$  or  $-(R - Y)$ . Likewise, the  $(B - Y)$  amplifier derives its signal from "Z"  $-(G - Y)$  or  $-(B - Y)$ . All three matrix amplifiers are resistance-coupled using no peaking coils. A-C coupling is used to these amplifiers since they are pulse-set by the use of a horizontal retrace pulse fed to the common cathode resistor. D-C information is restored in this fashion. This technique has proven effective in maintaining stable kinescope color temperature operation.

#### "KILLER" CIRCUIT

Color synchronization is achieved by the use of a balanced phase detector, reactance tube and crystal oscillator combination. This system of afc has been used in previous designs and performs quite well. The "killer" circuit is novel in that a noise-immune configuration is used. Three diodes are used for the combined purpose of phase detection for automatic frequency control and "killer" detection. One of the three diodes serves a dual purpose, once for afc and again for "killer" detection.

Push-pull burst in conjunction with equal but phase-displaced cw, with a burst-opposing component, is used for reactance tube control information (see vector diagram of Fig. 4).

The "killer" diodes are oppositely connected so that in the event of a strong signal without burst, equal cw signals are detected with a net d-c output of zero. Similarly, in the presence of random noise, the detected output of the individual diodes

is a combination of noise and cw. Since these signals are equal, the d-c outputs are also equal but opposite, with a resulting output again of zero. By this action, thermal noise does not produce a voltage which will activate the color video circuitry. The color video circuitry is activated by the presence of a burst produced by a net d-c output which results from the in-phase diode. This signal is roughly proportional in magnitude to the amplitude of the burst. (The d-c output would be in effect the sum of the voltages of diodes #2 & #3.)

#### CONVERGENCE

One of the most intriguing sections of a color receiver is the convergence circuitry. The process of picture registry is complex, and is controlled by a number of parameters. First of all, the geometry of the tube is of fundamental importance, next followed by the scanning system and its components. After these, the effects of the deflection fields and their coupling to the pole pieces must be considered. Finally, techniques of tube purification must be taken into account.

The "800" Series product uses a system of convergence which has found favor in the industry. Probably the most trying of the field service adjustments has been convergence, but circuit advances have greatly minimized this problem.

The approach taken is to divide the picture into segments which are almost entirely independently adjustable. The picture can be thought of as being separated into five zones—the center of the raster, the right-side horizontal center, the left-side horizontal center, the top vertical center, and the bottom vertical center.

To converge the center portion of

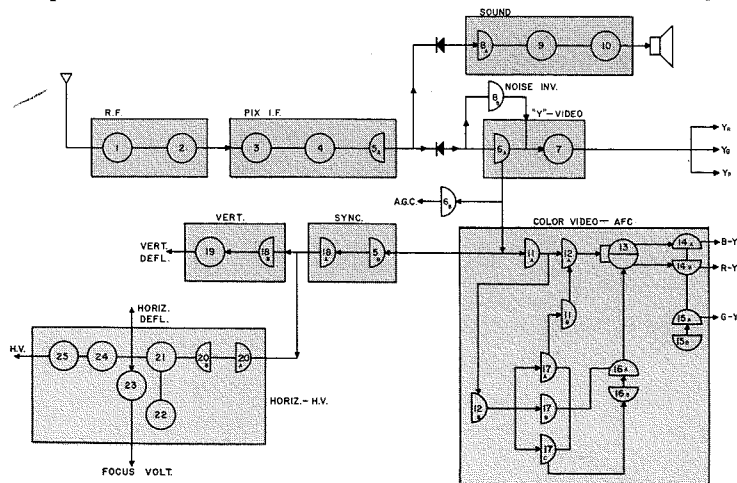

Fig. 2—Block diagram of the 800 M chassis showing signal flow and tube functions.

the picture, four permanent magnet adjustments are provided. In order to keep this portion of the raster independent of the dynamic adjustments, a d-c component is added and kept proportional to the a-c signals applied. (See Fig. 5.) D-C is supplied for the vertical by direct coupling from the vertical output cathode. Proper choice of resistance for the bleeder choke and controls, provides the desired degree of a-c to d-c tracking. Tracking for horizontal is achieved by using selenium diodes which rectify the a-c supplying the proper amount of d-c. These same diodes also are useful for waveshape improvement in that they have the effect of improving the horizontal parabola, and also providing left and right side zone separation.

Right-angle adjustments are provided to red and green for the horizontal corrections. Since the red and green pole pieces are symmetrically displaced from the horizontal and vertical axis, a correction current equal in amplitude and of the same polarity will cause a displacement between red and green in a left-to-right direction. Conversely, equal but opposite currents will cause a displacement between red and green in top-to-bottom direction. A fixed tilt variation is available for each pole-piece exciter coil by selection of its return point.

The corrections for blue are orthogonal by nature of the kinescope pole piece placement. The circuit arrangement and operation is similar to that explained for red and green.

For vertical correction, three similar circuits are used for R, G and B. Parabolic current waveshapes are employed which are potentiometer-controlled-independently, for each of the three colors. Tilt variation is supplied by a plus and minus source of saw-tooth current from the secondary of the vertical output transformer.

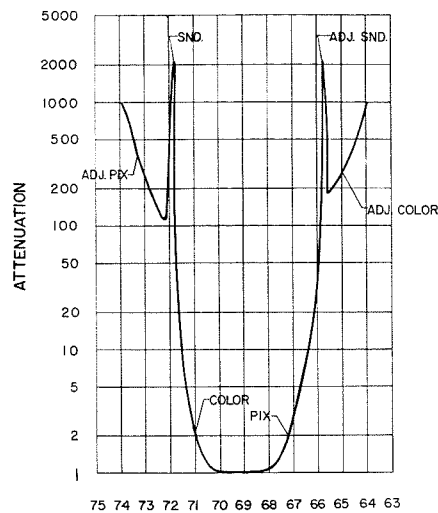
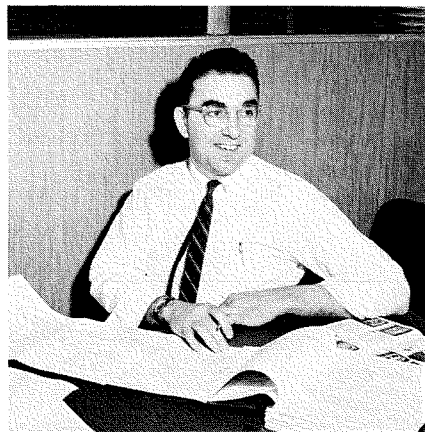

Fig. 3—Overall R-F/I-F selectivity to video detector.

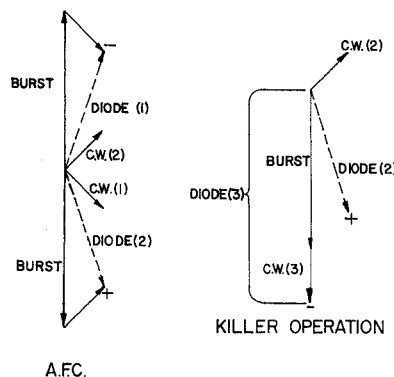

Fig. 4—Vector diagram—matrix.

#### CONCLUSIONS

This briefly describes the design of the unique sections of the "800M" series color television receiver. Our experience with this line has been very gratifying. Its performance under field conditions has maintained standards comparable to the best black-and-white receivers of the day.

Service problems have been negligible, being mostly confined to an occasional faulty tube or component.

**A. J. TORRE** received his B.S. in E.E. degree from the University of Oklahoma in 1943 and joined RCA Victor Division that same year. His early work at RCA was connected with the design and development of airborne radar equipment. Following the war, Mr. Torre transferred to the Home Instruments field, and engaged in design and development work on radio receivers. In 1950, he was a part of a newly formed group for Color Product Development, becoming manager of Electrical Engineering. In this activity, he has taken part

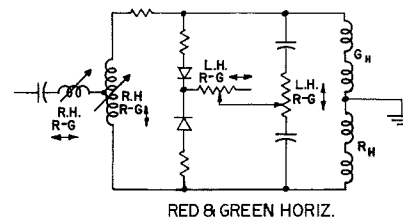
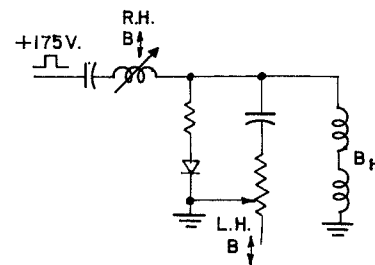
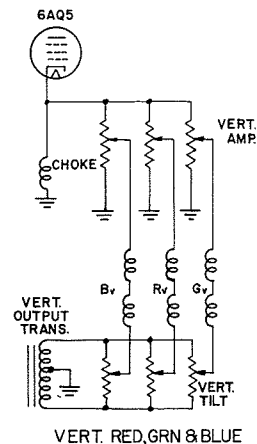

Fig. 5—Convergence circuitry.

There has been no recurrent service problem. Consequently, the 800 series enjoys a very favorable reputation in the service industry. Our servicing data puts this product in a category equal to current black-and-white television receivers.

#### ACKNOWLEDGEMENT

The author wishes to acknowledge the fact that the work carried on by the Color Television Department made possible the products described here.

in practically all field tests and demonstrations, as well as all commercial color television receiver developments including the most recent model, the "800M" Series. Recently, Mr. Torre's duties have been extended to include Product Acceptance & Planning for color television.

Mr. Torre is a member of Tau Beta Pi, Sigma Tau, Eta Kappa Nu, and a Senior Member of IRE. He is a Registered Engineer in the State of New Jersey, and holds 9 patents with an equal number pending.



# RCA ELECTRONICS GUIDE TWO

## NEW MOORE-McCORMACK LINERS

By

IRVING F. BYRNES

Communication Products Department  
(Radiomarine)

Industrial Electronic Products  
New York, N. Y.

TODAY THE CONSTRUCTION of a modern ocean liner is truly a special event, not only because a relatively small number of such vessels is required by the world's maritime nations, but because these highly specialized craft are so complex in design and structure. For example, in just the one area of communications services and modern aids to navigation, elaborate, custom-built electronic equipment must be developed to meet exacting government regulations and commercial requirements. Such marine equipment provides both challenge and opportunity for the electronics engineers who must produce the designs. This story deals with some of the contributions made by RCA engineers for this exciting field.

### THE BRASIL AND ARGENTINA

Two of the newest vessels that fly the United States flag are the *Brasil* and the *Argentina* of the Moore-McCormack Lines. Constructed by the Ingalls Shipbuilding Corporation, these sister ships ply the routes between New York and South American or European ports. Each vessel is 617 feet long, has a displacement tonnage of 22,590, a normal cruising speed of

21 knots, and accommodations for 535 passengers. Propulsion is by two geared turbines that develop 35,000 maximum horsepower.

Specifications issued by the electronics department of the Moore-McCormack Lines were based upon anticipated future needs as well as existing requirements.

For example, long-range single-sideband (SSB) and independent-sideband (ISB) radiotelephony are provided and these are the first U. S. flag ships to have such facilities. Operation with the conventional double-sideband system by carrier insertion in the SSB transmitter is also available for communications with coast stations that do not yet have single-sideband service. Long-distance radiotelegraphy is another essential requirement and must function simultaneously without mutual interference when the radiotelephone is in use.

### TYPES OF EQUIPMENT AND SERVICE

Shipboard electronic equipment may be classified broadly as "compulsory" or "voluntary" as determined by Government regulations or the requirements of the shipowner. Compulsory apparatus is primarily for

safety purposes, although it also has considerable utility in the day-by-day operation of the ship. Technical standards for such equipment are specified by the Federal Communications Commission or the U. S. Coast Guard. These Government agencies issue regulations that implement either international treaties to which the United States is a party, or Public Laws passed by the Congress. The technical standards cover minimum requirements in order to encompass many classes of smaller vessels that cannot afford a large installation. The *Brasil* and *Argentina* are equipped not only with compulsory apparatus that exceeds the minimum governmental requirements, but with many voluntary pieces of equipment as well. As a result, the ship radio station is capable of handling large volumes of radiotelephone and telegraph traffic and the deck officers have dual radars, loran and direction finders as navigational aids.

The major compulsory equipment on each vessel comprises a "main" radiotelegraph transmitter that delivers 1 kilowatt to the antenna for the 350 to 515-kc band, a 40-watt battery-powered emergency transmitter for the same band, two main receivers covering 80 kc to 30 mc in 18 bands, a 15-kc to 650 kc emergency receiver, a two-way radio in a motor lifeboat, a portable two-way lifeboat radio, radio direction finder and an automatic-alarm keying device.

Voluntary apparatus includes a 50-frequency 1-kilowatt peak envelope power output single and independent-sideband telephone transmitter for the 2-mc to 30-mc band, a similar 1-kilowatt transmitter but modified for CW telegraph service, an 85-watt double-sideband telephone transmitter/receiver for 20 channels in the 1.6-mc to 3-mc band, a 50-frequency remotely-controlled telephone receiver, a 3.2-cm radar, a 10-cm radar with chart room repeater and a direct reading loran.

Even on large vessels it is not possible to space the transmitting and receiving antennas so that the latter do not pick up several volts from the radiated signals. However, the receiving antennas are installed in the aft

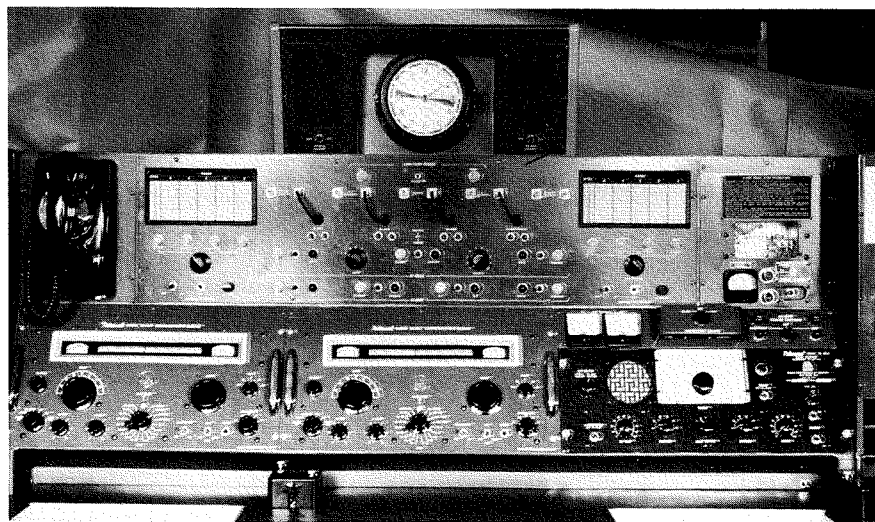

Fig. 1—Photo of the Radiotelegraph Operating Console which functions as a complete shipboard control center.



Fig. 2—In this view Niles Barlow, RCA Radiomarine Engineer, is shown at another control console arrangement that handles shipboard communication between SSB transmitter, remote receivers and the shipboard telephone switchboard.

section of the ship as the best compromise and the radiotelephone receivers, remotely controlled, are also in this area. The radiotelegraph receivers are in the main operating room, along with all transmitters, and the control consoles. One console provides two operating positions for telegraph, while a second console has one position for telephone.

In addition to the long-distance single-sideband telephone system, the double-sideband, 1.6-mc to 3-mc band phone is used by the ship's officers for medium range ship-to-ship or ship-to-shore communications. During periods of high traffic density there may be simultaneous operation on two telegraph channels, two independent sideband phone channels and on the DSB phone set, making a total of five two-way circuits.

The two radars, which have their indicator units installed in the wheelhouse, use 16-inch PPI tubes with six range scales from 1 mile to 40 miles. The X band or 3.2-cm radar antenna unit employs a 12-foot reflector giving a horizontal beam width of 0.65 degree. This radar, with its excellent bearing resolution, and a 0.25-microsecond pulse length on the shorter ranges is particularly useful in congested waters and for picking up small objects. The S band or 10-cm radar also has a 12-foot reflector for a 1.9-degree horizontal beam width at that frequency. Each radar indicator has a dichroic-mirror type reflection plotter

mounted over the scope so that the course and speed of other vessels may be directly plotted.

The chart room is equipped with a direct reading loran receiver-indicator, a goniometer-type fixed loop direction finder and a 16-inch PPI repeater for the 10-cm radar. These three facilities permit determination of ship's position at long, medium and short ranges. All three may be used at the same time when known objects are within radar and direction finder ranges and are to be cross checked with loran fixes.

Views of the operating consoles in the main radioroom are shown in Figs. 1 and 2. The larger of the two consoles for radiotelephony contains three communications receivers, an automatic alarm signal keyer, controls for the 1-kilowatt 350-to-515-kilocycle and the 1-kilowatt 2-to-30-mc radiotelegraph transmitters and controls for the 1.6-to-3-mc bridge radiotelephone. The two main receivers (AR-8516) cover a continuous range of 80 kc to 30 mc, divided into 18 bands, with crystal control in the high-frequency oscillator as part of a triple-conversion superheterodyne circuit. The third receiver tunes from 15 kc to 650 kc and is used for emergency purposes or for very-low-frequency reception.

The radiotelephone console functions as a control center between the single-sideband transmitter, the remote receivers and several lines to the ship's regular telephone switchboard.

There is also a separate radio telephone booth in the radioroom. Passengers may therefore place or receive calls from their staterooms or from the booth. The console includes a single-sideband converter and also hybrid amplifiers to connect the 4-wire radio circuits to the 2-wire telephone lines and has volume indicators (VU meters) to monitor the levels of incoming and outgoing speech. A privacy device is used to "scramble" outgoing and "unscramble" incoming signals for prevention of unauthorized reception. Additional privacy is also obtained with single-sideband service since the signals are not intelligible on conventional receivers.

#### ANTENNA DATA

For high-frequency transmission and reception, novel "trap" antennas are installed. The maritime telephone or telegraph services are assigned relatively narrow segments in the 4, 6, 8, 12, 16 and 23 mc bands. Advantage is taken of these assignments to reduce the number of separate antennas aboard ship. Traps for each band except the lowest (4 mc) are suspended along the antenna. The first section, cut to a quarter wave, terminates in a 22-mc trap. The second section, plus the first section, terminates in a 16-mc trap, and so on through the other traps. Thus, the antenna automatically becomes a longer quarter-wave section for the frequency selected. Since the traps are exposed to the weather and

build up considerable voltage they are sealed in epoxy resin cases and made strong enough to withstand the tensile strain in the antenna structure. The feed for each antenna is a 75-ohm coaxial cable connected to the lower end. Two high-frequency antennas are used for transmission, one for telephone and the other for telegraph. Similar antennas for reception are located in the aft section of the ship with supports between the exhaust stacks.

#### ADVANTAGES OF SINGLE-SIDEBAND SERVICE

The advantages of single-sideband radiotelephony for long-distance service have been known for some time.\* Until recently, however, technical and economic factors have restricted shipboard applications. In addition to spectrum conservation and greater freedom from interference, SSB provides intelligible speech circuits during most selective fading conditions. With double sideband, even high power often fails to offset the distortion that occurs when the two sidebands vary in amplitude or phase or when the carrier fades to such low levels that it does not properly demodulate the sidebands.

In the design of the 1-kilowatt transmitter for the new ships, advantage was taken of various new components that are now commercially available. Compact, efficient mechanical filters with a bandwidth of 3.2 kc for 6-db attenuation, and only 6.2 kc wide for 60-db attenuation are used. Two filters, centered at 250 kc, select the upper or lower sideband as desired, or both filters are left in the circuit and used with separate audio channels during independent sideband service. The carrier is suppressed in a balanced modulator controlled by a 250-kc crystal and is further suppressed by the mechanical filters.

Reception of single-sideband, carrier-suppressed speech signals requires that the carrier be reinserted in the receiver with an accuracy to the order of, say, 40 or 50 cycles. Although somewhat higher variations can be tolerated without undue distortion, the pitch of voice signals is raised or low-

ered, thus degrading their natural timbre. Generation of SSB emission in a transmitter of the type described involves cascaded stages of crystal-controlled balanced modulators. The crystals, in groups of 10, are operated in a temperature-controlled oven at 75°C plus or minus 0.5°. Maximum frequency variation is about 2 parts per million, equivalent to 44 cycles in the 22-mc band. On the lower bands, the variation becomes less, in a linear fashion, such as 16 cycles at 8 mc. Trimmer capacitors across each crystal are used for initial calibration or to correct long-term drift due to aging.

Most shore stations that handle ship-to-shore telephone service on single sideband utilize receivers with automatic frequency control. Therefore, such receivers can accommodate errors of a few hundred cycles in ship transmitters that radiate a pilot or control carrier. Provisions are made

in the 1-kilowatt transmitter to insert a carrier that is 20, 30 or 40 db below the PEP rating. However, looking forward to the time when "fully" suppressed carrier becomes the preferred system, carrier reduction by at least 50 db is also provided in the transmitter. One other mode, commonly called "full carrier" is also available. Here the carrier level is about 300 watts and this, with one sideband, is used occasionally with DSB shore stations or for tone signalling to alert SSB stations.

The power amplifier stage of the SSB transmitter uses one forced-air-cooled tube operating in class AB1 at a plate voltage of 2500. This tube is a pentode and has excellent linearity, resulting in attenuation of third or higher order distortion products by at least 35 db. Harmonics or subharmonics of the output frequency are attenuated 73 db. Automatic drive control for the power amplifier prevents

Fig. 3—View of the Radar Antennas and Direction Finder Loop installed on the liner, "Brasil."



\*H. F. Comfort, "Single Sideband Receivers," RCA ENGINEER, Vol. 3, No. 2 (Oct.-Nov., 1957) p. 50, and N. L. Barlow, "The Design of Single-Sideband Radio Communication Equipment," RCA ENGINEER, Vol. 1, No. 6 (Apr.-May, 1956) p. 14.

overdrive that otherwise could increase distortion and harmonics.

Excitation for the transmitter is obtained from any one of five exciter units, each of which covers a frequency ratio of about 1.7 to 1. With ten crystals in each exciter, a total of 50 frequencies are available. Exciters are pretuned to their required group of ten frequencies and include a solenoid-operated switch for remote operation from the control console. Since many of the marine bands are relatively narrow, frequency changes within such bands involve only local or remote rotation of the exciter switch. For greater frequency changes or shifts to another band, manual controls on the transmitter panel are used for exciter selection, driver tuning, PA tuning and PA loading.

Passenger vessels handle a large volume of radiotelegraph traffic in the 4-to-23-mc band and, under international regulations, this must be done on A1 emission, modulation being prohibited. The 1-kilowatt continuous-wave transmitter installed for this purpose is quite similar to the SSB transmitter previously described. Because telephony is not involved, the mechanical filters and audio circuits are omitted and the 250-kc oscillator is heterodyned "up" through the balanced modulators to the output frequency. However, in this c-w trans-

mitter, the linear power amplifier operated in class AB1 provides the high order of harmonic attenuation required in the marine service.

The remote receiver assembly, located in a separate room in the aft section of the ship is designed primarily for SSB service but is also capable of handling DSB signals. In either case, the final processing (sideband selection, detection, etc.) is accomplished by an adapter unit in the radioroom telephone console. Therefore, the output of the remote receivers is at an intermediate frequency of 455 kc and this amplifier is part of a double-conversion superheterodyne circuit as described below.

#### TECHNICAL INFORMATION

Five separate r-f amplifiers provide coverage of the 4, 8, 13, 17 and 22-mc bands that are used for transmission from coast stations to ships in the high seas services. Each amplifier has one r-f stage, a mixer and a crystal-controlled oscillator. A pair of tuned circuits in the r-f grid circuit and a second pair in the plate circuit restrict cross modulation and blocking from the nearby transmitter antennas. Signal-to-noise ratio is sacrificed moderately in favor of r-f selectivity. For signal-to-noise ratio of 6 db about 2.5 microvolts input is required. The mixer stage in the r-f amplifier deliv-



**IRVING F. BYRNES** has been associated with RCA since 1930. Mr. Byrnes has held important posts in RCA including Vice President, Engineering, Radiomarine Corp. of America. He entered the General Electric Test Department in 1918 and was later engaged in radio development in the Engineering Laboratory. He completed extension courses in Electrical Engineering at Union College, and in 1922 participated in the development and design of early ship-to-shore radiotelephone equipment. He has been granted several U. S. patents for radio devices, and in 1940 he received the Modern Pioneers Award from the National Association of Manufacturers for his contributions in the art of marine radio communication. The U. S. Navy Bureau of Ships awarded Mr. Byrnes its Certificate of Commendation in 1947. He is the author of many technical papers on radio equipment, and is a Fellow of IRE. Mr. Byrnes is a member of "RCA Review," Board of Editors and the RCA Institutes Board of Technical Advisors.

Fig. 4—Radar Repeater, Loran, and Direction Finder installed in the Brasil's chart room.

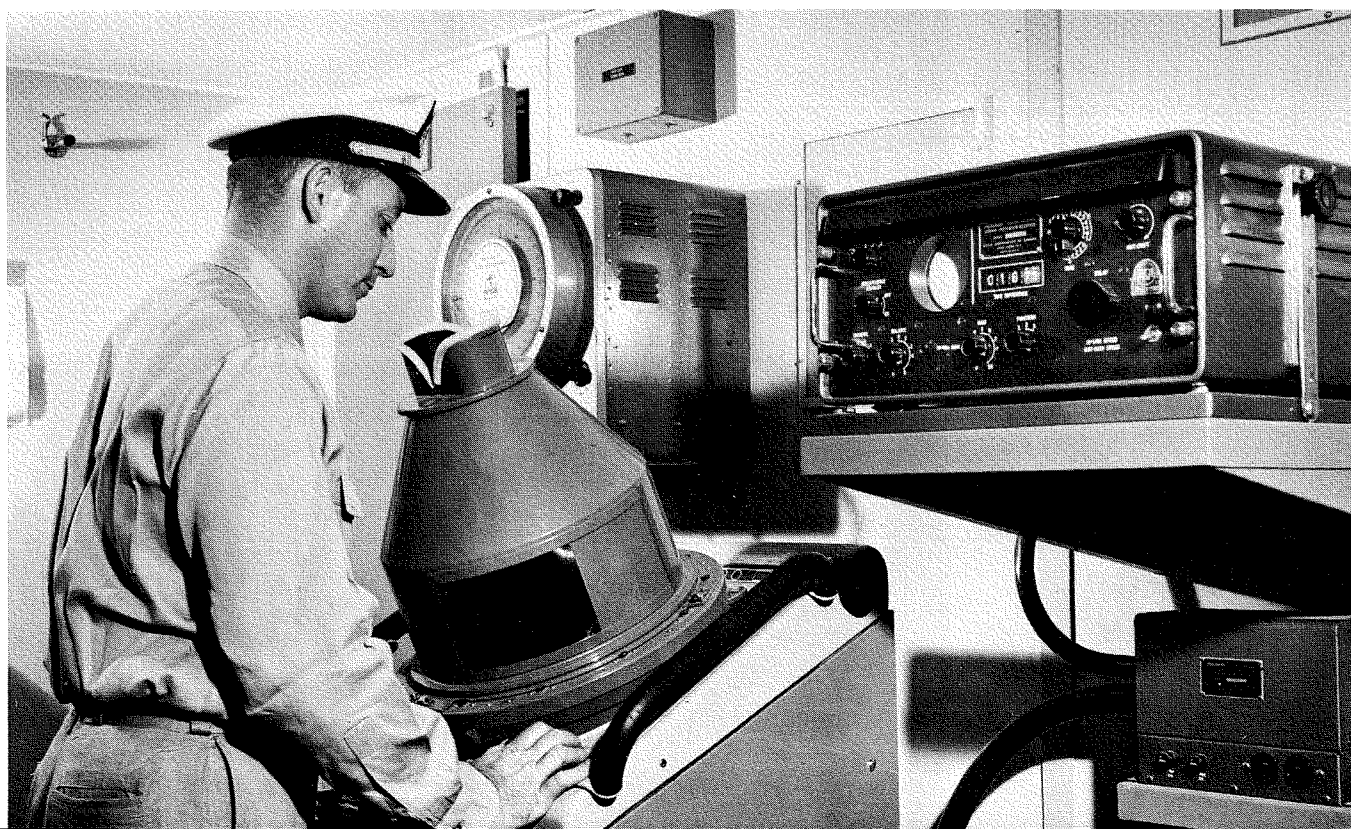



ers an intermediate frequency at 3 mc. This high i-f, in conjunction with the four tuned circuits at the incoming signal frequency, gives an image and i-f "feed-through" rejection of at least 90 db. Each r-f amplifier has ten temperature-controlled crystals that maintain the first oscillator within 2 parts per million cycles and a 10-position motor-driven frequency selector switch. Each frequency is pre-tuned and since there are five amplifiers any one of 50 pre-tuned frequencies may be remotely selected from the main radioroom. Local control at the receiver assembly is also provided for routine maintenance purposes.

The 3-mc output of the particular r-f amplifier selected is then automatically switched to a "common" i-f amplifier. This i-f unit includes a 3-mc amplifier, a mixer, a 2545-kc crystal-controlled oscillator and three stages of 455-kc amplifiers. A crystal roofing-type filter, centered at 455 kc, is connected between the output of the mixer and the grid of the first 455-kc stage. The 6-db bandwidth of the crystal filter is 9 kc in order to pass DSB as well as SSB signals. Bandwidth for 80 db rejection is only 19 kc, most of which is due to the crystal filter. The third or last 455-kc stage is coupled to a cathode follower and also to a "local" monitoring detector and audio amplifier. The cathode follower delivers its output at a level of 200 millivolts to a 75-ohm coaxial cable whose far end connects to the adapter unit in the radioroom. An a-g-c rectifier and noise limiter are also provided. However, during normal remote control operation, a-g-c voltage is derived from the adapter unit because the latter, on SSB, must develop this voltage from the sideband energy.

A power-supply unit furnishes regulated plate and bias voltage for all tubes in the receiver assembly. Series regulator tubes, controlled by a feedback amplifier through a glow discharge voltage reference diode, maintain plate voltage within one per cent. Thirty-three tubes are used in the complete receiver assembly, including those in the power supply but not those in the adapter unit.

#### THE TELEPHONE CONSOLE

The telephone console includes a special converter unit that permits selection of the upper, lower or both sidebands and has two i-f and audio output circuits for independent sideband operation. The 455-kc signal is converted to 100 kc in this unit and crystal filters are employed for sideband selection and a-f-c control of a pilot carrier when the latter is transmitted by the shore stations. The carrier filter is 20 cycles wide and is used in a discriminator circuit to derive error voltages so that the a-f-c circuit will hold the local oscillator to within 5 cycles. For suppressed carrier signals, the converter unit a-f-c circuits are replaced by a crystal-controlled oscillator that may be adjusted over a narrow range with a front panel control. Automatic gain control is applied by the converter to its own circuitry and also to the remote receivers, using fast attack and slow decay during sideband operation.

Since the remote receivers are crystal controlled, they are pretuned for the known frequencies of the principal coastal telephone stations. To provide increased flexibility when operating with any station, the console also has a tunable receiver, for the 80-kc to 30-mc band. This receiver also functions as a general monitoring and emergency unit.

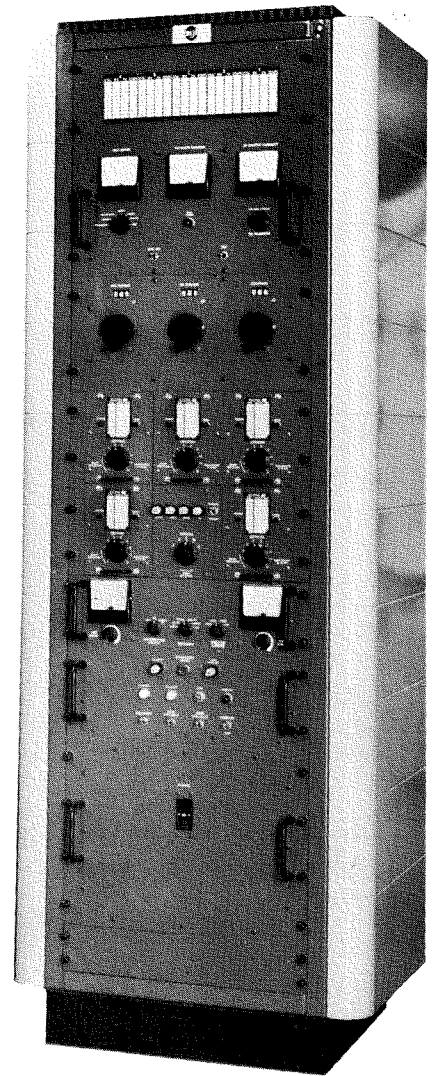

Fig. 5—The rack-mounted, 1000-watt independent sideband transmitter.

Fig. 6—View of the "Brasil" in the Rio De Janeiro harbor with Sugar Loaf Mountain in the background.





# PAGE-RCA PACIFIC SCATTER COMMUNICATIONS SYSTEM

By

R. W. CONNER, R. S. LAWTON and M. C. MYERS

Surface Communications Engineering

Defense Electronic Products

Camden, New Jersey

THE PACIFIC SCATTER Communications System will be placed in service during the second and third quarters of 1959 to provide telegraphic and voice facilities for the joint U. S. Defense Services in the Pacific employing Ionospheric scatter transmission. It is the largest system of this type built to date. The system is comprised of two terminals and six relay stations plus intra-site equipment. Distances between relay stations vary

## THE SYSTEM EQUIPMENT

The equipment supplied by RCA for this installation differs from earlier Ionospheric systems installed by Page in that all items of equipment were redesigned to pass environmental test, whereas earlier systems had employed modified versions of commercially available equipment, not subjected to environmental tests.

Typical of environmental requirements for these equipments is opera-

ment, Tropospheric Transmitters and Receivers, Frequency Shift Keying Equipment, Transmit/Receive Duplexers, Voice Frequency Terminal Equipments, Intra-site Transmit/Receive Units, and Test Equipment. Typical of the quantities required were twenty-nine 50-kw transmitters and twenty-six 16-Channel Time Division Multiplex Equipments.

## A PROJECT ENGINEERING JOB

Project Engineering was given responsibility for the coordination of Surface Communications, overall effort. The project engineering team formed to execute this contract required the skills of several activities within the Surface Communications Department, such as the Equipment Engineering in Camden and the Product Design and Development Engineering Group in New York City.

Fig. 1 is an organizational chart showing the project engineering group by function and its relation to Marketing and other departments within RCA. Of the total equipments supplied by RCA, under this contract, approximately 40% were subcontracted to outside suppliers and 60% was manufactured by RCA. Subcontracted equipments such as the Frequency Shift Keying Equipments were redesigned, built and tested under Surface Communications Engineering Supervision. This necessitated close engineering coordination with the several subcontractors shown in the chart of Fig. 1. The equipments manufactured by RCA (representing 60% of the total) were also redesigned by Surface Communications Equipment Engineering. These items were produced by IEP manufacturing facilities in Camden and New York.

The 50-kw Ionospheric Transmitter and 16-Channel Time Division Multiplexer were two of the more complex equipments built by RCA. These equipments were built to Rixon-Lincoln Laboratory Designs, previously produced by another manufacturer in model shop quantities, and are now in service. Field reports dictated the need for more rigid specifications and complete environmental tests. Further, JAN components were required to pass environmental tests

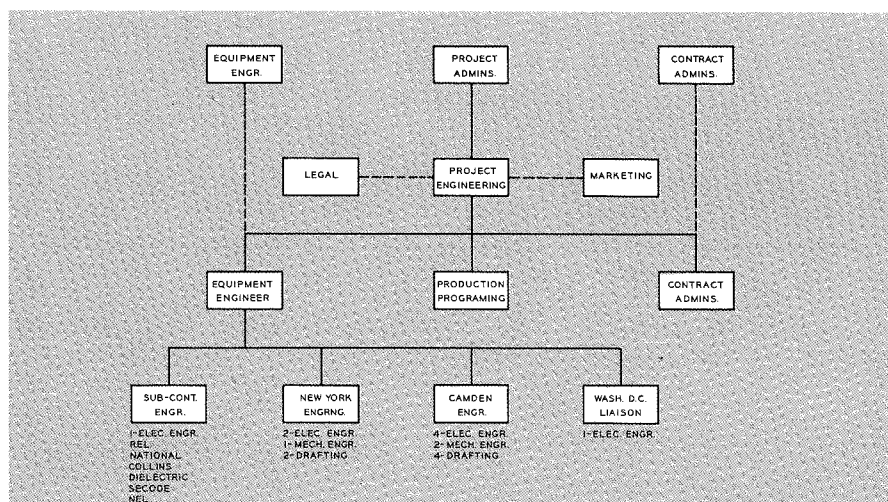

Fig. 1—Block diagram showing the Pacific Scatter Communications Project Engineering setup and lines of contact.

from approximately 800 to 1200 miles with the total length exceeding 7,000 miles.

Early in 1957, Page Communications Engineers received "Notice of Award" from the Signal Corps and later awarded RCA a "Letter of Intent" to supply all basic items of electronic equipment on a "short-term" basis. The shorter and tighter time schedules are a result of today's rapidly expanding needs for highly reliable communication facilities by our defense forces.

This article will describe how RCA's Surface Communications Project Engineering group organized and performed to meet this challenge from "Letter of Intent," to paper designs, and to delivery of equipment.

tion at temperatures from 0°C to 50°C, and non-operation (storage) at -54°C to 74°C; barometric pressures from 24 to 30 inches of mercury operating; and 4 to 30 inches of mercury non-operating. The equipment was also required to perform with humidities up to 100%.

The basic items of electronic equipment supplied by RCA included twenty-six different types in varying degrees of size, complexity and quantities. Some of the more important items are as follows: 50-kw (32- to 60-mc range) Ionospheric Transmitters, 16-Channel Time Division Multiplex, FM Receivers, Excitation Control Panels, Dual Diversity Receiving Adapters, Preamplifiers and Distribution Systems, Voice Exciter Equip-

### DESIGN AND PRODUCTION TIMETABLE

JAN.	Notice of Award
FEB.	Letter of Intent Commence Engr. Release Dwgs. & Bm.
MAR.	Commence Contract Definition
APR.	Received Revised Specifications
MAY	
JUNE	
1957	
JULY	
AUG.	Notice of Change in Scope for Quick Freq. Change
SEPT.	
OCT.	
NOV.	Definitize Quick Freq. Change
DEC.	Complete Contract Definition— Complete Release Dwgs. & Bm.
JAN.	Commence Factory Final Assembly
FEB.	
MAR.	
APR.	
MAY	Commence Production Test 10 KW
JUNE	
1958	
JULY	Commence Production Test 50 KW
AUG.	Complete Prod. Tst. 10 KW—Commence Shipments 10 KW Portion
SEPT.	Begin Environmental Test 50 KW
OCT.	Engr. Sign-Off
NOV.	Complete Environmental Test
DEC.	Received Approval of Environmental Test Data—Commence 50 KW Shipments
1959	
MAR.	Complete All Shipments

Fig. 2—Timetable showing the Release and Production Cycles for the 50-kw Ionospheric Transmitter.

in all cases consistent with the delivery schedule and, where this was not possible, high quality commercial components meeting equivalent specifications were substituted.

#### TIMING OF DELIVERY CYCLES

Fig. 2 shows graphically the steps taken and the time cycle for the delivery of Ionospheric Transmitters. To meet the accelerated time cycle and for economic reasons it was decided to produce the transmitters without building a model.

To redesign and modify the System Equipment to meet more stringent environmental conditions, and to accomplish this on time without benefit

of an engineering prototype introduced some interesting and challenging design problems.

For example, to meet production schedules, engineering releases of all long-lead items were frozen designwise and given to Purchasing upon receipt of the "Letter of Intent." These included electronic components, cabinets, and as much hardware as possible. This procedure called for engineering decisions based on the experience of the project group and consulting advice from cooperating engineering activities, rather than to employ rigorous engineering and laboratory tests prior to release.

The flow chart (Fig. 2) shows that detail specifications were negotiated with the customer during several months into the procurement cycle. Moreover, after approximately five months of the cycle had elapsed the customer requested a "Change in Scope" which involved further redesign of each stage for "Quick Frequency Change." Formerly, adjusting the transmitter to a new carrier frequency required 8 or more manhours. The redesign permits frequency change in fifteen minutes.

Certain of the electrical designs could not be frozen until the first production unit went into test. This necessarily increased the time in test and caused an accelerated engineering effort during this period, with perhaps a greater number of ECN's than would be normal.

The performance of the final equip-

ments together with the large savings in time and money we feel justifies the approach used in this case.

#### 50-KW IONOSPHERIC TRANSMITTER

Fig. 3 shows a picture of the STV 60 transmitter which consists basically of a 10-kw transmitter and 50-kw amplifier. The 10-kw portion has a separate power supply and may be operated independently of the 50-kw amplifier in emergencies. The system reliability is specified at 99%. To achieve this, the transmitters are installed in pairs and arranged for "Fail Safe" operation. That is, in normal operation one transmitter carries a voice channel and the other carries sixteen teletype channels 24 hours a day, 7 days a week. For maintenance periods or in event of failure, either transmitter may be adjusted for linear operation and then transmits both the voice channel and the sixteen teletype channels at a power of 40-kw PEP. The carrier frequency may be anywhere in the range of 32 to 60 mc. Modulation may be Amplitude, Single Sideband, Frequency, Phase or Frequency Shift Keying. Environmental specifications require operation from 0° to 50°C. relative humidity to 100% and alti-

Fig. 3—STV 60 Ionospheric Transmitter—Shown in the picture is R. S. Lawton (left), Equipment Engineering Leader responsible for redesign and engineering release on all items of equipment. Also shown in the picture is Gene Watts (right), engineer who participated in environmental testing of the transmitter.

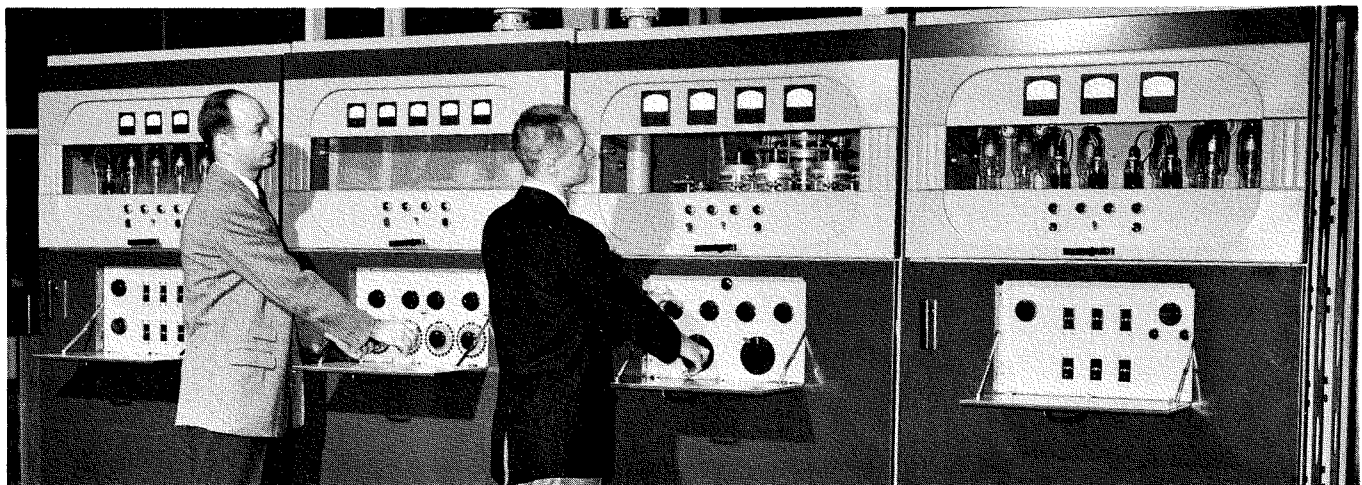

#### CONTRIBUTING ENGINEERS

##### SurfCom, Camden

N. I. Klavens, Elec. Engr.  
H. W. Leidy, Mech. Engr.  
A. E. Lemberg, Elec. Engr.

M. Slobins, Mech. Engr.  
E. R. V. Watts, Elec. Engr.  
G. Wild, Elec. Engr.

##### SurfCom, New York

A. Canfora, Elec. Engr.  
W. E. Roake, Elec. Engr.  
L. Spann, Elec. Engr.

J. Trupiano, Mech. Engr.  
R. N. Van Delft, Elec. Engr.  
C. Wohl, Elec. Engr.

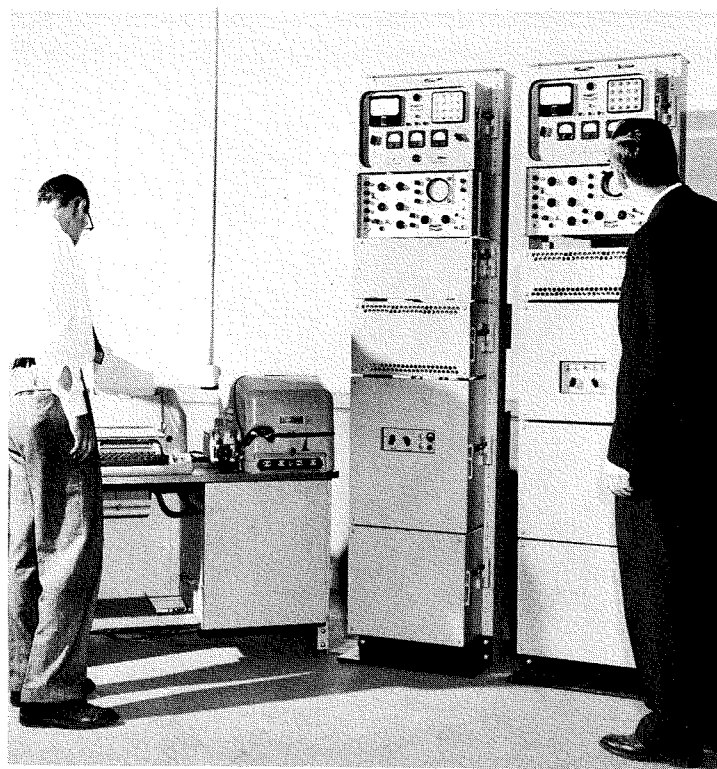

Fig. 4—16 Channel Teletype Multiplex Terminal Equipment Transmitter and Receiver. Shown in the picture are C. Wohl, project engineer, and M. Myers, New York SurfCom Engineering Manager.

tudes from sea level to 6000 feet on primary supplies of 230 volts, plus or minus 10%.

#### TELETYPE MULTIPLEX EQUIPMENT

Another interesting equipment produced on this contract is the teletype multiplex equipment. This equipment was engineered and supervised through production by Surface Communications Engineering in New York. The methods described for the transmitter above were also followed in this case. We believe this equipment is unique in its field and will be of interest to engineers working with transistors in other applications.

The Telegraph Terminal ES-8888 is a 16-Channel Time Division transistorized teleprinter multiplexer (MUX), utilizing plug-in encapsulated magnetic memory core storage units. It consists of a Transmitter and Receiver, each contained in a standard 19" relay rack, 7 feet high. All chassis are mounted in hinged modules, allowing access to both sides of the chassis.

The equipment handles standard 7.42 unit teleprinter codes at 60, 67, 75 or 100 words per minute. The transmitter receives information in parallel from up to 16 teleprinters,

Fig. 5—Teletype Multiplex Terminal opened to show modular construction. Shown in the picture is J. Trupiano, mechanical engineer responsible for mechanical design of the unit.

each sending an individual message, all at the same speed.

The information is stored in the MUX and then delivered serially at a higher speed such that the time for the transmission from the MUX of 16 characters, one from each of the 16 input channels, is approximately equal to the time of one character from the teleprinter. The MUX transmission speed will therefore be approximately 16 times faster than the teleprinter speed. This information is transmitted to the MUX Receiver, via land lines or radio, where the

serial information is again stored, and fed out in parallel, at teleprinter speed, to each of the 16 teleprinters.

#### MULTIPLEX STABILITY

Both the Transmitter and Receiver contain extremely accurate crystal oscillators, with a stability of better than 1 part in one-hundred million per day, which provides the timing pulses for the system. The Receiver oscillator is kept in synchronization with that of the Transmitter by means of an AFC circuit in the Receiver, which senses the reversals in the MUX signal. By comparing these reversals, which are a function of the frequency

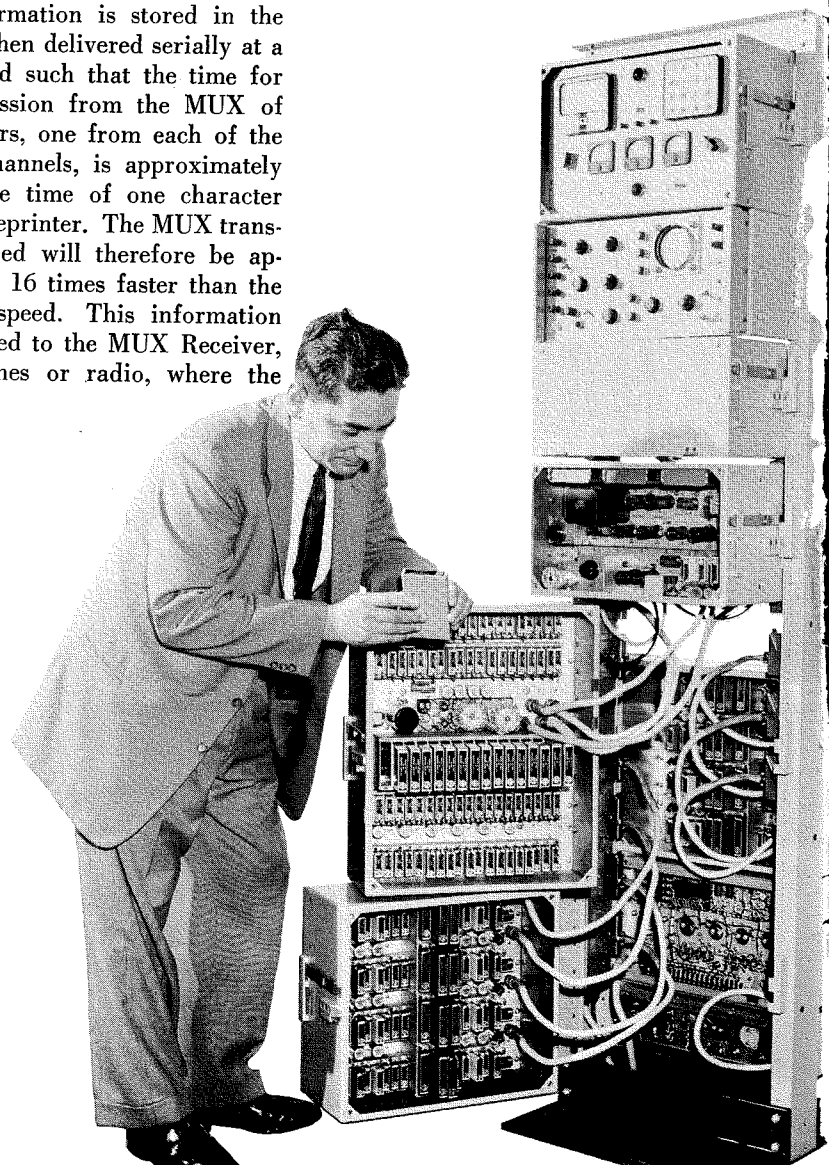

of the Transmitter oscillator, with the timing pulses generated in the Receiver, the Receiver oscillator is kept in phase with and at the same frequency as the Transmitter. This synchronization prevents the possibility of the Receiver sensing a pulse at the wrong time.

A second type of synchronization is also provided. This assures that each frame of 16 characters will be handled as one group while being operated upon by the MUX, thereby insuring the reception at each teleprinter of the correct message. This frame synchronization is accomplished automatically by a specially coded pattern generated in the Transmitter, which the Receiver uses to maintain frame synchronization. If for some reason these frame synchronizing patterns are not received by the Receiver, an alarm lamp is lit. However, to make sure that these missed sync patterns, or groups, are actually the result of some continuing fault, rather than an isolated one, the circuitry is arranged so that the alarm will not be triggered until some selected number, up to seven, of these groups are not received. The synchronizing groups are sent at pre-determined intervals, so that the Receiver is "aware" of the absence of these patterns if they are either not received or if the code is incorrect.

While every effort has been made to achieve long term reliability, the transistors, diodes and magnetic cores have been encapsulated in replaceable modules, allowing easy replacement of faulty components. The equipment will operate over a voltage range of 92 to 138 volts, 47.5 to 63 cps, ambient temperature  $-19^{\circ}\text{C}$  to  $+54^{\circ}\text{C}$ , and relative humidity up to 100%.

#### PRODUCTION RELEASE

The engineering problems involved in redesign, product design and pro-

**ROBERT W. CONNER** attended the University of Wisconsin from 1930 to 1935 studying Electrical Engineering and majoring in Wire and Radio Communications. In 1935 he joined the Peoria Broadcasting Company to design and supervise the construction of two radio stations. In 1942 he joined RCA as a radar field engineer and worked on Airborne, Shipboard and Submarine radar throughout the war. After the war he transferred to Television Broadcast Field Engineering and in 1949 received the RCA Merit Award for his work in

duction were increased because circuit refinements could not be frozen until the first production unit was tested. This was particularly so with the MUX equipment since each Transmit/Receive unit employs several thousand transistors, diodes and memory cores all required to perform error-free over wide voltage, frequency and temperature limits. Final refinement and redesign of these circuits during environmental testing caused the test cycle to extend over 60 days. Although some 35 design changes were required during environmental test and some scrappage was involved, the time and money saved in the overall program would seem to justify this method. One of the specification requirements was for each equipment to operate error-free continuously for 72 hours and that during 4 hours of this test the ambient temperature be raised to  $54^{\circ}\text{C}$ . Further, each module of a type must be interchangeable with any other similar module in the system. Those engineers familiar with transistors and memory cores will surely appreciate the type of circuit refinement required of engineering to meet these specifications.

Many of these equipments have now been in operation for several months and customer field reports describe installation and operation problems as minor, which further justifies the methods used.

#### ACKNOWLEDGMENTS

To produce equipments as complex as the transmitter and multiplex, by the method described, required best efforts and very close cooperation between Marketing, Engineering, Purchasing, Manufacturing, Quality Control, and our customer. Happily, these necessary ingredients existed throughout the program. We are also indebted to the Broadcast Engineering Group for valuable suggestions.

this field. In 1953 he became Manager, Broadcast Installation and Customer Service Department, and in 1955 he became Chief Engineer for RCA's manufacturing facilities in Sao Paulo, Brazil. Returning to the U. S. in 1957, he joined Surface Communications Project Engineering and is presently responsible for project engineering on the RCA-Page Ionospheric Communication System. Mr. Conner is a member of IRE and a registered Professional Engineer in the State of California.

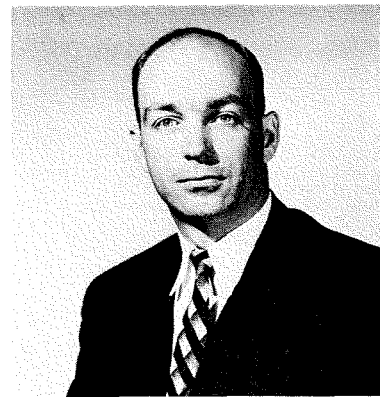

**ROBERT S. LAWTON** received a B.S. Degree in Electrical Engineering from Kansas State College in 1951 and an M.S. in Electrical Engineering from Drexel Institute of Technology in 1956. He joined RCA in 1951 as a Specialized Trainee and became a member of the Surface Communications Section engaged in the design of communications and navigation equipment. In 1957, Mr. Lawton became an Engineering Leader in the Long Range Communication Equipment Group with responsibilities in high power transmitter design. He is a member of Eta Kappa Nu, Sigma Tau, Phi Kappa Phi and the IRE.



**MELVIN C. MYERS** received a B.S. Degree in Physics from Yale University in 1942. Following graduation Mr. Myers joined the M.I.T. Radiation Laboratory as a staff member and participated in research and development work in microwave radar.

At the end of the war Mr. Myers joined the RCA Radiomarine Division in New York where he was engaged in development of commercial marine radar and other marine electronic equipment.

In 1956 he was transferred to the Surface Communications Department of DEP and he is presently Manager of the Product Design and Development Group in the New York Systems Laboratory.





by  
**C. W. STEEG, JR. and F. A. BARNES**  
*Missile Electronics & Controls Dept.*  
*Defense Electronic Products*  
*Burlington, Mass.*

**T**HE SUCCESSFUL DEVELOPMENT of a major weapon system today, which may incorporate an airframe similar to that of the X-15 pictured in Figure 1, requires the solution of problems spanning so many fields of technology that it becomes necessary to acquire some skills and knowledge that seem, at first glance, unrelated to RCA's electronic products line (radar, communication, TV, digital data processing, etc.). Aircraft flight control

which the airframe can be controlled to fly the prescribed path in the presence of atmospheric turbulence and interference noise often determines the precision and accuracy with which the mission can be completed (e.g., the accuracy with which the weapons can be launched or guided). If the aircraft is inhabited, then the degree of flight-control automaticity may determine how free the human operator is to apply his unique powers of judgment to the handling of unforeseen situations that could otherwise defeat the mission.

Second, the size, weight and complexity of today's weapon systems have not been permitted to increase

uct line in the future should not be overlooked. As new flight-control concepts are developed through increased responsibility in this field, the more active the RCA role in bringing about these developments, the more beneficial they will be in the form of new products.

For these and other reasons, the responsibility for analysis and synthesis of the overall weapon system must continue to include not only active but also increased responsibility for flight control even when substantial help from a flight-control subcontractor is also required. Moreover, just as synthesis of the flight-control system is an inseparable part of the overall

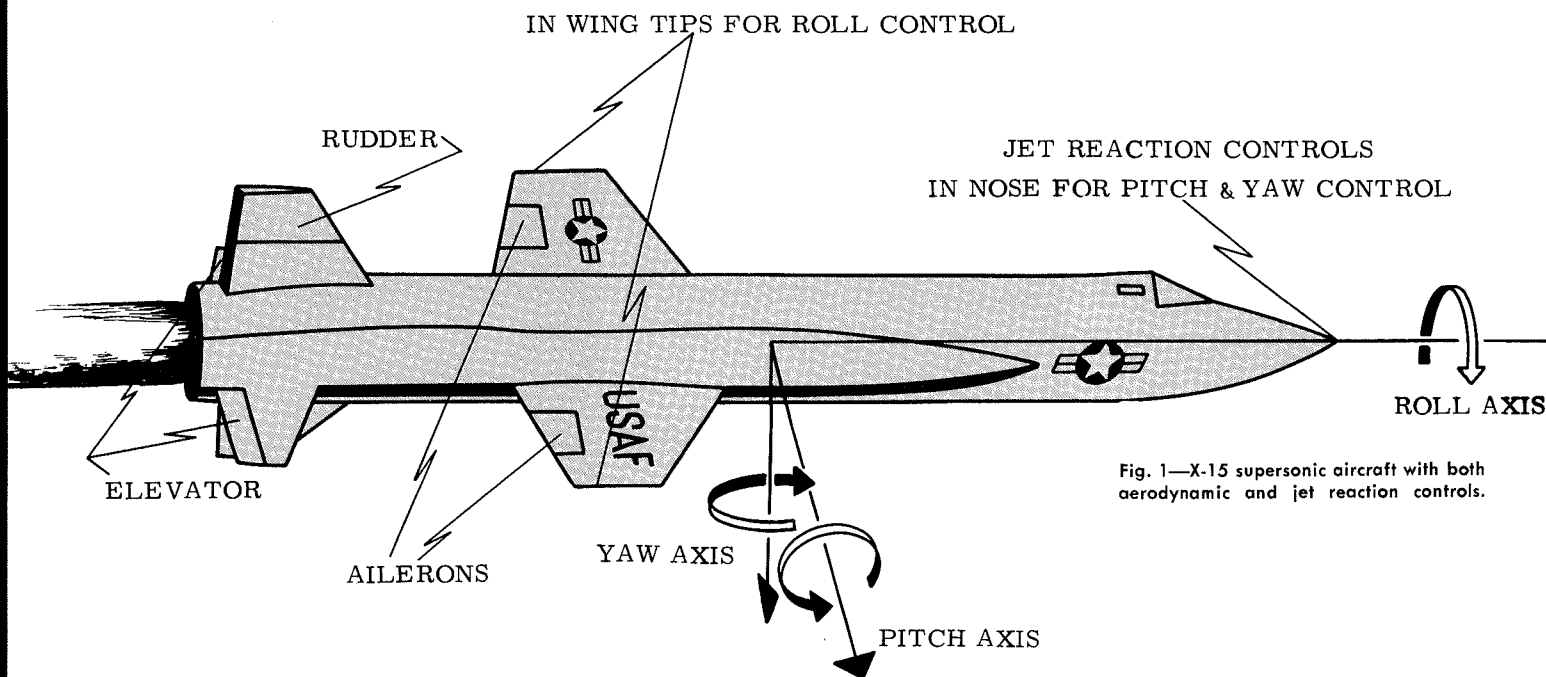

Fig. 1—X-15 supersonic aircraft with both aerodynamic and jet reaction controls.

synthesis is such a skill inasmuch as autopilots, stability augmenters, and similar controls are not at present being manufactured by RCA. However, the flight control process recently has become so basic to most weapon systems and often so vitally related to other system processes (e.g., fire control, navigation, system checkout, etc.) that the system engineering responsibility for flight control should not be separated from that for the overall system for several reasons:

**BASIC FACTORS**

First, the quality of flight control may directly affect the probability of mission success. Whether the aircraft is inhabited or not, the success with

in proportion to the complexity of the mission because of the equipment reliability problem and other practical limitations. Hence, the various equipments have had to be shared (consolidated) among the various system processes to a far greater extent than ever before. Examples where significant consolidation has resulted are in the centralization of functions such as computation, geometric reference, and power supply. Thus flight control is not only a basic process to any weapon system but it tends to be inextricably interwoven with the other processes (as illustrated in Fig. 2) for a typical modern fighter-bomber.

Third, the possibility of adding flight-control equipments to our prod-

uct system synthesis responsibility, so should the selection of suitable airframe characteristics be a flight-control system synthesis responsibility. In other words, ideally, no component part of the overall system (other than the human operator) should have to be considered immutable in the synthesis procedure. Unfortunately, expediency sometimes dictates to the contrary.

**THE FLIGHT CONTROL PROCESS**

Traditionally, the term "automatic pilot" or "autopilot" referred to those equipments (gyros, amplifiers, power actuators, etc.) which when added to the airframe made a closed feedback loop capable of automatically holding



the aircraft on a given heading or at a given altitude or both. When an aircraft was flying with such an autopilot engaged, the pilot could change the angular orientation of the aircraft by disengaging the autopilot while changes were being made, or, when only small corrections were required, he could make the corrections by use of turn and trim adjustments. Hence, an autopilot was used to provide limited orientational control, but, was quite unsuited for the maneuverability requirements of most military aircraft. As the speeds, altitudes, and maneuverability of military aircraft increased subsequent to World War II, poorer airframe stability and damping resulted. This aircraft performance required the addition of such closed-loop pilot aids as automatic pitch and yaw dampers and stability augmenters. Such devices were often necessary,

in pitch, roll, and yaw, but also to accept commands for all-attitude maneuvers. For inhabited aircraft, the latter required banking the aircraft as needed for turns while simultaneously coordinating the rudder motions so as to prevent the occurrence of sideslip. This expanded collection of equipments: couplers, autopilot, airframe controllers and airframe, (i.e., the entire closed-loop system transforming flight control commands into controlled aircraft motion), was designated a flight-control system. However, as already pointed out in connection with Fig. 2 a flight-control system today is not necessarily a distinct collection of equipments inasmuch as these equipments are often shared. But, flight control is a process distinct from the other processes and may be so labeled whenever ambiguity would otherwise arise.

In order to predict the stability and control characteristics as early in the developmental program as possible and certainly as far ahead of actual flight test as possible, the flight-control system engineer may construct a laboratory mock-up of the entire flight-control system such as the one shown in Fig. 3. With such a mock-up, experiments involving human operators can be conducted corresponding to any or all phases of the weapon-system mission and simulating flight conditions that cover the full range of aircraft performance characteristics. By such simulation, the suitability of the proposed flight-control process can be thoroughly evaluated under realistic tactical situations and its operation with other component systems can be checked. All this can be done early enough to permit inexpensive design changes, if needed. Furthermore, thor-

## SYNTHESIS OF AUTOMATIC FLIGHT CONTROL SYSTEMS

in fact, just to make these aircraft manageable under manual control. Furthermore, the control surfaces on these newer aircraft were either power boosted or fully power operated, so that an auxiliary so-called "artificial-feel system" was often incorporated to apply force to the control stick in a manner which suited the conditioned responses of experienced pilots, thereby, producing more or less standard handling qualities in these aircraft.

As further automaticity became necessary, autopilots were redesigned appreciably so they could accept steering commands corresponding to the full range of maneuverability required. Flight-control couplers were designed to generate appropriate steering signals from the outputs of many devices. In this way flight control was coupled to the ILS (instrument landing system) receiver, to the ground data link, to direction finding and other navigational equipments, and to the weapon delivery system (for automatic attack steering). The autopilot task was then not only to stabilize the aircraft

### THE SYNTHESIS PROCEDURE

The principal functions of an aircraft or missile flight control system are: 1) to assist in maintaining the airframe in a prescribed flight condition despite transient disturbances, such as wind gusts, and 2) to change either the orientation or flight-path direction when commanded. The first function is associated with the *stability* of the vehicle and the latter with its *control*. Successful synthesis of a flight-control system demands that the design engineer consider both the stability and control of the overall system. His job is to select airframe characteristics, controllers, aerodynamic surfaces, spoilers, reaction jets, actuators, sensors, and signal modifying networks. Thus the stability and control characteristics of the flight-control system, which may contain the pilot as an immutable element, satisfy a performance criterion appropriate to the overall weapon system. The flight-control synthesis procedure is therefore one of combining the appropriate elements into an acceptable unified whole.

ough simulator evaluation permits the number of flight tests to be minimized.\* In fact, the role of flight testing then becomes mostly one of verifying or spot-checking the validity of the simulator tests.

Analysis of control problems precedes the design of the mock-up and is a major part of the synthesis procedure. Any element may be subjected to control if three conditions are met. First, the required changes must be controllable or regulated by some physical means, in these cases by such devices as control surfaces, spoilers, and reaction jets. Second, the controlled quantities must be measurable, or at least comparable to certain reference or standard quantities; that is, there must be sensing or measuring devices which, for flight control, are usually accelerometers, gyros, barometers, vanes, and probes. Third, both regulation and measurement must be sufficiently rapid for the job and,

\*See "The Analog Computer in the Design of Complex Systems," RCA Engineer for December 1958-January 1959.

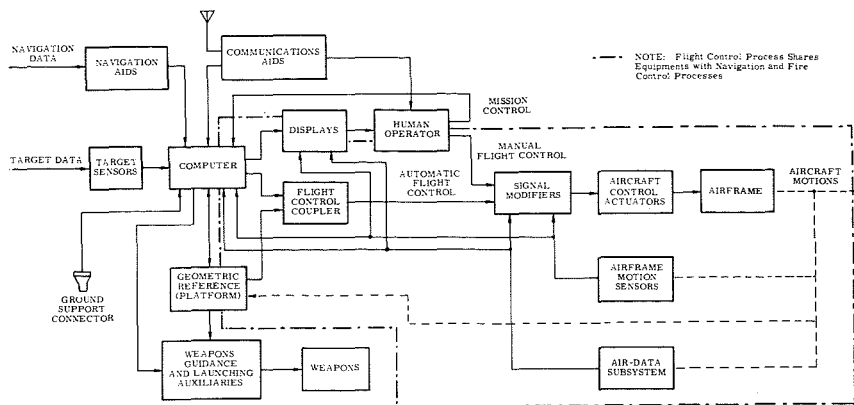

Fig. 2—Functional diagram of overall weapon system typical of fighter-bomber.

preferably, involve negligible dynamics. These conditions lead to the first two steps in the synthesis procedure; namely, selection of control means, actuators and choice of sensors. The third and most essential step is termed equalization, and includes all the means required to interconnect and modify the performance of any system operation. In flight control, the airframe may have to be accepted without change because certain design parameters affecting its performance are determined by factors other than controllability, such as landing speed, structural rigidity, and maximum takeoff weight. Sensing and actuating elements are semi-immutable, in the sense that they can be changed only by selection of a different member of the same general class. Equalization elements, on the other hand, are free to be chosen or designed within broad limitations of physical realizability and practicability. Consequently, the bulk of the analysis is concerned with the determination of the equalization elements of a mechanism required to control the airframe in accordance with a prescribed performance criterion.

The analysis procedure makes frequent use of standard control system

engineering methods such as 1) the methods of frequency analysis developed by such authors as Hall, Nichols, and Evans to determine stability of closed-loop dynamical systems and to guarantee a reasonable margin of stability over the range of operating conditions, 2) the methods of statistical analysis developed by Weiner and others to estimate the effects on closed-loop systems of random interference inputs from wind gusts and from various noise sources, and 3) analog and digital computation permitting quantitative study of the system's response to command inputs and to the various interfering inputs.

#### TWO CONTRASTING TYPES OF PITCH CONTROL

Ever since July, 1914, when Lawrence Sperry used an autopilot to guide an aircraft over a reviewing stand in Paris, France, it has been difficult to distinguish progress in general control systems theory from advancements in automatic flight control. In exercising his choice of motion sensitive elements, the design engineer can develop a wide variety of flight-control systems. Two typical and important types for control about the pitch axis are 1) the pitch-rate control system

and 2) the normal acceleration-control system, as illustrated in Figs. 4 and 5 respectively. Each of these systems has qualities that particularly suit its type to specific kinds of weapon delivery. The purpose of a pitch-rate control system is to achieve within a sufficiently short time a pitch angular velocity of the aircraft proportional to an applied input command. Simultaneously, it must minimize angular deviations that are produced by atmospheric turbulence. The function of the normal acceleration-control system is to produce a normal acceleration of the aircraft in response to command inputs while minimizing changes in flight path caused by gust disturbances.

The pitch-rate control system of Fig. 4 is a two-loop system. The inner loop deflects the elevators an amount proportional to the negative of pitch rate providing whatever additional damping of pitching motions is required. The outer loop deflects the elevators an additional amount proportional to the time integral of the difference between the commanded pitch rate and the actual pitch rate so the system will not only respond correctly to pitch-rate commands, but, in the absence of commands, will also tend to maintain the pitch attitude fixed despite all other disturbing influences.

The acceleration-control system of Fig. 5 appears as a three-loop system. Again, the inner loop provides additional damping of the airframe. The next loop deflects the elevators an amount proportional to the normal acceleration, which feedback is sometimes quite useful in compensating for an adverse location of the airframe center of gravity relative to its center of pressure (i.e., for a non-optimium margin of static airframe stability). Again, the outer feedback loop attempts to insure that all acceleration commands are satisfied with the prescribed normal acceleration.

In both Figs. 4 and 5, the damping signals shown are supplied by rate gyros. However, it is rather important to note that by appropriate redesign of the signal modifier in Fig. 4 to include an approximate differentiating circuit, the rate gyro may be omitted entirely from the pitch rate-control system. Moreover, use of this same differentiator circuit in the signal

Fig. 3—Human operator tests with cockpit simulator.



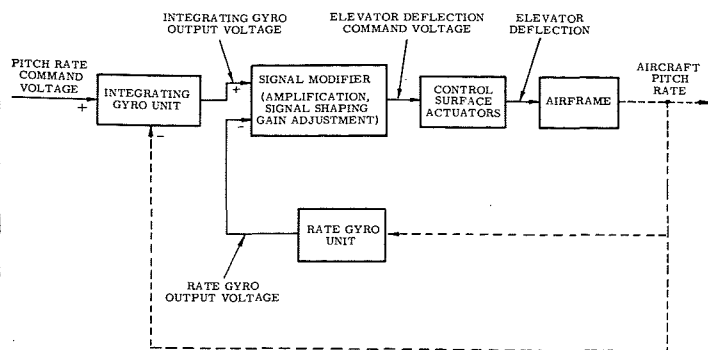

Fig. 4—Functional diagram of pitch rate control system.

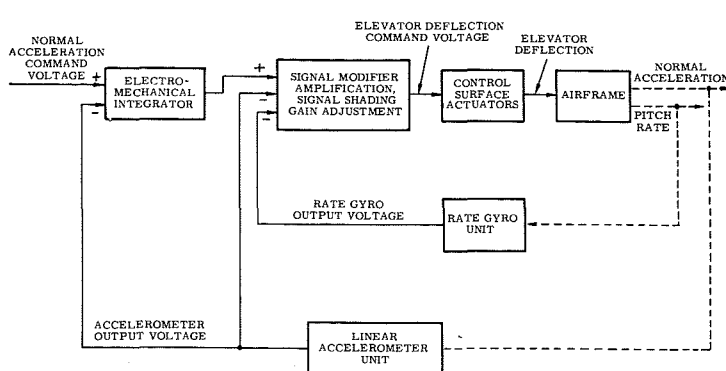

Fig. 5—Functional diagram of normal acceleration (flight path) control system.

modifier of Fig. 5 permits replacement of both the electromechanical integrator and the rate gyro by an integrating gyro in that system. Thus, both the pitch-rate control system and the acceleration-control system are capable of rather simple instrumentation with integrating gyros, if such instrumentation is preferred.

Fig. 6 compares analog-computed response data for the pitch-rate control system of Fig. 4 with that computed for the acceleration-control system of Fig. 5. The characteristics of a jet bomber flying at 20,000 feet of altitude were assumed in obtaining these results. The curves in Fig. 6 labeled "flight path turning rate" are proportional to normal acceleration when the effects of gravity have been properly compensated by subtracting a trigonometric term involving aircraft pitch and bank angles from the accelerometer output. The proportionality constant in this case is the reciprocal of aircraft forward velocity.

It can be seen in Fig. 6 that the pitch-rate control system controls pitch rate to the commanded value most rapidly, the flight path turning rate response being quite sluggish; whereas the acceleration control system controls flight path turning rate best, the pitch rate exhibiting a sizeable overshoot. Thus, pitch-rate control is superior for applications requiring precise airframe orientation control such as in aiming guns or for launching missiles that obtain their initial geometric reference from the launching aircraft's orientation. On the other hand, as shown in Fig. 6, the acceleration control system is advantageous for applications where proper aiming of the weapons is gov-

erned more by the aircraft flight path. Thus, acceleration control (or flight path control) has an advantage either for bombing or for unguided rockets which "weathercock" into the relative wind.

#### ADAPTIVE FLIGHT CONTROL SYSTEMS

Recently, as military aircraft have had to fly at higher speeds and at higher altitudes, not only have the basic aircraft dynamics continued to grow more severe, requiring more sophisticated control mechanisms, but also the total variation of these dynamic characteristics from one extreme to the other has widened, varying often over ranges exceeding 100:1. Provided sufficient information about the variation of airframe characteristics is available for all flight conditions, the synthesis procedure already described can be applied to calculate appropriate matching variations in the equalization parameters. In all operational craft today these adjustments, when necessary, are "scheduled" as appropriate functions of measured variations in such flight parameters as altitude, Mach number, dynamic pressure, etc.

The disadvantages of such open-loop adjustment of the equalization elements are several: First, the air data must be measured for all conditions. Second, the calculation of the necessary adjustments requires considerable amounts of time. Third, detailed and accurate information about aircraft characteristics is required over the entire flight regime; and fourth, the end result still is a system being adjusted in an open-loop fashion even though the adjustment may no longer be appropriate. Because

such a system must be refined by extensive flight tests, some aircraft are not being provided with complete flight-control systems by this method until two or more years after the first test flights.

For the reasons cited, programs have been established (by the U. S. Air Force,\* primarily) to investigate flight-control systems that automatically adjust their own parameters in a closed-loop manner without *a priori* knowledge of the aircraft parameters.

Fig. 7 shows functionally how the pitch-rate control system of Fig. 4 can be made self-adaptive. The two blocks in Fig. 7 in bold outline indicate the equipments which would replace those that would otherwise be needed to schedule the parameter adjustments on the basis of air-data measurements. The pitch-rate model in Fig. 7 has dynamic characteristics that make its output correspond to the ideal (desired) system response. The latter response is compared with the actual pitch rate response as measured with the rate gyro by a device here designated as "performance evaluator." In the latter, one or several appropriate performance criteria are applied to the actual system response. The performance evaluator then determines whether or not the equalization parameters are correct and, if not, in which direction they should be adjusted to achieve acceptable performance; it further commands such adjustment until acceptable performance is realized.

\*Raymond R. Rath, Capt., USAF, "Summary and Status of Adaptive Control System Program" WADC Technical Note 58-330; ASTIA Doc. No. AD205548 Wright Air Development Center, Sept. 1958.

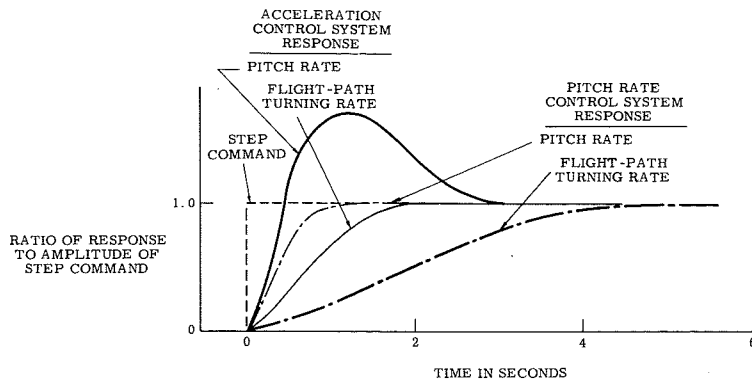

Fig. 6—Analog-computed step responses of normal acceleration control system and pitch rate control system for a typical bomber.

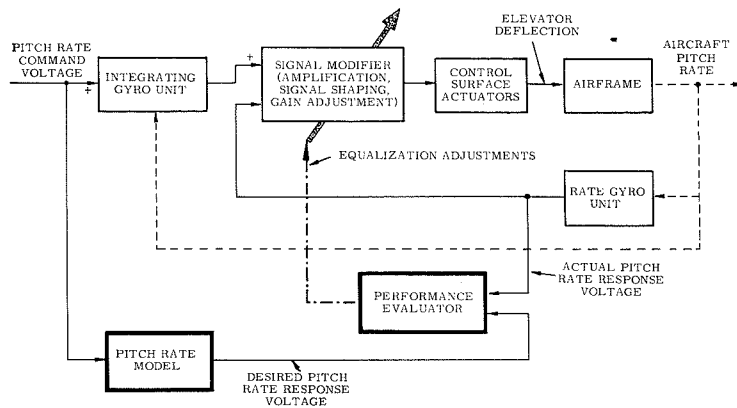
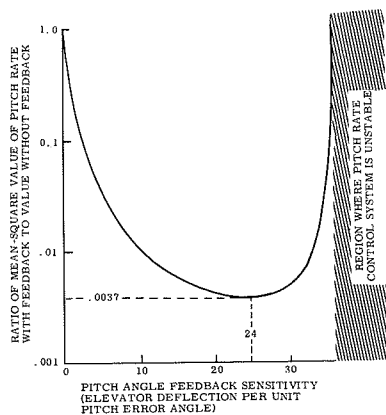

Fig. 7—Application of the self-adaptive principle to the pitch rate control system.

**SUMMARY**

Engineering design and development responsibility for a new weapon system should always include similar responsibility for the flight-control subsystem. The procedure for synthesis of flight-control systems today must consider adaptive as well as conven-

Fig. 8—Relative effect of random gust interference on pitch rate control system as a function of the outer-loop feedback sensitivity.



tional techniques because the self-adaptive capability is expected to become increasingly desirable if not actually mandatory. Moreover, adaptive techniques have already proved feasible in flight test. The design and development responsibility does not end, of course, with mere completion of the synthesis procedure, but rather continues until the final product is placed in operational use with the satisfied customer. Today RCA enjoys a unique position from which substantial gains in customer satisfaction can be achieved because of the recent, new concepts for packaging electronic parts into appreciably smaller and more reliable units, the micro-module for instance.

It is concluded that significant and satisfying improvements will appear in flight-control system performance, reliability, and maintainability once adaptive techniques have been properly incorporated and the advantages of the new packaging techniques fully exploited.



**DR. CARL W. STEEG, JR.** received his AB degree in mathematics from DePauw University and his Ph.D. from MIT in 1952. An MIT staff member since 1947, he joined RCA in 1957 as Manager of Analysis and Simulation at the DEP Waltham Laboratory (since moved to Burlington, Mass.), working in the simulation of weapon systems interceptor aircraft, target flight control systems, cockpit displays and problem geometry. He is a member of the American Mathematics Society, the American Association for Advancement of Science, and Sigma Xi. His latest book, *Control Systems Engineering*, was published in 1957 by McGraw-Hill.

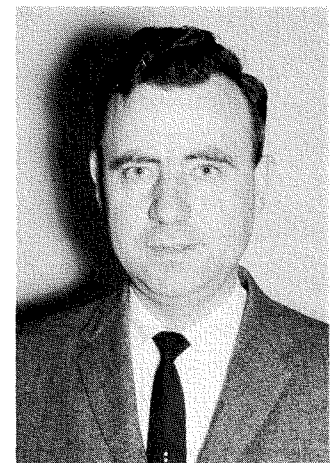

**FRANK A. BARNES** received his B.S. degree in Electrical Engineering from California Institute of Technology in 1944 and his M.S. and Professional degree in Electrical Engineering from M.I.T. in 1951.

At M.I.T. from 1946 to 1950, he was first employed as a teaching assistant in the Electrical Engineering Department and later as Research Associate in the Dynamic Analysis and Control Laboratory where he participated in the design, analysis, and simulation of guided missile systems. In 1950, he transferred to the Flight Control Laboratory and during the next five years served as Leader of the Missile System, Design, and Analysis group, and as Project Engineer for a hydrofoil craft guidance and control system.

Mr. Barnes joined RCA in 1955. His assignments have been managerial in the areas of interceptor system analysis, analysis and simulation, and project system engineering. His recent responsibilities include specialized analysis support to all departmental projects. He is Manager of the Navy "Final-Value" missile guidance project.

# A 17" PORTABLE TV RECEIVER WITH REMOTE CONTROL

by

ROBERT J. LEWIS, Mgr.

Television Receiver Circuit Design  
RCA Victor Television Division  
Cherry Hill, N. J.

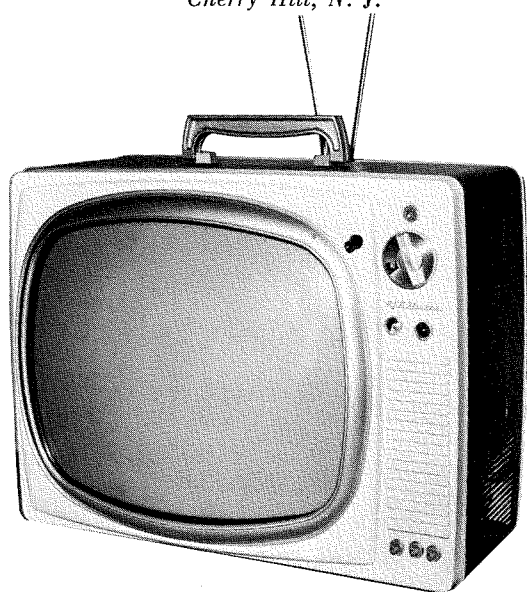

Fig. 1—Front view of the remote-control receiver with transmitter alongside. The pickup transducer opening can be seen over the station selector knob. The complete mechanical design was kept "slim," accommodating the remote control with a minimum increase of only 2 inches in depth.

**A** MINIMUM BACK-TO-FRONT dimension giving the "slim look" is the trend today in portable television receivers. Styling like this requires new design concepts in chassis layout, kinescopes, component parts, and in receiver operation. An important part of these modern trends is the rapidly increasing demand for remote control. And now RCA enters the low-price field with a new simplified two-function remote system

used in the receiver described here, which is one of the most recent models.

## VERSATILITY IN DESIGN

RCA's entire 1959-60 TV receiver line is aimed toward fulfilling the requirements of maximum serviceability and standardization. The number of basic chassis types is reduced to a minimum in order to decrease manufacturing change-over cost. The 17" TV portable

receiver with remote control described in this paper illustrates the effect of this program.

The new 17-inch line of television receivers consists of two portables, three table models, one portable with remote control, and one table model with remote control. When the decision was made to add the remote control model to the 17-inch line, it became necessary to increase the cabinet depth by 2 inches for this particular model to accommodate the remote receiver and switching motor. The "non-remote" models use a cabinet with a central wrap-around section  $4\frac{1}{2}$  inches deep and a maximum front-to-back dimension of  $11\frac{5}{8}$  inches.

The principal requirements which determined the physical aspects of the receiver design were as follows:

1. All customer controls must be on the front panel for ease of adjustment, and to permit adaptation of the basic model for built-in installations.

2. The back-to-front dimension of the basic chassis to be held to a minimum.

3. The speaker must be on the front panel.

4. A "cold" chassis with power transformer for maximum performance and safety. The power transformer requirement has had a large influence on the design because it involved chassis strength, flux coupling to the kinescope, heat considerations, and weight of the instrument.

Since picture tube length is the major factor in determining the depth of a TV receiver, it was apparent that a new kinescope was required. The  $110^\circ$  shortneck kinescope available then was not completely satisfactory from a performance standpoint. The Tube Division had been working on this problem and continued effort resulted in a new kinescope (17DKP4) with increased highlight brightness. This kinescope

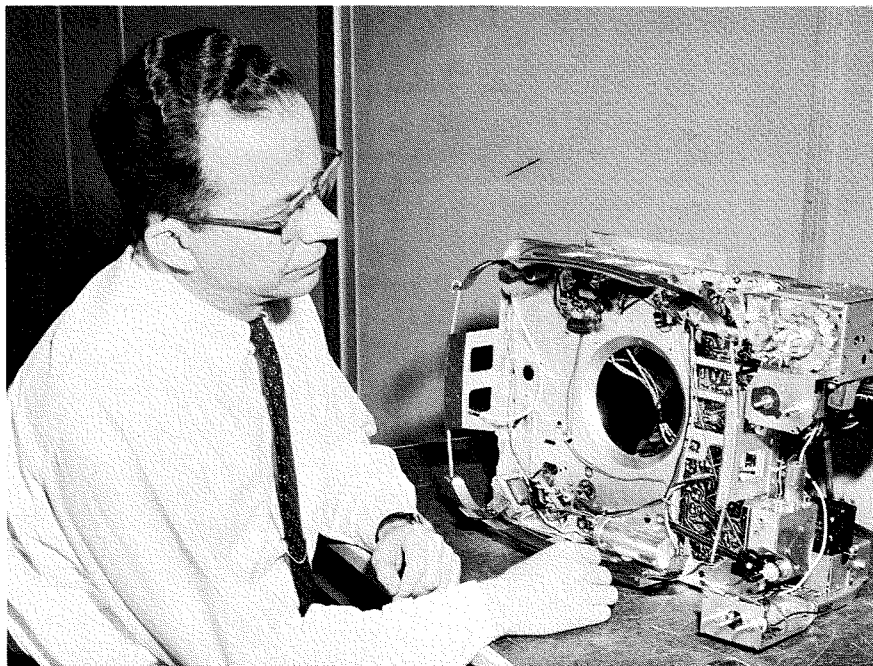

Fig. 2—The author examines the front side of the television receiver chassis. All connections on the printed-circuit boards can be reached through the large openings in the chassis. The programmer and pre-set mechanism are in upper right-hand corner.



has an overall length of only  $10\frac{11}{16}$  inches, with a neck length of  $3\frac{1}{16}$  inches.

#### DESCRIPTION OF TELEVISION RECEIVER CHASSIS

The tuner uses a tetrode r-f stage with a single-tuned circuit in the plate. A triode-pentode is used as the oscillator mixer. On the remote-control models, the tuner incorporates the preset type of fine tuning which permits independent fine tuning of each channel by the customer. After initial setup in the home, for the desired channels, it is only necessary to switch the channel selector in going from station to station without retouching the fine tuning. This feature permits simplification of the remote control systems by eliminating the fine-tuning requirement.

A small barrel-shaped programmer assembly measuring  $1\frac{1}{4}$  x  $1\frac{1}{2}$  inches slides over the front end of the tuner shaft in the remote models.

The customer can set the programmer to stop the tuner on the desired channels by sliding off the station selector knob and pushing the appropriate lever arms available through the hole in the cabinet. A 117-volt motor and gear assembly is added on the rear of the tuner on the remote-control models.

Approximately 70% of the chassis circuitry is on two printed-circuit boards. One board measuring  $4\frac{1}{2}$  x  $6\frac{1}{2}$  inches has 7 tubes and includes a three-stage stagger-tuned picture i-f amplifier, picture detector, sound i-f, locked-oscillator quadrature detector, sound output tube, video and first sync amplifier. A high-level contrast control is used to provide a constant signal level for the sync and AGC channel, thus eliminating "sync in sound" and picture "bending" with changes in contrast setting. These problems were formerly encountered when the contrast

Fig. 3—View with back cover removed. The remote-control receiver chassis is in the lower left corner. The switching motor and gear assembly mount on the rear of the tuner in the upper left corner. Practically all service work can be accomplished without removing the chassis from the wrap around.

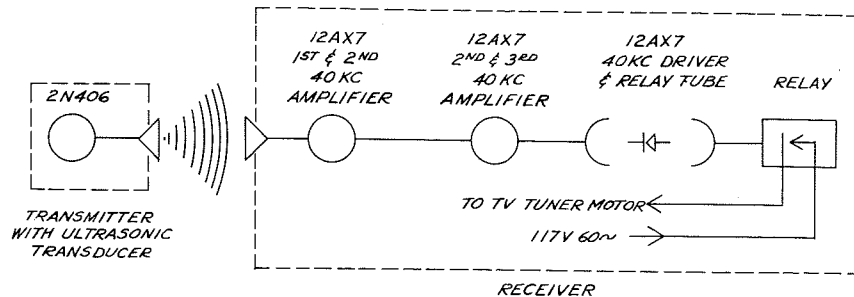
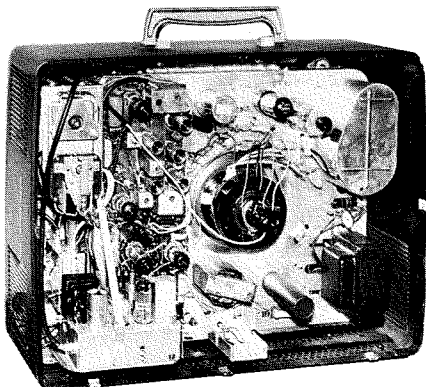

Fig. 4—Functional diagram of ultrasonic remote control system.

control was part of the cathode circuit of the video amplifier. The video amplifier provides 120 volts of signal drive to the kinescope.

The second printed-circuit board measures  $4\frac{1}{4}$  x  $5\frac{1}{2}$  inches, uses three dual tubes and provides for the second sync, AGC, horizontal oscillator and AFC, vertical oscillator and output functions.

A keyed type of amplified AGC system is used, providing good noise immunity and having the ability to handle wide variations in signal input level without readjustment of controls.

The horizontal output circuit and high-voltage box were designed to accommodate the new kinescope shapes and size limitations of the slim type construction.

#### NEW REMOTE CONTROL

The acoustic remote-control system in this model allows the customer to switch channels or turn the television receiver off and on from a remote position. If the tuner is in cycle and the transmitter button is not held down when the selector switch reaches the 14th position, the selector will stop

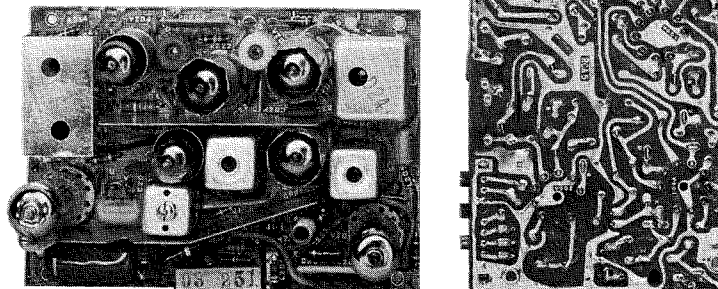

Fig. 5—View showing the two security sealed circuits used in the 17" portable. The one on the left shows the advances made in consolidation of many circuits on one relatively small panel. An ink outline of the wiring appears on the panel along with component numbers to aid servicing. The security sealed circuit on a similar panel at the right includes the sync and deflection components.

Solderless wire-wrap connections are used for connections to the boards. An outline of the copper pattern and R and C identification numbers are silk-screened on the component side of the boards to facilitate servicing. Most of the resistors on the board are inserted by automatic machines.

These two boards, plus one other four-tube board which provides a pentode vertical output for the receiver requiring more deflection power, are the three basic boards used in all of the 1959-60 television receivers. Minor changes in the components on the board or circuits added on the main chassis provide for the additional performance features required in certain models.

and power will be removed from television receiver chassis. If the transmitter button is pushed again, the tuner will switch to the next programmed channel and the power will again be applied to the television chassis. The master "off on" switch is on the television receiver. The CW type of transmitter allows the user to skip any programmed channel or the "stand-by off" position by merely holding the button down. This provides an advantage over the resonated bar and trip hammer system used in some competitive receivers.

The remote-control transmitter contains a 4-volt battery, one transistor with associate parts and a capacitor type transducer. The case measures approxi-

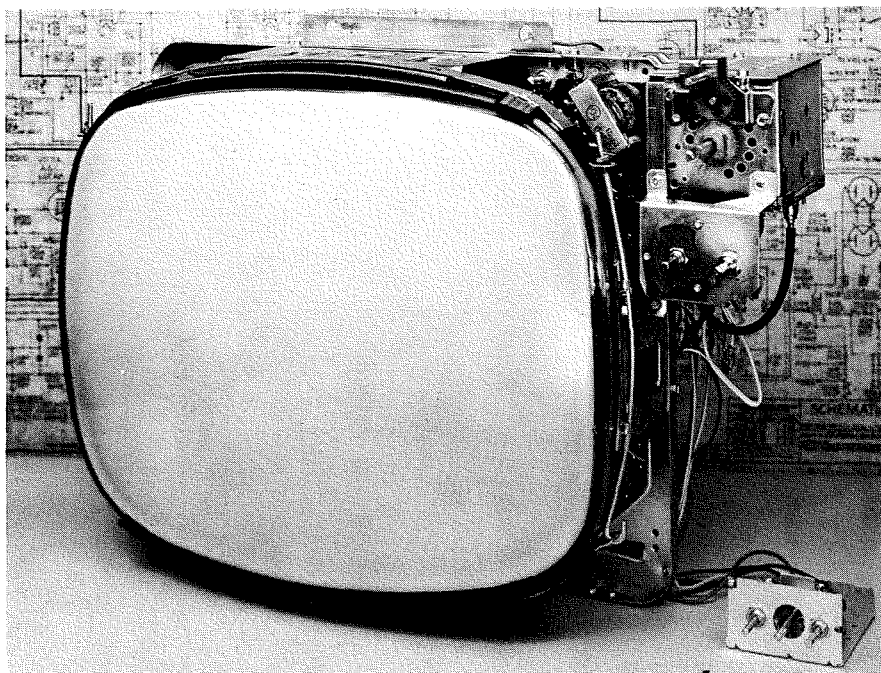

Fig. 6—This view shows the serviceability of the entire chassis with kinescope attached. This whole assembly as shown can be easily removed from the cabinet.

mately 1 x 2 x 3 inches. A 40-kc signal is radiated from the transmitter and picked up by a capacitance type microphone mounted directly over the station selector in the receiver. The remote-control receiver uses three tubes, a diode detector and silicon power rectifier. For standardization reasons the remote receiver has its own power supply.

The remote-control receiver has a sensitivity of approximately 6 microvolts, and will operate the TV receiver at distances up to 75 feet.

The remote transmitter and receiver used in this instrument were designed by Color Receiver Product Design at Cherry Hill. A later issue of the RCA ENGINEER will include an article by the engineers involved, describing this system in detail.

The overall project represents the combined efforts of several groups in the Black and White Television Receiver Product Design Section at Cherry Hill.

#### DESIGN PROBLEMS ENCOUNTERED

Efficient cooling of the chassis components becomes more of a problem with the slim type design. A heat pocket is

formed in the top of the cabinet and styling limitations on holes or louvres in the top area make this problem even more difficult. It was solved by chassis layout and investigation of many ventilation patterns.

Adding the remote-control receiver instrument contributed 20 watts to the heat problem. This heat increase was offset by changing the television receiver power supply from a 5AS4 full-wave tube type to a doubler using two silicon rectifiers. The tube rectifier is still used in the non-remote models for cost reasons.

Suppression of harmonics generated in the picture and sound detector circuits receives major consideration in any new television receiver chassis design. If the standard 40-mc picture i-f frequency and 4.5 mc sound channels are used, it is possible for harmonics generated in these circuits to couple back to the input by various paths and cause interference patterns with the desired signal on the kinescope. The second harmonic of the 41.25 mc sound i-f carrier generated in the picture detector can cause interference on channel 6. The fourth harmonic

**ROBERT J. LEWIS** received the Diploma in Electrical Engineering from the Drexel Institute of Technology Evening School in 1939. He joined RCA in 1941 as a Manufacturing Development Engineer in the Home Instrument Division and after Pearl Harbor assisted in the conversion from commercial to government work. He served as liaison engineer on several altimeter projects and the television glide bomb project (Block). He advanced to group supervisor in the manufacturing division laboratory. In 1944 he transferred to the Block Equipment design section and was a member of the group that designed the first post war TV receiver.

He designed the sound and picture i-f amplifiers used in RCA-TV receivers from 1946-1949 and spearheaded the engineering program converting the television division to printed circuits and automation. He advanced to his present position as Group Manager, Television Receiver Circuit Design. He is a senior member, IRE and has served on EIA and IRE committees.



of the 45.75 mc picture i-f carrier causes interference on channels 7 and 8.

Spurious radiation from the sound channel can cause interference on several of the high VHF channels as well as the low ones, plus the UHF channels. The slim type of styling makes these problems even more difficult because of the close proximity of the built-in antenna system, tuner and second detector circuits. Careful layout of the circuits on the printed board, insertion of filters in several circuits, and correct shielding of detector circuit provided the solution. In many cases, the harmonic problem cannot be solved until receivers are built on the assembly line and corrections made to compensate the normal production variations.

Production of the basic model of this series of receivers (170P04) started in March of this year and was well received by the Manufacturing Division. The simplified chassis and instrument construction allowed the production lines to attain maximum rate in a shorter than normal time. At this date several thousand of the receivers are in the field and acceptance has been very high.

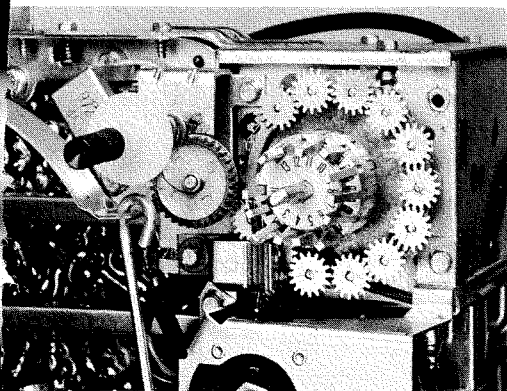

Fig. 7—This view shows the interesting mechanical design of the programming unit which permits remote selection of desired channels. The programming mechanism is easily accessible to the user when the channel selector knob is removed. The circle of gears shown constitutes the "one-set" fine-tuning assembly.

# A BREAKTHROUGH IN SCIENCE EDUCATION

*RCA Engineers active in secondary school science program*

by

**RUSSELL J. HALL**

*Assistant Editor  
RCA ENGINEER*

WITH LITTLE FANFARE, a group of RCA engineers and scientists in the Camden area, along with others from local industry, have been volunteering their effort toward one of the great problems facing the United States today: "Can we assure ourselves of a continuing supply of scientists and engineers to meet the growing demand?"

Seven-thirty every Wednesday evening at Haddonfield High School, near Camden, a group of twenty-five exceptional students meets with a team of scientists and engineers from local industry in a series of seminars. The seminars, administered by the school, are under the guidance of the Joe Berg Foundation, a philanthropic organization for advancing science in secondary schools.

## INCEPTION OF THE JOE BERG FOUNDATION

The Joe Berg Foundation has an interesting history. It all started with Jacob Shapiro, a former high-school science teacher from Tennessee who forsook his profession in order to earn support for his family by entering industry. But Shapiro could not get the "teaching bug" out of his system. He had found great satisfaction in his teaching career, particularly in tutoring exceptional students.

With the desire to teach running strong, he offered a plan to a Skokie, Illinois, high-school superintendent: he would set up free a special after-hours class for exceptional science students.

The welcomed plan was initiated with a "power exam" to screen students, and a final selection of 14 started the program. Shapiro soon found himself "snowed under" by questions in fields of science well beyond his experience, but with the aid of scientists from local industry, a pattern of seminars emerged.

With topics and curriculum mutually agreed upon by teachers and students, each scientist-teacher and a group of three or four interested students worked

up a lecture and demonstration, while the rest of the students read up on the subject. Each weekly seminar thus provided an overall acquaintance with a different area of science.

In a later phase of the program each student undertook a research project in his area of interest, and results of these projects have, in many cases, been astounding in their depth and competence.

One of Shapiro's students in a subsequent class was Joe Berg's grandson, young Stanley. Stanley's father, Arthur, a physicist, impressed with the program, recommended that Shapiro extend it to other schools. When the question of funds arose, Arthur Berg convinced his father, Chicago industrialist Joseph Berg, of the value of this program and a foundation was set up for the program's expansion. Since that time over 160 schools have subscribed to the program under Jacob Shapiro's direction.

## THE FOUNDATION'S ROLE

The Joe Berg Foundation offers no subsidies, scholarships or teaching grants. To any school or community requesting it, however, the foundation offers aid in setting up a seminar unit. With volunteer teaching assistance readily available from local industry, the plan provides invaluable and hitherto undreamed of opportunity for the exceptional science student at little tax cost to the community. In Skokie, for example, yearly costs amounted to \$6 per student per year.

The program provides no additional school credit for the students, who must maintain their regular school grades to stay in the program. Yet enthusiasm is extremely high for the seminars among the student body, with many schools setting up additional seminars of mathematics, and social sciences.

## NEED FOR THE PROGRAM

Mr. Shapiro, in summing the need for continuance and extension of the program, says, "It is commonly agreed among educators that a truly effective program for the relief of the shortage of scientific and technological workers must have the secondary school as a matrix. It is there that the future scientist and engineer must be identified at the ninth or tenth grade so that he will

not pass up the election of the essential preparatory studies in basic mathematics and science. It is there that his potential must be activated, nurtured and cultivated. The ultimate army of scientists and technologists must be recruited in the secondary schools.

"One of the most perplexing problems facing educators today is the utilization of the talents of the gifted child . . . The problems for the secondary school administrators in this area are immense. They are faced with critical shortages of teachers. In the field of science it has been extremely difficult for teachers to maintain proficiency in the light of rapid technological advances. Adequate research facilities for highly specialized science training are generally lacking, and funds to provide these facilities are, more often than not, also lacking."

In the two years of its operation, the Joe Berg Foundation and its program has an excellent chance of meeting these challenges and succeeding in its goals.

## THE SEMINARS AT HADDONFIELD

Haddonfield High School's participation in the program began in January, 1959, with the aid of Mr. Shapiro. Program Director is Dr. H. Nelson Crooks, RCA-DEP Development Engineering, Camden, and School Administrator is Roger W. Test, science teacher at the school.

"The seminars provide a broad insight into the transition from classroom to industry that is vital to the learning process for these selected science students," according to Perry H. Tyson, Principal of Haddonfield High School. "I am a firm believer in students having the opportunity to specialize in high school if their aptitudes so dictate," Mr. Tyson continued, "And evidence from the program thus far indicates that many seeds are being planted in fertile minds through the efforts of this fine group of scientist-teachers that would otherwise be far out of reach. The program is bound to bear fruit."

The prospectus of seminars not only includes subjects from RCA technology, but others such as Microbiology, Food Technology, Biochemistry, Physiological Psychology, Petroleum Chemistry, Meteorology, and Cytology, taught by scientists from local industries.

This impressive list of subjects is certainly challenging to a high-school student, even to the exceptional ones.

The scientists and engineers teaching the seminars find themselves challenged,

For Mr. Hall's Biographical Sketch, see Vol. 2, No. 1, P. 35.

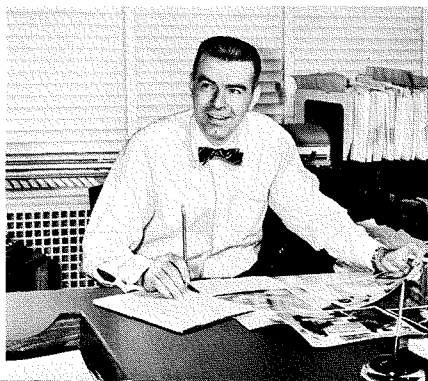

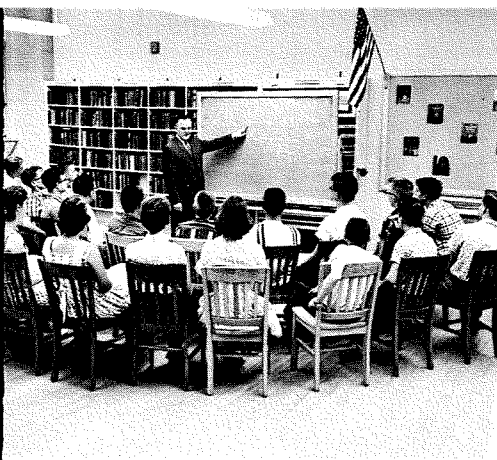

Classroom scene with Murlan Corrington instructing Science Students at Haddonfield High.

also, by the precocious inquiries of the students. D. Rogers Crosby of IEP Communications Engineering has this to say:

Teaching the Haddonfield High School science group furnishes an instructive contrast to my other teaching experience this year in a mathematics course at RCA and in an engineering course at Rutgers University. The high school students tend to use logic in their solutions more than do the engineers. The approach of an engineer is to search for an analogue in his own experience to a problem. This approach frequently gives realistic answers; however, the habitual practice of such a practical attitude may result in some atrophy and loss of confidence in one's ability to reason in unfamiliar fields.

In contrast, the young mind with a negligible amount of experience is forced to exploit more completely the information inherent in the statement of the problem. Thus class discussions with them frequently are of sylogistic nature, and are stimulating and challenging in their freshness of approach.

We can hope for the continuing of this program for the benefit it is sure to provide in expanding our technology. We can also hope that many more schools will become active under the direction of the Joe Berg Foundation. We know that industry's scientists and engineers will help in this grand enterprise.

The "Joe Berg" Seminars can be considered as a catalyst in precipitating other programs of similar nature. For example, the author is aware of secondary school programs involving RCA engineers at Delaware Township (N. J.) High School (Sidney Kaplan, RCA-AEP), Moorestown (N. J.) High School (T. G. Green, RCA-DEP), and the Lancaster (Pa.) School District (W. N. Parker, D. L. Roberts, et al.). Undoubtedly there are other programs, with other RCA Engineers devoting time and effort as unselfishly as those mentioned here.

### THE SCIENTIST AND THE HIGH SCHOOL STUDENT

I haven't yet found an engineer or scientist who doesn't like to talk about his work. Our science seminar program offers each of our staff members excellent opportunity to "sound off," and a more receptive audience could hardly be found. We attempt not only to teach scientific fact and method, but just as importantly, to demonstrate to the students our attitude toward science, our interest in our work, and our objective approach. Our program gives the students a chance to associate with adults outside their families on an informal and yet respectful and worthwhile basis. It is also worth noting that the engineers participating in the program seem to get as much from the lectures of other staff members as do the students, and I sometimes wonder who is benefiting most. In summary, I highly recommend the program to other engineers and scientists and assure them that they will find participation in a high school science seminar program a highly rewarding experience.

Dr. H. N. Crooks  
Development Engineering  
Defense Electronic Products  
Camden, N. J.

### MOTIVATION IN MATHEMATICS

It should never be necessary to tell any student that a course of mathematical study is a necessary evil. The problems should be a combination of theory and practice, so chosen that it will be obvious that they are from everyday life. All problems should be presented in practical terms, as mechanical drawings, dimensioned and labeled according to engineering standards, where possible. Emphasis should be placed on obtaining solutions by clear thinking, and not by blind substitution in formulas.

Many of the old-fashioned puzzle problems that are traditional in algebra should be eliminated. Development of proficiency in algebra should be a means to an end, not an end in itself. Geometry should use modern algebraic symbols and proofs, rather than the cumbersome methods of Euclid.

Considerable emphasis should be placed on numerical computation and methods of checking because most engineering problems require reliable numerical answers. There is often a wide gap between the theory and the actual calculation that can only be closed by the detailed understanding obtained by plotting a graph of the result.

Murlan S. Corrington  
Development Engineering  
Defense Electronic Products  
Camden, N. J.

### A LINK BETWEEN INDUSTRY AND THE STUDENT

Apart from Sputniks, cold wars, and the like, there has long been a need for the workaday world to play a larger part in the education of young people. In the days when family and community life and the processes of economic production were almost indistinguishable, young people were largely educated by taking part in the economic process from an early age. In recent times, as Peter Drucker has put it, the family (and community) has been "exploded by industrialism." Except for the consumptive phase of economic life, economic activities are largely hidden far away behind the walls of factories and large commercial enterprises, where young people can learn little of them or from them until they attain adulthood. A great educative resource that was once a paramount is denied them.

Obviously one cannot argue that young people should now be put behind factory walls to gain education. But it may be hoped that the new science seminars, and possibly other similar activities, will gradually grow into a link between the world of production and young students, and that this link will in some degree further their education by breaking down their isolation from the basic activities by which men live.

L. T. Sachtleben  
Development Engineering  
Defense Electronic Products  
Camden, N. J.

Dr. H. N. Crooks  
(Program Director)  
... Electrical  
Engineering—Circuits

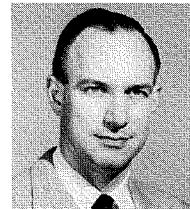

D. R. Crosby  
... Mathematics,  
Electromagnetic  
Propogation

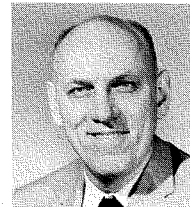

Dr. J. H. Reisner  
... Physics and  
Electron Optics



M. S. Corrington  
... Mathematics  
and Physics

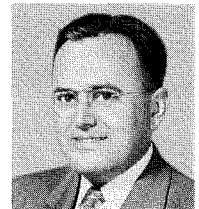

D. J. Parker  
... Optics,  
Superconductivity

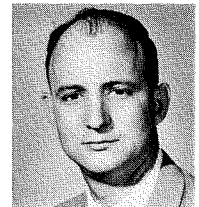

L. T. Sachtleben  
... Optics,  
Photographic  
Processes

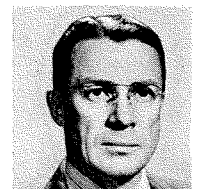

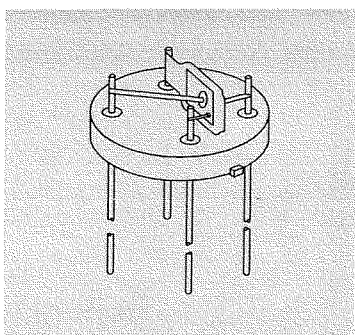

Fig. 1 — Cutaway drawing of developmental diode-triode transistor.

## NEW DIODE-TRIODE TRANSISTOR FOR DETECTOR-DRIVER SERVICE

by

DEREK THORNE and ROGER V. FOURNIER

Semiconductor and Materials Division  
Somerville, New Jersey

THIS PAPER DESCRIBES the use of a new semiconductor device, a diode-triode transistor, to improve detection, automatic gain control, and audio amplification in transistorized broadcast-band receivers. It increases the detector efficiency of battery-operated broadcast-band receivers.

The new multi-unit transistor consists of an alloyed p-n junction (diode unit) for use as a detector and an alloyed p-n-p junction (triode unit) for use as an audio amplifier. The two units are constructed on one germanium pellet so that the n-type base region is common to both units. This construction provides direct connection between the diode and triode units and permits the use of fewer circuit components. A cutaway drawing is shown in Fig. 1.

### DESIGN DETAILS

The triode unit of this developmental transistor is designed for use as a low-power class A audio-frequency amplifier. For this application, certain characteristics must be closely controlled to provide the desired operating performance. For uniform amplification over the audio-frequency range the triode unit is designed to have a frequency cutoff in a common-base circuit of 1 megacycle. This cutoff value is obtained with a junction spacing of 1.6 mils. A resistivity range of 2 to 4 ohm-centimeters is used to provide low saturation current and high breakdown voltage. This resistivity range produces  $r_{bb}$  values of 100 ohms or less.

The use of a gallium-silver-indium alloy as the emitter-dot material results in high hole-injection efficiency. For the spacing used, therefore, values of beta (d-c current gain in a common-emitter, base-input circuit) of 70 are

easily obtained. This material also produces a flat "fall-off" characteristic which assures uniform current gain over the desired range of collector current.

The high average beta of the triode unit results in a moderately high input impedance, approximately 2000 ohms, in the common-emitter, base-input circuit. This impedance represents better diode loading than that of most detector circuits at sensitivity level, advantageous from the view of detector efficiency and distortion.

When used as a detector, the alloyed-junction diode unit has many advantages as compared to a point-contact diode. In particular, its forward characteristic is better because the higher injection efficiency obtained with an alloyed junction results in low forward resistance. The reverse characteristic is also markedly improved. Together these two factors result in considerably higher detection efficiency for the alloyed-junction diode unit. The static characteristics of the diode unit are compared with those of a typical point-contact detector diode in Fig. 2.

A prime requirement of this developmental transistor was that there should be no interaction between the diode and triode units. The mechanical construction of the device plays

an important part in preventing such interaction. The diode is alloyed on to the collector side of the base pellet after the collector has been alloyed. In this position, the diode is separated from the emitter by a distance greater than one diffusion length and from the collector by approximately one diffusion length. This separation effectively prevents interaction between the two units of the transistor. Because the alloying of an additional dot on the base material of an audio-driver transistor adds little to total cost, the diode-triode transistor can be priced to compete with a separate detector diode and audio driver.

### CIRCUIT CONSIDERATIONS

The use of the diode-triode transistor provides several advantages in transistorized broadcast-band receivers, chief of which are increased receiver sensitivity, better diode loading, amplified AGC, and low cost.

The increased receiver sensitivity is a result of the superior detection efficiency and gain characteristic of the diode-triode transistor as compared to those of conventional point-contact diode detectors and audio-driver circuits. Fig. 3 shows net gain measurements for two developmental multi-unit transistors and two conventional point-contact diodes. The gain was measured in the circuit shown in Fig. 3 with resistive loads serving as actual diode circuit loading.

The comparatively high input impedance of the triode unit of the developmental transistor and the absence of AGC a-c shunting provide a better a-c/d-c load ratio for the detector than that obtained in conventional detector circuits. This improved load ratio reduces the harmonic distortion.

The direct connection between the diode unit and the base of the triode unit makes it possible to design circuits which provide an amplified AGC voltage and thus contribute to a high AGC figure of merit for the

Fig. 2—Static characteristics of diode unit of developmental transistor and of typical point-contact detector diode.

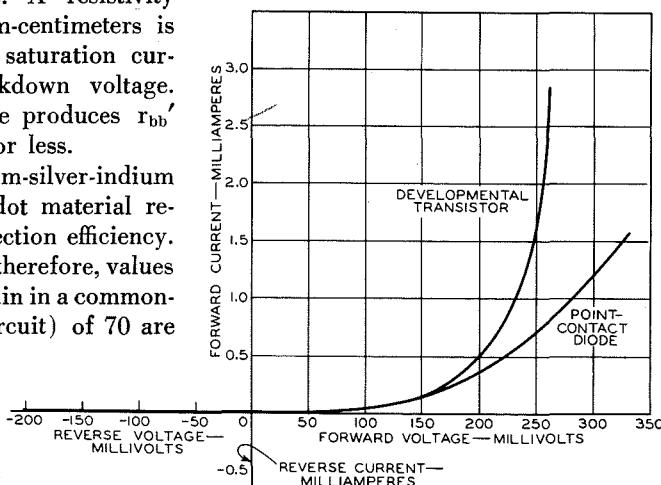



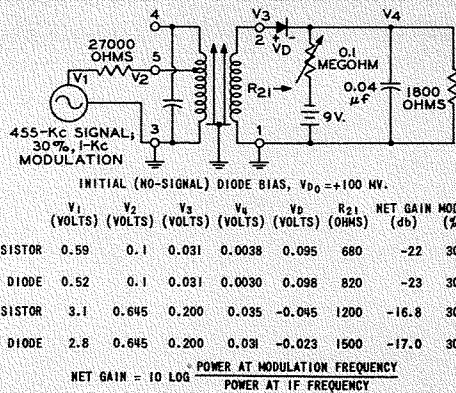

Fig. 3—Gain measurements for developmental multi-unit transistors and for typical point-contact diodes.

receiver. The point at which the amplified gain control voltage is derived is shown in Fig. 4(a). The operation of the diode-triode transistor in a typical receiver is discussed later.

A possible limitation of the device can be explained by the following description. When the amplitude of the modulated i-f signal is increased, the detector diode starts conducting and a positive-going voltage appears at the base of the triode unit. The unidirectional diode current is amplified by the current gain of the triode, and produces an amplified gain control voltage at the emitter. However, a positive-going voltage at the base of the triode unit is accompanied by a decrease in collector current. For strong input signals, if no AGC were applied to previous stages, the positive voltage at the base could shift the operation of the triode unit to a nonlinear region of its transconductance curve and cause distortion. In the design of the AGC network, therefore, the change of bias of the Class A-operated triode unit with received signal must be considered. A proper design criterion is the provision of sufficient AGC action to maintain the operating point of the triode unit in its most linear region.

It is usually not possible to design circuits which optimize every possible requirement. The design of the detector and AGC circuits must be integrated with the over-all receiver circuit design to provide adequate receiver performance. The receiver designs discussed in this paper represent a judicious balance of receiver AGC figure of merit, detector efficiency, and harmonic distortion to produce an economical receiver.

#### DETECTOR-DRIVER OUTPUT STAGES

Fig. 5 shows a simplified diagram of a six-transistor superheterodyne re-

ceiver using the developmental diode-triode transistor as the detector-driver. This receiver, which operates from a nine-volt supply, uses the RCA-2N412 in the first stage as an autodyne converter. In the next two stages, the RCA-2N410 is used as a grounded-emitter i-f amplifier with fixed neutralization on each stage. The fourth stage is the diode-triode transistor, serving as the detector and audio driver for the fifth stage, a push-pull Class B power amplifier.

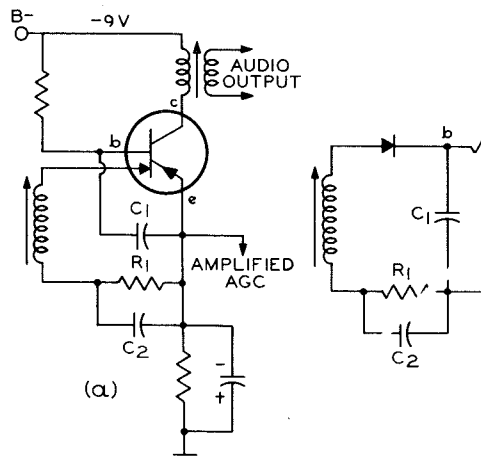

Fig. 4—AGC circuit using developmental diode-triode transistor.

The quiescent operating point of the detector-driver stage is designed to have a no-signal collector current of approximately 2 milliamperes by the proper choice of resistors  $R_1$ ,  $R_2$ ,  $R_3$ . This combination of bias resistors produces a forward bias of approximately 100 millivolts on the detector diode to reduce low-level distortion and improve detection efficiency. The audio load consists of a driver transformer having a primary impedance of 10,000 ohms in the collector circuit. Either a shunt-type volume control across the transformer primary or a feedback-type volume control from collector to base of the triode unit may be employed. Although the

latter type is preferred, it requires the use of an extra electrolytic capacitor for d-c isolation so bias will not change with volume-control changes.

As the amplitude of the input signal increases, the emitter current of the triode unit is influenced by the signal detection in the base circuit. As a result, the d-c voltage across  $R_1$  also changes. This voltage is used to control the emitter-to-base bias of the first i-f stage which, in turn, controls the power gain of the stage. Usually, the amplified AGC voltage derived from the circuit shown in Fig. 5 is sufficient to drive the i-f stage to cutoff. For input signals greater than 0.1 volt per meter, however, there is sufficient conduction through the i-f transistor to warrant the use of auxiliary means of gain control to avoid overloading of the i-f and driver circuits. This auxiliary control may be provided by the use of fractional AGC on the converter stage or by an auxiliary diode (see Fig. 5). This latter method is preferred because it avoids oscillator stability problems at reduced voltages.

#### DIODE-TRIODE AS FIRST AUDIO DRIVER

It is often desirable to design receivers with a large complement of gain stages to provide ease and flexibility in obtaining good sensitivity, signal-to-noise ratio, AGC, and desired power output. The increased number of stages provides greater uniformity of gain by allowing a greater degree of mismatch between stages, and thus also allows for greater interchangeability of units.

Maximum benefit can be obtained from the developmental multi-unit transistor when it is used in conjunction with a separate audio driver stage and a tuned r-f stage. The use of a tuned r-f stage provides great flexibility in the design of AGC networks and noticeably improves signal-to-noise performance. Fig. 6 shows a simplified diagram of a receiver

Fig. 5—Simplified diagram of six-transistor superheterodyne receiver.

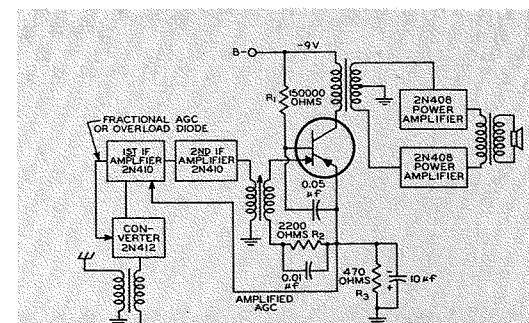

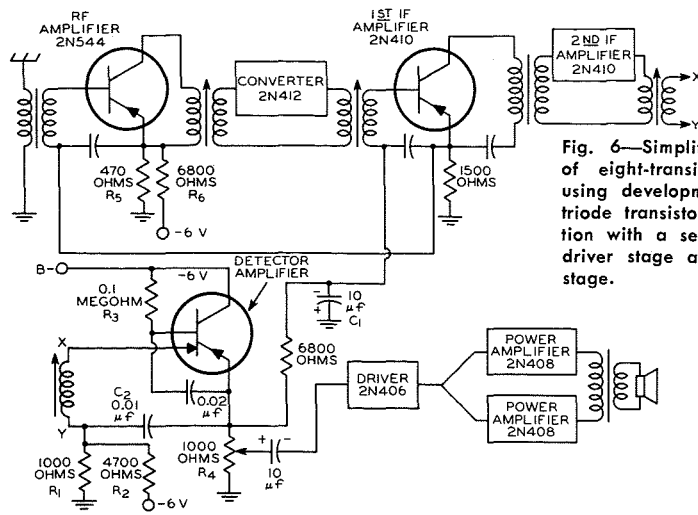

Fig. 6—Simplified diagram of eight-transistor receiver using developmental diode-triode transistor in conjunction with a separate audio driver stage and tuned r-f stage.

which operates from a six-volt supply and has a tuned r-f stage in addition to the converter and i-f stages to provide ample post-detection gain.

The detector stage in the circuit shown in Fig. 6 is an emitter-loaded common-emitter amplifier. The resistive element in the emitter, which provides the positive-going source of amplified AGC, also serves as a volume control for the receiver. The diode plate is clamped at approximately  $-1$  volt by the resistive voltage divider consisting of resistors  $R_1$  and  $R_2$ . The cathode potential of the diode unit is adjusted by means of resistor  $R_3$  to approximately  $-1.1$  volt to provide an initial no-signal forward bias of approximately 100 millivolts on the detector diode. The quiescent or no-signal current in the triode unit, which is established by resistors  $R_1$  through  $R_4$ , is approximately 1 milliamper. The low side of the i-f transformer secondary is returned to the triode emitter by means of capacitor  $C_1$ . Capacitor  $C_2$

serves as the detector if bypass. The d-c voltage drop across the emitter resistor  $R_4$  establishes the no-signal emitter current of the first i-f stage which, in turn, controls the operating point of the r-f stage. The initial value of emitter current in both the r-f and first i-f stages is approximately 0.5 ma.

As the amplitude of the i-f carrier increases, the unidirectional current flowing through the diode unit produces a positive-going potential,  $e_1$ , at the diode cathode. Because of the direct connection between the diode cathode and the base of the triode unit, the diode current is amplified by the current gain of the triode unit to produce an amplified form of gain control voltage  $e_2$  at the triode emitter. The positive-going voltage  $e_2$  reduces the emitter-to-base voltage of the first i-f transistor and causes a reduction in emitter current which, in turn, substantially reduces the i-f gain for the stage. In addition, the changing voltage  $e_2$  is further amplified by the common-emitter gain of

the i-f stage. This amplification produces a control voltage at the i-f-stage emitter which can be used to control the gain of the r-f stage. It should be noted that AGC action for both stages is achieved without shunting or loading of the detector. The detector load comprises the triode input impedance shunted by the bias resistor  $R_3$ . This resistor, which has a value of 100,000 ohms, produces negligible loading. The absence of AGC network loading, coupled with the moderately high input impedance of the triode, provides circuit advantages from the standpoint of detector distortion of the receiver at low signal levels.

One design objective for the receiver shown in Fig. 6 was that the AGC network should exercise control over the receiver gain for an extremely wide range of input signals without producing r-f overload in the front end or exceeding the dynamic range of the first audio driver. This objective requires that the AGC network prevent large i-f excursions from appearing at the detector. In addition, the detector-driver stage should be sufficiently stable to prevent non-linear operation, yet should allow enough change in emitter current with signal amplitude to provide good AGC performance. In practice, this optimum point may be difficult to achieve. At the expense of a slight amount of additional bleeder current in the r-f stage, however, it is possible to achieve exceedingly good AGC figure of merit. The bleeder network shown in Fig. 6, which consists of the emitter resistor  $R_5$  and resistor  $R_6$ , is adjusted until the emitter potential is slightly negative with respect to the base potential under conditions of strong input signals so that the r-f stage is effectively cut off and greatly attenuates incoming signals.

It is desirable to let the r-f stage handle most of the gain control for several reasons. First, there are no dynamic range problems encountered in this stage. Second, the small collector-to-base feedback capacitance of the RCA-2N544 drift transistor and the absence of neutralizing capacitance allow negligible feedthrough of incoming signals. Third, the excellent gain control of the r-f stage results in less severe requirements on the operating points of both the

Fig. 7—Schematic diagram for six-transistor receiver shown in Fig. 5.

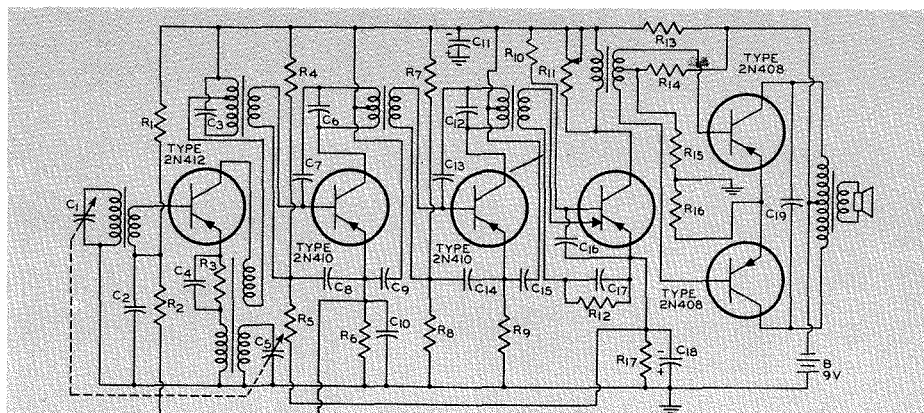

- |   |                                    |   |
|---|------------------------------------|---|
| $C_1 = 12 - 230 \mu\mu\text{f}$                       | $C_{15} C_{19} = 0.02 \mu\text{f}$ | $R_8 = 10000 \text{ ohms}$                            |
| $C_2 C_{17} = 0.01 \mu\text{f}$                       | $R_1 = 33000 \text{ ohms}$         | $R_9 = 1200 \text{ ohms}$                             |
| $C_3 C_6 C_{12} = 220 \mu\mu\text{f}$                 | $R_2 = 560 \text{ ohms}$           | $R_{10} = 150000 \text{ ohms}$                        |
| $C_4 C_8 C_9 C_{10} C_{14} C_{16} = 0.05 \mu\text{f}$ | $R_3 R_{12} = 2200 \text{ ohms}$   | $R_{11} = \text{potentiometer, } 100000 \text{ ohms}$ |
| $C_5 = 10 - 105 \mu\mu\text{f}$                       | $R_4 = 120000 \text{ ohms}$        | $R_{13} R_{15} = 100 \text{ ohms}$                    |
| $C_7 = 4 \mu\mu\text{f}$                              | $R_5 = 680 \text{ ohms}$           | $R_{14} = 6800 \text{ ohms}$                          |
| $C_{11} C_{18} = 50 \mu\text{f, electrolytic}$        | $R_6 = 1500 \text{ ohms}$          | $R_{16} = 10 \text{ ohms}$                            |
| $C_{13} = 6 \mu\mu\text{f}$                           | $R_7 = 62000 \text{ ohms}$         | $R_{17} = 470 \text{ ohms}$                           |

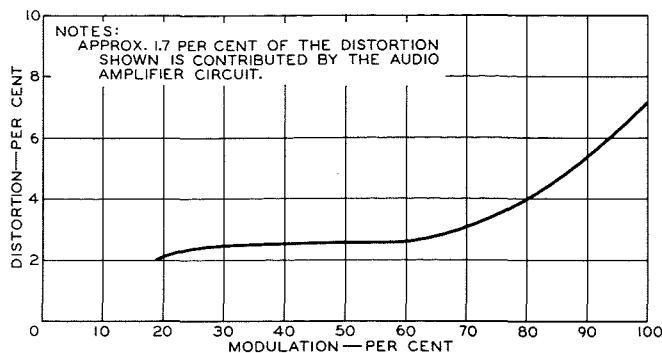
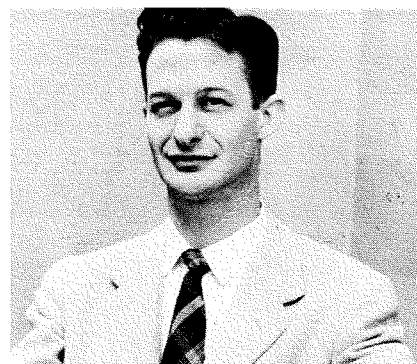

Fig. 8—Harmonic distortion of six-transistor receiver shown in Fig. 7 as a function of percent modulation for a fixed carrier level of 50 millivolts at the detector diode.



**DEREK THORNE** received his Bachelor of Science degree in Electrical Engineering from Kings College, Durham University, England in 1953. Mr. Thorne joined Standard Telephones and Cables, England, and did transistor design work in conjunction with circuits for audio amplifiers and hearing aids for the National Health Service.

In 1955, Mr. Thorne joined RCA in Montreal, Canada, as a transistor design engineer. He later transferred to the RCA Semiconductor and Materials Division, Somerville, N. J.

detector-driver and first i-f stages. For example, in the circuit shown in Fig. 6, an input signal of 0.1 volt per meter (representing a strong local signal) produces an emitter-current change of only 300 microamperes in the driver stage, 200 microamperes in the first i-f stage, and 0.5 milliampere in the r-f stage (which is close to cutoff). The AGC figure of merit for this performance is 48 db.

#### OVER-ALL RECEIVER CHARACTERISTICS

The schematic diagram for the six-transistor superheterodyne receiver using the developmental diode-triode transistor as a detector-driver is shown in Fig. 7. This receiver has a typical sensitivity of 200 microvolts per meter for a power output of 50 milliwatts. An AGC figure of merit of 52 db is obtained when an input signal of 0.1 volt per meter is used as a reference.

**ROGER V. FOURNIER** received the B.S. degree in Electrical Engineering from the University of Maine in 1950 and the M.S. degree in Electrical Engineering from the University of Connecticut in 1956. He served with the U. S. Navy from 1943 to 1946, during which time he attended naval electrical school and the Sperry Gyro-Compass school, and then served on board a destroyer escort, where he was responsible for maintaining proper operation of the ship's interior communications equipment, master gyro-compass and gyro-repeaters in fire-control, radar, and sonar equipments. From 1950 to 1956, he was employed at the U.S.N. Underwater Sound Laboratory in New London, Conn., as an electronics scientist developing new and improved electronic circuits for use in sonar equipment, as well as instrumentation systems for basic sonar research. During that time he also designed and developed the first transistorized pre-amplifiers for use in conjunction with sonar system hydrophones. He joined the RCA Semiconductor Division in November, 1956, as an engineer in the Advanced Circuit Development activity of the Applications Laboratory.

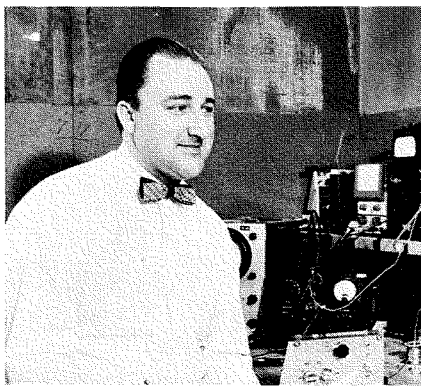

Fig. 8 shows the total harmonic distortion of the receiver as a function of percent modulation for a fixed carrier level of 50 millivolts at the detector diode. The values of distortion shown include approximately 1.7 per cent distortion contributed by the audio circuits. Undoubtedly, the audio circuits also cancel some of the diode distortion, especially at high modulation percentages where more than 7 per cent total harmonic distortion would normally be expected.

The six-transistor receiver of Fig. 6 may be expanded to an eight-transistor superheterodyne by using the 2N544 drift transistor in a tuned r-f stage and the 2N406 alloy-junction transistor as a separate audio driver. The remaining transistor complement is the same as that shown in Fig. 6. This receiver has a sensitivity of 85 microvolts per meter for a power output of 50 milliwatts. A typical signal-to-noise ratio of 18 db is obtained for an input signal strength of 100 microvolts per meter at a frequency of 1 megacycle. This signal-to-noise ratio is exceptionally good for a small battery-operated portable set. Curves of total harmonic distortion as a fraction of per-cent

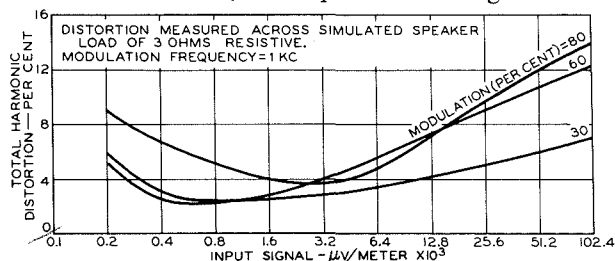

Fig. 9—Distortion of eight-transistor receiver as a function of input-signal level for several values of per-cent modulation.

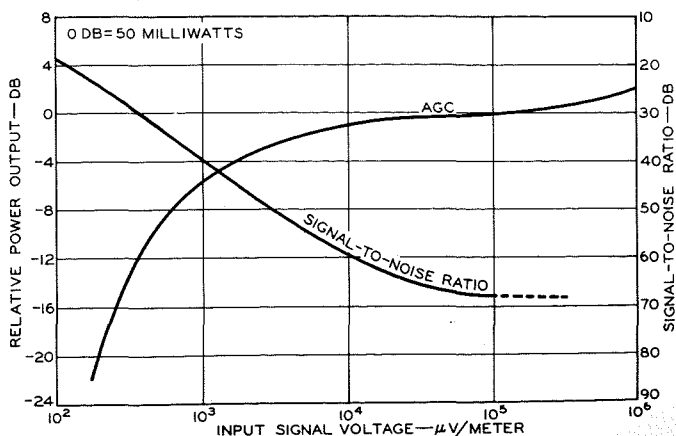

Fig. 10—Power output and signal-to-noise ratio of typical eight-transistor receiver as functions of input-signal level.

modulation for various input-signal levels are shown in Fig. 9. These curves include approximately 3 per cent of the distortion contributed by the audio amplifier stages.

Fig. 10 shows the power output and signal-to-noise ratio of the eight-transistor receiver as functions of input-signal level. The reference frequency was 1 megacycle, 30-per-cent, 1-kilocycle modulated. The volume control was adjusted for a 50-milliwatt power output for an input signal of 0.1 volt per meter. The AGC figure of merit for this signal level is 48 db. The figure of merit is 56 db for a signal of 0.256 volt per meter and 62 db for a signal of 0.8 volt per meter.

#### ACKNOWLEDGMENT

The authors wish to acknowledge the valuable assistance of Messrs. R. M. Cohen, H. V. Kettering, and J. W. Englund.

# INTEGRATED SEMICONDUCTOR DEVICES\*

**J. T. WALLMARK**

*RCA Laboratories  
Princeton, N. J.*

**S. M. MARCUS**

*Defense Electronic Products  
Camden, N. J.*

**D**URING THE LAST FEW years a great deal of interest has been focused on the utilization of solid-state phenomena for various circuit functions in electronic equipment. It has been pointed out, e.g. by E. W. Herold<sup>1</sup> that, in addition to the conventional circuit functions, such utilization may lead to new and unusual effects that cannot easily be achieved with conventional components.

This article describes an example of this philosophy, namely, *integrated semiconductor devices*. An integrated semiconductor device is one in which active as well as passive component functions have been integrated into a single piece of semiconductor with no interconnecting metallic leads. While the integrated device concept is quite general and applicable to any kind (class) of devices such as electron tubes or relays, it is in semiconductors that its advantages are perhaps most obvious.

The main advantage of integrated devices, to be described in this article, is their extremely compact form, which may allow true microminiature electronic equipment to be built with a packing density of approximately  $10^8$  parts per cubic foot.

## INTEGRATED SHIFT REGISTER

In order to illustrate the principle of integrated devices, let us consider a *shift register*, one stage of which is shown in Fig. 1a. The stage consists of a thyristor<sup>2</sup>, a device which exhibits a negative resistance characteristic within a certain range of current and voltage, and, therefore, may be used as a bistable element to store one digit, "zero" or "one." This digit may be shifted to the adjacent stage by applying a shift pulse which in effect turns all the stages OFF. From a stage that was ON, a pulse is sent to the adjacent stage turning it ON via the interconnecting RC-circuit. This RC-circuit should have a time constant that is long enough to store the infor-

mation while the stages themselves are cleared and thus made ready to receive new information. In this sense it constitutes a temporary storage.

In Fig. 1b the RC-circuit has been replaced by a semiconductor delay line consisting of a small bar of germanium. The shift pulse is applied along this bar and sends minority carriers from the ON stage down the bar. The minority carriers are collected at the end of the bar after a time interval equal to the transit time, and used to trigger on the next stage. The complete shift register may take the form shown in Fig. 2 which shows two versions, one where the elements are arranged in series, and one where the elements are arranged in parallel. It has been found that the parallel arrangement, although slightly more complicated as far as connecting leads go, offers advantages in that it reduces the problem of shrinkage in thyristor fabrication.

## INTEGRATED DEVICES USING DIRECT-COUPLED UNIPOLAR TRANSISTOR LOGIC<sup>3</sup>

A second integrated device, or rather a whole group of integrated circuits, utilizes the *unipolar transistor*.<sup>4</sup> The name given this class of integrated circuits is DCUTL. This unipolar transistor, one version of which is shown in Fig. 3, operates in the following manner. When a reverse bias is applied to the gate contact, the depletion layer of the p-n junction grows and encroaches upon the channel region, making it narrower, until the resistance from source to drain becomes very high (10 - 100 megohms). When on the other hand the reverse bias is reduced, the depletion layer retreats from the channel region and the resistance from source to drain becomes small (1-10 kohms). At the same time the gate is insulated from the source-drain by a reverse biased junction constituting a very high resistance (in silicon this is typically 100 megohms). In a sense, the unipolar transistor constitutes a voltage controlled relay, and as we shall see, may be used to build logic systems in much the same manner as relays are used. The high-frequency cut-off for a unit with the dimension shown in Fig. 3 is approx. 10 mc per second. The size of this transistor is 0.020" square. As

a comparison, the dot over the letter "i" in this text has a diameter of 0.017".

## BASIC BUILDING BLOCKS

Fig. 4 shows the *basic building block*. It consists of a unipolar transistor, a load resistor on the output side and a load resistor on the input side. As these basic building blocks



**SANFORD M. MARCUS** was born in New York, New York, on March 18th, 1932. He received his B.S. degree in physics from the Brooklyn College, Brooklyn, New York, in 1954. He then attended Columbia University, receiving the M.S. degree in 1957.

Since 1957 Mr. Marcus has been associated with RCA in Camden, New Jersey, where he is engaged in the development and application of semiconductor devices.



**J. TORKEL WALLMARK** received the degree of Teknologic Doktor from the Royal Institute of Technology, Stockholm, Sweden, in 1953. From 1944 to 1945 Dr. Wallmark was a tube designer with the A. B. Standard Radiofabrik, and from 1945 to 1953 he was with the Royal Institute of Technology as a research engineer working on electron tubes. He was also connected to Statens Tekniska Forskningsrad working on research administration and Elektrovarmeinstitutet working on semiconductors.

In 1947 and 1948 Dr. Wallmark was a fellow of the American-Scandinavian Foundation at RCA Laboratories. In 1953 he returned to the Laboratories and is presently working on integrated electronics.

\* Sponsored by Air Force Cambridge Research Center, Research Directorate, under Contract No. AF19 (604)—1957.

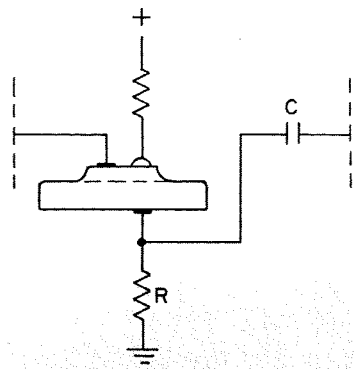

(a) CONVENTIONAL

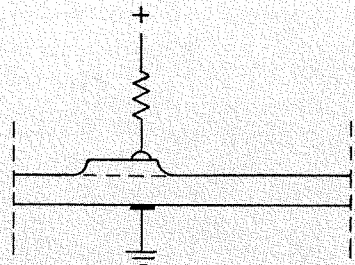

(b) INTEGRATED

Fig. 1—One Stage of Shift Register.

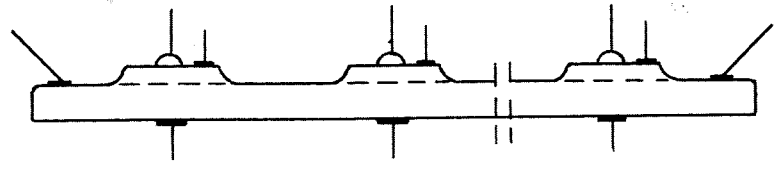

(a) SERIES CONNECTED

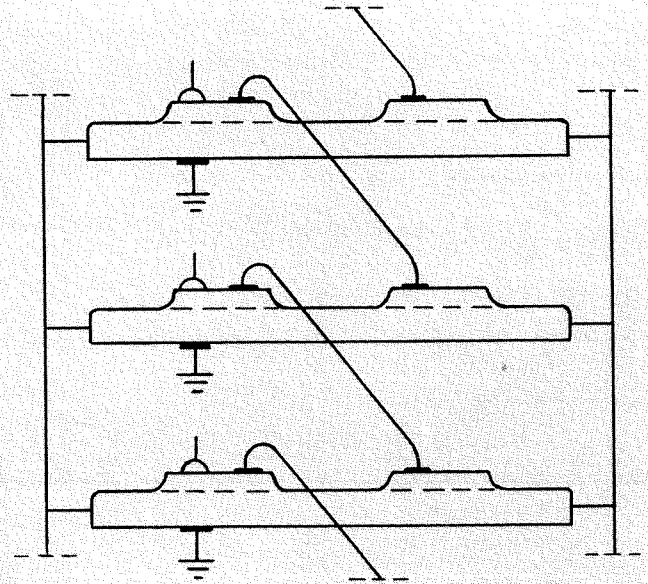

(b) PARALLEL CONNECTED

Fig. 2—Integrated Shift Register.

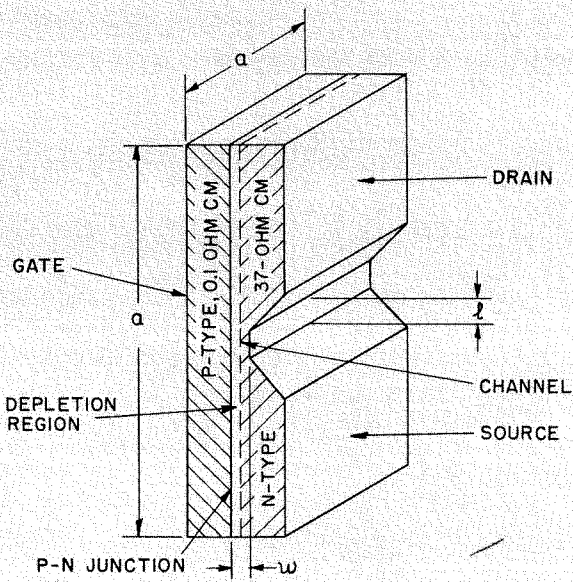

$a = 0.020''$   
 $l = 0.001''$   
 $w = 0.0005''$

Fig. 3—Unipolar Transistor.

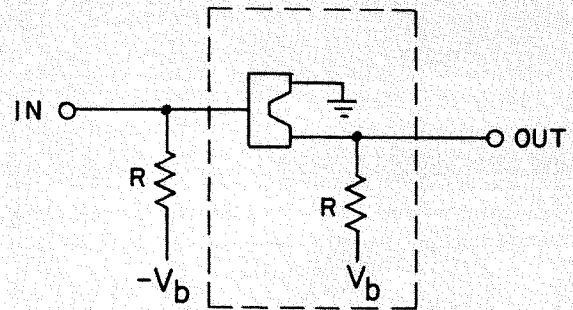

Fig. 4—Basic Building Block of DCUTL.



are intended to be used in arrays with a large number of units in series and parallel, the output resistor of one stage may be the input resistor of the next stage. For the most part, therefore, we need only consider one of these resistors, say the output resistor in the basic building block. The value of the load resistor is not too different from that of the channel resistance of the unipolar transistor. We may, therefore, substitute a second unipolar transistor for the load resistor, but with a channel width that is slightly smaller than that of the first unit to obtain the correct resistance value. The resistance of the unipolar transistor element is, of course, highly non-linear. However, such a non-linear load resistance is actually desirable in that it insures more positive switching action.

To obtain the final shape of the basic building block, we may perform the mental operation of letting the semiconductor elements increase in size, while the connecting metallic wire shrinks in size, until it is finally swallowed up by the semiconductor elements, so that the building block obtains the form shown in Fig. 5. In this form the building block is now an integrated device in the sense described in the introduction. The following figures show examples of use of this building block in various combinations, each one forming a logic circuit, such as is used in digital computers or automation equipment.

Fig. 6 shows a *multiple-AND circuit* consisting of four active and one passive unipolar elements. When no signal is applied to the input gate contacts, all the gates attain a large negative voltage shutting OFF all the elements. When one or more gates are driven to a less negative voltage, the corresponding channel resistances shift from a high to a low value and

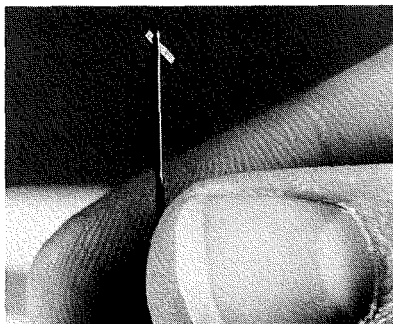

Multiple "AND" Circuit placed in the eye of an ordinary sewing needle.

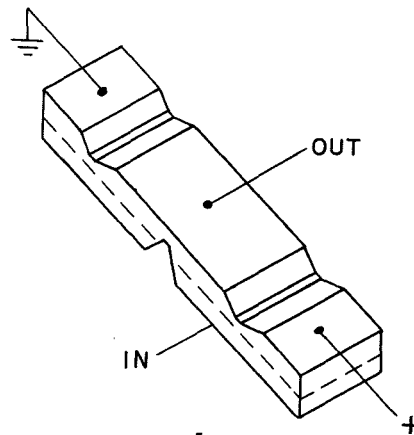

Fig. 5—Integrated Basic Building Block.

turn ON the elements. However, the output voltage will remain highly positive, OFF, until all the gates are biased to a small negative voltage, in which case the output voltage becomes a small positive voltage corresponding to ON.

One important requirement of the building block is that a pulse, passing from one end to the other, does not deteriorate but retains its shape and height. Analyzing a *series chain* of stages such as shown in Fig. 7, it is found that the voltages corresponding to ON and OFF are stable and propagate unchanged even throughout an infinite chain. What this means is that the unipolar element serves at the same time as a logic element and as an amplifier and limiter. One might fear that, if the unipolar elements act as amplifiers, noise at the input might be amplified, so that after a number of stages the noise might reach the level of the signal. However, the unipolar elements amplify only signals above a certain level and reject signals below that level so that noise remains at a low level even throughout an infinite chain. In the series chain of Fig. 8 alternate elements have complementary symmetry. N-type base elements alternate with p-type base elements, and the battery supply voltages alternate. This is to keep the junctions reverse biased at all times.

#### MORE COMPLEX CIRCUITS

To illustrate how the basic building block may be used in the synthesis of

more complex circuits, consider the *half-adder* shown in Fig. 8. This half-adder consists of three small pieces of silicon treated to contain a few active and passive unipolar elements each, all mounted on a thin piece of insulator carrying the printed-circuit connections between the elements and to the power supply. This half-adder can add two digits in the form of ON or OFF pulses, supplied to the two inputs, and deliver the sum and eventual carry as two output pulses. This function is conventionally carried out by a score of transistors, resistors and capacitors.

As an example of a still more complex circuit, consider Fig. 9 which shows a *transfer tree*, as is used for addressing different parts of a memory in a computer. This transfer tree is made up of 24 unipolar elements connected in eight rows of three elements each. The gates of the unipolar transistors are connected to three flip-flop circuits (not shown), which give a large negative bias to some of the gates corresponding to OFF, while the rest of the gates are given a small negative bias corresponding to ON. In this manner one, and only one, row of

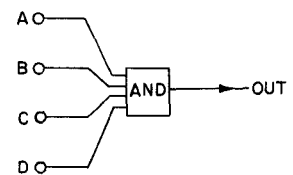

(a) RELAY SYMBOL

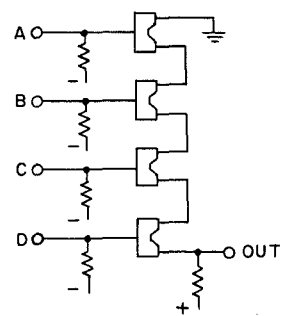

(b) DCUTL

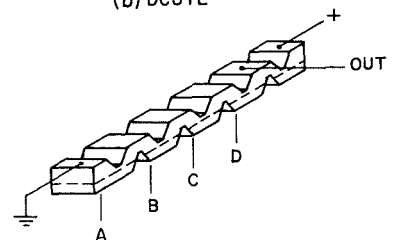

(c) INTEGRATED DCUTL

Fig. 6—Multiple-And-Circuit

unipolar elements will be all ON, connecting the input to one of the outputs, while all the other rows will have at least one element in the OFF condition, thus disconnecting all the other outputs. By setting the flip-flops in different states, the input may be connected to any one of the eight outputs. This principle may be extended to larger numbers, if desired. The load resistances which again would be integrated into the device are not shown in the figure.

In the same manner other logic circuits may be built. While those described above consist of only a few elements, it is believed that more complex networks can be built, perhaps

to the extent that the entire logic part of a digital computer may contain nothing but integrated devices, where small silicon elements are sandwiched between ceramic insulating wafers, and where the sandwiches may be stacked on top of each other. The entire computer would then be small enough and, probably, reliable enough, to justify hermetical encapsulation of the circuits in a number of small packages. The size of the package and the circuits contained therein would have to be decided from logistic considerations (such as life, failure rate, repair, spare parts, and cost).

The integrated devices, described this far, encompass rather simple cir-

cuit functions, such as that of a resistor or a simple RC-circuit. It has been shown, however, that more complex circuit functions, such as those of tuned circuits, may also be incorporated in integrated devices.

#### REFERENCES

1. E. W. Herold: "Future Circuit Aspects of Solid-State Phenomena", Proc. I.R.E. 45, 1957, p. 1463.
2. C. W. Mueller, J. Hilibrand: "The 'Thyristor' — A New High-Speed Switching Transistor", I.R.E. Trans. ED-5, 1958, p. 2.
3. J. T. Wallmark, S. M. Marcus: "Integrated Devices Using Direct-Coupled Unipolar Transistor Logic", to be published in I.R.E. Trans. Electronic Computers in June, 1959.
4. W. Shockley: "A Unipolar 'Field-Effect' Transistor", Proc. I.R.E. 40, 1952, p. 1365.

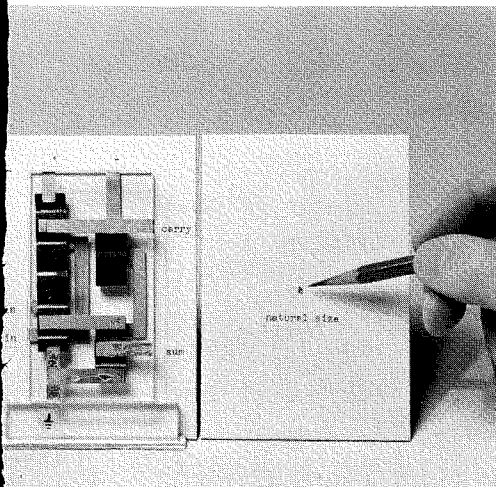

Half-Adder using DCUTL. Large scale mock-up with printed circuit at left. Natural size indicated at right.

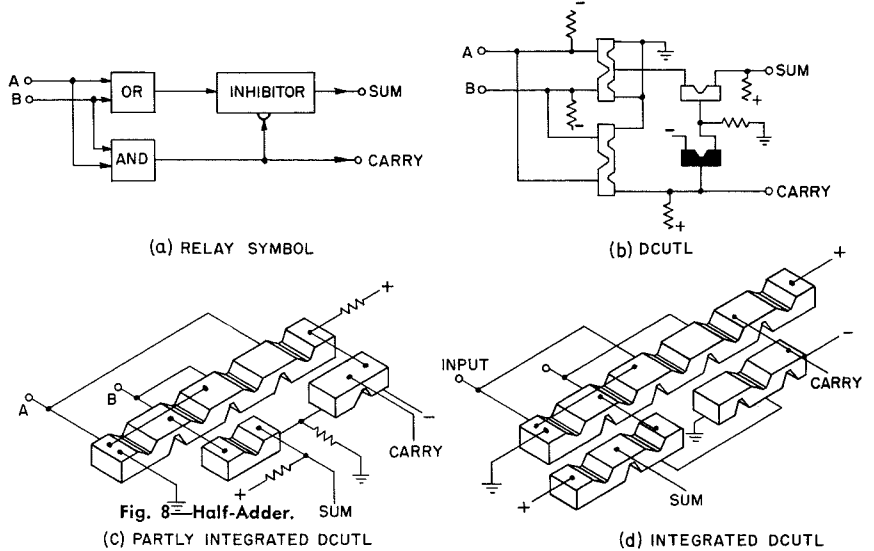

Fig. 8—Half-Adder.

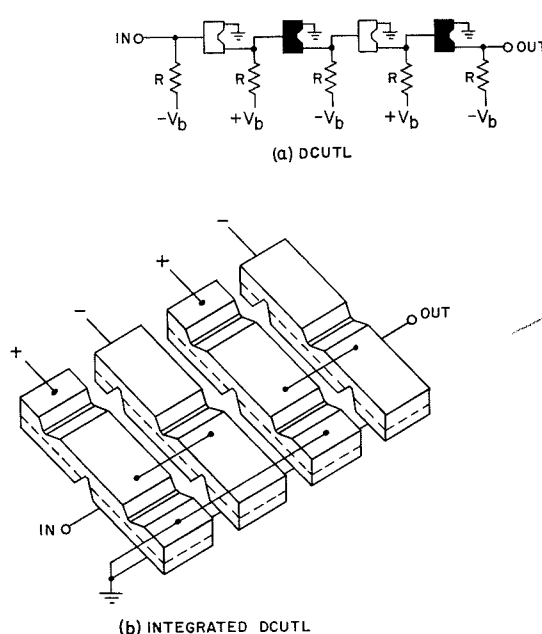

Fig. 7—Series Connection.

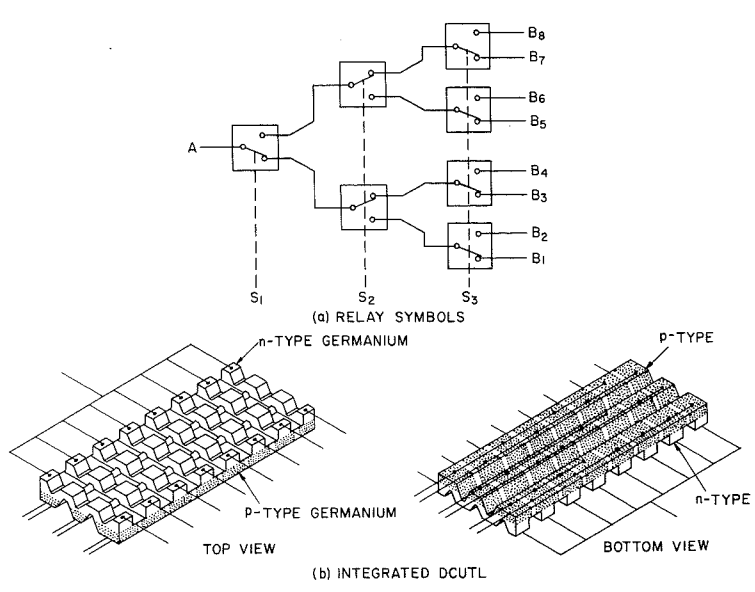

Fig. 9—Three-Stage Tree

# TUBES AND TRANSISTORS IN NON-ENTERTAINMENT-TYPE EQUIPMENT

by

G. G. CARNE, D. P. HEACOCK, R. B. JANES, and R. L. KELLY

**Editor's Note:** The authors of this paper have served as members of a committee to develop, for management guidance, material on the technical capabilities of tubes and transistors. This effort over the past year has included, in addition to work by the authors, significant contributions by Harwick Johnson (RCA Labs) and G. M. Rose (Tube Division).

EQUIPMENT DESIGNERS today are faced with the choice between tubes and transistors for many applications or circuit functions. To make such a choice logically, designers must consider the advantages and disadvantages of each device in a given usage. This paper discusses the use of tubes and transistors in various applications, and evaluates the current position and future technical potential of both devices in the area of industrial and military applications.

This evaluation deals with technical status and does not attempt to predict the rate of acceptance of tubes or transistors for various applications.

## NON-ENTERTAINMENT-TYPE EQUIPMENT

There are three major kinds of non-entertainment applications — industrial, computer, and military. As compared with entertainment usage, all of these applications require improved system reliability. In industrial and computer applications, tubes or transistors are generally required to provide very long life. Military applications are similar circuitwise to industrial and computer usage, but also involve severe size, weight, and environmental requirements.

Regardless of application, tubes or transistors perform three basic functions—they amplify, switch, or rectify. Thus it is necessary to evaluate these devices in terms of both specific application and circuit function.

## GENERAL CONSIDERATIONS

**Cost.** At the present time, a transistor generally costs more than a receiving tube for a given function, although transistor costs are rapidly decreasing and are approaching tube costs.

In non-entertainment-type equipment, however, unit tube or transistor cost is often less important than the overall cost of keeping a given system in operation. In general, this consideration favors the use of transistors despite their higher unit cost. It must be remembered, however, that in some applications more than one transistor must be used to perform the same function as one single-purpose tube.

**Uniformity.** At present, transistors show larger variations in gain and in input impedance than receiving tubes. Although it is expected that uniformity will improve, transistors are not likely to equal the uniformity of vacuum tubes within the next five years.

**Stability.** Each device offers greater stability in a particular field of applications. Tubes offer improved performance under conditions of appreciable temperature variation because transistors, in general, require special temperature compensation. Transistors are preferred when relatively

stable characteristics are required over long periods because transistor characteristics generally change less with life than vacuum-tube characteristics.

**Power Consumption.** In battery-powered equipment, transistors are preferred because they require no heater power. They are also advantageous in small-signal amplifiers because their sustaining current may be very small. In power-line-operated equipment and in power-amplifier circuits, the power saved by using transistors may be unimportant.

**Size and Weight.** Transistors can always be made smaller than vacuum tubes for a given current requirement because of the much higher current density possible in the active element. However, where appreciable power is to be handled, the combination of the transistor and a satisfactory heat sink may offset the advantages of the transistor. Development of the "Nuvistor" has shown that it is possible to make vacuum tubes which closely

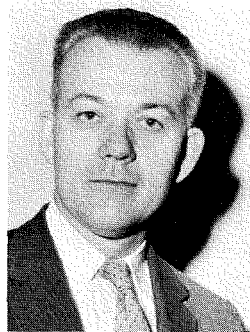

G. G. CARNE received the B.S. degree in Physics from Nebraska Wesleyan University in 1939 and the M.S. degree in Physics from Illinois Institute of Technology in 1941. He then joined the Receiving Tube Design Activity of the RCA Electron Tube Division and worked initially on development of VHF and UHF receiving tubes. His work included the initial design and development of "light house" and "pencil type" UHF triodes. In 1952 he was made Manager, Receiving Tube Design and a year later advanced to Manager, Receiving Tube Engineering. In 1954 he became Manager of a new Engineering Activity, Industrial Receiving Tube Development. In January 1959 he joined the Microwave Engineering Activity as Manager, Process Systems Development.

Mr. Carne is a Member of Sigma Xi and a Senior Member of the Institute of Radio Engineers.

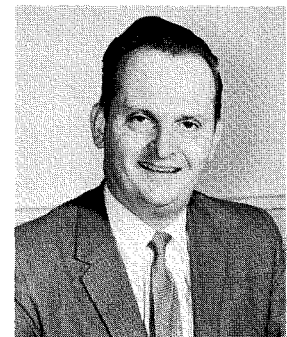

DAVID P. HEACOCK received the B.S. degree in Mechanical Engineering from Rutgers University in 1941. He received an M.S. degree in Electrical Engineering from the Stevens Institute of Technology in 1946.

In 1941 he was employed by RCA as an engineer in the Test Engineering Group. Here he worked on tube specifications and the development of tube test equipment. In 1946 he was transferred to the Application Laboratory where he worked on circuit problems involving the proper application of receiving tubes. In 1953 he became Manager of the Application Laboratory, and in 1955 was promoted to the position of Manager of Entertainment Tube Development. In 1956 he assumed his present duties as Administrative Engineer, Product Engineering.

Mr. Heacock is a member of Tau Beta Pi and Phi Beta Kappa, and a Senior Member of the Institute of Radio Engineers.

approach the present size of transistors. However, further reduction in transistor size is feasible since the device size is determined almost entirely by practical limits on size of enclosure.

With the development of increasingly complex electronic systems, in which a given circuit function is usually repeated many times, size will be at such a premium that long-range thinking tends to discard the concept of using individual tubes or transistors. The devices used in such systems must be adaptable to very small modules which will transcend traditional device functions and integrate circuit functions into a single unit. The variety of available phenomena and the homogeneity of the solid as a medium favor the transistor approach now under investigation at the RCA Laboratories. Devices of this type should be available for advanced development within a year.

#### MILITARY APPLICATIONS

**Shock and Vibration.** Transistors are inherently superior to tubes with regard to shock and vibration resistance because there are no critical mechanical spacings which must be maintained in a transistor. Transistor "spacing" is

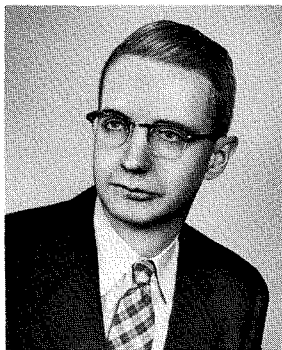

**ROBERT B. JANES** received the B.S. degree in physics from Kenyon College in 1928. He did graduate work in physics at Harvard and at U. of Wisconsin where he received a Ph.D. in 1935. From 1929 to 1931 he taught physics at Colgate U. and from 1931 to 1935 was research assistant at the U. of Wisconsin. From 1935 to 1943, Dr. Janes was an engineer at RCA, Harrison, N. J. where he worked on television camera tubes and phototubes. In 1943 he went to the Tube Division of RCA at Lancaster, Pa. He was in charge of the development and design of television camera tubes until 1950 when he was appointed Manager of the Development Group responsible for camera tubes, storage tubes, and phototubes. In 1953, he was appointed Manager, Color Design, of the Color Kinescope Engineering activity. He became the Manager of the Design activity in the Semiconductor Division in 1956. Dr. Janes is a member of Sigma Xi and a Fellow of IRE.

developed within the transistor assembly and cannot be changed unless the assembly is fractured. The low mass and ease of support of this assembly make it possible to produce transistors which are capable of withstanding extreme values of shock and vibration. However, tubes are also being produced which are extremely resistive to the effects of shock and vibration and adequately meet the current requirements of the military.

**Temperature.** In certain military applications, electronic equipment must operate in an ambient temperature as high as 500 degrees centigrade. At present, vacuum tubes employing ceramic envelopes are available which are capable of operation at this temperature. There is, however, a wide field of application where temperature requirements are not so extreme. Conventional tubes are capable of operation at a bulb temperature of about 250 degrees centigrade without change in characteristics. Tubes made with special glass envelopes can be operated at a bulb temperature of 300°C.

Germanium transistors are useful up to approximately 100 degrees centigrade, and silicon transistors are available which will operate at 200 de-

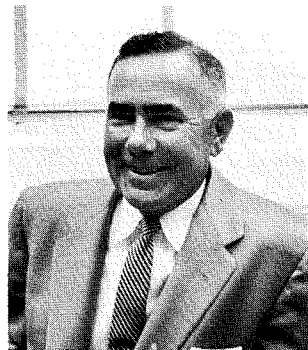

**ROBERT L. KELLY** received the B.E. degree from Johns Hopkins U. in 1929. He joined the A. Atwater Kent Company in 1930, and spent the following six years designing radios for home, automobile, and farm. In 1936, he joined RCA as an application engineer in the Electron Tube Division at Harrison. He moved up to Manager of Application Engineering in 1946. He was appointed Administrator of General Quality Control of the Division in 1952, and in 1955 was appointed Manager of Customer Service Engineering. In 1957 he was promoted to his present position of Technical Coordinator for the Commercial Manager of the Electron Tube Division.

Mr. Kelly is a Senior Member of Institute of Radio Engineers and a member of Tau Beta Pi.

grees centigrade. Within two years, silicon transistors capable of operation at 300 degrees centigrade could be released for production. Operation of transistors at temperatures up to 400 degrees centigrade will require the use of new semiconductor materials, possibly gallium arsenide. Under a highly accelerated program, development of this device to the point of production could be completed in about three

Converter  
(drift transistor)



Subminiature twin triode (high-altitude, high-temperature applications)

years. All semiconductors show an inherently greater change of characteristics with changing temperature than do tubes.

**Nuclear Radiation.** At the present time, vacuum tubes are inherently less susceptible to radiation damage than transistors. Although it is known that certain glass envelopes deteriorate during radiation, it is felt that ceramic and perhaps other glass envelopes will suffer no damage. The tube cathode appears to suffer no permanent damage as a result of radiation. Tube operating parameters are affected during radiation, but tubes recover when radiation is removed.

Transistors, on the other hand, can suffer permanent damage as a result of the effect of radiation upon their basic nature. This effect is fundamental, but is being minimized by suitable design modifications.

**Reliability.** Many military applications require extreme equipment reliability for short periods of operating time. Transistors appear to be superior to tubes in this type of application because of their greater freedom from early-hour mechanical-type failures. Tubes are being significantly improved, however, by improved assembly and processing techniques.

## COMPUTER AND INDUSTRIAL APPLICATIONS

*Operating Life.* Available data on the actual life which is being obtained from transistors indicate that it is an order of magnitude better than that of presently used tubes. Both tubes and transistors can provide extremely long life when they are made carefully and used conservatively.

*Ability to Switch.* For signal switching at voltages under 100 volts, transistors are preferable to vacuum tubes because of their almost negligible internal voltage drop. Switching speeds of up to 10 megacycles (10-megacycle repetition rate, rectangular pulse) are presently adequate for almost all applications and can be handled by currently available transistors. Vacuum tubes must generally be used for higher-voltage switching applications, although the system can often be modi-

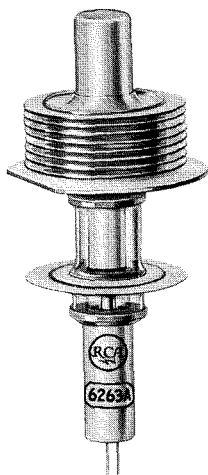

Pencil Tube with external radiator (uhf triode)



Miniature twin triode for switching applications

fied to permit the use of lower voltages and the adoption of transistors. Operating speeds in excess of 10 megacycles present difficulties because of limitations external to either a tube or transistor. Active work is under way to increase operating speeds, and tubes, transistors, and other devices are being considered.

At the present time, vacuum tubes are capable of delivering more useful power output than transistors in power-switching applications such as core drivers. However, the low internal loss in a transistor makes it possible for a transistor to control power up to a level of about 1000 watts if the voltage is limited to about 100 volts.

The power-handling capability of vacuum tubes is relatively independent of frequency. Although transistor power-switching devices are currently limited to switching rates up to about 10 kilocycles, this frequency is adequate for most applications. It will be possible within about three years to increase this frequency for power switching to about 1 megacycle.

## AMPLIFIER APPLICATIONS

*Input Impedance.* In some amplifier applications, it is desirable that the amplifier have a high input impedance. Vacuum tubes satisfy this requirement easily. Although transistors have been made of the unipolar type which have the property of high input impedance, no active product development is going on at this time.

For other amplifier applications, the input impedance of the amplifier may be in the order of 500 ohms or less. In such applications, a transistor provides higher input stage gain than a vacuum tube.

*Noise.* The inherent noise in either tubes or transistors at a given frequency is approximately the same. The transistor, however, is inherently free from microphonics. The vacuum tube can be made with satisfactory microphonics characteristics for almost any application. Other noise effects due to stray electron emission, leakage, and the like which are sometimes present in vacuum tubes have their counterparts in transistors. Control is required, therefore, to avoid trouble with either device.

*D-C Amplifiers.* Both tubes and transistors have limitations in d-c amplifiers. Transistor characteristics change because of variations in ambient temperature. Vacuum-tube characteristics drift because of changes in contact potential and cathode emission. With careful circuit design, however, either device may be used effectively.

*A-C Amplifiers.* In narrow-band systems, tubes provide higher stage gains than transistors at all frequencies. In general, therefore, more transistors than tubes are required to produce a given system gain. In wide-band systems, such as video amplifiers, tube and transistor gains are more nearly alike and may be directly comparable if the transistor capacitances can be made lower than tube capaci-

tances for equal mutual conductances.

The ultimate frequency limit for either device as an amplifier is that frequency at which it will just oscillate. This limit is about 10,000 megacycles for conventional tubes and about 2500 megacycles for transistors. Useful amplification of 8 to 10 db per stage is realizable at about one-third of these frequencies, i.e., approximately 3000 megacycles for tubes and 800 megacycles for transistors.

## SWITCHING APPLICATIONS

As mentioned previously in the discussion of computer and industrial applications, transistors are preferred in low-voltage switching applications, but vacuum tubes are preferable when the applied voltage exceeds 100 volts.

## RECTIFIER APPLICATIONS

In low-level applications where voltages are low and current requirements are of the order of several milliamperes, semiconductor diodes have almost entirely replaced vacuum tubes. The small size, low voltage drop, and zero standby power of semiconductor diodes have made them very attractive.

In high-power vacuum-tube circuits, tube rectifiers have been generally used to provide operating voltages. Silicon power rectifiers are now available which can provide power at operating voltages up to about 500 volts d-c. These silicon rectifiers are making inroads on vacuum-tube usage in such applications.

In equipment using large quantities of transistors, low-voltage, high-current power will be required. Because of their low internal drop, silicon rectifiers are ideally suited for such equipment.

## TEMPERATURE AND FREQUENCY

There is almost no frequency-temperature relationship which exists as a limitation in tubes. In transistors, however, the two attributes are closely related.

In germanium devices, as in all transistor materials, holes and electrons have a certain mobility and can attain a certain velocity in moving through the semiconductor. These velocities are much less than those attained by electrons moving freely in the vacuum of an electron tube. This effect limits the maximum operating frequency of a germanium transistor. Useful gain as an amplifier can be obtained from



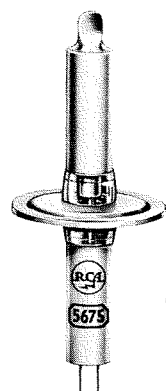

Pencil Tube  
(uhf Triode)



Silicon  
Rectifier



a-f Amplifier  
(transistor)

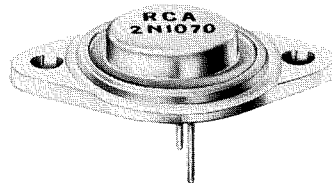

Silicon "mesa"  
power transistor

a germanium transistor up to about 800 megacycles. The maximum frequency at which such a transistor has just enough gain to keep itself oscillating is about 2500 megacycles.

The above figures are applicable only at room temperature. At 100 degrees centigrade, the maximum frequencies must be reduced to about 80 per cent of the values given above. Germanium transistors cannot be operated above 100 degrees centigrade because the electron activity within the germanium becomes so high that the material begins to have the properties of a conductor rather than a semiconductor.

Silicon can be operated at temperatures as high as 300 degrees centigrade before it loses its semiconductor properties. Its mobility is lower than that of germanium, however, and maximum operating frequencies at room temperature are only about one-third those of a germanium transistor made with similar spacings. As the temperature is increased, mobility decreases in silicon just as it does in germanium.

The maximum frequency at which a silicon transistor can give useful amplification at 300 degrees centigrade is approximately 75 megacycles. Maximum oscillator frequency is 300 mc.

Gallium arsenide has a mobility similar to that of germanium, but retains its semiconductor properties up to a temperature of approximately 450 degrees centigrade. As in the other materials, performance deteriorates with increasing temperature. At 450 degrees centigrade, gallium arsenide transistors will not provide useful amplification above about 100 mc.

The above discussion applies to transistors used in applications where the output required is relatively low and dissipation within the semiconductor can be neglected. As increasing amount of useful power output are required, the problem of temperature and frequency becomes further involved because of locally generated heat within the transistor.

#### AUTOMATION

Ultimately, the ability of either tubes or transistors to exist with the other will depend upon the ease with which they can be fabricated, which greatly affects costs and quality. Although it may appear that the transistor is a more simple device to automate, it should be remembered that it is basically a different device. Most of the problems in the mechanization of tube assembly are mechanical and can be easily visualized. Most of the problems in the fabrication of transistors are essentially problems of process control in which the goal will be to achieve "spacings" which are several orders of magnitude smaller than the spacings used in vacuum tubes. The degree to which the tube industry and the semiconductor industry are able to overcome these problems will in large part dictate the rate at which transistors will be adopted.

#### CONCLUSIONS

Today, transistors offer advantages from the standpoints of size, weight, freedom from microphonics, resistance to shock and vibration, and power consumption. Tubes offer advantages from the standpoints of cost, uniformity, maximum operating frequency, maximum operating temperature, and stability with changes in temperature.

Semiconductor materials impose certain frequency and temperature limitations upon performance which are not present to the same degree in electron tubes. Thus, tubes offer performance advantages today in applications where operating ambient temperatures exceed 200 degrees centigrade and operating frequency exceeds about 200 megacycles. For more normal frequencies and environments, a wide variety of tubes are available to operate at a variety of power levels and frequencies. Transistors can presently provide about 3 watts of power at 100 megacycles at room temperature.

For the future, further improvements are contemplated in both tubes and transistors to improve high-temperature and high-frequency performance. A tube capable of operation in ambient temperatures up to 500 degrees centigrade can be demonstrated at present and released for production in one to two years. Such a tube would be a useful amplifier up to about 1000 megacycles. A transistor which should operate in ambient temperatures up to 400 degrees centigrade and provide useful amplification at frequencies up to 100 megacycles is being developed. Under a highly accelerated program, this device could be developed to the point of production in about three years.

Improvement of the transistor will come steadily in the direction of providing more power at higher frequencies. It is expected that within three years it will be possible to obtain 1 to 2 watts of power at 200 megacycles and 5 to 10 watts of power at 100 megacycles from commercially available transistors.

Ultimately, it can be expected that transistors will be able to meet the requirements of most applications where receiving tubes are currently used. The degree to which tubes and transistors will coexist will then depend upon the economy and performance which can be obtained from each device. Achievement in this area will depend upon the ingenuity with which tube and transistor engineering groups can reduce to practice those ideas which lead to greater mechanization, better assembly techniques, and greater reliability and uniformity.

# MILITARY OPERATIONS RESEARCH

by

**MONES E. HAWLEY, Mgr.**

*Operational Planning  
Missile Surface Radar Dept.  
Moorestown, N. J.*

THE QUESTION IS frequently asked, "What is the difference between Operations Research and systems engineering?" Certainly there is no clear dividing line between the two disciplines and no widely-accepted definition of the distinction. In DEP, though, there are some readily-observable differences even though systems engineers and O.R. specialists work side by side.

The work of the O.R. groups is concentrated on the very beginning and the very end of a project, while the systems engineering portion is heaviest in the middle range. The O.R. people are far more likely to discuss the need for a new system and the validity of its specifications with the faculty of a service war college, for instance, or to participate in the evaluation of system performance on field maneuvers and command post exercises. The O.R. approach is usually extensive rather than intensive, dealing primarily with exterior characteristics and inter-relationships of a system rather than with its internal compatibility and behavior. The O.R. view is an extremely broad one in which strategic doctrines and objectives, tactical deployments and attack configurations, and support activities such as manpower training cycles, logistics plans, and economic resources all play important roles.

Both systems engineers and O.R. specialists are dedicated to establishing and maintaining the integrity of a system. The systems engineer concentrates on the compatibility of the parts of the system, while the O.R. man concentrates on the ability of the system to meet a military need. This paper explains how an O.R. group functions in approaching its task through system planning.

## **FUNCTIONS OF OPERATIONS RESEARCH**

Two items are usually emphasized when the functions of an O.R. group are described; first, the results the group furnishes should be quantitative, and second the work should be in support of managerial decision making. A group meeting these criteria still may operate at different levels on different kinds of problems and with different objectives. For example, in industrial O.R. the emphasis has been placed on cost reduction through improved production, purchasing, stocking, and distribution. During

World War II O.R. was used in the armed forces of Britain and the U.S. to solve problems dealing with making the best use of existing equipment and manpower. These studies became the classics of military O.R. and are representative of much work still done by O.R. groups within the Department of Defense.

However, in DEP and several other similar organizations we have changed the role of military O.R. somewhat, for we believe that the most effective use of a limited number of O.R. specialists is in helping Engineering and Marketing, particularly in the planning phases of new large systems projects.

In participating in planning our O.R. specialists enjoy an advantage denied to earlier researchers. It is felt that a small, experienced O.R. group can anticipate operational evaluation and utilization problems early in the program and, by influencing the system design, accomplish far more than a large O.R. group trying to make best use of a system already produced and deployed.

## **MEASURES OF EFFECTIVENESS**

The fundamental problem for any military O.R. group is to determine how well a system fits its operational environment. One part of this environment is the enemy threat including his strategy, tactics, weapons, bases, manpower, and money. Another part is the physical environment—such factors as weather, radiation, climate, and terrain. Still another factor is our own military posture including coordination with other systems, our manpower, our economy, and our military objectives. The final major factor is time which enters in three ways, in terms of readiness, in terms of effective life in combat, and as calendar time for one must be sure that comparisons are made between systems which are operational in the same time period.

The *measure of system effectiveness* is the quantitative description of the match between system performance and the operational environment. Most of O.R. effort is directed toward developing these

measures and in calculating appropriate values for them. The effectiveness of alternative system configurations, modes of operation, deployment schedules, or means of tactical employment are examined to determine the appropriate trade-offs between the critical commodities, usually money, manpower, facilities, and time. The best compromise usually depends heavily on the initial selection of factors to be included in the measure of overall system effectiveness. Frequently more than one measure must be used to include all the critical performance factors; sometimes the O.R. specialists find that there are factors which they are completely unable to include other than as qualitative notes. Generally these factors are political, psychological, or sociological and cause the O.R. group to wish that the techniques of measurement were further developed in these difficult fields.

## **THE IMPORTANCE OF BACKGROUND MATERIAL**

It is apparent, though, that to perform a good O.R. evaluation of a new system one needs a considerable background of studies and assessments. Usually, there is insufficient time to collect these background data after a project has begun; one has time only to apply what he already knows to the particular project with some last minute brushing up in critical areas. Thus a considerable part of an O.R. man's time is spent in collecting, analyzing, and developing information which may not be useful for some time. The collection of this background of knowledge requires considerable imagination and good judgement, for the accuracy of the later analyses will be determined by the accuracy of the basic background data.

Sometimes a good basic understanding of the military situation will permit a quick and accurate evaluation of the worth of a proposed system. Consider a recent case involving a new Army system. The request-for-quote included the required military performance characteristics and intended operational dates. A very preliminary system synthesis yielded a rough system cost.

An examination of data collected on earlier investigations of related Army areas gave estimates of the deployment,

the contemporary threat, and the size of available funds. An O.R. specialist compared these data and concluded that the Army could not afford to buy enough of the equipments adequately to cope with the threat unless a considerably less expensive system could be designed. On the basis of this information RCA decided not to bid. Subsequent reports indicate that this decision was sound, for it appears that the Army will not support the program.

A broad background of experience also facilitates a considerably deeper insight into the basic factors in system planning. For instance the growth program of a system must take into account not only changes due to the passage of time and improvements in the military art, but also should make provision for the feedback changes in strategy, tactics, and equipment that results from the system's being installed in the first place.

An understanding of the fundamental

ideas of strategy and tactics permits consideration of the relative limitations of the three defenses against electronic countermeasures, i.e., fixing up one's own system, destroying the source of ECM, and creating a situation in which the enemy is deterred from using his capability. The last is obviously the most desirable and at the same time is the most difficult. Another example requiring broad background knowledge is the comparison of the relative worth to a given system of the five passive means of reducing vulnerability to an attack; concealment, mobility, dispersal, deception, and fortification.

#### REQUIREMENTS FOR O.R.

DEP has concentrated its O.R. on planning work, partly because trained manpower in O.R. is in short supply. The basic requirements for an O.R. man are: considerable military or design and development engineering experience;

an advanced knowledge of mathematics, physics, and engineering science; great breadth of interest and viewpoint; imagination and creativeness; and facility in communicating formally and informally, verbally and in writing. As more O.R. men become available the scope of their work will broaden. Two or three years ago a large complex system was evaluated in the field with no O.R. support because none could be spared.

On BMEWS the large O.R. planning effort during the first year of system delineation has been followed by the creation of a smaller O.R. activity within the BMEWS project organization. Their principal objective is to refine and improve the overall measures of system effectiveness so that the operational evaluation exercises will be more meaningful. The demand for O.R. men on this and other programs throughout DEP is an indication of the value of the discipline.

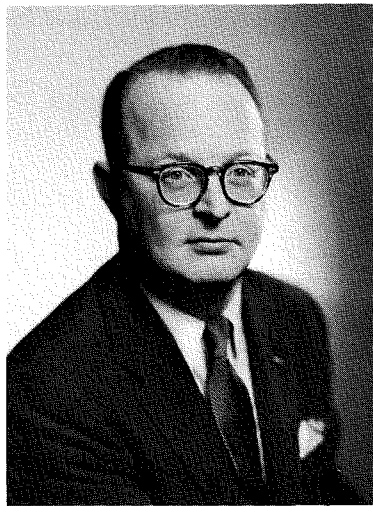

**MONES E. HAWLEY** received B.S. and M.S. degrees in Physics and Mathematics from the University of Rochester and has studied at M.I.T. and the University of Pennsylvania. During World War II he was a navigator-bombardier in the USAAF. He was a junior physicist in the research department of Stromberg-Carlson Co. before joining the Government Sound Section of RCA in 1948. At RCA in Camden he worked on microphones, speech communication systems, noise surveys, psychological acoustics, and bombing and navigation systems. In 1956 he was transferred to the Missile and Surface Radar Department where he directed the Operations Research activity on the Talos and BMEWS programs. He is now Manager of Operational Planning.

He is the author of twenty-five scientific papers and holds eight U.S. patents. He is a Fellow of the Acoustical Society of America, Senior Member of the I.R.E., and member of the Econometric Society, the Institute of Navigation, and the Operations Research Society of America.

#### Editor's Note:

At last meeting of Acoustical Society of America Mones E. Hawley was elected Fellow for his contributions to psychological acoustics, instrumentation, and speech communication systems. Mr. Hawley becomes the fourth Fellow among RCA scientists. The others are Dr. H. F. Olson, H. E. Roys, and J. E. Volkmann.

# PACKAGE ENGINEERING AND ITS RELATION TO PRODUCT DESIGN

by

I. M. REHM

Package Engineering  
Color Tube Development Shop  
Electron Tube Division  
Lancaster, Pa.



To the Product Design Engineer . . . Don't Forget—It must be shipped!

**S**OUND PRODUCT DESIGN and sound package engineering go hand in hand. In many cases an inherently rugged product needs extravagant protection in shipment because of its design. Packaging should not be required to compensate for weaknesses in the product itself, any more than a well-designed product should be endangered by inadequate packing. A product should be designed so that it can be easily and economically packaged, as well as easily and economically manufactured. Of course, it is necessary to strike a balance between the cost of making the product itself rugged and the cost of providing a

rugged package for the product. The time to strike this balance is while the product is still in the design stage.

## PRODUCT CHARACTERISTICS

From the standpoint of the package engineer, the important characteristics of a product are its size, shape, weight and "g" factor. The "g" factor is the amount of acceleration the product can withstand in any plane without damage. These characteristics determine not only the cost of providing adequate packaging for the product but also the cost of shipping it. For example, under Railway Express Classification No. 36 (Electron Tubes),

cathode-ray tubes not exceeding 24 inches and power tubes not exceeding 7 inches in greatest dimension, are charged the First Class shipping rate. However, cathode-ray tubes exceeding 24 inches and power tubes exceeding 7 inches in greatest dimension are charged double the First Class rate. It is evident, therefore, that the degree of attention given by the design engineer to the over-all dimensions of a product can significantly affect the cost to both the manufacturer and the purchaser.

## WHEN TO START

Study of a product from the handling and packaging standpoints should start before the design of the product is fixed. One of the first things that should be determined is the amount of abuse the product can withstand without packaging or other protection. A product may safely survive drop tests but be broken up during transit by vibrations which coincide with the natural period of the product in its package or with the natural period of some structural feature of the product itself. Unless the "g" factors of a product are known, packaged samples of the product must be dropped or vibration tested until breakage occurs. Such tests, however, do not directly indicate the amount of additional protection needed to prevent the product from breaking. Furthermore, if no damage occurs, there is no way of telling from such tests how much stronger than necessary the package is.

## HOW TO DO IT

The design engineer must determine such harmful frequencies, maximum permissible deceleration or maximum permissible shock for the unpackaged, unprotected product, by means of precisely regulated drop and vibration tests. He must then carefully analyze the product and establish a "g" factor for each plane.



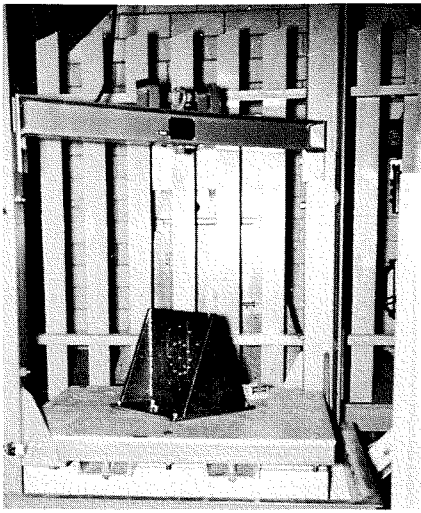

Fig. 1—Drop-test machine. The product to be tested is attached to a platform and then dropped from successively greater heights until breakage or failure occurs.

Fig. 1 shows one type of equipment used for drop tests. The product is secured to platform which is raised a predetermined distance and subjected to a free fall. The product is then tested and, if it functions properly, is subjected to additional drop tests from successively greater heights until it fails.

Fig. 2 shows a vibratory "exciter" used to determine the frequencies against which the product must be guarded in handling and shipment.

Fig. 3 shows the indicator units of a device used to determine the degree of shock required to break unpackaged products and to study the cushioning properties of complete packages. In this device, a quartz-crystal accelerometer is mounted on the product under test, which is then subjected to



increasing shock or vibration until breakage occurs. The crystal picks up all the shocks the product receives and converts them into electrical impulses, which are amplified and displayed as vertical deflections of a trace on an oscilloscope screen. The trace can be expanded both horizontally and vertically so that the impulse produced by each shock can be readily analyzed. This device makes it possible to determine quickly the types of shock which are most likely to cause damage to product. It also makes it possible to determine the limiting shock the product can sustain from the shock intensity immediately before breakage.

If he knows the "g" factors of the product, the packaging engineer can then compute the correct displacement for the product in the package and determine the type and amount of cushioning needed. Knowledge of the "g" factors also enables the packaging engineer to use scrap products or dummies in drop and vibration tests with the accelerometer. It should be emphasized that accelerometer tests do not provide solutions for all package design problems because of the many variables that may be involved. These tests do, however, provide a starting

Just a few of the myriad of shapes and sizes of cartons needed to accommodate complex electronic equipment. J. L. Parvin, Art Director for the RCA ENGINEER and a member of Corporate Staff Marketing Services is responsible for maintaining the attractive "family styling" achieved in RCA's Carton Program.

**IRWIN M. REHM** received his education at the University of Texas, the University of Alabama, and Franklin and Marshall College in Lancaster, Pa. He has also completed numerous special courses in package engineering at Forest Products Laboratory, IIT Campus, AMA Packaging Symposiums, and the like. He became interested in packaging design work while working at W. T. Grant Company as a merchandising trainee in 1935, and this interest became the foundation for his future work in this field. Prior to joining RCA in 1943 as a packaging engineer, he was Manager of Simplex Paper Box Corp., Lititz, Penna. He is currently in charge of Package Engineering for the Color Tube Development Shop of the Electron Tube Division in Lancaster, Pa.

Mr. Rehm is active in JEDEC packaging work, was Chairman of the Sub-committee on TV bulb and tube packaging from 1946 to 1955, and is currently Chairman of the Task Force on Performance Testing. He is a member of the Society of Industrial Packaging and Materials Handling Engineers, having served as President of the Central Pennsylvania Division and, in addition, as a member of the Board of Directors of the National Group. He was Chairman of the recent Temple University SIPMHE short course on bulk packaging practices.

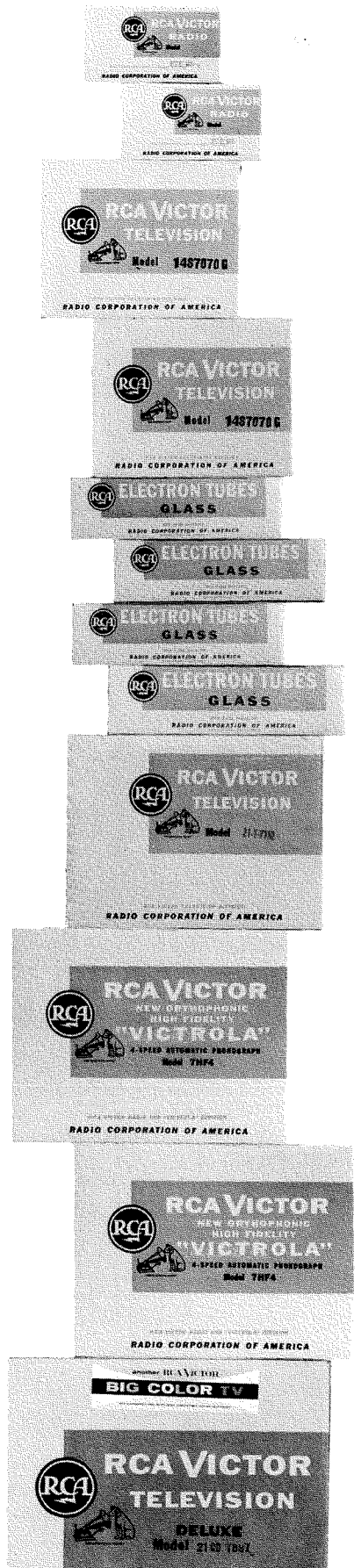



point for the packaging of a new product. Without some idea of the strength of the product, the correct packing method must be determined by "hit or miss" methods requiring the destruction of many expensive product samples.

#### TESTING THE FINISHED PACKAGE

Fig. 4 shows a vibration-testing machine at the RCA Package Laboratory in Camden. This machine can simulate any of the vibrational forces, motions, bumps, jars, resonances and other stresses likely to be encountered by packaged products in transit.

Fig. 5 shows a "CONBUR" incline impact-testing machine also used at the Camden Laboratory. This device makes it possible to determine the effects on large, heavy packages of sudden stops and shifts of cargo such as are likely to occur in freight cars, trailer trucks, airplanes and steamships.

#### PACKAGE AND WAREHOUSING COST

From knowledge of the size, shape, weight and "g" factors of a product before its final design is fixed, the packaging engineer can determine whether or not packaging, warehousing and transportation costs will be in line with accepted standards for that type of product.

#### FUTURE PROSPECTS

A close correlation between package

Fig. 2 — Vibratory exciter used to determine potentially dangerous mechanical resonances in a product.

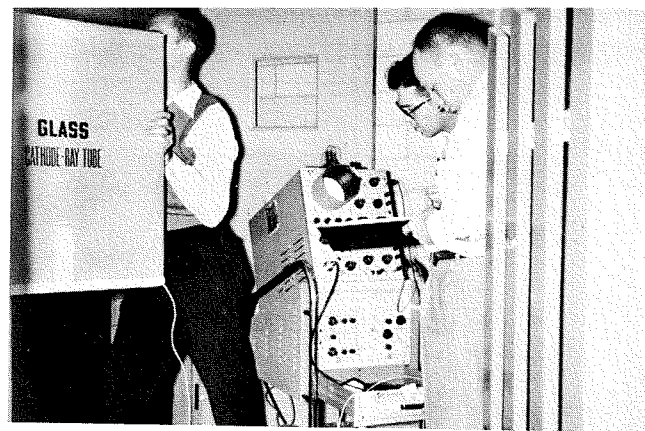
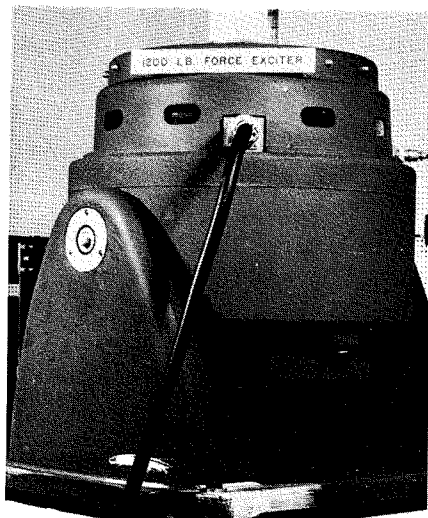

Fig. 3 — Indicating equipment used to analyze shock waveforms produced in accelerometer tests of packaged and unpackaged products.

engineering and product design is now being tried on a limited basis at the Lancaster plant of the Electron Tube Division. The cooperation and results achieved thus far in this program indicate that it should be possible to establish the relationship of the two fields on an exact, scientific basis.

The cost of packaging, warehousing and transportation, the loss of customers and good will as a result of un-

necessary damage, the waste involved in needlessly expensive packaging — all make it very desirable that we carefully evaluate product design in terms of package design.

REMEMBER—*"All Manufacturing, Engineering and Quality efforts are in vain if the product reaches its destination in a damaged condition."*

(National Safe Transit Slogan)

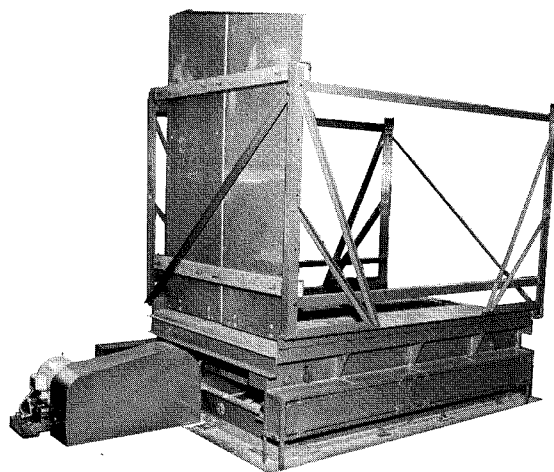

Fig. 4 — Vibration-testing machine which can simulate practically any type of stress to which a package in transit may be subjected.

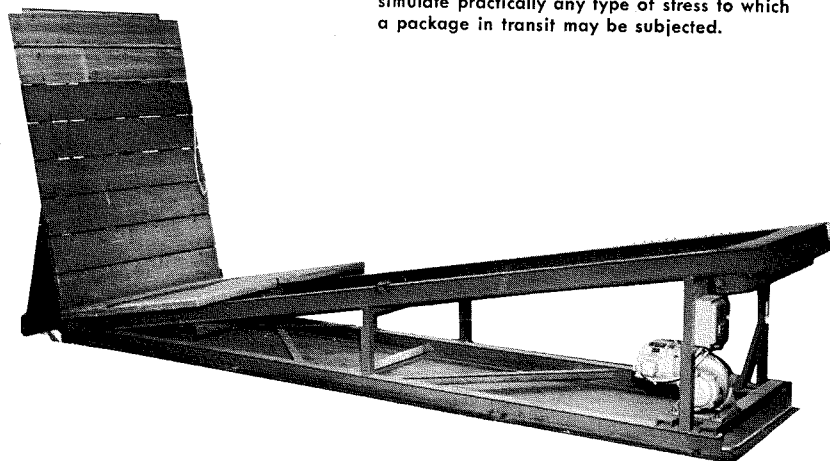
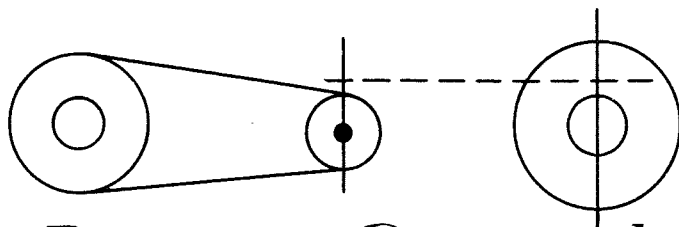
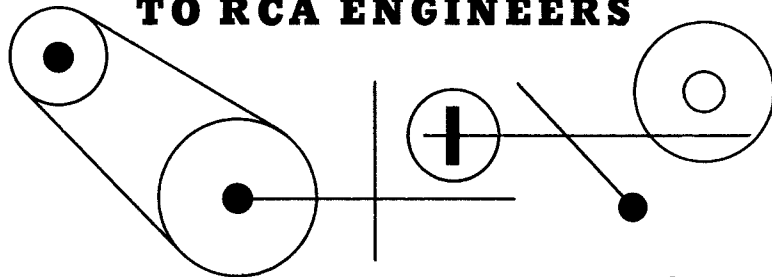

Fig. 5—Impact-testing machine, used to determine the effects on packaged products of sudden stops and cargo shifts which may occur in land, sea and air transport.



# Patents Granted TO RCA ENGINEERS



BASED ON SUMMARIES RECEIVED OVER A PERIOD OF ABOUT TWO MONTHS

## DEFENSE ELECTRONIC PRODUCTS

Moorestown, N. J.

**Radar System Having Antenna Rotation and Transmitter Keying Precisely Synchronized**

Pat. No. 2,876,446—granted Mar. 3, 1959 to N. I. Korman and W. V. Goodwin, no longer with RCA.

**Modulation or Gain Control System and Method**

Pat. No. 2,883,626—granted Apr. 21, 1959 to H. M. Scott.

Camden, N. J.

**Magnetic Recording System**

Pat. No. 2,881,255—granted Apr. 7, 1959 to J. R. Hall.

**Memory System**

Pat. No. 2,882,517—granted Apr. 14, 1959 to C. S. Warren.

**Cathode Ray Tube Systems**

Pat. No. 2,885,463—granted May 5, 1959 to J. S. Rydz.

**Static Magnetic Delay-Line**

Pat. No. 2,886,799—granted May 12, 1959 to H. N. Crooks.

**Automatic Soldering Apparatus**

Pat. No. 2,887,078—granted May 19, 1959 to C. H. Willis.

**Reduction of Ghost Images in Television**

Pat. No. 2,888,515—granted May 26, 1959 to K. Solomon and R. C. Abbett, IEP, Camden, N. J.

## ELECTRON TUBE DIVISION

Harrison, N. J.

**Method of Treating Glass**

Pat. No. 2,877,143—granted Mar. 10, 1959 to J. L. Gallup.

**Self-Pulsing Traveling Wave Tube Circuits**

Pat. No. 2,878,385—granted Mar. 17, 1959 to P. Koustas.

**Tweezer-Type Welding Apparatus**

Pat. No. 2,882,386—granted Apr. 14, 1959 to H. Hermann.

**Electron Tube**

Pat. No. 2,884,554—granted Apr. 28, 1959 to W. E. Lynar and W. J. Helwig.

Lancaster, Pa.

**Processing of Electron Tubes Containing Luminescent Screens**

Pat. No. 2,877,605—granted Mar. 17, 1959 to S. A. Harper.

**Photosurface**

Pat. No. 2,880,344—granted Mar. 31, 1959 to R. G. Stoudenheimer.

**Composite Photoconductive Layer**

Pat. No. 2,881,042—granted Apr. 7, 1959 to F. D. Marschka and J. E. Kuehne.

**Electron Multipliers**

Pat. No. 2,881,343—granted Apr. 7, 1959 to J. J. Polkosky and A. M. Splinter.

**Pneumatic Electrical Connector**

Pat. No. 2,883,638—granted Apr. 21, 1959 to J. T. Mark.

Camden, N. J.

**Variable Voltage Switching Device**

Pat. No. 2,884,587—granted Apr. 28, 1959 to H. F. Hanthorn and W. M. Stobbe.

## RADIO & "VICTROLA" DIVISION

Cherry Hill, N. J.

**Magnetic Record Transducer**

Pat. No. 2,885,488—granted May 5, 1959 to D. R. Andrews.

**Dial Indicator**

Pat. No. 2,886,992—granted May 12, 1959 to W. C. Roberts and H. Mendelson.

## RCA VICTOR TELEVISION DIVISION

Cherry Hill, N. J.

**Beam Deflection Control for Cathode Ray Devices**

Pat. No. 2,879,391—granted Mar. 17, 1959 to S. I. Tourshou.

**Noise Immune Automatic Gain Control Circuit**

Pat. No. 2,878,312—granted Mar. 17, 1959 to H. C. Goodrich.

**Electron Beam Convergence Apparatus**

Pat. No. 2,880,364—granted Mar. 31, 1959 to G. E. Kelly and M. Kolesnik.

**UHF-VHF RF Amplifier for Use in Tuners**

Pat. No. 2,880,282—granted Mar. 31, 1959 to D. J. Carlson.

**Phase Shifting Circuits for Color Television Receiver**

Pat. No. 2,881,245—granted Apr. 7, 1959 to A. F. Fenton and G. E. Kelly.

**Wide-Band Amplifier Circuits for Television Receivers and the Like**

Pat. No. 2,881,265—granted Apr. 7, 1959 to P. C. Swierczak.

**Deflection Systems**

Pat. No. 2,886,740—granted May 12, 1959 to M. B. Finkelstein.

## INDUSTRIAL ELECTRONIC PRODUCTS

Camden, N. J.

**Radiotelephone Switching Circuit with Receiver Squelch Control**

Pat. No. 2,868,964—granted Jan. 13, 1959 to H. F. Mohr.

**Composite Color Signal Transmission System**

Pat. No. 2,877,296—granted Mar. 10, 1959 to R. C. Dennison and A. C. Luther, Jr.

**Phase Generating Systems**

Pat. No. 2,879,441—granted Mar. 17, 1959 to A. C. Luther, Jr.

**Heat Radiator**

Pat. No. 2,879,041—granted Mar. 24, 1959 to R. T. Ross.

**Color Television Synchronizing Circuits**

Pat. No. 2,879,327—granted Mar. 24, 1959 to R. W. Sonnenfeldt.

**Ribbon Reversal Mechanism**

Pat. No. 2,884,111—granted Apr. 28, 1959 to E. A. Damerau.

**Coaxial Line Vacuum Tube Circuit**

Pat. No. 2,885,642—granted May 5, 1959 to L. L. Koros, R. N. Clark and M. W. Duris.

**Television Transmission System**

Pat. No. 2,887,575—granted May 19, 1959 to A. C. Luther, Jr.

**Reduction of Ghost Images in Television**

Pat. No. 2,888,515—granted May 26, 1959 to R. C. Abbett and K. Solomon, DEP, Camden, N. J.

## SEMICONDUCTOR AND MATERIALS DIVISION

Somerville, N. J.

**Silicon Junction Devices**

Pat. No. 2,878,432—granted Mar. 17, 1959 to L. D. Armstrong, H. D. Harmon and H. R. Meisel.

**Receiver Tuned by Inductors with Tracking by Initial Positionment of Coils on Cores**

Pat. No. 2,882,392—granted Apr. 14, 1959 to W. F. Sands.

**PEN** and

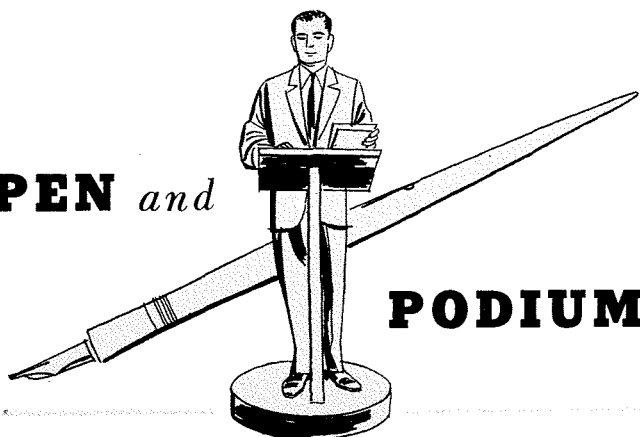

**PODIUM**

BASED ON REPORTS RECEIVED OVER A PERIOD OF ABOUT TWO MONTHS

## DEFENSE ELECTRONIC PRODUCTS

Moorestown, N. J.

### TR-1630 A Multiloop Transfluxor Memory

By D. G. Hammel, W. L. Morgan and R. D. Sidnam: Presented at the Western Joint Computer Conference, San Francisco, Calif., on Mar. 2, 1959. The non-destructive read characteristics and the separation of the read and write functions of the transfluxor are exploited to provide the basis of a new type of memory system.

### A Guidance Radar for Satellites, Space Vehicles and Ballistic Missiles

By E. A. Mechler, J. W. Porter and R. O. Yavne: Presented at the Naval Reserve Research Co., Willow Grove, Pa., Mar. 21, 1959. Ballistic missiles, satellites, and space vehicles for lunar navigation require a very precise measurement of velocity. Angular rates at 1,000,000 feet range must be measured. The design of a tracking radar and various instrumentation methods were discussed.

### The Evolution of Weapon Systems and a Concept for a Future Automatic Defense System

By H. W. Phillips: Presented at the Moorestown Lions Club, Moorestown, N. J., Apr. 8, 1959. The speaker, by means of slides and film, explained and illustrated the evaluation of electronic weapon systems, and set forth a concept for a national automatic defense system with human monitors.

### Operations Research in Air Defense Systems

By M. Hawley: Presented at the National Aeronautical Electronics Conference, Dayton, Ohio, May 4-6, 1959. Operations Research can be used very effectively in planning new weapons systems. The measure of system effectiveness is the quantitative description of the match between system performance and the operational environment, which includes the threat, the physical environment, and our own military posture.

### Reliability Considerations in Writing Incoming Inspection Instructions

By E. S. West: Presented at the Trenton, N. J. Technical Institute, Mar. 24, 1959. Incoming material quality control practices can be improved by inspecting for reliability characteristics selected at random.

### Bibliography of Digital Magnetic Circuits and Materials (Enlarged and Revised)

By W. L. Morgan: Published in the *IRE Transactions* of the IRE Prof. Group on Electronic Computers, June, 1959. A bibliography of digital magnetic circuits.

Camden, N. J.

### Thermistors—Properties and Uses

By B. R. Schwartz: Presented to the Philadelphia Chapter, Professional Group on Component Parts, IRE, at the Sheraton Hotel, Philadelphia, Pa., Mar. 19, 1959. Thermistors display radical change in their resistivity as a function of body temperature changes. The three characteristics (resistance-temperature, dissipation constant, and thermal-time constant) are available for a wide variety of control applications.

### Applying Military Reliability Research to Industrial Electronics

By H. L. Wuerffel: Presented at the Conference on Industrial Instrumentation and Control, Chicago, Ill., Apr. 15, 1959. Some of the achievements that have been accomplished in development of techniques to measure, predict and control reliability were enumerated.

### Automatic Communication System for Air Traffic Control

By R. E. Davis and D. T. Gross: Presented at the IRE Annual National Aeronautical Electronics Conf., Dayton, Ohio, May 4-6, 1959. AGACS Automatic Ground/Air/Ground Communication System (an experimental communication system being developed for the Federal Aviation Agency) Parameters were discussed, and explanations of the airborne equipment given.

### The Micro-Module Design Concept

By J. P. Gilmore: Presented at the National Aeronautical Electronics Conference, IRE, Dayton, Ohio, May 5, 1959. The Micro-Module Concept is based upon the construction of electronic components in wafer-like shape. These Micro-Wafers which assume the characteristics of basic electronic components; such as resistors and capacitors, were described as being combined to form oscillator and amplifier circuit modules.

### AN/ARC-62 Design Concepts to Meet Stringent Airborne Weapon System Requirements

By D. H. Westwood: Presented at the National Aeronautical Electronics Conference, IRE, Dayton, Ohio, May 6, 1959. This paper described the newly designed UHF Command Radio Set for the Air Force. Versatile design concepts make it applicable to many weapon systems for data as well as voice communications.

### Micro-Module Electronic Payloads

By H. J. Laming and J. W. Knoll: Published in the *Astronautics* Magazine, May 1959. This paper presents a description of the Micro-Module Concept and the present program status.

New York, N. Y.

**A New High Capacity Microwave Relay System**  
By C. G. Arnold, V. E. Isaac, RCA Victor Ltd., Montreal, and H. R. Mathwich, R. F. Privett, and L. E. Thompson, IEP, Camden, N. J.: Presented at the AIEE District 2 Conference Meeting in Baltimore, Maryland, May 19-21, 1959. The performance objectives, design, and test results of a new high-capacity microwave relay system were given.

## INDUSTRIAL ELECTRONIC PRODUCTS

Camden, N. J.

### Cryptanalysis

By E. L. Newman: Presented at Delaware Township High School, N. J., Mar. 4, 1959. A relationship of cryptanalysis to the communication art was cited followed by a brief history of cryptology. Then language statistics were discussed and applied to the analysis of a message enciphered by a simple substitution alphabet.

### The Transistor—A New Friend for the Broadcaster

By R. N. Hurst and J. W. Wentworth: Presented at the Convention of the National Association of Broadcasters, Chicago, Ill., Mar. 17, 1959. This paper is a friendly introduction to transistors for broadcasters whose prior experience has been solely with vacuum tubes. It explains basic principles.

### RCA 501 Electronic Data Processing System

By J. G. Smith: Presented at the Philadelphia Chapter IRE-AIEE/PGEC, Philadelphia, Pa., Apr. 9, 1959. In this talk, details of the logic implementation of such features as automatic address modification, accuracy control, on-line high speed printing and tape handling flexibility were described.

### On the Usefulness of Transconductance as a Transistor Parameter

By J. F. Cashen and A. Harel: Published in the correspondence section of the *Proceedings of the IRE*, May 1959 issue. Cut-off frequency of transistor transconductance is quantitatively discussed and is shown to considerably exceed that of beta, thus yielding a convenient parameter.

### Micro-Module Structural Design

By J. W. Knoll and H. S. Dordick: Presented at the Electronics Components Conference, Philadelphia, Pa., May 8, 1959. The Army RCA Micro-module is described and various integration methods illustrated. Five design goals are enumerated.

**A New High Capacity Microwave Relay System**  
By H. R. Mathwich, R. F. Privett and L. E. Thompson and C. G. Arnold, DEP, N. Y., and V. E. Isaac, RCA Victor Ltd., Montreal. Presented at the AIEE District 2 Conference Meeting in Baltimore, Maryland, May 19-21, 1959. The performance objectives, design, and test results of a new high capacity microwave relay were given.

## RCA RECORD DIVISION

Indianapolis, Ind.

### The Null Method of Azimuth Alignment in Multitrack Magnetic Tape Recording

By A. G. Evans: Presented at the 1959 IRE National Convention and also to be published in the *IRE Convention Record*. Several methods of head azimuth alignment in multitrack magnetic tape recording were discussed. The usual method of adjusting for maximum output from a high-frequency signal is not satisfactory, and a method for multitrack recording which makes use of the difference signal is suggested.

**The Effect of Flow Rate and Current Density on the Electrolytic Removal Rate of Iron and Copper from a Watts Nickel Solution**

By A. M. Max and M. L. Whitehurst: Presented at the Annual American Electroplaters Society Convention, Detroit, Michigan, June 22, 1959. Over a range of current densities, viz. 0.5 to 16 amp. per sq. ft. and flow rate, 6¼ to 50 ft. per min., the deposition of copper in a nickel solution is controlled by the diffusion rate of copper through the cathode film. The diffusion rate is increased materially with increasing flow.

**ELECTRON TUBE DIVISION**

Harrison, N. J.

**Electron-Tube Rating Systems and Ratings**

By R. N. Peterson: Presented at Student IRE Section, Newark College of Engineering, Newark, N. J., Mar. 30, 1959. This paper discussed the three rating systems now in use in the electron-tube industry, and reviews the physical considerations which determine ratings and applications.

**Practical Aspects of X-Ray Fluorescence Emission Spectrometry**

By E. P. Bertin and R. J. Longobucco: Presented at Seminar on X-Ray Diffraction and Spectroscopy, Camden, N. J., Apr. 20-22, 1959. This paper discusses the generation and nature of x-radiation, and its measurement by various electronic means.

**Professional Groups—and PG Chapters**

By E. M. McElwee: Published in IRE Northern New Jersey Newsletter, April 1959. This paper discusses the advantages of Professional Group Chapters to IRE members, and describes the procedure for starting a local Chapter of an established Group.

Lancaster, Pa.

**How Schools May Better Meet the Needs of the Science Age**

By W. N. Parker: Presented at Manheim Central High School Teachers Meeting, Manheim, Pa., Feb. 3, 1959. This paper discusses the advantages of a technical foundation for high-school education from both the civic and the business standpoints.

**Influence of Firing Conditions, Composition, and Screening Media on the Zeta Potentials of ZnS Phosphors as Related to Adherence to Glass Surfaces**

By B. Levy: Published in *Journal of the Electrochemical Society*, Mar. 1959. This paper describes the determination of zeta potentials of zinc-sulfide phosphors as functions of various manufacturing factors, and discusses the effect of these factors.

**Planning and Operating a Clean Shop**

By W. T. Dyal and L. C. Herman: Published in *ASTM Bulletin on Cleaning of Electron-Device Components and Devices STP-246*, Mar. 1959. This paper discusses considerations; in obtaining optimum cleanliness of manufacturing areas in an electron-tube factory; in tube design; and of convenience in developmental work.

**The Adsorption and Desorption Characteristics of Conductive Graphite Coatings**

By H. A. Stern, D. J. Donahue, and J. C. Turnbull: Published in *ASTM Bulletin on Cleaning of Electron-Device Components and Devices STP-246*, Mar. 1959. This paper describes a new measurement technique which makes it possible to define the adsorption, evolution, retention, and mechanisms of adsorption of carbon dioxide.

**Cathodic Electrocleaning of Molybdenum Wire Prior to Gold Plating**

By R. W. Etter: Published in *ASTM Bulletin on Cleaning of Electron-Device Components and Devices STP-246*, Mar. 1959. This paper describes the investigation of the gold-plating process used for electron-tube grids to determine the types of contaminants encountered on molybdenum wire, cleaning procedures, and the best surface for an adherent gold plating.

**Use of Radiotracers in Parts Cleaning Evaluation**

By M. N. Slater and D. J. Donahue: Published in *ASTM Bulletin on Cleaning of Electron-Device Components and Devices STP-246*, Mar. 1959. This paper describes the use of radiotracer techniques to explore the removal of a soluble inorganic salt by water and to investigate the effects of various rinsing and firing processes on the removal of acid etchant from cathode sleeves.

**An Image-Converter Tube for Viewing Ultraviolet Images**

By R. G. Stoudenheimer: Presented at Optical Society of America, New York City, Apr. 3, 1959. This paper describes the RCA ultrascopes, type 7404, an ultraviolet-sensitive image-converter tube for use in microscopy.

**An Improved Vidicon Focusing-Deflecting Unit**

By B. H. Vine and J. Castleberry: Published in *Journal of SMPTE*, Apr. 1959. This paper describes the design of focusing and deflecting coils to eliminate "beam landing error" or "porthole" in vidicons.

Princeton, N. J.

**Millimicrosecond Microwave Ferrite Modulator**

By A. H. Solomon and F. Sterzer: Published in *Proceedings of IRE*, Jan. 1959. This paper describes a high-speed microwave ferrite modulator which measures switching times of less than two millimicrosec.

**Electrostatically Focused Traveling-Wave Tube**

By D. J. Blattner and F. E. Vaccaro: Published in *Electronics*, Jan. 1959 and *Electronic Industries*, Jan. 1959. This paper describes a new traveling-wave tube which uses electrostatic rather than magnetic focusing, and provides small size, light weight, ruggedness, freedom from critical voltage adjustment, and no ion oscillation problem.

**Parametric Devices—Solid State Breaks the Microwave Barrier**

By W. R. Beam: Presented at AIEE Winter General Meeting, New York City, Feb. 3, 1959 and by W. R. Beam and F. Sterzer. This paper describes the parametric amplifier and similar devices whose operation depends on nonlinear circuit operation, and discusses the source and terminus of noise generated in each part of the devices.

**Fast Microwave Logic Circuits**

By D. J. Blattner and F. Sterzer: Presented at IRE National Convention, N. Y. City, Mar. 26, 1959. This paper describes basic logic elements, half-adders, and adders, using r-f pulse coding, and discusses their performance and limitations.

**Generation of Random Numbers at a High Rate Using Subharmonic Oscillators**

By F. Sterzer: Published in *Review of Scientific Instruments*, Apr. 1959. This paper describes a random number generator which uses two subharmonic oscillators and can produce random binary digits at a maximum rate of approx  $3 \times 10^7$  digits/per sec.

**Periodic Electrostatic Focusing of Laminar Parallel-Flow Electron Beams**

By W. W. Siekanowicz and F. E. Vaccaro: Published in *Proceedings of IRE*, Mar. 1959. This paper presents a model for laminar parallel flow that is valid for any amount of voltage variation and applies to axially symmetrical structure, and shows how to find the spatial potential distribution in the region of the electron beam.

**SEMICONDUCTOR & MATERIALS DIV.**

Needham, Mass.

**The Effect of Oxide Impurities on the Thermoelectric Powers and Electrical Resistivities of Bismuth, Antimony, Tellurium, and Bismuth-Tellurium Alloys**

By R. A. Horne: Published in *Journal of Applied Physics*, Mar. 1959. This paper discusses the sensitivity of bismuth, antimony, tellurium, and bismuth-tellurium alloys to the presence of oxide impurities and to the manner in which the thermal gradient is applied during measurement.

**Some Crystallographic and Magnetic Properties of Square-Loop Materials in Ferrite Systems Containing Copper**

By A. P. Greifer and W. J. Croft: Published in *Journal of Applied Physics*, Apr. 1959. This paper presents data on hysteresis loop squareness of polycrystalline bodies as a function of composition, firing conditions, and magnetostrictive effects for the system copper-ferrite—magnesium-ferrite.

Somerville, N. J.

**Advances in Semiconductors**

By W. M. Webster: Presented at IRE National Convention, N. Y. City, Mar. 24, 1959. This paper discusses recent advances in the field of semiconductor devices, including transistors, parametric amplifiers, thyristors, and micromodules, which show progress toward higher frequencies, higher powers, higher temperatures, and miniaturization.

**Forced Periodic Changes of Kinetic Energy of Gas Molecules as a Means of Vacuum Measurement**

By H. J. Schwarz: Presented at American Physical Society, Wash., D. C., Apr. 30, 1959. This paper describes a technique for measuring extremely low gas pressures which eliminates "background" noise and increases sensitivity.

**NATIONAL BROADCASTING CO.**

New York, N. Y.

**Fundamentals of Radio and Electronics (Second Edition)**

Edited by William L. Everitt and co-authored by Ray F. Guy, with Messrs. Pumphrey, Nelson, Ryder and Jordan. Text covers all the latest advances in radio and electronic science including material on transistors, color television, vacuum tube principles and circuits, application of radio to radar and navigation, Electronic Instrumentation, Broadcasting Transmitters and Receivers, and Industrial Electronics. Over 200,000 copies have been sold.

**RCA VICTOR LTD.**

Montreal

**A New High Capacity Microwave Relay System**

By V. E. Isaac, H. R. Mathwich, R. F. Privett and L. E. Thompson, IEP, Camden, N. J., and C. G. Arnold, DEP, N. Y. Presented at the AIEE District 2 Conference Meeting in Baltimore, Maryland, May 19-21, 1959. Objectives, design, and test results of a high-capacity relay system were discussed.

# RCA ENGINEER EDITORIAL REPRESENTATIVES

## DEFENSE ELECTRONIC PRODUCTS

F. D. WHITMORE, *Chairman, Editorial Board*

### Editorial Representatives

- DR. A. H. BENNER, *Airborne Systems Engineering, Camden, N. J.*  
JOHN BIEWENER, *Airborne Fire Control Engineering, Camden, N. J.*  
I. N. BROWN, *Missile and Surface Radar Engineering, Moorestown, N. J.*  
R. D. CRAWFORD, *Aviation Communications and Navigation Engineering, Camden, N. J.*  
R. W. JEVON, *Missile Electronics and Controls, Burlington, Mass.*  
J. H. PRATT, *West Coast Engineering, Los Angeles, Calif.*  
E. O. SELBY, *Surface Communications Engineering, Camden, N. J.*  
F. W. WHITTIER, *Development Engineering, Camden, N. J.*  
H. L. WUERFFEL, *Engineering Standards and Services, Camden, N. J.*

## INDUSTRIAL ELECTRONIC PRODUCTS

C. W. SALL, *Chairman, Editorial Board*

### Editorial Representatives

- N. C. COLBY, *Communications Engineering, Camden, N. J.*  
C. E. HITTLE, *Hollywood Engineering, Hollywood, Calif.*  
C. D. KENTNER, *Broadcast Transmitter and Antenna Engineering, Camden, N. J.*  
T. T. PATTERSON, *Electronic Data Processing Engineering, Camden, N. J.*  
D. S. RAU, *RCA Communications, Inc., New York, N. Y.*  
J. H. ROE, *Broadcast Studio Engineering, Camden, N. J.*  
J. E. VOLKMANN, *Industrial and Audio Products Engineering, Camden, N. J.*

## RCA LABORATORIES

### Editorial Representative

E. T. DICKEY, *Research, Princeton, N. J.*

## RCA SERVICE COMPANY

### Editorial Representatives

- W. H. BOHLKE, *Consumer Products Service Department, Cherry Hill, N. J.*  
M. W. TILDEN, *Government Service Department, Cherry Hill, N. J.*  
E. STANKO, *Technical Products Service Department, Cherry Hill, N. J.*

The Editorial Representative in your group is the one you should contact in scheduling technical papers and arranging for the announcement of your professional activities. He will be glad to tell you how you can participate.

## RCA ELECTRON TUBE AND SEMICONDUCTOR & MATERIALS DIVISIONS

J. F. HIRLINGER, *Chairman, Editorial Board*

### Editorial Representatives, RCA Electron Tube Division

- W. G. FAHNESTOCK, *Conversion Tube Operations, Lancaster, Pa.*  
J. DEGRAAD, *Black & White Kinescopes, Marion, Ind.*  
D. G. GARVIN, *Entertainment Tube Products, Lancaster, Pa.*  
A. E. HOGGETT, *Receiving Tubes, Cincinnati, Ohio*  
R. L. KLEM, *Entertainment Tube Products, Harrison, N. J.*  
J. KOFF, *Receiving Tubes, Woodbridge, N. J.*  
H. S. LOVATT, *Power Tube Operations, Lancaster, Pa.*  
F. H. RICKS, *Receiving Tubes, Indianapolis, Ind.*  
H. J. WOLKSTEIN, *Industrial Tube Products, Harrison, N. J.*

### Editorial Representatives, RCA Semiconductor & Materials Division

- T. A. RICHARD, *Needham, Mass.*  
RHYS SAMUEL, *Micromodules, Somerville, N. J.*  
HOBART TIPTON, *Semiconductor Devices, Somerville, N. J.*

## RCA VICTOR TELEVISION DIVISION

C. M. SINNETT, *Chairman, Editorial Board*

### Editorial Representatives

- D. J. CARLSON, *Advanced Development Engineering, Cherry Hill, N. J.*  
E. J. EVANS, *Resident Engineering, Bloomington, Ind.*  
R. D. FLOOD, *Color TV Engineering, Cherry Hill, N. J.*  
F. T. KAY, *Black & White TV Engineering, Cherry Hill, N. J.*  
J. OSMAN, *Resident Engineering, Indianapolis, Ind.*  
H. P. J. WARD, *Electronic Components, Findlay, Ohio*  
K. G. WEABER, *Engineering Services, Cherry Hill, N. J.*

## RCA VICTOR RECORD DIVISION

### Editorial Representative

S. D. RANSBURG, *Record Engineering, Indianapolis, Ind.*

## RCA VICTOR RADIO & "VICTROLA" DIVISION

### Editorial Representative

W. S. SKIDMORE, *Engineering Department, Cherry Hill, N. J.*

## ASTRO-ELECTRONIC PRODUCTS DIVISION

### Editorial Representative

E. A. GOLDBERG, *Engineering, Hightstown, N. J.*



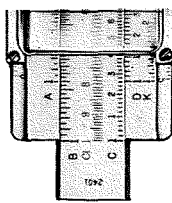

## TWO CHIEF ENGINEERS NAMED

### EARL ANDERSON NAMED CHIEF ENGINEER OF RCA VICTOR HOME INSTRUMENTS

Earl I. Anderson has recently been appointed to the newly-created position of Chief Engineer, Home Instruments Engineering.

Formerly Chief Engineer, Communications Engineering, IEP, he will be responsible in his new position for all advanced development and product engineering associated with TV and Radio "Victrola" products.

Mr. Anderson joined RCA as an engineer in the Industry Service Laboratory in New York in July, 1937. He advanced through various positions and was appointed Engineer-in-Charge in 1954. He was named Chief Engineer of the Communications Products Department, Camden, in March 1958. His work at the Industry Service Laboratory kept him in close association with the rapidly advancing television receiver field. Mr. Anderson was given a Fellow Award by the IRE in 1954 for his contributions in this area. He also holds some 30 patents.



### GEORGE BREITWIESER BECOMES CHIEF ENGINEER OF NEW WEST COAST DEPARTMENT

George F. Breitwieser has been appointed Chief Engineer, West Coast Missile and Surface Radar Department, reporting to A. N. Curtiss, Manager of that Department. His appointment as head of RCA's Atlas Missile Check-out and Launch Control program, with which he has been closely associated, coincides with the transfer of this work from Moorestown to the West Coast.

Mr. Breitwieser will have charge of all West Coast Engineering activities for RCA-DEP. He was formerly Chief Engineer of the Missile and Surface Radar Department in Moorestown. Since joining RCA in 1949 he has made substantial contributions to a number of major defense products. He was awarded the RCA Victor Award of Merit in 1956.



## RCA ENGINEER WINS TOP NEW JERSEY AWARD

*This choice news item was received too late to include in the Dec./Jan. 1959 issue, so your Editorial Staff decided to reserve it for this issue which celebrates the publication's fourth anniversary.*

Selected from a state-wide field of publications representing more than fifty New Jersey industries, the RCA ENGINEER received the top prize of three 1958 New Jersey editorial awards. The New Jersey Industrial Editor's Association presented the awards at a dinner session at Military Park Hotel, Newark, New Jersey during the As-

sociation's fourteenth annual meeting. Other award recipients were the *Natural Gaser*, representing the New Jersey Natural Gas Co. and the *Ciba Sidelights* representing the Ciba Pharmaceutical Products.

In making the presentations, Calvin Lauderback, Editor of the *New Jersey Business* magazine stated that, "competition was judged solely from the standpoint of excellence in interpreting editorial policy in company publications." Awards were received by D. F. Schmit on behalf of the Radio Corporation of America and by W. O. Hadlock, Editor of the RCA ENGINEER.

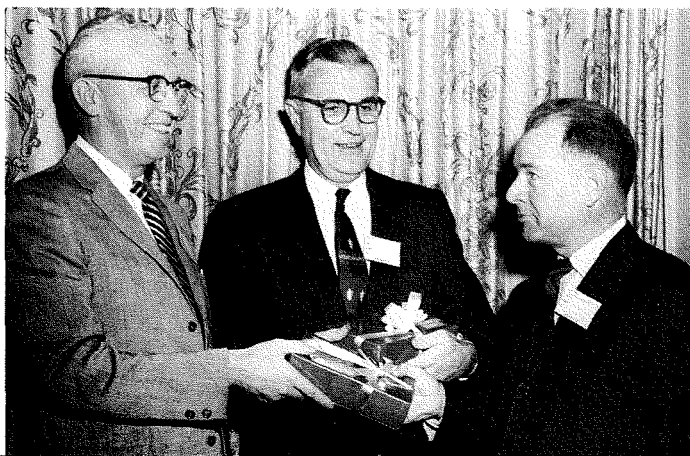

## ENGINEERS IN NEW POSTS

In the Tube Division, F. E. Vaccaro becomes Mgr. Microwave Advanced Dev. under H. K. Jenny . . . A. G. Petrusek is appointed Mgr. Advanced Market Planning, with H. F. Kazanowski reporting to him for Adv. Planning in Industrial Markets . . . W. Widmaier is Mgr. Production Eng. for Photo and Image Tube Mfg. . . . R. W. Young becomes Mgr. Parts Prep. Production Eng. under H. R. Snow at Woodbridge. . . .

G. C. Brewster, Mgr. Data Systems and Service at Harrison announces his staff as follows: J. R. Gates, Mgr. Technical Systems Planning; W. K. Halstead, Mgr. Electronic Business Systems Planning; A. J. Moffitt, Admin., Data Processing Coordination, and Brewster acting as Mgr. Data Processing Operations.

In AEP Princeton, W. H. Brearley becomes Eng. Admin. Mgr. for Ch. Eng. S. Sternberg.

At Somerville, Dr. R. B. Green is appointed Materials Planning Mgr., Marketing, for Semicond. and Mat'ls. Div. . . . E. O. Johnson becomes Mgr., High Temp. Product Devel. at Somerville, coming from Princeton Labs.

Bruce Rechel, Manager of RCA International's Office in Camden for the past five years, is now in Tokyo as Manager of the RCA Laboratory in Japan. Al Gordon is replacing him as Manager of the Camden Office.

## NEW EDITORIAL REPRESENTATIVE APPOINTED

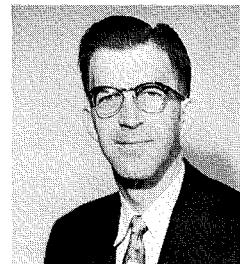

Richard D. Crawford replaces Charles McMorrow as Editorial Representative for Aviation Communications and Navigation Engineering, Airborne Systems Department, DEP. The Editors would like to thank Mr. McMorrow for his active participation in RCA ENGINEER affairs since its inaugural issue in June, 1955.

Richard D. Crawford was graduated from the University of Illinois in 1945 with a BS degree in E.E. and came to RCA in the same year. He worked for three years in Aviation Engineering as an engineer in the pulse radar altimeter group where he worked on timing circuits, IF and video amplifier circuits, CRT and direct reading servo indicators.

In 1948 he was employed by Wickes Engineering and Construction Company at Camden, New Jersey. In 1952 he was promoted to Chief Engineer of the company where he served until the end of 1956.

In January 1957, he returned to RCA to his present position as Administrator, Technical Coordination, in Airborne Communications Engineering, Airborne Systems Department.

Receiving awards are (left) W. O. Hadlock and D. F. Schmit from Calvin Lauderback (right).

## RAY GUY DOUBLY HONORED



Raymond F. Guy of NBC New York was recently honored by being elected to the grade of Fellow of the American Institute of Electrical Engineers, and in receiving a Citation from the Broadcast Pioneers.

Raymond F. Guy, Senior Staff Engineer of the National Broadcasting Company, was on the original staff, composed of only a few persons, at WJZ when it was opened by the Westinghouse Company in Newark, in 1921 as the world's second broadcasting station.

Before the beginning of broadcasting, Mr. Guy was employed at intervals by the Marconi Wireless Telegraph Co., the Ship-owners Radio Service and the Independent Wireless Telegraph Co. During the concluding engagements of WW I, he served in France in the Regular Army, and entered Pratt Institute upon discharge, graduating in Electrical Engineering in 1921. In 1924 he joined the engineering staff of the RCA Research Laboratories, and for 25 years of his career he directed the planning and construction, for all services, of all NBC transmitting facilities, including frequency allocations and other allied activities.

Mr. Guy was President of the Institute of Radio Engineers in 1950 after many years as Officer and Director. He is a member of the Broadcast Advisory Committee of the Voice of America, and was for many years Chairman of the Engineering Advisory Committee of the National Association of Broadcasters.

He is a Fellow of the Radio Club of America, and the IRE, a charter member of the Twenty Year Club and the Broadcast Pioneers, a life member and First Vice President of the Veteran Wireless Operators Association, and a member of the Society of Professional Engineers, and of many other professional societies.

### HAWLEY ELECTED ASA FELLOW

M. E. Hawley, Manager of Operational Planning, Missile and Surface Radar Dep't, DEP Moorestown, has been elected Fellow of the Acoustical Society of America early this year (see his article this issue on operations research).

### DR. HEROLD WINS AWARD

Dr. Paul G. Herold of the Chemical & Physical Laboratory at Lancaster received an award of \$50 as the winner of the April contest for the best paper contributed to the Product Design Notebook Section of CHEMICAL ENGINEERING for April. The article was entitled "Surplus Searchlight Makes Solar Furnace," and is the furnace described by Dr. Herold in the February-March issue of the RCA ENGINEER. —D. G. Garvin

## MEETINGS, COURSES, AND SEMINARS

### 501 Training

The RCA Service Company's Technical Products Engineering began its first series of training courses on the new transistorized 501 Data Processing System in March. Graduates of these classes will become the future maintenance personnel at the many installations scheduled for 1959-60. The training schedule has been arranged by John J. Lawler and will be conducted at the Pennsauken (N. J.) Training Laboratories under the direction of George Kropp, Training Supervisor. Instructors are J. Anderson, R. Heacock, and H. Morgensen.

—E. Stanko

### NAB Convention

The annual convention of the National Association of Broadcasters was held in Chicago during March, 1959. RCA personnel and products were prominent at the convention, with many new RCA products being introduced. Among these were highly versatile special effects equipment for TV program assembly. R. C. Dennison of TV Broadcast equipment Engineering, IEP, was primarily responsible for the design. There was also a highly successful demonstration of RCA's new video tape recording equipment highlighting RCA's display, which attracted large crowds throughout the exhibit session. The equipment was the first production unit, scheduled for Station WBTV, Charlotte, S. C. A new portable master monitor (the TM35) with self-contained power supply was a further attraction in RCA's exhibit. It will find wide application in both closed circuit and broadcast television systems.

A TV Technical Training Seminar followed the NAB Convention, and was attended by about 160 engineers and management people from broadcast stations and closed circuit operations. The lectures were delivered by engineers in the Broadcast and Television Engineering Department of IEP.

—J. H. Roe

### Fundamental Radio Course

Leo Whitcomb, an engineer in Marion Equipment Development, Tube Division, has been chosen to teach a Fundamental Radio Course provided by the RCA Institute being offered to those interested engineers whose professional work is in such fields as chemistry, mechanical engineering, etc. The Course is being given once weekly out-of-hours.

Mr. Whitcomb also is presently teaching a basic electronics course to a selective group having no technical background. He will follow the basic course with a five-session course in transistors and their applications. —J. De Graad

### RCA HOST TO SES AWARDS COMMITTEE

Awards Committee of the Standards Engineers Society met at the RCA main office building conference room on Tuesday, May 12, 1959, to discuss the awards to be presented to outstanding men in the standards field at the Society's Annual Meeting in Boston on September 21-22, 1959.

The awards under consideration are the Fellowship and the SES-ASTM awards for meritorious service and outstanding publication in the field of Standardization.

### Science Fair Exhibit

F. J. Hinnenkamp and J. S. Martin, Engineers in the Chemical and Physical Lab Color Kinescope Engineering at Lancaster were among the judges reviewing the Science Fair Exhibit presented by 450 students of the Bishop McDevitt High School, Harrisburg, Pa. —D. G. Garvin

### TV Seminar

The annual Washington-Seminar on Broadcast Television was held May 12 and 13, 1959, and was attended by about 150 consultants and government representatives. Talks delivered by RCA engineers were:

A. H. Bott—New FM Multiplex and Transmitter Equipment

H. H. Westcott—Traveling Wave Antenna  
J. B. Bullock—TVM-1A Microwave Equipment, Technical Details for Planning

L. M. Seeberger—Slow Scan TV

—J. H. Roe

### Standards

F. M. Oberlander, Administrator, Materials Standards, Product Engineering Standardizing, addressed the Lancaster Plant engineers on April 30 on "Some Aspects of Standardization in RCA." The meeting was part of the Lancaster Engineering Education Program.

### 20 HIGH SCHOOL STUDENTS TAKE ENGINEERING COURSE

Twenty Moorestown (N. J.) High School Students have completed the "Engineering Orientation and Basic Electronics Course" conducted at the Moorestown Engineering Plant for the third year. The program is conducted by RCA Moorestown in cooperation with Moorestown High School officials. The purpose of the program is to encourage the scientific and technical interests of the students and to acquaint them with career possibilities in electronics engineering.

The students were chosen on the basis of scholastic ability in science, physics and math and their interest in these areas. The group meeting was for nine lecture sessions of 1½ hours each, and four laboratory sessions of four hours each.

The laboratory project for the course was the building of a 5-tube radio which each student was allowed to keep. The lectures were given by Herbert Clarke, Leader in radar and electronics, assisted by R. L. Hill, technician.

At "graduation" ceremonies, the students and their parents were addressed by General Manager H. R. Wege and T. G. Greene. Mr. Greene, engineering project leader, taught the school in its first two years.

The national SES Committee making the selection is headed by Prof. Leo B. Moore, Associate Professor of Industrial Management, Massachusetts Institute of Technology. Other members of the Committee are Madhu S. Gokhale, DEP Central Services and Engineering; Vice Adm. George F. Hussey, Jr., Executive Secretary, American Standards Association and Fred M. Oberlander, RCA Product Engineering.

**TEN RCA EMPLOYEES AWARDED  
DAVID SARNOFF FELLOWSHIPS**

David Sarnoff Fellowships for graduate study in the 1959-60 academic year have been awarded to ten employees of RCA, Dr. Irving Wolff, Vice President, Research, and Chairman of the RCA Education Committee, announced recently.

"The Fellowships, established in honor of the Chairman of the Board of RCA, are valued at approximately \$3,500 each," Dr. Wolff said. "The grant includes full tuition and fees, \$2,100 for living expenses, and \$750 as an unrestricted gift to the university.

"Although appointments are for one academic year, each Fellow is eligible for re-appointment. Five of the ten recipients named this year are receiving the awards for the second consecutive year."

The David Sarnoff Fellows were selected on the basis of academic aptitude, promise of professional achievement, and character. They will pursue graduate studies in chemistry, physics, engineering science, electrical engineering, physical chemistry, economics, business administration, and dramatic arts.

The five David Sarnoff Fellows reapointed for a second year include:

Raymond J. Campion, who is studying for a Doctorate in Chemistry at Washington University. He is on leave of absence from the Electron Tube Division and Harrison.

Robert A. Schmeltzer, studying for a Doctorate in Engineering Science at New York University. He is on leave from the Semiconductor and Materials Division at Somerville.

Edward L. Balinsky, studying toward a Doctorate in Economics at Columbia University. He is on leave from NBC.

Paul Potashner, studying toward a Master of Science degree in Business Administration at Harvard. He is on leave from the International Division at Clark, N. J.

Earl R. Sage, studying toward a Master of Science in Business Administration at Harvard. Mr. Sage is on leave from the Semiconductor and Materials Division at Findlay, Ohio.

The five employees awarded David Sarnoff Fellowships for the first time include:

Ivan Bernal, who will study toward a Doctorate in Physical Chemistry at Princeton University. He will be on leave from RCA Laboratories at Princeton.

Sanford M. Marcus, who will begin studies toward a Doctorate in Physics at the University of Pennsylvania. He is on leave from DEP, Camden.

Charles W. Rector, who will begin studies toward a Doctorate in Physics at Johns Hopkins, on leave from the Electron Tube Division at Lancaster.

John J. Sie, will begin studies toward a Doctorate in Electrical Engineering at the Polytechnic Institute of Brooklyn, on leave from DEP in New York City.

Lew R. Hunter will begin studies toward a Master of Arts degree in Film Production at the University of California at Los Angeles. He will be on leave from NBC in Burbank, Cal.

**DR. SHAW AT RUTGERS INAUGURATION**

Dr. G. R. Shaw, Chief Engineer, Electron Tube Division represented the University of Wisconsin at the installation of Dr. Mason W. Gross as President of Rutgers University, New Brunswick, N. J. on May 6, 1959.

**COMMITTEE  
APPOINTMENTS**

**Lowell H. Good**, Director, Engineering Utilization, RCA Product Engineering, has been elected Vice-Chairman of the Philadelphia Chapter of the IRE.

**G. G. Thomas**, Tube Division at Lancaster, has been appointed Chairman of the Engineering Education Committee succeeding Dr. L. B. Headrick who has transferred to C Stellerator Associates, Princeton.

—D. G. Garvin

**Dr. R. T. Watson** of the Black and White Kinescope Engineering Advanced Development Group at Marion has been designated Chairman of the Marion Engineering Education Committee. The Committee Vice Chairman is **Mr. Jack Stewart** of Equipment Development. Other members of the Committee are **J. C. Dobie** of Tube Parts Manufacturing Engineering; **C. W. Thierfelder** and **C. T. Lattimer** of Black and White Kinescope Engineering; **A. N. Brooks** of Plant Quality Control; **L. M. Wiley** of Manufacturing Standards; **L. F. Hopen** of Tube Manufacturing Engineering; and **G. M. Rhetts**, Training Administrator.

—Jan De Graad

**Paul D. Strubhar** of the Lancaster Chemical and Physical Laboratory was elected Chairman of the York, Pennsylvania, chapter of the American Society for Metals on April 8, 1959.

—D. G. Garvin

**Mr. Donald G. Garvin**, Editorial Representative, Color Kinescopes at Lancaster, was elected First Vice President of the University Club of Lancaster for the 1959-1960 session.

—J. F. Hirlinger

**A HAIR IS NO LONGER THIN**

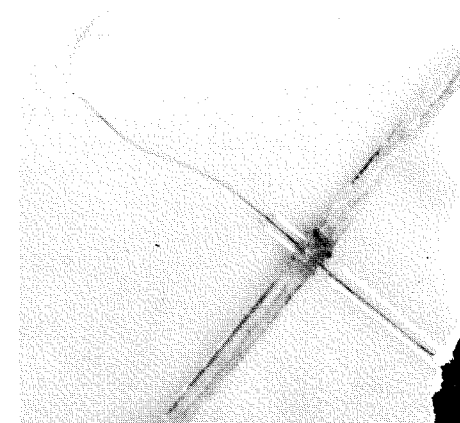

Lester C. Herman, of the Conversion Tube Development Shop, Tube Division, Lancaster, submitted the accompanying photograph with the following explanation of it: the largest diameter object shown is a human hair, 0.002 inches in diameter. A hole, 0.001 inches in diameter was drilled through the hair and a glass tube pushed through the hole. A tungsten wire, 0.00015 inches thick was then threaded through the glass tube.

Mr. Herman attached some rather detailed information on the photographic processes involved in getting the picture, but volunteered no comment on the mental state of the assembler.

**FAHNESTOCK APPOINTS ASSISTANTS**

Conversion Tube Operations of the Industrial Tube Products Dept. at Lancaster announces the appointment of G. D. Cartwright, E. A. Dymacek, R. R. Handel, R. P. Stone, J. L. Weaver, and W. Widmaier as Assistant Editorial Representatives for their respective areas.

<i>Representative</i>	<i>Representation</i>
G. D. Cartwright .....	Storage & Oscillograph Production Engineering
E. A. Dymacek .....	Camera Tube Production Engineering
R. R. Handel .....	Conversion Tube Shop Engineering
R. P. Stone .....	Camera, Oscillograph & Storage Tube Engineering
J. L. Weaver .....	Photo & Image Tube Engineering
W. Widmaier .....	Photo & Image Tube Production Engineering

—W. G. Fahnestock

**CLIP OUT AND MAIL TO:**

**EDITOR, RCA ENGINEER**  
Radio Corporation of America  
Bldg. 2-8, Camden 2, N. J.

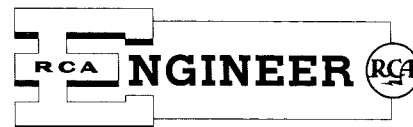

**HAVE WE YOUR CORRECT ADDRESS?**

If not indicate the change below.

**PLEASE INDICATE THE CODE LETTER(S) THAT  
APPEAR NEXT TO YOUR NAME ON THE ENVELOPE.**

Name \_\_\_\_\_ Code \_\_\_\_\_

Street or Bldg \_\_\_\_\_

City and State or Plant \_\_\_\_\_