

BROADCAST NEWS

Type 96-A
Limiting Amplifier
Page 14.



In This Issue



Lightning is a Menace . . . By J. E. Young
Improved Service for CBS Foreign Listeners
The Human Side of Marconi



RCA MANUFACTURING COMPANY, INC., CAMDEN, N. J.



RCA Manufacturing Company, Inc.

A Service of Radio Corporation of America

Camden, N. J.

"RADIO HEADQUARTERS"

DAVID SARNOFF, Chairman of the Board

G. K. THROCKMORTON, President

L. B. MORRIS, Vice-President
and General Counsel

J. M. SMITH, Vice-President in
Charge of Mfg., RCA Radiotron Div.

R. SHANNON, Vice-President in
Charge of Mfg., RCA Victor Div.

J. C. WARNER, Vice-President and
General Mgr., RCA Radiotron Div.

LEWIS M. CLEMENT, Vice-President
in Charge of Research and
Engineering, RCA Victor Div.

J. T. CLEMENT, Vice-President
in Charge of Washington
D. C., Office

F. H. CORREGAN, Vice-President
and Secretary

F. R. DEAKINS, Manager Special Products

J. L. SCHWANK, Manager

ENGINEERING PRODUCTS DIVISION

AND INTERNATIONAL DIVISION

TRANSMITTER SALES SECTION

(OF ENGINEERING PRODUCTS DIVISION)

I. R. BAKER, Manager

C. L. BEACH, Affiliated Company Contact

C. M. LEWIS, Speech Input Equipment

T. A. SMITH, Broadcast Transmitters

H. C. VANCE, Communications Equip-
ment, State Police

J. C. CALVERT, Sales Engineer

T. W. ENIS, Affiliated Companies

S. W. GOULDEN, Commercial Engineer

F. S. HART, Sales Contact

J. P. TAYLOR, Sales Engineer

1 **EASTERN DISTRICT**—Ben Adler, Manager and CBS Contact, 1270 Sixth Ave., New York City; R. P. May, Asst.

MAINE
NEW HAMPSHIRE
VERMONT
MASSACHUSETTS

RHODE ISLAND
CONNECTICUT
NEW YORK
NEW JERSEY

VIRGINIA
DELAWARE
MARYLAND
PENNSYLVANIA

WEST VIRGINIA
NORTH CAROLINA
(Broadcast)

2 **CENTRAL DISTRICT**—A. R. Hopkins, Manager, 589 E. Illinois Street, Chicago, Illinois; R. A. Wilson, Assistant; A. Josephsen, Assistant.

NORTH DAKOTA
SOUTH DAKOTA
MINNESOTA

NEBRASKA
WISCONSIN
ILLINOIS

MISSOURI
IOWA
KENTUCKY

OHIO
MICHIGAN
INDIANA
KANSAS CITY (KANSAS)

3 **WESTERN DISTRICT**—W. H. Beltz, Manager, 1016 N. Sycamore Street, Hollywood, California; Edmund Frost, Assistant, 170 Ninth Street, San Francisco, California.

WASHINGTON
OREGON

IDAHO
NEVADA
CALIFORNIA

UTAH
ARIZONA
HAWAII (Police)

MONTANA
WYOMING
ALASKA (Police)

4 **SOUTHWESTERN DISTRICT**—W. M. Witty, Manager, 2211 Commerce St., Dallas, Texas

TEXAS
OKLAHOMA

ARKANSAS
COLORADO

NEW MEXICO

KANSAS (Except Kansas City)
LOUISIANA (Except New Orleans)

5 **SOUTHEASTERN DISTRICT**—D. A. Reesor, Manager, 490 Peachtree St., N. E., Atlanta, Ga.

TENNESSEE
MISSISSIPPI

GEORGIA
FLORIDA

ALABAMA
NEW ORLEANS (LA.)

NORTH CAROLINA (Police)
SOUTH CAROLINA

POWER RADIOTRONS
POLICE TRANSMITTERS

POLICE RECEIVERS
SPECIAL COMMUNICATION EQUIPMENT

BROADCAST TRANSMITTERS
AVIATION RADIO EQUIPMENT

BROADCAST NEWS

REG. U. S. PAT. OFF.

PAUL V. LUTZ, Editor

BOARD OF ADVISORY EDITORS

J. B. Coleman.....	Transmitters	M. C. Batsel... Test Apparatus and Studio Equipt.
V. E. Trouant.....	Transmitter Development	F. X. Rettenmeyer..... Receivers
E. W. Engstrom.....	Television	Dr. Irving Wolff..... Microwaves
Dr. V. K. Zworykin.....	Electronic Research	Dr. H. F. Olson..... Acoustics

NUMBER 26

NOVEMBER, 1937

TABLE OF CONTENTS

Cover Design John Vassos

(See Page 33)

	Page
The Human Side of Marconi	2
Improved Service for CBS Foreign Listeners	4
Streamlined Convenience	7
By John Vassos	
Going Places in Dixie	8
By J. L. Talley	
Press Mistakes About Marconi	9
By G. H. Clark	
Space Becomes a Factor	10
By C. M. Lewis	
Lightning Is a Menace	12
By J. E. Young	
A New Limiting Amplifier	14
By B. W. Robins and J. M. Brumbaugh	
Further Notes on External Cross Modulation	16
By Dudley E. Foster	
Buffalo Station Increases Power	18
By Karl B. Hoffman	
Directional Antennas	20
By Dr. G. H. Brown	
Wider Coverage for WFBM	22
By M. R. Williams	
Columbia's Television Transmitter Nears Completion.....	30
A Review of Broadcast Engineering	34
By J. P. Taylor	

Published in the Interest of the Radio Broadcasting Industry
and Copyrighted, 1937, by the

RCA MANUFACTURING COMPANY, INC.

CAMDEN, NEW JERSEY, U. S. A.

THE HUMAN SIDE OF MARCONI

Incidents that Reveal An Interesting Personality

WE have all read much of Marchese Guglielmo Marconi, Senatore of Italy, President of the Royal Academy of Italy and of the Italian National Council of Research—intimate friend of rulers, church dignitaries, executives and engineers in all countries. Only a few, however have been privileged to know the intensely human Marconi and of his association with his fellowmen and fellow workers. We are fortunate in being able to recount here some pertinent anecdotes from his more personal life.

* * *

Wireless was first introduced to this country by Mr. Marconi, who came here with a set of instruments in 1899 to report the International Yacht Races. His eagerness to get his apparatus set up was balked by formalities of the Customs Office, and after Marconi had climbed up and down the steep steps of the Customs House a half dozen times, he said with a weary smile, "When does the next boat leave for Liverpool? This is too much of a rush for me." But eventually he got his trunks released, and the races were reported with great success.

Marconi was his own operator, though a poor one, and while sending a message with the letter 'J' he had to look up the telegraphic characters on a card. "Why wasn't he named Robert," he said with a chuckle, "instead of John?" After the races a group of reporters and yachtsmen met on the transmitting yacht PONCE, and spent an hour or two with Signore Marconi, where he sat at the piano and played for an hour, running the range between popular songs and light opera, voted by all as "a prince of a good fellow."

A Hard Worker

Marconi was a hard worker, and required long hours and patient attention to duty from his subordinates. But he so fired them with zeal reflected from his own tireless efforts that they were an especially loyal group. In 1912, a group of American Marconi en-

Editor's Note: The personal reminiscences which make up this article have been contributed by those who were associated with Marconi at various periods during his life. All found in him an intensely interesting personality quite apart from the character they knew as the discoverer of radio.

Among those contributing are: John Cowden, one of the oldest wireless men in the U. S. A.; Harold Beverage, Chief Research Engineer, RCAC, and president of I. R. E.; Paul Godley; G. H. Clark, former president VWOA; H. E. Hallborg, RCAC.

gineers was sent to England to study the huge Marconi transmitters there, preparatory to installing duplicates in our American high-power stations. Day after day Mr. Marconi would come to the station with mysterious packages

under his arm—sometimes a new form of spark gap, or a jigger for receiving, which would then be tried out in practice. One cold, rainy night, Mr. Marconi came in quite unexpectedly, having walked several miles from the railway station, but carrying the usual package. Everyone eagerly watched while he unwrapped—not a condenser nor a new magnetic detector, but a dozen phonograph records. "I thought you young men from the States might be rather lonely out here," said Mr. Marconi, "So I have brought you some gramophone records." So saying, he placed the first record on the machine, and the



The Genius of Radio aboard his yacht "Elettra."

homesick Americans heard the strains of "Everybody's Doing It Now."

Mr. Marconi was scrupulously truthful, and that meant that everything had to be checked for accuracy. This is well shown by an incident in his reception of the first signals across the Atlantic, in 1901. Marconi and his assistant were in the cold stone room provided for them in a Newfoundland barracks, and Marconi was tuning again and again for the signal he desired. Nothing but crashes and clicks of static were heard, until suddenly Marconi heard three faint buzzes, with the low-pitch rhythm that identified the signals with distant Poldhu. Again and again he heard them, but giving no sign to his assistant, he handed over the headphones and said, "Mr. Kemp, do you hear anything?" Even when Kemp checked his observations, Marconi would give out no statement as to his success until both he and Kemp had again received signals the following day.

Wary of Reporters

Marconi was always willing to give reporters the news of an invention or a new record of transmission, but prophecies and the like were his greatest antipathy. One day he made the serious mistake of using obvious sarcasm. "Gentlemen" said he to reporters, "You seem to want me to tell you something new, so I will. I have been talking with Mars, but don't tell anyone about it." To his surprise, his words were taken in dead earnest, and the newspapers of the world blazoned forth the story of "Marconi talking with the stars." That experience taught him not to joke — with reporters. "It's strange," he said, "if I describe an actual invention I may get a little space in the papers, although the foreign ones will be sure to say their countrymen thought of it first, —but if I hand them a package, every newspaper in the world will devote column after column to it."

One of the most famed rescues at sea where radio played a part was the Steamship Titanic, in 1912. Marconi was at that time in New York, and when the survivors finally reached that city, they gathered under the balcony of the apartment where Marconi lived and shouted in chorus, "We owe our lives to you." Then a special

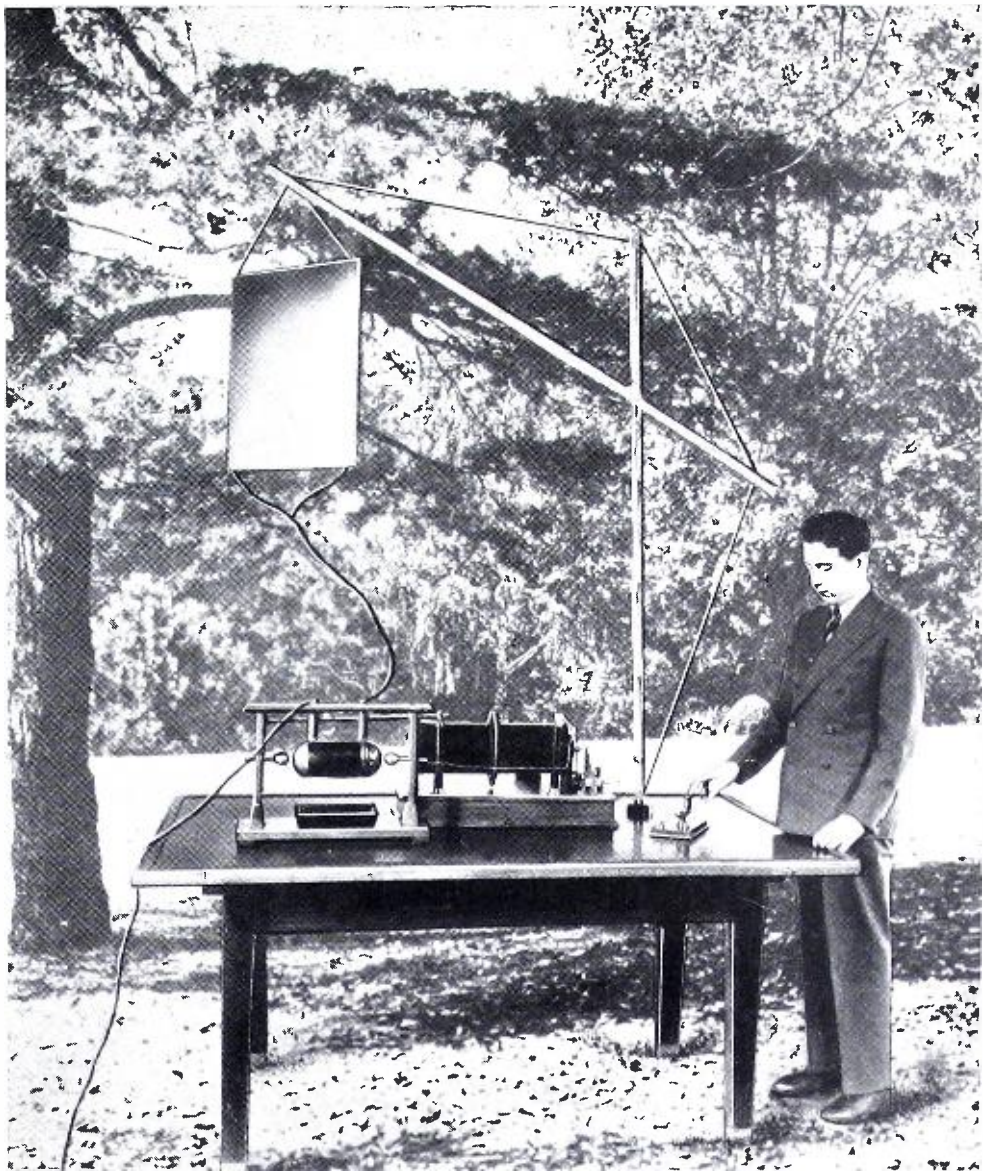

Forty-two years after Marconi's historic experiment with wireless on his father's estate at Bologna, his son, Gulio, repeats the operation, using a "replica" of the original equipment.

delegation presented Marconi with a gold medal. An American young lady, whose father was among the rescued, tried to throw her arms around Marconi to kiss him. He, to hide his emotion, turned to the medal. "I will always treasure this medal," he said, "First because it means so much to me, and second, because it makes me appear good-looking."

Sense of Humor

Marconi's quiet humor extended to every one of his intimates, even to the highest dignitaries. One evening he was entertaining a high official of the church and was receiving broadcast entertainment from a frame aerial hidden in the chandelier. The prelate could see no antenna coming into the room, and asked if the electric signals came in through the window. "No, for you see it is closed," said Marconi. "Then how do they get in?" insisted his Eminence. "You can

answer better than I can," said Marconi, "for you are in more intimate relationship with things of divine origin."

Throughout all the adulation that was heaped upon Senatore Marconi, the honors he received, the incredibly swift growth of the new art of which he was the father, he never got out of touch with those later youthful enthusiasts in the field of radio. In 1925 the American Radio Relay League sent a representative to Scotland in an attempt to receive signals from American amateurs. They were successful, for a number of United States stations were logged. The wireless Society of England gave a dinner in London in honor of the achievement, which Mr. Marconi attended. On that occasion he said of amateurs: "I am never so happy as when I am talking with the young men of today who are so eagerly working on wireless communication

(Continued on Page 31)

IMPROVED SERVICE FOR CBS FOREIGN LISTENERS

New Facilities Provide Entertainment for Many Lands

A LONDON bus-driver, a tea salesman in Sidney, a bridge engineer in Brazil, and a retired army captain in New Zealand—these are some of the thousands of short-wave listeners all over the world who have written in to the Columbia Broadcasting System requesting verification cards on W2XE, Columbia's new international shortwave transmitter at Wayne, N. J.

The station has been in operation since 1929. Early this year, however, the installation of a completely new transmitter has caused letters to pour in to the station from every corner of the globe. The high-fidelity transmitter is licensed to operate on the frequencies 6120, 11830, 15270, 17760, and 21520 kc/sec. The equipment used is the RCA ET4310, 10KW short wave transmitter.

Short-wave tests for determining the effectiveness of directional

antennas were recently undertaken by station W2XE in collaboration with the British Broadcasting Corporation. The tests are being conducted under the auspices of the Union Internationale de Radio-diffusion (International Broadcasting Union) at Brussels, Belgium. Data uncovered by the tests are to be used as the basis for recommendations to the forthcoming world radio conference in Cairo, Egypt. During the course of the test transmissions, W2XE will operate during the next few months on the following schedule:

Freq'cy	Time	Antenna Direction
21,520 kc	1130-1400 G.M.T.	Europe
	1400-1430 G.M.T.	South America
15,270 kc	1900-2130 G.M.T.	Europe
	2130-2200 G.M.T.	South America
11,830 kc	2230-2300 G.M.T.	Europe
	2300-0400 G.M.T.	South America

W2XE Program Facilities

The growing importance of short wave program transmission on a world-wide basis has led to Columbia's establishment of a special W2XE program department, located in CBS headquarters at 485 Madison Avenue in New York. In charge of the department is Miss Elizabeth-Ann Tucker, formerly of the CBS General Engineering staff. Programs of exceptional international interest over the nation-wide network of the Columbia Broadcasting System are broadcast over W2XE with announcements in four languages—French, English, German and Spanish. Other programs are arranged expressly for W2XE's international audiences and are not heard over the national network.

The increasing number of short-wave and all-wave receivers in all countries has opened up a vast new audience for W2XE's program offerings. "D.X.-ing" is no longer the exclusive pleasure of technically-minded listeners, but has spread to thousands wholly unschooled in radio engineering. Their demand is for the best in entertainment, and Columbia is making an effort to provide it for them at peak listening hours in both hemispheres.

Technical Facilities

The W2XE technical facilities provide equipment for short-wave international broadcast service and incorporate the latest developments of the radio art, developments which heretofore have been applied only to transmitters operating at conventional intermediate or low broadcast frequencies. These developments include such features as all a-c operation,

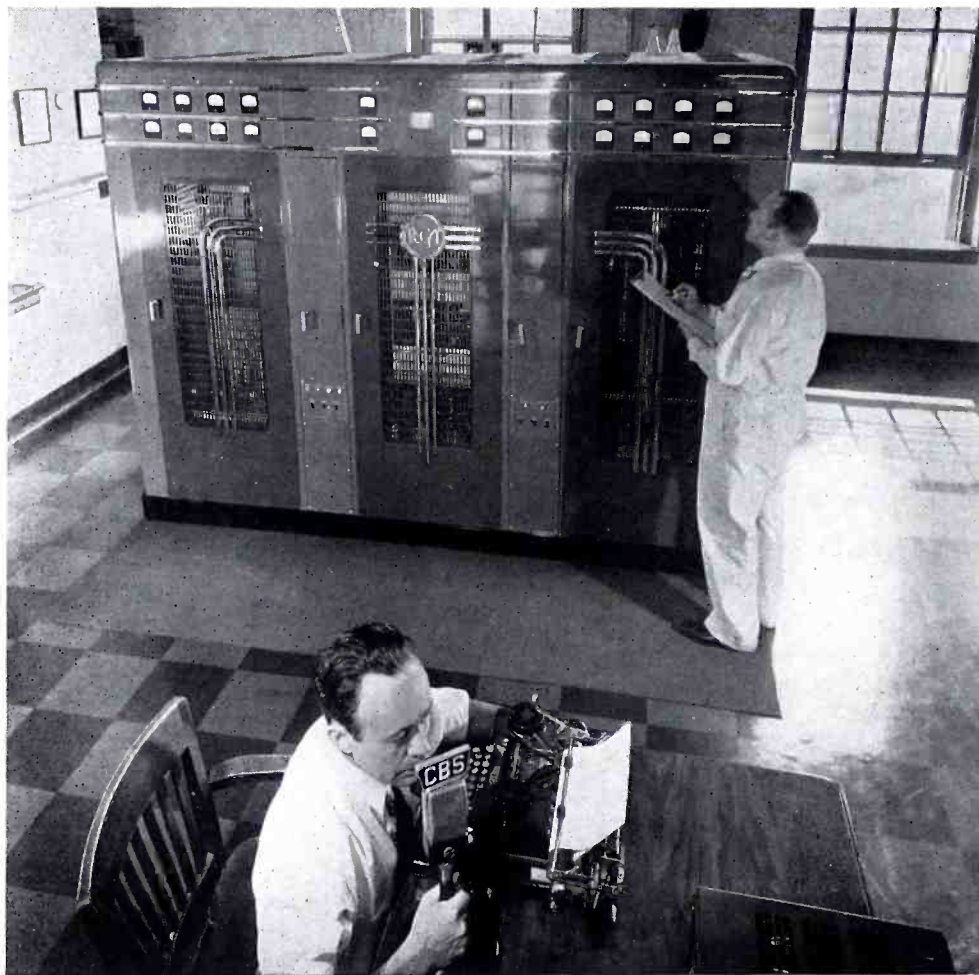

On the air and on their way! The programs from W2XE go out over the new RCA 10KW short wave transmitter to entertain listeners of many lands.

high level modulation, elimination of fuses in all power and control circuits, substitution of ceramic coils in place of the rubber hose coils previously used for insulating the high power vacuum tubes from the water supply and the elimination of all wood insulation from the equipment. The new plant has exceptional fidelity characteristics. The audio frequency characteristic of the transmitter is substantially flat between the frequencies from 30 to 10,000 cps. The response is uniform within 1 db from 100 to 5000 cps and within ± 1.5 db from 30 to 10,000 cps. The r-m-s values of audio harmonic distortion, within the range of 50 to 7500 cps, do not exceed 4% for any single modulating frequency between 0 and 100% modulation.

The unweighted overall noise level at this transmitter is more than 50 db below 100% modulation. This low level is partially secured through a-c filament operation. Low level audio frequency amplifier tubes are provided with indirectly heated uni-potential cathodes. All radio and audio stages are connected in push-pull, and an additional reduction in hum is obtained by connecting the tube filaments in the last radio stage on a two-phase supply, thus partially cancelling the hum. Hum compensating apparatus is employed which introduces into the



Here in Mexico City, audiences tune in the interesting programs from the CBS station.

audio stages 60, 120 and 180 cps, 180 degrees out of phase, with similar frequencies generated by the transmitting equipment.

The carrier frequency range of this station is from 6.0 mc to 21.52 mc. Each operating frequency is maintained constant by quartz crystal control. The quartz plates used are cut on a special axis with respect to the X and Y axis of the crystal and as a result the frequency variation with change in crystal temperature is negligible. Furthermore, these crystals have a high output and stable, parasitic-free operation. The frequency deviation of this station does not exceed plus or minus 0.01 of 1%.

Quartz Crystals

Four quartz crystals are provided, each with its own oven. The complete oven is equipped with plugs and may be quickly and easily removed to be replaced by another unit. Any two crystals may be switched into the operating circuit and then become part of the frequency change mechanism. The proper crystal is selected by the frequency change switch. The crystal oscillator circuit is one which has resulted from considerable research and development. It combines high output with stable, constant frequency operation. Provision is made for slight frequency changes by manual control, without resorting to changing the dimensions or adjustments of the crystal itself.

The crystal oscillator is followed by a buffer stage, a frequency doubler stage, a second doubler, and two amplifier stages, which operate at the fundamental frequency. The final amplifier utilizes two water cooled tubes. Each stage is shielded and the output stage is connected in push-pull and neutralized. Adequate insulation is provided to prevent breakdowns which might be caused by over-modulation surges.

The problem of high speed frequency change was solved by



A lovely septet from old Havana which probably listens in with a critical ear.

(Continued on Page 6)



In Buenos Aires appreciative audiences dial W2XE.

IMPROVED SERVICE

(Continued from Page 5)

providing two independent tank circuits for each stage, one for each of the two frequencies it is desired to use. All adjustments for each frequency may thus be permanently set up independently, with the assurance that no change made for one frequency will affect tuning on the other frequency. The power amplifier tank circuit adjustment is accomplished by a solenoid operated frequency change switch which permits instantaneous frequency change by means of a single switch.

Audio System

The audio system consists of two push-pull amplifier stages, and a high level Class B modulator. The modulator, which also employs two large water cooled tubes, is coupled to the radio frequency output stage through a transformer. A filter prevents the d-c components of plate current from flowing through the transformer.

Three rectifiers provide all of the d-c voltages required in the transmitter. The first consists of two hot cathode, mercury vapor tubes, in a single phase full wave circuit. The rectifier develops approximately 2500 volts d.c. It supplies plate voltage for the crystal oscillator and the buffer amplifier. It also supplies bias voltage for the second audio amplifier and modulator. The second rectifier employs three mercury vapor rectifiers in a three phase, half wave, rectifier and supplies 1800 volts d.c. for the intermediate power

amplifier and the two frequency doubling stages. This potential is reduced to 1300 volts for the first frequency doubler, and 1600 volts for the second doubler. The main rectifier consists of twelve hot cathode, mercury vapor rectifier tubes in a double three phase, full wave circuit. The two-three phase sections are connected in series. The d-c output voltage is 10,500 volts. Taps are provided at 50 and 75% maximum voltage.

An automatic induction voltage regulator is supplied which regulates the line voltage to a constant value for the entire transmitter eliminating all difficulty with fluctuating voltages and output. The regulator will compensate for a 10% change in primary power supply.

Protective Devices

Protective devices guard against excess plate current and inade-

quate flow or excessive temperature of cooling water. Reliability is insured by simplicity of design and conservative rating, while meters in radio and power circuits make it possible to observe operating conditions at all times.

A closed circuit cooling system is supplied, consisting of a circulating pump, radiator and blower assembly and a supply tank. Distilled water is used since water of high mineral content causes scale formation on the anodes of the radiotrons. Since the entire water system consists of porcelain and copper, there is no chance of contamination of the water, which may therefore be used for long periods without replacement. The water cooling system, which requires approximately 60 gallons of water, has a cooling capacity conservatively rated at 25 kw continuously for an ambient temperature not exceeding 115 degrees F.

Directional Antenna Systems

W2XE is primarily interested in serving Europe and Central and South America. To increase the field strength of this station in these directions, antennas have been erected, and are now in daily use, capable of giving an average gain of ten times in desired areas. European coverage, from directional antenna design standpoint, is not as difficult as South American coverage since the great circle paths from New York to most of the important

(Continued on Page 28)



Even in far away places the natives hear the CBS short wave station.

STREAMLINED CONVENIENCE

A Minor Detail Becomes Important

By JOHN VASSOS

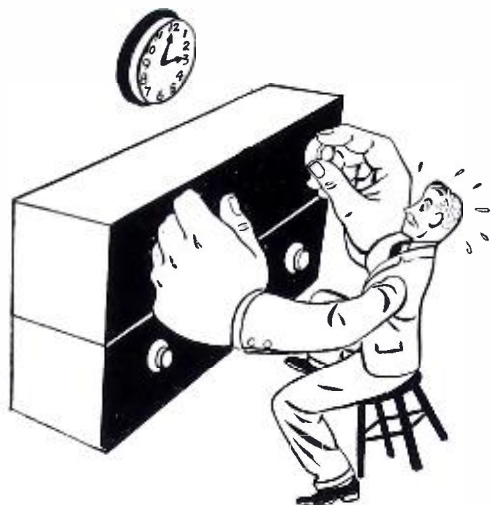

Gee! Are my hands heavy after a session with these old knobs.

SOMETIMES an apparently insignificant object is given a great deal of attention and one wonders whether the mountain brings forth a mouse or vice versa.

And this was the dilemma with which we were faced when it came to the problem of redesigning and standardizing the knobs for our various types of speech input equipment. At the first glance, the problem seemed to present a rather easy solution, which was, to smooth and clean the surface of the old-fashioned knobs, but, as the analysis proceeded, certain other pertinent facts were exposed. On active equipment, the control engineer spends hours manipulating these knobs without interruption, and also the fact was brought out that oftentimes the control engineer is in a sitting posture when working, changing the angle of the forearm to an entirely different plane and leverage of action as compared to the operation when standing. So, as the importance of this lowly object began to achieve gigantic proportions in its solution, a survey was taken to determine even further factors in trying to arrive at, and cover

practically all conditions under which the knob would be used.

Broadcasting stations and radio centers were approached for vital information. First it was necessary to arrive at the general proportions of the hand of the average radio engineer, assuming that, due to his particular type of work the hand development would be different than the average person. Then a plastic, soft putty similar to that used by sculptors was constantly molded and remolded until its overall form was of such size and proportions to suit this average hand, with the result that the most favorable proportions and dimensions were determined: It has no sharp or angular protrusions but soft indentations that act as a sure grip.

Another fact was disclosed. Seventy-five percent of the control engineers rested their hands on the knob by hooking the middle and index fingers over the knob and in a manner suspending and resting their entire arm thereon, and at the same time manipulating the knob. This meant in a short period of time the complete disfiguring of the panel proper and the rubbing out of the calibrated numerals. Often callouses and infections developed on the hands of the operator from the metal pointer that existed on these old knobs. Conse-



So you didn't realize how important I was?

quently, a flange was added at the bottom of the knob to prevent marring of the numerals of calibration and an integral fin was provided to act as the pointer, starting from the bottom of this protective flange and, in a streamlined fashion, blending into the top of the knob, the pointer portion extending from the center of the knob. This resulted in a beautiful and efficient form which had no sharp or angular protrusions foreign to the contours of the human hand, and assured protection for the instrument panel proper by the above mentioned flange.

(Continued on Page 24)

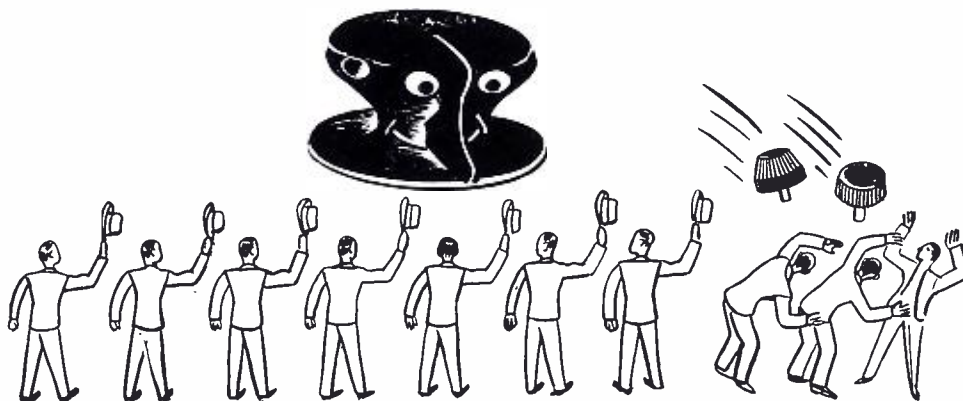

The Winnah! So say seven out of ten engineers.

GOING PLACES IN DIXIE

New Plant and Equipment Bring WRDW to the Front

By J. L. TALLEY

FAVORED by its geographical location and ample financial backing, the new station at WRDW is setting a high standard for broadcasting in the deep south. Since 1929 Augusta, and the surrounding territory in Georgia and neighboring South Carolina, have been served by a small 100 watt transmitter.

A far sighted policy of efficiency and service was instituted about a year ago which has resulted in very marked progress. In keeping with this program our competent chief engineer, Mr. Harvey J. Aderhold, was instructed to plan an entirely new transmitter — regardless of cost. On the fifteenth of July the last of the old equipment was discarded, and greater WRDW was officially "on the air."

Spacious Quarters

The studio, which is located in down-town Augusta, occupies the entire second floor of a new marble faced building. Although this was the first of the new units to be completed, it has only been in use for a little less than a year. The spacious quarters include offices for the station manager, the program director and the advertising department, and accommodations for studio visitors. In the operating department there are two large sound-proof studios, each equipped with three RCA high fidelity microphones, together with the main and auxiliary control rooms. The flexible control units and standard sound equipment are already well known to radio engineers and a further description of them is not warranted here.

The transmitter had been broadcasting, under adverse conditions from down-town Augusta, and it was necessary to find a more favorable location. This RCA transmitter, like an old friend, deserves a comment in passing. Installed in 1929, the old 100W RCA set has broadcasted faithfully for seven years. Recently a radio engineer

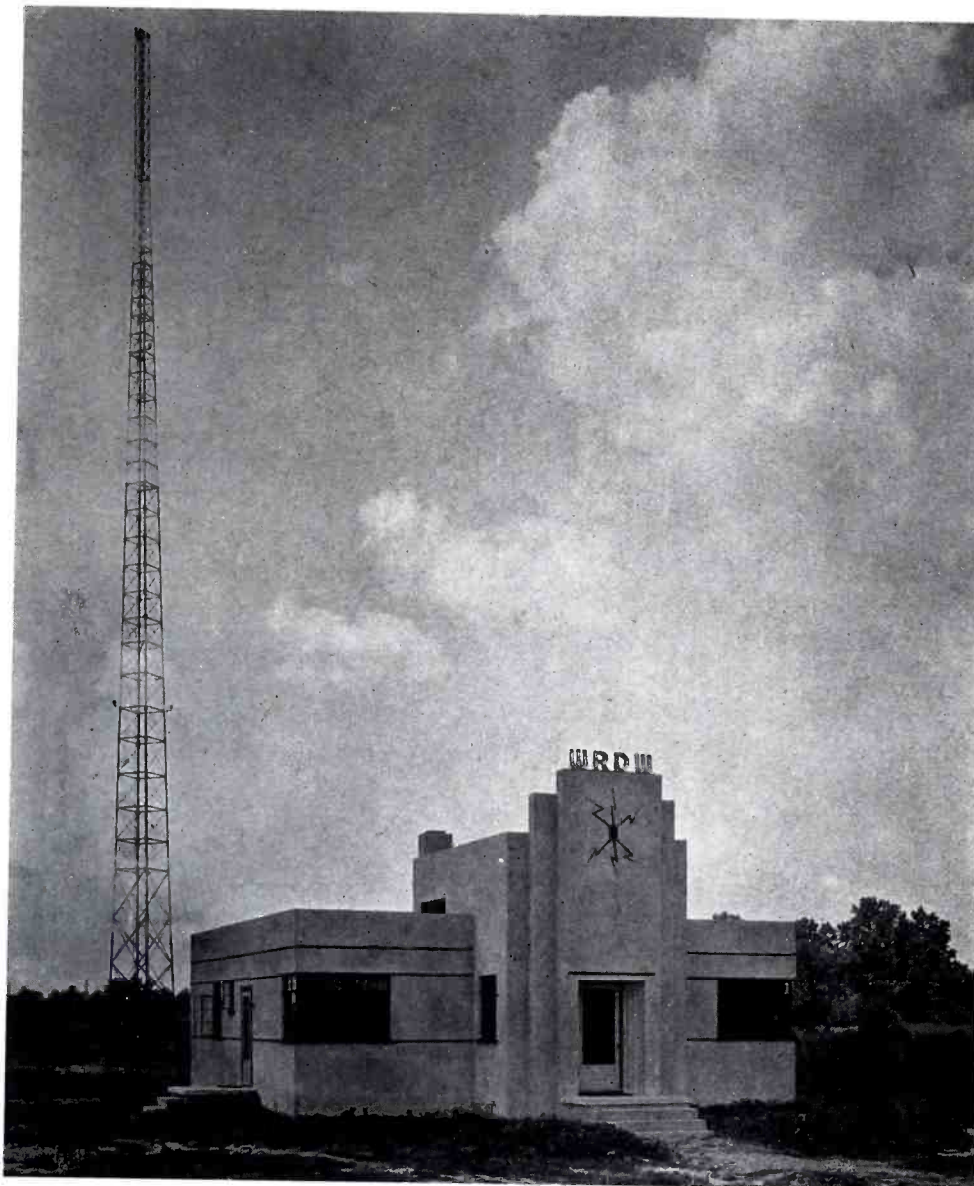

The new transmitter house and vertical antenna of WRDW located on the outskirts of North Augusta; South Carolina.

carefully inspected every part of the old transmitter and declared that it was in perfect condition for future service. The 100W is now serving as a stand-by, ready for instant use should an emergency arise.

New Antenna Site

Mr. Harvey Aderhold was commissioned to locate a new antenna site. Two or three likely places were found after a painstaking survey of all the country within a five mile radius of Augusta. His final selection of a site was checked by the Holey and Rollins radio engineering firm of Atlanta. Their field engineer, using a portable 50 watt oscillator, made accurate field intensity measurements and graphs around each of

the proposed antenna locations. By a process of elimination the search finally centered on a high plateau in the open country directly across the river from Augusta. Here Mr. Aderhold had already located an abandoned rice field with the required moist land that was fed by seven springs. Later experience gained after broadcasting from this location have confirmed the efficiency predicted by these early field intensity measurements.

A modern stucco house has just been completed that provides accommodations for the transmitting equipment, a spare studio, and living quarters for the chief operator. The building is modernistic in design, with large windows,

(Continued on Page 24)

PRESS MISTAKES ABOUT MARCONI

Some Common Mis-statements Are Corrected

By G. H. CLARK

THE death of the inventor of wireless has let loose in the press of this country a mass of misinformation regarding his life. Many of these stories have persisted for many years although some are of recent origin. Mr. Marconi, one of whose main characteristics was an intense love of accuracy, felt very hurt by many of these manufactured stories, and did what he could to counteract them during his life. That he did not succeed is clearly shown by the press stories of his career, issued after his death had been made known.

In a letter dated March 3, 1937, he writes as follows:

"Certain myths seem to have taken deep root in the imagination of historians, such as my having been a pupil of Augusto Righi and having frequented the Bologna or other universities. Another story, arising from nowhere, is the adversity of my father to my work; as a cautious businessman, he was not so enthusiastic, at first, as my mother; but he was not in the slightest adverse to it."

Other incorrect statements on Marconi's life, which have appeared in the press stories of his demise, are:

1. That he got the idea for using Hertzian waves when he was using a heliograph in the Italian Army, when he was 20 years old, in 1896. This has not even a shred of basis. He was not in the military service until years after. The facts are these:

a. According to Italy's conscription regulations, Marconi would have been called up for service in the army when he reached the age of twenty, and would have had to serve for three years, but there was a clause in the law whereby if an applicant passed a certain rigorous military examination, he would serve as an officer rather than as a private, and his term of service would be lowered to one year. Moreover, he would not necessarily have to begin his service at the age of twenty, but



A photograph of Marconi presented by him to the author.

could do so at any time before attaining his twenty-sixth year. Marconi passed this examination, and it was not until he began his work actively in England that the matter of his military service came up. (This is from official testimony of Mr. Marconi.)

b. In 1892 Marconi made some experiments with a heliograph, while spending the summer with his parents in the mountains. These were the usual experiments of youngsters, but Marconi often has stated that the germ of his later invention of wireless communication lay in this early work with mirror communication.

2. That Marconi had "attained a distance of 120 miles before he offered his invention to the Italian Government, and before he went to England to exploit it." He offered his idea to the Italian Government after he had attained 1¾ miles, the limit of his father's estate, and did no more work with the idea until after he went to England. By 1899, three years after he arrived in England, the maximum distance attained was around 85 miles.

3. That he, "to put his request in due form, heralded his coming" (i. e., to England), "by sending a message across the English Channel." This is not the case. It was not until 1899, three years after arriving in England, that cross-

channel communication by wireless was established.

4. That, in his famous conquering of the Atlantic Ocean by wireless, in 1901, he "heard three faint clicks in the telephone." This error is almost universal. The facts are:

a. Marconi first used a coherer, with decoherer and Morse register, in attempting to pick up the signals from across the ocean. There was so much interference from atmospheric that he could not get any readable signal—the coherer was responding almost all the time, and the Morse register was chattering in time with it. The moving up and down of the inking bar of the Morse register produced "clicks," and if he had heard the historic letter "S" on the Morse register, (in addition to seeing them printed as three dots on the register tape), the "click" myth would have been correct. But nothing of the sort happened.

b. Marconi then turned to another form of detector, with which a telephone receiver would be used. In this case, the signal from Poldhu would be heard with its characteristic note, an alternating current hum. This would to a degree be contrasted with the sharp "cracks and clicks" of static, and hence there was a chance to perceive the signal. So Marconi listened. He finally heard—not three "clicks," but three "buzzes," just as an operator many years later would hear from a spark transmitter, when using a crystal or an electrolytic detector and head telephones. Not "clicks," but buzzes!

5. That Marconi had developed a secret "death ray," by which automobiles and airplanes could be made inoperative by "pressing a button." This idea of the lethal possibilities of wireless is as old as the art itself. In *The Windsor Magazine*, published in London, July, 1899, the question of wireless being able to blow up the magazines of ships during war was put up to Marconi, and with his characteristic humor he replied that if "he could get inside the magazine and place the right machine in it" he could do so. In more recent years he has definitely denied that he was planning any special

(Continued on Page 30)

SPACE BECOMES A FACTOR

New Console Features Compact Design

By C. M. LEWIS

THE trend of broadcasting studio equipment design has been advancing toward a more simplified installation and emphasis is being placed upon operating convenience. Faders and control keys have been removed from the racks and placed in consoles located directly in front of the studio window. Such an arrangement has reduced the strain and movement required of the operator and enabled him to perform his duties in a more efficient manner, thereby reducing errors to a minimum.

It is only natural that this evolution of design should lead to the idea of enlarging the desk console so that it could enclose all the amplifying equipment, eliminating the standard rack and its associated panels. Although the rack and panel scheme still remains the most flexible arrangement, many progressive broadcast engineers are now favoring the console type of equipment for certain installations. It is the purpose of this article to describe the new RCA 76-A Console which has been designed to incorporate a complete speech input system in a single cabinet.

Flexible in Use

Although primarily designed for operating two studios, the Console is well suited for use in the individual control booths of multi-studio installations. The circuit and switching facilities have been arranged so that six microphones and six remote lines may be quickly and conveniently controlled. A separate mixing pad and associated input key switch may be used for other remote lines or for switching and mixing the outputs of two transcription turntables. Switching facilities have also been provided for auditioning a studio rehearsal while broadcasting transcriptions (and remote pickups) or vice-versa.

As shown in the simplified schematic diagram, the unit comprises three separate amplifiers, each of which has been especially designed for its position in the circuit. The preamplifier-mixer unit is identical with the RCA 58-A tri-amplifier and consists of three single tube preamplifiers with mixing potentiometers in their plate circuits. The outputs of the potentiometers are combined and fed into a single tube booster amplifier. Turn-key switches are located

directly ahead of the mixing potentiometers and allow their inputs to be switched either to the plate circuits of the preamplifier tubes or to the arms of other key switches for mixing external circuits such as remote lines. The inputs (50/250 ohms) of the three preamplifiers are also connected to key switches which allow them to be easily transferred between microphones located in different studios. The latter switches have contact arms which open the loudspeaker relay circuits to any studio in which a microphone is being used. The wiring to one of the switches has been arranged for an announce microphone in the control booth.

The output circuit of the tri-amplifier goes through a turn-key switch (TW-1) by means of which it may be connected to the input of the studio amplifiers for broadcasting or to the monitoring amplifier (through the monitor transfer switch (TK-1) by means of which key switch (K-8), is used to transfer either of two external circuits to the input of a 250 ohm ladder-type attenuator, the output of which is connected to a "program-audition" key switch (K-7). The "program"



Front view of the 76-A, Two Studio Console.

outputs of the two "program-audition" switches pass through the master mixer and a jack circuit to the input of the studio amplifier.

Studio Amplifier

The circuit of the studio amplifier is essentially the same as that of the standard RCA 40-C Program Amplifier. It contains an integral power supply which also furnishes plate voltage for the preamplifier tubes. The output of the studio amplifier is terminated on a key switch for transferring to either of two outgoing lines.

The monitoring amplifier is a high-fidelity unit with 75 db gain and is capable of 8 v/m.

It contains its own power supply which is designed and wired for furnishing current to a 100 volt loudspeaker field connected to the loudspeaker relay. A vari-

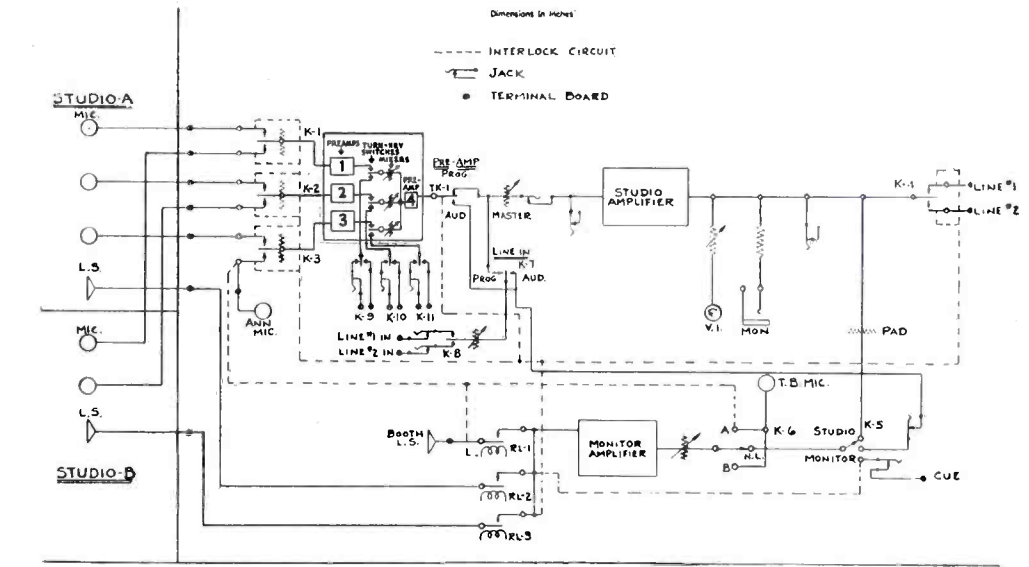

Simplified schematic of the 76-A.

control booth. The relay circuits have been wired so that the booth speaker is off when either of the announce or talk-back microphones is in use.

switch mounted on the front panel, the VI Meter is also used for checking the plate currents of all the tubes in the program amplifying circuits. In the normal operating position it is connected across the output of the studio amplifier through a variable attenuator.

The location of the various controls is apparent by referring to the photograph. The attractive wooden cabinet is finished in two shades of grey and all the controls are mounted on three grey, etched-metal panels. The center panel which contains the VI Meter, program key switches, and the mixers is set slightly forward and sloped to provide maximum visibility and ease of operation. The cabinet dimensions are 52 inches long, 12 inches high, and 20 inches deep. These dimensions allow for convenient installation while providing plenty of mounting space for full sized equipment.

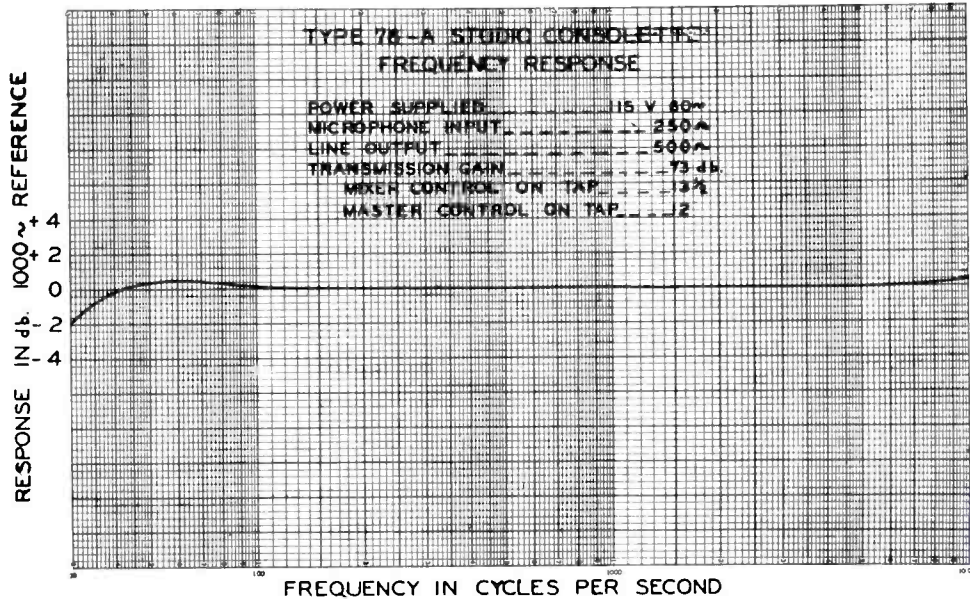

able attenuator is used in the input circuit as a volume control and the input may be connected to the talk-back microphone, the output of the studio amplifier, the "audition" positions of the two "program-audition" switches, or to an external "cue" circuit.

By means of the jacks which have been provided, a remote pickup circuit may be patched into the monitor "cue" circuit for auditioning or for pre-broadcasting tests. The output of the monitoring amplifier is connected through the three loudspeakers cut-off relays to terminals for wiring to the speaker voice coils (approximately 15 ohms each). A normal installation for the speakers would be one for each of the two studios and one for the con-

Plate Current Check

The VI Meter is illuminated and enclosed in the new RCA streamlined case. By means of a rotary

(Continued on Page 25)

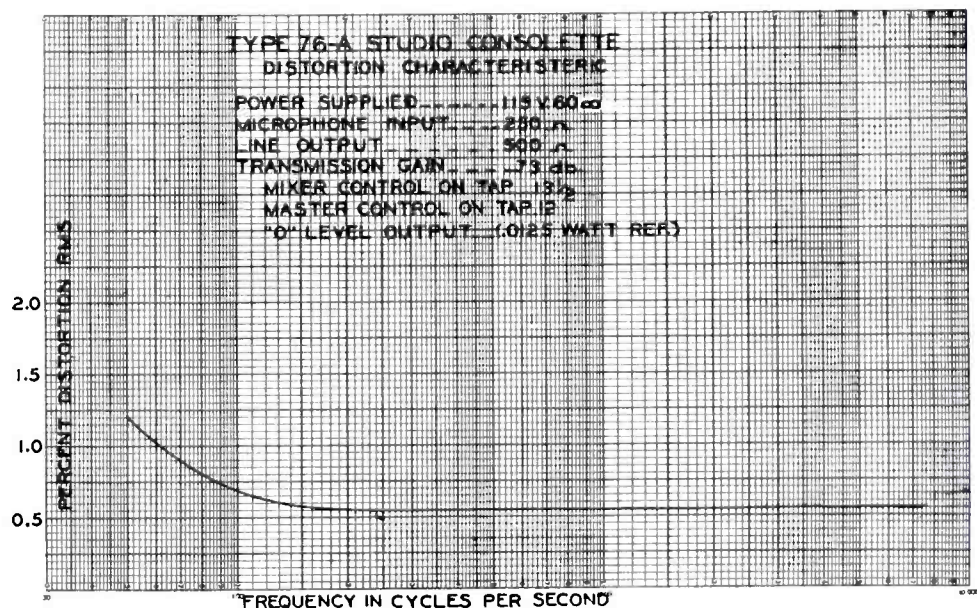

LIGHTNING IS A MENACE

Some Suggestions to Broadcasters for the Prevention of Serious Damage

By J. E. YOUNG

THE subject of lightning protection is of utmost importance to the broadcast station engineer, since in many sections of the country the majority of transmitter outages, during the summer months, result from the effect of lightning, either direct hits or voltages induced as a result of a stroke of lightning within the vicinity of the station. In spite of the importance of this subject there appears to be very little information of a practical nature available to the broadcast engineer. The following paragraphs describe what is generally considered to be good practice in the installation of lightning protection for small and medium power transmitters.

Type of Protection

The type of protection required depends to a large extent upon each individual installation. For instance, upon whether an open-wire transmission line is used, whether the transmission line is balanced and ungrounded, etc. The protection to be used upon the antenna itself is contingent upon the type of tower lighting circuits used and the protection built into the tower by the manufacturer in the shape of safety gaps.

The antenna should be protected by a radio frequency choke



Natural lightning stroke photographed from G-E Pittsfield lightning observatory.

connected from the antenna lead-in terminal to the ground system. This choke should have sufficient inductance so that the radio frequency current flowing through it as a result of the normal operation of the equipment will be small. The radio frequency voltages encountered in the usual antenna system for low or medium power transmitters is not very great, consequently, it is quite easy to obtain sufficient inductance to meet this requirement. It

then becomes possible to use a relatively small conductor, such as No. 20 or No. 22 B & S. Double cotton or double cotton plus enamel insulation should be used. In order to reduce the potential gradient across the first few turns of the choke, it is advisable to space wind the first several inches of winding. The spacing between turns should be variable, starting from approximately one-quarter inch between the first several turns and smoothly decreasing until after several inches of winding the turns actually touch. As a further protection it is advisable to wind the top turn of heavy bare wire, such as No. 8 B & S. This will prevent arc-overs from jumping to the smaller wire with which the choke is wound, and may thereby save it from destruction. The completed choke should be given several coats of bakelite varnish to make it moisture proof.

Use of Lighting System

If a tower lighting system is used in which the lighting power is carried to the tower through radio frequency chokes, one side of the lighting circuit may be used as a static drain circuit by tying the tower to the lighting circuit, and grounding the low potential end of one of the corresponding isolating radio frequency chokes.

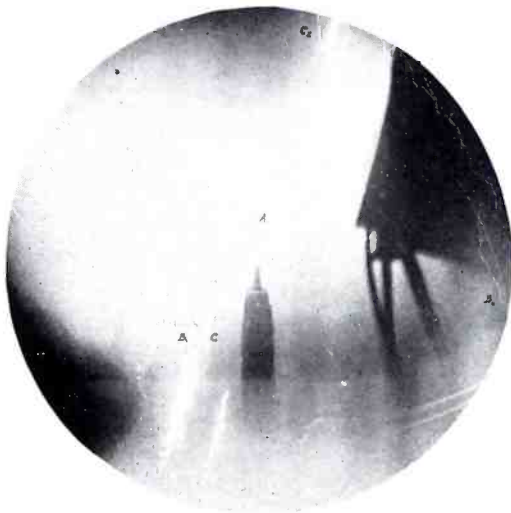

- A. Continuing multiple stroke to Empire State Building.
- B. Multiple stroke to 60 Wall Street Tower.
- C. Multiple stroke to Bank of Manhattan (Wall Street).



- Photos: Courtesy of G-E
- A. Continuing multiple stroke to Empire State Building.

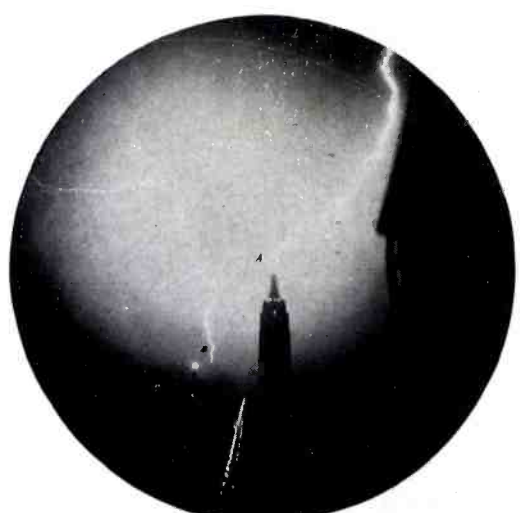

- A. Continuing strokes to 60 Wall Street Tower.

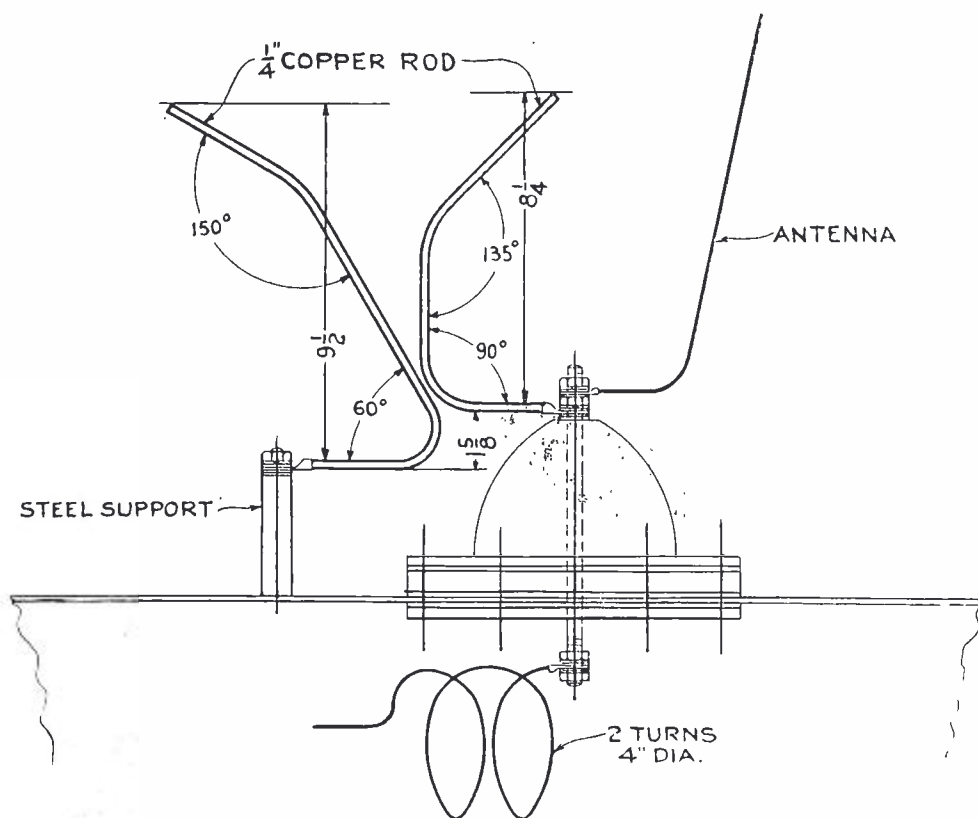

ANTENNA TUNER

Fig. 1. Horn gap arrangement.

A radio frequency choke coil such as is described above will be effective in preventing the accumulation of a high voltage on the tower due to induction from several successive lightning discharges in the vicinity, or potentials set up by wind, sand storms, rain, etc. Disturbances of this nature tend to build up a slowly accumulating voltage on the an-

tenna as successive charged particles come in contact with it. The drain choke presents little reactance to voltage built up at such a low rate, consequently the static charges leak off to ground as rapidly as they are collected by the antenna.

Removing High Voltages

Static drain chokes provide no protection against direct hits by

lightning or the extremely high voltages induced into an antenna by a hit in its immediate vicinity. The wave front of the voltage induced into the antenna under such circumstances is so steep that the drain choke offers a very high impedance to it. A spark gap is the only practical means of removing these high voltages from the antenna. The gap must be so designed that it will break down at voltages only a few times the normal peak radio frequency voltage produced by the transmitter, and it should be constructed so that it will clear the arc which follows the static discharge. Figure 1 shows the dimensions and method of installation of a horn gap which is expressly designed to give this type of protection. The curvature of the horns and their placement in the vertical plane is such that very close spacings can be used without danger of a steady arc. The angle that the surfaces of the horns makes is such that any arc is extremely unstable and tends to travel rapidly up both horns until it reaches a gap too great for it to sustain itself.

(Continued on Page 28)



A single stroke which scores a direct hit.



Two strokes which miss the tower.



Single stroke to the Empire State Building.

A NEW LIMITING AMPLIFIER

96-A Features Low Distortion, Convenience

B. W. ROBINS and J. M. BRUMBAUGH

THE 96-A amplifier is a three-stage high-fidelity program-channel amplifier. Its chief divergence from conventional amplifier design lies in the fact that, as its name states, it is a limiting amplifier. That is, when the input signal exceeds a pre-selected level, the gain of this amplifier is automatically reduced an amount depending upon the increment of the input above that pre-selected level. Thus, it limits its output to a pre-determined level for inputs within its specified range. It performs as a conventional amplifier, output being directly proportional to input unless the input signal exceeds the previously mentioned pre-selected level, which we shall hereafter call the "critical level."

When the input is increased by 20 db from this critical level, the output will increase approximately 2 db; that is, while the voltage input is raised tenfold, the voltage output increases only about 22%. Stated in still another way, when operating entirely below critical level, a 10 db change in input produces a 10 db change in output but when operating entirely above critical level, a 10 db increase in input produces approximately 1 db rise in output. The "compression ratio," to borrow a term from the automotive industry, is thus about ten to one.

The primary function for which this equipment was designed is

that of reducing overmodulation of radio broadcast transmitters. Conversely, it permits raising the average radiation level by several db without the usual result of frequent overmodulation. Well-known bad effects of overmodulation are increased interference, distortion, transmitter "off-ons," and actual damage to the transmitter in some instances. Although the insertion of a Type 96-A Limiting Amplifier in the audio channel of a broadcast transmitter does not provide absolute protection to the transmitter against all possible audio overload conditions, its gain-reducing action is fast enough to help greatly in this respect.



The 96-A matches the RCA De Luxe Speech Input Line.

Low Distortion

The Type 96-A Limiting Amplifier has the characteristic of a slow return to normal gain after a high-level input signal is removed. For example, suppose an input signal which is 10 db above the pre-selected point at which gain-reduction begins is suddenly removed. The gain of the limiting amplifier will immediately start increasing, but several seconds will elapse before its gain has returned to normal. This very slow return time is provided for two reasons. It prevents the gain from rising at a sufficiently rapid rate to make very noticeable changes in background noise. It also prevents the gain from rising an appreciable amount during one cycle of a low-frequency audio signal, thus introducing very little distortion even at the lowest audio frequencies.

The Type 96-A Limiting Amplifier proper consists essentially of three push-pull amplifier stages in the program channels, a single-stage control amplifier, and a full-wave diode rectifier. An especially-designed regulated power unit is available for AC operation, this being a separate unit.

Briefly, the gain-reduction in the amplifier is accomplished in the

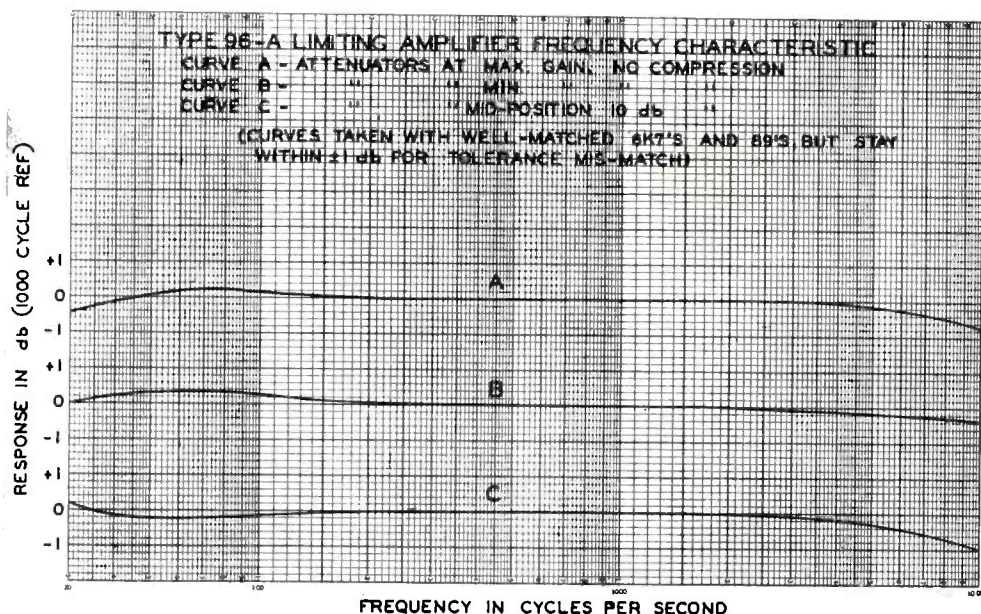

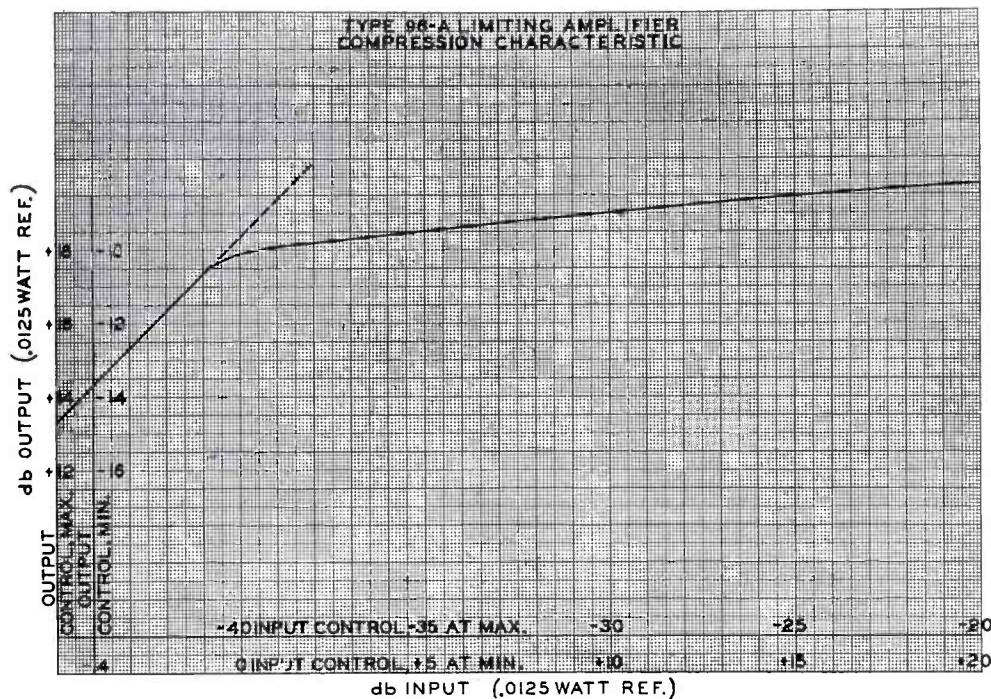

following manner. A portion of the audio signal appearing across the secondary of the interstage transformer excites the control amplifier. This in turn supplies signal to the full-wave diode rectifier. This rectifier has a rather high negative bias so that normally it passes no current. However, when the input signal exceeds the critical level, this diode rectifier passes current, producing a unidirectional voltage which is applied as an increase in negative bias to the grids of the first stage in the program channel, thus reducing the gain of the amplifier.

Performance Characteristics

The performance characteristics of one Type 96-A Limiting Amplifier are listed below. This list is not intended to be a guarantee of the performance of all 96-A amplifiers but is rather included to give an indication of performance. Due to tolerances encountered in production, these characteristics will be subject to variation.

1. Percent total R.M.S harmonic distortion at 400 cycles:
 - (a) 0.5% with +18 db output (.0125 ref.) and 18 db compression.
 - (b) 0.2% with 0 db output (.0125 watts) and no compression.
 - (c) 0.4% with 0 db output and 18 db compression.
2. Frequency response. Limits: ± 1 db from 30 to 10,000 cycles (1000 cycle ref.) for all rated conditions of operation.
3. Total hum and noise level with proper adjustment of hum control: at least 75 db below normal signal level.

4. Terminal impedance 500 ohms (balanced).

5. Time required for gain-reduction to become essentially complete: 1 millisecond or less.

The Type 96-A Limiting Amplifier has many design features which will facilitate initial installation, operation, and maintenance. Electrically some of the more important ones are:

1. An input attenuator on front panel providing 0-40 db attenuation in 2 db steps — scale marked directly in db input for critical level.
2. An output attenuator on front panel providing 0-28 db attenuation in 1 db steps — scale marked directly in db output at critical level or level to which output is limited.
3. The single meter provided on the equipment serves all of these functions:

(a) Output VI

- (b) Gain-reduction indicator
- (c) Checking all plate currents
- (d) Checking "B" supply voltage
- (e) Checking "A" supply voltage (if DC is used)
- (f) Dynamic match indicator for input tubes.

4. All controls necessary to obtain Conditions 3(a) to 3(e) above are located on front panel. Switch on chassis available through hinged door on front panel provides Condition 3(f).

5. Continuous indication of compression in db — showing amount and frequency with which peaks are being compressed. Auxiliary VI function to monitor outputs below critical level.

6. Range of inputs at which critical level can be set: 0 to -40 db (.0125 ref.).

7. Range of output levels to which program can be limited. -10 to +18 db (.0125 ref.).

8. Total available gain with no compression: 58 db.

9. Auxiliary critical level adjustment (on chassis) which, together with output attenuator, permits close setting of limited output level.

10. Separate switch disconnects limiter circuit to facilitate set-up and check operations.

In mechanical construction, finishes and appearance, the 96-A Limiting Amplifier and separate Power Supply follow RCA's De Luxe line of speech input equipment. Notable features of this line are:

1. Ready access to all tubes and auxiliary adjustments through hinged doors in front panels.

(Continued on Page 30)

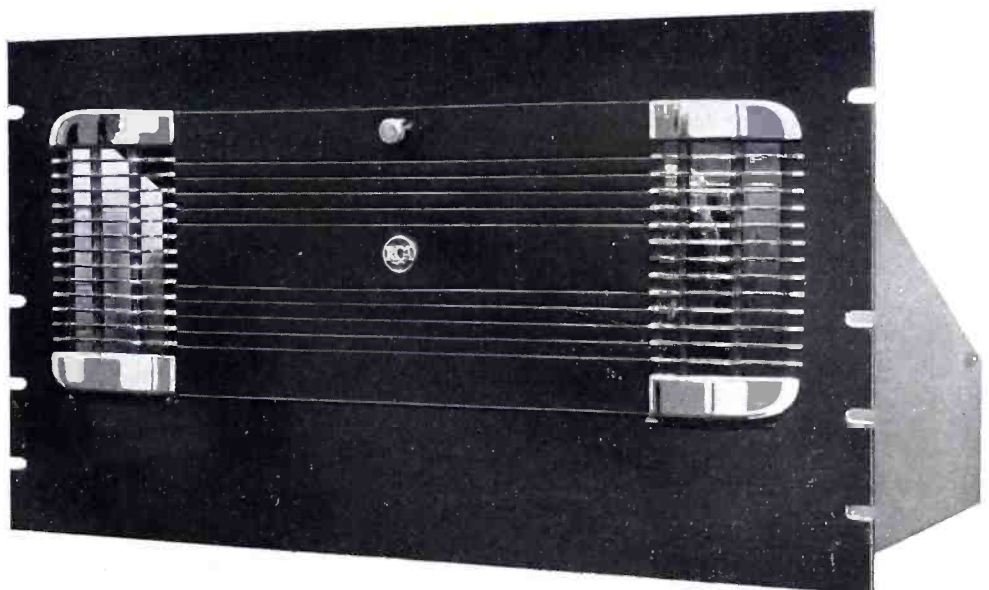

Front view of the Power Amplifier.

FURTHER NOTES ON EXTERNAL CROSS MODULATION

Additional Information Concerning An Increasingly Serious Problem

By DUDLEY E. FOSTER, RCA License Laboratory

SOMEWHAT over a year ago reports began to be heard concerning a type of interference with broadcast reception which had never before been noticed. The interference occurred only in localities having high field strength from one or more local stations, and its new characteristic was that the program of the strong local station was heard when the receiver was tuned to one particular other station, but not to still others. The effect was not due to lack of selectivity because, when tuning the receiver, the local station could be tuned out and then would reappear when a certain other station was tuned in. Occasionally two local stations would be heard together on a frequency which was quite different from that of either one of them.

Peculiarities

This type of interference also had other peculiarities. In the area in which it occurred, it would be found in one house whereas the house next door would be free from interference even when the same set was used. In those houses where it occurred, any make or model of receiver, including battery sets, experienced it. Still another puzzling factor was that the interference was not constant, being much more severe at some times than at others, and occasionally disappearing entirely for a period. In one case the interference was eliminated by opening the window through which the antenna lead-in passed, and in another case the interference was heard only when a certain bedroom light was turned on.

These characteristics led to the deduction that the interference was not caused in the radio receiver, but by some agency external to the receiver itself. This was further proven by laboratory

experiments with two signal generators simulating the desired and interfering stations. In the laboratory, inputs of three or four volts applied to the receiver did not cause interference, whereas, in the field at those locations having this type of interference, field strengths causing less than half a volt signal to be impressed on the receiver were present. Furthermore, decreasing the length of antenna did not eliminate the interference.

A survey was made to determine whether interference of this nature had been noticed in other parts of the country. Reports as a result of this survey showed it to be present in certain areas in or near the following cities: Cincinnati, Chicago, New York, San Francisco, Seattle and Washington.

Since by this time it was evident that the trouble was some form of cross modulation, and since it was exterior to the receiver, this type of interference was designated "external cross modulation."

A location was found where the cross modulation existed consistently and a study was made to determine the fundamental cause and a remedy. In this location, a battery receiver with a short antenna exhibited cross modulation inside the house, but when the receiver was a few feet outside the house, cross modulation ceased. A trap circuit in the antenna was of no benefit, which was further proof that the difficulty was external to the receiver. It was observed that at this location, as well as at others where the effect was serious, that the house wiring was of the knob and tube type and the service mains from the distribution transformer were overhead. A filter near the receiver, consisting of two 0.1 μ f. condensers across the line with the cen-

ter point grounded had only a slight effect on the interference, but an additional condenser across the line where it entered the house greatly decreased the cross modulation. It was further found that by placing the antenna at a distance from the power lines and using a shielded lead-in, the external cross modulation disappeared.

Spurious Frequencies

This experience showed that the cross modulation was due to rectification of radio frequencies in the power wiring, with resultant new, spurious frequencies being induced in the antenna or lead-in. Radio Signals were picked up by the power wiring or other metallic conductors near the receiving antenna and at some point along the conductor were impressed on a rectifier or non-linear circuit element. The characteristic giving the output current of a rectifying element is commonly expressed as a series expansion in ascending powers of the applied voltage, the applied voltage in this case being the radio-frequency signals present on the power wiring or other conductor. The power-series representation of the rectifier characteristic discloses the new harmonic and combination frequencies which result from the rectification process. A simple laboratory test confirmed the observations. Two antennas were placed a few feet apart and to one of them a radio receiver was connected. An impedance was connected between the other antenna and ground, and when a simple diode was connected across this impedance, cross modulation of the signals in the first antenna occurred.

The question arises as to where the rectifier may exist in the field. Wherever there is a poor connection between any two metallic

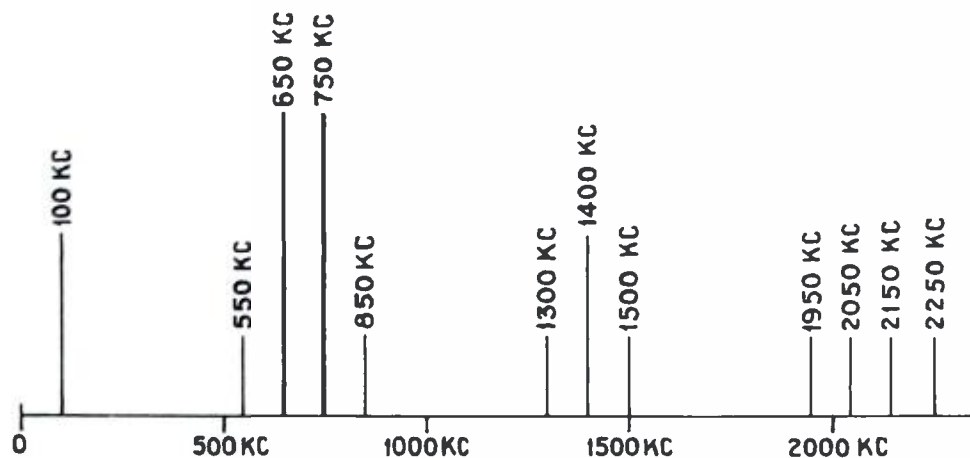

FIG. 1

bodies, especially if oxidation is present, rectification can take place. The poor contact may be in the lighting lines, in piping, or even in the antenna itself. In one case the trouble was located at a point where a pipe passed through metal wall lathing. Bonding the pipe and lath together eliminated the interference. In another case two pipes were found to be touching and insertion of a block of wood between them cleared up the cross modulation. When such a rectifier exists and one or more powerful signals are present, new frequencies are generated by the rectifier. Where only one powerful signal is present, the only new frequencies made by the rectifier are multiples of the fundamental, that is the second harmonic, third harmonic, etc. of the signal frequency. Where two strong signals exist, a number of cross modulation combinations take place. Let us call the frequency of one of the strong stations *a*, and that of the other *b*, then the rectifier generates the following frequencies:

$a + b$	$2a - b$
$a - b$	$2b + a$
$2a$	$2b - a$
$2b$	$3a$
$2a + b$	$3b$

An effect also takes place whereby the modulation of station with frequency *a* is heard on station *b*, and the modulation of station *b*, is heard on *a*.

It should be noted that these spurious frequencies do not depend upon the presence of a second harmonic from either of the stations. If both stations are entirely free from harmonic radiation these same frequencies are generated if a rectifier is present.

Let us suppose that two stations are so located that in the region between them signal strengths of 0.1 volt per meter occur from both, and that one station is on 650 kc. and the other on 750 kc. Then the following table shows the frequencies produced.

$a = 650 \text{ kc}$
$b = 750 \text{ kc}$
$a + b = 1400 \text{ kc}$
$a - b = 100 \text{ kc}$
$2a = 1300 \text{ kc}$
$2b = 1500 \text{ kc}$
$2a + b = 2050 \text{ kc}$
$2a - b = 550 \text{ kc}$
$2b + a = 2150 \text{ kc}$
$2b - a = 850 \text{ kc}$
$3a = 1950 \text{ kc}$
$3b = 2250 \text{ kc}$

These same frequencies are shown diagrammatically in Fig. 1. In this example these two stations would produce five new frequencies in the broadcast band and five new frequencies outside the broadcast band where one or both the stations together would

be heard. It can be appreciated readily that a large amount of interference will be produced in this manner. The interference produced by station of frequency *a* on frequency *b* and vice versa has been found to be serious only when the rectifying action is particularly severe, because the modulation of the strong desired station usually masks the interfering modulation.

Possibility of Hum Modulation

It may be seen also that there is a possibility of hum modulation being introduced when a rectifying condition exists in the power wiring. In this case, one of the frequencies is that of the signal carrier and the other that of the lighting system, which is usually 60 cycles. The rectifying action then imposes a 60-cycle modulation on the carrier. Some instances of modulation hum in receivers at certain locations have been traced to this source. Hum of this type would be present in a battery receiver at the same location. The remedy is the same as for interference between stations, namely elimination of the rectifying condition or changed installation of the antenna to avoid pick-up of resultant spurious frequencies.

Knowledge of the frequencies produced is helpful in determining whether a case of interference is due to external cross modulation or not. Most of the combination frequencies are readily calculated when the frequencies of the two

(Continued on Page 32)

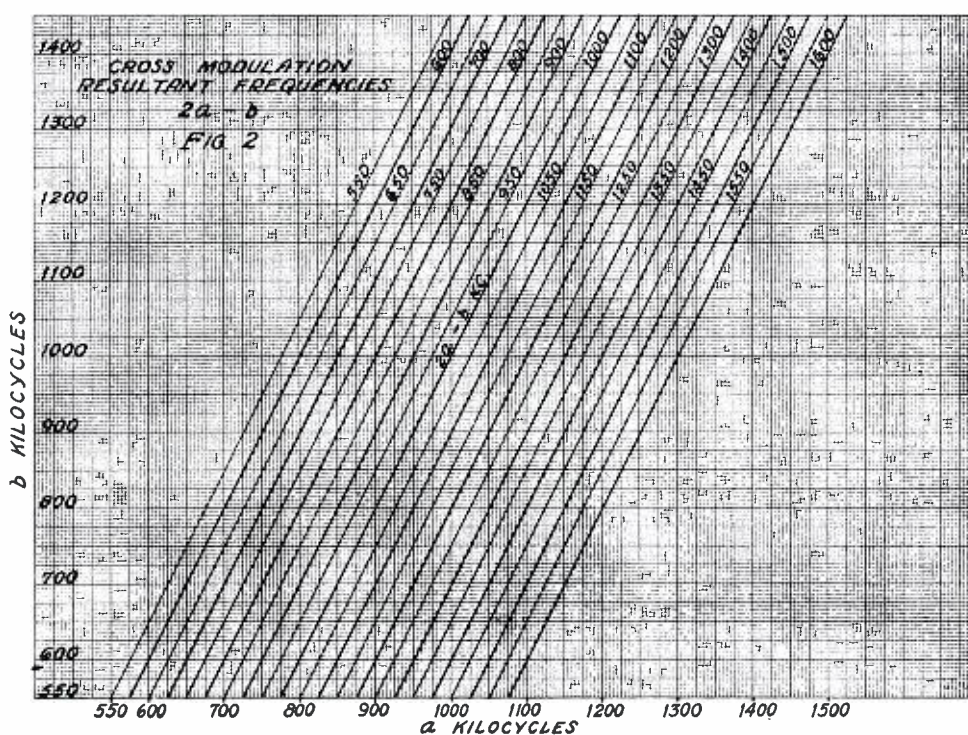

BUFFALO STATION

Modernization of Loc

By KARL B. HOFFMANN

THE Buffalo Broadcasting Corporation is justly proud of placing in operation a modern transmitting plant located on Sweet Home Road, 10 miles from Buffalo's business center.

The new building houses Stations WGR and WKBW, both operating at a power of five KW and feeding into a new 400 foot vertical antenna. The construction of the building is of reinforced concrete, making it entirely fire-proof. The exterior is composed of cream colored stucco and brick with green trim, and all windows are equipped with copper screens. The interior is decorated in light gray with black trim, and the equipment in the operating rooms is trimmed with stainless steel. A three-foot attic space and cork insulated roof is provided in order to obtain a cooler temperature in the building during the summer. Because of its proximity to Ellicott Creek, which frequently overflows its banks, a waterproof foundation was constructed raising the main floor five feet above the highest known flood level.

Space Divided

The building is evenly divided, with WGR on the right and WKBW on the left as one enters, each station having an operating, transmitter and power room. The operating rooms are separated by



Studio Master Control Room with the author at the telephone.

large double plate glass windows. Located in the operating rooms are the audio and monitoring equipment and transmitter controls. Overhead is located a large baffle containing an especially designed monitoring speaker.

The WKBW transmitter room contains the 5KW transmitter and an exhaust fan to carry the heat of the tubes outside, and in the power room are the motor generators and water cooling equipment.

The WGR transmitter room is equipped with the latest type 5 KW RCA transmitter, the power room containing transformers, induction regulator and water cooling equipment.

Cooling System

An additional feature is the use of both transmitter water cooling units to help cool the building in summer as well as to assist in heating it in winter. During hot weather the outside air is drawn into the operating, transmitter and power rooms, through especially provided openings in the floors to the cellar and thence to the attic and outside again, via the fan ducts. This rapid circulation of air reduces the temperature in the rooms considerably. During cold weather, by changing openings in the fan ducts, the hot air is circulated from attic to cellar in a closed system, thus materially aiding in the heating of the building.

All wiring and copper water piping is easily accessible from the waterproof cellar. Power panels, meters, telephone line termi-

Below: WGR Operating Room with the RCA 5KW transmitter on the right.



INCREASES POWER

Stations Brings Results

N. Technical Director



Left: Studio booth equipment.

(Continued on Page 25)

nations, automatic sump pumps and two General Electric Oil Burners are located here. The oil burners supply steam heat during the winter and hot water the year around.

Across the back of the building are the operator's living quarters, which consist of two bedrooms, shower and lavatory, kitchenette (with electric range, water cooler and refrigerator), lounge, workshop and office of the transmitter plant supervisor.

In the rear of the building is a two car garage and outdoor power transformer bank enclosed by a steel frame.

Ground System

The vertical antenna has a most extensive ground system, consisting of 1600 square feet of 6 inch copper strip in the form of a grid centered under the antenna, with 7 foot copper weld ground rods driven in at 10 foot intervals all around the outside edge. From this radiate 180 copper wire radials spaced 2 degrees apart, ex-

tending out like spokes in a wheel to form a circle 800 feet in diameter, all buried to an average depth of 6 inches. The building construction forms a part of the ground system in that all steel reinforcing, metal work and transmitter equipment is bonded to six inch copper strips which criss-cross in the form of a grid through the cellar and first floors, ceiling and roof. All of the copper strips are extended to the outside and connected to a six inch copper strip, running completely around the building, with 7 foot copper weld ground rods driven at 10 foot intervals. The copper wire radials that extend to the building are all connected to the copper strip running around it and are continued on from the opposite side. At the end of each radial a 7 foot copper-weld ground rod is driven, thus completing a ground system of 503,000 square feet.

Below: WKBW-WGR transmitter house and tower.

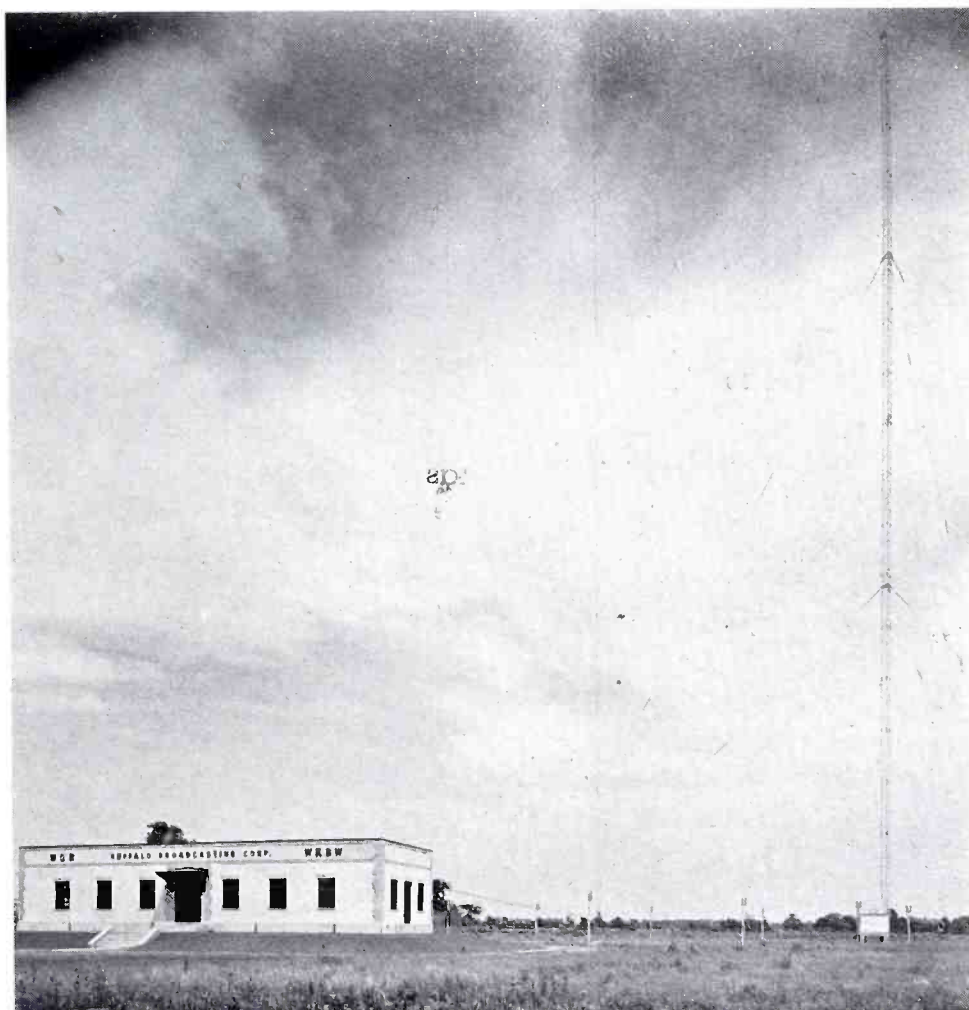

DIRECTIONAL ANTENNAS

A Development of Analytical Methods Applicable to General Problems in Array Design

DR. G. H. BROWN

Reprinted through the courtesy of Proceedings of the I. R. E.

IV. Two Driven Antennas

First we shall examine the case of two driven antennas.

The term "driven antennas" will be used to apply to antennas so fed by transmission lines that any current ratio and phase relation between the various antenna currents may be obtained.

The antennas are spaced a distance, d . In the arrangement of Fig. 10, the point, P , at which we shall calculate the field intensity, is so far from the antennas, 0 and 1, that $r_1 \gg d$, $r_0 \gg d$.

$$r_1 \doteq r_0 + d \cos \psi. \quad (19)$$

The projection of r_1 on the X axis is $r_1 \cos \psi$. The same projection is also $r_0 \sin \theta \cos \phi$, so that $\cos \psi = \sin \theta \cos \phi$.

Then,

$$r_1 \doteq r_0 + d \sin \theta \cos \phi. \quad (20)$$

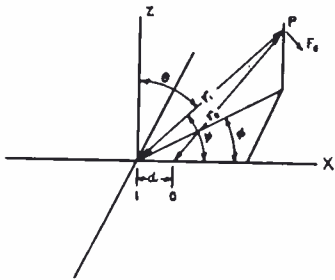

Fig. 10

The electric intensity at P due to antenna 0 is

$$(F_\theta)_0 = j \frac{60I_0}{r_0} \epsilon^{-j2\pi r_0/\lambda} K_0 f_0(\theta) \quad (21)$$

where K is the form factor of the antenna and $f(\theta)$ is the vertical radiation characteristic.⁸

The electric intensity at the same point due to antenna 1 is

$$(F_\theta)_1 = j \frac{60I_1}{r_1} \epsilon^{-j2\pi r_1/\lambda} K_1 f_1(\theta). \quad (22)$$

Since $1/r_1 \doteq 1/r_0$, the total field is

$$F_\theta = j \frac{60\epsilon^{-j2\pi r_0/\lambda}}{r_0} [I_0 K_0 f_0(\theta) + I_1 K_1 f_1(\theta) \epsilon^{-j(2\pi d/\lambda) \sin \theta \cos \phi}]. \quad (23)$$

When the currents are related by the relation

$$I_1 = MI_0 \angle + \alpha \quad (24)$$

the total field becomes

$$F_\theta = j \frac{60I_0}{r_0} K_0 f_0(\theta) \epsilon^{-j2\pi r_0/\lambda} \left[1 + \frac{MK_1 f_1(\theta)}{K_0 f_0(\theta)} \angle \alpha - \frac{2\pi d}{\lambda} \sin \theta \cos \phi \right] \quad (25)$$

When the antennas are identical,

$$F_\theta = j \frac{60I_0}{r_0} K f(\theta) \epsilon^{-j2\pi r_0/\lambda} \left[1 + M \angle \alpha - \frac{2\pi d}{\lambda} \sin \theta \cos \phi \right]. \quad (26)$$

Let us turn for the moment to the circuit relations at the antennas themselves. Kirchoff's law for the two circuits becomes

$$\bar{V}_0 = I_0 \bar{Z}_{00} + I_1 \bar{Z}_{01} \quad (27)$$

$$\bar{V}_1 = I_0 \bar{Z}_{10} + I_1 \bar{Z}_{11} \quad (28)$$

where,

$$\begin{aligned} \bar{Z}_{00} &= R_{00} + jX_{00} \\ &= \text{self-impedance of antenna 0.} \end{aligned}$$

$$\begin{aligned} Z_{11} &= R_{11} + jX_{11} \\ &= \text{self-impedance of antenna 1.} \end{aligned}$$

V = driving voltage at the terminals of the antenna.

Then,

$$\begin{aligned} \bar{V}_0 &= I_0 [R_{00} + jX_{00} \\ &+ M |Z_m| \angle \alpha + \theta_m] \end{aligned} \quad (29)$$

and,

$$\begin{aligned} \bar{V}_1 &= I_1 \left[R_{11} + jX_{11} \right. \\ &\left. + \frac{1}{M} |Z_m| \angle -\alpha + \theta_m \right] \end{aligned} \quad (30)$$

Expanding, we obtain

$$\begin{aligned} \bar{V}_0/I_0 &= R_{00} + M |Z_m| \cos(\alpha + \theta_m) \\ &+ j \{ X_{00} + M |Z_m| \sin(\alpha + \theta_m) \} \end{aligned} \quad (31)$$

and,

$$\begin{aligned} \bar{V}_1/I_1 &= R_{11} + \frac{1}{M} |Z_m| \cos(-\alpha \\ &+ \theta_m) + j \left\{ X_{11} + \frac{1}{M} |Z_m| \sin \right. \\ &\left. (-\alpha + \theta_m) \right\}. \end{aligned} \quad (32)$$

Equations (31) and (32) show quantitatively the change in resistance and reactance of an antenna when another element is brought into operation. These relations are of importance in designing antenna coupling circuits for directional arrays.

When the array is in operation, with the currents obeying the relation

$$I_1 = MI_0 \angle + \alpha$$

the resistance at the terminals of antenna 0 will no longer be R_{00} but will assume the value

$$R_0 = R_{00} + M |Z_m| \cos(\alpha + \theta_m) \quad (33)$$

while the resistance at the terminals of antenna 1 becomes

$$R_1 = R_{11} + \frac{1}{M} |Z_m| \cos(-\alpha + \theta_m). \quad (34)$$

⁸G. H. Brown, "A critical study of the characteristics of broadcast antennas as affected by antenna current distribution," Proc. I.R.E., vol. 24, p. 49, equations (2) and (3); January, 1936.

Thus, the values R_0 and R_1 will only be equal when $M = 1$, and then only when $\alpha = 0$ or 180 degrees.

Fig. 11 shows the variation of R_0 as a function of the phase angle, α , for a number of antenna spacings. These values are for the special case where $M = 1$ and $G = 90$ degrees.

Fig. 12 shows a similar curve for R_1 .

The new reactance of each antenna is

$$X_0 = X_{00} + M |Z_m| \sin(\alpha + \theta_m) \tag{35}$$

and,

$$X_1 = X_{11} + \frac{1}{M} |Z_m| \sin(-\alpha + \theta_m). \tag{36}$$

Figs. 13 and 14 show the quantities,

$X_0 - X_{00}$ and $X_1 - X_{11}$ for $M = 1$ and $G = 90$ degrees.

Figs. 11 to 14 may be utilized to determine the values when $M \neq 1$ from the following relations

$$(R_0)_M = M[(R_0)_{M=1} - R_{00}] + R_{00} \tag{37}$$

$$(X_0)_M = M \cdot (X_0 - X_{00})_{M=1} + X_{00} \tag{38}$$

$$(R_1)_M = \frac{1}{M} [(R_1)_{M=1} - R_{11}] + R_{11} \tag{39}$$

$$(X_1)_M = \frac{1}{M} \cdot (X_1 - X_{11})_{M=1} + X_{11}. \tag{40}$$

The power delivered to antenna 0 is

$$P_0 = I_0^2 R_0 = I_0^2 [R_{00} + M |Z_m| \cos(\alpha + \theta_m)] \tag{41}$$

while,

$$P_1 = I_1^2 R_1 = I_1^2 \left[R_{11} + \frac{1}{M} |Z_m| \cos(-\alpha + \theta_m) \right]. \tag{42}$$

(Continued on page 26)

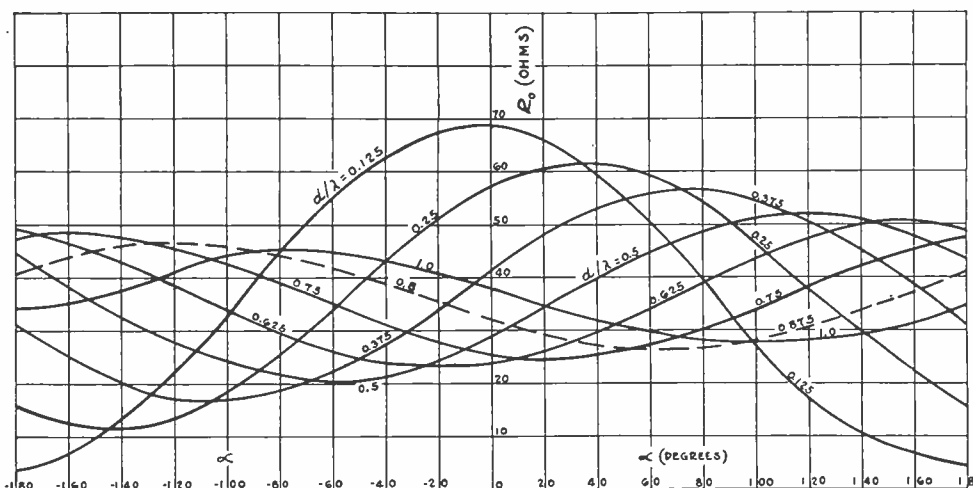

Fig. 11

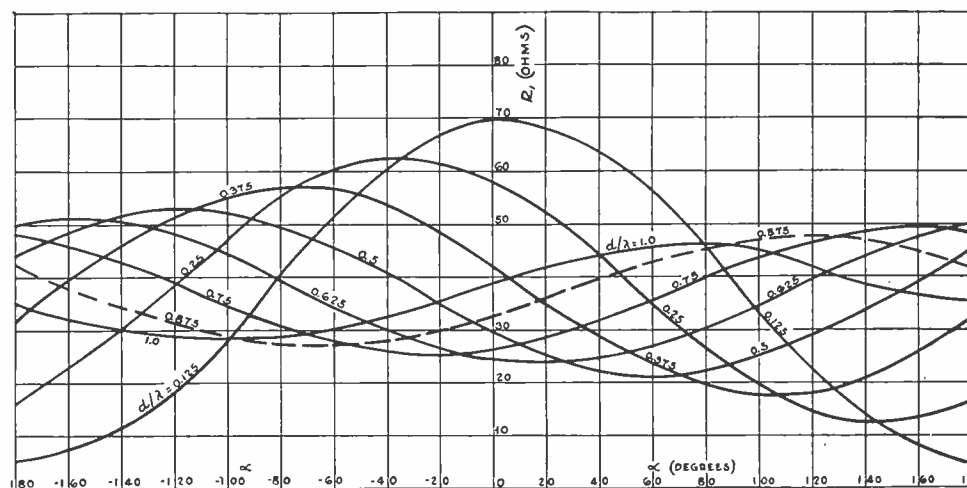

Fig. 12

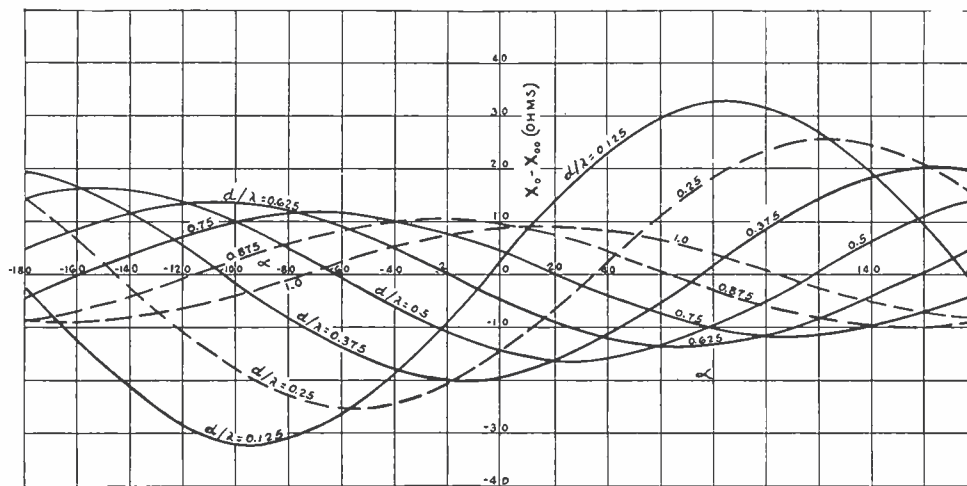

Fig. 13

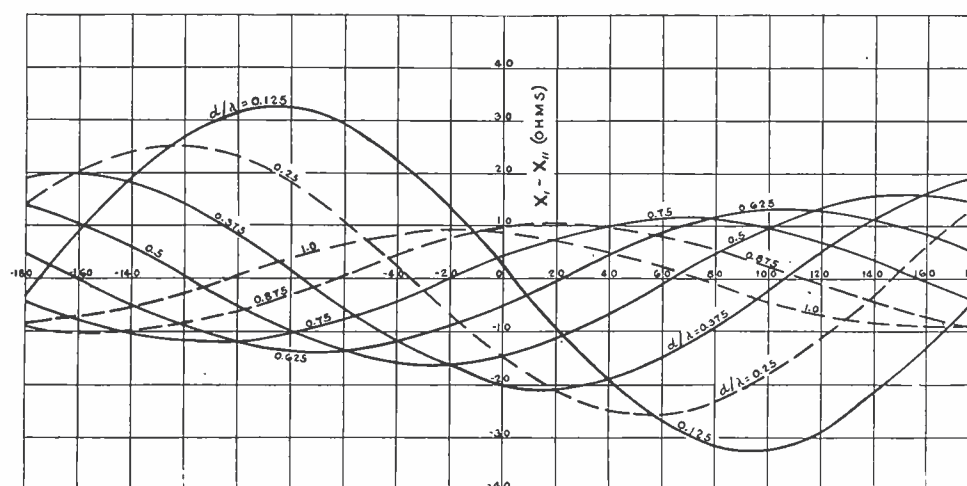

Fig. 14

WIDER COVERAGE FOR WFBM

Indianapolis Station Gains Greater Audience

By M. R. WILLIAMS

UNDER the management of R. E. Blossom and the technical direction of M. R. Williams, WFBM, Indianapolis, has effected a complete modernization program. New studios and offices, overlooking Monument Circle have been equipped in the most modern manner. Three new acoustically-treated, sound-proofed and air-conditioned studios comprise the local facilities. Each studio has its independent RCA high fidelity amplifying and monitoring equipment. Velocity mikes are used exclusively. The six channel Master Control board consists of the above, plus standard RCA test equipment used for proper maintenance of high quality reproduction. Each studio is equipped with individual control desks on which are mounted RCA automatic studio control systems. From this point the studio engineer supervises the program in progress. With this equipment it is possible to originate three programs simultaneously.

Ample Space

The transmitting plant is located on a 30-acre tract northeast of

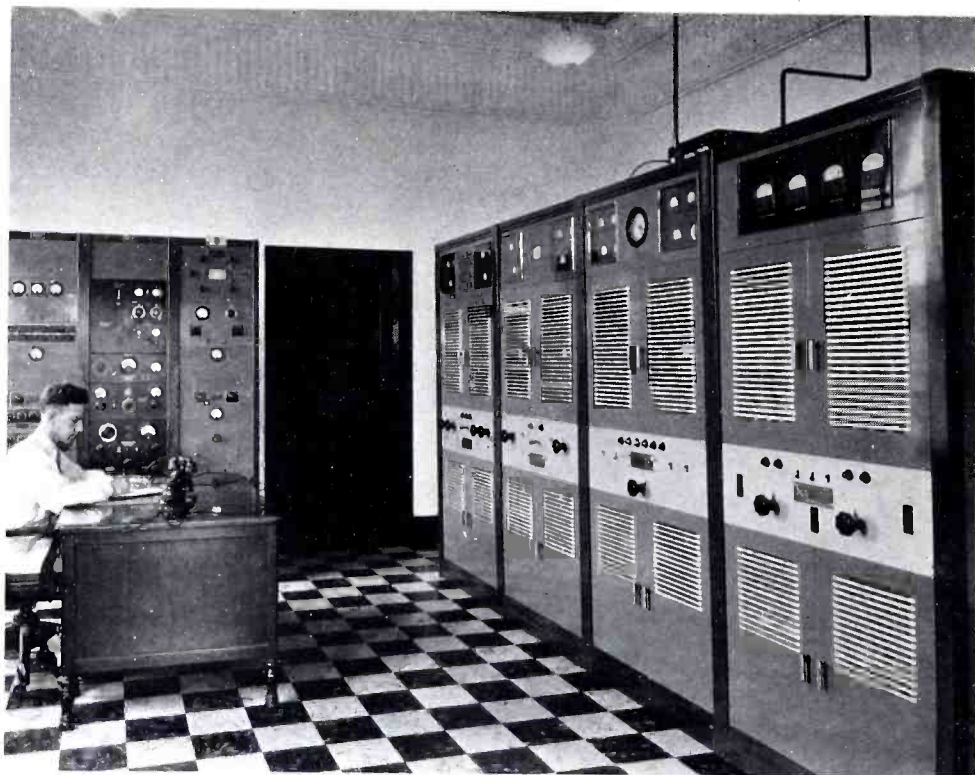

The RCA Type 5-C-1 Transmitter in operation at WFBM.

the city of Indianapolis. The building, constructed along conservative architectural lines, employs brick with Indiana limestone, and houses the high fidelity RCA transmitter and associated equipment.

Entrance to six of the eight rooms or the garage is made from the

main transmitter room. The walls throughout the building are painted cream with the wood-work finished in walnut. Acoustic tile is used for the ceiling of the transmitter room. The combination laboratory and office is built of heavy gauge steel electrically welded, and heavy screens at the windows give a perfect interference free "work-shop." Heat is supplied from a hot-water automatic oil furnace, with an air compressor and a water supply system also in the furnace room. Two power lines terminate in the transformer room, thus insuring WFBM against power-failure. In this room also are: transformer, voltage regulator, contactors, water cooling system and facilities for distilling water. The shop is equipped completely with jig saw, drill press, lathe and all necessary tools.

Method of Power Change

WFBM was the first station to employ the consolidated 5-C-1



The compact and efficient plant which houses the transmitter.

type transmitters. The unique method of power change employed to change from 1kw to 5kw, or vice versa, is made by the manual throwing of one switch, approximately 40 relays operating in the proper sequence, thereby changing the excitation, modulation, interlocks, antenna, plate voltage, and etc. With this arrangement as nearly automatic as possible a shift is made with no apparent interruption of broadcast. In effect giving two transmitters with the exception of the low power exciter unit.

Another outstanding feature incorporated in this respect is that on the first overload of the 5-C amplifier a relay is tripped causing the filaments of the 1-D to light. On the 3rd successive overload all associated relays operate, removing the 5-C amplifier and automatically placing the 1-D service in a fractional part of a second. A trench accessible at vantage points running beneath the speech input, test equipment racks and

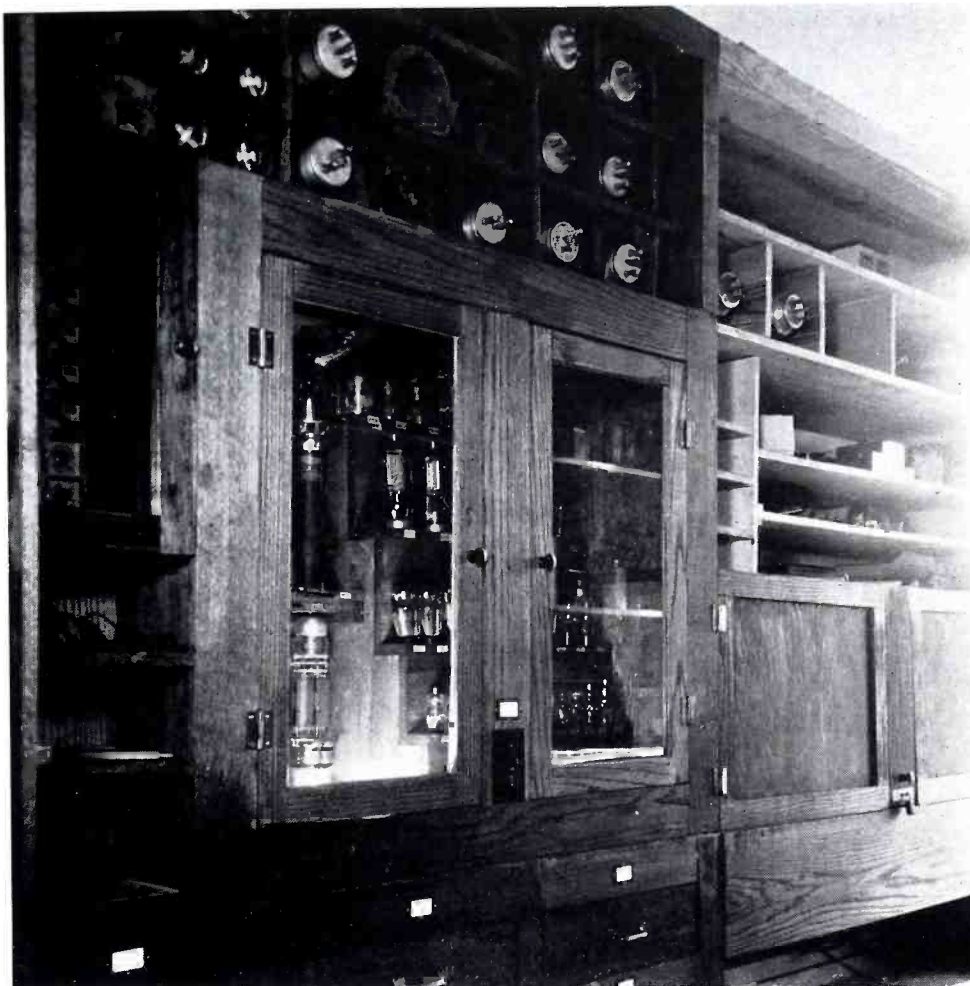

A convenient method of storing tubes.

main transmitter carry all the necessary wiring for interconnections. All of which is made in lead-covered wire. The frequency response of the RCA transmitter from 40-C amplifier to antenna is flat within 3db, from 30 to 17,000 cycles. With a harmonic distortion content of less than 4% at 100% modulation. Noise level has been adjusted to and measured as low as 67 db.

WFBM's antenna is an International Stacey 420 foot vertical radiator. The ground network consists of a 45 foot screen located immediately at the base of the tower from which 120 radials extend 500 feet, buried at a depth of 8 to 12 inches. Tower illumination is accomplished by an Austin Tower Lighting Transformer. The 5-inch space between the primary and secondary wirings offers ample insulation to radio frequency.

Many satisfactory reports on reception have been considered most gratifying by the station's management since extensive modernization plans have been completed.

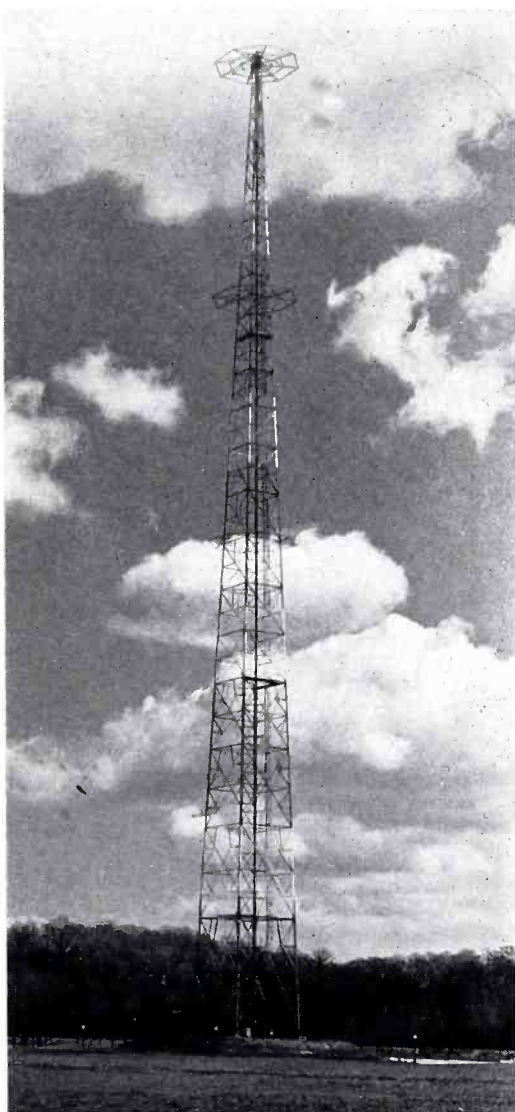

Antenna at WFBM

OHIO STATE UNIVERSITY TO BEGIN COURSE FOR BROADCAST STATION ENGINEERS

Ohio State University announces a course designed primarily for broadcast station engineers to be given February 7th to 19th, 1938. Tentatively, the course plans to cover antenna design, high power amplifiers, modulation and distortion measurements and studio acoustics.

This tentative schedule is of course, subject to change. Subjects may be added in response to demands but since it will require intensive work the topics will necessarily be limited.

The course will be conducted by members of the University staff with the assistance of outside lecturers who are recognized authorities on individual subjects. A small tuition charge will be made and for further information we suggest that those interested write to Professor W. L. Everitt, Ohio State University, Columbus, Ohio. A supplementary description of the course will be given in the next issue of Broadcast News.

GOING PLACES IN DIXIE

(Continued from Page 8)

and overhead transoms directly above the transmitter.

The transmitter is a new RCA type 250-D, and it certainly has met with ease the high standards of fidelity and efficiency set by the RCA company. A few of its outstanding features include the following: Two crystal oscillators, either one of which may be employed by throwing a two-way switch. Push-pull circuits are used in each of the three audio stages of amplification. High level plate modulation with a corresponding increase in efficiency is employed. The ability to shift from 250 watts to 100 watts of power for night operation by merely throwing a switch appeals especially to the operator. Finally the low cost of replacement parts, for example a complete set of tubes costs only about \$150, insures a low up-keep expense. The auxiliary equipment is also 100% RCA throughout. This consists of a modulation meter unit, a type 40-C RCA amplifier and attenuator unit, and a tri-amplifier for local microphone circuits.

The concentric feed-line from the transmitter to the antenna tuning unit is 68 feet long and contains nitrogen gas under a gauge pressure of 35 pounds per square inch. The terminating impedance of this line exactly matches that of the antenna itself (measured at 1500 kc). The nitrogen gas insures that

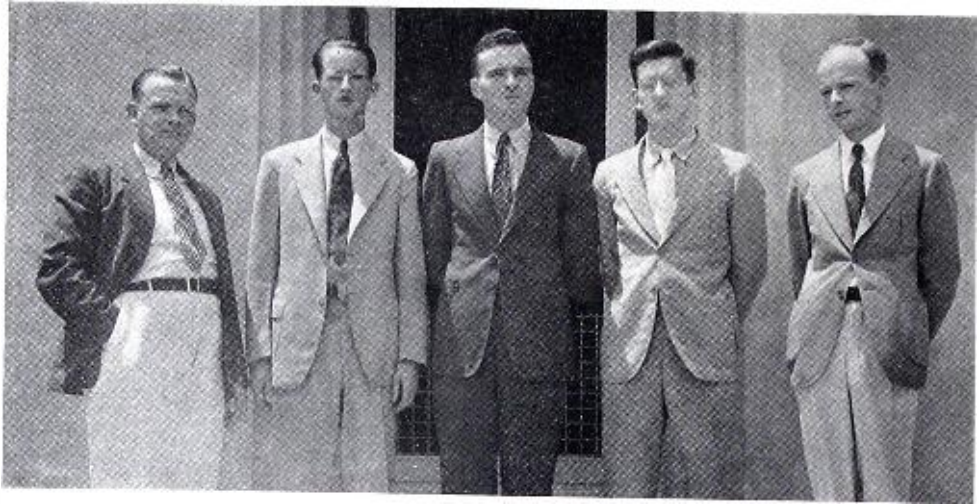

The Station Manager and Engineering Staff of greater WRDW. From left to right: Mr. J. Ed. Reynolds, Station Manager; Mr. Harvey J. Aderhold, Chief Engineer; Mr. T. Manson Manley, Engineer; Mr. Herbert G. Eidson, Engineer; Mr. Joseph L. Talley, Engineer.

the feed-line constants will remain the same regardless of weather or climatic conditions.

The modern vertical antenna is 179 feet high and has seven miles of copper wire buried at its base. This ground wire system lies six inches under the surface of the earth and radiates like spokes of a wheel. The converging ends of the wires are soldered to a copper sheet directly beneath the antenna.

Large Staff

It is unusual for a 250 watt station to have a personnel of fifteen employees, including a technical staff of five engineers. Under the able direction of our new station manager, Mr. Ed. Reynolds, WRDW is operating on a high plane in keeping with the progressive community that it serves.

Harvey Aderhold, chief engineer, demonstrates to Ed. Reynolds, the station manager, the new RCA transmitter during its initial broadcast.

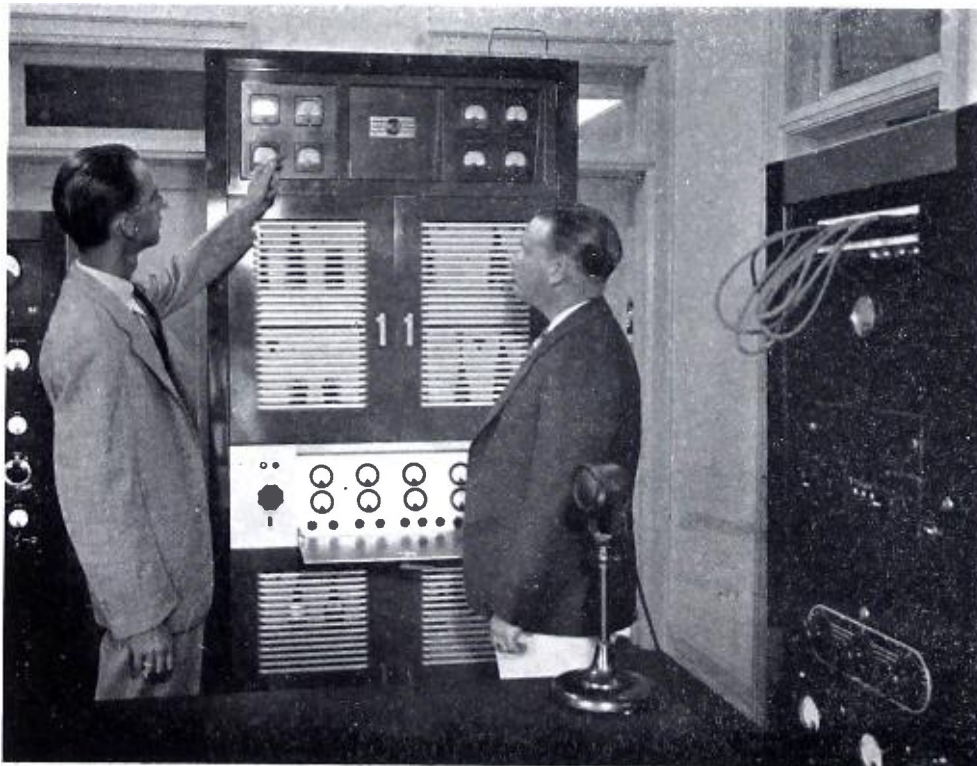

STREAMLINED CONVENIENCE

(Continued from Page 7)

The indicator point is more efficient than on previous knobs of this type because the line from center of top of knob extends to the point of marking in a fin-like shape without a gap between. In general, speaking of the efficiency of these knobs, besides the above mentioned features, no injury can be sustained by accidental contact and, at the same time, in case the lights should go out, it is possible to tune in total darkness, as the hands feel the web-like point rapidly. But its greatest service rests on the fact that it eliminates the fatigue and discomfort of the operator during the many hours that this knob is in use. And again, aside from its extreme consistency of functionalism, a beautiful form was evolved.

Tests

It was gratifying when all this work was completed and one of the severest tests ever given by a survey, to really find out how close we were in arriving at the perfect solution of this problem. A group of radio engineers, representative of those using the type of apparatus to which these knobs are applied, were given five unidentified types of knobs for this critical test, among which, was the knob under discussion. This survey resulted in a 73% preference for this knob over competing knobs, which was an amazingly high acceptance in introducing a new form where fixed ideas were established by reason of habit.

(Continued on Page 28)

BUFFALO STATION INCREASES POWER

(Continued from Page 19)

The antenna is a Truscon, 400 feet high, guyed uniform cross section welded steel tower, with a maximum cross section of 40 inches, supported by a Westinghouse insulator. A 1000 watt flashing red beacon is mounted on top with two 100 watt red lights mounted at the one-third and two-third levels and the tower is painted in accordance with the Department of Commerce Air Regulations.

Measurements made with a General Radio Bridge, show that this antenna operates at WGR'S frequency of 550 KC as a quarter wave with zero reactance and a radiation resistance of 34 ohms; at WKBW's frequency of 1480 KC as a .6 antenna with negative reactance of 91 ohms and radiation resistance of 43.5 ohms.

Measurements made with an RCA Field Strength TMV 75-B meter show an irregular circular pattern varying for station WGR from 480 to 420 millivolts per meter, and for WKBW from 460 to 410 millivolts per meter for 5 KW at one mile.

Tuning House

Six feet from the base of the antenna is located a fireproof reinforced concrete tuning house. The outside is similar in appearance to the main building and the inside is lined with copper screening. All steel reinforcing, metal work and equipment is bonded to 6 inch copper strips which in turn are bonded to the antenna ground system.

The tuning house contains two networks to match the transmission line impedance to the antenna, two filter networks to prevent power on one transmission line from feeding into the other and two tower lighting chokes to prevent the radio frequency from feeding into the commercial lighting circuits. The output of the filter networks and tower lighting chokes combine and are connected to the antenna by a copper tubing carrying the lighting wires inside. A two turn choke coil and

lightning gap at the tower end provide some degree of lightning protection. There are also two rectifier units that operate auxiliary antenna ammeters and monitoring loud speakers in the operating rooms in the main building.

Connecting the tuning house with the output of the transmitters in the main building are 2 four wire transmission lines supported on Lapp Insulators (mounted on wooden poles 15 feet in height) balanced to ground and having a resistance of 315 ohms. The construction of these lines is such that at no point do they parallel, and they approach the tuning house at right angles. This was done to hold cross talk to an absolute minimum.

Improvement in Operation

Already during the short time in which this plant has been in use, it has proved not only the effectiveness of two-station operation into a single antenna but also the fact that it is the most economical. The cross talk holds to a minimum of 60 DB which is equivalent to the transmitter carrier noise level, and the power loss is negligible. Listener's reports and technical measurements show that a vast improvement in coverage and signal strength has been made.

The studios of the Buffalo Broadcasting Corporation are on the 18th floor of the Rand Building located in the center of the business district of Buffalo, N. Y.

The Master Control room and studios booths are completely equipped with RCA amplifiers and the five studios all use velocity microphones. Each studio and booth is a complete unit by itself, containing pre-amplifiers for each microphone, mixers, program and monitoring amplifiers, transcription equipment, and talk back system with the microphones controlled by low level relays. The entire system is interlocked to prevent placing of two programs on the same station. Studio relay controls are duplicated in the operator's booths and master control room so that any switching errors may be immediately corrected.

The remote pick-up department uses the latest type RCA equipment. An especially designed and constructed 25 watt ultra high frequency transmitter mounted on a truck together with several pack transmitters and receivers is used for many unusual broadcasts.

SPACE BECOMES A FACTOR

(Continued from Page 11)

A jack is provided on the right-hand front panel for head phone monitoring across the output of the studio amplifier. Also located on this panel are the power "off-on" switch, the power "on" indicating light, the talk-back and monitor transfer key switches, and the plate current and VI Meter switches. The left-hand panel mounts the two jack strips, the line input key switches, and the monitor volume control. The monitoring amplifier is located in the left-hand section of the cabinet, the preamplifier in the center and the studio amplifier in the right hand section.

The preamplifier chassis is hinged at the back to swing open for convenient servicing. The monitoring and studio amplifier chassis are readily serviced through openings in the bottom of the console or they can be completely removed. All external wiring is brought in through an opening in the back of the cabinet and terminates on a standard terminal board.

The electrical specifications of the 76-A Console fulfill the requirements of high-fidelity broadcasting in every respect. The overall noise and hum level (at normal program settings) is -57 db. The overall frequency response is within plus or minus 1 db. from 30 to 10,000 cycles. These together with the low distortion (1% RMS at 400 cycles) leave little to be desired. Thus the 76-A Console incorporates a complete, self-contained one and two studio speech input system with a novel and flexible control system, housed in an attractive cabinet, completely factory wired and tested and designed to be used with high quality microphones for economical, high-fidelity broadcasting.

DIRECTIONAL ANTENNAS

(Continued from Page 21)

The total power is

$$P_T = I_0^2 [R_{00} + M |Z_m| \cos(\alpha + \theta_m) + M^2 \frac{1}{M} R_{11} + \frac{1}{M} |Z_m| \cos(-\alpha + \theta_m)]$$

$$= I_0^2 [R_{00} + M^2 R_{11} + 2MR_m \cos \alpha]. \quad (43)$$

Thus, for a given power input to the antenna array, (43) gives a convenient method of evaluating I_0 .

The magnitude of I_1 is $M \cdot I_0$.

We are now prepared to return to the field intensity relations. In particular, let us examine the case of two identical antennas, with equal self-resistances.

For a given input power

$$F_\theta = j \frac{60Kj(\theta)}{r_0} \epsilon^{-jkr_0} \frac{[1 + M \angle \alpha - kd \sin \theta \cos \phi] \sqrt{P}}{\sqrt{R_{00}(1 + M^2) + 2MR_m \cos \alpha}} \quad (44)$$

When $\theta = 90$ degrees

$$F_{\theta=90^\circ} = j \frac{60K}{r_0} \epsilon^{-jkr_0} \frac{[1 + M \angle \alpha - kd \cos \phi] \sqrt{P}}{\sqrt{R_{00}(1 + M^2) + 2MR_m \cos \alpha}} \quad (45)$$

This relation gives the distribution in the horizontal plane (as a function of ϕ). If a single antenna were fed with the same power, the field on the horizontal plane would be

$$F_0 = j \frac{60K}{r_0} \epsilon^{-jkr_0} \sqrt{\frac{P}{R_{00}}} \quad (46)$$

It is then convenient to express the horizontal field intensity distribution in terms of the field intensity of a single antenna

$$\frac{F_{\theta=90^\circ}}{F_0} = \frac{\sqrt{R_{00}} [1 + M \angle \alpha - kd \cos \phi]}{\sqrt{R_{00}(1 + M^2) + 2MR_m \cos \alpha}} \quad (47)$$

or,

$$\frac{F_{\theta=90^\circ}}{F_0} = \frac{1 + M \angle \alpha - kd \cos \phi}{\sqrt{1 + M^2 + 2M \frac{R_m}{R_{00}} \cos \alpha}} \quad (48)$$

$$\left| \frac{F_{\theta=90^\circ}}{F_0} \right| = \frac{1 + M^2 + 2M \cos(\alpha - kd \cos \phi)}{1 + M^2 + 2M \frac{R_m}{R_{00}} \cos \alpha} \quad (49)$$

From our previous discussion, we learned that R_m/R_{00} was substantially independent of the antenna heights, provided both antennas remained equal in height. Thus, for a fixed current ratio and phase angle, we see that the gain of two similar antennas over one of these antennas is essentially independent of the antenna height.

When the currents become equal in magnitude, ($M = 1$)

$$\left| \frac{F_{\theta=90^\circ}}{F_0} \right| = \frac{\sqrt{2} \cos\left(\frac{\alpha}{2} - \frac{kd}{2} \cos \phi\right)}{\sqrt{1 + \frac{R_m}{R_{00}} \cos \alpha}} \quad (50)$$

The above equation as a function of ϕ , d/λ , and α is illustrated by Fig. 15* Diagrams similar to Fig. 15 have been published elsewhere.⁹ However, these diagrams have merely been plots of the factor,

$$\cos\left(\frac{\alpha}{2} - \frac{kd}{2} \cos \phi\right)$$

so that the effect of mutual coupling is not present.

* See following page.

⁹G. C. Southworth, "Certain factors affecting the gain of directive antennas," Proc. I.R.E., p. 1507, Fig. 3; September, (1930); A. James Ebel, "Directional radiation patterns," Electronics, vol. 9, p. 29; April, (1936).

Since it is difficult to scale values from Fig. 15, maximum values of (50) have been plotted in Fig. 16 as a function of α for a number of values of d/λ . We see it is possible to increase the field about 75 per cent with reasonable spacings between elements.

It is interesting to attempt to maximize (49) by adjusting M and α . Suppose we wish to maximize the field in the direction making an angle ϕ with the line of antennas.

Squaring (49)

$$\left| \frac{F_{\theta=90^\circ}}{F_0} \right|^2 = \frac{1 + M^2 + 2M \cos(\alpha - kd \cos \phi)}{1 + M^2 + 2M \frac{R_m}{R_{00}} \cos \alpha} \quad (51)$$

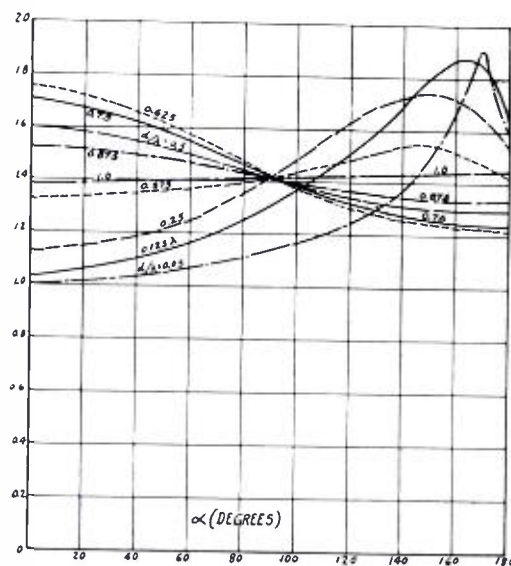

Fig. 16

The maximum increase in field intensity possible from an array of two antennas.

Differentiating with respect to M and setting equal to zero

$$\left[1 + M^2 + 2M \frac{R_m}{R_{00}} \cos \alpha \right] [2M + 2 \cos(\alpha - kd \cos \phi)] - [1 + M^2 + 2M \cos(\alpha - kd \cos \phi)] \left[2M + \frac{2R_m}{R_{00}} \cos \alpha \right] = 0 \quad (52)$$

or,

(Continued on Page 31)

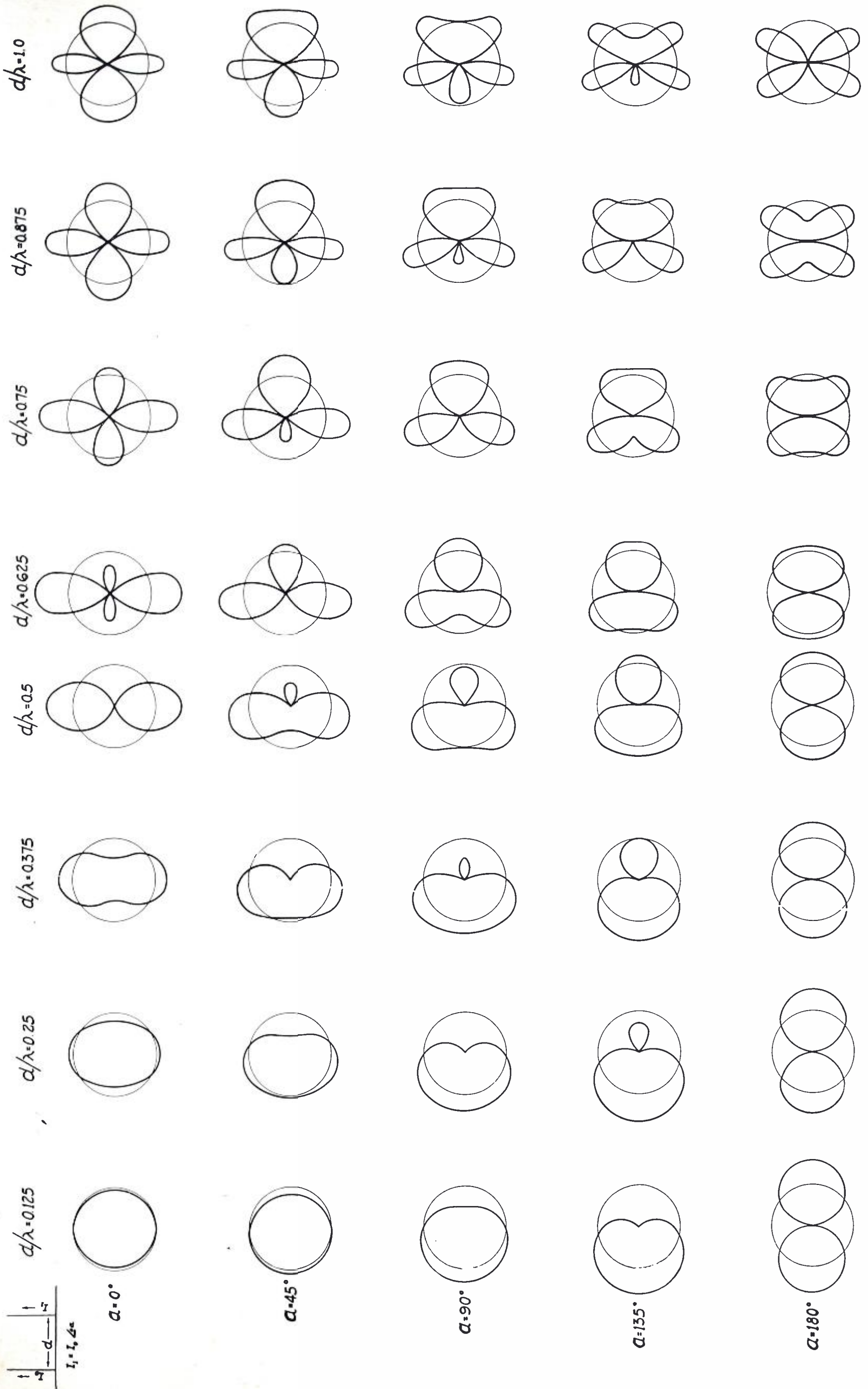

Fig. 15. Horizontal radiation patterns for an array of two antennas fed with equal magnitude currents.

LIGHTNING IS A MENACE

(Continued from Page 13)

It will be noted that beyond the horn gap between the lead-in insulator and the antenna tuning equipment an inductor of several turns of copper tubing is connected. The object of this inductor is to increase the effective impedance of the circuit to steep wave fronts such as are developed by lightning hits. The effect is to increase the speed of voltage build-up across the horn gap, and consequently, to break the gap down more rapidly than would otherwise be the case. An inductance of a microhenry or less is adequate for this purpose.

Effective Protection

To obtain effective protection it is vital that the horns of the gap be set as close together as possible. A one-eighth inch gap will not break down under a voltage stress of 5000 volts, and may be used for antenna powers up to 5 KW, carrier, with most conventional antennas.

A good rule to follow in adjusting the gap is to decrease the spacing until it just breaks down when the transmitter is modulated to its maximum capability. The gap should then be set to double this distance. Our experience has been that while horn gaps or tower base gaps are provided on the majority of antenna installations; the actual air gap is much too wide to provide protection to the equipment.

It is highly desirable to employ the same sort of protection on transmission lines to safeguard them from voltages introduced into the system by pick-up from the antenna, as well as to provide

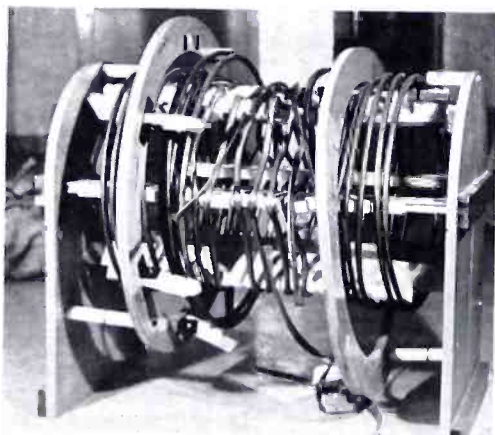

Photo: Courtesy J. H. DeWitt.

When lightning hit, the tank coil blew up but WSM was on the air again within two hours.

protection against direct hits on the line or high induced voltages. Concentric lines are particularly vulnerable, since an arc started inside the line by a static discharge may continue to burn until it has ruined the line. An equally dangerous effect is apparent when an arc starts somewhere along a concentric line completely upsetting the line termination. The resulting reflections may cause the line to break down at other points and may cause destructively high voltages to build up in the transmitter. Open-wire lines are not so vulnerable from this standpoint since the spacing between the wires is too great to permit an arc to maintain itself. However, open-wire lines should be protected to prevent the application of dangerously high voltages to connected equipment. If the transmission line is over 500 feet long, horn gaps should be provided at each end of the line. Static drain chokes should be used at one end.

It is often possible to arrange terminating circuits so that a metallic path is provided from antenna to ground and from transmission line to ground. Such circuits eliminate the necessity of providing static-drain chokes for the antenna or transmission line. They do not, however, obviate the necessity of providing protection against direct hits in the vicinity of the antenna. This protection can only be obtained by the use of correctly designed horn gaps. The installation of protective equipment of this sort will pay real dividends in reduction of time off the air, and in safeguarding valuable equipment.

IMPROVED SERVICE

(Continued from Page 6)

cities in Europe lie within a relatively narrow angle; whereas coverage over the greater part of South America requires antennas which have an appreciable gain over an angle of from 35 to 40 degrees. Non-directive and semi-directive antennas are also available for use when directivity is not required. Each of the antennas is fed by transmission lines which are matched and balanced. These lines are connected to a unique rotary switch which permits a rapid selection of any one of six antennas now available.

STREAMLINED CONVENIENCE

(Continued from Page 24)



The reasons given were as follows:

1. Large and easily gripped.
2. Rounded surface and natural feel.
3. Best for working two pots with one hand.
4. Pointer easy to find—not necessary to look at it. Can be held between second and third fingers.
5. Increased leverage. Can be worked with greater ease and gives finer adjustment.

The divisions that have assisted in this work should come in for their due credit. The particular contributing divisions to the development of this knob are the Photophone and Transmitter divisions.

The only other recent experience I had in working on a similar problem that appeared insignificant and yet very important when it came to solution was a stream-lined paring knife for Remington-Dupont. It was disclosed that one-third of the time spent in the kitchen a paring knife is in constant use, and at no time before was this object given any attention. Man's most valuable mechanism are his hands and it is only recently that any serious consideration was given in preserving and retaining their beauty and efficiency.

A more complete conception of the detail and romance behind the creation of our new giant transmitters and the care devoted to their details can readily be appreciated when it is realized from the foregoing account, the amount of infinite detail and investigation involved in the creation of a relative small unit such as the knob, merely one small component of a panel.

TWO MORE STATIONS EXPAND WIP AND WJDX IMPROVE FACILITIES



Benedict Gimbel, Jr., President of WIP, whose leadership has been instrumental in bringing this station to the front.



(Above). P. K. Lutken, President of the Lamar Life Insurance Company, Jackson, Miss., signing the contract for the 5-D Transmitter to be installed at WJDX.

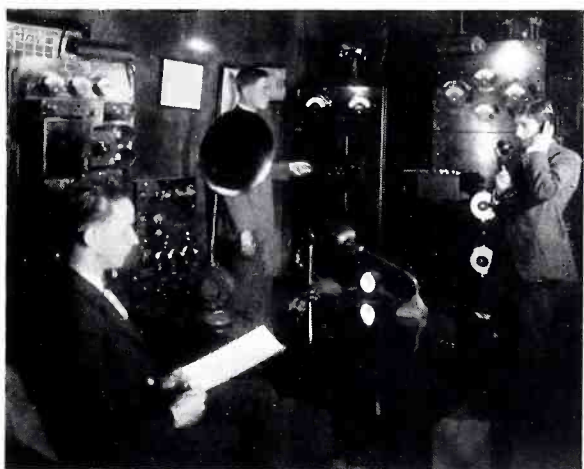

(Above). The control room at WIP as it looked in 1925. Compare it with the very modern layout pictured below.

(Below). The new control room at WIP which was placed in operation in August, 1937. WIP has recently installed a new 1-D Transmitter completely modernizing its plant.

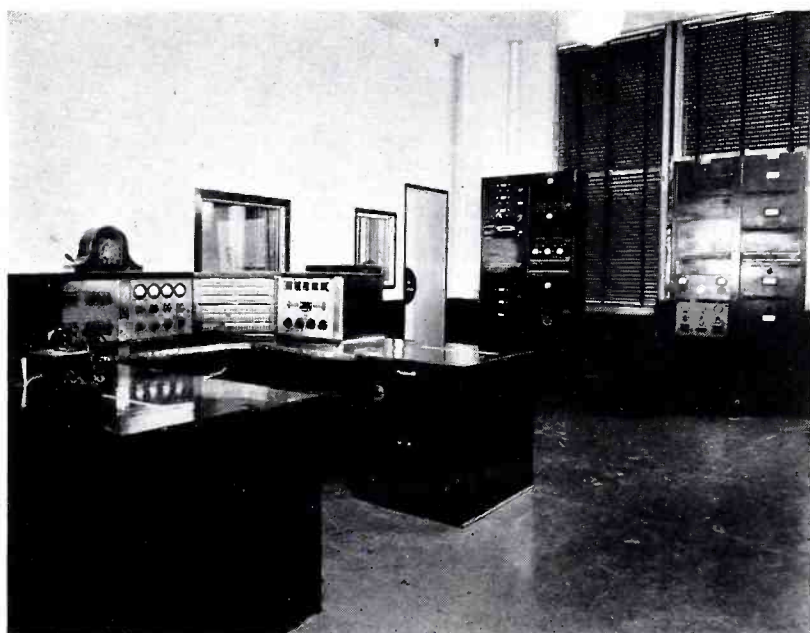

(Below). Not a fish story. Wiley Harris, Manager of WJDX explaining to P. K. Lutken some of the salient features of the new 5-D Transmitter.



BINDER AVAILABLE FOR BROADCAST NEWS

Many of our readers keep their copies of Broadcast News for future reference. To enable them to do this conveniently we have arranged with the manufacturers of the Gilmer Binder to design a special binder in dark blue, morocco grain fabrikoid, with gold stamped titles. This binder is made to contain 12 issues of Broadcast News. This is a simple and sturdy binder and will open perfectly flat for easy reference. It is priced at \$2.00 with a guarantee of money back if you are not more than satisfied. All orders should be sent direct to The Gilmer Binder, 228 Chancellor Street, Philadelphia, Pennsylvania.

MISTAKES ABOUT MARCONI

(Continued from Page 9)

device for putting out of commission automobiles or other devices of the sort, although it was well known to him, as to all other radio men, that such a device is possible today for short distance operation, and may in time be made to cover longer ranges. As a matter of fact, the creation of such a device would have been foreign to Marconi's personal desires, as he regretted that the inventive genius of the world was being employed for purposes of destruction.

There are many other "Marconi myths" extant, but the foregoing are the most persistent, and the farthest from fact.

NEW LIMITING AMPLIFIER

(Continued from Page 15)

2. Hinged chassis construction, which greatly facilitates routine examination of components and servicing operations.

3. Teardrop design, illuminated dial meter.

Further mechanical specifications of the amplifier and power supply are as follows:

1. Dimensions:

(a) Rack mounting panels—19" wide.

(b) Panel heights: amplifier—14"; power supply 10½".

(c) Chassis depths—9".

2. Weights (unpacked):

(a) Amplifier—41 lbs.

(b) Power supply—49 lbs.

3. Terminals: Screw type on strip at back of chassis.

COLUMBIA'S TELEVISION TRANSMITTER NEARING COMPLETION

First Tests Being Given New Equipment

THE Columbia Broadcasting System's new television transmitter construction of which required the work of some 50 technicians for a period of more than nine months, is being given its first power tests at the RCA Manufacturing Company, Camden, N. J., and probably will be ready for delivery to New York shortly after the first of the year.

When completed, the transmitter is to be shipped to New York for installation on the 73rd and 74th floors of the Chrysler Building. There it will provide television programs from the nearby Grand Central Station studios now being built by Columbia which may be picked up within a radius of approximately 40 miles over a total area of about 4,800 square miles of thickly populated territory.

Columbia's new transmitter really consists of two complete units almost identical in construction. One of these will be used to transmit high fidelity sound while the other produces pictures exactly synchronized with that sound. Only a slight difference in design is needed to perform these different functions despite the fact that the sound transmission will cover a frequency range of up to 10,000 cycles while the wave band needed to reproduce high frequency 441 line interlaced pictures extends to the tremendous total of 2,500,000 cycles.

Twenty-four water-cooled tubes, ranging in length from ten inches to around four feet, have been especially designed for use in the two transmitters. Each of the latter has a 7,500 watt output with a 30,000 watt peak modulation. Due to the fact that tremendous heat will be generated by the 400,000 watts of power consumed in producing this output, a complete air conditioning unit has been built to cool the 120 gallons of water per minute used to reduce the temperature of the vacuum tubes and other parts of the equipment. In

addition, 1,000 gallons of oil are needed to cool the ten gigantic transformers used.

Every safety precaution has been taken in designing Columbia's sensational new station. The steel structure of the Chrysler Building's floors is being strengthened to bear the additional weight. The control panel is equipped with lights which indicate failure of operation at any part of the equipment. A second series of controls and lamps is installed back of this panel so that in an emergency the transmitter can be controlled from there. And interlocking automatic circuits have been arranged so that power will be cut off and signal lamps lighted the instant anyone opens a door leading to the high tension wiring.

The 74th floor also contains a room where all input circuits from the adjacent Grand Central Station studios come in and another where power from the public utility company is introduced.

When all of this equipment is ready for installation, it will be necessary to construct special rigging to lift it from the 71st floor, where elevator service ends, to the floors above.

Experiments now are going on in Camden to determine the type of antenna best suited for the transmitter and also for the Chrysler pinnacle around which it is to be constructed. A complete "electrical reproduction" of the top floors of the skyscraper has been constructed on a baseball field used by employees of the manufacturing plant and different kinds of antennas are being built and tried out on this structure under conditions almost identical with those on the tower itself. The reproduction is built of wood and steel and covered with heavy wire netting. It looks so much like an oil well derrick that its construction almost started a petroleum boom among Camden residents.

HUMAN SIDE OF MARCONI

(Continued from Page 3)

and testing, just as I did. I have never lost touch with that side of my career, and never shall."

Some years later he again voiced the same opinion at the Century of Progress in Chicago. Two days had been designated as Marconi Days, and at the close of the strenuous schedule, he insisted on visiting an amateur station which had been set up in the Palace of Transportation. When the startled boys saw their visitor they forgot schedules and everything else, and showed him proudly around their exhibit. As he was about to leave, he noticed a partly built transmitter, and said "That is certainly a fine piece of work." "But, Mr. Marconi," said the lad, "it can't be very good, for I am only an amateur." "That may be so," replied the Senatore, "But remember, I am only an amateur myself."

Short Wave Communication

The Institute of Radio Engineers not only owes its existence to the art which Mr. Marconi founded, but also was honored from time to time with scientific contributions from him. One of these was delivered in person, in 1920, when Senatore Marconi was the recipient of the Medal of Honor of the Institute, at a joint meeting of the Institute of Radio Engineers and the American Institute of Electrical Engineers. This lecture was on the then new subject of shortwave

communication, and a beam transmitter on a turntable was demonstrated, showing how, with waves almost as short as one meter, the transmitter could be turned toward the receiver to give a signal, or turned a few degrees off, in which case nothing would be heard. This lecture was a history-making one in radio circles, and Mr. Marconi was asked why he gave it first to America instead of to London or Rome. "Because I feel under a deep sense of obligation to America," he replied. "When I was unknown, in 1901, I was received enthusiastically by American scientists, and they tendered me a most unexpected banquet when I received the first signals across the Atlantic. So today I am giving to America and its two great electrical societies the first information and the first demonstration of my new beam apparatus."

Marconi was also Honorary President of the Veteran Wireless Operators' Association, a group of old time radio operators and engineers. He always found time to send a long message of greeting to the annual meeting, and his letter of acceptance, when he had been made Honorary President, expressed his real pleasure in the appointment. In December, 1931, on the 30th anniversary of his first wireless conquest of the Atlantic, the VWOA presented him with a special gold medal, to which he replied "I am deeply touched at having been conferred such a generous token of appreciation by

the VWOA, the component members of which are particularly close to me, and I wish to assure you that your valuable gift will be treasured amongst the most cherished rewards I have ever received."

Monument Planned

There is a movement already under way, sponsored by the VWOA, to keep alive the memory of Veteran No. 1 by a suitable monument. The first subscription was from the Operators' Monument Fund, and the second, a donation of \$1000, was from RCA through its president, Mr. David Sarnoff, life member of the association.

The first wireless station built, under Mr. Marconi's direction, by the newly formed American Marconi Company was at Babylon, Long Island. It was a mere shack, and was used chiefly for experimental work. Years later, it was abandoned, and was forgotten until 1931, when Edwin H. Armstrong, of superheterodyne fame, rediscovered it, in use as a paint shop, and presented it to RCA. It now stands at the high power station in Port Jefferson, Long Island, and during the forthcoming World's Fair in New York it will be completely fitted up with replicas of the original transmitter and receiver used in 1901, and exhibited at the Fair as part of the RCA exhibit, as a memorial to Senatore Marconi.

DIRECTIONAL ANTENNAS

(Continued from Page 26)

$$M^2 \left[\frac{R_m}{R_{00}} \cos \alpha - \cos (\alpha - kd \cos \phi) \right] - \left[\frac{R_m}{R_{00}} \cos \alpha - \cos (\alpha - kd \cos \phi) \right] = 0. \tag{53}$$

Then $M^2 = 1$ and $M = \pm 1$.

Since we have used M merely as a ratio, with the angle α to indicate phase, we are interested only in the value $M = +1$. Thus we see that maximum fields are obtained when the currents are equal in magnitude. We could differentiate (51) to find the optimum phase angle. It is simpler to obtain this information from an inspection of Fig. 15.

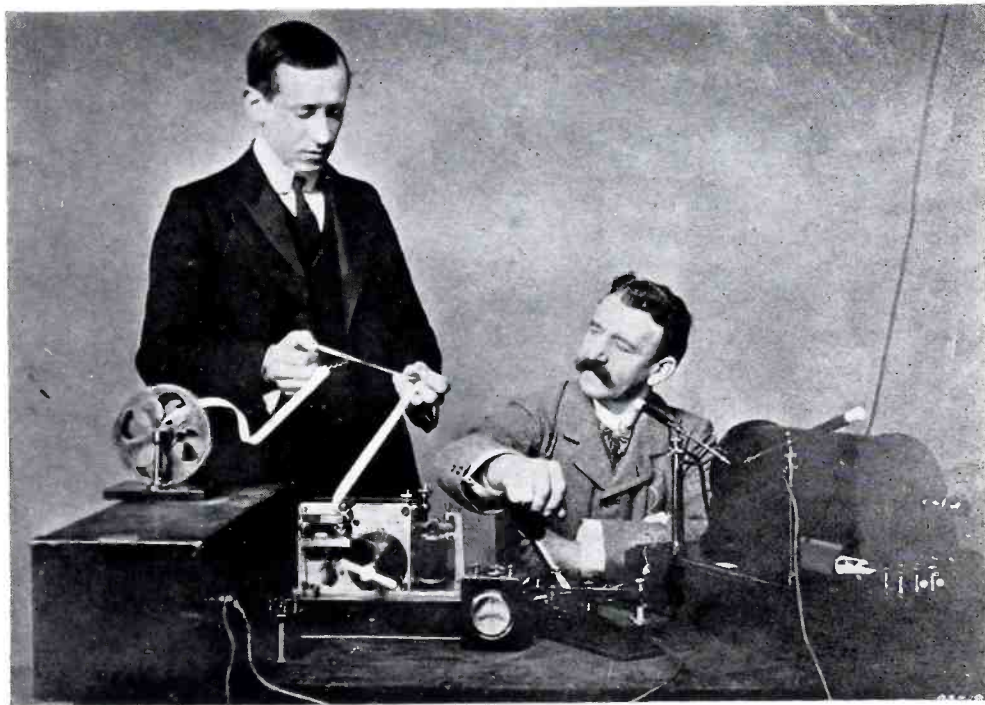

The youthful Marconi standing beside some of the equipment used in the early days of radio.

CROSS MODULATION

(Continued from Page 17)

stations having high field strength are known. The combinations $2a - b$ and $2b - a$ are usually in the broadcast band and for that reason are troublesome. Figure 2 is a chart for reading the spurious frequency $2a - b$ for any value of a and b . By reversing the designation of a and b the chart can be used for finding $2b - a$ also.

In investigating a situation where interference exists, the first step should be to determine whether or not it is due to external cross modulation by observing the frequencies at which interference exists. For example, with the two strong signals at 650 kc. and 750 kc., if the program from both is heard at 550 kc., 850 kc., and 1400 kc., it may be safely assumed that the trouble is due to external cross modulation. If the interference is not due to external cross modulation shortening the antenna or installation of a wave trap tuned to the interfering signal, or both, will remedy the situation.

Checks for Type

Cross modulation may, of course, be produced in the radio-frequency or first-detector stage of the receiver if the tubes are not of the remote cut-off or variable-mu type or if the operating bias is, for any reason, incorrect.¹ Cross modulation occurring in the receiver can be differentiated from that due to external causes by use of a short antenna, a wave trap tuned to the strongest interfering station, or by substituting another receiver. These expedients will eliminate, or greatly reduce, cross modulation which takes place in the receiver, but will not affect external cross modulation.

As seen from some of the cases, the rectifying element may be in the power wiring, piping, or in the antenna itself. Therefore, the first step in eliminating the trouble should be to make sure that the antenna and ground connections to the receiver have secure, tight joints throughout, soldered joints

in the antenna being preferable. If this does not cure the interference, the next step is to endeavor to find the rectifying element elsewhere. If the rectifier is in the power wiring, connection of two 0.1 μ f. condensers across the lighting lines, with the center point going as directly as possible to a good ground, should produce at least some decrease in the cross modulation. In this connection it should be remembered that steam or gas piping, and in some cases water piping, may have joints which are electrical rectifiers, and in this event use of such piping as a ground for the receiver will intensify cross modulation. The house should be examined for indications of pipes or electrical conduits which touch each other. If such points are found they should be separated by a block of wood or else bonded together securely.

Antenna Location

If the source of rectification cannot be located, it still is usually possible to secure interference-free reception by the proper type of antenna installation. The location for an antenna which is free from cross modulation can be readily found by the use of a portable battery receiver equipped with a short antenna. It will be found that the cross modulation occurs in the battery receiver when it is within the house, but disappears a few feet outside the house. By this exploration means, a location for the antenna is to be found where cross modulation does not exist. The spurious frequencies will, however, be picked up on the lead-in unless it is thoroughly shielded. In some cases metallic braid shielding may not be good enough and concentric transmission line cable, which is now available in small sizes must be used. Since the shielded cable is low in impedance, it is necessary to use matching transformers at the antenna and at the receiver to obtain maximum efficiency. If such transformers are used, they should be examined for possibility of poor connections which will cause rectification and resultant cross-modulation interference. It must be remembered also that the ground lead of the receiver is capable of picking up

radio-frequency energy so that it should be as short and direct as possible. The receiver should be re-located to accomplish this if necessary.

Resume

The steps involved in eliminating cross modulation interference are:

1. Calculate the frequency combination values to make sure the interference is cross modulation.
2. Examine antenna and ground for poor connections.
3. Try capacity filter across light lines.
4. Look for and eliminate rectifying contacts in piping or wiring.
5. Find antenna location free from cross modulation and install antenna there with shielded lead-in to set.

By following this procedure it should be possible to clear up even stubborn cases of interference due to external cross modulation.

The discovery of the source of the external cross modulation phenomenon has led to proper analysis and elimination of many cases of interference which formerly were mysterious in origin and therefore difficult or impossible to remedy. The basic facts of the external cross modulation theory have been corroborated by laboratory and field observations, but the technique of elimination of the resultant interference has not yet reached a stage where complete freedom from interference can be secured in every case. This technique will undoubtedly improve as more experience is gained and as the basic causes become more widely known among service men. It is the service men who will in general be called upon to eliminate cases of external cross modulation since neither the transmitter nor the receiver designer can control this type of interference. Some benefit may be secured in the future by broadcast station allocation such that two high-powered stations are not located too close together geographically. Frequency and geographical allocation to prevent external cross modulation interfer-

¹ "Reduction of Distortion and Cross-Talk in Radio Receivers by Means of Variable-Mu Tetrodes." Stuart Ballantine and H. A. Snow. Proceedings of the Institute of Radio Engineers, December, 1930.

ence is difficult, however, because of the complexity of the broadcast allocation structure, and because allocation from the standpoint of external cross modulation alone may cause other types of interference to be aggravated.

The Crosley Radio Corporation has investigated external cross modulation extensively and presented a report to the F. C. C. at the January 18th, 1937 Engineering Conference at Washington, describing and analyzing their results in eliminating external cross modulation in nearly one thousand receiver installations.

Theoretical Discussion

A rectifier or non-linear element has a characteristic which may be expressed by a power series expansion:

$$\frac{i}{k} = m_0 + m_1e + m_2e^2 + m_3e^3 + \dots \tag{1}$$

where

i is output current of rectifier

k is rectification constant

e is applied voltage

*m*₀, *m*₁, etc. are coefficients of the rectification characteristic.

$$e = E_1 \cos a + E_2 \cos b \tag{2}$$

where

*E*₁ is amplitude of signal with frequency *a*.

*E*₂ is amplitude of signal with frequency *b*.

*E*₁ and *E*₂ vary at modulation frequency if signals are modulated.

Substituting (2) in (1) the resultant output of the rectifier becomes:

$$\begin{aligned} \frac{i}{k} = & m_0 + m_1E_1 \cos a \\ & + m_1E_2 \cos b + \frac{m_2}{2} E_1^2 \\ & + \frac{m_2}{2} E_1^2 \cos 2a + \frac{m_2}{2} E_2^2 \\ & + \frac{m_2}{2} E_2^2 \cos 2b \\ & + m_2E_1E_2 \cos (a + b) \\ & + m_2E_1E_2 \cos (a - b) \\ & + \frac{3m_3}{4} E_1^3 \cos a \end{aligned}$$

$$\begin{aligned} & + \frac{m_3}{4} E_1^3 \cos 3a + \frac{3m_3}{4} E_2^3 \cos b \\ & + \frac{m_3}{4} E_2^3 \cos 3b + \frac{3m_3}{2} E_1E_2^2 \cos a \\ & + \frac{3m_3}{4} E_1E_2^2 \cos (2b + a) \\ & + \frac{3m_3}{4} E_1E_2^2 \cos (2b - a) \\ & + \frac{3m_3}{2} E_1^2E_2 \cos b \\ & + \frac{3m_3}{4} E_1^2E_2 \cos (2a + b) \\ & + \frac{3m_3}{4} E_1^2E_2 \cos (2a - b). \end{aligned} \tag{3}$$

From this expression may be seen the large number of resultant frequencies and their relative magnitudes. The second order term results in new frequencies carrying the modulation of one or both of the signals. The third order term shows that rectification increases the modulation depth of the signal and also that the modulation of one signal becomes impressed on the frequency of the other signal. The third order term produces additional new frequencies carrying the modulation of one or both of the signals.

The Luxembourg Effect

About three years ago an effect was noticed in Europe whereby the modulation of the Luxembourg station, which is a high-powered long-wave station, was noticed in Holland on the frequencies of stations in the broadcast band, and caused interference with those stations.² This phenomenon was called the "Luxembourg effect" and was ascribed to a possible non-linearity of the transmission medium. Later this phenomenon of interference from the Luxembourg station was noticed in several other European countries. It is entirely possible that the effect was due to some non-linear element in the neighborhood of the receiving location and was therefore what we have called external cross modulation, especially since the Luxembourg effect is the first phenomenon which would

indicate the possibility of a non-linear medium of propagation. Examples have been found in this country of external cross modulation at distances from the interfering station of over 100 miles, which are similar to the observations of Luxembourg effect. In general, when the interfering station is at such a distance, it has been found that the interfering station has high power and that there are high-tension lines extending in the direction where the interference was found, so that field intensity of the interfering signal was high at those points.

²"Interaction of Radio Waves" by Balh. van der Pol and J. van der Mark. Publications of N. V. Philips Gloeilampenfabrieken, Nos. 964 and 1036.

A. G. Butt, "Radio World," April 28th, 1933. B. D. H. Tellegen, "Nature," June 10th, 1933. "Hochfrequenz Technik und Electro Akustik," 48:181-186, 1935.

"Onde Electricque" 14, No. 188, 80-808, 1935. "Wireless World," February 26th, 1937.

COVER DESIGN

The cover design by John Vassos is evidence direct of the extent to which RCA styling is carried.

Conceived as a home for twin 5-KW Transmitters, it retains in every detail this thought of its function as an integral part of the project. The basic structural forms and their relationship to the equipment are constantly held in view.

The many adjuncts of the installation such as air conditioning, lighting, shop, emergency quarters, etc., are also considered adequately as a vital part of the problem.

For the broadcaster there is the assurance that, in its meticulous study of every problem connected with the industry, RCA is striving to serve beyond mere equipment needs.

H. C. VANCE NOW LOCATED IN CAMDEN

H. C. Vance, formerly in charge of Broadcast Equipment activities in the Chicago territory, has been transferred to the Camden office. In his new position Mr. Vance will direct Communication Equipment and State Police sales.

Succeeding Mr. Vance in the Central District is A. R. Hopkins, who previously had charge of speech input sales in the Camden office.

A REVIEW OF BROADCAST ENGINEERING

Articles in Leading Publications, January-June, 1937

Reviewed by
J. P. TAYLOR

ACOUSTICS

Radio Studio Acoustics, by M. Rettinger, *Comm. & Broadcast Eng.*, Jan. 1937, Pg. 5.
Reverberation-Time Calculations, by A. J. Ebel, *Comm. & Broadcast Eng.*, Feb. 1937, Pg. 10.

Two notes on design methods for obtaining proper reverberatory characteristics in broadcast studios.

Reverberation and Absorption of Sound, by E. Meyer, *The Journal of the Acoustical Society of America*, Jan. 1937, Pg. 155.

Some measurements of sound absorption and decay curves in rooms of large and small size.

Acoustics and Ventilation, *Scientific American*, Feb. 1937, Pg. 136.

A new system of air distribution comprising a perforated sub-ceiling above which is placed the sound absorbing material.

A Scale for the Measurement of the Psychological Magnitude Pitch, by S. S. Stevens, J. Volkmann, and E. B. Newman, *The Journal of the Acoustical Society of America*, Jan. 1937, Pg. 185.

How Pitch Changes with Loudness, by A. R. Soffel, *Bell Labs. Record*, Jan. 1937, Pg. 145.

Two interesting discussions which emphasize the not-always-recognized difference between pitch and frequency. Quantitative measurements showing change of pitch with intensity.

How Loud is Sound? *Radio*, Jan. 1937, Pg. 92.

Reprint of article from *Brush Strokes*. See previous review.

ALLOCATION

Four New Stations Authorized by FCC, *Broadcasting*, Jan. 15, 1937, Pg. 16.
January authorizations.

Preliminary Engineering Report on Allocations, by T. A. M. Craven and A. D. Ring, *Broadcasting*, Supplement, Jan. 15, 1937.

Full text of the preliminary report of January 14th, based on the October 1936 hearings.

FCC Plan Paves Way for 500 New Stations, by S. Taishoff, *Broadcasting*, Jan. 15, 1937, Pg. 9.

Discussion of above.

Revised Basis of Signal Ratio Urged at Session of Engineers and Lawyers, *Broadcasting*, Feb. 1, 1937, Pg. 58.

Report of the informal discussion on January 18th, 1937.

Hearing by FCC Is Foreseen on Duplicated Clear Channels, *Broadcasting*, Feb. 15, Pg. 40.

Report of possibility of hearing on duplicated channels being held before new allocation rulings.

North American Radio Conference Called, by S. Taishoff, *Broadcasting*, March 1, 1937, Pg. 11.

Cleanup of North American Band Sought, *Broadcasting*, March 15, 1937, Pg. 18.

Preliminary to March conference in Havana.

APEX

FCC Reopens High Frequency Band, *Broadcasting*, March 15, 1937, Pg. 24.

Report on granting of three new Apex authorizations—also amplified rules regarding Apex operation.

U. H. F. Concentric Line Feeders, by E. H. Conklin, *Radio*, Feb. 1937, Pg. 24.

Methods of matching low impedance lines to end-fed antennas.

MICROPHONES

The "Salt-Shaker," A New Microphone, *Pickups*, Feb. 1937, Pg. 8

Full information on a new inexpensive diaphragm-type microphone for broadcast and other uses.

New "Mike" Is Uni-directional, by S. Kaufman, *Radio News*, Jan. 1937, Pg. 407.

Uni-Directional Microphones, by T. A. Smith, *Under Control*, Jan. 1937, Pg. 10.

Short write-ups on the Type 77-A Uni-directional Microphone.

Some Fundamental Characteristics of Rochelle Salt, by C. H. Tower, *Brush Strokes*, Jan. 1937, Pg. 3.

Some Fundamental Characteristics of Rochelle Salt, Part II, by C. H. Tower, *Brush Strokes*, Feb. 1937, Pg. 4.

A short resume of the characteristics of crystals suitable for sound pickup.

MEASUREMENT

The Primary Radio Frequency Standard, by R. P. Turner, *Radio*, Jan. 1937, Pg. 150.

A short description of the primary frequency standard of the Bureau of Standards, Washington, D. C.

The Distortion Factor of a Complex Wave, by H. Roder, *Radio Engineering*, Feb. 1937, Pg. 10.

Another method of graphically measuring harmonic content—chiefly valuable where harmonic distortion is high.

The Measurement of Interelectrode Capacities, by P. A. Ekstrand, *Radio Engineering*, Feb. 1937, Pg. 15.

A simple substitution method for the measurement of tube capacities.

Automatic Recording of Audio-Frequency Characteristics, *Radio Engineering*, Feb. 1937, Pg. 20.

Brief note on the operation of the Audi-O-Graph.

A D-C Amplifier for logarithmic Recording, by J. P. Taylor, *Electronics*, March 1937, Pg. 24.

An amplifier useful in making logarithmic recordings of field intensity, and the like,—where the measuring device has a linear output.

Portable Reverberation Meter, by H. J. Sabine, *Electronics*, March 1937, Pg. 30.

Description of equipment for measuring the decay period in studios, auditoriums, etc.

MODULATION

Relation Between Antenna Current and Modulation, *Comm. & Broadcast Eng.*, Jan. 1937, Pg. 17.

Graph of antenna circuit increase versus percent modulation.

OPERATION

The Election Day Broadcast, by L. Farkas, *Under Control*, Jan. 1937, Pg. 12.

On to Washington, *Under Control*, Jan. 1937, Pg. 9.

Seven Days on the Mississippi, by S. M. Bergere, *Under Control*, March 1937, Pg. 3.

On the election day, inauguration, and flood emergency pickups of CBS.

Behind the Scenes at Two Notable Broadcasts, by G. McElrath and G. O. Milne, *RCA Review*, Jan. 1937, Pg. 94.

On the special event programs of NBC's tenth anniversary celebration.

The Engineering Activities and Problems of a Radio Broadcasting System, by H. A. Chinn, *Under Control*, Jan. 1937, Pg. 3.

Organization, operation and responsibility of a network engineering department—by the engineer-in-charge, Audio Division, Columbia Broadcasting System.

Broadcast Station Statistics, *Electronics*, Jan. 1937, Pg. 24.

Average investment and maintenance costs of broadcast stations,—from statistical survey of the United States Department of Commerce and the National Advisory Council on Radio and Education.

Interesting Information About "Spot" Broadcasting, by R. D. Washburne, *Radio Craft*, Feb. 1937, Pg. 456.

Resume of some recent spot broadcasts.
The BBC Program Transmission System, by D. Hallam, Jr., *Comm. & Broadcast Eng.*, Feb. 1937, Pg. 12.

Brief description of the distribution system of the British Broadcasting Company—with map showing location and facilities of stations.

POLICE

Boston Police Department's Communications System, *Comm. & Broadcast Eng.*, Feb. 1937, Pg. 15.

Short resume of Boston Police radio facilities.

PROPAGATION

Some Notes on Ultra High Frequency Propagation, by H. H. Beverage, *RCA Review*, Jan. 1937, Pg. 76.

A general review of ultra-high-frequency propagation studies to-date—including results of some recent work.

Radio Propagation Over Plane Earth—Field Strength Curves, by C. R. Burrows, *The Bell Tech. Journal*, Jan. 1937, Pg. 45.

Curves for calculation of propagation over plane earth—with relations for the calculation of effect of antenna height.

RECORDING

An Instantaneous Recording Head, by G. J. Saliba, *Comm. & Broadcast Eng.*, March 1937, Pg. 8.

Discussion of a new recording head. (Presto).

SPEECH INPUT

Modern Speech Input Equipment, *Pickups*, Feb. 1937, Pg. 14.

Short description of the Type 22-A Remote Equipment and Type 23-A Console Equipment.

Balanced Amplifiers, Part VII, by A. Preisman, *Comm. & Broadcast Eng.*, Jan. 1937, Pg. 8.

Continuation (see previous review).

The Acorn Tube on the Remote Job, by W. E. Stewart, *Comm. & Broadcast Eng.*, Feb. 1937, Pg. 9.

Short description of a remote equipment using acorn type tubes.

Feedback Amplifier Design, by F. E. Terman, *Electronics*, Jan. 1937, Pg. 12.

A good general treatment of the use of feedback in audio amplifiers,—with a description of several types of circuits.

Some Practical Inverse Feedback Circuits for Audio Power Amplifier, QST, Jan. 1937, Pg. 26.

More on feedback amplifiers—with data on several practical designs.

Regulating Electrolytic Condensers, by P. M. Deeley, Service, March 1937, Pg. 141.

Theory and use of electrolytic condensers of the type giving a certain amount of voltage regulation.

Two-Terminal Equalizers, by C. S. Smith, Comm. & Broadcast Eng., March 1937, Pg. 10.

Information on, and methods for, the design of networks for equalizing attenuation of telephone transmission lines.

Calculations for Class A Amplifiers, by E. K. Brown, Radio Engineering, Jan. 1937, Pg. 9.

Calculation of operating conditions for maximum power output.

TELEVISION

Philco Shows 441-Line Television, Electronics, March 1937, Pg. 9.

441-Line Television, Radio Engineering, Feb. 1937, Pg. 5.

Philco Exhibits Improve Television in Adopting RMA 441-Line Standard, by B. Robertson, Feb. 15, 1937, Pg. 16.

Short notes on the favorable demonstration of the 44-Line Television (Philco).

RCA Describes Television System, Electronics, Jan. 1937, Pg. 8.

Equipment Used in the Current RCA Television Field Tests, by R. R. Beal, RCA Review, Jan. 1937, Pg. 36.

Two fairly lengthy descriptions of the equipment and set-up for the RCA television field tests (as demonstrated during November).

NBC-RCA Television "On The Air," Radio Craft, Feb. 1937, Pg. 465.

A short resume of the same.

Partial Suppression of One Side Band in Television Reception, by W. J. Poch and D. W. Epstein, IRE Proc., Jan. 1937, Pg. 15.

Results of an experimental study of the advisability of operating a television system with the carrier at one edge of the selectivity curve.

Partial Suppression of one Side Band in Television Reception, by J. W. Poch and D. W. Epstein, RCA Review, Jan. 1937, Pg. 19.

Reprint of the above.

Frequency Assignments for Television, by E. W. Engstrom and C. M. Burrill, RCA Review, Jan. 1937, Pg. 88.

A review and description of the pertinent subject.

Close-Mike vs. Reverberatory Monitoring, by C. Felstead, Comm. & Broadcast Eng., Jan. 1937, Pg. 12.

Methods of sound pickup in motion picture work,—assumably of interest in development of television studio technique.

Note: Because of the large number of popular articles on television now appearing,—and the limited space available,—this review will hence-forward include only those developments deemed of outstanding importance.

TRANSMITTER DESIGN

Stabilized Feedback for Radio Transmitters, by L. G. Young, Bell Lab. Record, Feb. 1937, Pg. 182.

A brief, but unusually understandable description of the value and use of feedback in broadcast transmitters.

Measurements of the Plate Resistance of High-Frequency Class B & C Amplifiers, by Dr. V. A. Babits, Comm. & Broadcast Eng., Jan. 1937, Pg. 7.

Graphical determination of operating conditions of r-f amplifiers.

About R. F. Voltage and Current Ratings of Mica Transmitting Condensers, QST, Jan. 1937, Pg. 43.

Extracts from Aerovox Research Worker of October 1936.

The Cause, Effects, and Cure of Parasitics, by E. Hayes, and K. V. Keeley, Radio, Jan. 1937, Pg. 42.

Chiefly pertaining to amateur transmitters, but can be read with interest.

Electrostatic Shields in Transmitter Output Circuits, QST, March 1937, Pg. 19.

Amateur application of a feature now well-accepted practice in broadcast design.

TUBES

A Half-Meter Tube, by C. E. Fay, Bell Labs. Record, Feb. 1937, Pg. 178.

4 Watts at 600 MC.—The 316A, by C. E. Fay, Pickups, Feb. 1937, Pg. 6.

Similar notes on the new Type 316A Tube for frequencies up to 600 megacycles. **Characteristics of Transmitting Tubes**, by J. G. Sperling, Comm. & Broadcast Eng., Feb. 1937, Pg. 18.

An interesting chart of tube characteristics which shows the relation of different types almost at a glance.

F. C. C. Power Ratings of Common Tubes, Radio, Jan. 1937, Pg. 46.

Approved FCC ratings of tubes for use in the final stage of broadcast transmitters. **A New and Complete Tube Table**, Radio, Jan. 1937, Pg. 140.

A table of low-power transmitting tubes with operating voltages, amplification factor, etc.

Gridless vs. Grid Tubes, Part II, by H. F. Dalpayrat, Radio Craft, Jan. 1937, Pg. 396.

Continuation (see previous review).

Simplified Methods for Computing Performance of Transmitting Tubes, by W. G. Wagener, IRE Proc., Jan. 1937, Pg. 47.

Methods for approximating performance, described and illustrated.

Movable Anode Tubes, by E. D. McArthur, Electronics, March 1937, Pg. 16.

Interesting new development of a tube type in which plate current control is effected by changing the position of the anode.

Testing Transmitting Tubes, Radio, March 1937, Pg. 48.

Note on test and reactivation of transmitting tubes.

MISCELLANEOUS

My First Transatlantic Wireless Signal, by G. Marconi, Radio-Craft, Mar. 1937, Pg. 520.

The time-hallowed story.

Another Inventor of Radio, Broadcasting, Jan. 1937, Pg. 32.

Claims on behalf of Nathan B. Stubblefield.

Factors Relating to Faithful Reproduction, by C. M. Sinnett, Proc. of the Radio Club of America, March 1937, Pg. 3.

A description of a number of interesting factors pertaining to phonograph and radio reception.

Wide-Band Open-Wire Program System, by H. S. Hamilton, Under Control, March 1937, Pg. 7.

Interesting description of the frequency and attenuation characteristics of high quality transmission facilities.

ACOUSTICS

Sound Analysis, by H. H. Hall, Jour. A. S. A., April 1937, Pg. 257.

A resume of instruments available for sound analysis, with a brief description of the operation of each type.

Loudness Measurements, by W. A. Munson, Bell Labs. Record, June 1937, Pg. 306.

Relation of loudness to intensity; comparison of practice and theory.

ADVANCE DEVELOPMENT

Air-Wave Bending of Ultra-High-Frequency Waves, Part I, by R. A. Hull, QST, May 1937, Pg. 16.

Outline of observations of ultra-high-frequency transmission over a hundred-mile path.

ALLOCATION

Nations Agree on Continental Allocation, Broadcasting, April 1, 1937, Pg. 17.

Summary of Results of the Havana Radio Conference, Broadcasting, April 1, 1937, Pg. 62.

Allocation Principles Adopted at Havana Radio Conference, Broadcasting, April 15, 1937, Pg. 21.

North American Channel Shifts Seen, Broadcasting, April 15, 1937, Pg. 20.

Summary of the results of the North American radio conference held in Havana, March 15-29, 1937; discussion of agreements reached with relation to frequency allocations in this country.

New FCC Rural Coverage Survey Started, Broadcasting, April 1, 1937, Pg. 25.

Information on FCC's letter to rural postmasters asking information on local reception conditions.

Two New Locals; Full-Time Granted WKZO on 590 KC, Broadcasting, May 1, 1937, Pg. 24.

New stations. **Full Time for Clear Stations by Duplicate Operation Asked**, Broadcasting, May 1, 1937, Pg. 22.

More on the duplicate clear-channel operation business.

ANTENNAS

The Shunt-Excited Antenna, by J. F. Morrison and P. H. Smith, IRE Proc., June 1937, Pg. 673.

The original paper (presented before the Cleveland Convention) describing an arrangement for exciting a vertical broadcast antenna with the base grounded. Experimental installations are described together with the results obtained.

Notes on Broadcast Antenna Developments, by R. A. Guy, RCA Review, April 1937, Pg. 39.

A general discussion of the subject, particularly as related to antenna effectiveness; a resume of the results of a study on distant transmission with relation to the vertical distribution pattern; and a note on the effect of current distribution on fading. Also some data on the new WJZ antenna.

The Fading Characteristics of the Top-Loaded WCAU Antenna, by G. H. Brown and J. G. Leitch, IRE Proc., May 1937, Pg. 583.

An unusually interesting paper describing the measured results of the practical application of top-loading to the problem of fading reduction.

Directional Antennas, by G. H. Brown, Broadcast News, May 1937, Pg. 12.

Reprinted from IRE Proceedings. See previous review.

Ground Systems as a Factor in Antenna Efficiency, by G. H. Brown, R. F. Lewis, and J. Epstein, IRE Proc., June 1937, Pg. 753.

Theoretical considerations and experimental data on the effect of the type and size of ground system used. Results indicate, among other things, that an eighth-wave antenna is practically as efficient as a quarter-wave antenna, providing the ground system is sufficient.

Some Typical Broadcast Antenna Installations, Comm. & Broadcast Eng., April 1937, Pg. 24.

Photos of a number of broadcast antennas.

MICROPHONES

New Directional Mike has "Infinite Baffle," by S. Minsker, Radio Craft, May 1937, Pg. 654.

On the Uni-directional microphone.

FIELD INTENSITY

Skip-Distance Calculation, by N. Smith, QST, May 1937, Pg. 47.

A chart for rapid graphical determination of the "angle of incidence."

Ground-Wave Attenuation at Broadcast Frequencies, by C. D. Perkins, Comm. & Broadcast Eng., May 1937, Pg. 16.

Discussion of the factors influencing ground wave attenuation—with some measured characteristics taken in the state of Oregon.

Logarithmic Recording of Field Intensities, by J. P. Taylor, Broadcast News, May 1937, Pg. 6.

Description of an equipment for making field intensity recordings on a logarithmic scale.

Characteristics of Amplitude Modulated Waves, by E. A. Laport, RCA Review, April 1937, Pg. 26.

A general discussion based on the treatment using vector relations—particularly good as regards combined phase and amplitude modulation.

MEASUREMENT

Equipment and Methods Used in Routine Measurements of Loudspeaker Response. Part II, by S. V. Perry, Radio Engineering, April 1937, Pg. 16.

Equipment and Methods Used in Routine Measurements of Loudspeaker Response. Part III, by S. V. Perry, Radio Engineering, May 1937, Pg. 22.

Second and third part of a comprehensive resume of current practice in loudspeaker measurements. See previous review.

Zero-Current Voltmeter, by B. Thompson, Service, June 1937, Pg. 370.

Description of a zero current voltmeter for measurement of voltages in AVC circuits and the like.

A New Noise Meter, by J. M. Barstow, Bell Labs Record, April 1937, Pg. 252.

Brief description of a new noise-measuring set. Includes curves showing "weighting" for program circuit, etc.

Distortion Measurements in the Broadcast Station, The General Radio Exp., April 1937, Pg. 1.

Brief note with particular reference to type 732-A Meter.

An Improved Output Meter, by W. G. Webster, The General Radio Exp., June 1937, Pg. 5.

Brief description of a new output meter for general rather than broadcast use. Includes information on characteristics, etc.

OPERATION

WWV Transmission, All-Wave Radio, June 1937, Pg. 284.

WWV Services Again Expanded, QST, June 1937, Pg. 10.

Intermission on the added WWV schedules.

Real Drama on the Air, by H. Stone, Broadcast News, May 1937, Pg. 15.

W.S.M.'s part in the Ohio flood **Broadcast Relay Transmitter**, Comm. & Broadcast Eng., May 1937, Pg. 20.

Description of WOR-built portable relay transmitter. Includes schematic diagram.

RECORDING

Direct Recording and Reproducing Materials for Disk Recording, by A. C. Keller, Jour. A. S. E., April 1937, Pg. 234.

Some information on the characteristics of the various materials available for direct recording and reproducing work.

SPEECH INPUT

Program Amplifier Increases Signal 3 db, Reduces Work of Monitoring Operator, by O. M. Hovgaard, Pickups, June 1937, Pg. 3.

Description of the type 110-A Amplifier which includes program limiting circuits for which various advantages are claimed. **Universal Amplification Charts**, by F. E. Terman, Electronics, June 1937, Pg. 34.

Charts for determination of the gain-frequency characteristics of conventional amplifiers in terms of their component parts.

New Equipment Solves Problem for Smaller Stations, by W. L. Lyndon, Broadcast News, May 1937, Pg. 10.

Description and schematic of a simplified factory-assembled speech input equipment. **Mixer Circuits, Part I**, by A. Preisman, Comm. & Broadcast Eng., June 1937, Pg. 9.

First part of a comprehensive analysis of mixer circuits of various types.

Characteristics of Inverse-Feedback Circuits, by L. Martin, Radio Engineering, May 1937, Pg. 13.

Practical Feedback Amplifiers, by J. R. Day and J. B. Russell, Electronics, April 1937, Pg. 16.

Audio Feedback, by A. R. Remble, Comm. & Broadcast Eng., April 1937, Pg. 14.

More information on the application of inverse feedback for the reduction of distortion and noise level in audio amplifiers.

TELEVISION

Television Studio Considerations, Part I, by W. C. Eddy, Comm. & Broadcast Eng., April 1937, Pg. 12.

Television Studio Considerations, Part II, by W. C. Eddy, Comm. & Broadcast Eng., May 1937, Pg. 14.

Television Studio Considerations, Part III, by W. C. Eddy, Comm. & Broadcast Eng., June 1937, Pg. 20.

An extended resume of problems of television studio technique by the studio director of Farnsworth Television Incorporated.

Farnsworth Television, Radio News, May 1937, Pg. 654.

A short description with a number of illustrations of the Farnsworth 441-line installation.

IRE Sees Projection Television, Electronics, June 1937, Pg. 7.

A short note on the RCA demonstration of television to engineers at the IRE Convention.

Television Terminology, Electronics, June 1937, Pg. 14.

A very timely article explaining some of the new terms which are glibly used by television workers, but are still for the most part meaningless to the average engineer.

Experimental Studio Facilities for Television, by O. E. Hanson, RCA Review, April 1937, Pg. 3.

A resume of the RCA television field tests with a detailed discussion of some of the problems of television studio design. Illustrations and a diagram of the studio layout.

Television in Great Britain, by N. A. Ashbridge, IRE Proc., June 1937, Pg. 697.

A short review of the development and status of television in Great Britain including a brief review of the operating characteristics of the Baird and Marconi E. M. I. Systems.

TRANSMITTER DESIGN

Table of Approved Tubes for Operation in the Last Radio Stage of Broadcast Transmitters, Comm. & Broadcast Eng., April 1937, Pg. 11.

A complete list of the tubes which may be used in the final stage of broadcast transmitters with ratings and characteristics.

Stabilized Feedback for Radio Transmitters, by L. G. Young, Radio, April 1937, Pg. 58.

Reprint from Bell Labs Record. See previous review.

Multi-Wire Lines and Matching Sections, by C. J. Madsen, Radio, April 1937, Pg. 66.

A chart for determining the surge impedance of open-wire lines employing from two to ten wires.

Features Bring New Transmitter to the Front, by C. M. Lewis, Broadcast News, May 1937, Pg. 20.

Description of a modulator unit for converting the RCA Type 100-E Transmitter for operation at 250 watts.

The Low-Power Transmitters, by J. P. Taylor, Comm. & Broadcast Eng., June 1937, Pg. 14.

First part of a general review of the characteristic and features of the "standard" transmitters for low-power (100/250 watts) broadcast stations. Illustrations and schematics.

Buildings for Medium Powered Transmitters, by T. A. Smith, Broadcast News, May 1937, Pg. 28.

Some general considerations and suggestions on the design of buildings for medium-powered broadcast installations.

Plate Modulation: A Recapitulation, by F. A. Everest, Radio, May 1937, Pg. 46.

Modernized version of the conventional diagram and illustration of plate modulation.

Grid Control of Radio Rectifiers, by S. R. Durand and O. Keller, IRE Proc., May 1937, Pg. 570.

A discussion of the use of grid control devices in mercury arc-type rectifiers—with a resume of the advantages.

Unique Features at Seattle, by F. J. Brott, Broadcast News, May 1937, Pg. 26.

Hearst Expands Coast Stations, by F. Ragsdale, Broadcast News, May 1937, Pg. 4.

Twin Buffalo Stations Modernize, by R. J. Kingsley, Broadcast News, May 1937, Pg. 18.

Short notes on recent transmitter installations of more than usual interest.

TUBES

The RCA-887, 888, Comm. & Broadcast Eng., June 1937, Pg. 18.

Description and characteristics of the new water-cooled ultra-high frequency tubes.

Frank Talk About This Business of Transmitting Tube Ratings, by E. C. Hughes, Jr., QST, June 1937, Pg. 28.

The low-down on tube testing, tube rating and tube operating—by the man who should know.

MISCELLANEOUS

Characteristics of American Broadcast Receivers as Related to the Power and Frequency of Transmitters, by A. VanDyck and D. E. Foster, IRE Proc., April 1937, Pg. 387.

An authoritative discussion of the relation of receiver characteristics to the problem of allocation and power of transmitters. An important approach to the question of increased transmitter powers and other allocation problems.

A New Form of Interference—External Cross Modulation, by D. E. Foster, RCA Review, April 1937, Pg. 18.

Discussion of broadcast reception interference caused by rectification of radio frequencies in the lighting wires or other metallic conductors near the receiving antennas.

Slide-Rule Impedance Calculations, Electronics, May 1937, Pg. 45.

Method of obtaining the sum of two impedances, the reactance-resistance ratio, and phase angle, by slide rule methods.

Decibel Table, Radio, May 1937, Pg. 39.

Voltage-current-impedance relations at various line impedances.

Notes About Our Contributors

DR. G. H. BROWN—Notes on Dr. Brown have appeared in Broadcast News from time to time in connection with his outstanding articles on antennas.

JOHN M. BRUMBAUGH—Mr. Brumbaugh was born at Hesston, Pa., in 1906. He received the M.S. in E.E. degree from the Moore School of Electrical Engineering at the University of Pennsylvania in 1932. After serving for three years as a member of the Physics Staff at the Franklin Institute in Philadelphia, he came to the Engineering Department of the RCA Manufacturing Company, in August, 1935.

G. H. CLARK—Graduate of Massachusetts Institute of Technology, 1903, first student to take radio engineering as a specialty; with Stone Telegraph and Telephone Co., pioneer wireless concern of Boston, Mass., under Professor John Stone Stone, to 1908; appointed sub-inspector of wireless telegraph stations with U. S. Navy for duty with Navy Department, Washington, 1908; transferred to expert radio aid, Navy Department, 1915; resigned from Government service, 1919, to come with Marconi Wireless Telegraph Co. of America; duty with R. A. Weagant in static reduction for one year; then in charge of RCA's show division, for national shows and expositions, for ten years; now with Department of Information, RCA. Charter member, Society of Wireless Telegraph Engineers; Charter member, Institute of Radio Engineers; past president, Veteran Wireless Operators' Association; executive secretary of VWOA Committee on monument to the late Guglielmo Marconi. Assistant Editor, RCA Family Circle.

DUDLEY E. FOSTER—Received his E.E. degree at Cornell University in 1922. Prior to attending college he served during the war as commercial radio operator for the Marconi Company. Following his graduation from Cornell he became associated as electrical engineer with the Electrical Alloy Company and Driver-Harris Company. In 1925 he joined the Malcne-Lemmon Products Company as Production Engineer and the next year became Chief Engineer of the Case Electric Company. Two years later he became Assistant Chief Engineer of the United States Radio and Television Corporation and soon after was promoted to Chief

Engineer. In 1933, as the result of another merger, that organization became the General Household Utilities Company, of which he became Chief Radio Engineer. In 1934 Mr. Foster took up his present duties as engineer in the RCA License Laboratory. He is a member of the Institute of Radio Engineers.

KARL B. HOFFMAN—Mr. Hoffman, who tells of the new developments at WGR-WKBW, is the Technical Director of the Buffalo Broadcasting Corporation.

C. M. LEWIS—A biographical note concerning Mr. Lewis appeared in the May issue of Broadcast News.

BEN W. ROBINS—Born at Hattiesburg, Miss., 1908. Wireless operator on board ship during two summer vacations from college. Graduated from Mississippi State College in 1928. Joined G. E. Company in Schenectady in 1928 and RCA Engineering Department in 1930.

J. L. TALLEY—Mr. Talley who contributes the story on WRDW has, in addition to his knowledge in the radio field, wide experience in the field of education.

JOHN VASSOS—Biographical notes have appeared in several previous issues of Broadcast News. In addition to his work in designing RCA products, Mr. Vassos is consultant for many firms, including Remington-DuPont.

M. R. WILLIAMS—Mr. Williams has been the chief engineer at WFBM for a number of years. Prior to being connected with this station he had been engaged in other phases of radio.

J. E. YOUNG—Born in West Chester, Penna., in 1906. Graduated from Drexel Institute in 1928, with a B.S. in E.E. After graduating from Drexel he joined the Radio Engineering Department of the General Electric Company to work on the then super power 50 KW broadcast transmitter under development at South Schenectady. Later he worked on short wave broadcast transmitters and investigation of adjacent channel interference. On June 1, 1932, transferred to the Engineering Department of RCA Victor Co., and has since been engaged in designing transmitters for broadcast and government services.



Frequency Measuring Service



STABILITY

RCA Frequency Measuring Service assures you of unchanging dependability based on foundations as solid and unyielding as the mountains themselves. When your frequency must be checked, use RCA's fundamental standards and wire or 'phone to the laboratory. Don't take chances on being off frequency.

For Routine Service Apply at the Nearer Office

Commercial Department
New York, N. Y.
66 Broad Street
Phone: HAnover 2-1811

Commercial Department
San Francisco, Calif.
28 Geary Street
Phone: Garfield 4200

For Emergency Service Phone or Wire the Nearer Laboratory
(Open Day and Night)

Riverhead, N. Y.
Phone: Riverhead 2290
W. U. Telegraph Only
Riverhead, New York

Point Reyes, Calif.
Phone: Inverness 9-W
W. U. Telegraph Only
Point Reyes Station
Marin Co., Calif.

R.C.A. COMMUNICATIONS, Inc.

A RADIO CORPORATION OF AMERICA SERVICE



Frequency Measuring Service



STABILITY

RCA Frequency Measuring Service assures you of unchanging dependability based on foundations as solid and unyielding as the mountains themselves. When your frequency must be checked, use RCA's fundamental standards and wire or 'phone to the laboratory. Don't take chances on being off frequency.

For Routine Service Apply at the Nearer Office

Commercial Department
New York, N. Y.
66 Broad Street
Phone: HAnover 2-1811

Commercial Department
San Francisco, Calif.
28 Geary Street
Phone: Garfield 4200

For Emergency Service Phone or Wire the Nearer Laboratory
(Open Day and Night)

Riverhead, N. Y.
Phone: Riverhead 2290
W. U. Telegraph Only
Riverhead, New York

Point Reyes, Calif.
Phone: Inverness 9-W
W. U. Telegraph Only
Point Reyes Station
Marin Co., Calif.

R.C.A. COMMUNICATIONS, Inc.

A RADIO CORPORATION OF AMERICA SERVICE